

Model 2701 Ethernet-Based DMM / Data Acquisition System

Service Manual

2701-902-01 Rev. B / December 2018



2701-902-01B

Model 2701

Ethernet-Based DMM / Data Acquisition System

Service Manual

© 2018, Keithley Instruments, LLC

Cleveland, Ohio, U.S.A.

All rights reserved.

Any unauthorized reproduction, photocopy, or use of the information herein, in whole or in part, without the prior written approval of Keithley Instruments, LLC, is strictly prohibited.

These are the original instructions in English.

All Keithley Instruments product names are trademarks or registered trademarks of Keithley Instruments, LLC. Other brand names are trademarks or registered trademarks of their respective holders.

Microsoft, Visual C++, Excel, and Windows are either registered trademarks or trademarks of Microsoft Corporation in the United States and/or other countries.

Document number: 2701-902-01 Rev. B / December 2018

The following safety precautions should be observed before using this product and any associated instrumentation. Although some instruments and accessories would normally be used with nonhazardous voltages, there are situations where hazardous conditions may be present.

This product is intended for use by personnel who recognize shock hazards and are familiar with the safety precautions required to avoid possible injury. Read and follow all installation, operation, and maintenance information carefully before using the product. Refer to the user documentation for complete product specifications.

If the product is used in a manner not specified, the protection provided by the product warranty may be impaired.

The types of product users are:

Responsible body is the individual or group responsible for the use and maintenance of equipment, for ensuring that the equipment is operated within its specifications and operating limits, and for ensuring that operators are adequately trained.

Operators use the product for its intended function. They must be trained in electrical safety procedures and proper use of the instrument. They must be protected from electric shock and contact with hazardous live circuits.

Maintenance personnel perform routine procedures on the product to keep it operating properly, for example, setting the line voltage or replacing consumable materials. Maintenance procedures are described in the user documentation. The procedures explicitly state if the operator may perform them. Otherwise, they should be performed only by service personnel.

Service personnel are trained to work on live circuits, perform safe installations, and repair products. Only properly trained service personnel may perform installation and service procedures.

Keithley products are designed for use with electrical signals that are measurement, control, and data I/O connections, with low transient overvoltages, and must not be directly connected to mains voltage or to voltage sources with high transient overvoltages. Measurement Category II (as referenced in IEC 60664) connections require protection for high transient overvoltages often associated with local AC mains connections. Certain Keithley measuring instruments may be connected to mains. These instruments will be marked as category II or higher.

Unless explicitly allowed in the specifications, operating manual, and instrument labels, do not connect any instrument to mains.

Exercise extreme caution when a shock hazard is present. Lethal voltage may be present on cable connector jacks or test fixtures. The American National Standards Institute (ANSI) states that a shock hazard exists when voltage levels greater than 30 V RMS, 42.4 V peak, or 60 VDC are present. A good safety practice is to expect that hazardous voltage is present in any unknown circuit before measuring.

Operators of this product must be protected from electric shock at all times. The responsible body must ensure that operators are prevented access and/or insulated from every connection point. In some cases, connections must be exposed to potential human contact. Product operators in these circumstances must be trained to protect themselves from the risk of electric shock. If the circuit is capable of operating at or above 1000 V, no conductive part of the circuit may be exposed.

Do not connect switching cards directly to unlimited power circuits. They are intended to be used with impedance-limited sources. NEVER connect switching cards directly to AC mains. When connecting sources to switching cards, install protective devices to limit fault current and voltage to the card.

Before operating an instrument, ensure that the line cord is connected to a properly-grounded power receptacle. Inspect the connecting cables, test leads, and jumpers for possible wear, cracks, or breaks before each use.

When installing equipment where access to the main power cord is restricted, such as rack mounting, a separate main input power disconnect device must be provided in close proximity to the equipment and within easy reach of the operator.

For maximum safety, do not touch the product, test cables, or any other instruments while power is applied to the circuit under test. ALWAYS remove power from the entire test system and discharge any capacitors before: connecting or disconnecting cables or jumpers, installing or removing switching cards, or making internal changes, such as installing or removing jumpers.

Do not touch any object that could provide a current path to the common side of the circuit under test or power line (earth) ground. Always make measurements with dry hands while standing on a dry, insulated surface capable of withstanding the voltage being measured.

For safety, instruments and accessories must be used in accordance with the operating instructions. If the instruments or accessories are used in a manner not specified in the operating instructions, the protection provided by the equipment may be impaired.

Do not exceed the maximum signal levels of the instruments and accessories. Maximum signal levels are defined in the specifications and operating information and shown on the instrument panels, test fixture panels, and switching cards.

When fuses are used in a product, replace with the same type and rating for continued protection against fire hazard.

Chassis connections must only be used as shield connections for measuring circuits, NOT as protective earth (safety ground) connections.

If you are using a test fixture, keep the lid closed while power is applied to the device under test. Safe operation requires the use of a lid interlock.

If a  screw is present, connect it to protective earth (safety ground) using the wire recommended in the user documentation.

The  symbol on an instrument means caution, risk of hazard. The user must refer to the operating instructions located in the user documentation in all cases where the symbol is marked on the instrument.

The  symbol on an instrument means warning, risk of electric shock. Use standard safety precautions to avoid personal contact with these voltages.

The  symbol on an instrument shows that the surface may be hot. Avoid personal contact to prevent burns.

The  symbol indicates a connection terminal to the equipment frame.

If this  symbol is on a product, it indicates that mercury is present in the display lamp. Please note that the lamp must be properly disposed of according to federal, state, and local laws.

The **WARNING** heading in the user documentation explains hazards that might result in personal injury or death. Always read the associated information very carefully before performing the indicated procedure.

The **CAUTION** heading in the user documentation explains hazards that could damage the instrument. Such damage may invalidate the warranty.

The **CAUTION** heading with the  symbol in the user documentation explains hazards that could result in moderate or minor injury or damage the instrument. Always read the associated information very carefully before performing the indicated procedure. Damage to the instrument may invalidate the warranty.

Instrumentation and accessories shall not be connected to humans.

Before performing any maintenance, disconnect the line cord and all test cables.

To maintain protection from electric shock and fire, replacement components in mains circuits — including the power transformer, test leads, and input jacks — must be purchased from Keithley. Standard fuses with applicable national safety approvals may be used if the rating and type are the same. The detachable mains power cord provided with the instrument may only be replaced with a similarly rated power cord. Other components that are not safety-related may be purchased from other suppliers as long as they are equivalent to the original component (note that selected parts should be purchased only through Keithley to maintain accuracy and functionality of the product). If you are unsure about the applicability of a replacement component, call a Keithley office for information.

Unless otherwise noted in product-specific literature, Keithley instruments are designed to operate indoors only, in the following environment: Altitude at or below 2,000 m (6,562 ft); temperature 0 °C to 50 °C (32 °F to 122 °F); and pollution degree 1 or 2.

To clean an instrument, use a cloth dampened with deionized water or mild, water-based cleaner. Clean the exterior of the instrument only. Do not apply cleaner directly to the instrument or allow liquids to enter or spill on the instrument. Products that consist of a circuit board with no case or chassis (e.g., a data acquisition board for installation into a computer) should never require cleaning if handled according to instructions. If the board becomes contaminated and operation is affected, the board should be returned to the factory for proper cleaning/servicing.

Safety precaution revision as of June 2017.

Table of contents

Performance verification	1-1
Introduction	1-1
Verification test requirements	1-2
Environmental conditions	1-2
Warm-up period	1-2
Line power.....	1-2
Recommended test equipment	1-3
Verification limits	1-3
Example reading limit calculation	1-4
Calculating resistance reading limits	1-4
Restoring factory defaults	1-4
Performing the verification test procedures	1-5
Verification test summary	1-5
Test considerations	1-6
Model 2701 verification	1-6
Verifying DC voltage	1-7
Verifying AC voltage.....	1-9
Verifying DC current.....	1-10
Verifying AC current.....	1-11
Verifying resistance.....	1-12
Verifying temperature.....	1-14
Verifying frequency	1-16
Model 7700 verification	1-16
Verifying DC voltage	1-17
Verifying AC voltage.....	1-19
Verifying DC current.....	1-20
Verifying AC current.....	1-21
Verifying resistance.....	1-22
Verifying temperature.....	1-24
Verifying frequency	1-27
Verifying ratio and average	1-28
Calibration	2-1
Introduction	2-1
Environmental conditions	2-1
Warm-up period	2-2
Line power.....	2-2
Calibration considerations.....	2-3
Calibration code	2-3
Front panel calibration code.....	2-4
Remote calibration code	2-4
Comprehensive calibration	2-4
Calibration cycle.....	2-5
Recommended equipment	2-5
Aborting calibration	2-5
Front panel calibration.....	2-6
Remote calibration	2-13

Manufacturing calibration	2-18
Recommended test equipment	2-19
Calibration card preparation	2-19
Unlocking manufacturing calibration	2-19
Measuring function generator signal amplitude	2-19
Front panel manufacturing calibration	2-20
Remote manufacturing calibration	2-21
Model 7700 calibration	2-21
Recommended test equipment	2-22
Calibration card connections	2-22
Model 7700 calibration	2-22
Routine maintenance	3-1
Introduction	3-1
Setting the line voltage and replacing the line fuse	3-1
Replacing the front terminal AMPS fuse	3-4
Replacing Model 7700 plug-in module amps fuses	3-5
Replacing non-volatile RAM battery	3-6
Plug-in module relay closure count	3-7
Closure count commands	3-7
Reading relay closure count	3-8
Resetting relay closure count	3-8
Setting count update interval	3-9
Troubleshooting	4-1
Introduction	4-1
Repair considerations	4-2
Power-on self-tests	4-2
RAM and EPROM tests	4-2
Flash memory tests	4-3
Front panel tests	4-3
KEY test	4-3
DISP test	4-4
Principles of operation	4-4
Power supply	4-5
Display board	4-6
Digital circuitry	4-8
Analog circuitry	4-9
Circuit troubleshooting	4-13
Display board checks	4-13
Power supply checks	4-13
Digital circuitry checks	4-14
Analog signal switching states	4-15
Disassembly	5-1
Introduction	5-1
Handling and cleaning	5-1

Handling PC boards	5-1
Solder repairs	5-2
Static sensitive devices	5-2
Assembly drawings	5-3
Disassembly procedures	5-3
Case cover removal	5-3
Motherboard removal	5-4
Card cage removal	5-4
Front panel disassembly	5-5
Removing power components	5-5
Instrument reassembly	5-6
Input terminal wire connections	5-7
Power module wire connections	5-7
Replaceable parts	6-1
Introduction	6-1
Ordering information	6-1
Factory service	6-1
Component layouts	6-2
Accuracy calculations	7-1
Introduction	7-1
Calculating DC characteristics accuracy	7-1
Calculating AC characteristics accuracy	7-2
Calculating dBm characteristics accuracy	7-2
Calculating dB characteristics accuracy	7-3
Additional derating factors	7-4
Optimizing measurement accuracy	7-4
DC voltage, DC current, and resistance	7-4
AC voltage and AC current	7-4
Temperature	7-4
Optimizing measurement speed	7-4
DC voltage, DC current, and resistance	7-4
AC voltage and AC current	7-4
Temperature	7-5
Calibration reference	8-1
Introduction	8-1
Command summary	8-2
Miscellaneous calibration commands	8-3
:CALibration:PROTeCted:CODE	8-3
:CALibration:PROTeCted:COUNT?	8-4
:CALibration:PROTeCted:DATA?	8-4
:CALibration:PROTeCted:DATE	8-5
:CALibration:PROTeCted:INITialize	8-5
:CALibration:PROTeCted:LOCK	8-6

:CALibration:PROTeCted:NDUE.....	8-7
:CALibration:PROTeCted:SAVE	8-7
DC calibration commands	8-8
:CALibration:PROTeCted:DC:STEP<step>	8-9
AC calibration commands	8-10
:CALibration:PROTeCted:AC:STEP<step>.....	8-11
Manufacturing calibration commands	8-12
:CALibration:PROTeCted:AC:STEP<14 15>	8-12
:CALibration:PROTeCted:DC:STEP0	8-13
Model 7700 calibration commands	8-13
:CALibration:PROTeCted:CODE	8-14
:CALibration:PROTeCted:CARD1:INITiate	8-15
:CALibration:PROTeCted:CARD1:COUnT?	8-15
:CALibration:PROTeCted:CARD1:RCUnT.....	8-16
:CALibration:PROTeCted:CARD1:DATE?	8-16
:CALibration:PROTeCted:CARD1:SAVE	8-17
:CALibration:PROTeCted:CARD1:LOCK.....	8-17
:CALibration:PROTeCted:CARD1:STEP0	8-18
Remote error reporting	8-18
Error summary	8-19
Error queue	8-20
Status byte EAV (Error Available) bit	8-20
Detecting calibration step completion	8-21

Performance verification

In this section:

Introduction	1-1
Verification test requirements.....	1-2
Recommended test equipment	1-3
Verification limits	1-3
Restoring factory defaults.....	1-4
Performing the verification test procedures.....	1-5
Model 2701 verification	1-6
Model 7700 verification	1-16

Introduction

Use the procedures in this section to verify that 2701 Ethernet Multimeter/Data Acquisition System accuracy is within the limits stated in the instrument's one-year accuracy specifications. You can perform these verification procedures:

- Upon receiving the instrument, to make sure it was not damaged during shipment and the unit meets factory specifications.
- If the instrument's accuracy is questionable.
- Following calibration.

WARNING

The information in this section is intended only for qualified service personnel. Do not attempt these procedures unless you are qualified to do so.

NOTE

If the instrument is still under warranty and its performance is outside specified limits, contact your Keithley representative or the factory to determine the correct course of action. If the unit is not under warranty and it fails to meet specified limits, refer to the calibration procedures in the next section.

There are two general verification procedures in this section:

- 2701 verification — Covers procedures to verify measurement accuracy of the 2701 using the front panel terminals.
- 7700 verification — Discusses procedures to verify accuracy of measurements made through the 7700 20-Channel Multiplexer. Note that the same general procedures can be used to verify measurement accuracy of other 2701 plug-in modules that have similar functions. For specific information about the individual modules, refer to the appropriate appendices in the *2701 User's Manual*.

Verification test requirements

Be sure that you perform the verification tests:

- Under the proper environmental conditions.
- After the specified warm-up period.
- Using the correct line voltage.
- Using the proper calibration equipment.
- Using the specified reading limits.

Environmental conditions

Conduct your performance verification procedures in a test environment that has:

- An ambient temperature of 18 °C to 28 °C.
- A relative humidity of less than 80% unless otherwise noted.

Warm-up period

Allow the 2701 to warm up for at least two hours before conducting the verification procedures.

If the instrument has been subjected to temperature extremes (those outside the ranges stated above), allow additional time for the instrument's internal temperature to stabilize. Typically, allow one extra hour to stabilize a unit that is 10 °C outside the specified temperature range.

Also, allow the test equipment to warm up for the minimum time specified by the manufacturer.

Line power

The 2701 requires a line voltage of 100 V/120 V/220 V/240 V \pm 10% and a line frequency of 45 Hz to 66 Hz or 360 Hz to 440 Hz. Note that the line frequency is automatically sensed at power-up, but the line voltage must be manually set to either 100 V/120 V or 220 V/240 V.

Recommended test equipment

The next table summarizes recommended verification equipment. You can use alternate equipment if that equipment has specifications at least as good as those listed. Keep in mind, however, that calibrator uncertainty will add to the uncertainty of each measurement.

Fluke 5700A Calibrator:				
DC voltage	AC voltage (1 kHz, 50 kHz)	DC current	AC current (1 kHz)	Resistance
100 mV ±14 ppm 1.0 V ±7 ppm 10 V ±5 ppm 100 V ±7 ppm 1000 V ±9 ppm	100 mV ±200 ppm 1.0 V ±82 ppm 10 V ±82 ppm 100 V ±90 ppm 700 V ±85 ppm	20 mA ±60 ppm 100 mA ±70 ppm 1 A ±110 ppm 2.2 A ±94 ppm	1 A ±690 ppm 2.2 A ±682 ppm	100 Ω ±17 ppm 1 kΩ ±12 ppm 10 kΩ ±11 ppm 100 kΩ ±13 ppm 1 MΩ ±18 ppm 10 MΩ ±37 ppm 100 MΩ ±120 ppm
Fluke 5725A Amplifier:				
AC Voltage, 50 kHz, 700 V, ±375 ppm DC Current, 3 A, ±500 ppm AC Current, 1 kHz, 3 A, ±457 ppm				
Stanford Research Systems DS345 Function Generator:				
1 V RMS 1 kHz, ±5 ppm				
General Radio 1433-T Precision Decade Resistance Box:				
10 Ω to 400 Ω, ±0.02%				
Miscellaneous Equipment:				
Double banana plug to double banana plug shielded cables (2) BNC to double banana plug shielded cable				

NOTE

The Fluke 5725A amplifier is necessary only if you wish to verify the 750 VAC range at 50 kHz and 3 A AC and DC current ranges at 3 A. Verification at 220 V, 50 kHz, and 2.2 A on the current ranges using only the 5700A calibrator is adequate for most applications.

Verification limits

The verification limits stated in this section have been calculated using only the 2701 one-year accuracy specifications, and they do not include test equipment uncertainty. If a particular measurement falls slightly outside the allowable range, recalculate new limits based on both 2701 specifications and pertinent calibration equipment specifications.

Example reading limit calculation

The following is an example of how reading limits have been calculated. Assume you are testing the 10 VDC range using a 10 V input value. Using the 2701 one-year accuracy specification for 10 VDC of \pm (30 ppm of reading + 5 ppm of range), the calculated limits are:

$$\text{Reading limits} = 10 \text{ V} \pm [(10 \text{ V} \times 30 \text{ ppm}) + (10 \text{ V} \times 5 \text{ ppm})]$$

$$\text{Reading limits} = 10 \text{ V} \pm (0.0003 + 0.00005)$$

$$\text{Reading limits} = 10 \text{ V} \pm 0.00035 \text{ V}$$

$$\text{Reading limits} = 9.99965 \text{ V to } 10.00035 \text{ V}$$

Calculating resistance reading limits

Resistance reading limits must be recalculated based on the actual calibration resistance values supplied by the equipment manufacturer. Calculations are performed in the same manner as shown in the preceding example, except, of course, that you should use the actual calibration resistance values instead of the nominal values when performing your calculations.

For example, assume that you are testing the 10 k Ω range using an actual 10.03 k Ω calibration resistance value. Using 2701 one-year 10 k Ω range accuracy of \pm (100 ppm of reading + 6 ppm of range), the calculated reading limits are:

$$\text{Reading limits} = 10.03 \text{ k}\Omega \pm [(10.03 \text{ k}\Omega \times 100 \text{ ppm}) + (10 \text{ k}\Omega \times 6 \text{ ppm})]$$

$$\text{Reading limits} = 10.02894 \text{ k}\Omega \text{ to } 10.03106 \text{ k}\Omega$$

Restoring factory defaults

Before performing the verification procedures, restore the instrument to its factory defaults as follows:

1. Press **SHIFT** and then **SETUP**. The instrument will display `RESTORE: FACT`.
2. Using either range key, select `FACT`, then restore the factory default conditions by pressing **ENTER**.

Performing the verification test procedures

Verification test summary

Verification tests can be performed either through the 2701 front panel terminals or through plug-in modules. This section contains the following procedures:

- 2701 verification — Use this procedure to test 2701 accuracy through the front panel terminals.
- 7700 verification — Use this procedure to test accuracy through any of the available plug-in modules with the same functions as the 7700 20-Channel Multiplexer Card.

Model 2701 tests

2701 verification test procedures include:

- DC volts
- AC volts
- DC current
- AC current
- Resistance
- Temperature
- Frequency

Model 7700 tests

7700 verification test procedures include:

- DC volts
- AC volts
- DC current
- AC current
- Resistance
- Temperature
- Frequency
- Ratio and average

Test considerations

When performing the verification procedures:

- Be sure to restore factory defaults as outlined above.
- Make sure that the equipment is properly warmed up and connected to the correct input terminals. Also, make sure that the INPUTS switch is in the correct position.
- Do not use autoranging for any verification tests, because autorange hysteresis may cause the 2701 to be on an incorrect range. For each test signal, you must manually set the correct range for the 2701 using the range keys.
- Make sure the calibrator is in operate before you verify each measurement.
- Always let the source signal settle before taking a reading.

WARNING

Observe the following safety precautions when performing these tests:

- Some of the procedures in this section may expose you to dangerous voltages. Use standard safety precautions when such dangerous voltages are encountered to avoid personal injury or death caused by electric shock.
- For the front panel terminals only, the maximum common-mode voltage (voltage between INPUT LO and chassis ground) is 500 V_{PEAK} . Exceeding this value may cause a breakdown in insulation, creating a shock hazard.
- For the plug-in modules, the maximum common-mode voltage (voltage between any plug-in module terminal and chassis ground) is 300 VDC or 300 V_{RMS} . Exceeding this value may cause a breakdown in insulation, creating a shock hazard.
- When using the front panel terminals simultaneously with plug-in modules, all cable insulation voltage ratings must equal or exceed the maximum voltage applied to either the front panel terminals or the plug-in module terminals.

Model 2701 verification

Perform these tests to verify accuracy using the 2701 front panel terminals.

Verifying DC voltage

Check DC voltage accuracy by applying accurate voltages from the DC voltage calibrator to the 2701 INPUT jacks and verifying that the displayed readings fall within specified limits.

CAUTION

Do not exceed 1000 V_{PEAK} between front terminals INPUT HI and INPUT LO because instrument damage may occur.

To verify DC voltage accuracy:

1. Connect the 2701 HI and LO INPUT jacks to the DC voltage calibrator as shown in the next figure. Make sure the INPUTS switch is set to the FRONT position.

NOTE

Use shielded, low-thermal connections when testing the 100 mV and 1 V ranges to avoid errors caused by noise or thermal effects. Connect the shield to the calibrator's output LO terminal.

Figure 1: Connections for 2701 DC volts verification

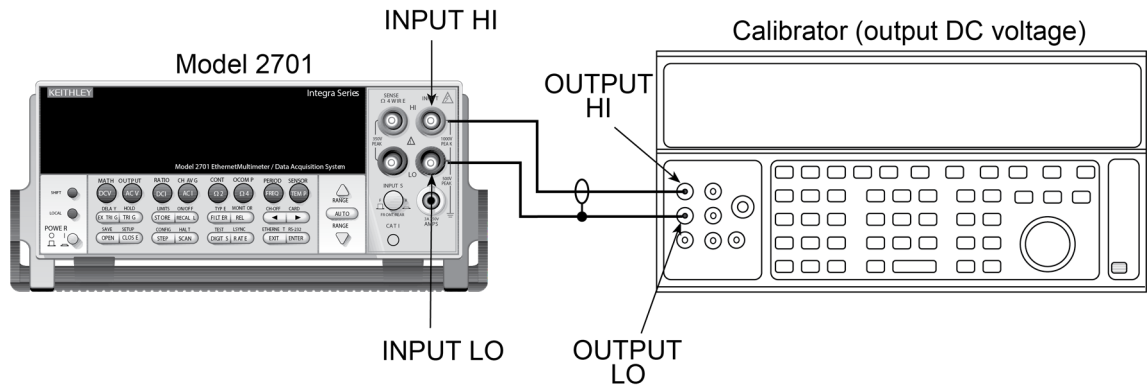

2. Select the DC volts function by pressing the **DCV** key and set the 2701 to the 100 mV range.
3. Set the calibrator output to 0.00000 mV DC and allow the reading to settle.
4. Enable the 2701 REL mode. Leave REL enabled for the remainder of the DC volts verification tests.
5. Source positive and negative and full-scale voltages for each of the ranges listed in the next table. For each voltage setting, be sure that the reading is within stated limits.

Range	Applied DC voltage*	Reading limits (1 year, 18 °C to 28 °C)
100 mV	100.0000 mV	99.9935 mV to 100.0065 mV
1 V	1.000000 V	0.999963 V to 1.000037 V
10 V	10.00000 V	9.99965 V to 10.00035 V
100 V	100.0000 V	99.9946 V to 100.0054 V
1000 V	1000.000 V	999.941 V to 1000.059 V

*Source positive and negative values for each range.

Verifying AC voltage

Check AC voltage accuracy by applying accurate AC voltages at specific frequencies from the AC voltage calibrator to the 2701 inputs and verifying that the displayed readings fall within specified ranges. An amplifier is only required for 700 V, 50 kHz output.

CAUTION

Do not exceed 1000 V_{PEAK} between front terminals INPUT HI and INPUT LO, or 8×10^7 V·Hz input. Damage to your instrument may occur.

To verify AC voltage accuracy:

1. Connect the 2701 HI and LO INPUT jacks to the AC voltage calibrator as shown in the next figure. Be sure the INPUTS switch is in the FRONT position.

Figure 2: Connections for 2701 AC volts verification

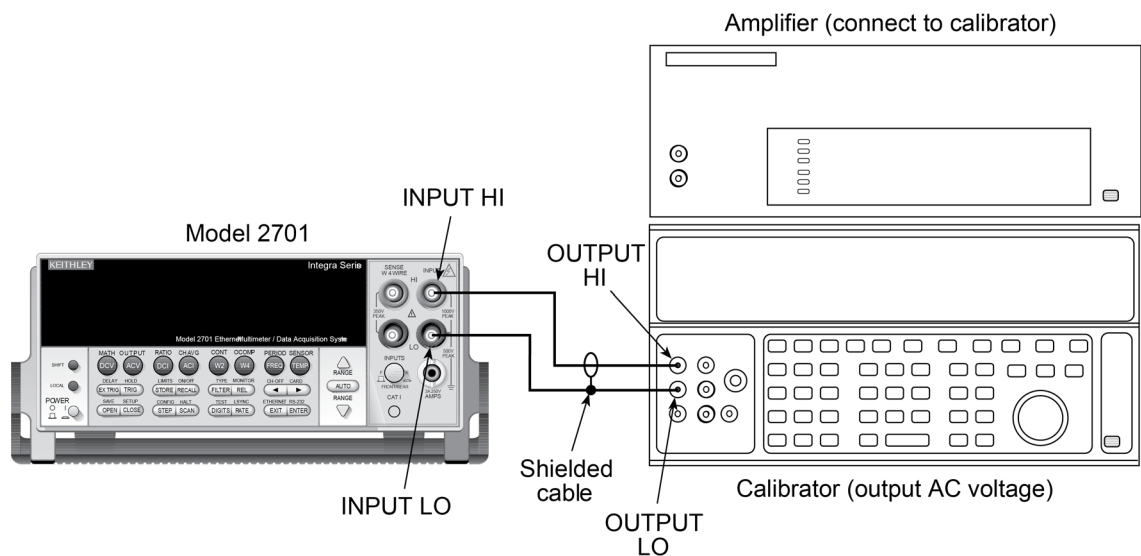

2. Select the AC volts function by pressing the **ACV** key.
3. Set the 2701 for the 100 mV range; make sure that REL is disabled.
4. Source 1 kHz and 50 kHz AC voltages for each of the ranges summarized in the next table and make sure that the respective 2701 readings fall within stated limits.

ACV range	Applied AC voltage	1 kHz reading limits (1 year, 18 °C to 28 °C)	50 kHz reading limits (1 year, 18 °C to 28 °C)
100 mV	100.0000 mV	99.910 mV to 100.090 mV	99.830 mV to 100.170 mV
1 V	1.000000 V	0.99910 V to 1.00090 V	0.99830 V to 1.00170 V
10 V	10.00000 V	9.9910 V to 10.0090 V	9.98300 V to 10.0170 V
100 V	100.0000 V	99.910 V to 100.090 V	99.830 V to 100.170 V
750 V	700.000 V	699.36 V to 700.64 V	698.79 V to 701.21 V

*If the 5725A amplifier is not available, change the 700 V @ 50 kHz step to 220 V @ 50 kHz.
Reading limits for 220 V @ 50 kHz = 219.36 V to 220.64 V.

Verifying DC current

Check DC current accuracy by applying accurate DC currents from the DC current calibrator to the AMPS input of the 2701 and verifying that the displayed readings fall within specified limits.

To verify DC current accuracy:

1. Connect the 2701 AMPS and INPUT LO jacks to the calibrator as shown in the next figure.

NOTE

Be sure that the INPUTS switch is in the FRONT position and the calibrator is set for normal current output.

Figure 3: Connections for 2701 DC current verification

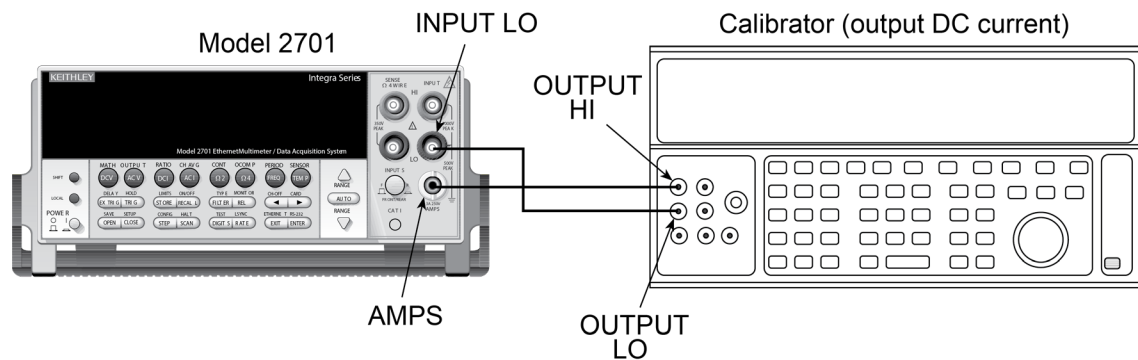

2. Select the DC current measurement function by pressing the **DCI** key.
3. Set the 2701 for the 20 mA range.
4. Source positive and negative full-scale currents for each of the ranges listed in the next table and verify that the readings for each range are within stated limits.

DCI range	Applied DC current*	Reading limits (1 year, 18 °C to 28 °C)
20 mA	20.0000 mA	19.98840 mA to 20.011160 mA
100 mA	100.0000 mA	99.8700 mA to 100.1300 mA
1 A	1.000000 A	0.999120 A to 1.000880 A
3 A	3.000000 A**	2.99628 A to 3.00372 A

*Source positive and negative currents with values shown.

**If the Fluke 5725 amplifier is not available, apply 2.2 A from calibrator. Reading limits for 2.2 A input are: 2.197240 A to 2.202760 A.

Verifying AC current

Check AC current accuracy by applying accurate AC voltage current at specific frequencies from the AC current calibrator to the 2701 input, verifying that the displayed readings fall within specified limits.

To verify AC current accuracy:

1. Connect the 2701 AMPS and INPUT LO jacks to the calibrator as shown in the next figure. Be sure the INPUTS switch is in the FRONT position.

Figure 4: Connections for 2701 AC current verification

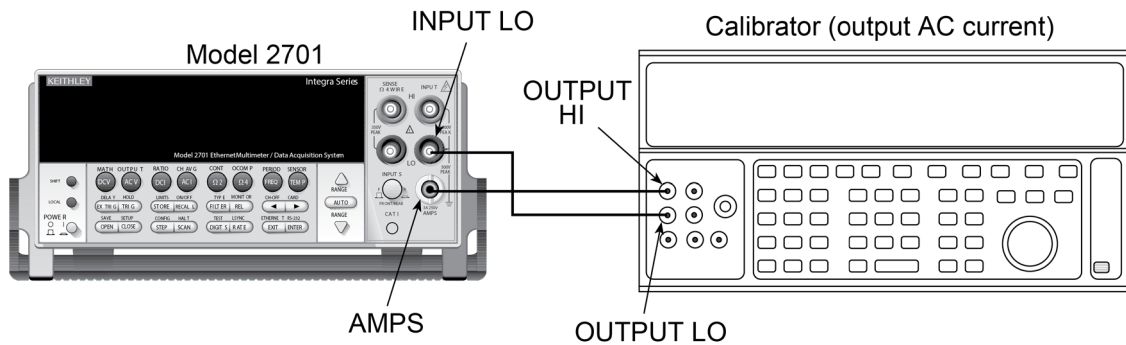

2. Select the AC current function by pressing the **ACI** key.
3. Set the 2701 for the 1 A range.
4. Source 1 A and 3 A, 1 kHz full-scale AC currents as summarized in the next table, and verify that the readings are within stated limits.

ACV range	Applied AC voltage	Reading limits @ 1 kHz (1 year, 18 °C to 28 °C)
1 A	1.000000 A	0.99860 A to 1.00140 A
3 A	3.00000 A*	2.9817 A to 3.0183 A

*If the Fluke 5725A amplifier is not available, apply 2.2 A from the calibrator. Reading limits for 2.2 A are 2.1949 A to 2.2051 A.

Verifying resistance

Check resistance by connecting accurate resistance values to the 2701 and verifying that its resistance readings are within the specified limits.

CAUTION

Do not apply more than 1000 V_{peak} between front terminals INPUT HI and LO or more than 350 V_{peak} between SENSE HI and LO, or instrument damage could occur.

To verify resistance accuracy:

1. Using shielded, Teflon-insulated or equivalent cables in a 4-wire configuration, connect the 2701 INPUT and SENSE jacks to the calibrator as shown in the next figure. Be sure the INPUTS switch is in the FRONT position.

Figure 5: Connections for 2701 resistance verification, 100 ohm to 10 M ohm ranges

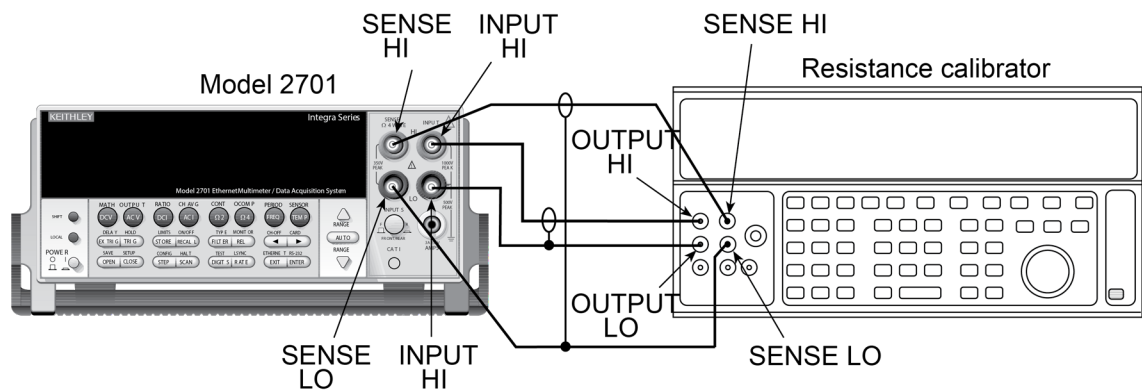

2. Set the calibrator for 4-wire resistance with external sense on.
3. Select the 2701 4-wire resistance function by pressing the **Ω4** key, then choose the **SLOW** integration rate with the **RATE** key.
4. Set the 2701 for the 100 Ω range and make sure the FILTER is on. Enable OCOMP (offset-compensated ohms) for 100 Ω range verification. (Press **SHIFT** then OCOMP.)
5. Recalculate reading limits based on actual calibrator resistance values.
6. Source the nominal full-scale resistance values for the 100 Ω through 10 MΩ ranges summarized in the next table and verify that the readings are within calculated limits.
7. Connect the 2701 INPUT and SENSE jacks to the calibrator as shown in the next figure.
8. Disable external sense on the calibrator.
9. Set the 2701 for the 100 MΩ range.
10. Source a nominal 100 MΩ resistance value and verify that the reading is within calculated limits for the 100 MΩ range.

Figure 6: Connections for 2701 resistance verification, 100 M ohm range

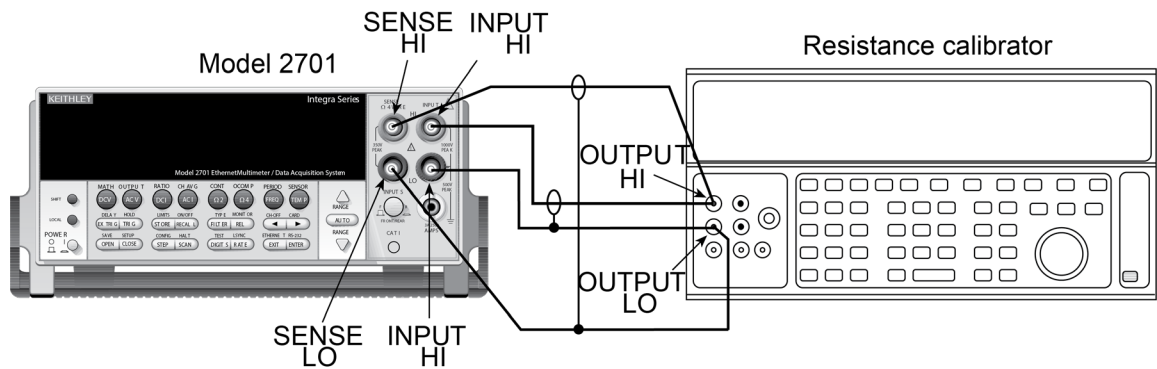

Ω Range	Nominal resistance	Nominal reading limits (1 year, 18 °C to 28 °C)	Recalculated limits**
100 Ω*	100 Ω	99.9880 Ω to 100.0120 Ω	_____ to _____ Ω
1 kΩ	1 kΩ	0.999894 Ω to 1.000106 kΩ	_____ to _____ kΩ
10 kΩ	10 kΩ	9.99894 Ω to 10.00106 kΩ	_____ to _____ kΩ
100 kΩ	100 kΩ	99.9890 Ω to 100.0110 kΩ	_____ to _____ kΩ
1 MΩ	1 MΩ	0.999890 Ω to 1.000110 MΩ	_____ to _____ MΩ
10 MΩ	10 MΩ	9.99590 Ω to 10.00410 MΩ	_____ to _____ MΩ
100 MΩ	100 MΩ	99.7970 Ω to 100.2030 MΩ	_____ to _____ MΩ

*Enable O COMP (offset-compensated ohms) when testing 100 Ω range.

**Calculate limits based on actual calibration resistance values and 2701 one-year resistance accuracy specifications.

Verifying temperature

Thermocouple, thermistor, and RTD temperature readings are derived from DC volts and resistance measurements, respectively. For that reason, it is not necessary to independently verify the accuracy of temperature measurements. As long as the DC volts and resistance functions meet or exceed specifications, temperature function accuracy is automatically verified. However, temperature verification procedures are provided below for those who wish to separately verify temperature accuracy.

Thermocouple temperature

To verify the thermocouple accuracy:

1. Connect the DC voltage calibrator output terminals to the 2701 INPUT jacks using low-thermal, shielded, 2-wire connections. Be sure the INPUTS switch is in the FRONT position.
2. Configure the 2701 for °C units, type J temperature sensor, and 0 °C simulated reference junction:
 - a. Press **SHIFT** then **SENSOR** and note the unit displays the temperature units: UNITS: C. (If necessary, use the cursor and range keys to select °C units.)
 - b. Press **ENTER**. The unit displays the sensor type: SENS: TCOUPLE.
 - c. Make sure that TCOUPLE is displayed, then press **ENTER**. The unit then displays the thermocouple type: TYPE: K.
 - d. Select a type J temperature sensor, then press **ENTER**. The unit then displays the reference junction type: JUNC: SIM.
 - e. Make certain that the simulated reference junction type is selected, then press **ENTER**. The unit then displays the current simulated reference junction temperature: SIM: 023.
 - f. Using the cursor and range keys, set the reference junction temperature to 0 °C, then press **ENTER** twice to complete the temperature configuration process.
3. Select the temperature function by pressing the **TEMP** key.
4. Source each of the voltages summarized in the next table and verify that the temperature readings are within limits. Be sure to select the appropriate thermocouple type for each group of readings.

Thermocouple type	Applied DC voltage*	Reading limits (1 year, 18 °C to 28 °C)
J	-7.659 mV	-190.2 °C to -189.8 °C
	0 mV	-0.2 °C to +0.2 °C
	42.280 mV	749.8 °C to 750.2 °C
K	-5.730 mV	-190.2 °C to -189.8 °C
	0 mV	-0.2 °C to +0.2 °C
	54.138 mV	1349.8 °C to 1350.2 °C

*Voltages shown are based on ITS-90 standard using 0 °C reference junction temperature. See text for procedure to set reference junction temperature.

RTD temperature

To verify the RTD temperature:

1. Connect the precision decade resistance box to the 2701 INPUT and SENSE jacks using four-wire connections. Be sure the INPUTS switch is in the FRONT position.
2. Configure the 2701 temperature function for °C units and RTD temperature sensor ($\alpha=0.00385$):
 - a. Press **SHIFT** then **SENSOR** and note the unit displays the temperature units: UNITS: C.
 - b. Press **ENTER** and note the unit displays the sensor type: SENS: TCOUPLE.
 - c. Using the cursor and range keys, set the display as follows: SENS: 4W-RTD.
 - d. Press **ENTER** and note the unit displays: TYPE: PT100.
 - e. Using the cursor and range keys, set the unit for the following display: TYPE: PT385.
 - f. Press **ENTER** to complete the temperature configuration process.
3. Select the temperature function by pressing the **TEMP** key.
4. Set the decade resistance box to each of the values shown in the next table and verify that the temperature readings are within the required limits.

Applied resistance*	Reading limits (1 year, 18 °C to 28 °C)
22.80 Ω	-190.06 °C to -189.94 °C
100.00 Ω	-0.06 to °C to +0.06 °C
313.59 Ω	599.94 °C to 600.06 °C

*Based on $\alpha = 0.00385$. See text.

Type	Standard	Alpha	Beta	Delta	Ω at 0 °C
PT100	ITS-90	0.00385055	0.10863	1.49990	100 Ω
D100	ITS-90	0.003920	0.10630	1.49710	100 Ω
F100	ITS-90	0.003900	0.11000	1.49589	100 Ω
PT385	IPTS-68	0.003850	0.11100	1.50700	100 Ω
PT3916	IPTS-68	0.003916	0.11600	1.50594	100 Ω

Verifying frequency

To verify the 2701 frequency function:

1. Connect the function generator to the 2701 INPUT jacks. Be sure the INPUTS switch is in the FRONT position.

Figure 7: Connections for 2701

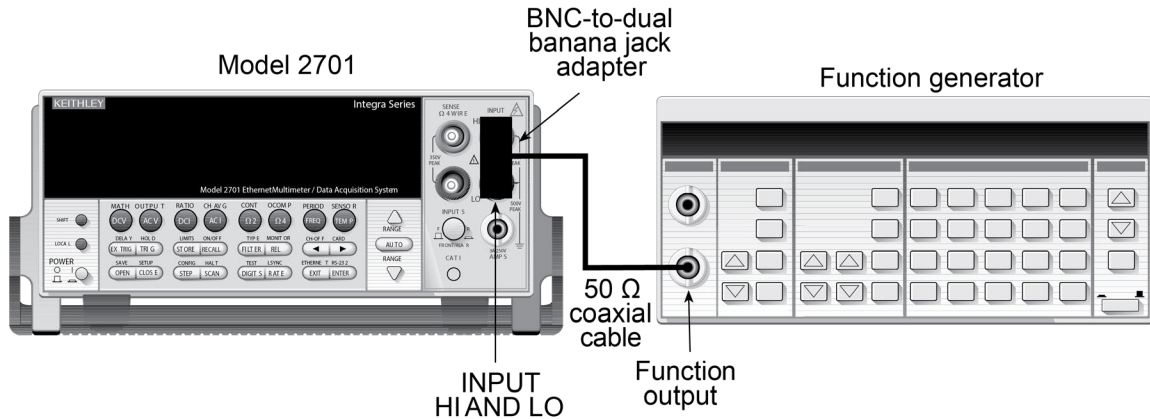

2. Set the function generator to output a 1 kHz, 1 V RMS sine wave.
3. Select the 2701 frequency function by pressing the **FREQ** key.
4. Verify that the 2701 frequency reading is between 999.9 Hz and 1.0001 kHz.

Model 7700 verification

Use these procedures to verify measurement accuracy through the 7700 20-Channel Multiplexer Card.

NOTE

Although the following tests are based on the 7700 20-Channel Multiplexer, the same general procedures can be used for other plug-in modules that have similar capabilities. Refer to the *2701 User's Manual* for specific information on terminals and connections for other plug-in modules.

Verifying DC voltage

Check DC voltage accuracy by applying accurate voltages from the DC voltage calibrator to the 7700 input terminals and verifying that the displayed readings fall within specified limits.

CAUTION

Do not exceed 300 VDC between plug-in module INPUT H and L terminals or between any adjacent channels.

To verify DC voltage accuracy:

1. Connect the 7700 CH1 H and L INPUT terminals to the DC voltage calibrator as shown in the next figure.

NOTE

Use shielded, low-thermal connections when testing the 100 mV and 1 V ranges to avoid errors caused by noise or thermal effects. Connect the shield to the calibrator's output LO terminal.

Figure 8: Connections for 7700 DC volts verification

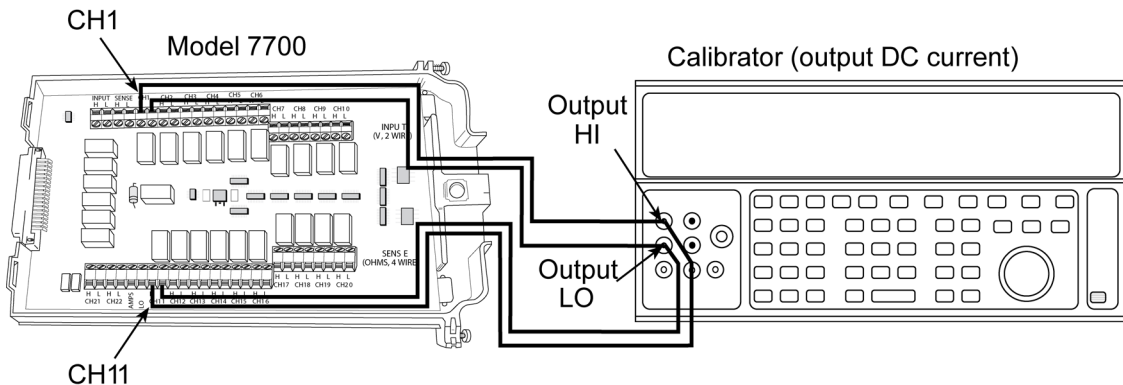

2. Install the 7700 in slot 1 of the 2701, then turn on the power and allow the unit to warm up for two hours before proceeding. Be sure the front panel INPUTS switch is set to the REAR position.
3. Select the DC volts function by pressing the **DCV** key and set the 2701 to the 100 mV range. Close Channel 1 by pressing the **CLOSE** key and entering 101.
4. Set the calibrator output to 0.00000 mVDC and allow the reading to settle.
5. Enable the 2701 REL mode. Leave REL enabled for the remainder of the DC volts verification tests.
6. Source positive and negative and full-scale voltages for each of the ranges listed in the next table. For each voltage setting, be sure that the reading is within stated limits.
7. Press the **OPEN** key to open Channel 1.

Range	Applied DC voltage*	Reading limits (1 year, 18 °C to 28 °C)
100 mV	100.0000 mV	99.9935 mV to 100.0065 mV
1 V	1.000000 V	0.999963 V to 1.000037 V
10 V	10.00000 V	9.99965 V to 10.00035 V
100 V	100.0000 V	99.9946 V to 100.0054 V
1000 V	300.000 V	299.976 V to 300.024 V

*Source positive and negative values for each range.

Verifying AC voltage

Check AC voltage accuracy by applying accurate AC voltages at specific frequencies from the AC voltage calibrator to the 7700 inputs and verifying that the displayed readings fall within specified ranges.

CAUTION

Do not exceed 300 V RMS between plug-in module INPUT H and L terminals or between adjacent channels, or 8×10^7 V·Hz input. Instrument damage may occur.

To verify AC voltage accuracy:

1. Connect the 7700 CH1 H and L INPUT terminals to the AC voltage calibrator as shown in the next figure.

Figure 9: Connections for 7700 AC volts verification

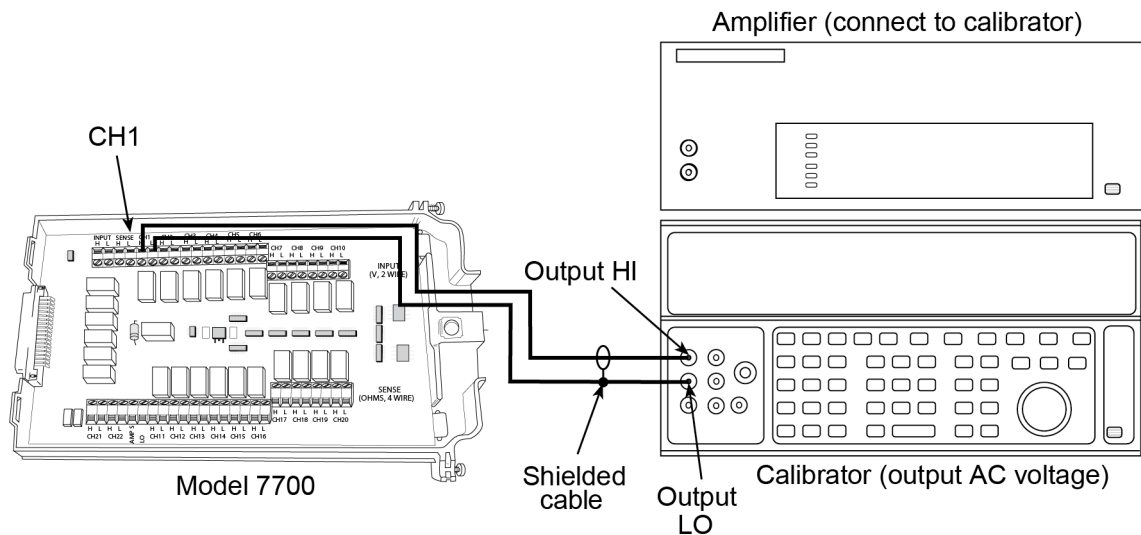

2. Install the 7700 in Slot 1 of the 2701, then turn on the power and allow the unit to warm up for two hours before proceeding. Be sure the front panel INPUTS switch is set to the REAR position.
3. Select the AC volts function by pressing the **ACV** key. Close Channel 1 by pressing the **CLOSE** key and then entering 101.
4. Set the 2701 for the 100 mV range and make sure that REL is disabled.
5. Source 1 kHz and 50 kHz AC voltages for each of the ranges summarized in the next table. Be sure that the respective 2701 readings fall within stated limits.
6. Press the **OPEN** key to open Channel 1.

ACV range	Applied AC voltage	1 kHz reading limits (1 year, 18 °C to 28 °C)	50 kHz reading limits (1 year, 18 °C to 28 °C)
100 mV	100.0000 mV	99.910 mV to 100.090 mV	99.830 mV to 100.170 mV
1 V	1.000000 V	0.99910 V to 1.00090 V	0.99830 V to 1.00170 V
10 V	10.00000 V	9.9910 V to 10.0090 V	9.98300 V to 10.0170 V
100 V	100.0000 V	99.910 V to 100.090 V	99.830 V to 100.170 V
750 V	300.000 V*	299.60 V to 300.40 V	299.27 V to 300.73 V

*If the 5725A amplifier is not available, change the 300 V @ 50 kHz step to 220 V @ 50 kHz. Reading limits for 220 V @ 50 kHz = 219.36 V to 220.64 V.

Verifying DC current

Check DC current accuracy by applying accurate DC currents from the DC current calibrator to the input terminals of the Model 7700 and verifying that the displayed readings fall within specified limits.

To verify DC current accuracy:

1. Connect the 7700 CH21 H and L terminals to the calibrator as shown in the next figure.

Figure 10: Connections for 7700 DC current verification

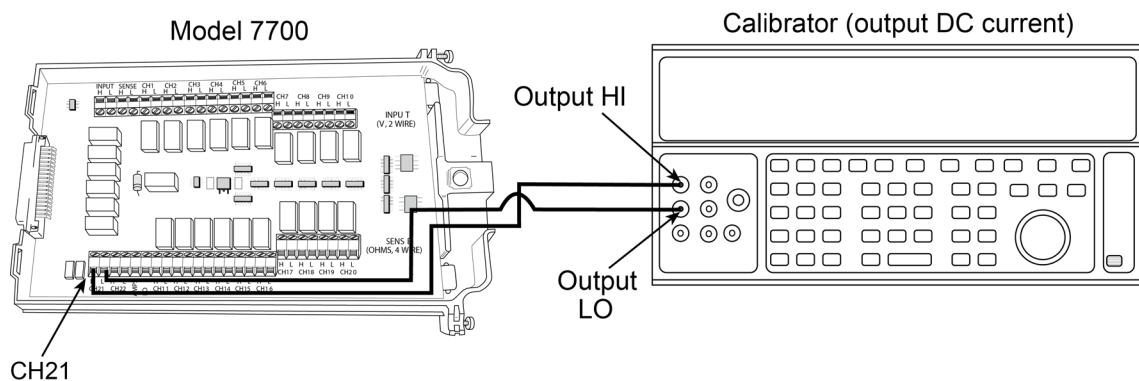

2. Install the 7700 in Slot 1 of the 2701, then turn on the power and allow the unit to warm up for two hours before proceeding. Be sure the front panel INPUTS switch is set to the REAR position.
3. Select the DC current measurement function by pressing the **DCI** key.
4. Set the 2701 for the 20 mA range. Close channel 21 by pressing the **CLOSE** key and entering 121.
5. Source positive and negative full-scale currents for each of the ranges listed in the next table. Verify that the readings for each range are within stated limits.
6. Press the **OPEN** key to open channel 21.

DCI range	Applied DC current*	Reading limits (1 year, 18 °C to 28 °C)
20 mA	20.0000 mA	19.98840 mA to 20.01160 mA
100 mA	100.0000 mA	99.8700 mA to 100.1300 mA
1 A	1.000000 A	0.999120 A to 1.000880 A
3 A	3.000000 A**	2.99628 A to 3.00372 A

*Source positive and negative currents with values shown.

**If the Fluke 5725 amplifier is not available, apply 2.2 A from calibrator. Reading limits for 2.2 A input are: 2.197240 A to 2.202760 A.

Verifying AC current

Check AC current accuracy by applying accurate AC voltage current at specific frequencies from the AC current calibrator to the 7700 input terminals and verifying that the displayed readings fall within specified limits.

To verify AC current:

1. Connect the 7700 CH21 H and L terminals to the calibrator as shown in the next figure.

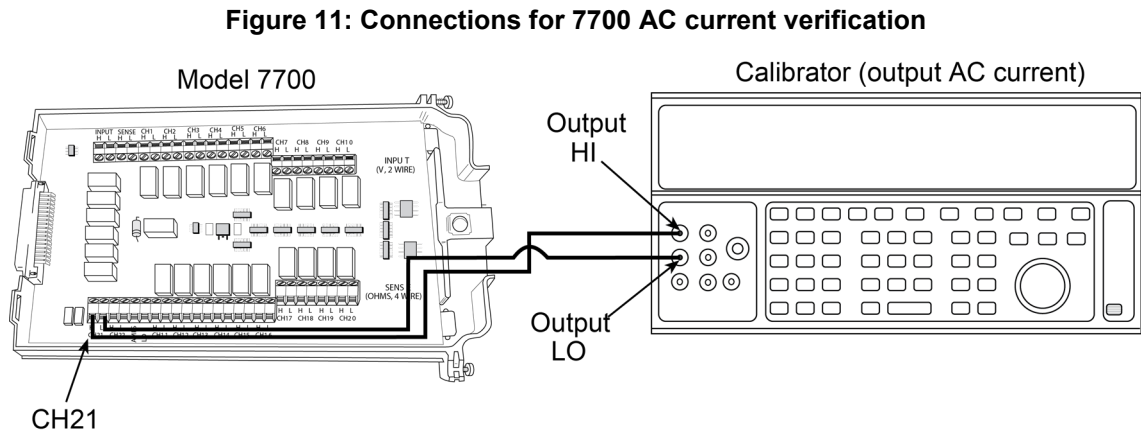

2. Install the 7700 in slot 1 of the 2701, then turn on the power and allow the unit to warm up for two hours before proceeding. Be sure the front panel INPUTS switch is set to the REAR position.
3. Select the AC current function by pressing the **ACI** key.
4. Set the 2701 for the 1 A range. Close channel 21 by pressing the **CLOSE** key and entering 121.
5. Source 1 A and 3 A, 1 kHz full-scale AC currents as summarized in the next table. Verify that the readings are within stated limits.
6. Press the **OPEN** key to open channel 21.

ACV range	Applied AC voltage	Reading limits @ 1 kHz (1 year, 18 °C to 28 °C)
1 A	1.000000 A	0.99860 A to 1.00140 A
3 A	3.00000 A*	2.9817 A to 3.0183 A

*If the Fluke 5725A amplifier is not available, apply 2.2 A from the calibrator. Reading limits for 2.2 A are 2.1949 A to 2.2051 A.

Verifying resistance

Check resistance by connecting accurate resistance values to the 7700 and verifying that its resistance readings are within the specified limits.

CAUTION

Do not apply more than 300 V between plug-in module INPUT or SENSE H and L terminal, or between any adjacent channels. Instrument damage could occur.

To verify resistance accuracy:

1. Using shielded Teflon or equivalent cables in a 4-wire configuration, connect the 7700 CH1 H and L INPUT terminals and CH11 H and L SENSE terminals to the calibrator as shown in the next figure.

Figure 12: Connections for 7700 resistance verification, 100 ohm to 10 M ohm ranges

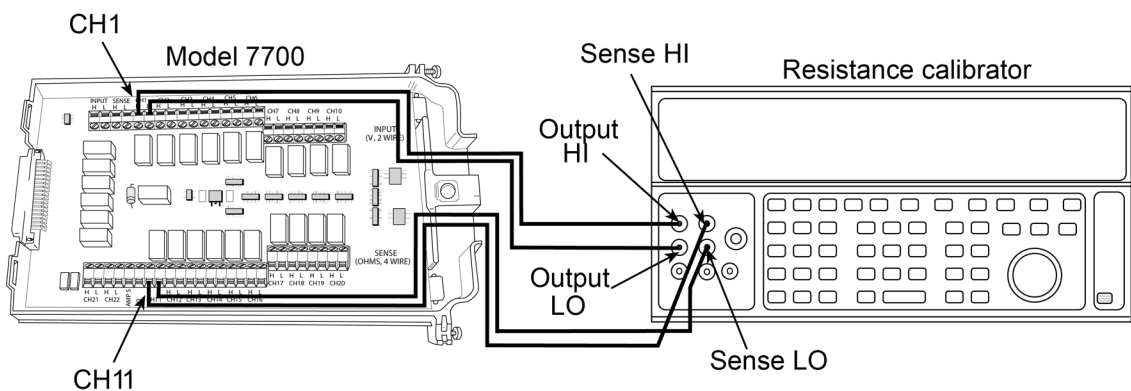

2. Install the 7700 in slot 1 of the 2701, then turn on the power and allow the unit to warm up for two hours before proceeding. Be sure the front panel INPUTS switch is set to the REAR position.
3. Set the calibrator for 4-wire resistance with external sense on.
4. Select the 2701 4-wire resistance function by pressing the **Ω4** key. Close channel 1 by pressing the **CLOSE** key and entering 101.
5. Set the 2701 for the 100 Ω range and make sure the FILTER is on. Enable OCOMP (offset-compensated ohms) for the 100 Ω range test.
6. Recalculate reading limits based on actual calibrator resistance values.
7. Source the nominal full-scale resistance values for the 100 Ω to 10 MΩ ranges summarized in the next table and verify that the readings are within calculated limits.

Ω Range	Nominal resistance	Nominal reading limits (1 year, 18 °C to 28 °C)	Recalculated limits**
100 Ω*	100 Ω	99.9880 Ω to 100.0120 Ω	_____ to _____ Ω
1 kΩ	1 kΩ	0.999894 Ω to 1.000106 kΩ	_____ to _____ kΩ
10 kΩ	10 kΩ	9.99894 Ω to 10.00106 kΩ	_____ to _____ kΩ
100 kΩ	100 kΩ	99.9890 Ω to 100.0110 kΩ	_____ to _____ kΩ
1 MΩ	1 MΩ	0.999890 Ω to 1.000110 MΩ	_____ to _____ MΩ
10 MΩ	10 MΩ	9.99370 Ω to 10.00630 MΩ	_____ to _____ MΩ
100 MΩ	100 MΩ	99.5770 Ω to 100.4230 MΩ	_____ to _____ MΩ

*Enable OCOMP for 100 Ω range.

**Calculate limits based on actual calibration resistance values and 2701 one-year resistance accuracy specifications.

8. Connect the 7700 CH1 and CH11 terminals to the calibrator as shown in the next figure.

Figure 13: Connections for 7700 resistance verification, 100 M ohm range

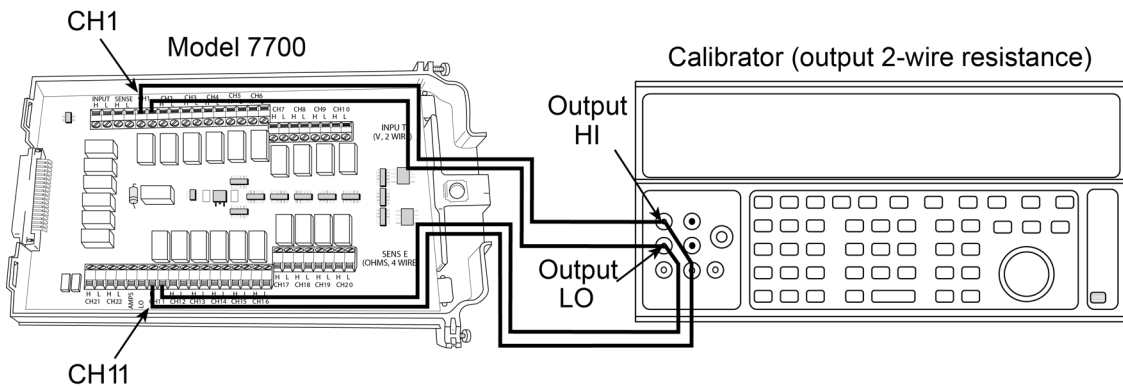

9. Disable external sense on the calibrator.
10. Set the 2701 for the 100 M Ω range.
11. Source a nominal 100 M Ω resistance value and verify that the reading is within calculated limits for the 100 M Ω range.
12. Press the **OPEN** key to open channel 1.

Verifying temperature

Thermocouple, thermistor, and RTD temperature readings are derived from DC volts and resistance measurements, respectively. For that reason, it is not necessary to independently verify the accuracy of temperature measurements. As long as the DC volts and resistance functions meet or exceed specifications, temperature function accuracy is automatically verified. However, temperature verification procedures are provided below for those who wish to separately verify temperature accuracy.

Thermocouple temperature

To verify the thermocouple temperature:

1. Connect the DC voltage calibrator output terminals and ice point reference to the 7700 CH1 H and L INPUT terminals using low-thermal shielded connections, as shown in the next figure.

Figure 14: Connections for 7700 thermocouple temperature verification

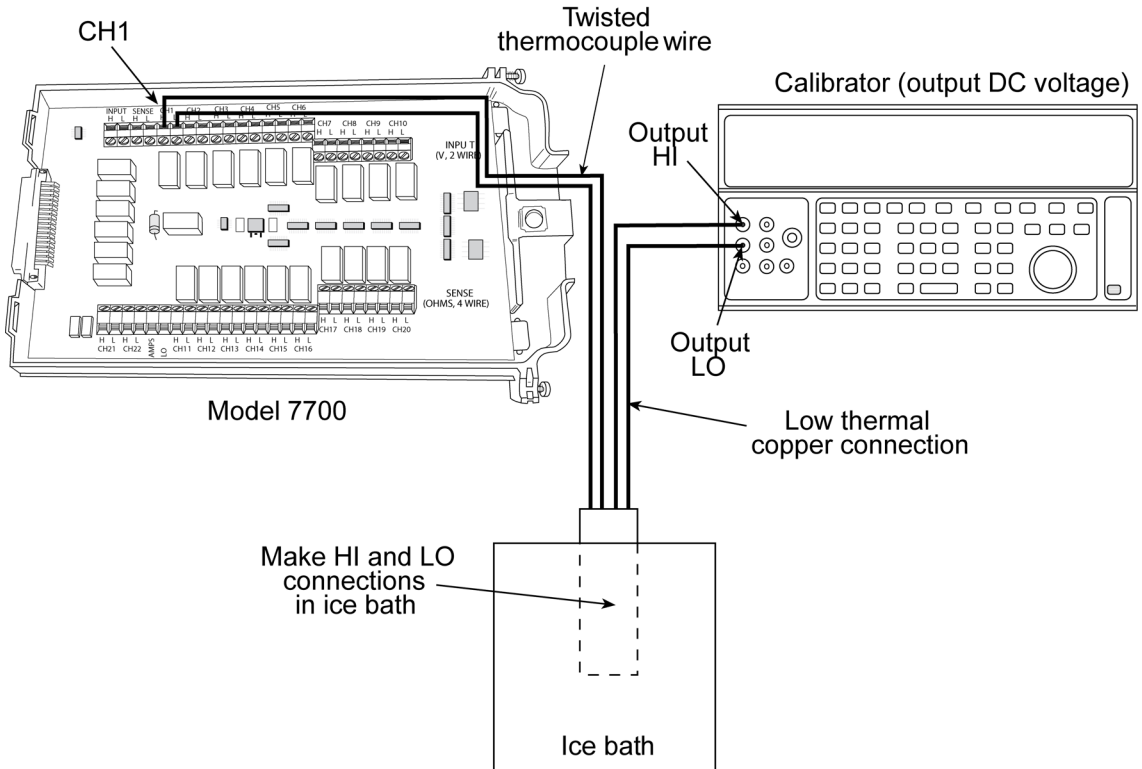

2. Install the 7700 in slot 1 of the 2701, then turn on the power and allow the unit to warm up for two hours before proceeding. Be sure the front panel INPUTS switch is set to the REAR position.
3. Select the temperature function by pressing the **TEMP** key. Close Channel 1 by pressing the **CLOSE** key and entering 101.
4. Configure the 2701 for °C units, type K temperature sensor, and internal reference junction as follows:
 - a. Press **SHIFT** then **SENSOR** and note the unit displays the temperature units: UNITS: C. If necessary, use the cursor and range keys to select °C units.
 - b. Press **ENTER**. The unit then displays the sensor type: SENS: TCOUPLE.
 - c. Make sure that TCOUPLE is displayed, then press **ENTER**. The unit displays the thermocouple type: TYPE: J.
 - d. Select a type K temperature sensor, then press **ENTER**. The unit then displays the reference junction type: JUNC: SIM.
 - e. Select INT reference junction, then press **ENTER**.
5. Source each of the voltages summarized in the next table and verify that the temperature readings are within limits. Be sure to select the appropriate thermocouple type for each group of readings. Open channel 1 after the test is complete.

Thermocouple type	Applied DC voltage*	Reading limits (1 year, 18 °C to 28 °C)
J	-7.659 mV 0 mV 42.280 mV	-191.0 °C to -189.0 °C -1.0 °C to +1.0 °C 749.0 °C to 751.0 °C
K	-5.730 mV 0 mV 54.138 mV	-191.0 °C to -189.0 °C -1.0 °C to +1.0 °C 1349.0 °C to 1351.0 °C

*Voltages shown are based on ITS-90 standard.

RTD temperature

To verify the RTD temperature:

1. Connect the precision decade resistance box to the 7700 CH1 and CH11 H and L terminals using four-wire connections.
2. Install the 7700 in slot 1 of the 2701, then turn on the power and allow the unit to warm up for two hours before proceeding. Be sure the front panel INPUTS switch is set to the REAR position.
3. Select the temperature function by pressing the **TEMP** key. Close channel 1 by pressing the **CLOSE** key and entering 101.
4. Configure the 2701 temperature function for °C units and RTD temperature sensor ($\alpha=0.00385$):
 - a. Press **SHIFT** then **SENSOR** and note the unit displays the temperature units: UNITS: C.
 - b. Press **ENTER** and note the unit displays the sensor type: SENS: TCOUPLE.
 - c. Using the cursor and range keys, set the display as follows: SENS: 4W-RTD.
 - d. Press **ENTER** and note the unit displays: TYPE: PT100.
 - e. Using the cursor and range keys, set the unit for the following display: TYPE: PT385.
 - f. Press **ENTER** to complete the temperature configuration process.
5. Set the decade resistance box to each of the values shown in the next table and verify that the temperature readings are within the required limits. Open channel 1 when finished.

Applied resistance*	Reading limits (1 year, 18 °C to 28 °C)
22.80 Ω	-190.06 °C to -189.94 °C
100.00 Ω	-0.06 °C to +0.06 °C
313.59 Ω	599.94 °C to 600.06 °C

*Based on $\alpha = 0.00385$. See text.

Verifying frequency

To verify the frequency function:

1. Connect the function generator to the 7700 CH1 H and L INPUT terminals.

Figure 15: Connections for 7700 frequency verification

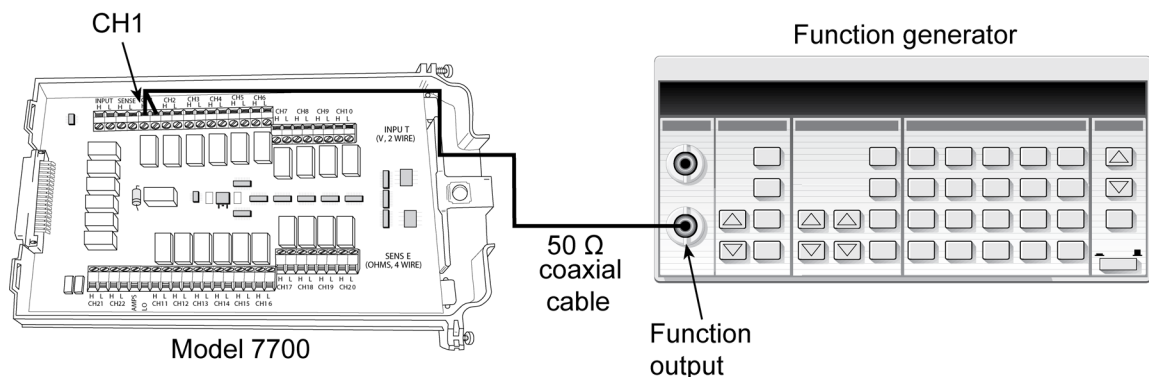

2. Install the 7700 in Slot 1 of the 2701, then turn on the power and allow the unit to warm up for one hour before proceeding. Be sure the front panel INPUTS switch is set to the REAR position.
3. Set the function generator to output a 1 kHz, 1 V RMS sine wave.
4. Select the 2701 frequency function by pressing the **FREQ** key. Close Channel 1 by pressing the **CLOSE** key and entering 101.
5. Verify that the 2701 is between 0.9999 kHz and 1.0001 kHz.

Verifying ratio and average

CAUTION

Exceeding 300 V between plug-in module INPUT or SENSE H and L terminals may cause instrument damage.

To verify ratio and average:

1. Connect the 7700 CH1 and CH11 H and L terminals to the DC voltage calibrator, as shown in the next figure.

Figure 16: Connections for Model 7700 ratio and average verification

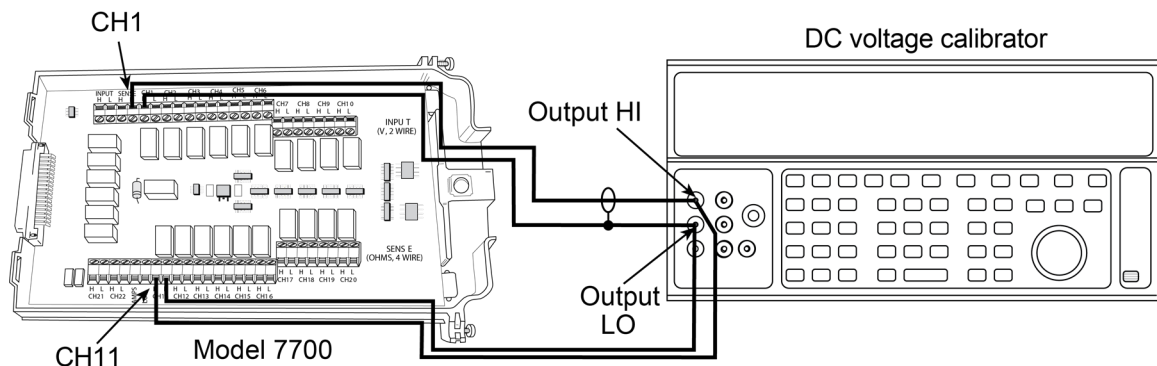

2. Install the 7700 in Slot 1 of the 2701, then turn on the power and allow the unit to warm up for two hours before proceeding. Be sure the front panel INPUTS switch is set to the REAR position.
3. Select the 2701 DCV function and the 1 V range. Close Channel 1 by pressing the **CLOSE** key and entering 101.
4. Select the 2701 RATIO function.
5. Set the calibrator output to 1.00000 VDC and allow the reading to settle.
6. Verify that the ratio reading is between 0.9999926 and 1.000074.
7. Press **OPEN** to open Channel 1.

In this section:

Introduction	2-1
Environmental conditions	2-1
Calibration considerations	2-3
Calibration code	2-3
Comprehensive calibration	2-4
Manufacturing calibration	2-18
Model 7700 calibration	2-21

Introduction

Use the procedures in this section to calibrate the 2701. Calibration procedures include:

- Comprehensive calibration: Usually the only calibration required in the field.
- Manufacturing calibration: Usually only performed at the factory (unless the unit has been repaired).
- 7700 calibration: Covers calibration procedures specific to 7700 cards.

WARNING

The information in this section is intended only for qualified service personnel. Do not attempt these procedures unless you are qualified.

All the procedures require accurate calibration equipment to supply precise DC and AC voltages, DC and AC currents, and resistance values. Comprehensive calibration can be performed any time by an operator either from the front panel or by using the SCPI commands sent either over the ethernet port or the RS-232 port. DC-only and AC-only calibration may be performed individually.

Environmental conditions

Conduct the calibration procedures in a location that has:

- An ambient temperature of 18 °C to 28 °C (65 °F to 82 °F).
- A relative humidity of less than 80% unless otherwise noted.

Warm-up period

Allow the 2701 Ethernet-Based DMM / Data Acquisition System to warm up for at least two hours before performing calibration.

If the instrument has been subjected to temperature extremes (those outside the ranges stated above), allow extra time for the instrument's internal temperature to stabilize. Typically, allow one extra hour to stabilize a unit that is 10 °C (18 °F) outside the specified temperature range.

Also, allow the test equipment to warm up for the minimum time specified by the manufacturer.

Line power

The 2701 requires a line voltage of 100V/120V/220V/240V \pm 10% and a line frequency of 45 Hz to 66 Hz or 360 Hz to 440 Hz. Note that the line frequency is automatically sensed at power-up, but the line voltage must be manually set to either 100 V/120 V or 220 V/240 V as described in [Setting the line voltage and replacing the line fuse](#) (on page 3-1).

Calibration considerations

When performing the calibration procedures:

- Make sure that the equipment is properly warmed up and connected to the appropriate input jacks. Also make sure that the correct front or rear terminals are selected with the INPUTS switch.
- Make sure the calibrator is in OPERATE before you complete each calibration step.
- Always let the source signal settle before calibrating each point.
- If an error occurs during calibration, the 2701 will generate an appropriate error message.

CAUTION

Observe the following safety precautions when performing these tests:

- **Some of the procedures in this section may expose you to dangerous voltages. Use standard safety precautions when such dangerous voltages are encountered to avoid personal injury or death caused by electric shock.**
 - **For the front panel terminals only, the maximum common-mode voltage (voltage between INPUT LO and chassis ground) is 500 V peak. Exceeding this value may cause a breakdown in insulation, creating a shock hazard.**
 - **For the plug-in modules, the maximum common-mode voltage (voltage between any plug-in module terminal and chassis ground) is 300 VDC or 300 VRMS. Exceeding this value may cause a breakdown in insulation, creating a shock hazard.**
 - **When using the front panel terminals simultaneously with plug-in modules, all cable insulation voltage ratings must equal or exceed the maximum voltage applied to either the front panel terminals or the plug-in module terminals.**
-

Calibration code

Before performing comprehensive calibration, unlock calibration by entering the appropriate calibration code.

Front panel calibration code

To enter or change the calibration code from the front panel:

1. Access the calibration menu by pressing **SHIFT** then **TEST**, then use the up or down range key to display `TEST: CALIB`. Press **ENTER** and note that the instrument displays `CAL: DATES`.
2. Use the up or down range key to scroll through the available calibration items until the unit displays `RUN`, then press **ENTER**.
3. You are prompted to enter a code. Use the left and right arrow keys to move among the digits; use the up range key to increment numbers and press the down range key to specify alphabetic letters.

NOTE

The default code is 002701.

4. Press **ENTER** to confirm the code.
5. The 2701 allows you to define a new calibration code. Use the up and down range keys to toggle between yes and no. Choose **N** if you do not want to change the code. Choose **Y** if you want to change the code. The unit then prompts you to enter a new code. Enter the code and press **ENTER**.

Remote calibration code

If you are performing calibration over the ethernet port or the RS-232 port, send this command to unlock calibration:

```
:CAL:PROT:CODE '<8-character string>'
```

The default code command is:

```
:CAL:PROT:CODE 'KI002701'
```

To change the code via remote, send the `:CAL:PROT:CODE` command twice; first with the present code and then with the new code.

Comprehensive calibration

The comprehensive calibration procedure calibrates the DCV, DCI, ACV, ACI, and ohms functions. You can also calibrate only the DCV/DCI and resistance or ACV/ACI functions.

These procedures are usually the only calibration required in the field. Manufacturing calibration is normally done only at the factory, but it should also be done in the field if the unit has been repaired. See [Manufacturing calibration](#) (on page 2-18) for more information.

Calibration cycle

Perform comprehensive calibration at least once a year or every 90 days to ensure that the unit meets the corresponding specifications.

Recommended equipment

The next table lists the recommended equipment you need for comprehensive, DC-only, and AC-only calibration procedures. You can use alternate equipment, such as a DC transfer standard and characterized resistors if that equipment has specifications at least as good as those listed.

Fluke 5700A Calibrator				
DC voltage	AC voltage (1 kHz, 50 kHz)*	DC current	AC current (1 kHz)	Resistance
10 V ±5 ppm 100 V ±7 ppm	10 mV ±710 ppm 100 mV ±200 ppm 1 V ±82 ppm 10 V ±82 ppm 100 V ±90 ppm 700 V ±85 ppm	10 mA ±60 ppm 100 mA ±70 ppm 1 A ±110 ppm	100 mA ±190 ppm 1 A ±690 ppm 2 A ±670 ppm	1 kΩ ±12 ppm 10 kΩ ±11 ppm 100 kΩ ±13 ppm 1 MΩ ±18 ppm
Miscellaneous equipment				
<ul style="list-style-type: none"> ▪ Keithley 8610 low-thermal shorting plug ▪ Double banana plug to double banana plug shielded cable ▪ BNC to double banana plug shielded cable 				

*1 kHz specifications. 10 mV and 700 V points require 1 kHz only. All calibrator specifications are 90-day, 23 °C ±5 °C specifications and indicate total absolute uncertainty at specified output.

Aborting calibration

You can abort the front panel calibration process at any time by pressing **EXIT**. The instrument will then ask you to confirm your decision to abort with the following message:

ABORT CAL?

Press **EXIT** to abort calibration at this point or press any other key to return to the calibration process.

NOTE

The 2701 will not respond to any remote programming commands while the `ABORT CAL?` message is displayed.

Front panel calibration

Perform the steps in the following paragraphs in the order shown for comprehensive, DC-only, and AC-only calibration procedures.

The procedures for front panel calibration include:

- Preparing the 2701 for calibration
- Front panel short and open calibration
- DC voltage calibration
- Resistance calibration
- DC current calibration
- AC voltage calibration
- AC current calibration
- Setting calibration dates and saving calibration

Preparing the Model 2701 for calibration

To prepare the 2701 for calibration:

1. Turn on the 2701 and allow it to warm up for at least two hours.
2. Start the calibration process:
 - a. Access the calibration menu by pressing **SHIFT** then **TEST**, then display TEST: CALIB using the up or down range key. Press **ENTER**.
 - b. Use the up or down range key to scroll through the available calibration menu items until the unit displays RUN, then press **ENTER**.
 - c. At the prompt, enter the calibration code. (The default code is 002701.) Use the left and right arrow keys to move among the digits; use the up range key to increment numbers and press the down range key to specify alphabetic letters. Confirm the code by pressing **ENTER**.
 - d. Choose **N** at the prompt to proceed without changing the code, then press **ENTER**.
3. Select a calibration test from the next table. Use the up and down range keys to scroll through the options and press **ENTER** to select a test.

Procedure	Menu selection	Procedures
Full calibration	ALL	All comprehensive calibration steps (DC and AC)
DCV, DCI, and ohms	DC	DC voltage, DC current, and resistance calibration
ACV and ACI	AC	AC voltage and AC current calibration

Front panel short and open calibration

At the 2701 prompt for a front panel short, perform the following:

1. Connect the 8610 low-thermal short to the instrument front panel INPUT and SENSE terminals as shown in the next figure. Make sure the INPUTS button is not pressed in so that the front inputs are selected. Wait at least three minutes before proceeding to allow for thermal equilibrium.

Figure 17: Low-thermal short connections

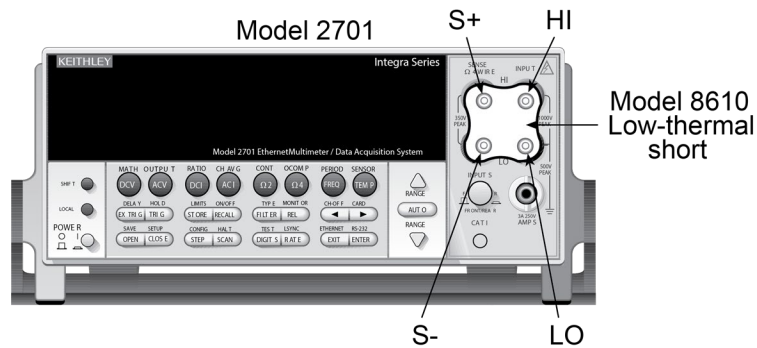

NOTE

Be sure to connect the low-thermal short properly to the HI, LO, and SENSE terminals. Keep drafts away from low-thermal connections to avoid thermal drift, which could affect calibration accuracy.

2. Press ENTER to start short-circuit calibration. The unit will display CALIBRATING.
3. When the unit is finished with short-circuit calibration, it will display OPEN CIRCUIT.
4. Remove the calibration short and press **ENTER**. During this phase, the CALIBRATING message will be displayed.

NOTE

Be sure to minimize movement near front Input terminals. Excessive movements can cause capacitive coupling errors.

DC voltage calibration

After the front panel short and open calibration procedure, you will be prompted for the first DC voltage.

To perform DC voltage calibration:

1. Connect the calibrator to the 2701 as shown in the next figure. Allow three minutes for thermal equilibrium.

Figure 18: Connections for DC volts and ohms calibration

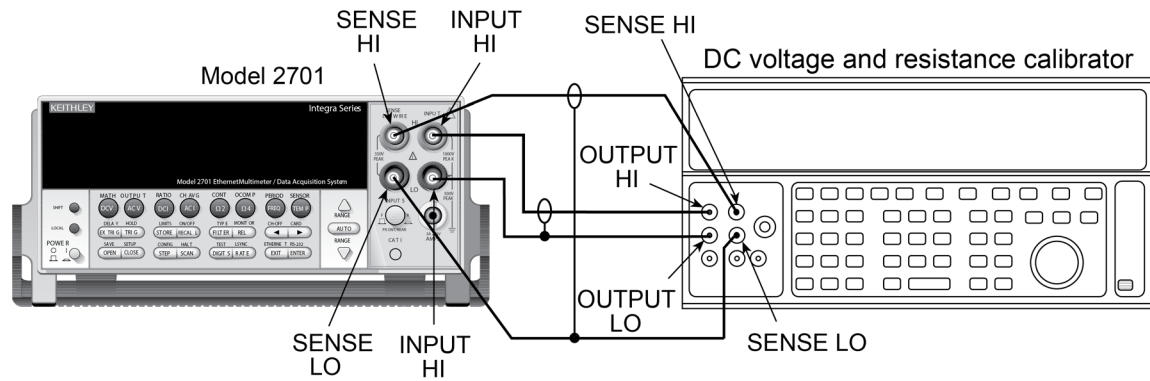

NOTE

Although 4-wire connections are shown, the sense leads are connected and disconnected at various points in this procedure by turning calibrator external sense on or off as appropriate. If your calibrator does not have provisions for turning external sense on and off, disconnect the sense leads when external sensing is to be turned off and connect the sense leads when external sensing is to be turned on.

2. Set the calibrator to output DC volts and turn off external sense.
3. Perform the steps listed in the next table to complete DC volts calibration. For each calibration step:
 - a. Set the calibrator to the indicated value and make sure it is in OPERATE.
 - b. Press **ENTER** to calibrate that step.
 - c. Wait until the 2701 finishes each step. The unit will display CALIBRATING while calibrating.

NOTE

If your calibrator cannot output the values recommended in the next table, use the left and right arrow keys and the up and down range keys to set the 2701 display value to match the calibrator output voltage.

Calibration step	Calibrator voltage	Allowable range
+10 V	+10.00000 V	+9 V to +11 V
-10 V	-10.00000 V	-9 V to -11 V
100 V	+100.0000 V	90 V to 110 V

Resistance calibration

Completing the 100 VDC calibration step ends the DC voltage calibration procedure. The 2701 will then prompt you to connect 1k Ω .

To perform resistance calibration:

1. Set the calibrator output for resistance and turn on external sense.

NOTE

Use external sense (4-wire ohms) when calibrating all resistance ranges. Be sure that the calibrator external sense mode is turned on.

2. Perform the calibration steps summarized in the next table. For each step:
 - a. Set the calibrator to the indicated value and place the unit in operate. (If the calibrator cannot output the exact resistance value, use the 2701 left and right arrow keys and the range keys to adjust the display to agree with the actual calibrator resistance.
 - b. Press the **ENTER** key to calibrate each point.
 - c. Wait for the 2701 to complete each step before proceeding.

Calibration step	Calibrator resistance*	Allowable range
1 k Ω	1 k Ω	0.9 Ω to 1.1 k Ω
10 k Ω	10 k Ω	9 k Ω to 11 k Ω
100 k Ω	100 k Ω	90 k Ω to 110 k Ω
1 M Ω	1 M Ω	0.9 M Ω to 1.1 M Ω

*Nominal resistance. Adjust the calibration parameters to agree with actual value.

DC current calibration

To perform DC current calibration:

1. Connect the calibrator to the AMPS and INPUT LO terminals of the 2701 as shown in the next figure.

Figure 19: Connections for DC and AC current calibration

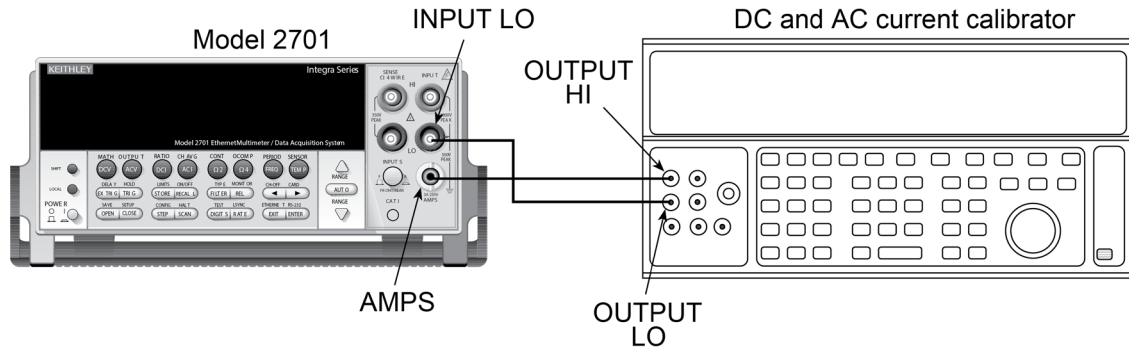

2. Calibrate each current step summarized in the next table. For each step:
 - a. Set the calibrator to the indicated current and make sure the unit is in operate. Use the recommended current, if possible.
 - b. Send the indicated programming command. Change the current parameter if you are using a different calibration current.
 - c. Wait until the 2701 completes each step before proceeding.

NOTE

If you are performing DC-only calibration, see [Setting calibration dates and saving calibration](#) (on page 2-12).

Calibration step	Calibrator current	Allowable range
10 mA	10.00000 mA	9 mA to 11 mA
100 mA	100.0000 mA	90 mA to 110 mA
1 A	1.000000 A	0.9 A to 1.1 A

AC voltage calibration

To perform AC voltage calibration:

1. Connect the calibrator to the 2701 INPUT HI and LO terminals as shown in the next figure.

Figure 20: Connections for AC voltage calibration

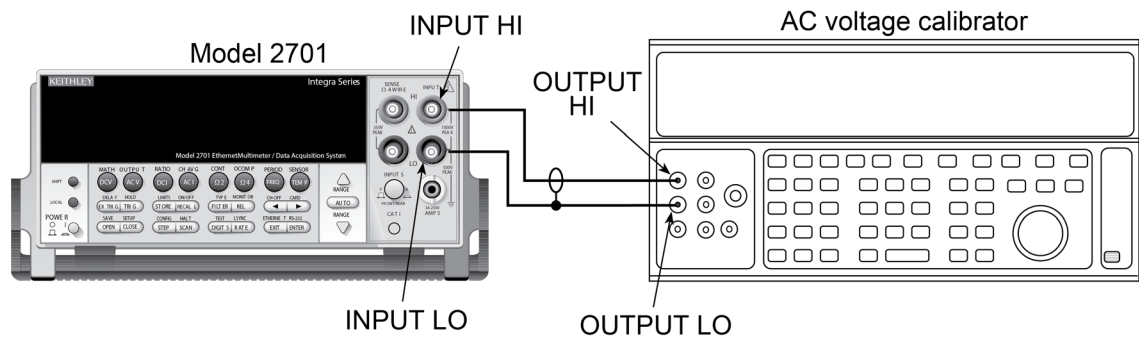

2. Perform the calibration steps summarized in the next table. For each step:
 - a. Set the calibrator to the indicated value and make sure the calibrator is in OPERATE.
 - b. Press **ENTER** to complete each operation.
 - c. Wait until the 2701 completes each step before proceeding.

Calibration step	Calibrator voltage, frequency
10 mV AC at 1 kHz	10.00000 mV, 1 kHz
100 mV AC at 1 kHz	100.0000 mV, 1 kHz
100 mV AC at 50 kHz	100.0000 mV, 50 kHz
1 VAC at 1 kHz	1.000000 V, 1 kHz
1 VAC at 50 kHz	1.000000 V, 50 kHz
10 VAC at 1 kHz	10.00000 V, 1 kHz
10 VAC at 50 kHz	10.00000 V, 50 kHz
100 VAC at 1 kHz	100.0000 V, 1 kHz
100 VAC at 50 kHz	100.0000 V, 50 kHz
700 VAC at 1 kHz	700.000 V, 1 kHz

AC current calibration

After the 700 VAC at 1 kHz point has been calibrated, the unit will prompt you for 100 mA at 1 kHz.

To perform AC current calibration:

1. Connect the calibrator to the AMPS and INPUT LO terminals of the 2701 as shown in [DC current calibration](#) (on page 2-10).
2. Perform the calibration steps summarized in the next figure.
 - a. Set the calibrator to the indicated current and frequency, make sure the unit is in OPERATE.
 - b. Press **ENTER** to complete each calibration step.
 - c. Allow the unit to complete each step before proceeding.

Calibration step	Calibrator current, frequency
100 mA at 1 kHz	100.0000 mA, 1 kHz
1 A at 1 kHz	1.000000 A, 1 kHz
2 A at 1 kHz	2.000000 A, 1 kHz

Setting calibration dates and saving calibration

At the end of the calibration procedure, the instrument will display the CALIBRATION COMPLETE message. Press **ENTER** to continue and the 2701 will prompt you to enter the calibration date and the calibration due date. Set these dates as follows:

1. At the `CAL DATE:` prompt, use the left and right arrow keys and the range keys to set the calibration date, then press **ENTER**.
2. The unit will then prompt you to enter the next calibration due date with this prompt:
`CAL NDUE:.` Use the left and right arrow keys and the range keys to set the calibration due date, then press **ENTER**.
3. The unit will prompt you to save new calibration constants with this message:
`SAVE CAL? YES.` To save the new constants, press **ENTER**. If you do not want to save the new constants, press the down range key to toggle to `NO`, then press **ENTER**.

NOTE

Calibration constants calculated during the present calibration procedure will not be saved unless you choose the YES option. Previous calibration constants will be retained if you select NO.

Remote calibration

Follow the steps in this section to perform comprehensive procedures via remote. See the [Calibration reference](#) (on page 8-1) for a detailed list and description of remote calibration commands.

When sending calibration commands, be sure that the 2701 completes each step before sending the next command. You can do so either by observing the front panel CALIBRATING message or by detecting the completion of each step via remote.

The procedures for calibrating the 2701 via remote include:

- Preparing the 2701 for calibration
- Short and open calibration
- DC voltage calibration
- Resistance calibration
- DC current calibration
- AC voltage calibration
- AC current calibration
- Programming calibration dates
- Saving calibration constants
- Locking out calibration

NOTE

As with front panel calibration, you can choose to perform comprehensive, DC-only, or AC-only calibration. Be sure to include a space character between each command and parameter.

Preparing the Model 2701 for calibration

To prepare the 2701 for calibration:

1. Connect the 2701 to the ethernet or connect the unit to a computer through the RS-232 port.
2. Turn on the 2701 and allow it to warm up for at least two hours before performing calibration.
3. Unlock the calibration function by sending `:CAL:PROT:CODE 'KI002701'`.

NOTE

The above command shows the default code, KI002701.

4. Send `:CAL:PROT:INIT` to initiate calibration.

Short and open calibration

To perform short and open calibration:

1. Connect the 8610 low-thermal short to the instrument INPUT and SENSE terminals. Make sure the INPUTS button is not pressed in so that the front inputs are active. Wait at least three minutes before proceeding to allow for thermal equilibrium.

NOTE

Be sure to connect the low-thermal short properly to the HI, LO, and SENSE terminals. Keep drafts away from low-thermal connections to avoid thermal drift, which could affect calibration accuracy.

2. Send the `:CAL:PROT:DC:STEP1` command.
3. After the 2701 completes this step, remove the low-thermal short and then send the `:CAL:PROT:DC:STEP2` command.

NOTE

Be sure to minimize movement near front Input terminals. Excessive movements can cause capacitive coupling errors.

DC voltage calibration

After the front panel short and open steps, perform the following DC voltage calibration steps:

1. Connect the calibrator to the 2701. Allow three minutes or thermal equilibrium.

NOTE

Although 4-wire connections are shown, the sense leads are connected and disconnected at various points in this procedure by turning calibrator external sense on or off as appropriate. If your calibrator does not have provisions for turning external sense on and off, disconnect the sense leads when external sensing is to be turned off and connect the sense leads when external sensing is to be turned on.

2. Perform the calibration steps summarized in the next table. For each step:
 - a. Set the calibrator to the indicated voltage and make sure the unit is in operate. Use the recommended voltage, if possible.
 - b. Send the indicated programming command. Change the voltage parameter if you are using a different calibration voltage.
 - c. Wait until the 2701 completes each step before proceeding.

NOTE

Make sure that the calibrator has settled to the final value. You can do this by verifying that the Settled indicator is off or by using the *OPC? (operation complete) query.

Calibration step	Calibrator voltage	Calibration command*	Parameter range
+10 V	+10.00000 V	:CAL:PROT:DC:STEP3 10	9 to 11
-10 V	-10.00000 V	:CAL:PROT:DC:STEP4 -10	-9 to -11
100 V	100.0000 V	:CAL:PROT:DC:STEP5 100	90 to 110

*Use recommended value where possible. Change parameter accordingly if using a different calibrator voltage.

Resistance calibration

To perform resistance calibration:

1. Set the calibrator output for resistance and turn on external sense.

NOTE

Use external sense (4-wire ohms) when calibrating all resistance ranges. Be sure that the calibrator external sense mode is turned on.

2. Perform the calibration steps summarized in the next table. For each step:
 - a. Set the calibrator to the indicated value and place the unit in operate. Use the recommended resistance or the closest available value.
 - b. Send the indicated programming command. Change the command parameter if you are using a different calibration resistance than that shown.
 - c. Wait for the 2701 to complete each step before proceeding.

Calibration step	Calibrator resistance	Calibration command*	Parameter range
1 k Ω	1 k Ω	:CAL:PROT:DC:STEP6 1E3	900 to 1.1E3
10 k Ω	10 k Ω	:CAL:PROT:DC:STEP7 10E3	9E3 to 11E3
100 k Ω	100 k Ω	:CAL:PROT:DC:STEP8 100E3	90E3 to 110E3
1 M Ω	1 M Ω	:CAL:PROT:DC:STEP9 1E6	900E3 to 1.1E6

*Nominal resistance. Adjust the calibration parameters to agree with actual value.

DC current calibration

To perform DC current calibration:

1. Connect the calibrator to the AMPS and INPUT LO terminals of the 2701 as shown in [DC current calibration](#) (on page 2-10).
2. Perform the calibration steps listed in the next table. For each step:
 - a. Set the calibrator to the indicated current and make sure the unit is in OPERATE. Use the recommended current, if possible.
 - b. Send the indicated programming command. Change the current parameter if you are using a different calibration current.
 - c. Wait until the 2701 completes each step before proceeding.

NOTE

If you are performing DC-only calibration, see [Programming calibration dates](#) (on page 2-18).

Calibration step	Calibrator current	Calibration command*	Parameter range
10mA	10.00000mA	:CAL:PROT:DC:STEP10 10E-3	9E-3 to 11E-3
100mA	100.00000mA	:CAL:PROT:DC:STEP11 100E-3	90E-3 to 110E-3
1A	1.000000A	:CAL:PROT:DC:STEP12 1	0.9 to 1.1

*Change parameter if using different current.

AC voltage calibration

To perform AC voltage calibration:

1. Connect the calibrator to the 2701 INPUT HI and LO terminals as shown in [AC voltage calibration](#) (on page 2-17).
2. Perform the calibration steps summarized in the next table. For each step:
 - a. Set the calibrator to the indicated voltage and frequency and make sure the unit is in OPERATE. You must use the stated voltage and frequency.
 - b. Send the indicated programming command.
 - c. Wait until the 2701 completes each step before proceeding.

Calibration step	Calibrator voltage, frequency	Calibration command
10 mVAC at 1 kHz	10.00000 mV, 1 kHz	:CAL:PROT:AC:STEP1
100 mVAC at 1 kHz	100.0000 mV, 1 kHz	:CAL:PROT:AC:STEP2
100 mVAC at 50 kHz	100.0000 mV, 50 kHz	:CAL:PROT:AC:STEP3
1 VAC at 1 kHz	1.000000 V, 1 kHz	:CAL:PROT:AC:STEP4
1 VAC at 50 kHz	1.000000 V, 50 kHz	:CAL:PROT:AC:STEP5
10 VAC at 1 kHz	10.00000 V, 1 kHz	:CAL:PROT:AC:STEP6
10 VAC at 50 kHz	10.00000 V, 50 kHz	:CAL:PROT:AC:STEP7
100 VAC at 1 kHz	100.0000 V, 1 kHz	:CAL:PROT:AC:STEP8
100 VAC at 50 kHz	100.0000 V, 50 kHz	:CAL:PROT:AC:STEP9
700 VAC at 1 kHz	700.000 V, 1 kHz	:CAL:PROT:AC:STEP10

AC current calibration

To perform AC current calibration:

1. Connect the calibrator to the AMPS and INPUT LO terminals of the 2701 as shown in [DC voltage calibration](#) (on page 2-8).
2. Perform the calibration steps summarized in the next table. For each step:
 - a. Set the calibrator to the indicated current and frequency, make sure the unit is in operate. You must use the stated current and frequency.
 - b. Send the indicated programming command.
 - c. Wait until the 2701 completes each step before proceeding.

Calibration step	Calibrator current, frequency	Calibration command
100 mA at 1 kHz	100.0000 mA, 1 kHz	:CAL:PROT:AC:STEP11
1 A at 1 kHz	1.000000 A, 1 kHz	:CAL:PROT:AC:STEP12
2 A at 1 kHz	2.000000 A, 1 kHz	:CAL:PROT:AC:STEP13

Programming calibration dates

Program the present calibration date and calibration due date by sending the following commands:

```
:CAL:PROT:DATE <year>, <month>, <day>
```

```
:CAL:PROT:NDUE <year>, <month>, <day>
```

For example, the following commands assume calibration dates of 12/15/1999 and 12/15/2000 respectively:

```
:CAL:PROT:DATE 1999, 12, 15
```

```
:CAL:PROT:NDUE 2000, 12, 15
```

Saving calibration constants

After completing the calibration procedure, send the following command to save the new calibration constants:

```
:CAL:PROT:SAVE
```

NOTE

Calibration constants will not be saved unless you send the `:CAL:PROT:SAVE` command.

Locking out calibration

After saving calibration, send the `:CAL:PROT:LOCK` command to lock out calibration.

Manufacturing calibration

The manufacturing calibration procedure is normally performed only at the factory, but the necessary steps are included here in case the unit is repaired and the unit requires these calibration procedures.

NOTE

If the unit has been repaired, the comprehensive calibration procedure should also be performed in addition to the manufacturing calibration procedure.

Recommended test equipment

The next table summarizes the test equipment required for the manufacturing calibration steps. In addition, you will need a calibrator and a signal generator to complete the comprehensive calibration steps.

Stanford Research Systems DS345 Function Generator <ul style="list-style-type: none">▪ 1 V RMS, 3 Hz, ± 5 ppm▪ 1 V RMS, 1 kHz, ± 5 ppm
Keithley Instruments 2001 or 2002 Digital Multimeter <ul style="list-style-type: none">▪ 1 V, 3 Hz AC, $\pm 0.13\%$
Keithley Instruments 7797 Calibration System

Calibration card preparation

Before performing manufacturing calibration, short the HI, LO, SHI, and SLO terminals of TE100 on the 7797 Calibration System card together using the supplied jumpers. These connections will form a low-thermal short necessary for the manufacturing calibration procedure. The 7797 should then be installed in scanner slot 1.

Unlocking manufacturing calibration

To unlock manufacturing calibration, press and hold the OPEN key while turning on the power.

Measuring function generator signal amplitude

The 3 Hz function generator signal amplitude must be accurately measured using the digital multimeter listed in [Recommended test equipment](#) (on page 2-19).

To measure function generator signal amplitude:

1. Connect the function generator output to the digital multimeter INPUT jacks.
2. Turn on the function generator and multimeter and allow a two-hour warm-up period before measuring.
3. Set the function generator to output a 1 V RMS sine wave at 3 Hz.
4. Measure and record the signal amplitude.

Front panel manufacturing calibration

To perform manufacturing calibration from the front panel:

1. Install the shorted 7797 calibration board (see [Calibration card preparation](#) (on page 2-19)) in scanner card slot 1 and select the rear inputs with the INPUTS switch. Allow three minutes for thermal equilibrium.
2. Press and hold the **OPEN** key while turning on the power.
3. Press **SHIFT** then **TEST**, then display CALIB: TEST with the up or down range key.
4. Press **ENTER**, select RUN, then enter the appropriate calibration code (default: 002701).
5. Select **ALL** at the CAL:RUN prompt.
6. Press **ENTER** to perform the first manufacturing calibration step.
7. Perform the entire front panel comprehensive calibration procedure discussed earlier in this section. See [Comprehensive calibration](#) (on page 2-4).
8. Connect the function generator to the 2701 front panel INPUT jacks as shown in the next figure. Select the front input jacks with the INPUTS switch.

Figure 21: Function generator connections for manufacturing calibration

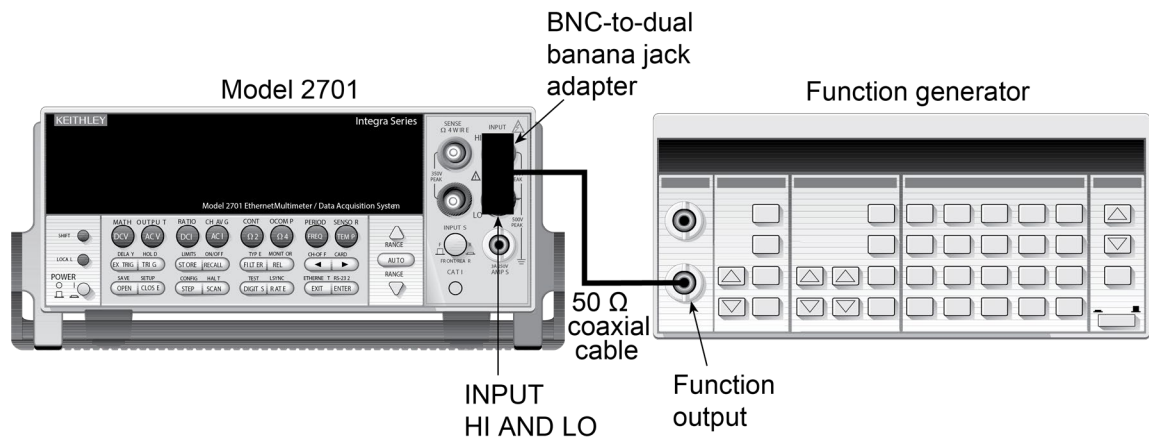

9. After the last AC current calibration step, the instrument will prompt you to enter 3 Hz at 1 V RMS and 1 kHz with the following prompts:
 - **Low-frequency cal** — Set the function generator to output a 1 V RMS, 3 Hz sine wave. Use the left and right arrow keys and the range keys to adjust the display to agree with the generator amplitude you measured previously, then press **ENTER**.
 - **Frequency cal** — Set the function generator to output a 1 V RMS, 1 kHz sine wave. Enter 1.000000 kHz at the prompt, then press **ENTER**.
10. Set the calibration dates, then save calibration to complete the process.

Remote manufacturing calibration

To perform remote manufacturing calibration:

1. Install the shorted 7797 calibration board (see [Calibration card preparation](#) (on page 2-19)) into scanner card slot 1 and select the rear inputs with the INPUTS switch. Allow three minutes for thermal equilibrium.
2. Press and hold the **OPEN** key while turning on the power.
3. Enable calibration by sending the :CODE command. The default command is :CAL:PROT:CODE 'KI002701'.
4. Initiate calibration by sending the :CAL:PROT:INIT command.
5. Calibrate step 0 with the :CAL:PROT:DC:STEP0 command.
6. Perform the remote comprehensive calibration procedure discussed earlier in this section. See [Comprehensive calibration](#) (on page 2-4).
7. Connect the function generator to the 2701 INPUT jacks. Select the front input jacks with the INPUTS switch.
8. Set the generator to output a 1 V RMS, 3 Hz sine wave, then send :CAL:PROT:AC:STEP14 <Cal_voltage>. <Cal_voltage> is the actual 3 Hz generator signal amplitude you previously measured.
9. Set the generator to output a 1 V RMS, 1 kHz sine wave, then send :CAL:PROT:AC:STEP15 1E3.
10. Send the following commands to set calibration dates, save calibration, and lock out calibration:
:CAL:PROT:DATE <year>, <month>, <day>
:CAL:PROT:NDUE <year>, <month>, <day>
:CAL:PROT:SAVE
:CAL:PROT:LOCK

Model 7700 calibration

The following procedures calibrate the temperature sensors on the 7700 plug-in models.

NOTE

For additional information about the Keithley modules, refer to the appropriate appendix in the *2701 User's Manual*.

Recommended test equipment

To calibrate the 7700, you will need the equipment summarized in the next table.

Digital Thermometer ■ 18 °C to 28 °C, ±0.1 °C
Keithley 7797 Calibration System

Calibration card connections

The 7700 being calibrated should be connected to the 7797 Calibration System card and the card should then be installed in scanner slot 1. Note that the module being calibrated will be external to the 2701 to avoid card heating during calibration.

Model 7700 calibration

NOTE

Before calibrating the 7700, make sure that power has been removed from the card for at least two hours to allow the card circuitry to cool down. After turning on the power during the calibration procedure, complete the procedure as quickly as possible to minimize card heating that could affect calibration accuracy. Allow the 2701 to warm up for at least two hours.

Front panel Model 7700 calibration

To calibrate the 7700 from the front panel:

1. Connect the 7700 to the 7797 Calibration System card (see [Calibration card connections](#) (on page 2-22)).
2. With the power off, install the 7700/7797 combination in slot 1 and select the rear inputs with the INPUTS switch. Allow three minutes for thermal equilibrium.
3. Accurately measure and record the cold temperature of the 7700 card surface at the center of the card with an RTD sensor.
4. Press and hold the 2701 **OPEN** key while turning on the power.
5. Press **SHIFT** then **TEST**, then display `TEST:CALIB` with the up or down range key. Press **ENTER**, select `RUN`, then enter the appropriate calibration code. The default code is `002701`.
6. Using the up or down range key, select `CARD` at the `CAL:RUN` prompt, then press **ENTER**.
7. Set the display value to the cold calibration temperature (°C) you measured in step 3, then press **ENTER** to complete calibration.

Remote Model 7700 calibration

To remotely calibrate the 7700:

1. Connect the 7700 to the 7797 Calibration System card (see [Calibration card connections](#) (on page 2-22)).
2. With the power off, install the 7700/7797 combination in slot 1 and select the rear inputs with the INPUTS switch. Allow three minutes for thermal equilibrium.
3. Accurately measure and record the cold temperature of the 7700 card surface at the center of the card.
4. Press and hold the 2701 OPEN key while turning on the power.
5. Enable calibration by sending the :CODE command. The default command is :CAL:PROT:CODE 'KI002701'.
6. Initiate calibration by sending :CAL:PROT:CARD1:INIT.
7. Calibrate the 7700 by sending :CAL:PROT:CARD1:STEP0 <temp>. <temp> is the cold calibration temperature (°C) measured in step 3.
8. Send the following commands to save calibration and lock out calibration:
:CAL:PROT:CARD1:SAVE
:CAL:PROT:CARD1:LOCK

Routine maintenance

In this section:

Introduction	3-1
Setting the line voltage and replacing the line fuse	3-1
Replacing the front terminal AMPS fuse	3-4
Replacing Model 7700 plug-in module amps fuses	3-5
Replacing non-volatile RAM battery	3-6
Plug-in module relay closure count	3-7

Introduction

The information in this section deals with routine maintenance and includes procedures for setting the line voltage, replacing the 2701 line and front terminal AMPS fuses, and replacing the amps fuses for the 7700 plug-in module. Replacement of the 2701 non-volatile RAM battery and module relay closure count is also covered.

Setting the line voltage and replacing the line fuse

WARNING

Disconnect the line cord at the rear panel and remove all front and rear test leads connected to the instrument before replacing the line fuse.

The power line fuse is located in the power module next to the AC power receptacle. See the next figure.

Figure 22: Power module

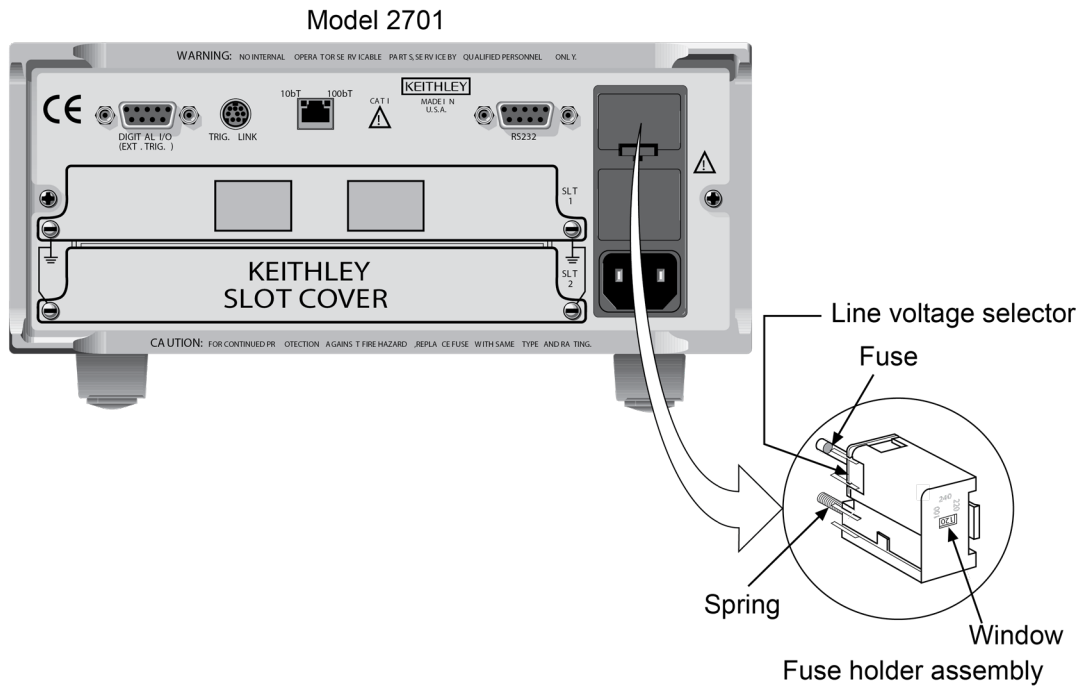

To change the line voltage or replace the line fuse:

1. Place the tip of a flat-blade screwdriver into the power module by the fuse holder assembly. Gently push in and to the left. Release pressure on the assembly and its internal spring will push it out of the power module.
2. Remove the fuse and replace it with the type listed in the next table.

CAUTION

For continued protection against fire or instrument damage, replace the fuse only with the type and rating listed. If the instrument repeatedly blows fuses, locate and correct the cause of the trouble before replacing the fuse.

3. If configuring the instrument for a different line voltage, remove the line voltage selector from the assembly and rotate it to the proper position. When the selector is installed into the fuse holder assembly, the correct line voltage appears inverted in the window.

CAUTION

Operating the 2701 with the wrong line voltage selected may result in instrument damage.

4. Install the fuse holder assembly into the power module by pushing it in until it locks in place.

Line Voltage	Rating	Keithley Part Number
100/120 V	0.630 A, 250 V, 5 × 20 mm, slow-blow	FU-106-.630
200/240 V	0.315 A, 250 V, 5 × 20 mm, slow-blow	FU-106-.315

Replacing the front terminal AMPS fuse

The front terminal AMPS fuse protects the 2701 current input from an over-current condition. Follow the steps below to replace the AMPS fuse.

⚠ WARNING

Make sure the instrument is disconnected from the power line and other equipment before replacing the AMPS fuse.

Figure 23: Front terminal AMPS fuse

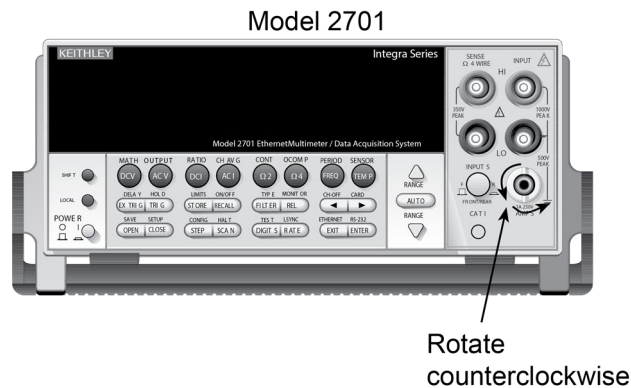

To replace the front terminal AMPS fuse:

1. Turn off the power and disconnect the power line and test leads.
2. From the front panel, gently push in the AMPS jack with your thumb and rotate the fuse carrier one-quarter turn counterclockwise. Release pressure on the jack and its internal spring will push the fuse carrier out of the socket.
3. Remove the fuse and replace it with the same type: 3 A, 250 V, fast-blow, Keithley part number FU-99-1.

CAUTION

Do not use a fuse with a higher current rating than specified or instrument damage may occur. If the instrument repeatedly blows fuses, locate and correct the cause of the trouble before replacing the fuse.

4. Install the new fuse by reversing the above procedure.

Replacing Model 7700 plug-in module amps fuses

⚠ WARNING

The information in this section is intended only for qualified service personnel. Do not perform these procedures unless you are qualified.

Figure 24: 7700 amps fuses

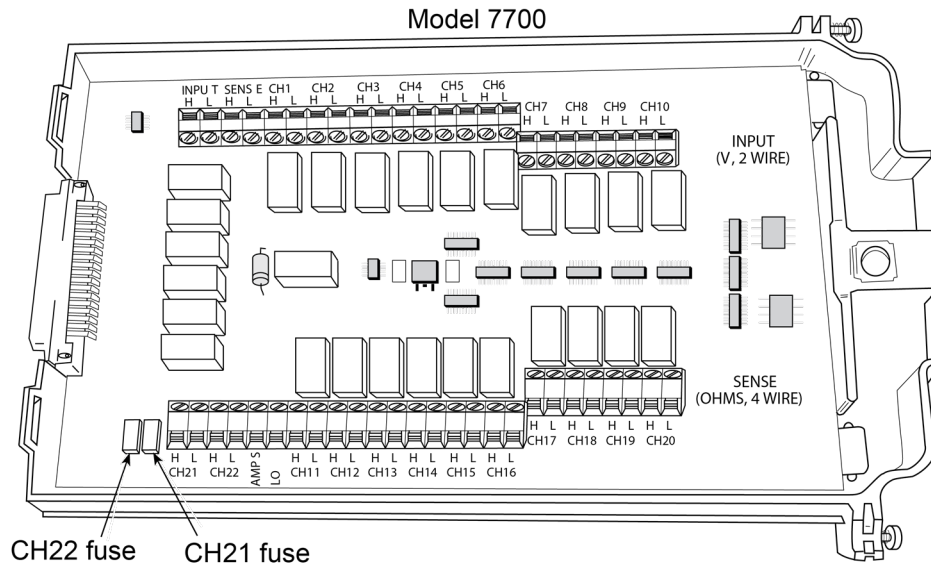

Make sure that all plug-in module connections are de-energized and disconnected before replacing module amps fuses.

To replace the 7700 plug-in module amps fuses:

1. Turn off the power and disconnect the power line and external connections from the 7700.
2. Open the 7700 top cover.
3. Locate the amps fuses for CH21 and CH22.
4. Remove the circuit board from the bottom plastic housing by removing the two bottom screws.
5. De-solder the blown CH21 or CH22 fuse as required, taking care not to damage the circuit board or spread solder flux around the board.
6. Install a new 3 A, 250 V fast-blow fuse, Keithley part number FU-107-1.

CAUTION

Do not use a fuse with a higher current rating than specified or module damage may occur.

7. Solder the new fuse in place using organic (OA based) flux solder, again taking care not to damage the circuit board or spread solder flux around the board.
8. Carefully clean the repaired area of the circuit board with a foam tipped swab or brush dipped in pure water, then blow dry the board with dry nitrogen gas. Allow the board to dry for several hours in a 50 °C low-humidity environment before use.
9. Re-install the circuit board into the plastic housing, then close the top cover.

Replacing non-volatile RAM battery

The 2701 has a rechargeable lithium ion battery for non-volatile RAM. Use the procedure below to replace the battery, if required. Refer to [Disassembly](#) (on page 5-1) and the component layout drawings in for more information.

WARNING

There is a danger of explosion if the battery is incorrectly replaced. Replace only with the part designated by the corresponding Keithley Instruments part number. Dispose of used batteries according to the manufacturer's instructions.

The following procedure is intended only for qualified service personnel. Do not perform this procedure unless you are qualified.

Disconnect the line cord and all connecting wires from the 2701 before removing the top cover.

WARNING

The precautions below must be followed to avoid personal injury.

- Wear safety glasses or goggles when working with lithium ion batteries.
- Do not short the battery terminals together.
- Keep lithium ion batteries away from all liquids.
- Observe proper polarity when installing the battery.
- Do not incinerate or otherwise expose the battery to excessive heat (> 60 °C).
- Bulk quantities of lithium ion batteries should be disposed of as hazardous waste.

To replace the RAM battery:

1. Before replacing the battery, refer to the troubleshooting procedures in [Troubleshooting](#) (on page 4-1) to determine if the battery requires replacement
2. Remove the 2701 top cover and motherboard using the disassembly procedures in [Disassembly](#) (on page 5-1).
3. Remove the battery from its holder on the bottom of the case near the front panel.
4. Install a new battery.
5. Re-install the motherboard and top cover by following the disassembly procedures in [Disassembly](#) (on page 5-1) in reverse order. Be sure to plug in all cables, including the cable that connects the battery to the motherboard at J900.

Plug-in module relay closure count

The 2701 keeps an internal count of the number of times each module relay has been closed. This count will help you determine if and when any relays require replacement (see module contact life specifications). The count can be read or reset only via remote as outlined below.

Closure count commands

The following table summarizes closure count commands.

Command	Description
<pre>:ROUTE :CLOSE :COUNT? (@clist) :INTERval < NRf> :INTERval? :RCOUNT (@clist)</pre>	<p>Route subsystem. Path to CLOSE commands.</p> <p>Query count for channels in <code>clist</code> (channel list). Set count update interval in minutes (1 to 1440). Query count update interval. Reset count for channels in <code>clist</code>.*</p>

* Unit must be in manufacturing calibration mode.

Reading relay closure count

To determine the closure count of specific channels, send this query using remote communications:

```
:ROUTe:CLOSe:COUNT? (@clist)
```

Here, `clist` is the summary of channels. For example, to determine the closure count of channels 1 and 4 of a module in slot 1, the following query would be sent:

```
:ROUT:CLOS:COUN? (@101,104)
```

The following query would determine the closure count of slot 1 module channels 1 through 10:

```
:ROUT:CLOS:COUN? (@101:110)
```

Resetting relay closure count

NOTE

The 2701 must be in the manufacturing calibration mode to reset the closure count. To do so, press and hold the OPEN key while turning on the power, then send the `:CAL:PROT:CODE` code to unlock calibration (KI002701). After resetting relay counts, send `:CAL:PROT:LOCK` to lock out calibration.

To reset the relay closure count of specific channels to 0, send this command using remote communications:

```
:ROUTe:CLOSe:RCOunt (@clist)
```

`clist` is the summary of channels to be reset. For example, the following command resets channels 2 and 7 of a module in slot 1 to 0:

```
:ROUT:CLOS:RCO (@102,107)
```

The following command resets the count of slot 1 module channels 1 through 10:

```
:ROUT:CLOS:RCO (@101:110)
```

Setting count update interval

Relay closure counts are updated in temporary RAM every time a channel is closed regardless of how it was closed: by a SCPI command, front panel control, or during a scan. These counts are permanently written to the EEPROM on the card only at a user-settable time interval (which has a factory default of 15 minutes) or whenever the counts are queried. Valid intervals (set in integer number of minutes) are between 1 and 1440 minutes (24 hours). Relay closures are counted only when a relay cycles from open to closed state. If you send multiple close commands to the same channel without sending an open command, only the first closure will be counted.

The lower the interval, the less chance there is of losing relay counts due to power failures. However, writing to the EEPROM more often may reduce scanning throughput. The higher the interval, the less scanning throughput is reduced, but more relay counts may be lost in the event of a power failure.

To set the count update interval, send this command:

```
:ROUTe:CLOSe:COUNT:INTerval <interval>
```

For example, to set the interval to 30 minutes, send this command:

```
:ROUT:CLOS:COUN:INT 30
```

Troubleshooting

In this section:

Introduction	4-1
Repair considerations	4-2
Power-on self-tests	4-2
Front panel tests	4-3
Principles of operation.....	4-4
Circuit troubleshooting	4-13

Introduction

This section of the manual will assist you in troubleshooting and repairing the 2701. Included are self-tests, test procedures, troubleshooting tables, and circuit descriptions. It is left to the discretion of the repair technician to select the appropriate tests and documentation needed to troubleshoot the instrument. Refer to [Disassembly](#) (on page 5-1) for further information.

WARNING

Do not attempt to perform this procedure unless you are qualified, as described by the types of product users in the Safety precautions. Do not perform these procedures unless qualified to do so. Failure to recognize and observe normal safety precautions could result in personal injury or death.

Repair considerations

Before making any repairs to the 2701, be sure to read the following considerations.

CAUTION

The PC boards are built using surface-mount techniques and require specialized equipment and skills for repair. If you are not equipped and/or qualified, it is strongly recommended that you send the unit back to the factory for repairs or limit repairs to the PC board replacement level. Without proper equipment and training, you could damage a PC board beyond repair.

- Repairs will require various degrees of disassembly. However, it is recommended that the Front Panel Tests be performed prior to any disassembly. See [Disassembly](#) (on page 5-1).
- Do not make repairs to surface mount PC boards unless equipped and qualified to do so.
- When working inside the unit and replacing parts, be sure to adhere to the handling precautions and cleaning procedures explained in [Disassembly](#) (on page 5-1).
- Many CMOS devices are installed in the 2701. These static-sensitive devices require special handling as explained in [Disassembly](#) (on page 5-1).
- Whenever a circuit board is removed or a component is replaced, the 2701 must be recalibrated. See [Calibration](#) (on page 2-1).

Power-on self-tests

RAM and EPROM tests

During the power-on sequence, the 2701 will perform a checksum test on its EPROM and test its RAM. If the RAM tests fails, the instrument will lock up.

Flash memory tests

After the RAM and EPROM tests, the instrument will perform a checksum test on flash memory. If a failure occurs, the unit will perform the comprehensive tests summarized in the next table. If a failure occurs, an error message will be displayed, and the unit will automatically enter the firmware upgrade mode (as indicated by "FW UPGRADE" message). Depending on the failure mode, firmware upgrades can be performed through the port listed in the table. You can also force the unit into the firmware upgrade mode by holding the **STEP** key during power-up.

Flash memory code sections*	Status and error messages	Firmware upgrade port***
FPGA	LOADING FPGA FPGA CHKSUM** FPGA TIMEOUT** FPGA COMMERR**	RS-232
Ethernet	LOAD ETHRNET ETHER CHKSUM** ETHR TIMEOUT**	RS-232
Main code	LOADING MAIN MAIN CHKSUM**	RS-232 or Ethernet

* Code sections tested in sequence shown.

** Error message displayed only on failure of specific test.

*** Firmware upgrade can be performed only through indicated port, depending on failure mode.

Front panel tests

There are two front panel tests: one to test the functionality of the front panel keys and one to test the display. In the event of a test failure, refer to [Display board checks](#) (on page 4-13) for details on troubleshooting the display board.

KEY test

The KEY test allows you to check the functionality of each front panel key.

To run the KEY test:

1. Press **SHIFT** and then **TEST** to access the self-test options.
2. Use the up or down **RANGE** key to display "TEST: KEY."
3. Press **ENTER** to start the test. When a key is pressed, the label name for that key is displayed to indicate that it is functioning properly. When the key is released, the message "NO KEY PRESS" is displayed.
4. Pressing **EXIT** tests the **EXIT** key. However, the second consecutive press of **EXIT** aborts the test and returns the instrument to normal operation.

DISP test

The display test allows you to verify that each segment and annunciator in the vacuum fluorescent display is working properly.

To run the display test:

1. Press **SHIFT** and then **TEST** to access the self-test options.
2. Use the up or down **RANGE** key to display `TEST: DISP`.
3. Press **ENTER** to start the test. There are four parts to the display test. Each time **ENTER** is pressed, the next part of the test sequence is selected. The four parts of the test sequence are as follows:
 - a. All annunciators are displayed.
 - b. The segments of each digit are sequentially displayed.
 - c. The 12 digits (and annunciators) are sequentially displayed.
 - d. The annunciators located at either end of the display are sequentially displayed.
4. When finished, abort the display test by pressing **EXIT**. The instrument returns to normal operation.

Principles of operation

The following information is provided to support the troubleshooting tests and procedures covered in this section of the manual. Refer to the following block diagrams.

Power supply

The following information provides some basic circuit theory that can be used as an aid to troubleshoot the power supply. A block diagram of the power supply is shown in the next figure.

Figure 25: Power supply block diagram

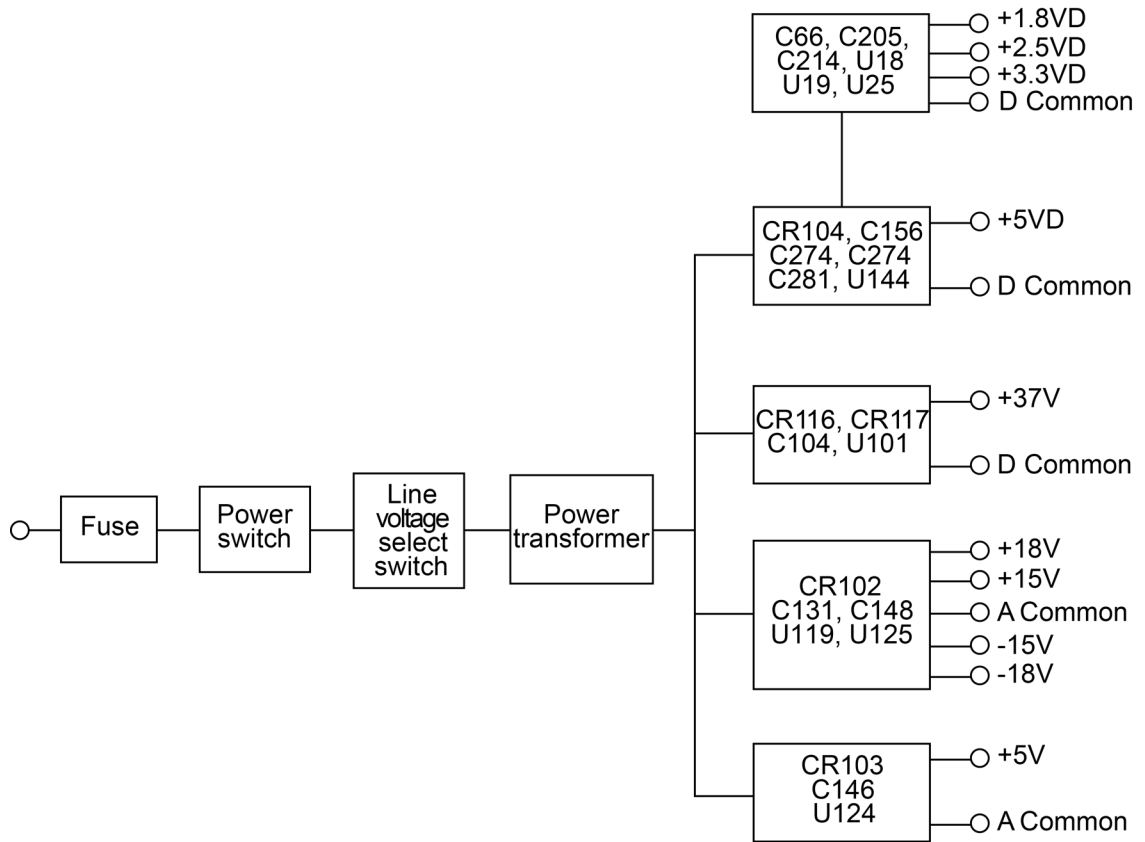

AC power is applied to the AC power module receptacle. Power is routed through the line fuse and line voltage selection switch of the power module to the power transformer. The power transformer has a total of four secondary windings for the various supplies.

AC voltage for the display filaments is taken from a power transformer secondary at F1 and F2, then routed to the display board.

Each DC supply uses a rectifier and a capacitive filter, and many supplies use an IC regulator. The next table summarizes rectifier, filter, and regulator circuits for the various DC supplies.

Supply	Rectifier	Filter	Regulator
+5 VD	CR104	C156, C273, C274, C281	U144
+3.3 VD	-	C66	U18
+2.5 VD	-	C205	U25
+1.8 VD	-	C214	U19
+37 V	CR115, CR117	C104	U101
+15 V	CR102	C148	U125
-15 V	CR102	C131	U119
+5 V, +5 VRL, +5 V2	CR103	C146	U124
+18 V	CR102	C148	-
-18 V	CR102	C131	-

Display board

Display board components are shown in the digital circuitry block diagram in the next figure.

Microcontroller

U401 is the display board microcontroller that controls the display and interprets key data. The microcontroller uses three internal peripheral I/O ports for the various control and read functions.

Display data is serially transmitted to the microcontroller from the digital section via the TXB line to the microcontroller RDI terminal. In a similar manner, key data is serially sent back to the digital section through the RXB line via TDO. The 4 MHz clock for the microcontroller is generated by crystal Y401.

Figure 26: Digital circuitry block diagram

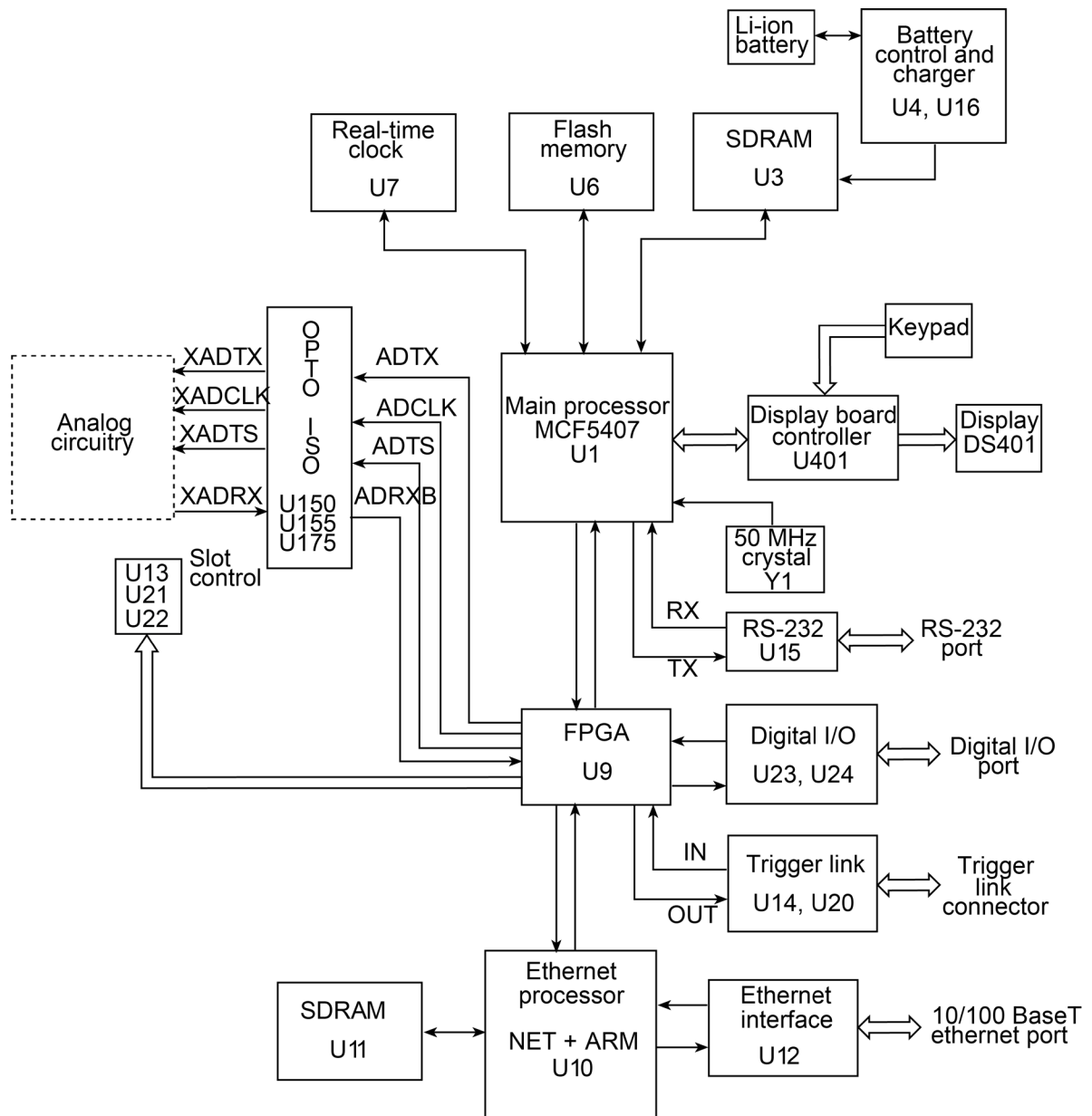

Display

DS401 is the display module, which can display up to 12 alpha-numeric characters and includes the various annunciators.

The display uses a common multiplexing scheme with each character refreshed in sequence. U402 and U403 are the drivers for the display characters and annunciators. Note that data for the drivers are serially transmitted from the microcontroller (MOSI and PC1).

Filament voltage for the display is derived from the power supply transformer (F1 and F2). The display drivers require +37 VDC and +5 VDC, which are supplied by U144 (+5VD) and U101 (+37V).

Key matrix

The front panel keys (S401-S430) are organized into a row-column matrix to minimize the number of microcontroller peripheral lines required to read the keyboard. A key is read by strobing the columns and reading all rows for each strobed column. Key-down data is interpreted by the display microcontroller and sent back to the main microprocessor using proprietary encoding schemes.

Digital circuitry

Refer to the previous figure for the following discussion on digital circuitry.

Main microprocessor

U1 is an MCF5407 microprocessor that oversees all operating aspects of the instrument except the Ethernet interface (see below). The MPU has a 32-bit data bus and provides a 24-bit address bus. It also has integrated peripheral support such as 16-bit I/O, an integral DRAM controller with SDRAM support, and UARTs, one of which is used for the RS-232 interface.

The MPU clock frequency of 50 MHz is controlled by crystal Y1. MPU RESET is performed momentarily on power-up.

Memory circuits

U6 is the flash memory that stores the firmware code for instrument operation and SDRAM U3 provides temporary storage for the MPU. A battery watchdog control automatically senses when the +5 VDC supply is being powered down and then switches to the lithium ion battery for power. Battery charge is maintained by U4 and associate components.

Real time clock

U7 is the real time clock. The clock runs from main power and switches to two 0.33 F capacitors (C43, C44) on power down and can hold the time for up to six months.

RS-232 interface

Serial data transmission and reception is performed by the TXD and RXD lines of the MPU. U15 provides the necessary voltage level conversion for the RS-232 interface port.

Trigger circuits

Buffering for Trigger Link input and output is performed by U14 and U20. Trigger input and output is controlled by FPGA U9 under MPU supervision.

Digital I/O

U23 and U24 make up the digital input/output. Digital I/O is controlled by the FPGA U9 under MPU supervision.

Module slot control

U13 and U21 make up the control circuitry that allows communication of relay data to slot 1 or slot 2.

Ethernet interface

U10 is a NET+ARM 32-bit RISC processor that supervises Ethernet port operation. This IC includes an integrated 10/100BaseT MAC as well as numerous other features such as two serial ports, DMA controller, and general-purpose I/O lines. U1 is the ARM processor memory IC, while U12 provides Ethernet port I/O buffering and drive capabilities.

Analog circuitry

Refer to the next figure for the following discussion on analog circuitry.

INPUT HI

INPUT HI protection is provided by the SSP (Solid State Protection) circuit. The SSP is primarily made up of Q101 and Q102. An overload condition opens Q101 and Q102, which disconnects the analog input signal from the rest of the analog circuit.

Note that for the 100 VDC and 1000 VDC ranges, Q101 and Q102 of the SSP are open. The DC voltage signal is routed through the DCV divider (Q114 and Q136) to the DCV switching circuit.

AMPS input

The ACA or DCA input signal is applied to the current shunt circuit, which is made up of K103, R158, R205, and R338. For the 20mA DC range, 5.1Ω ($R205/[R338 + R158]$) is shunted across the input. Relay K103 is energized (set state) to select the shunts. For all other DCA ranges and all ACA ranges, 0.1Ω (R158) is shunted across the input (K103 reset).

The ACA signal is then sent to the AC switching & gain circuit, while the DCA signal is routed directly to the A/D MUX & gain circuit.

Signal switching

Signal switching for DCV and OHMS is done by the DCV & ohms switching circuit. FETs Q113, Q105, Q104, and Q108 connect the DCV or ohms signal to the X1 buffer (U113).

Note that the reference current for OHMS is generated by the ohms I-source circuit. For 4-wire ohms measurements, SENSE LO is connected to U126.

Signal switching and gain for ACV, FREQ and ACA is done by the AC switching & gain circuit, which is primarily made up of K102, U102, U103, U105, U112, U118, U111, and U110. Note that U111 is used for frequency adjustment. The states of these analog switches vary from unit to unit.

Multiplexer and A/D converter

All input signals, except FREQ, are routed to the A/D MUX & Gain circuit. The multiplexer (U163) switches the various signals for measurement. In addition to the input signal, the multiplexer also switches among reference and zero signals at various phases of the measurement cycle.

When the input signal is selected by the MUX, it is amplified by U132 and U166. Gain is controlled by switches in U129 and associated resistors.

The multiplexed signals of the measurement cycle are routed to the A/D converter (U165) where it converts the analog signals to digital form. The digital signals are then routed through an opto-isolator to the MPU to calculate a reading.

Figure 27: Analog circuitry block diagram

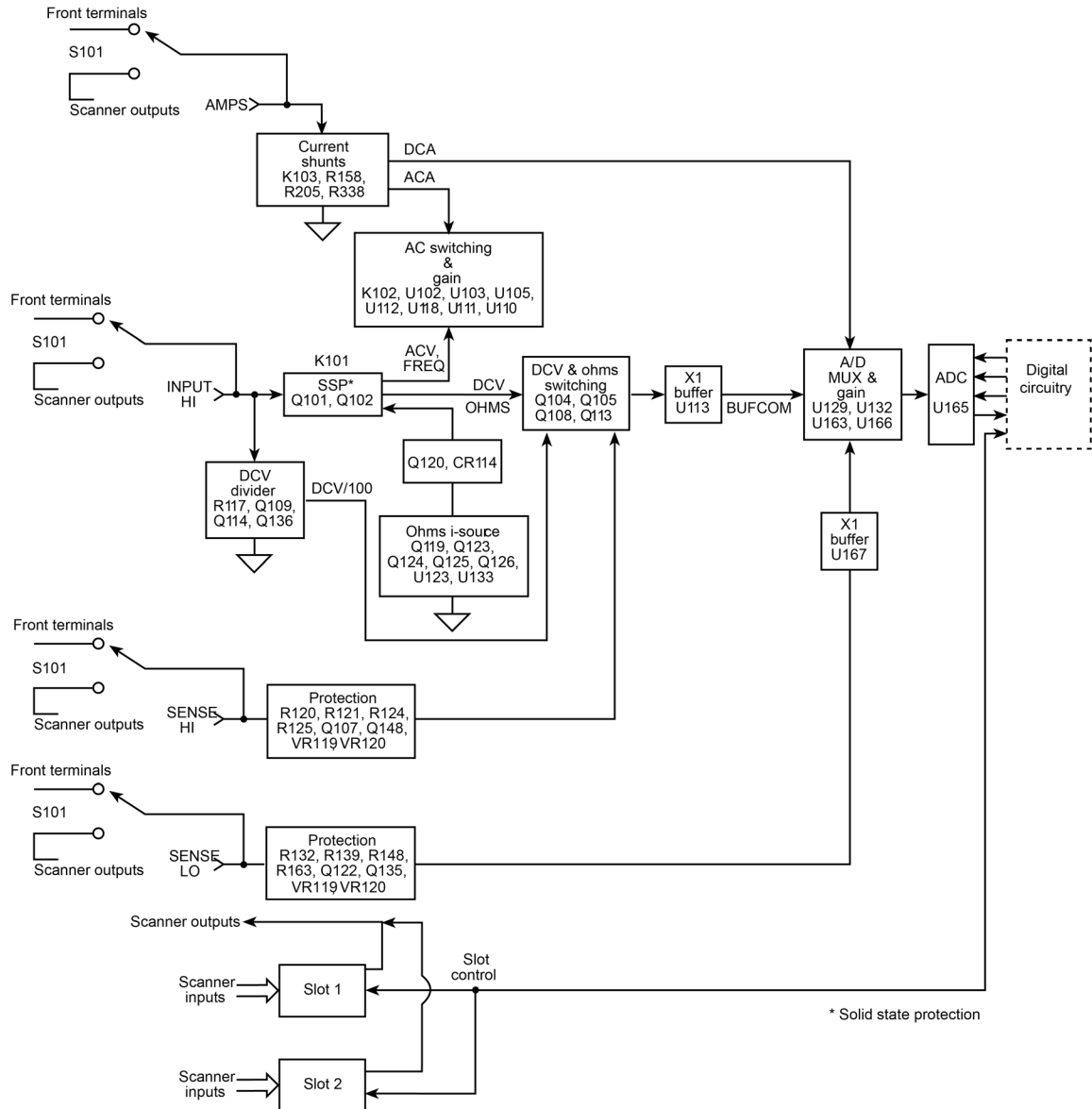

Ohms open-lead sense detection

There are two types of open sense lead detect. See the next figure. The first is for the INPUT HI and INPUT LO leads. For these leads, the open sense detection is implemented in hardware. A comparator circuit monitors the voltage at the INPUT HI lead output and will trip the OVLD detect circuit when the voltage level exceeds an appropriate value for the particular range. This circuit operates because the INPUT HI lead output is connected to a current source. If the lead is disconnected, it will quickly charge the output to the current source maximum voltage level. This level depends on the range. When the open sense lead is detected, the front panel will display OVRFLW.

The second type of open sense lead detection is implemented in software. This function works for the SENSE HI and SENSE LO leads. The SENSE HI and SENSE LO leads will drift negative when disconnected due to small leakage currents. These leads, when operating properly, will always have a positive voltage on them; and when disconnected, they will drift to negative voltages. The open lead sense software monitors the voltage at these inputs and will trip the open sense detect when the inputs drift to -15 mV. When the open sense condition is detected, the front panel will display OVRFLW.

Figure 28: Ohms open-lead sense detection block diagram

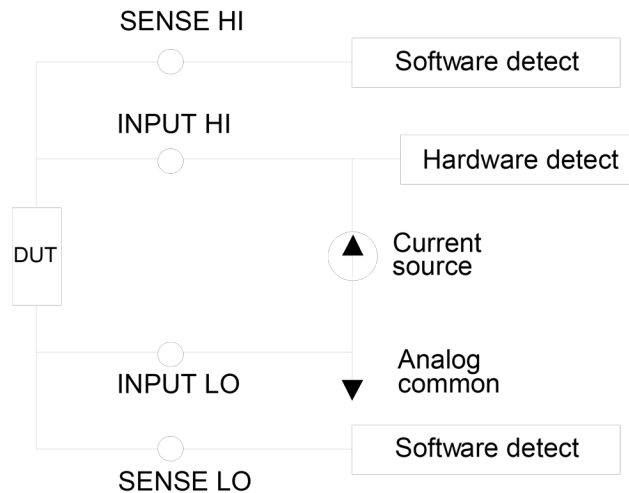

Scanner card signals

Scanner card input signals are connected directly to installed scanner cards. Scanner card output signals are routed internally to the INPUTS switch, which selects between the front panel terminals and the scanner card outputs.

Circuit troubleshooting

Troubleshooting information for the various circuits is summarized below. See [Principles of operation](#) (on page 4-4) for circuit theory.

Display board checks

If the front panel DISP tests show a failure, troubleshoot the display board using the following table.

Step	Item/component	Required condition	Remarks
1	Front panel DISP test	Verify that all segments operate.	Use front panel display test.
2	P1005, pin 5	+5 V \pm 5%	Digital +5V supply.
3	P1005, pin 9	+37 V \pm 5%	Display +37V supply.
4	U401, pin 1	Goes low briefly on power up, then goes high.	Microcontroller RESET.
5	U401, pin 43	4MHz square wave.	Controller 4MHz clock.
6	U401, pin 32	Pulse train every 1 ms.	Control from main processor.
7	U401, pin 33	Brief pulse train when front panel key is pressed.	Key down data sent to main processor.

Power supply checks

Power supply problems can be checked using the following table.

Step	Item/component	Required condition	Remarks
1	Line fuse	Check continuity.	Remove to check.
2	Line voltage	120 V/240 V as required.	Check power module position.
3	Line power	Plugged into live receptacle, power on.	Check for correct power-up sequence.
4	+5 VD pad	+5 V \pm 5%	+5 VD, referenced to Common D.*
5	+3.3 VD pad	+3.3 V \pm 5%	+3.3 VD, referenced to Common D.*
6	+2.5 VD pad	+2.5 V \pm 5%	+2.5 VD, referenced to Common D.*
7	+1.8 VD pad	+1.8 V \pm 5%	+1.8 VD, referenced to Common D.*
8	U101, pin 7	+37 V \pm 5%	+37 V, referenced to Common D.*
9	U125, pin 3	+15 V \pm 5%	+15 V, referenced to Common A.**
10	U119, pin 3	-15 V \pm 5%	-15 V, referenced to Common A.**
11	U124, pin 3	+5V \pm 5%	+5 VRL, referenced to Common A. ²

* U144, pin 2

** C293 negative terminal

Digital circuitry checks

Digital circuit problems can be checked using the following table.

Step	Item/component	Required condition	Remarks
1	Power-on test	RAM OK, ROM OK.	Verify that RAM and ROM are functional.
2	J1, pin 3	Digital common.	All signals referenced to digital common. MPU supply voltage.
3	J1, pin 9	+3.3 V (+3.3 VD supply)	Battery backed memory charge voltage.
4	U4, pin 9	+4.2 V	Battery voltage (BA-52).
5	J900, pin 1	+4.2 V	MPU RESET line.
6	U1, pin 149	Low on power-up, then goes high.	MPU address bus.
7	U1, lines A0-A24	Check for stuck bits.	MPU data bus.
8	U1, lines D0-D31	Check for stuck bits.	MPU clock.
9	U1, pin 174	50 MHz	RS-232 RX line.
10	U15, pin 13	Pulse train during RS-232 I/O.	RS-232 TX line.
11	U15, pin 14	Pulse train during RS-232 I/O.	Signal present if main code is running properly.
12	TP8	500 Hz signal.	

Analog signal switching states

The following tables provide switching states of the various relays, FETs, and analog switches for the basic measurement functions and ranges. These tables can be used to assist in tracing an analog signal from the input to the A/D multiplexer.

DCV signal switching

Range	Q101	Q102	Q114	Q136	Q109	K101*	Q113	Q105	Q104	Q108	Q14/Q13
100 mV	ON	ON	OFF	OFF	OFF	SET	OFF	OFF	ON	OFF	OFF
1 V	ON	ON	OFF	OFF	OFF	SET	OFF	OFF	ON	OFF	OFF
10 V	ON	ON	OFF	OFF	OFF	SET	OFF	OFF	ON	OFF	ON
100 V	OFF	OFF	ON	ON	OFF	SET	OFF	OFF	OFF	ON	OFF
1000 V	OFF	OFF	ON	ON	OFF	SET	OFF	OFF	OFF	ON	OFF

* K101 set states: Pin 8 switched to Pin 7
Pin 3 switched to Pin 4

ACV and FREQ signal switching

Range	Q101	Q102	K101*	K102*	U103 pin 8	U103 pin 9	U105 pin 9	U105 pin 8	U103 pin 16	U103 pin 1	U105 pin 1	U111 pin 16
100 mV	ON	ON	RESE	RESE	ON	ON	OFF	OFF	OFF	ON	ON	OFF
1 V	ON	ON	T	T	ON	ON	OFF	OFF	ON	OFF	OFF	OFF
10 V	ON	ON	RESE	RESE	OFF	OFF	ON	OFF	OFF	ON	ON	OFF
100 V	ON	ON	T	T	OFF	OFF	ON	OFF	ON	OFF	OFF	OFF
750 V	ON	ON	RESE	SET	OFF	OFF	ON	ON	OFF	OFF	OFF	OFF
			T	SET								
			RESE	SET								
			T	SET								
			RESE									
			T									

*K101 and K102 reset states: Pin 8 switched to Pin 9
Pin 3 switched to Pin 2

K101 and K102 set states: Pin 8 switched to Pin 7
Pin 3 switched to Pin 4

Ω signal switching

Range	Q101	Q102	Q114	Q136	Q109	K101*	K102*	Q113	Q105	Q104	Q108	Q11
100 Ω	ON	ON	OFF	OFF	OFF	SET	RESET	OFF	ON	OFF	OFF	ON
1 kΩ	ON	ON	OFF	OFF	OFF	SET	RESET	OFF	ON	OFF	OFF	ON
10 kΩ	ON	ON	OFF	OFF	OFF	SET	RESET	OFF	ON	OFF	OFF	ON
100 kΩ	ON	ON	OFF	OFF	OFF	SET	RESET	OFF	ON	OFF	OFF	OFF
1 MΩ	ON	ON	OFF	OFF	OFF	SET	RESET	OFF	ON	OFF	OFF	OFF
10 MΩ	ON	ON	OFF	OFF	ON	SET	RESET	OFF	ON	OFF	OFF	ON
100 MΩ	ON	ON	OFF	OFF	ON	SET	RESET	OFF	ON	OFF	OFF	ON

*K101 set states: Pin 8 switched to Pin 7
Pin 3 switched to Pin 4

K102 reset states: Pin 8 switched to Pin 9
Pin 3 switched to Pin 2

Ω4 signal switching

Range	Q101	Q102	Q114	Q136	Q109	K101*	Q113	Q105	Q104	Q108	Q11
100 Ω	ON	ON	OFF	OFF	OFF	SET	ON	OFF	OFF	OFF	ON
1 kΩ	ON	ON	OFF	OFF	OFF	SET	ON	OFF	OFF	OFF	ON
10 kΩ	ON	ON	OFF	OFF	OFF	SET	ON	OFF	OFF	OFF	ON
100 kΩ	ON	ON	OFF	OFF	OFF	SET	ON	OFF	OFF	OFF	OFF
1 MΩ	ON	ON	OFF	OFF	OFF	SET	ON	OFF	OFF	OFF	OFF
10 MΩ	ON	ON	OFF	OFF	ON	SET	OFF	ON	OFF	OFF	ON
100 MΩ	ON	ON	OFF	OFF	ON	SET	OFF	ON	OFF	OFF	ON

*K101 set states: Pin 8 switched to Pin 7
Pin 3 switched to Pin 4

Ω2/Ω4 reference switching

Range	U133/0.7V	U133/7V	Q123	Q125	Q124	Q126	Q120
100 Ω	OFF	ON	ON	ON	OFF	OFF	ON
1 kΩ	OFF	ON	ON	ON	OFF	OFF	ON
10 kΩ	OFF	ON	OFF	OFF	ON	ON	ON
100 kΩ	ON	OFF	OFF	OFF	ON	ON	ON
1 MΩ	ON	OFF	OFF	OFF	ON	ON	ON
10 MΩ	OFF	ON	OFF	OFF	ON	ON	OFF
100 MΩ	OFF	ON	OFF	OFF	ON	ON	OFF

DCA signal switching

Range	K103*
20 mA	Set
100 mA	Reset
1 A	Reset
3 A	Reset

*K103 set states: Pin 8 to 7
Pin 3 to 4
K103 reset states: Pin 8 to 9
Pin 3 to 2

ACA signal switching

Range	K103*	U105 pin 16	U105 pin 1	U111 pin 16	U105 pin 8	U103 pin 16	U103 pin 1
1 A	Reset	ON	ON	OFF	OFF	OFF	OFF
3 A	Reset	ON	ON	ON	OFF	OFF	OFF

*K103 set states: Pin 8 to 7
Pin 3 to 4
K103 reset states: Pin 8 to 9
Pin 3 to 2

The following tables can be used to trace the analog signal through the A/D multiplexer (U163) to the final amplifier stage. These tables show the MUX lines (S3, S4, S6, S7) that are selected for measurement during the SIGNAL phase of the multiplexing cycle. Also included are switching states of analog switches (U129) that set up the gain for the final amplifier stage (U166).

DCV signal multiplexing and gain

Range	Signal (U163)	U129 pin 1	U129 pin 8	U129 pin 9	Gain (U166)
100 mV	S4	OFF	OFF	ON	×100
1 V	S4	OFF	ON	OFF	×10
10 V	S4	ON	OFF	OFF	×1
100 V	S4	OFF	ON	OFF	×10
1000 V	S4	ON	OFF	OFF	×1

ACV and ACA signal multiplexing and gain

Range	Signal (U163)	U129 pin 1	U129 pin 8	U129 pin 9	Gain (U166)
All	S3	ON	OFF	OFF	×1

DCA signal multiplexing and gain

Range	Signal (U163)	U129 pin 1	U129 pin 8	U129 pin 9	Gain (U166)
20 mA	S6	OFF	OFF	ON	×100
100 mA	S6	OFF	OFF	ON	×100
1 A	S6	OFF	OFF	ON	×100
3 A	S6	OFF	ON	OFF	×10

Ω2 signal multiplexing and gain

Range	Signal (U163)	U129 pin 1	U129 pin 8	U129 pin 9	Gain (U166)
100 Ω	S4	OFF	OFF	ON	×100
1 kΩ	S4	OFF	ON	OFF	×10
10 kΩ	S4	OFF	ON	OFF	×10
100 kΩ	S4	OFF	ON	OFF	×10
1 MΩ	S4	ON	OFF	OFF	×1
10 MΩ	S4	ON	OFF	OFF	×1
100 MΩ	S4	ON	OFF	OFF	×1

Ω4 signal multiplexing and gain

Range	Signal (U163)	U129 pin 1	U129 pin 8	U129 pin 9	Gain (U166)
100 Ω	S4 then S7	OFF	OFF	ON	×100
1 kΩ	S4 then S7	OFF	ON	OFF	×10
10 kΩ	S4 then S7	OFF	ON	OFF	×10
100 kΩ	S4 then S7	OFF	ON	OFF	×10
1 MΩ	S4 then S7	ON	OFF	OFF	×1
10 MΩ	S4 then S7	ON	OFF	OFF	×1
100 MΩ	S4 then S7	ON	OFF	OFF	×1

Switching device locations

Switching devices	Analog circuit section
Q101, Q102	SSP (solid state protection)
Q114, Q136, Q109	DCV divider
K101, Q113, Q105, Q104, Q108	DCV and ohms switching
Q121	Sense LO
K102, U103, U105, U111	AC switching and gain
U133, Q119, Q123, Q124, Q125, Q126	Ohms I-Source
K103	Current shunts
U129, U163	A/D MUX and gain

Disassembly

In this section:

Introduction	5-1
Handling and cleaning.....	5-1
Assembly drawings	5-3
Disassembly procedures.....	5-3
Instrument reassembly.....	5-6

Introduction

This section explains how to handle, clean, and disassemble the 2701 Ethernet Multimeter/Data Acquisition System.

Use the [Assembly drawings](#) (on page 5-3) located at the end of this section to assist you when disassembling and reassembling the instrument.

Handling and cleaning

To avoid contaminating PC board traces with body oil or other foreign matter, avoid touching the PC board traces while you are repairing the instrument. Some circuit board areas, especially those under the motherboard shield, have high-impedance devices or sensitive circuitry where contamination could cause degraded performance.

Handling PC boards

Observe the following precautions when handling PC boards:

- Wear cotton gloves.
- Only handle PC boards by the edges and shields.
- Do not touch any board traces or components not associated with repair.
- Do not touch areas adjacent to electrical contacts.
- Use dry nitrogen gas to clean dust from PC boards.

Solder repairs

Observe the following precautions when soldering a circuit board:

- Use an OA-based (organic-activated) flux and take care not to spread the flux to other areas of the circuit board.
- Remove the flux from the work area when you have finished the repair by using pure water with clean, foam-tipped swabs or a clean, soft brush.
- Once you have removed the flux, swab only the repair area with methanol, then blow-dry the board with dry nitrogen gas.
- After cleaning, allow the board to dry in a 50 °C, low-humidity environment for several hours.

Static sensitive devices

CMOS devices operate at very high impedance levels. Therefore, any static that builds up on you or on your clothing may be sufficient to destroy these devices if they are not handled properly. Use the following precautions to avoid damaging them:

CAUTION

Many CMOS devices are installed in the 2701. Handle all semiconductor devices as being static sensitive.

- Transport and handle ICs only in containers designed specifically for preventing static build-up. Typically, you will receive these parts in anti-static containers made of plastic or foam. Keep these devices in their original containers until ready for installation.
- Remove the devices from their protective containers only at a properly grounded work station. Make sure to ground yourself with a suitable wrist strap.
- Handle the devices only by the body; do not touch the pins.
- Ground any printed circuit board into which a semiconductor device is to be inserted to the bench or table.
- Use only anti-static type desoldering tools.
- Use only grounded-tip soldering irons.
- Once the device is installed in the PC board, it is normally adequately protected, and you can handle the boards normally.

Assembly drawings

Use the following assembly drawings to assist you as you disassemble and reassemble the 2701. Also, refer to these drawings for information about the Keithley Instruments part numbers of most mechanical parts in the unit.

- [Front Panel Assembly](#)
- [Power Module / Card Cage Assembly](#)
- [Power Module / Transformer / Chassis Assembly](#)
- [Front Panel / Card Cage / Chassis Assembly](#)
- [Chassis Assembly](#)
- [Final Chassis Assembly](#)
- [Final Inspection](#)

Disassembly procedures

Case cover removal

WARNING

Before removing the case cover, disconnect the line cord and any test leads from the instrument.

To remove the handle, mounting ears, rear bezel, bottom screws, and cover:

1. Swing the handle below the bottom surface of the case and back until the orientation arrows on the handles line up with the orientation arrows on the mounting ears. Pull the ends of the handle away from the case.
2. Remove the screw that secures each mounting ear, then pull down and out on each mounting ear to remove.

NOTE

When re-installing the mounting ears, be sure to mount the right ear to the right side of the chassis and the left ear to the left side of the chassis. Each ear is marked RIGHT or LEFT on its inside surface.

3. Loosen the two captive screws that secure the rear bezel to the chassis, then pull the bezel away from the case.
4. Remove the four bottom screws that secure the case to the chassis.
5. Grasp the front bezel of the instrument and slide the chassis forward.
6. Slide the chassis out of the metal case.

Motherboard removal

To remove the motherboard:

1. Make sure that the case cover is already removed. See [Case cover removal](#) (on page 5-3).
2. Remove the nuts securing the RS-232 and Digital I/O connectors to the rear panel. Remove these nuts.
3. Place the edge of a flat-blade screwdriver in the notch on the front/rear inputs switch rod. Carefully twist the screwdriver while pulling the rod from the shaft.
4. Pull the wires off of the pin connectors for the INPUT HI, INPUT LO, SENSE HI, and SENSE LO front input terminal connections.
5. Remove the AMPS fuse holder, then use needle-nose pliers to grasp the AMPS wire near the fuse housing.
 - a. Push the wire forward and down to snap the spring out of the fuse housing.
 - b. Carefully pull the spring and contact tip out of the housing.
6. Unplug the following cables:
 - a. Unplug the display board ribbon cable from connector J1014.
 - b. Unplug the transformer cables from connectors J1002 and J6.
 - c. Unplug scanner slots ribbon cable from connector J1012.
 - d. Unplug analog backplane connections J1008 and J1010.
 - e. Unplug the battery cable from J1017.
 - f. Unplug the fan cable from J1018.
7. Remove the fastening screws that secure the motherboard to the chassis. One of these screws is located along the left side of the unit towards the middle and it also secures U144. One screw is located at the right center of the chassis near the front/rear switch, S101, and another screw is behind the AC shield. The final screw is near the rear panel next to J5.

NOTE

During re-assembly, replace the board and start the RS-232 and Digital I/O connector nuts and the mounting screw. Tighten all the fasteners once they are in place and the board is correctly aligned.

8. Slide the motherboard forward until the board edges clear the guides.
 - a. Carefully pull the motherboard from the chassis.

Card cage removal

After the motherboard has been removed, remove the card cage by removing the screws that attach the card cage to the bottom of the instrument case.

Front panel disassembly

To remove the display board and the pushbutton switch pad:

NOTE

You must first remove the case cover, the front/rear input switch, and the front input terminal wires. See [Case cover removal](#) (on page 5-3), [Motherboard removal](#) (on page 5-4), and [Card cage removal](#) (on page 5-4).

1. Unplug the display board ribbon cable from connector J1014.
2. Remove the four retaining clips that snap onto the chassis over four PEM® nut studs.
3. Pull the retaining clips on each side of the front panel outward and, at the same time, pull the front panel assembly forward until it separates from the chassis.
4. Using a thin-bladed screwdriver, pry the plastic PC board stop (located at the bottom of the display board) until the bar separates from the casing. Pull the display board from the front panel.
5. Pull the switch pad from the front panel.

Removing power components

The following procedures to remove the power transformer, power module, and fan require that the case cover and motherboard be removed. See [Disassembly procedures](#) (on page 5-3).

Power transformer removal

To remove the power transformer:

1. Remove the motherboard.
2. Remove the two nuts that secure the transformer to the side of the chassis.
3. Pull the black ground wire off the threaded stud and remove the power transformer from the chassis.

Power module removal

To remove the power module:

1. Remove the motherboard.
2. Remove the POWER switch rod.
3. Remove the card cage.
4. Disconnect the power module ground wire. This green and yellow wire connects to a threaded stud on the chassis with a Keps® nut.
5. Squeeze the latches on either side of the power module while pushing the module from the access hole.

Fan removal

To remove the fan:

1. Remove the motherboard.
2. Remove the four screws that secure the fan to the bottom of the chassis.
3. Remove the fan from the chassis.

Instrument reassembly

Reassemble the instrument by reversing the previous disassembly procedures. Make sure that all parts are properly seated and secured, and that all connections are properly made. Be sure to place and securely fasten the shield.

WARNING

To ensure continued protection against electrical shock, verify that power line ground (green and yellow wire attached to the power module) and the power transformer ground (black wire) are connected to the chassis. When installing the power transformer, be sure to reconnect the black ground wire to the mounting stud on side of the chassis. Make sure to install the bottom case screws to ensure a case-to-chassis ground connection.

Input terminal wire connections

You can use the following table during reassembly to connect the input terminal wires.

Input terminal	Wire color
INPUT HI	Red
INPUT LO	Black
SENSE HI	Yellow
SENSE LO	Gray
AMPS	White

Power module wire connections

You can use the following table during reassembly to connect the power module wires.

Location	Wire color
Right side	Gray
Right top	Violet
Left top	White
Right bottom	Red
Left bottom	Blue

2701-040

ON

LTR	ECA NO.	REVISION	ENG	DATE
A	27327	Released	ST	6/12/02
AI	27421	2700-110H Was 2700-110G1	ST	7/8/02

STEP 1

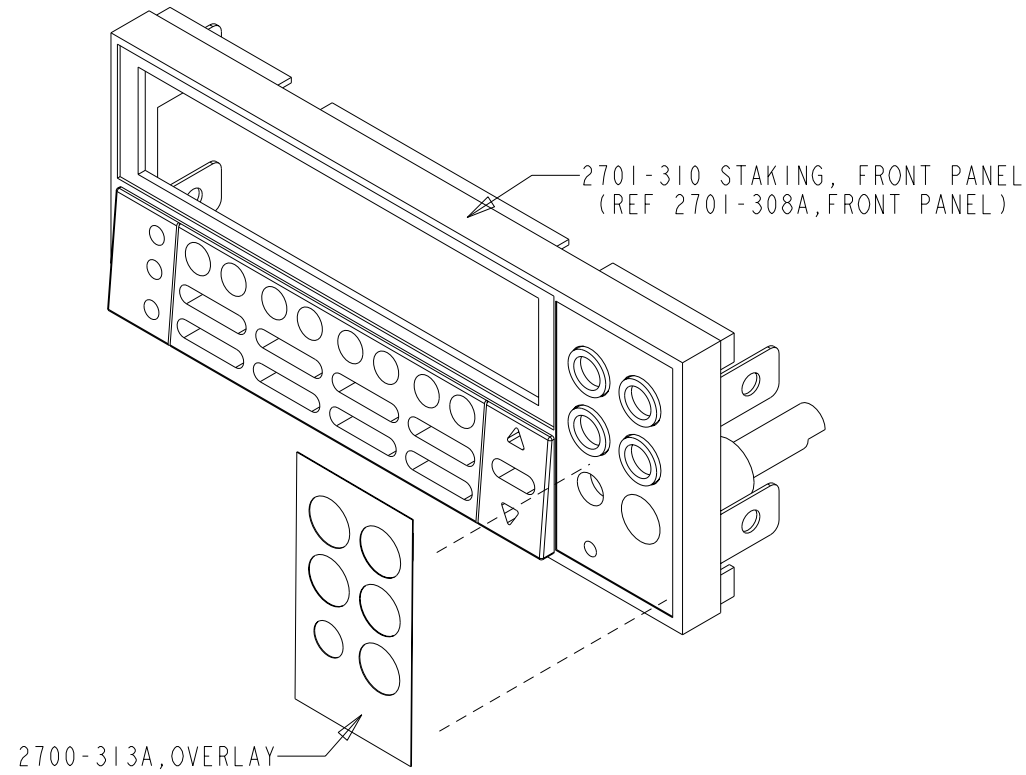

STEP 2

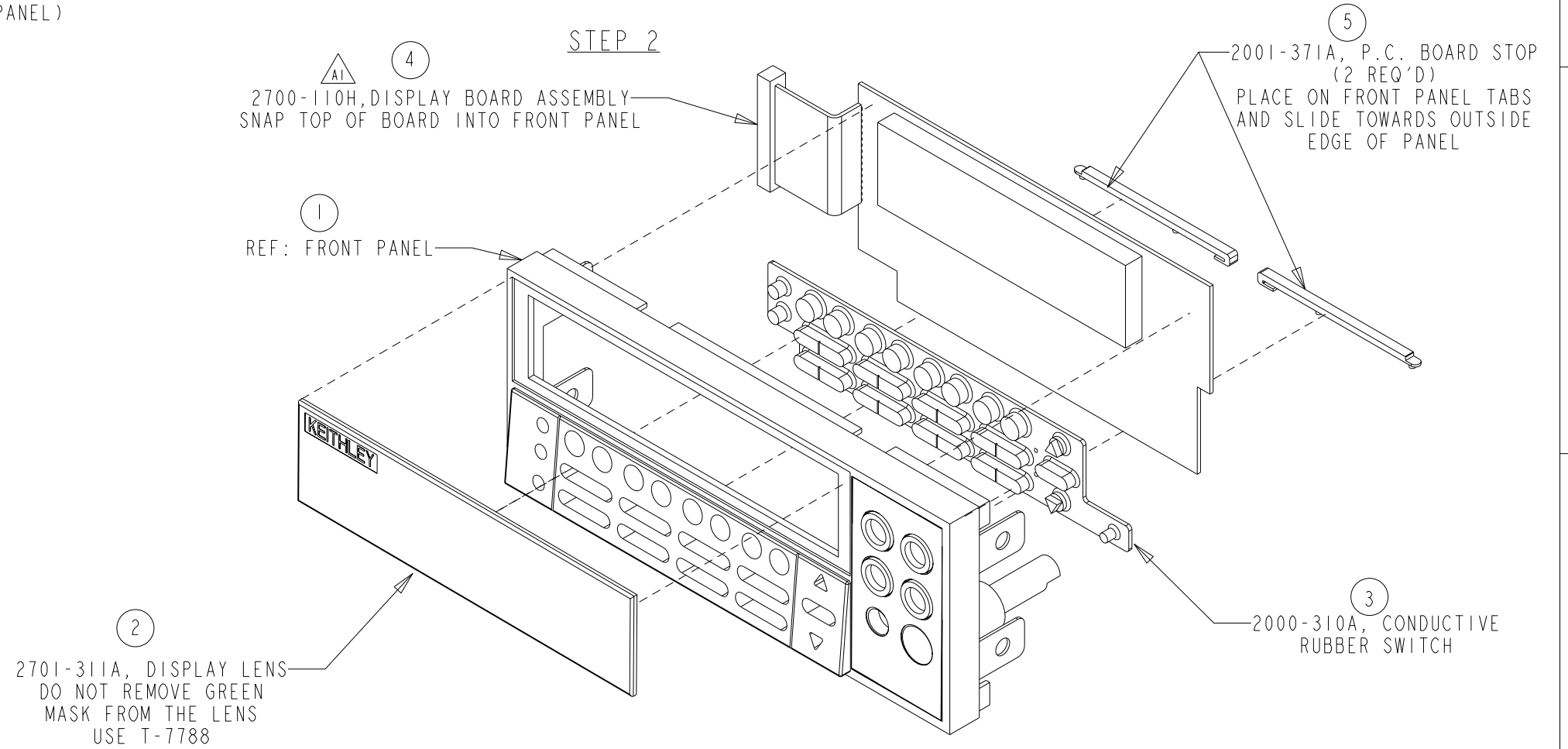

PART NUMBER	QTY	DESCRIPTION
2701-310	1	STAKING, FRONT PANEL (REF 2701-308A)
AI 2700-110H	1	DISPLAY BOARD ASSEMBLY
2700-313A	1	OVERLAY
2701-311A	1	DISPLAY LENS
2000-310A	1	CONDUCTIVE RUBBER SWITCH
2001-371A	2	P.C. BOARD STOP

MODEL	NEXT ASSEMBLY	NEXT PROCESS STEP	QTY
2701	2701-051	FP/Chassis Assembly	1
USED ON			

DO NOT SCALE THIS DRAWING

DIMENSIONAL TOLERANCES UNLESS OTHERWISE SPECIFIED

XX = ±.015 ANG. = ±1°

XXX = ±.005 FRAC. = ±1/64

SURFACE MAX. \sqrt{R}

DATE 19-Dec-01 SCALE - - - - TITLE Front Panel Assembly OP6

DRN. *Mat* ENG APPR. *LS*

MATERIAL FINISH

NO. 2701-040

KEITHLEY Keithley Instruments Inc. Cleveland, Ohio 44139

050-1022

ON

LTR	ECA NO.	REVISION	ENG	DATE
A	27327	Released	ST	6/12/02
AI	28093	Del Rev's From Part Numbers	ST	1/21/03

CARD CAGE ASSEMBLY

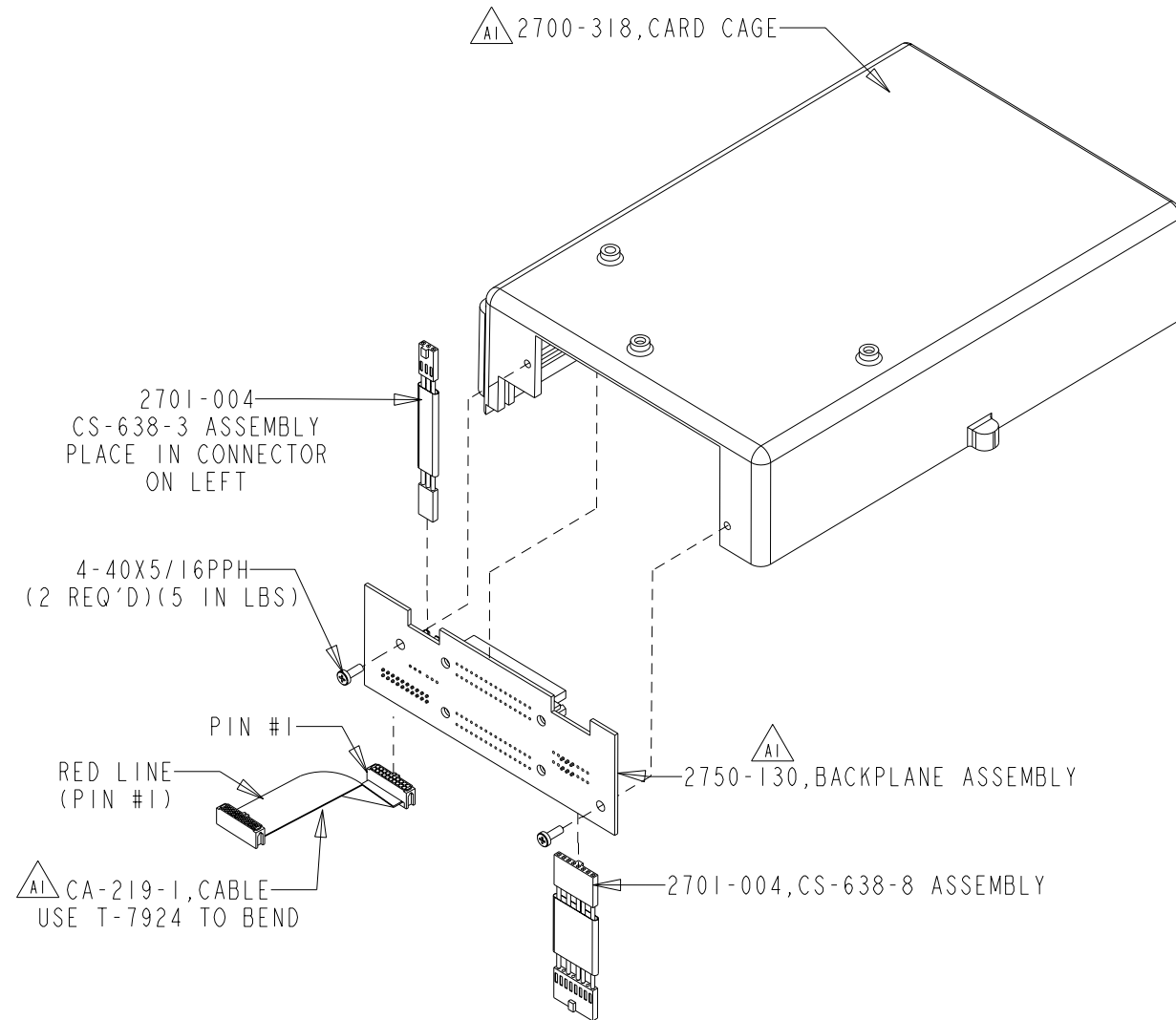

POWER MODULE ASSEMBLY

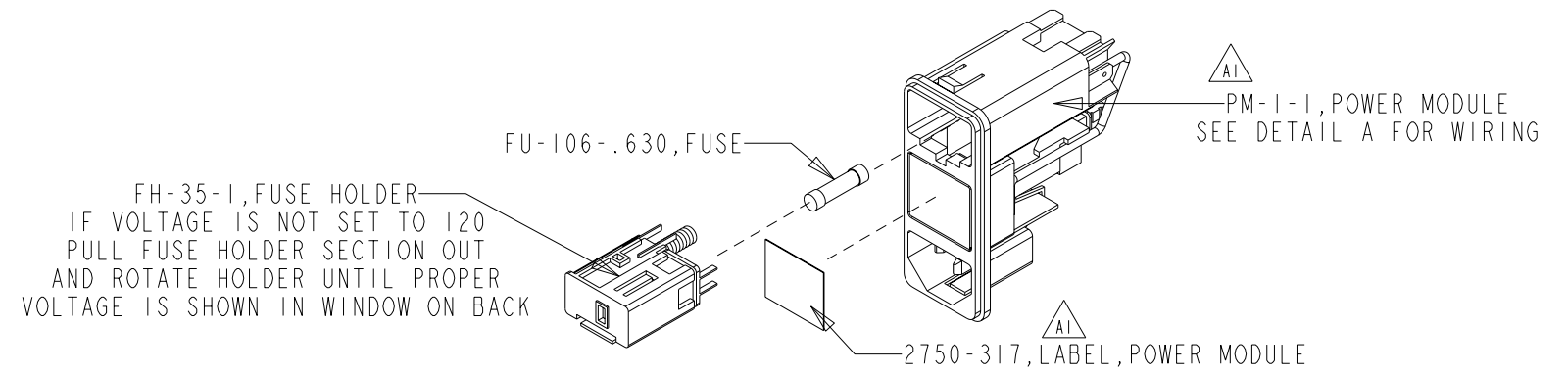

DETAIL A

TRANSFORMER WIRING

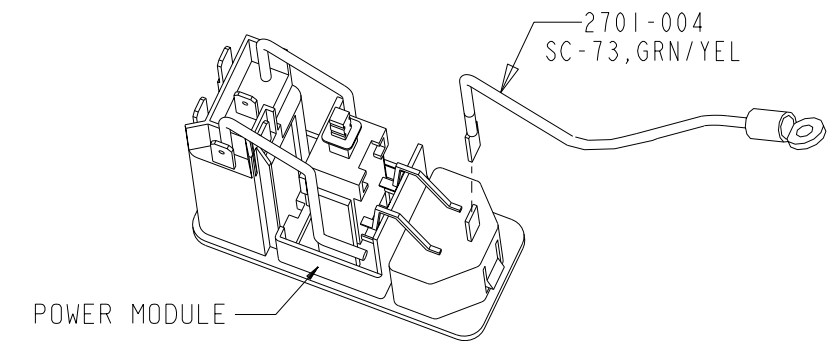

PART NUMBER	QTY	DESCRIPTION
2701-004	1	WIRE CRIMP ASSEMBLY
AI 2750-130	1	BACKPLANE BOARD ASSEMBLY
AI 2700-318	1	CARD CAGE
AI 2750-317	1	LABEL, POWER MODULE
AI CA-219-1	1	CABLE
FH-35-1	1	FUSE HOLDER
FU-106-.630	1	FUSE .630 AMP
AI PM-1-1	1	POWER MODULE
4-40x5/16PPH	2	PHIL PAN HEAD SCREW

2701	2701-051	Power Module/Chassis Assembly	1
MODEL	NEXT ASSEMBLY	NEXT PROCESS STEP	QTY
USED ON			

DO NOT SCALE THIS DRAWING		DIMENSIONAL TOLERANCES UNLESS OTHERWISE SPECIFIED		DATE 19-Dec-01	SCALE - - - - -	TITLE	
Keithley Instruments Inc. Cleveland, Ohio 44139 CONFIDENTIAL PROPRIETARY		XX = ±.015	ANG. = ±°	DRN. <i>Mat</i>	ENG APPR. <i>LS</i>	PM/Card Cage Assembly	
		XXX = ±.005	FRAC. = ±1/64	MATERIAL		B	NO. 2701-050
SURFACE MAX. $\sqrt{63}$		FINISH					

190-1022

ON

LTR	ECA NO.	REVISION	ENG	DATE
A	27327	Released	ST	6/12/02
AI	27541	Del Rev's From Parts	ST	9/14/02

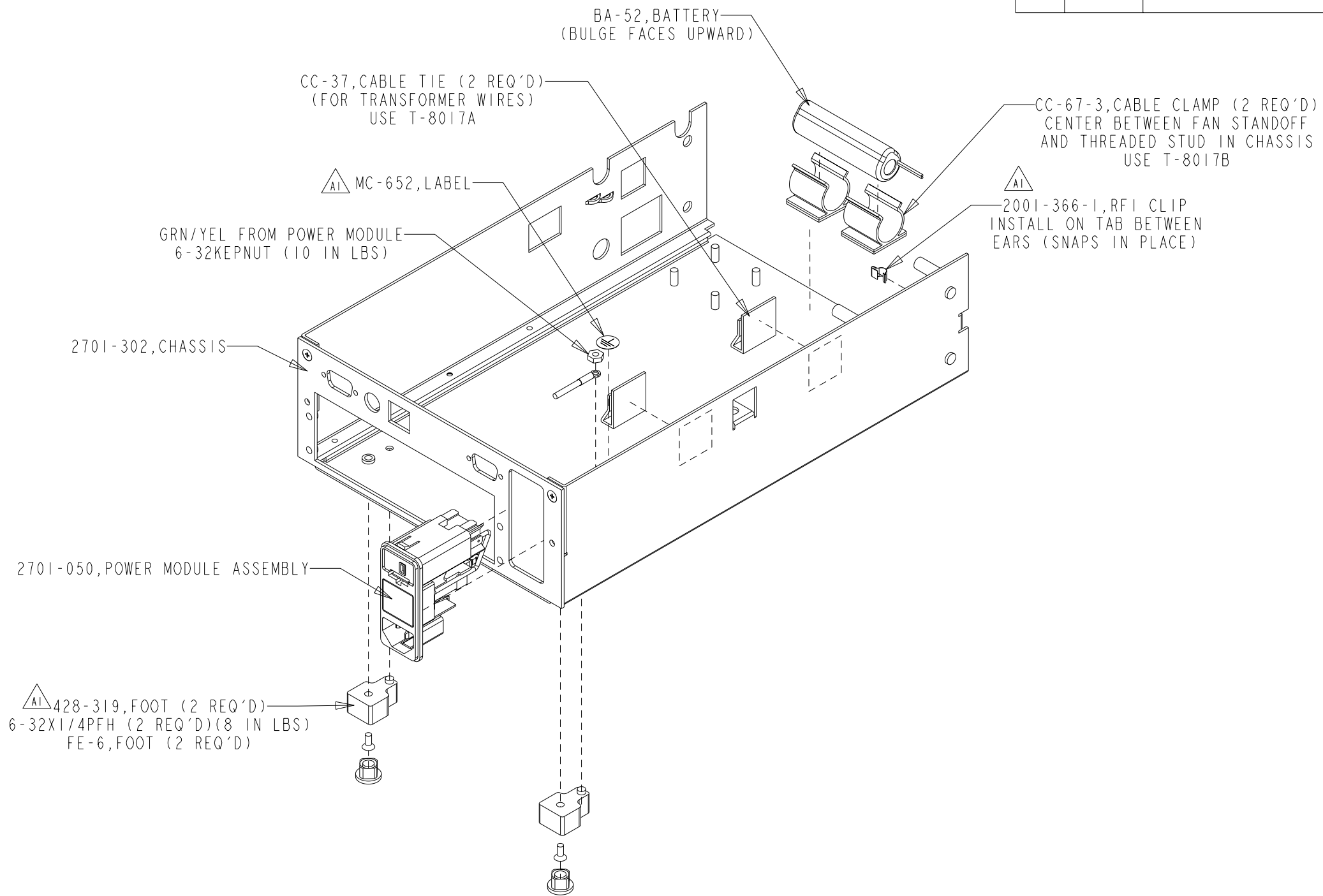

PART NUMBER	QTY	DESCRIPTION
AI 2001-366-1	1	RFI CLIP
2701-302 AI	1	CHASSIS
AI 428-319	2	FOOT
CC-37	2	CABLE CLAMP
FE-6	2	FOOT
2701-050	1	POWER MODULE ASSEMBLY
6-32x1/4PFH	2	PHIL FLAT HEAD SCREW
6-32KEPNUT	1	KEPNUT
BA-52	1	BATTERY
CC-67-3	2	CABLE CLAMP
AI MC-652	1	LABEL

MODEL	NEXT ASSEMBLY	NEXT PROCESS STEP	QTY
2701	2701-052	FP/Chassis Assembly	1
USED ON			

DO NOT SCALE THIS DRAWING	DIMENSIONAL TOLERANCES UNLESS OTHERWISE SPECIFIED		DATE 20-Dec-01	SCALE - - - - -	TITLE
	XX = ±.015	ANG. = ±°	DRN. <i>Mat</i>	ENG APPR. <i>LS</i>	Power Mod/Chassis Ass'y
SURFACE MAX. $\sqrt{63}$	XXX = ±.005	FRAC. = ±1/64	MATERIAL	B NO. 2701-051	
			FINISH		

KEITHLEY Keithley Instruments Inc.
Cleveland, Ohio 44139

2701-052

ON

LTR	ECA NO.	REVISION	ENG	DATE
B	27541	6-32X1/2PPHSEM Was 4-40X5/16PPH Del Rev's From Parts	ST	9/14/02

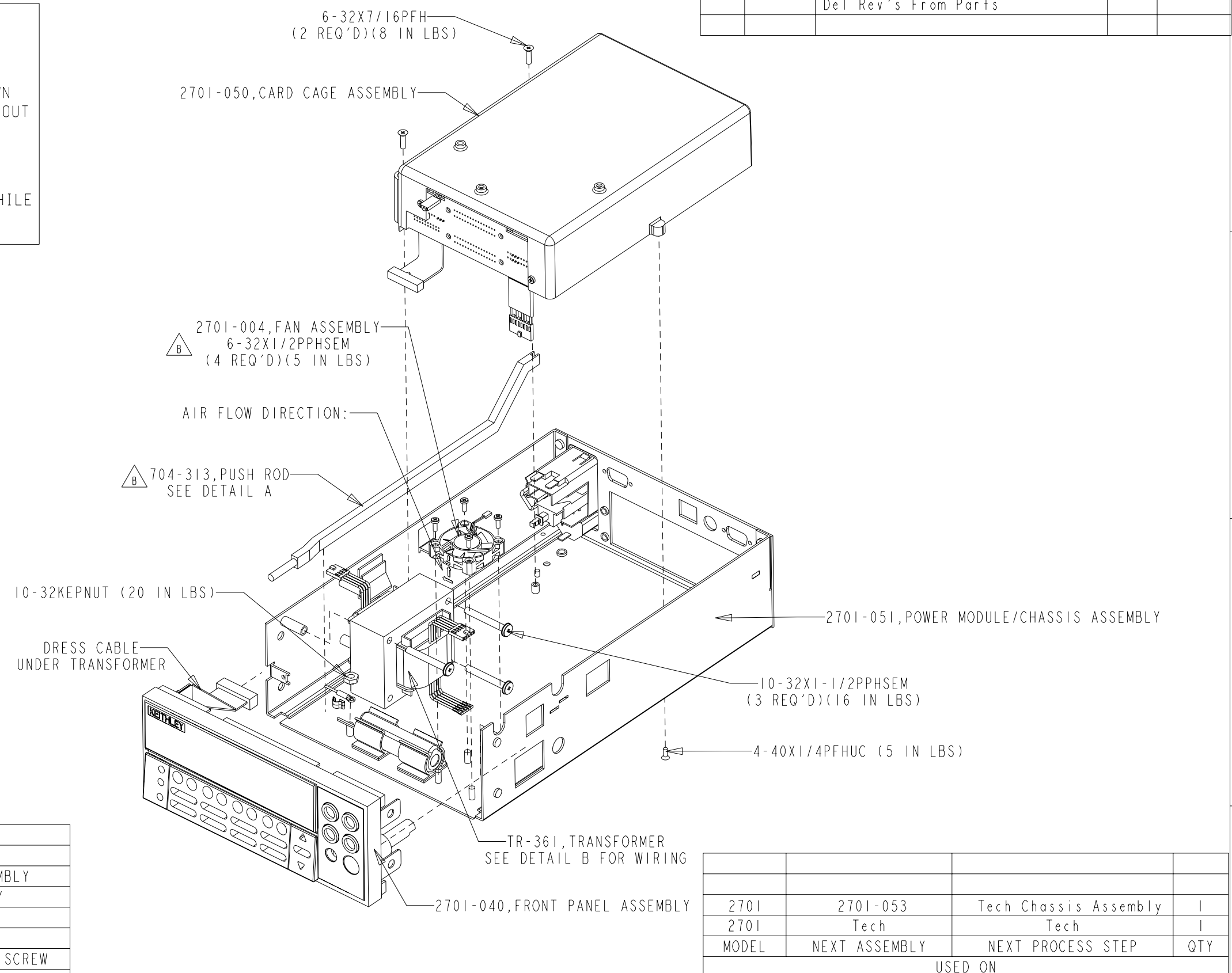
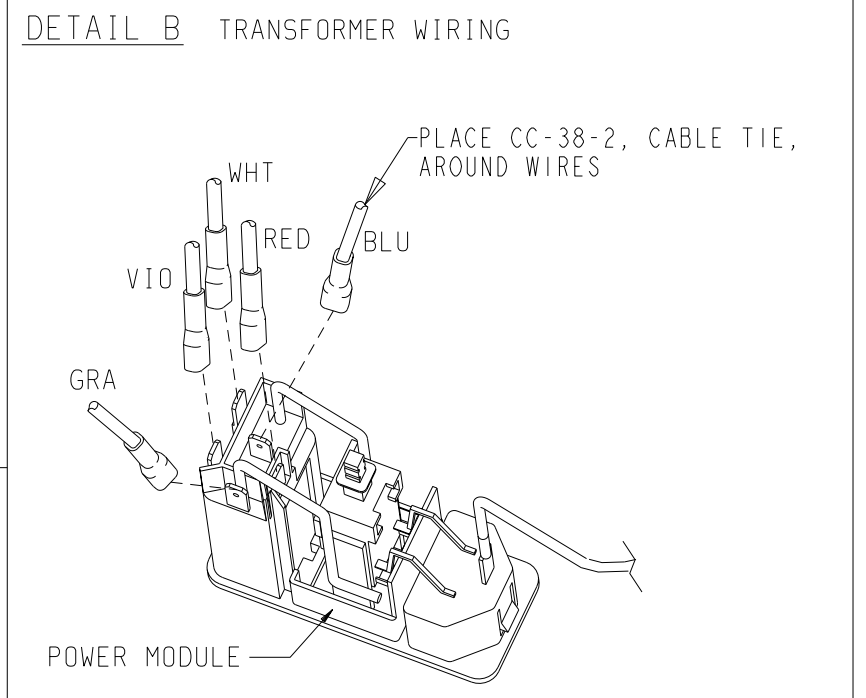
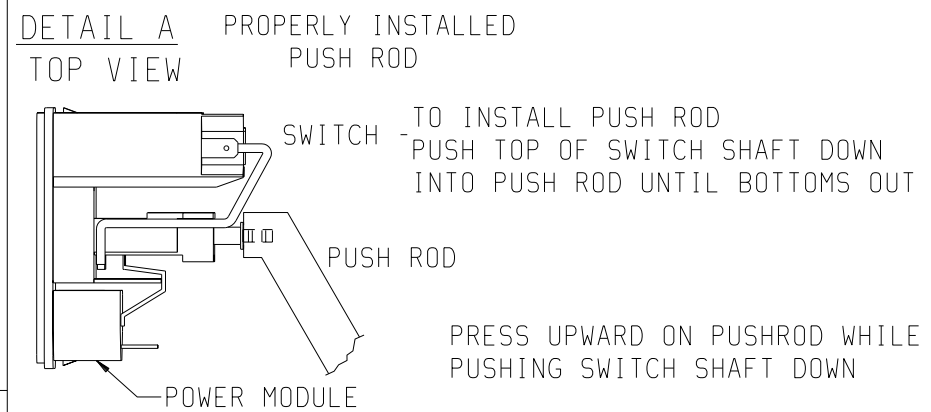

PART NUMBER	QTY	DESCRIPTION
2701-004	1	CRIMP ASSEMBLY
2701-051	1	POWER MOD/CHASSIS ASSEMBLY
2701-040	1	FRONT PANEL ASSEMBLY
CC-38-2	1	CABLE CLAMP
2701-050	1	CARD CAGE ASSEMBLY
4-40X1/4PFHUC	1	PHIL FLAT HEAD UNDER CUT SCREW
6-32X7/16PFH	2	PHIL FLAT HEAD SCREW
TR-361	1	TRANSFORMER
10-32X1-1/2PPHSEM	3	PHIL PAN HEAD SEMS SCREW
6-32X1/2PPHSEM	4	PHIL PAN HEAD SEM SCREW
704-313A	1	PUSH ROD
10-32KEPNUT	1	KEPNUT

2701	2701-053	Tech Chassis Assembly	1
2701	Tech	Tech	1
MODEL	NEXT ASSEMBLY	NEXT PROCESS STEP	QTY
USED ON			

DO NOT SCALE THIS DRAWING

DIMENSIONAL TOLERANCES UNLESS OTHERWISE SPECIFIED

XX = ±.015 ANG. = ±1'

XXX = ±.005 FRAC. = ±1/64

SURFACE MAX. \sqrt{R}

DATE 02-Jan-02

SCALE - - - - -

TITLE Front Panel/Card Cage Chassis Assembly

DRN. *Mat*

ENG APPR. *LS*

MATERIAL

FINISH

NO. 2701-052

KEITHLEY Keithley Instruments Inc. Cleveland, Ohio 44139

2701-053

ON

LTR	ECA NO.	REVISION	ENG	DATE
A	27327	Released	ST	6/12/02
A1	27535	2701-100C Was Rev B	ST	9/10/02
A2	27551	2701-100C1 Was Rev C	ST	9/21/02
A3	27568	2701-100C2 Was Rev C1	ST	10/21/02
A4	27687	2701-100C3 Was Rev C2	ST	11/5/02
A5	27849	2701-100 Was 2701-100C3	ST	1/2/03

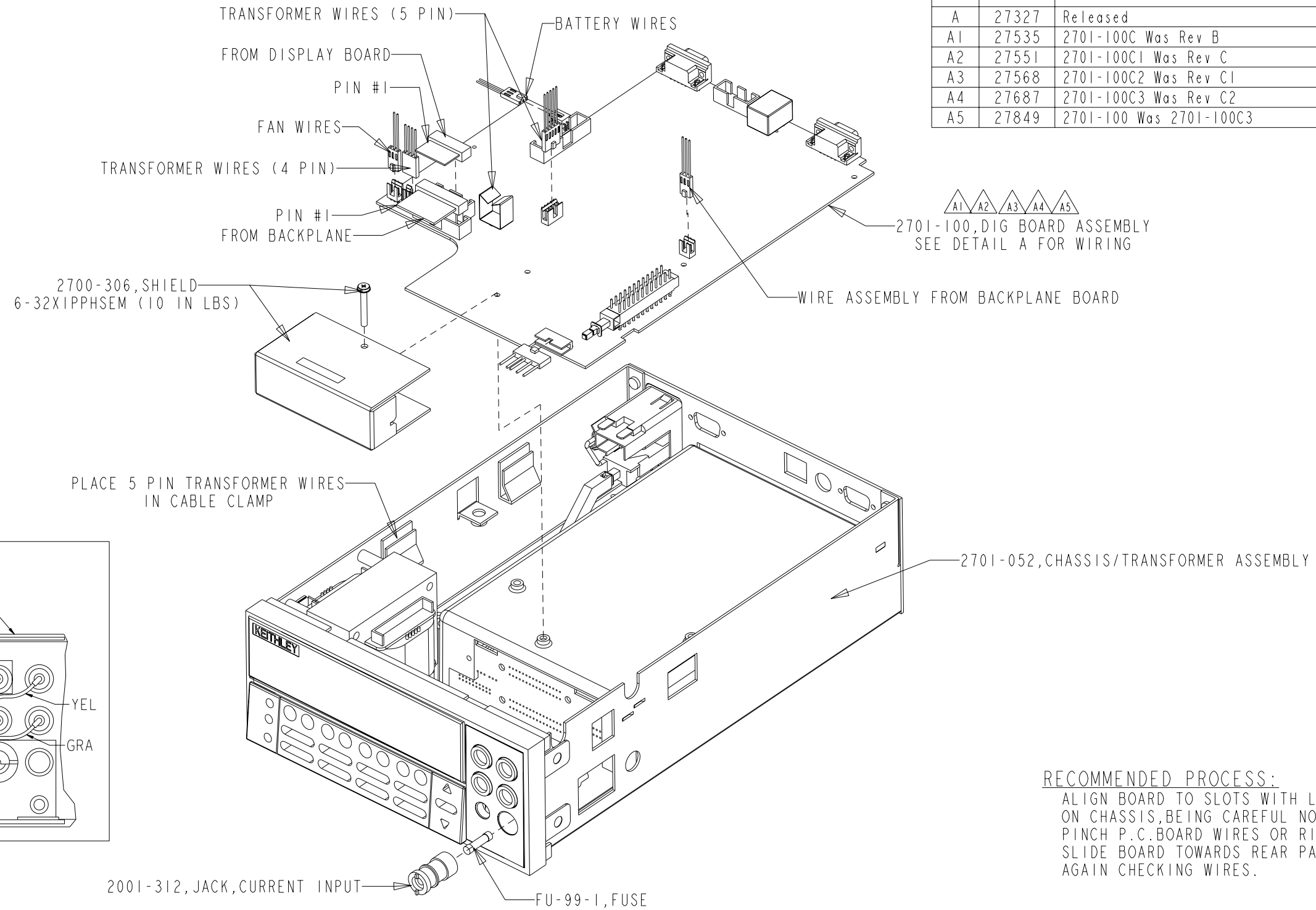

DETAIL A BJ WIRING (FRONT PANEL)

REF: FRONT PANEL

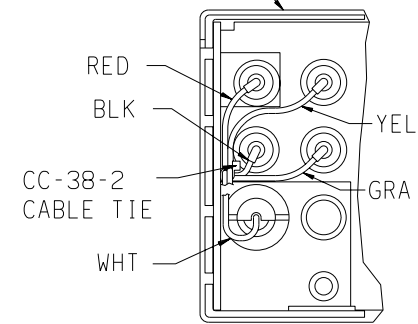

RECOMMENDED PROCESS:

ALIGN BOARD TO SLOTS WITH LANCES ON CHASSIS, BEING CAREFUL NOT TO PINCH P.C. BOARD WIRES OR RIBBON CABLE. SLIDE BOARD TOWARDS REAR PANEL, AGAIN CHECKING WIRES.

PART NUMBER	QTY	DESCRIPTION
2701-052	1	FP/CARD CAGE ASSEMBLY
$\Delta_{A4} \Delta_{A5}$ 2701-100	1	DIG BOARD ASSEMBLY $\Delta_{A1} \Delta_{A2} \Delta_{A3}$
2700-306	1	SHIELD
2001-312	1	JACK, CURRENT INPUT
FU-99-1	1	FUSE, 3 AMP
6-32X1PPHSEM	1	PHIL PAN HEAD SEMS SCREW
CC-38-2	1	CABLE TIE

2701	2701-054	Chassis Assembly	1
MODEL	NEXT ASSEMBLY	NEXT PROCESS STEP	QTY
USED ON			

DO NOT SCALE THIS DRAWING		DIMENSIONAL TOLERANCES UNLESS OTHERWISE SPECIFIED		DATE 05-Jan-02	SCALE - - - - -	TITLE	
Keithley Instruments Inc. Cleveland, Ohio 44139 CONFIDENTIAL PROPRIETARY		XX = $\pm .015$	ANG. = $\pm 1^\circ$	DRN. <i>Mat</i>	ENG APPR. <i>LS</i>	Tech Chassis Assembly	
		XXX = $\pm .005$	FRAC. = $\pm 1/64$	MATERIAL		B	NO. 2701-053
SURFACE MAX. $\sqrt{63}$		FINISH					

2701-054

ON

LTR	ECA NO.	REVISION	ENG	DATE
A	27327	Released	ST	6/12/02

BEFORE INSTALLING COVER, REMOVE PAPER FROM TOP OF BEEPER ON BOARD AND CHECK ALL WIRE CONNECTIONS. THEN POWER UP UNIT TO LOOK AT FAN TO SEE IF OPERATIONAL

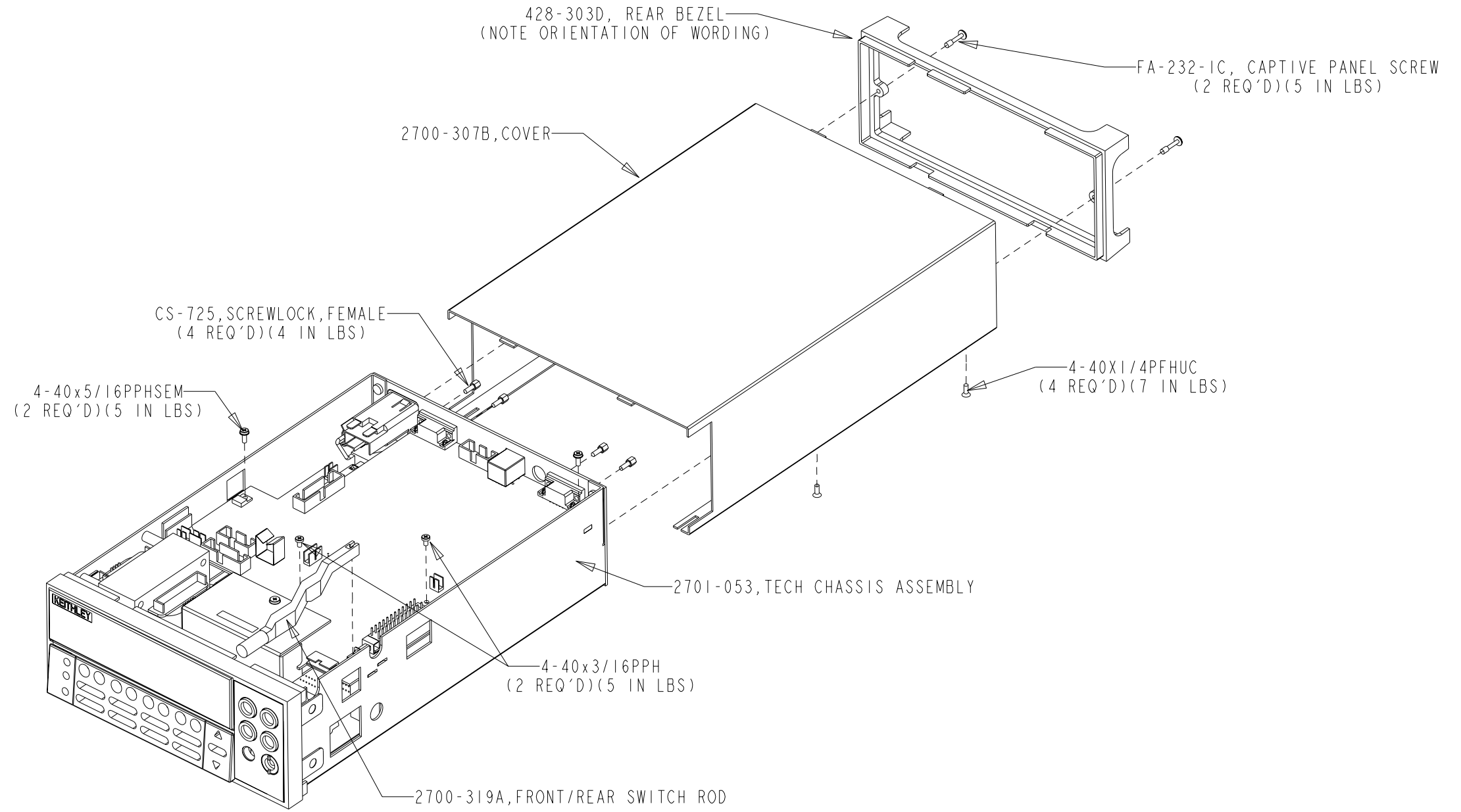

DETAIL A SW ROD ASS'Y
SEE RECOMMENDED PROCESS

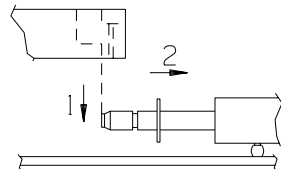

RECOMMENDED PROCESS
DEPRESS SWITCH ON DIGITAL BOARD.
SEE DETAIL A
1) ALIGN OPENING IN BOTTOM OF ROD OVER SWITCH SHAFT AND EASE ROD DOWN.
2) PUSH ROD COMPLETELY ONTO SWITCH SHAFT.
WIRE SHOULD NOT BE WRAPPED AROUND PUSH ROD

PART NUMBER	QTY	DESCRIPTION
2701-053	1	TECH CHASSIS ASSEMBLY
2700-307B	1	COVER
4-40x1/4PFHUC	4	PHIL FLAT HEAD UNDERCUT SCREW
428-303D	1	REAR BEZEL
FA-232-1C	2	CAPTIVE PANEL SCREW
CS-725	4	SCREWLOCK, FEMALE
4-40x3/16PPH	2	PHIL PAN HEAD SCREW
4-40x5/16PPHSEM	2	PHIL PAN HEAD SEMS SCREW
2700-319A	1	FRONT/REAR SWITCH ROD

2701	2701-055	Final Chassis Assembly	1
2701	Tech	Tech	1
MODEL	NEXT ASSEMBLY	NEXT PROCESS STEP	QTY
USED ON			

DO NOT SCALE THIS DRAWING		DIMENSIONAL TOLERANCES UNLESS OTHERWISE SPECIFIED		DATE 05-Jan-02	SCALE - - - - -	TITLE	
Keithley Instruments Inc. Cleveland, Ohio 44139		XX = ±.015	ANG. = ±°	DRN. <i>Mat</i>	ENG APPR. <i>LS</i>	Chassis Assembly OP6	
		XXX = ±.005	FRAC. = ±1/64	MATERIAL		B	NO. 2701-054
SURFACE MAX. $\sqrt{}$		FINISH					

080-10LZ

ON

LTR	ECA NO.	REVISION	ENG	DATE
B	27559	DEL PA-805; ADD 2701-904-00	ST	9/4/02

RECOMMENDED PROCEDURE
BEEPER INTENSITY TEST:
 1) TURN UNIT ON. LISTEN FOR BEEP.
 2) VERIFY READINGS ARE:
 LOADING FPGA
 LOAD ETHRNET
 LOADING MAIN
 DISPLAYS ALL SEGMENTS
 ETHRNET
 XXX.XXX.XXX.XXX
 1:NONE 2:NONE
 XXX XXXX

STEP 1

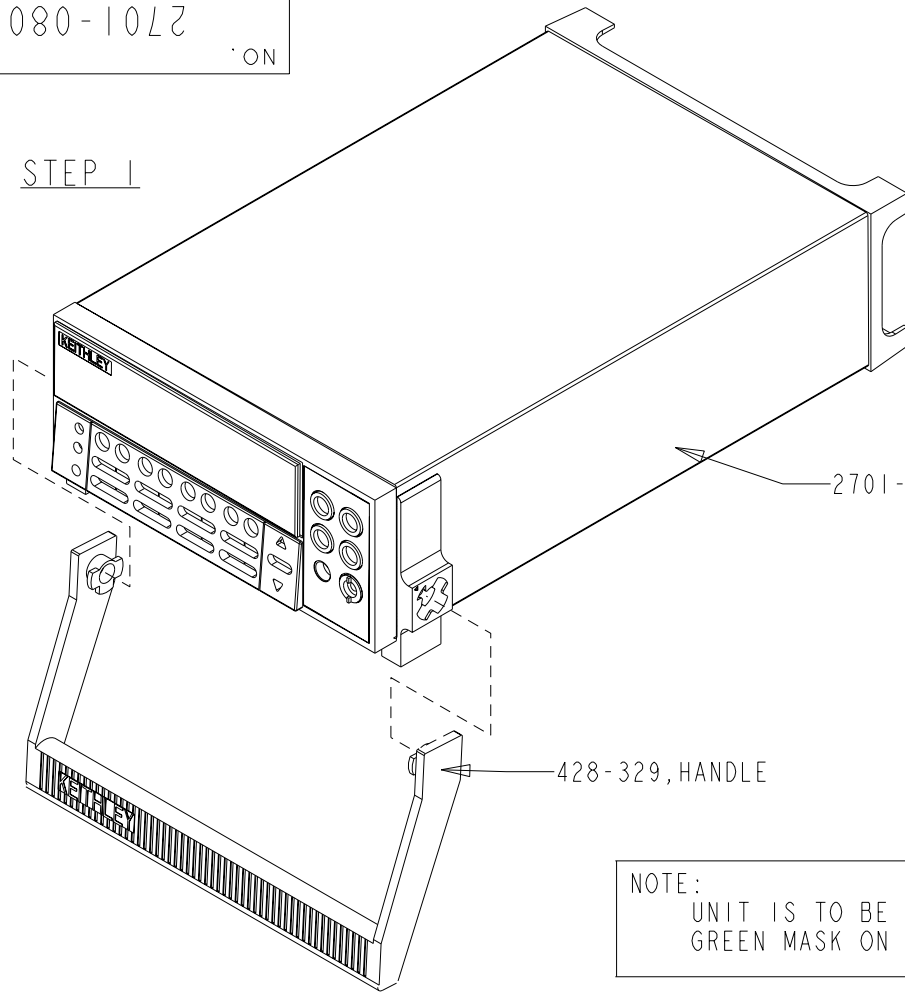

NOTE:
 UNIT IS TO BE SHIPPED WITH
 GREEN MASK ON THE LENS

PLACE CERTIFICATE OF CALIBRATION ON TOP OF UNIT, THEN PLACE INTO PO-14-4,
 CHIPLOC BAG AND SEND WITH W.O. SHIPPING KIT ITEMS TO AUDIT

CALL STOCKROOM FOR WORK ORDER
 SHIPPING KIT BEFORE SENDING TO AUDIT

STEP 2

2750-321, SLOT COVER
 4-40X1/4PPH
 (2 REQ'D)(5 IN LBS)

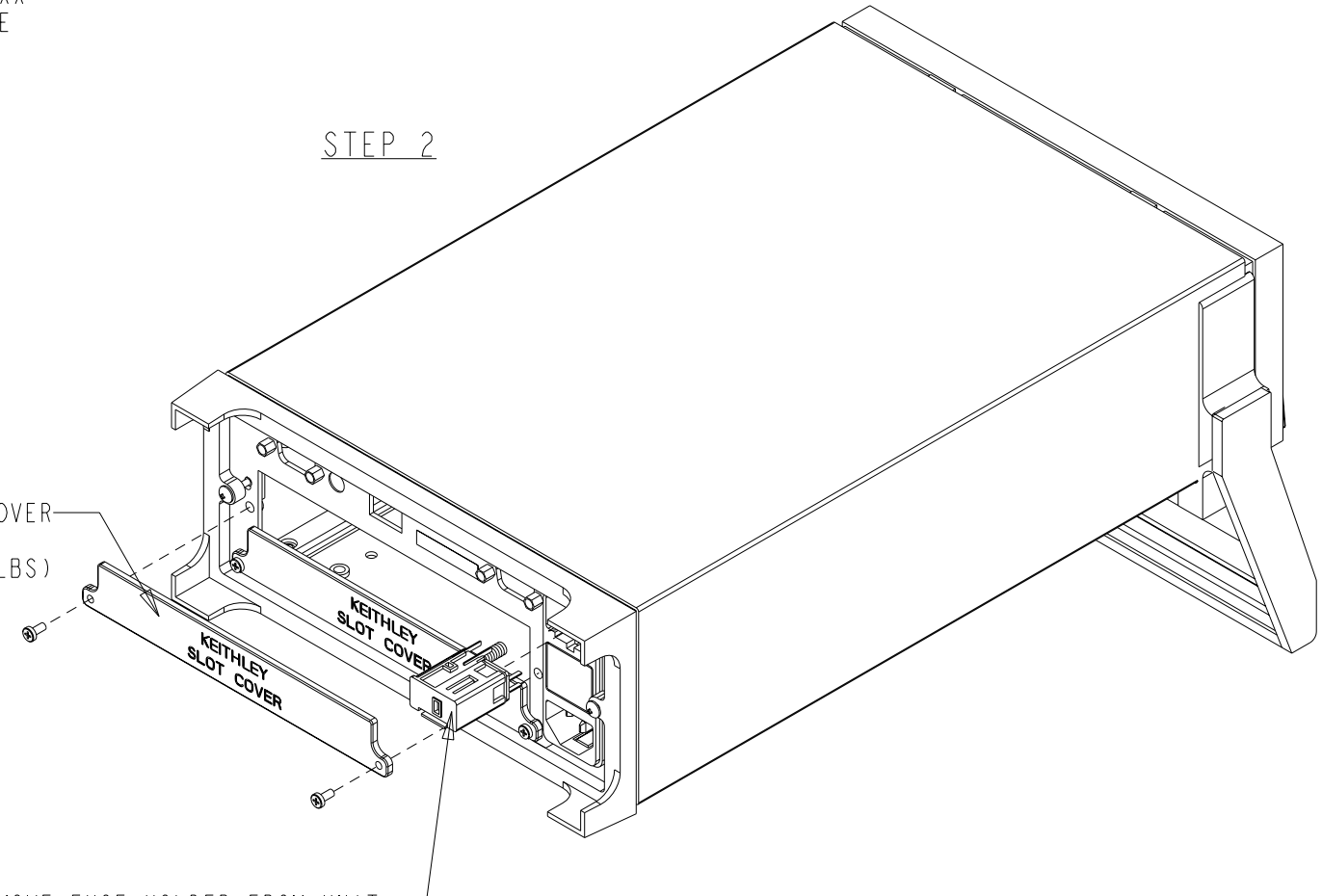

REMOVE FUSE HOLDER FROM UNIT
 PULL FUSE BLOCK SECTION OUT
 AND ROTATE UNTIL PROPER
 VOLTAGES WILL BE SHOWN IN WINDOW

PERFORM HIPOT TEST
 PER MS-1537 TO IEC
 VOLTAGE SPEC

VOLTAGE	FUSE
JAPAN 100V	EXISTING FUSE
DOMESTIC 120V	
EUROPE 220V	FU-106-.315
----- 240V	

PART NUMBER	QTY	DESCRIPTION
2701-055	1	CHASSIS ASSEMBLY
PO-14-4	1	CHIPLOC BAG
CA-180-3	1	CABLE - W.O. SHIPPING KIT
DMM-950-00*	1	CD MANUAL PACKAGE - W.O. SHIPPING KIT
PA-804	1	PACKING LIST - W.O. SHIPPING KIT
PA-854	1	PACKING LIST - W.O. SHIPPING KIT
CO-7	1	LINE CORD - W.O. SHIPPING KIT
CA-22	1	TEST LEADS - W.O. SHIPPING KIT
-----	1	CERT. OF CAL - (PA-214 PRINTED IN PROD)
4-40X1/4PPH	2	PHIL PAN HEAD SCREW
2750-321	1	SLOT COVER
428-329	1	HANDLE
Δ 2701-904-00*	1	MANUAL PACKAGE - W.O. SHIPPING KIT
2700-851	1	SOFTWARE - W.O. SHIPPING KIT
FOR EUROPE		
FU-106-.315	1	FUSE
CO-26	1	LINE CORD
FOR JAPAN		
CO-35	1	LINE CORD

2701	Audit	Audit	1
MODEL	NEXT ASSEMBLY	NEXT PROCESS STEP	QTY
USED ON			

DO NOT SCALE THIS DRAWING

DIMENSIONAL TOLERANCES UNLESS OTHERWISE SPECIFIED

XX = ±.015 ANG. = ±1°

XXX = ±.005 FRAC. = ±1/64

SURFACE MAX. \sqrt{R}

DATE 09-Jan-02 SCALE - - - - - TITLE Final Inspection

DRN. *Mat* ENG APPR. *LS*

MATERIAL FINISH

NO. 2701-080

KEITHLEY Keithley Instruments Inc. Cleveland, Ohio 44139

Replaceable parts

In this section:

Introduction	6-1
Ordering information	6-1
Factory service.....	6-1
Component layouts	6-2

Introduction

This section contains replacement parts information and component layout drawings for the 2701 and 7700.

Ordering information

To place an order or to obtain information concerning replacement parts, contact your Keithley Instruments representative or the factory. See the rear cover of this manual for contact information. When ordering parts, be sure to include the following information:

- Instrument model number (2701)
- Instrument serial number
- Part description
- Component designation (if applicable)

Factory service

If the instrument is to be returned to Keithley Instruments for repair, perform the following:

- Call the Repair Department at 1-800-935-5595 for a Return Material Authorization (RMA) number.
- Complete the service form at the back of this manual and include it with the instrument.
- Carefully pack the instrument in its original packing carton.
- Write ATTENTION REPAIR DEPARTMENT and the RMA number on the shipping label.

Component layouts

Component layouts for the various circuit boards are provided on the following pages.

PRIMARY SIDE COMPONENTS (SIDE -04)

LTR.	ECA NO.	REVISION	ENG.	DATE
B	27142	RELEASED	KEK	04/18/02
C	27408	REVISED ARTWORKS REFER TO ECA FOR PART CHANGES. CHANGED LOCATION OF MC-612 LABEL. ADDED J2 TO PTH "DO NOT POPULATE" LIST.	KEK	07/14/02
C1	27551	SEE PG.2	TJA	08/30/02

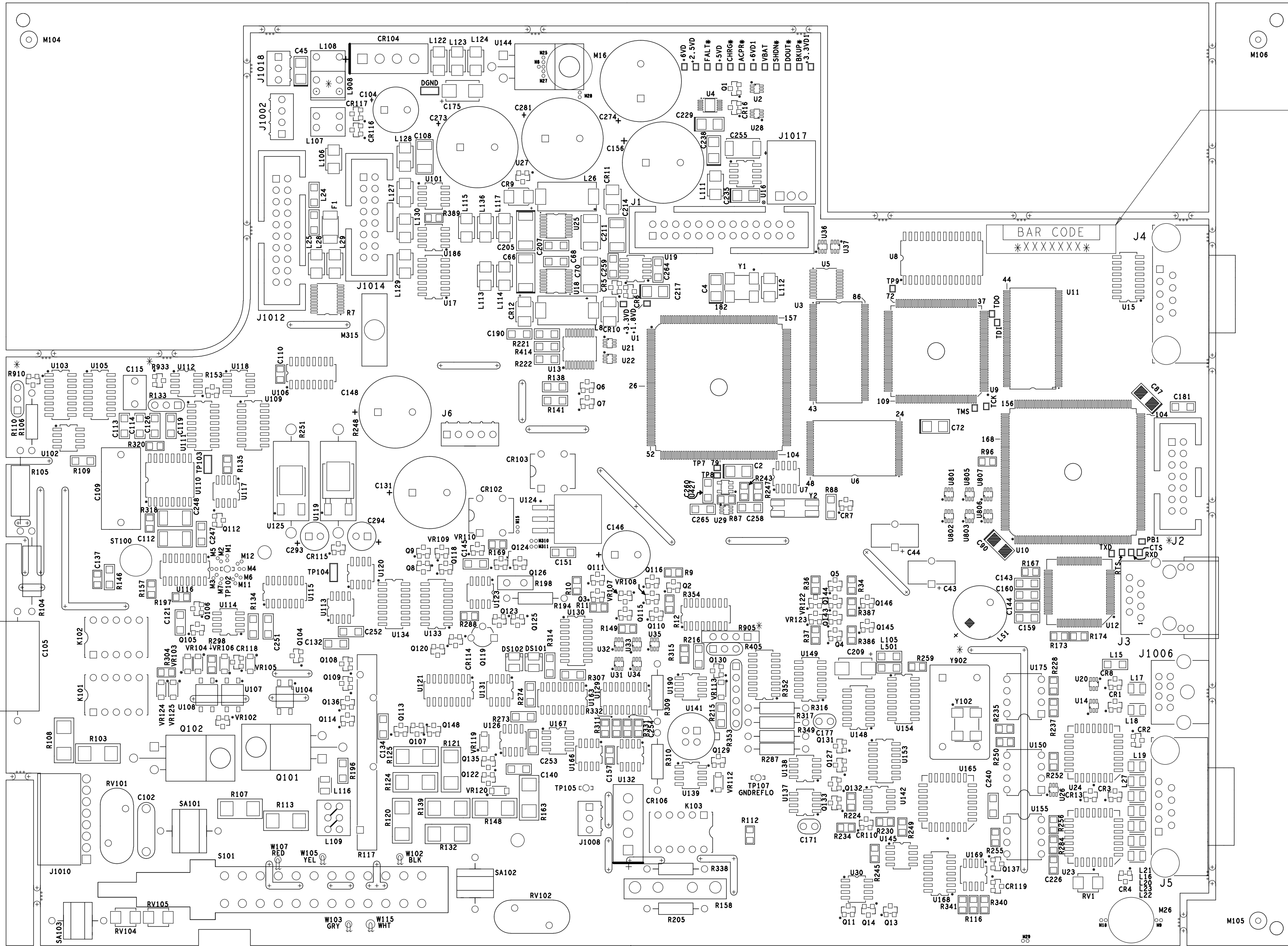

* DO NOT POPULATE:
 PTH: J2, L908, R905, Y902
 SMT: R910, R933

NOTE: FOR FURTHER COMPONENT INFORMATION,
 REFER TO PRODUCT STRUCTURE.

MODEL	NEXT ASSEMBLY	QTY.

USED ON

KEITHLEY KEITHLEY INSTRUMENTS INC. CLEVELAND, OHIO 44139	DIM ARE IN IN. UNLESS OTHERWISE NOTED	DATE 12/14/01	SCALE 3:2	TITLE COMPONENT LAYOUT, MOTHER BOARD
	DIM. TOL. UNLESS OTHERWISE SPECIFIED	DRN AJS	APPR. KAS	
XX=+.01 XXX=+.005	ANG.=+1 FRAC.=+1/64	DO NOT SCALE THIS DRAWING	C NO.	2701-100

SECONDARY SIDE COMPONENTS (SIDE -01)

LTR.	ECA NO.	REVISION	ENG.	DATE
B	27142	RELEASED	KEK	04/18/02
C	27408	REVISED ARTWORKS, REFER TO ECA FOR PART CHANGES, ADDED C69 & C208 TO SMT "DO NOT POPULATE" LIST.	KEK	07/14/02
C1	27551	CHANGED C275 FROM C-451-1000P TO C-451-22P.	TJA	08/30/02

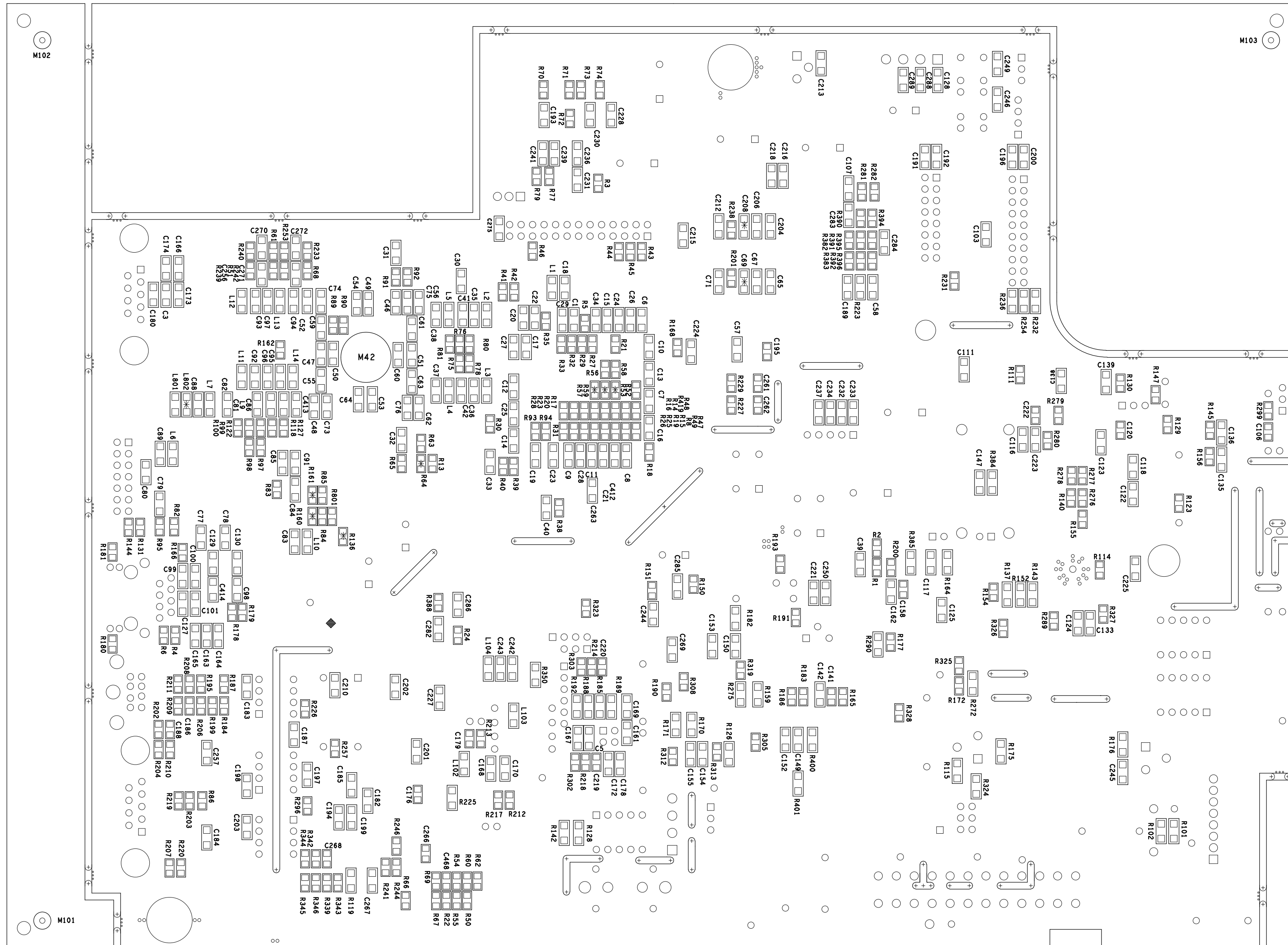

* DO NOT POPULATE:
SMT: C69, C208, L802, R53, R57, R59, R64, R136, R160, R161.

NOTE: FOR FURTHER COMPONENT INFORMATION,
REFER TO PRODUCT STRUCTURE.

MODEL	NEXT ASSEMBLY	QTY.
USED ON		

KEITHLEY KEITHLEY INSTRUMENTS INC. CLEVELAND, OHIO 44139	DIM ARE IN IN. UNLESS OTHERWISE NOTED		DATE 12/14/01	SCALE 3:2	TITLE COMPONENT LAYOUT, MOTHER BOARD
	DIM. TOL. UNLESS OTHERWISE SPECIFIED		DRN AJ5	APPR. KAS	
	XX=+.01 XXX=+.005	ANG.=+1 FRAC.=+1/64	DO NOT SCALE THIS DRAWING		C NO. 2701-100

LTR.	ECA NO.	REVISION	ENG.	DATE
H	27421	ARTWORK WAS REV G. ADDED C415-C418, R422-R426 CHG'D C414 FROM C-451-47P TO C-451-1000P.	AJS	06/26/02

PRIMARY (TOP) SIDE COMPONENTS (SIDE -02)

SECONDARY (BOTTOM) SIDE COMPONENTS (SIDE -01)

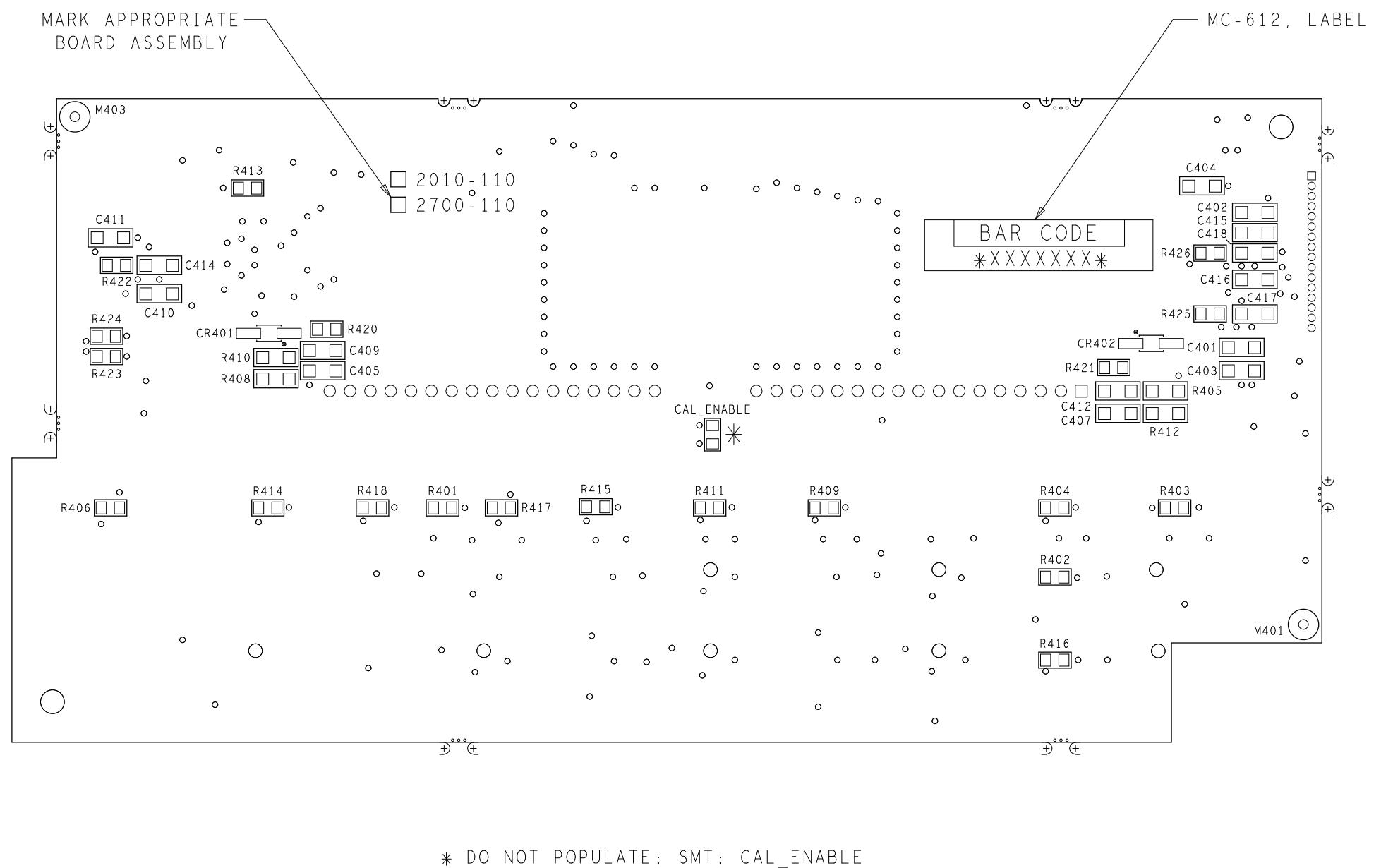
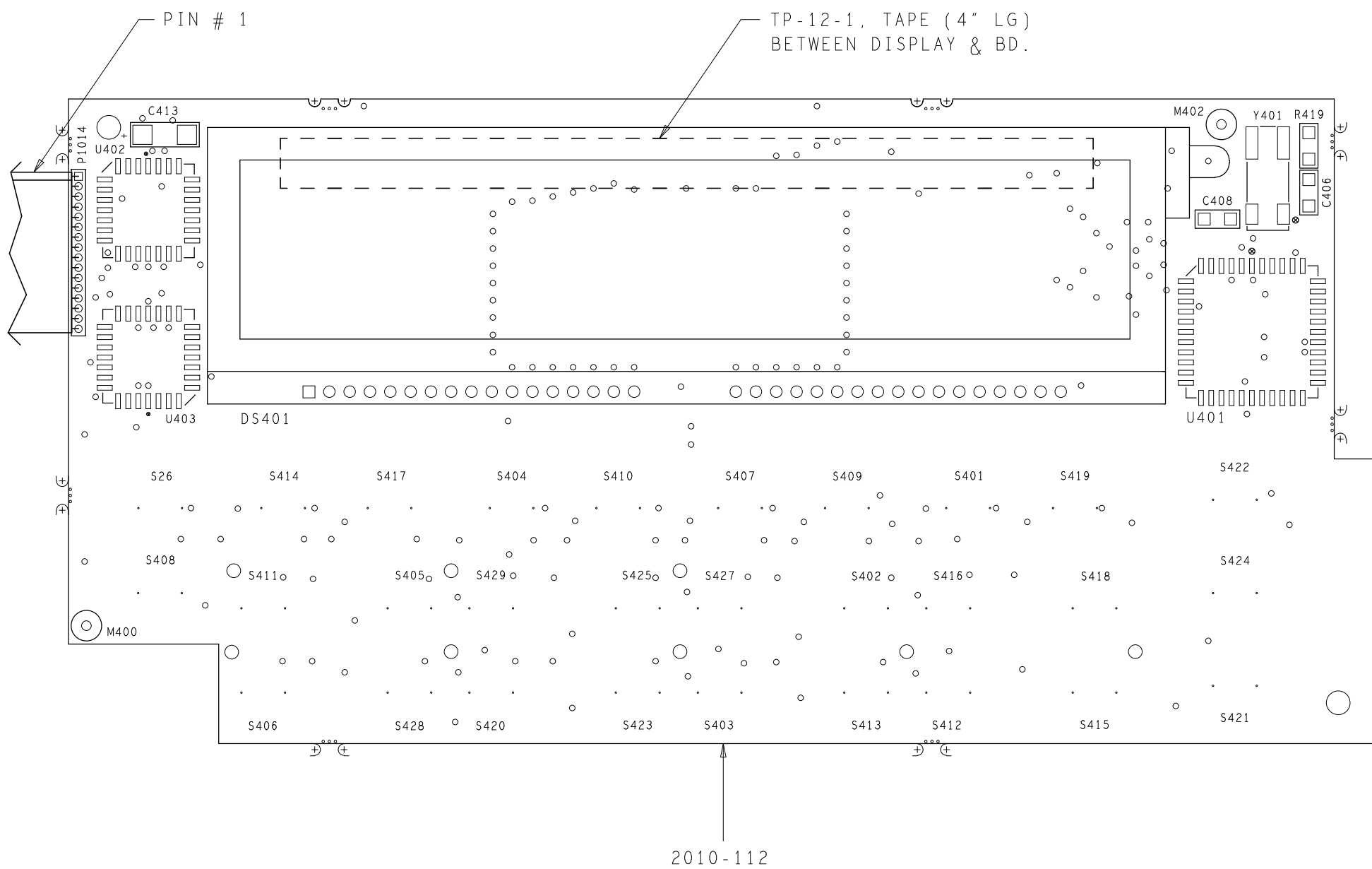

* DO NOT POPULATE: SMT: CAL_ENABLE

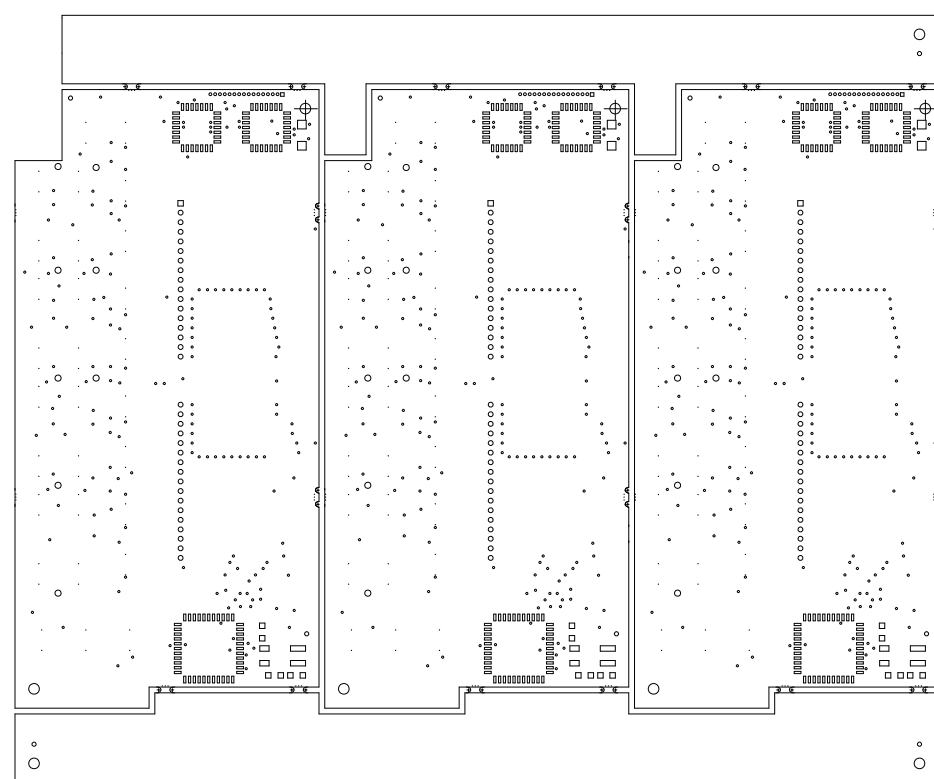

MULTI-PATTERN LAYOUT
(SCALE 1:2)
3 BOARDS PER PANEL

NOTE: FOR FURTHER COMPONENT INFORMATION, REFER TO 2700 PRODUCT STRUCTURE.

MODEL	NEXT ASSEMBLY	QTY.
USED ON		

KEITHLEY KEITHLEY INSTRUMENTS INC. CLEVELAND, OHIO 44139	DIM ARE IN IN. UNLESS OTHERWISE NOTED	DATE 07/08/00	SCALE 3:2	TITLE COMPONENT LAYOUT, DISPLAY BOARD
	DIM. TOL. UNLESS OTHERWISE SPECIFIED	DRN AJS	APPR. CJM	
	XX=+.01 XXX=+.005	ANG.=+1 FRAC.=+1/64	DO NOT SCALE THIS DRAWING	C NO.

2750-130

ON

LTR.	ECA NO.	REVISION	ENG.	DATE
A		PRELIMINARY	LM/ELS	6/5/00
B	25493	RELEASED	LM/ELS	10/26/00

PRIMARY SIDE COMPONENTS (SIDE-04)

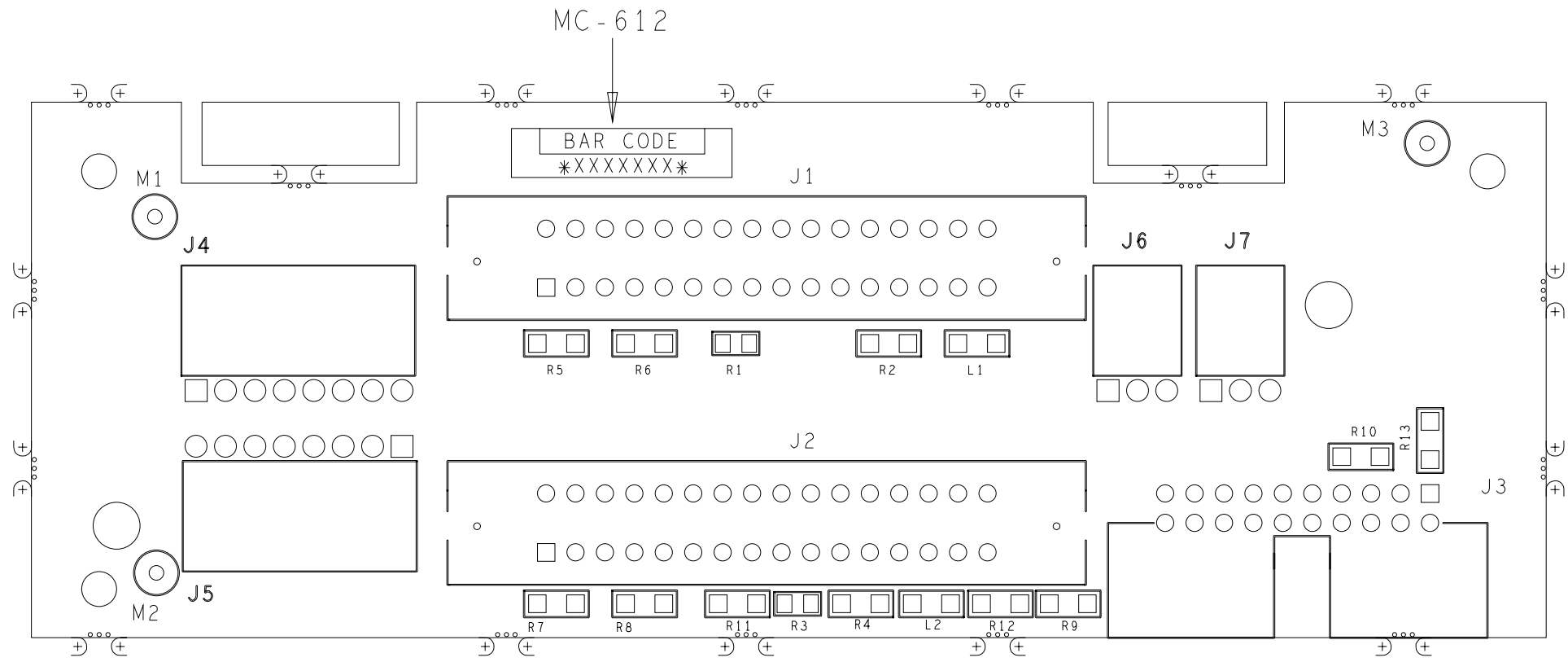

NOTE: FOR FURTHER COMPONENT INFORMATION REFER TO 2750 PRODUCT STRUCTURE.

MODEL	NEXT ASSEMBLY	QTY.
USED ON		

<p>KEITHLEY</p> <p>KEITHLEY INSTRUMENTS INC.</p> <p>CLEVELAND, OHIO 44139</p>	DIM ARE IN IN. UNLESS OTHERWISE NOTED	DATE 5/30/00	SCALE 3:2	TITLE COMPONENT LAYOUT
	DIM. TOL. UNLESS OTHERWISE SPECIFIED	DRN ELS	APPR. M.B.	
	<p>XX = +.01 ANG. = +1</p> <p>XXX = +.005 FRAC. = +1/64</p>	DO NOT SCALE THIS DRAWING		NO. 2750-130

LTR.	ECA NO.	REVISION	ENG.	DATE
A		PRELIMINARY	LM/ELS	7/27/99
B	23457	RELEASED	LM/ELS	9/15/99
B1	24351	REVISED TE'S	LM/ELS	4/20/00
B2	24159	ADDED MC-612 LABEL TO COMP L/O CHG'D REFERENCE DESIGNATORS	LM/ELS	8/15/00
B3	25075	CHG'D R1 FROM R-418-69.8K TO R-418-140K.	KEK	11/7/00
B4	27663	DRAWING NOT AFFECTED	TJA	12/13/02

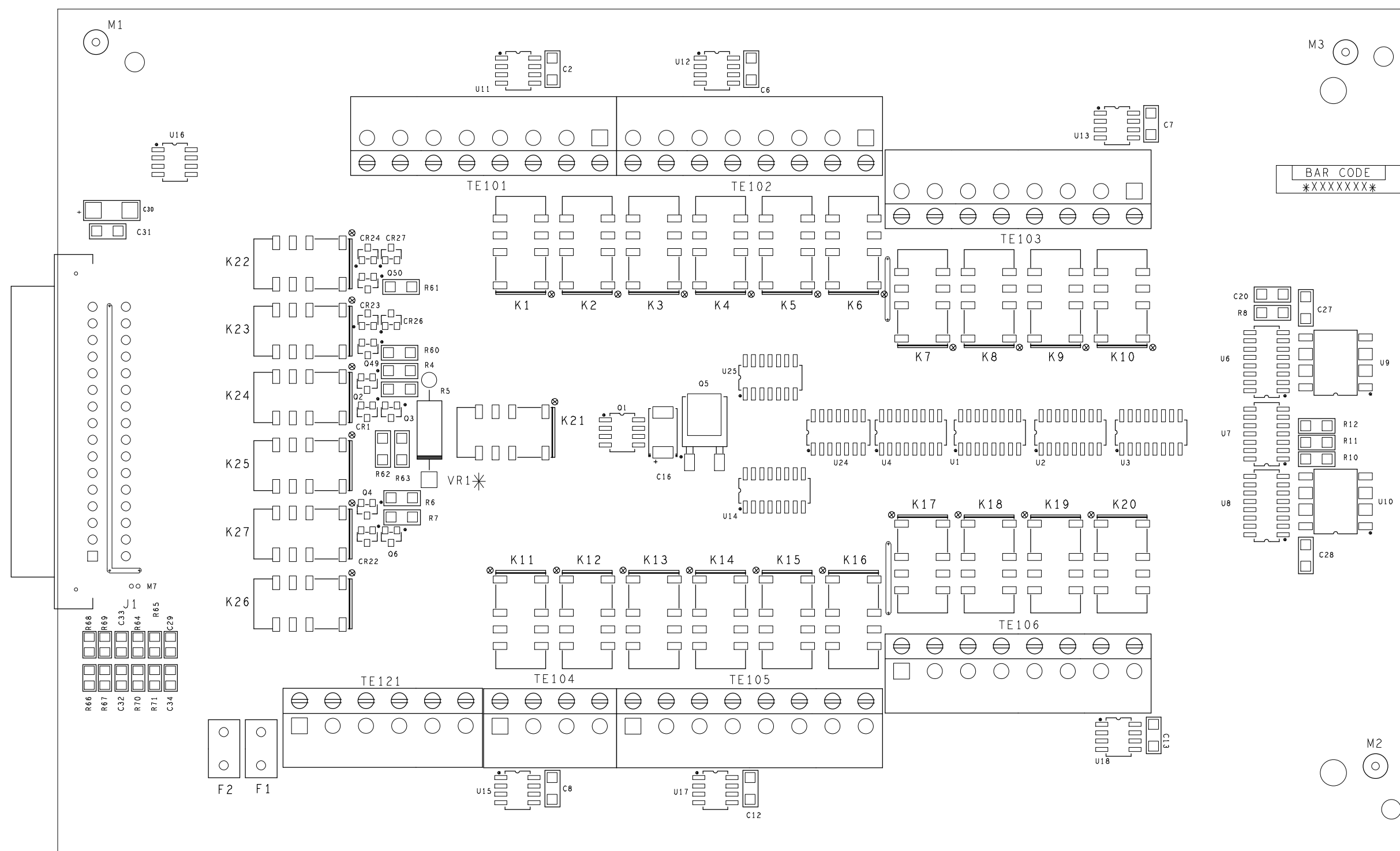

NOTE: FOR COMPONENT INFORMATION, SEE PRODUCT STRUCTURE.
PRIMARY SIDE COMPONENTS (SIDE-04)

* DO NOT POPULATE *
PTH
VR1

KEITHLEY KEITHLEY INSTRUMENTS INC. CLEVELAND, OHIO 44139 CONFIDENTIAL PROPRIETARY	UNLESS OTHERWISE SPECIFIED: DIMENSIONS ARE IN INCHES TOLERANCES: DECIMALS ANGULAR .XX ±.01 ANG. ±1° .XXX ±.005	DATE 9/15/99	SCALE 3:2	TITLE COMPONENT LAYOUT 20 CHANNEL SCANNER CARD
		DRN. ELS	APPR. P.S.	
DO NOT SCALE DRAWING			C	PG. 1 OF 2

LTR.	ECA NO.	REVISION	ENG.	DATE
A		PRELIMINARY	LM/ELS	7/27/99
B	23457	RELEASED	LM/ELS	9/15/99
B1	24351	REVISED TE'S	LM/ELS	4/20/00
B2	24159	ADDED MC-612 LABEL TO COMP L/O CHG'D REFERENCE DESIGNATORS	LM/ELS	8/15/00
B3	25075	CHG'D R1 FROM R-418-69.8K TO R-418-140K.	KEK	11/7/00
B4	27663	DRAWING NOT AFFECTED	TJA	12/13/02

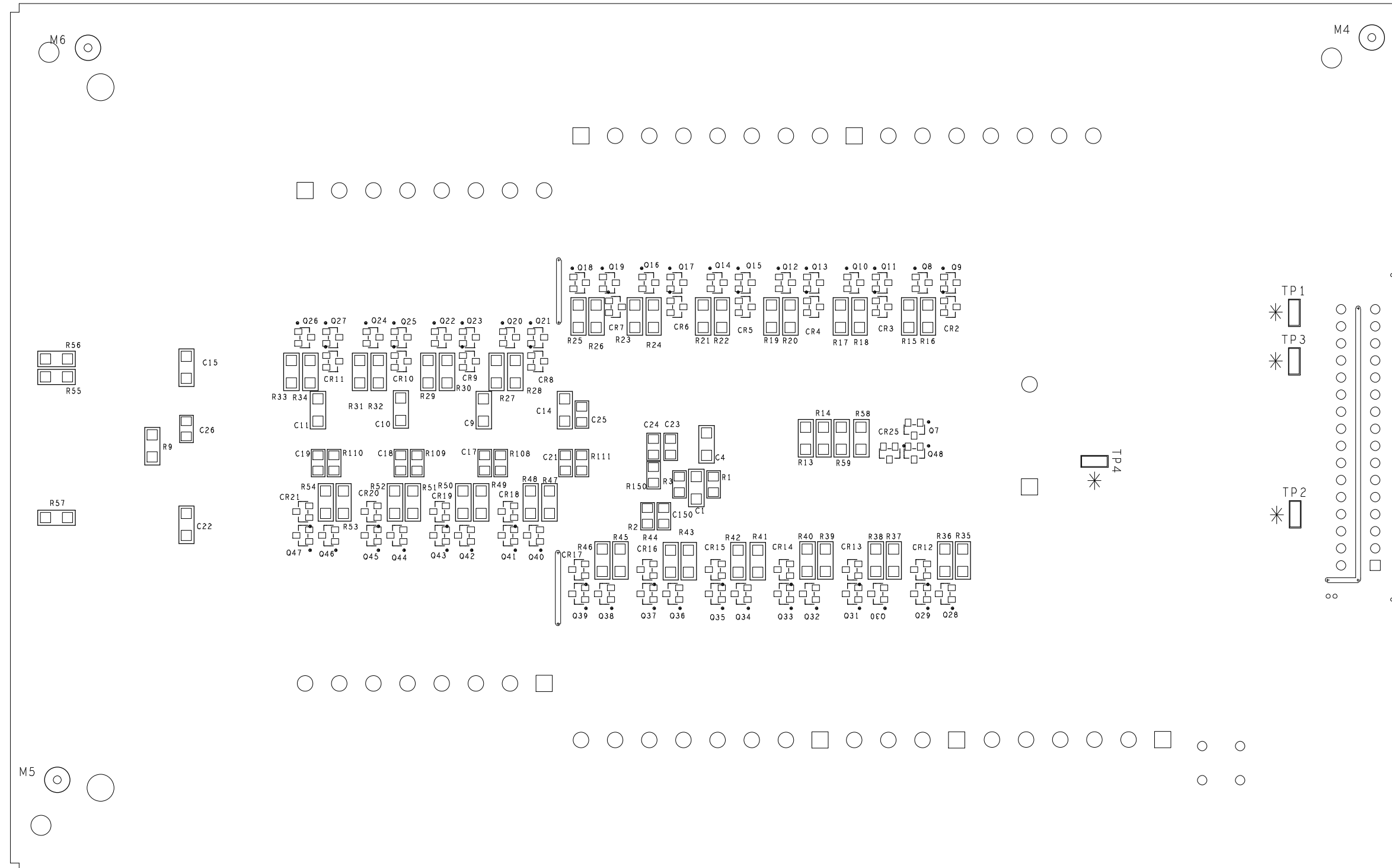

NOTE: FOR COMPONENT INFORMATION, SEE PRODUCT STRUCTURE.
SECONDARY SIDE COMPONENTS (SIDE-01)

* DO NOT POPULATE *
SMT
TP1, TP2, TP3 & TP4

 KEITHLEY INSTRUMENTS INC. CLEVELAND, OHIO 44139 CONFIDENTIAL PROPRIETARY	UNLESS OTHERWISE SPECIFIED: DIMENSIONS ARE IN INCHES TOLERANCES: DECIMALS ANGULAR .XX ±.01 ANG. ±1° .XXX ±.005 (EXCLUDES FINISHED HOLE SIZES AND BOARD LAYER CONSTRUCTION)	DATE 9/15/99	SCALE 3:2	TITLE COMPONENT LAYOUT 20 CHANNEL SCANNER CARD
		DRN. ELS	APPR. P.S.	
DO NOT SCALE DRAWING			C	NO. 7700-100

Accuracy calculations

In this section:

Introduction	7-1
Calculating DC characteristics accuracy	7-1
Calculating AC characteristics accuracy	7-2
Calculating dBm characteristics accuracy	7-2
Calculating dB characteristics accuracy	7-3
Additional derating factors	7-4
Optimizing measurement accuracy	7-4
Optimizing measurement speed	7-4

Introduction

The information in this chapter discusses how to calculate accuracy for both DC and AC characteristics.

Calculating DC characteristics accuracy

DC characteristics accuracy is calculated as follows:

Accuracy = $\pm(\text{ppm of reading} + \text{ppm of range})$

(ppm = parts per million and 10 ppm = 0.001%)

As an example of how to calculate the actual reading limits, assume that you are measuring 5 V on the 10 V range. You can compute the reading limit range from one-year DCV accuracy specifications as follows:

$$\begin{aligned}
 \text{Accuracy} = & \pm(30 \text{ ppm of reading} + 5 \text{ ppm of range}) \\
 & \pm[(30 \text{ ppm} \times 5 \text{ V}) + (5 \text{ ppm} \times 10 \text{ V})] \\
 & \pm(150 \mu\text{V} + 50 \mu\text{V}) \\
 & \pm 200 \mu\text{V}
 \end{aligned}$$

Thus, the actual reading range is: 5 V \pm 200 μ V or from 4.9998 V to 5.0002 V.

DC current and resistance calculations are performed in exactly the same manner using the pertinent specifications, ranges, and input signal values.

Calculating AC characteristics accuracy

AC characteristics accuracy is calculated similarly, except that AC specifications are given as follows:

$$\text{Accuracy} = \pm(\% \text{ of reading} + \% \text{ of range})$$

As an example of how to calculate the actual reading limits, assume that you are measuring 120 V, 60 Hz on the 750 V range. You can compute the reading limit range from ACV one-year accuracy specifications as follows:

$$\begin{aligned} \text{Accuracy} &= \pm(0.06\% \text{ of reading} + 0.03\% \text{ of range}) \\ &= \pm[(0.0006 \times 120 \text{ V}) + (0.0003 \times 750 \text{ V})] \\ &= \pm(0.072 \text{ V} + 0.225 \text{ V}) \\ &= \pm 0.297 \text{ V} \end{aligned}$$

In this case, the actual reading range is: 120 V \pm 0.297 V or from 119.703 V to 120.297 V.

AC current calculations are performed in exactly the same manner using the pertinent specifications, ranges, and input signal values.

Calculating dBm characteristics accuracy

As an example of how to calculate the actual reading limits for a 13 dBm measurement with a reference impedance of 50 Ω , assume an applied signal 0.998815 V. The relationship between voltage and dBm is as follows:

$$\text{dBm} = 10 \log \frac{V_{\text{IN}}^2}{R_{\text{REF}} \cdot 1 \text{ mW}}$$

From the previous example on calculating DC characteristics accuracy, it can be shown that a measurement of 0.998815 V on the 1 V range has an uncertainty of ± 36.9644 mV or 0.998778 V to 0.998852 V, using one-year specifications.

Expressing 0.998778 V as dBm:

$$\text{dBm} = 10 \log \frac{(0.998778 \text{ V})^2}{50 \Omega \cdot 1 \text{ mW}} = 12.99968 \text{ dBm}$$

and expressing 0.998852 V as dBm:

$$\text{dBm} = \frac{(0.998852 \text{ V})^2}{50 \Omega} = 13.00032 \text{ dBm}$$

Thus, the actual reading range is 13 dBm \pm 0.00032 dBm.

dBm and dB for other voltage inputs can be calculated in exactly the same manner using pertinent specifications, ranges, and reference impedances.

Calculating dB characteristics accuracy

The relationship between voltage and dB is as follows:

$$\text{dB} = 20 \log \frac{V_{\text{IN}}}{V_{\text{REF}}}$$

As an example of how to calculate the actual readings limits for dB, with a user-defined VREF of 10 V, you must calculate the voltage accuracy and apply it to the above equation.

To calculate a -60 dB measurement, assume 10 mV RMS for a VREF of 10 V. Using the 100 mV range, one-year, 10 Hz - 20 kHz frequency band, and SLOW rate, the voltage limits are as follows:

Accuracy = \pm [(0.06% of reading) + (0.03% of range)]

$$\pm[(0.0006 \times 10 \text{ mV}) + (0.0003 \times 100 \text{ mV})]$$

$$\pm[6 \mu\text{V} + 30 \mu\text{V}]$$

$$\pm 36 \mu\text{V}$$

Thus, the actual reading accuracy is 10 mV \pm 36 mV or 10.036 mV to 9.964 mV. Applying the voltage reading accuracy into the dB equation yields:

$$\text{dBm} = 20 \log \frac{10.036 \text{ mV}}{10 \text{ V}} = -59.96879 \text{ dB}$$

$$\text{dBm} = 20 \log \frac{9.964 \text{ mV}}{10 \text{ V}} = -60.03133 \text{ dB}$$

Thus, the actual reading accuracy is -60 dB + 0.031213 dB to -60 dB - 0.031326 dB.

dBm and dB for other voltage inputs can be calculated in exactly the same manner using pertinent specifications, ranges, and other reference voltages.

Additional derating factors

In some cases, additional derating factors must be applied to calculate certain accuracy values. For example, an additional derating factor of 0.02 ppm/V must be added to DCV specifications for voltages over 500 V. Before calculating accuracy, study the associated specifications very carefully to see if any derating factors apply.

Optimizing measurement accuracy

The configurations listed below assume that the multimeter has had factory setups restored.

DC voltage, DC current, and resistance

Select 6.5 digits, 10 PLC, filter ON (up to 100 readings), fixed range.

- Use REL on DC voltage and 2-wire resistance measurements.
- Use 4-wire resistance measurements for best accuracy.

AC voltage and AC current

Select 6.5 digits, 10 PLC, filter ON (up to 100 readings), fixed range.

Temperature

Select 6.5 digits, 10 PLC, filter ON (up to 100 readings).

Optimizing measurement speed

The configurations listed below assume that the multimeter has had factory setups restored.

DC voltage, DC current, and resistance

Select 3.5 digits, 0.01 PLC, filter OFF, fixed range.

AC voltage and AC current

Select 3.5 digits, 0.01 PLC, filter OFF, fixed range.

Temperature

Select 3.5 digits, 0.01 PLC, filter OFF.

For all functions, turn off the display and autozero, and set the trigger delay to zero. Use the `:SAMPLE:COUNT` and `READ?` bus commands.

Calibration reference

In this section:

Introduction	8-1
Command summary	8-2
Miscellaneous calibration commands.....	8-3
DC calibration commands	8-8
AC calibration commands	8-10
Manufacturing calibration commands.....	8-12
Model 7700 calibration commands.....	8-13
Remote error reporting.....	8-18
Detecting calibration step completion.....	8-21

Introduction

This appendix contains detailed information about the various 2701 remote calibration commands. For information about additional commands to control other instrument functions, refer to the *2701 User's Manual*.

Command summary

The following table summarizes the 2701 calibration commands.

Command	Description
:CALibration	Calibration root command.
:PROTeCted	All commands in this subsystem are protected by the calibration lock (except queries and :CODE).
:CODE <up to 8 char. string>	Calibration code or password (default: KI002701).
:COUnT?	Request the number of times the unit has been calibrated.
:INITiate	Initiate calibration.
:LOCK	Lock out calibration (opposite of enabling cal with :CODE command).
:LOCK?	Request comprehensive cal lock state (0 = locked; 1 = unlocked).
:SAVE	Save calibration constants to EEROM.
:DATE <year>, <month>, <day>	Send calibration date to the 2701.
:DATE?	Request calibration date from the 2701.
:NDUE <year>, <month>, <day>	Send next due calibration date to the 2701.
:NDUE?	Request next due calibration date from the 2701.
:DATA?	Request calibration constants data.
:DC	DC cal steps.
:STEP0	Rear scanner terminals short step1.
:STEP1	Front terminal short circuit.
:STEP2	Open circuit.
:STEP3 <NRf>	10 V DC step.
:STEP4 <NRf>	-10 V DC step.
:STEP5 <NRf>	100 V DC step.
:STEP6 <NRf>	1 k Ω 4-wire step.
:STEP7 <NRf>	10 k Ω 4-wire step.
:STEP8 <NRf>	100 k Ω 4-wire step.
:STEP9 <NRf>	1 M Ω 4-wire step.
:STEP10 <NRf>	10 mA DC step.
:STEP11 <NRf>	100 mA DC step.
:STEP12 <NRf>	1 A DC step.
:AC	AC cal steps.
:STEP1	10 mV AC at 1 kHz step.
:STEP2	100 mV AC at 1 kHz step.
:STEP3	100 mV AC at 50 kHz step.
:STEP4	1 V AC at 1 kHz step.
:STEP5	1 V AC at 50 kHz step.
:STEP6	10 V AC at 1 kHz step.
:STEP7	10 V AC at 50 kHz step.
:STEP8	100 V AC at 1 kHz step.
:STEP9	100 V AC at 50 kHz step.
:STEP10	700 V AC at 1 kHz step.
:STEP11	100 mA AC at 1 kHz step.

:STEP12	1 A AC at 1 kHz step.
:STEP13	2 A AC at 1 kHz step.
:STEP14	1V AC at 3 Hz step ¹ .
:STEP15	1V AC at 1kHz step ¹ .

Upper-case letters indicated short form of each command. For example, instead of sending ":CALibration:PROTeCted:INITiate," you can send ":CAL:PROT:INIT."

1. DC:STEP0, AC:STEP14, and AC:STEP15 are one-time factory calibration points and are valid only in manufacturing calibration mode.

Miscellaneous calibration commands

Miscellaneous commands perform miscellaneous calibration functions such as programming the calibration code and date. These commands are discussed in detail in the following paragraphs.

:CALibration:PROTeCted:CODE

This command changes the calibration password.

Type	Affected by	Where saved	Default value
Command only	Recall settings	Nonvolatile memory	'KI002700'

Usage

```
:CALibration:PROTeCted:CODE <string>
```

<string>	Calibration password: An 8-character string including letters and numbers
----------	---

Details

The :CODE command should be sent only once before performing either the comprehensive or factory calibration. Do not send :CODE before each calibration step.

Before changing the password, you must first enable calibration mode by using the following command:

```
:CAL:PROT:STAT ON,<password>
```

Example

:CAL:PROT:CODE '12345678'	Change the calibration password to 12345678.
---------------------------	--

Also see

None

:CALibration:PROTECTED:COUNT?

This query command returns the number of times that the instrument has completed calibration.

Type	Affected by	Where saved	Default value
Query only	Not applicable	Nonvolatile memory	Not applicable

Usage

```
:CALibration:PROTECTED:COUNT?
```

Details

Returns the number of times that the instrument has completed calibration. The calibration count will increase after saving the calibration constants.

Example

```
:CAL:PROT:COUN?
```

Return the number of times the calibration was completed.

Also see

None

:CALibration:PROTECTED:DATA?

This command queries the saved calibration constants.

Type	Affected by	Where saved	Default value
Query only	Not applicable	Nonvolatile memory	Not applicable

Usage

```
:CALibration:PROTECTED:DATA?
```

Details

This query requests all calibration constants. Values are returned in a comma-delimited ASCII string.

Example

```
:CAL:PROT:DATA?
```

Return the calibration constants.

Also see

None

:CALibration:PROTECTED:DATE

This command specifies the calibration date.

Type	Affected by	Where saved	Default value
Command and query	Not applicable	Nonvolatile memory	Not applicable

Usage

```
:CALibration:PROTECTED:DATE <year>,<month>,<day>
:CALibration:PROTECTED:DATE?
```

<year>	Year; must be more than 1970
<month>	Month: 1 to 12
<day>	Day: 1 to 31

Details

The query command returns the latest calibration date in the following format: <year> <month> <day>

Example

```
:CAL:PROT:DATE 2014, 5, 12
```

Set the calibration date to May 12, 2014.

Also see

None

:CALibration:PROTECTED:INITialize

This command starts the factory calibration procedure.

Type	Affected by	Where saved	Default value
Command only	Not applicable	Not applicable	Not applicable

Usage

```
:CALibration:PROTECTED:INITialize
```

Details

Enables calibration over the bus. You must send this command to the instrument after sending the :CODE command and before sending any other calibration command.

Example

```
:CAL:PROT:INIT
```

Start the factory calibration procedure.

Also see

None

:CALibration:PROTeCted:LOCK

This command locks calibration constants.

Type	Affected by	Where saved	Default value
Command and query	Not applicable	Nonvolatile memory	0

Usage

```
CALibration:LOCK
CALibration:LOCK?
```

Query returns	0 = Calibration unlocked 1 = Calibration locked
---------------	--

Details

Use this command to prevent comprehensive adjustment.

Send the `CALibration:PROT:LOCK?` query to determine if the calibration constants are locked. Calibration constants are locked if 1 is returned; calibration constants are unlocked if 0 is returned.

CAUTION

If you change the 2701 calibration password and forget it, you must return the 2701 to the local Keithley Worldwide Service Center to be reset. There is no user-serviceable procedure to restore the default calibration password on the 2701.

Example

<code>:CAL:PROT:LOCK</code>	Lock the calibration constants.
-----------------------------	---------------------------------

Also see

None

:CALibration:PROTeCted:NDUE

This command sends the next calibration due date to the instrument.

Type	Affected by	Where saved	Default value
Command and query	Not applicable	Nonvolatile memory	Not applicable

Usage

```
:CALibration:PROTeCted:NDUE <year>, <month>, <day>
:CALibration:PROTeCted:NDUE?
```

<year>	1999 to 2098
<month>	1 to 12
<day>	1 to 31

Details

You can store a calibration next due date in memory. Use the :NDUE? query to request the next due date. The response is in <year>, <month>, <day> format.

Example

```
:CAL:PROT:NDUE 2018, 12, 16
:CAL:PROT:NDUE?
```

Send a calibration next due date (December 16, 2018).
Request the calibration next due date.

Also see

None

:CALibration:PROTeCted:SAVE

This command saves the calibration to nonvolatile memory after the calibration procedure has been completed.

Type	Affected by	Where saved	Default value
Command only	Not applicable	Nonvolatile memory	Not applicable

Usage

```
:CALibration:PROTeCted:SAVE
```

Details

If the instrument exits the calibration mode by the following command without first saving the new constants, the previous constants are restored.

```
:CALibration:STATe OFF
```

Example

```
:CAL:PROT:SAVE
```

Save calibration constants to memory.

Also see

None

DC calibration commands

The :DC commands perform calibration of the DCV, DCI, and ohms functions. The following table summarizes these calibration commands along with the parameter limits.

Command	Description	Parameter limits
:CALibration		
:PROTECTED		
:DC		
:STEP1	Front terminal short circuit.	-
:STEP2	Open circuit.	-
:STEP3 <Nrf>	10 V DC calibration step.	9 to 11
:STEP4 <Nrf>	-10 V DC calibration step.	-9 to -11
:STEP5 <Nrf>	100 V DC calibration step.	90 to 110
:STEP6 <Nrf>	1 k Ω 4-wire calibration step.	900 to 1.1E3
:STEP7 <Nrf>	10 k Ω 4-wire calibration step.	9E3 to 11E3
:STEP8 <Nrf>	100 k Ω 4-wire calibration step.	90E3 to 110E3
:STEP9 <Nrf>	1 M Ω 4-wire calibration step.	900E3 to 1.1E6
:STEP10 <Nrf>	10 mA DC calibration step.	9E-3 to 11E-3
:STEP11 <Nrf>	100 mA DC calibration step.	90E-3 to 110E-3
:STEP12 <Nrf>	1 A DC calibration step.	0.9 to 1.1

:CALibration:PROTeCted:DC:STEP<step>

This command performs the calibration procedures.

Type	Affected by	Where saved	Default value
Command only	Not applicable	Not applicable	Not applicable

Usage

:CALibration:PROTeCted:DC:STEP<n> <value>

<n>	The step number (1 to 12)
<value>	<p>The following steps represent the entire calibration process:</p> <ul style="list-style-type: none"> ■ Step1: Front terminal short circuit calibration. ■ Step2: Open circuit calibration. ■ Step3: 10 V DC calibration (9 to 11, 10*). ■ Step4: -10 V DC calibration (-9 to -11, -10*). ■ Step5: 100 V DC calibration (90 to 110, 100*). ■ Step6: 1 kΩ 4-wire calibration (900 to 1.1E3, 1E3*). ■ Step7: 10 kΩ 4-wire calibration (9E3 to 11E3, 10E3*). ■ Step8: 100 kΩ 4-wire calibration step (90E3 to 110E3, 100E3*). ■ Step9: 1 MΩ 4-wire calibration step (900E3 to 1.1E6, 1E6*). ■ Step10: 10 mA DC calibration step (9E-3 to 11E-3, 10E-3*). ■ Step11: 100 mA DC calibration step (90E-3 to 110E-3, 100E-3*). ■ Step12: 1 A DC calibration step (0.9 to 1.1, 1*).

*Recommended value

Details

This command is used to start each calibration step. Users should follow the calibration procedure. See Example.

Example

:CAL:PROT:CODE 'KI002701'	Send the default calibration code.
:CAL:PROT:INIT	Initialize calibration.
:CAL:PROT:DC:STEP1	Perform front terminal short-circuit calibration
:CAL:PROT:DC:STEP2	Perform front terminal open-circuit calibration.
:CAL:PROT:DC:STEP3 10	Perform 10 V DC calibration with a 10 V step.
:CAL:PROT:DC:STEP4 -10	Perform -10 V DC calibration with a -10 V step.
:CAL:PROT:DC:STEP5 100	Perform 100 V DC calibration with a 100 V step.
:CAL:PROT:DC:STEP6 1E3	Perform 1 kΩ 4-wire calibration with a 1E3Ω resistance.
:CAL:PROT:DC:STEP7 10E3	Perform 10 kΩ 4-wire calibration with a 10E3Ω resistance.
:CAL:PROT:DC:STEP8 100E3	Perform 100 kΩ 4-wire calibration with a 100E3Ω resistance.
:CAL:PROT:DC:STEP9 1E6	Perform 100 MΩ 4-wire calibration with a 1E6Ω resistance.
:CAL:PROT:DC:STEP10 10E-3	Perform 10 mA DC calibration with a 10E-3 A setting.
:CAL:PROT:DC:STEP11 100E-3	Perform 100 mA DC calibration step with a 100E-3 A setting.
:CAL:PROT:DC:STEP12 1	Perform 1 A DC calibration step with a 1 A setting.
:CAL:PROT:SAVE	Save calibration constants to nonvolatile memory.

:CAL:PROT:LOCK

Lock out calibration.

Also see

None

AC calibration commands

The :AC commands perform comprehensive (user) calibration of the ACV and ACI functions. The following table summarizes these calibration commands.

Command	Description
:CALibration	
:PROTected	
:AC	
:STEP1	10 mV AC at 1 kHz calibration step.
:STEP2	100 mV AC at 1 kHz calibration step.
:STEP3	100 mV AC at 50 kHz calibration step.
:STEP4	1 V AC at 1 kHz calibration step.
:STEP5	1 V AC at 50 kHz calibration step.
:STEP6	10 V AC at 1 kHz calibration step.
:STEP7	10 V AC at 50 kHz calibration step.
:STEP8	100 V AC at 1 kHz calibration step.
:STEP9	100 V AC at 50 kHz calibration step.
:STEP10	700 V AC at 1 kHz calibration step.
:STEP11	100 mA AC at 1 kHz calibration step.
:STEP12	1 A AC at 1 kHz calibration step.
:STEP13	2 A AC at 1 kHz calibration step.

:CALibration:PROTECTED:AC:STEP<step>

This command programs the individual AC calibration steps.

Type	Affected by	Where saved	Default value
Command only	Not applicable	Not applicable	Not applicable

Usage

```
:CALibration:PROTECTED:AC:STEP<n> <value>
```

<n>	The step number (1 to 13)
<value>	<p>The following steps represent the entire AC calibration process:</p> <ul style="list-style-type: none"> ▪ Step1: 10 mV AC at 1 kHz calibration ▪ Step2: 100 mV AC at 1 kHz calibration ▪ Step3: 100 mV AC at 50 kHz calibration ▪ Step4: 1 V AC at 1 kHz calibration ▪ Step5: 1 V AC at 50 kHz calibration ▪ Step6: 10 V AC at 1 kHz calibration ▪ Step7: 10 V AC at 50 kHz calibration ▪ Step8: 100 V AC at 1 kHz calibration ▪ Step9: 100 V AC at 50 kHz calibration ▪ Step10: 700 V AC at 1 kHz calibration ▪ Step11: 100 mA AC at 1 kHz calibration ▪ Step12: 1 A AC at 1 kHz calibration ▪ Step13: 2 A AC at 1 kHz calibration

Details

This command programs the 13 individual AC calibration steps. <n> represents the STEP number. The appropriate signal must be connected to the instrument when programming each step, as summarized in the parameters.

Example

:CAL:PROT:CODE 'KI002701'	Send the default calibration code.
:CAL:PROT:INIT	Initialize calibration.
:CAL:PROT:AC:STEP1	Perform 10 mV AC at 1 kHz calibration.
:CAL:PROT:AC:STEP2	Perform 100 mV AC at 1 kHz calibration.
:CAL:PROT:AC:STEP3	Perform 100 mV AC at 50 kHz calibration.
:CAL:PROT:AC:STEP13	Perform 1 V AC at 1 kHz calibration.
:CAL:PROT:AC:STEP13	Perform 1 V AC at 50 kHz calibration.
:CAL:PROT:AC:STEP13	Perform 10 V AC at 1 kHz calibration.
:CAL:PROT:AC:STEP13	Perform 10 V AC at 50 kHz calibration.
:CAL:PROT:AC:STEP13	Perform 100 V AC at 1 kHz calibration.
:CAL:PROT:AC:STEP13	Perform 100 V AC at 50 kHz calibration.
:CAL:PROT:AC:STEP13	Perform 700 V AC at 1 kHz calibration.
:CAL:PROT:AC:STEP13	Perform 100 mA AC at 1 kHz calibration.

:CAL:PROT:AC:STEP13	Perform 1 A AC at 1 kHz calibration.
:CAL:PROT:AC:STEP13	Perform 2 A AC at 1 kHz calibration.
:CAL:PROT:SAVE	Save calibration constants to nonvolatile memory.
:CAL:PROT:LOCK	Lock out calibration.

Also see

None

Manufacturing calibration commands

The following calibration steps are performed only at the factory or when the unit has been repaired.

:CALibration:PROTECTED:AC:STEP<14|15>

This command programs individual AC manufacturing calibration steps.

Type	Affected by	Where saved	Default value
Command only	Not applicable	Not applicable	Not applicable

Usage

```
:CALibration:PROTECTED:AC:STEP14 <Cal_voltage>
:CALibration:PROTECTED:AC:STEP15 <Cal_frequency>
```

<Cal_voltage>	1 (1 V nominal)
<Cal_frequency>	1E3 (1 kHz nominal)

Details

This command performs individual AC manufacturing calibration steps. The appropriate signal must be connected to the instrument when programming each step, as summarized in the parameters.

Example

:CAL:PROT:AC:STEP14 1	Program AC calibration step 14.
:CAL:PROT:AC:STEP15 1E3	Program AC calibration step 15.

Also see

None

:CALibration:PROTECTED:DC:STEP0

This command performs rear scanner terminal short-circuit calibration.

Type	Affected by	Where saved	Default value
Command only	Not applicable	Not applicable	Not applicable

Usage

```
:CALibration:PROTECTED:DC:STEP0
```

Details

This command performs the rear scanner terminal short-circuit calibration step in the manufacturing calibration procedure. Install an extender card with low-thermal shorts on the output terminals installed in slot 1 and select the rear scanner inputs before sending this command.

Example

```
:CAL:PROT:DC:STEP0 Perform rear scanner terminal short-circuit calibration.
```

Also see

None

Model 7700 calibration commands

The following table summarizes calibration commands for the 7700 plug-in module. Note that CARD1 commands calibrate the card in slot 1, while CARD2 commands request calibration count and date information from a card in slot 2.

NOTE

A 7700 must be installed in slot 1 through a 7797 Calibration System card to be calibrated.

Command	Description
:CALibration	Calibration root command.
:PROTECTED	All commands in this subsystem are protected by the calibration lock (except queries and :CODE).
:CODE '<up to 8 char. string>'	Send calibration code. (Default is KI002701.)
:CARD1	Path to card in slot 1.
:INITiate	Initiate card calibration.
:COUNT?	Request number of times card had been calibrated.
:RCOUNT	Reset card calibration count to 0.
:DATE?	Request card calibration date.
:SAVE	Save calibration constants to card EEPROM.
:LOCK	Lock out calibration.
:LOCK?	Request calibration lock state. (0 = locked, 1 = unlocked.)
:STEP0 <Nrf>	Temperature sensor cold calibration (<Nrf> = temperature in °C).
:CARD2	Path to card in slot 2.
:COUNT?	Request number of times card has been calibrated.
:DATE?	Request card calibration date.

:CALibration:PROTECTED:CODE

This command changes the calibration password.

Type	Affected by	Where saved	Default value
Command only	Recall settings	Nonvolatile memory	'KI002700'

Usage

```
:CALibration:PROTECTED:CODE <string>
```

<string>	Calibration password: An 8-character string including letters and numbers
----------	---

Details

The :CODE command should be sent only once before performing either the comprehensive or factory calibration. Do not send :CODE before each calibration step.

Before changing the password, you must first enable calibration mode by using the following command:

```
:CAL:PROT:STAT ON, <password>
```

Example

:CAL:PROT:CODE '12345678'	Change the calibration password to 12345678.
---------------------------	--

Also see

None

:CALibration:PROTeCted:CARD1:INITiate

This query command starts the factory calibration procedure for the Model 7700.

Type	Affected by	Where saved	Default value
Query only	Not applicable	Nonvolatile memory	Not applicable

Usage

```
:CALibration:PROTeCted:CARD1:INITialize
```

Details

Enables calibration over the bus. You must send this command to the instrument after sending the :CODE command and before sending any other calibration command.

Example

```
:CAL:PROT:CARD1:INIT Begin 7700 calibration.
```

Also see

None

:CALibration:PROTeCted:CARD1:COUNT?

This query command returns the number of times that the instrument card has completed calibration.

Type	Affected by	Where saved	Default value
Query only	Not applicable	Nonvolatile memory	Not applicable

Usage

```
:CALibration:PROTeCted:CARD1:COUNT?
```

Details

Returns the number of times that 7700 card in slot 1 has completed calibration.

Example

```
:CAL:PROT:CARD1:COUNT? Return the number of times the card in slot 1 has been calibrated.
```

Also see

None

:CALibration:PROTECTED:CARD1:RCOUNT

This command resets the card calibration count reported by :COUNT? to 0.

Type	Affected by	Where saved	Default value
Command only	Not applicable	Not applicable	Not applicable

Usage

```
:CALibration:PROTECTED:CARD1:RCO
```

Details

This command resets the card calibration count reported by :COUNT? to 0.

Example

```
:CAL:PROT:CARD1:RCO
```

Reset the card calibration count.

Also see

None

:CALibration:PROTECTED:CARD1:DATE?

This command requests the card calibration date.

Type	Affected by	Where saved	Default value
Command only	Not applicable	Not applicable	Not applicable

Usage

```
:CALibration:PROTECTED:CARD1:DATE?
```

Details

These commands allow you to read back the calibration date from a 7700.

The card calibration date is automatically set to the present date of the 2701 when the card is calibrated.

Example

```
:CAL:PROT:CARD1:DATE?
```

Request the saved calibration date.

Also see

None

:CALibration:PROTeCted:CARD1:SAVE

This command saves the 7700 calibration to nonvolatile memory after the calibration procedure has been completed.

Type	Affected by	Where saved	Default value
Command only	Not applicable	Not applicable	Not applicable

Usage

```
:CALibration:PROTeCted:CARD1:SAVE
```

Details

If the instrument exits the calibration mode without first saving the new constants, the previous constants are restored.

Example

```
:CAL:PROT:CARD1:SAVE Save 7700 calibration constants to memory.
```

Also see

None

:CALibration:PROTeCted:CARD1:LOCK

This command locks out comprehensive or manufacturing calibration for the 7700.

Type	Affected by	Where saved	Default value
Command and query	Not applicable	Nonvolatile memory	0

Usage

```
:CALibration:PROTeCted:CARD1:LOCK
:CALibration:PROTeCted:CARD1:LOCK?
```

Query returns	0 = Calibration unlocked 1 = Calibration locked
---------------	--

Details

This command allows you to lock out calibration after completing the procedure.

Example

```
:CAL:PROT:CARD1:LOCK Lock the calibration constants.
```

Also see

None

:CALibration:PROTECTED:CARD1:STEP0

This command performs rear scanner terminal short-circuit calibration.

Type	Affected by	Where saved	Default value
Command only	Not applicable	Not applicable	Not applicable

Usage

```
:CALibration:PROTECTED:CARD1:STEP0 <temp>
```

<temp>	Cold calibration temperature (°C)
--------	-----------------------------------

Details

This command performs temperature sensor calibration of the 7700. Allow the card to cool to ambient temperature before you begin calibration. You must measure the cold temperature of the card and send this value as the <temp> parameter.

NOTE

Make sure to remove power to the 7700 for at least two hours to allow the card circuitry to cool. When you power on the instrument, complete the calibration as quickly as possible to minimize card heating that could affect calibration accuracy.

Example

```
:CAL:PROT:CARD1:STEP0 23
```

Perform 7700 calibration with the cold temperature of the card at 23 °C.
--

Also see

None

Remote error reporting

Methods to detect and determine the nature of calibration errors are discussed in the following paragraphs. See the *2701 User's Manual* for details on status register operation.

Error summary

The following table summarizes the 2701 calibration errors.

Error number and description
+400, "10 vdc zero error"
+401, "100 vdc zero error"
+402, "10 vdc full scale error"
+403, "-10 vdc full scale error"
+404, "100 vdc full scale error"
+405, "-100 vdc full scale error"
+406, "1k 2-w zero error"
+407, "10k 2-w zero error"
+408, "100k 2-w zero error"
+409, "10M 2-w zero error "
+410, "10M 2-w full scale error"
+411, "10M 2-w open error"
+412, "1k 4-w zero error"
+413, "10k 4-w zero error"
+414, "100k 4-w zero error"
+415, "10M 4-w sense lo zero error"
+416, "1k 4-w full scale error"
+417, "10k 4-w full scale error"
+418, "100k 4-w full scale error"
+419, "1M 4-w full scale error"
+420, "10M 4-w full scale error"
+421, "10m adc zero error"
+422, "100m adc zero error"
+423, "10m adc full scale error"
+424, "100m adc full scale error"
+425, "1 adc full scale error"
+438, "Date of calibration not set"
+439, "Next date of calibration not set"
+450, "100m vac dac error"
+451, "1 vac dac error"
+452, "10 vac dac error"
+453, "100 vac dac error"
+454, "100m vac zero error"
+455, "100m vac full scale error"
+456, "1 vac zero error"
+457, "1 vac full scale error"
+458, "1 vac noise error"
+459, "10 vac zero error"
+460, "10 vac full scale error"
+461, "10 vac noise error"

Error number and description
+462, "100 vac zero error"
+463, "100 vac full scale error"
+464, "750 vac zero error"
+465, "750 vac full scale error"
+466, "750 vac noise error"
+467, "Post filter offset error"
+468, "1 aac zero error"
+469, "1 aac full scale error"
+470, "3 aac zero error"
+471, "3 aac full scale error"
+472, "Input time constant error"
+473, "Frequency gain error"
+474, "1K Ohm loff Ocomp FS error"
+475, "10K Ohm loff Ocomp FS error"
+476, "Temperature Cold Cal error" *
+500, "Calibration data invalid"
+513, "AC calibration data lost"
+514, "DC calibration data lost"
+515, "Calibration dates lost"
+518, "Card calibration data lost" *
+519, "Card calibration dates lost" *
+610, "Questionable calibration"

*7700 card only.

Error queue

As with other 2701 errors, any calibration error will be reported in the remote error queue. You can read this queue by using the `:SYST:ERR?` query. The 2701 will respond with the appropriate error message, as summarized in the previous table.

Status byte EAV (Error Available) bit

Whenever an error is available in the error queue, the EAV (Error Available) bit (bit 2) of the status byte will be set. Use the `*STB?` query to obtain the status byte, then test bit 2 to see if it is set. If the EAV bit is set, an error has occurred and you can use the `:SYST:ERR?` query to read the error and at the same time clear the EAV bit in the status byte.

Detecting calibration step completion

When sending remote calibration commands, you must wait until the instrument completes the current operation before sending a command. You can use the `*OPC?` (operation complete) query to help determine when each calibration step is completed.

With the `*OPC?` query, the instrument will place an ASCII 1 in the output queue when it has completed each step. To use this method, allow a sufficiently long timeout period after sending each calibration command, then test for an ASCII 1 in the output queue by sending `*OPC?`.

Specifications are subject to change without notice.
All Keithley trademarks and trade names are the property of Keithley Instruments.
All other trademarks and trade names are the property of their respective companies.

Keithley Instruments
Corporate Headquarters • 28775 Aurora Road • Cleveland, Ohio 44139 • 440-248-0400 • Fax: 440-248-6168 • 1-800-935-5595 • www.tek.com/keithley

