

DMS Go+

The ultra-portable,
ultra-powerful
thickness gauge.



Featuring intuitive, easy-to-use arrow-keypad control, powerful data management and the latest industrial electronics to provide accurate, reliable and comprehensive thickness inspection data. The DMS Go+ thickness gauge that can be easily converted into a comprehensive flaw detector with a simple software upgrade.



DMS Go+

Designed and developed with the user in mind

Operational excellence

The DMS Go+ offers a comprehensive, hand-held solution to thickness measurement, data recording and data management in a wide range of applications and environments.



→ High performance thickness measurement

- Zero cross measurement technique for high measurement stability and reliability
- Automatic gain control for excellent repeatability and corrosion monitoring.
- Built-in temperature compensation for accurate measurement up to 540°C (1000°F)
- Multiple calibration and zeroing modes for repeatable accuracy.
- Multiple measurement modes, including thickness, A-scan, B-scan, Min/max and differential.

→ High capacity data recorder and compatibility with powerful data management systems

- On-board data recorder, with capacity of hundreds of thousands of thickness readings, with storage of A-scan, B-scan and MicroGrid attachments
- Data can be organized in pre-set, custom or advanced file structures.
- Data transfer is by SD card or via USB port to PC. Data can be transferred in various file formats to allow easy integration with user data management systems.
- Compatible with UltraMate and UltraMate Lite data management programs to allow for comprehensive data analysis and documentation.

→ Ease of use

- Intuitive arrow-keypad for positive digital control of parameters
- One hand operation and one-hand, menu-directed calibration process
- A "Flip" function allows use by both left-handed and right-handed operatives.
- A large, 800x480 pixel, display screen, ergonomically sized to reduce eye-strain, which can be adjusted to provide optimum visibility in various ambient light conditions.
- Small size, lightweight (870g, 1.9lb), robust construction to IP67 for operation in harsh environments.
- Battery allows up to 10 hours operation and can be re-charged on- or off-board.



A wide range of applications

The DMS Go+ is suitable for thickness measurement in a wide variety of applications throughout the industrial and process spectrum. It is especially applicable for corrosion measurement and monitoring, even on coated components and structures and at high temperatures.

Typical applications include:

Oil & Gas

- Inspection and monitoring of corrosion in tubes, vessels and tanks
- Measurement of remaining wall thickness through paint coatings

Power Generation

- Inspection of complex geometry tubes
- Monitoring of boiler efficiency by measuring oxide scale in boiler tubes with special probe OSS-10

Aerospace

- Maintenance checks

Metals Industry

- Thickness measurement of austenitic materials

Optional applications software such as TopCOAT technology, also allows measurement of coating thickness as well as metal thickness, while Auto-V measurement enables thickness to be measured on components with unknown sound velocities, without the need for a calibration block.

A simple software upgrade adds a comprehensive and versatile flaw detector to the DMS Go+

The DMS Go+ uses the same operating platform and hardware as the state-of-the-art USM Go+ portable flaw detector. This offers high Near Surface Resolution to detect flaws near to the surface, as well as a wide Pulse Repetition Frequency range, allowing it to be used for inspecting forged parts as well as welds.

An up-graded DMS Go+ means that personnel now need to carry only one instrument to perform accurate and reliable thickness measurement and flaw detection.



Technical Specifications of DSM Go+

Display	5 inch, 800 x 480 pixels, 108 x 65 mm (W x H), >200 cd/m ²
Size (W x H x D)	175 x 111 x 50 mm (W x H x D)
Weight	850 g with battery
Protection class	IP 67
Operating temperature	0 – 55 °C
Battery	Li-Ion, rechargeable, > 8 hours operation time
Power adapter / charger	100 – 240 V AC, 50/60 Hz
Probe connector	Dual Lemo-00 (T/R)
PC interface	Micro USB
Memory card	SD-Card 16 GB max
Daterecorder	100.000 readings per file. Multiple files can be stored on SD card 8 file formats, Attachment of A-Scan, B-Scan and micro grid
Pulser	120 – 250 V, Spike wave, Automatically matched to probe
Puls Repetition Frequency	4, 8 or 16 Hz selectable
Receiver	110 dB dynamic, automatic gain control, Manual -high, -low, -auto
Measurement range	0,4 – 14.000 m/s (0.01 – 551 ")
Units	mm, inch, µs
Digital Display resolution	0,01 mm or 0,1 mm (0.001" or 0.01") selectable
Measurement techniques	Zero crossing, IP to 1st echo, multi echo, TopCoat, Auto-V
Calibration	One-point, Two-point Auto or Manual On-block and Off-block Zero Automatic V-Path correction
Display mode	Thickness and A-Scan, Temperature corrected thickness, B-Scan, Min/Max capture, Differential
Compliance	EN 61010, EN 61326-1, EN 12668 ASTM E 1324, E317, ANSI/NCSL Z 540-1-1994 MIL-STD 45662A, MIL-STD 2154, EN 15317



www.ge-mcs.com

GEIT-20219EN (06/14)

GE
Sensing & Inspection Technologies

The DM5E Family of Corrosion Thickness Gauges

A Range of High Performance, Reliable and
Easy-to-Use Instruments



The DM5E family allows you to choose the functionality to suit you at a price to suit you.



GE imagination at work



New Range of High Performance Probes

A new set of ultrasonic probes has been developed for the DM5E family to provide the instruments with optimized performance, even at very high temperatures. The DA5xx series includes a 5 MHz standard probe for general purpose applications, a 2MHz version, for high penetration as well as a 7.5MHz fingertip probe. A newly developed 5MHz high temperature probe offers an operating range from -10°C up to +204°C. (Standard probes operate to 70°C)

Thickness Measurement Under Coating

Both the DM5E and the DM5E DL offer Dual Multi Measurement. Virtually all components and structures subjected to thickness measurement will have some kind of protective coating. Such coatings, including paint, contribute significant error to thickness measurements of underlying metal walls when using conventional methods. In addition, the removal of coatings, and their subsequent reapplication, involves considerable cost and time. With the field proven Dual Multi feature there is no need to remove any protective coating. It is only necessary to select Dual Multi mode, place the probe in position and take the measurement.

Flexible Data Processing

The DM5E DL has a built-in datalogger, with a capacity to store up a massive 50,000 reading in grid and linear files. This makes the measurement data available for further processing. Using our UltraMATE software. Measurement data files can be transferred from the instrument to a PC, where they can be stored and, if required, printed out in different fixed format reports. Typically, these can be colour histograms, where ranges of measured values are colour-coded, or colour can be used to highlight the distribution of minimum/maximum limit values exceeded. Data can also be pasted into Windows Clipboard for easy transfer into spreadsheet and word processing applications.

A Range of Measurement Displays

All versions of the DM5E offer a range of measurement displays.

These include:

- **Normal:** the thickness value appears as large digits in the centre of the display.
- **MIN Scan:** a minimum thickness scan that allows the user to run the probe over the wall surface. After the evaluation period, the minimum material thickness measured is displayed.
- **MAX Scan:** a maximum thickness scan which is exactly the same as a MIN Scan apart from the fact that the maximum thickness measured is displayed.
- **DIFF/RR%:** compares the measured thickness with a user-specified nominal thickness. The dimensional difference between the two values is displayed, as is the percentage difference.
- **B-Scan:** displays a graphic representation of a B-Scan showing minimum thickness values. The graph is derived by measuring and recording at 1 point per second.

Technical Specifications - DM5E Family

Instrument Specifications	
Operating Principle	Ultrasonic, Pulse Echo Measurement Method
Measuring Range	Depends on Probe and Material, 0.60 mm to 508 mm (0.025" to 20.00") in IP to 1st BW Measurement Mode, 2.00 mm to 127.0 mm (0.079" to 5.00") in Dual-Multi Measurement Mode, the Coating Thickness Range Shall be 0.3 mm to 2.50 mm (0" to 0.098").
Measuring Resolution	0.01 mm Default - Selectable 0.01, 0.1 mm (0.001" Default - Selectable 0.001, 0.01")
Material Velocity Range	0.508 to 18.699 mm/msec (0.0200 to 0.7362"/msec)
Material Velocity Resolution	1 m/s (0.0001"/msec)
Units	Inch or Millimeter
Calibration	One-Point Cal, On-Block and Off-Block, Two-Point Cal
Pulser	Excitation Pulse Spike Pulser Voltage 120 V into 50 ohm Load, Using 20 MHz Oscilloscope
Receiver	Bandwidth 500KHz to 12 MHz @ -3 dB Gain Automatic Gain Control
Display Type	High-Resolution Graphical LCD, 64 x 128 Pixels, 53.0 mm x 27.0 mm with Backlight and Adjustable Contrast
Update Rate	4 Hz or 8 Hz, User Selectable, 24 Hz Scan Mode Capture Rate
Thickness Value Display	NORMAL View Mode 5 Digit, 10.6 mm (0.4") High B-SCAN View Mode 5 Digit, 2.55 mm (0.1") High
Display of Last Reading	Solid Filled or Hollow Digits Indicate Coupled or Uncoupled Condition
Setups	9 Standard Setups for Probes
Alarm Settings	Minimum and Maximum Alarms, Range of 0.25 mm to 508 mm, 0. (0.010" to 20.00") Reading Alternates Between Solid and Hollow When Alarms Are Enabled and Violated
Power Requirements	2 "AA" Size Batteries
Battery Life/Operating Time	Approximately 60 Hours
Instrument Shut-Off	Selectable ALWAYS ON or AUTO OFF After 5, 10, 15, 30 Minutes of Inactivity
Language	Selectable English, German, French, Spanish, Italian, Russian, Japanese and Chinese
I/O Connectors	Transducer Dual Lemo 00 (coax) Mini-USB Mini-USB to PC
Temperature	Operating -10°C to +50°C (+10°F to +120°F) Storage -20°C to +60°C (-10°F to +140°F)
Weight	223 g (0.597 lb) Including Batteries
Size	138 mm x 32 mm x 75 mm
Shock	IEC 68-2-27 Ea, as per Mil Std 810C Method 516.2 Procedure I with a 15g 11ms Impulse Half Sinusoidal Wave Applied 6 Times per Axis
Sealing	IEC529 / IP54, Dust Proof/Dripping Water Proof as per IEC 529 Specifications for IP54 Classification

Data Recorder Option Features	
Capacity	50,000 Readings
File Structures	Grid File
Number of Rows	1 to 50,000
Number of Columns	1 to 223
File Naming	Up to 24 Character Alphanumeric Name
Optional Software	UltraMATE and UltraMATE Lite

DM5E Probe/Transducer Specifications				
	Model DA501	Model DA503	Model DA512	Model DA590
Frequency	5 MHz	2 MHz	7.5 MHz	5 MHz
Probe Style	Standard	Standard	Fingertip	High-Temperature
Operating Temperature Range (continuous)	-20 to 70°C	-20 to 70°C	-20 to 70°C	-20 to 204°C
Contact Diameter	15 mm (0.590")	20 mm (0.787")	7.5 mm (0.300")	12.7 mm (0.500")
IP to First Measurement Range	1.0 to 200 mm (0.040 to 8")	5 to 300 mm (0.200 to 12")	0.6 to 60 mm (0.020 to 2.4")	1 to 125 mm @20°C (0.040 to 5" @68°F) 1.3 to 25.4 mm @204°C (0.050 to 1" @400°F)
Minimum Multi-Echo Measurement Range	3.0 to 100 mm (0.118 to 3.936")	10 to 150 mm (0.393 to 5.905")	3.0 to 25 mm (0.118 to 0.984")	N/A

Note: Instrument specifications are subject to change without prior notice.



www.gesensinginspection.com

GEIT-20210

GE
Sensing & Inspection Technologies

Thickness Probes

Ultrasonic Testing





TC-560



DM-401/DM-411



FH2E-D



FH2E-WR



DA-303



DP-104



HT-400/400A



DA-312



DA312B29 and DA312B16

Application and Description	Model	Probe Cable
TopCOAT and AUTO-V with DMS 2 TC only	TC-560	KBA-531A/531TC
General purpose/side mount connector	DM-401-GP*	KBA-533/533A
General purpose/same as DM-401 only with remote send key on top of probe	DM-401-GP-REM*	KBA-533/533A
General purpose/same as DM-401 only with connectors on top	DM-411-GP*	DA-233
Pit detection and limited access/small diameter fingertip	FH2E-M	Potted
PIT detection and limited access/fingertip	FH2E	Potted
PIT detection and limited access/fingertip	FH2E-D*	Potted
Same as FH2E only with remote send key on top of probe	FH2E-D-REM*	Potted
Wear resistant case/same as FH2E	FH2E-WR	Potted
Wear resistant case/same as FH2E-D	FH2E-D-WR*	Potted
Limited access/fingertip/right angle x-talk barrier	FH2E-RA	Potted
Limited access/fingertip/right angle x-talk barrier	FH2E-D-RA*	Potted
Penetration/side mount connector	DA-303	KBA-533/533A
High penetration side mount connector	DP-104	KBA-532
High temp/for use with DM4 family of instruments	HT-400***	KBA-535/536
High temp/for use with DMS family of instruments	HT-400A***	KBA-535/536
Thin wall and small radius/square fingertip case/with removable cable	DA-312	KBA-532
Thin wall external pitting access/small diameter fingertip	KBA-525	Potted
Thin wall external pitting access/small diameter fingertip	DA-312B16**	Potted
External pitting access/small tip pencil style body	DA-312B29**	Potted
4-inch extension tube for HT-400	ET-103	
7-inch extension tube for HT-400	ET-104	
Steel bell housing for HT-400	BH-342	

*DIALOG Intelligent Probes when used with DM4E, DM4, DM4 DL or DMS 2

**2-PT calibration required on DM4E, DM4, and DM4 DL

***Temp cycled per GE instruction/limited measurement range

Contact Diameter	Frequency	Measuring Range in Steel	Temperature Range
.625 in (15.9 mm)	5	Metal : .060-8.00 in (1.5-200 mm) Coating: .002-0.80 in (0.5-2 mm)	<130°F (< 54°C)
.700 in (17.8 mm)	5	.060-8.0 in (1.5-200 mm) DM4 Dual-Multi 0.120-0.800 in (3-20 mm)	<300°F (<148°C)
.700 in (17.8 mm)	5	.060-8.0 in (1.5-200 mm) DM4 Dual-Multi 0.120-0.800 in (3-20 mm)	<300°F (<148°C)
.700 in (17.8 mm)	5	.060-8.0 in (1.5-200 mm) DM4 Dual-Multi 0.120-0.800 in (3-20 mm)	<300°F (<148°C)
.280 in (7.1 mm)	7.5	.030-1.0 in (.75-25 mm)	<130°F (<54°C)
.380 in (9.6 mm)	7.5	.030-2.0 in (.75-50 mm)	<130°F (<54°C)
.380 in (9.6 mm)	7.5	.030-2.0 in (.75-50 mm)	<130°F (<54°C)
.380 in (9.6 mm)	7.5	.030-2.0 in (.75-50 mm)	<130°F (<54°C)
.550 in (14 mm)	7.5	.030-2.0 in (.75-50 mm)	<130°F (<54°C)
.550 in (14 mm)	7.5	.030-2.0 in (.75-50 mm)	<130°F (<54°C)
.380 in (9.6 mm)	7.5	.030-2.0 in (.75-50 mm)	<130°F (<54°C)
.380 in (9.6 mm)	7.5	.030-2.0 in (.75-50 mm)	<130°F (<54°C)
.650 in (16 mm)	2	.200-12.00 in (5-300 mm)	<140°F (<54°C)
1.25 in (31.8 mm)	1	.200 in (5 mm) minimum	<130°F (<54°C)
.550 in (12.7 mm)	5	.040-10.0 in (1.0-25 mm)	<1000°F (<540°C)
.550 in (12.7 mm)	5	.040-10.0 in (1.0-25 mm)	<1000°F (<540°C)
.300 in (7.5 mm)	10	.025-2.0 in (.6-50 mm) DM4 Dual-Multi .080-0.500 in (2-12 mm)	<140°F (<60°C)
.200 in (5 mm)	10	.025-1.0 in (.6-25 mm)	<130°F (<54°C)
.120 in (3 mm)	10	.030-0.500 in (.7-12 mm)	<140°F (<60°C)
.120 in (3 mm)	10	.030-0.500 in (.7-12 mm)	<140°F (<60°C)

Specifications are subject to change without notice.

Probes to Meet all Demanding Applications

GE offers a complete line of dual element probes compatible with its D-Meter line of ultrasonic thickness gauges (DMS and DM4 family). Standard probes are readily available to satisfy a wide range of remaining wall thickness applications, including high-temperature, throughcoating, erosion/corrosion, thin materials, areas of limited access, tough-to-penetrate materials (coarse grained/non-metals), external pitting, wear-resistance, boiler tubing, small diameter piping/tubing, and most all general purpose applications.

DIALOG Intelligent Probes are automatically recognized by the DM4 or DMS 2 family of instruments for quick setup, best performance and test documentation.

If standard probes will not satisfy your requirements, our applications lab is fully equipped and staffed to offer practical solutions to your special application needs. Special probes are quoted, developed and delivered on a timely basis directly through the applications lab.

Cables and Connections



Cable	Code	Length
KBA-533	A --- A	1.2 m (4 ft)
KBA-534	A --- C	1.2 m (4 ft)
DA 233	A --- B	1.2 m (4 ft)
KBA 535	A --- E	1.2 m (4 ft)
KBA 536	A --- D	1.2 m (4 ft)
KBA 531A	A --- F	1.2 m (4 ft)

Couplants and Calibration Blocks

Name	Type	Descriptions
Exosen	General Purpose Fluid	Water soluble, non-toxic and non-flammable, Exosen is available in five standard viscosities: Exosen 10, 14, 20, 30 and 40.
Hitempco	Ambient to High Temp	Medium viscosity paste in 2 oz tube. Temperature range up to 500°F (260°C).
ZGM	High-temperature coupling paste	High viscosity paste, with solid filling, specially made for wall thickness measurements on hot parts; temperature range: +200°C to +600°C (+392°F to +1112°F); in 100g tubes.
SLC-70	Thick, Irregular Surface	Highly attenuative paste (honey consistency) in 4 oz jar.
B-320	4-Step Carbon Steel Step Block	Steps at .25 in, .50 in, .75 in and 1.0 in
B-310	5-Step Carbon Steel Step Block	Steps at .100 in, .200 in, .300 in, .400 in and .500 in
B-004	2-Step Check Block	0.100 and 1.00 Block (303 stainless steel—not certified)



www.geinspectiontechnologies.com/en

GEIT-20056EN (08/08)



With a thickness gauge in one hand and your ultrasonic transducer in the other, did you ever wish you had an extra hand?

Introducing the **StressTel PocketMIKE™** general purpose thickness gauge. The **PocketMIKE™**'s integrated product design combines the instrument and transducer into a single package not much larger than a traditional cabled probe allowing for true single hand operation.

The **PocketMIKE™** thickness gauge is packaged in a machined stainless steel housing environmentally sealed to IP67.

Four button operation and Automatic On-Block Probe Zero further support StressTel's goal of providing very capable yet simple to use instruments.

The high contrast backlit display can be mechanically and electronically rotated for ease of reading in any orientation.



Single hand operation
Waterproof to IP67/IEAC529

It's That Simple!

PocketMIKE™ SPECIFICATIONS

Kit Includes

Instrument
Wrist Lanyard
One 1.5V AA Alkaline Battery
Hard Shell Carry Case
Integrated Transducer
Couplant
Operating Manual
Certificate of Calibration



- 1 Power Key
- 2 Increase value within CAL or SETUP
- 3 Decrease value within CAL or SETUP
- 4 SETUP key to change operating modes
- 5 Initiates CAL function
- 6 Backlight Status indicator
- 7 Coupling indicator
- 8 Thickness Mode indicator
- 9 Velocity Mode indicator
- 10 CAL Mode indicator
- 11 Metric or Imperial Units
- 12 Battery Control

Special Features

Integrated Transducer, 5 MHz
True Single Hand Operation
Machined Stainless Steel Housing
Environmentally Sealed to IP67/IEC529
Automatic On-Block Probe Zero
Automatic Timed Shutoff
Auto Backlight Mode
Known Thickness Calibration
Known Velocity Calibration
4 Button Sealed Membrane Keypad
User Selectable Measurement Units
Exchangeable Probes



* Material and application dependent
Specifications subject to change without notice

Physical Size

100 mm High (4 inches)
35 mm Nominal Diameter (1.38 inches)
12 mm (0.5 inch) Probe Diameter

Weight

200 grams with Battery

Power Source

One 1.5V AA Alkaline Battery

Measuring Range*

1.0 mm to 250 mm
(0.040 inches to 9.999 inches)

Displayed Resolution

0,01 up to 99,99 mm, 0,1 above
(0.001 up to 9.999 inches, 0.01 above)

Operating Temperature

-10° C to +50° C
(14° F to 122° F)

Probe Surface Temperature

-10° C to +100° C
(14° F to 212° F)

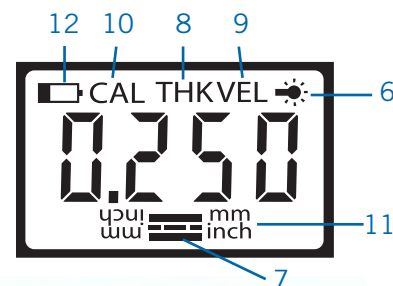

DETEK, Inc

6805 Coolridge Drive
Temple Hills, MD 20748-6940
301-449-7300 FAX 301-449-7011
www.detek.com email: sales@detek.com

STRESSTEL
part of GE Inspection Technologies

DANATRONICS

AFFORDABLE EHC-03 ULTRASONIC THICKNESS GAGE



With more than 75 years of world-wide experience in ultrasonic design, Danatronics is pleased to welcome our EHC-03 to our corrosion thickness gage family. The EHC-03 is designed to accurately and non-destructively measure metal structures subject to corrosion.

The EHC-03 is packaged in our field proven IP54 case used in our popular EHC-09 series.

The EHC-03 represents a quality, ultrasonic thickness gage designed to provide years of

unprecedented measurements all at an entry level price. With the new Q-bar, even the most inexperienced operators can quickly determine if a thickness reading is stable. The EHC-03 offers a wide measurement range, two point calibration and even multiple on-screen languages. The EHC-03 is proudly made in the U.S.A. and has a 2 year warranty. Contact Danatronics for more details.

Specifications for EHC-03:

Size: 5" (127 mm) (L) x 3" (76.2 mm) (W) x 1.25" (31.75 mm) (H)

Weight: 8 OZ (.23 kg)

Thickness range: .040"-20" (1mm-508mm) in steel

Material Velocity Calibration Range: 0.0200 - 0.7362 in/ μ S (0.508 - 18.699 mm/ μ S).

Temperature: Gage Operating: -4° F to 122° F (-20° C to 50° C)

Battery life: Up to 50 hours (20 hours with backlight on)

Battery type: 2 "AA" Alkaline

Display: 128 X 64 Graphics LCD monochrome, sunlight readable

Language support: multi language of English, French, Spanish, Italian, Czech, German, Chinese Portuguese, Slovak, Finnish, and Hungarian

Q-Bar: graphic display that confirms measurement stability

Package: IP54 rated custom, splash-proof, high impact plastic with rubber keypad

Bandwidth: 0.5-20 MHz (-3dB)

Units: English/Metric/Microseconds

Backlight: Auto on with valid reading or keypress for 10 seconds

Optional Protective pouch: Custom molded pouch with wrist strap and belt clip

Transport case: Hard plastic with high density molded foam cut out for gage and most accessories

Freeze mode: Freezes display

Hold mode: Holds display to retain last thickness reading

Standard EHC-03 includes: Ultrasonic thickness gage, DKS-537 5MHz 0.375 inch diameter potted cable, operational manual, NIST traceable calibration certificate

Note: The EHC-03 is only available with the DKS-537 and is not field upgradeable

Warranty: Limited 2 year warranty on parts and labor for gage only under normal use

Typical Applications:

- Boiler Tubes
- Pressure Vessels
- Storage Tanks
- Ship Hulls
- Containers Home
- Oil Tanks
- Pipes
- Steam Lines
- Compressor Shafts

EHC-03 Additional Features:

- Affordable hand held ultrasonic thickness gage
- Measures .040"-20" of steel
- Simple to operate
- 2 point calibration
- Q-bar to confirm measurement stability
- On screen display of multiple languages
- IP54 rated case
- Made in USA



AS EASY AS A-B-C:

EHC-09

Wave

A IS FOR A-SCAN

B IS FOR B-SCAN

AND C IS FOR COLOR DISPLAY...

IP54 RATED

- LIVE SIMULTANEOUS COLOR WAVEFORM AND THICKNESS DISPLAY
- DYNAMIC WAVEFORM COLOR CHANGE ON ALARM
- CONTROL OF GAIN, BLANKING, RANGE, RF AND RECTIFY MODES
- AVAILABLE IN MULTIPLE MODELS



With more than 75 years of world-wide experience in Ultrasonic designs, Danatronic is proud to pioneer the world's first hand held ultrasonic thickness gage with color display; our EHC09 color wave series. Unique features include live **COLOR** A-Scan, B-Scan, 100K thickness reading (3500 waveforms) datalogger with interface program, vibration and **COLOR** change of waveform on alarm.

Auto range centers echoes in the middle of the screen independent of material thickness. The blanking and gain adjustments are ideal for complete waveform adjustment and control. The echo to echo feature can ignore the paint or coating thickness. The waveform option can even be added to our popular EHC-09 gages.

TYPICAL APPLICATIONS:

- Boiler Tubes
- Pressure Vessels
- Storage Tanks
- Ship Hulls
- Containers
- Home Oil Tanks
- Pipes
- Steam lines
- Compressors
- Shafts
- Bridge Pins
- Bond Inspection

Software options are field upgradeable, there is no need to plug in a USB cable or return the unit to our factory.



6805 COOLRIDGE DR ■ TEMPLE HILLS MD 20748
301-449-7300 ■ 800-638-0554 ■ FAX 301-449-7011
EMAIL: sales@detek.com

EHC-09 | Wave

Size: 5" (127 mm) (L) x 3" (76.2 mm) (W) x 1.25" (31.75 mm) (H)

Weight: 8 OZ (.23 kg)

Thickness range: 0.020 - 20 inches (.50 mm - 508 mm) in steel, depending on material, temperature and transducer selection

Material Velocity Calibration Range: 0.0200 - 0.7362 in/ μ S (0.508 - 18.699 mm/ μ S)

Temperature: Gage Operating: -4° F to 122° F (-20° C to 50° C)
High temperature transducers available for material temperatures from -5° F to 950° F (-20° C to 510° C)

Battery life: 8 -14 hours (depends on operating conditions)

Battery type: 2 "AA" Alkaline

Color Display: 170 X 220 pixels, high resolution TFT color display, sunlight readable

Language support: multi language of English, French, Spanish, Italian, Czech, German, Portuguese, Slovak, Finnish, and Hungarian

Information displays: Loss of signal (LOS), min, max, large reading while displaying min at the same time, velocity, zero, calibration, units, freeze, unfreeze, % battery life remaining, gain - low, std, high, echo to echo symbol

Resolution: .001" (.01 mm), .01" (.1 mm)

Probe Recognition: Via pick list from a menu

Delay line zero measurement: Auto at power up with listed numeric value. Ideal for correcting delay line wear/curvature and for transducer acoustic drift at elevated temperatures

Package: IP54 Rated, Custom, splash-proof, high impact plastic with illuminating rubber keypad for go/no-go testing

Bandwidth: 0.5-20 MHz (-3dB)

Units: English/Metric/Microseconds

Gain: Low, Standard and High for varying test conditions (for gages without a waveform) or 1 dB steps from 20-90 dB or Automatic Gain Control (AGC) for gages with a waveform

Differential Mode: Displays the difference from the actual thickness measurement in absolute or percentage of a user entered reference value

Alarms: Minimum/Maximum depth, vibrates, beeps and display flashes as well as keypad illumination

Illuminating keypad: F1 = Red, F2 = Yellow and F3 = Green for easy, go/no-go testing

Ergonomics: User selectable lefty or righty display changes via keypad

Backlight: Light Emitting Diode (LED), On/Off or Auto On based on valid readings or last key press

Shut off: Auto, user programmable time out (1-31 minutes), after no reading/key press or never shut off

Protective Pouch: Custom molded pouch with belt clip and wrist strap for either lefty or righty operators (optional, standard with DLC and DLCW).

Transport case: Hard Plastic with high density molded foam cut out for gage and most accessories

Freeze mode: Freezes display (ideal for high temperature applications)

Hold mode: Holds display to retain last thickness reading

Standard EHC-09 Wave Series includes: Ultrasonic thickness gage, DKS-537, 5 MHz 0.375 inch diameter potted cable, operational manual, Data XL interface program, couplant, and transport case. See chart below for standard inclusions for each gage

Warranty: Limited 2 year warranty on parts and labor for gage only under normal use

Transducers: A wide variety of dual transducers from 1-10 mhz, high temperature duals, delay lines and pencil probes

Item	Specification	EHC-09DLCW	EHC-09DLC	EHC-09CW	EHC-09C
Thickness range:	0.020 - 20 inches (.50 mm - 508 mm) in steel	✓	✓	✓	✓
Delay line zero measurement:	Auto at power up with listed numeric value. Ideal for correcting delay line wear/curvature and for transducer acoustic drift at elevated temperatures	✓	✓	✓	✓
Scan mode:	Simultaneously displays minimum or maximum and actual thickness value at 20 measurements per second	✓	✓	✓	✓
Differential Mode:	Displays the difference from the actual thickness measurement and a user entered reference value	✓	✓	✓	✓
Alarms:	Minimum/Maximum depth, vibrates, beeps and display flashes as well as keypad illumination and vibration	✓	✓	✓	✓
Illuminating keypad:	F1 = Red, F2 = Yellow and F3 = Green for easy, go/no-go testing	✓	✓	✓	✓
Velocity Mode:	Displays acoustic sound speed	✓	✓	✓	✓
Echo to Echo:	Measures the metal thickness only (ignore paint and coatings)	✓	✓	✓	✓
Range:	Adjustment of manual range control or auto zoom tracking to center echoes independent of selected range	✓	○	✓	○
Rectification Modes:	RF, Half Wave Positive, Half Wave Negative and Full Wave Rectification	✓	○	✓	○
Live Waveform (A-scan):	Full adjustments, for gain in 1db step or AGC, main bang blank, blank after first received echo, range including zoom auto tracking to center echoes independent of material and rectification	✓	○	✓	○
B-Scan (Encoded or Non-Encoded)	Displays a cross section of the test piece with optional encoder and factory upgrade	✓	✓	○	○
Datalogger:	Upgrade to Data Logger Version, 100,000 readings in linear, 2D, 3D grid or boiler alphanumeric files, 20 character file name, file compare, grid review and export to excel via Data XL interface program, also compatible with Ultrapipe	✓	✓	○	○

○ = Software options that are field upgradeable, no need to return the unit to the factory

ECHO Series

Hand-Held Ultrasonic Thickness Gages
for Corrosion and Precision Applications



- Simple to Operate
- Hand Held
- Field Upgradeable Options
- Corrosion and Precision Modes
- Live A-scan
- Made in the USA

A Totally New Platform of Ultrasonic Thickness Gages

Our new ECHO series represents a totally new platform of ultrasonic thickness gages combining corrosion and precision gaging into one tough, small package... The perfect size of fit and function! Hold the ECHO in your hand and you will agree no detail has been overlooked and the ergonomics are unmatched by any thickness gage in the industry! The new ECHO series comes in 3 configurations; ECHO 9, ECHO 8 and ECHO 7. ECHO 9 is our corrosion gage using dual transducers, ECHO 7 is our precision gage with 1 micron resolution using single element transducers and ECHO 8 is the ultimate unit combining both dual and single element transducers.

The new ECHO series can non-destructively measure essentially any engineering material thickness. In its most popular configuration, the ECHO 9 series is an extremely capable, hand held ultrasonic thickness gage for measuring the wall thickness of primarily metal structures subject to corrosion. ECHO can easily be upgraded to precision mode to utilize single element transducers.

The ECHO series has a remarkable sunlight readable 3.5" color display, up to 32 Gb of micro SD memory, built-in rechargeable high capacity Li Ion battery all packaged in a custom case designed for IP67 rating. Not sure which model to choose? Don't worry, the ECHO series is fully capable of field upgrades directly from the keypad so you will never be stuck with an obsolete product or experience any downtime. ECHO Series can measure from .020" to 23" in steel in corrosion mode or as thin as .006" in steel when configured as a precision gage.



ECHO Series Standard Features

- Compatible with a wide variety of Danatronics and common competitor dual and single element transducers
- Change color and VIBRATE on alarm (ideal for inspections in loud environments)
- 27 Hour battery life with hi-capacity re-chargeable battery pack via the USB port
- Wide thickness range (.006" to 23" depending on gage type, material and transducer)
- Inches, mm or μ Sec
- Multiple languages
- Velocity mode
- Fast Min/Max mode to display actual thickness and minimum and maximum at the same time
- Gain, range, rectification, blank adjustments with live waveform
- Datalogger 2 Gb micro SD card standard expandable to 32 Gb
- Datalogger interfaces with Microsoft Excel
- Designed for IP67
- Made in the USA
- Simple one hand operation
- Field upgradeable software options

ECHO Series Standard Inclusions

Includes transducer (DKS537, dual 5.0 Mhz, .375" with potted 3 foot cable for corrosion gages; for precision gages, a probe up to 10 Mhz with a lemo to microdot cable are included), 2 Gb micro SD card, Li-ion battery, battery charger, transport case, manual with data XL, USB cable, echo-to-echo to ignore coatings. Our most advanced models include custom rubber boot.

Call with your ID and payment to unlock any additional features.

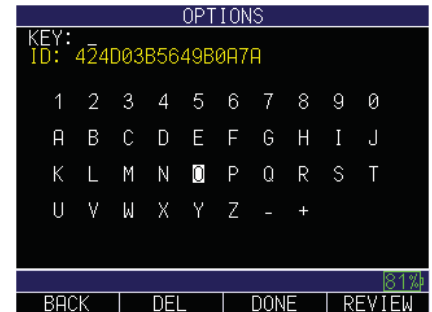

ECHO Series Software Options

Software options are all field upgradeable with many advantages:

- Options are activated via the keypad...no need to plug into a computer
- Only takes less than one minute
- No shipping cost
- No downtime
- Never worry about buying an obsolete unit
- Less initial outlay of capital

Datalogger

(includes B-scan) internally store millions of thickness readings with ID location and send readings to Microsoft Excel via our Data XL interface program.

Oxide Scale

Simultaneously displays the wall thickness of the boiler tube thickness as well as the internal oxide scale at their independent velocities. Knowing the thickness of the boiler tube can greatly improve the efficiency and extended life of the tube.

Live Waveform

Displays the live A-scan for echo verification and real time control of range, gain, rectification and blanks.

Corrosion Mode

Uses dual transducers to measure remaining wall thickness on primarily steel structures subject to corrosion.

Angle Beam Software

Available on ECHO 8 and ECHO 9, displays trig functions of detected echo for angular distance, surface and depth.

NOTE: Not meant to be a code compliant ultrasonic flaw detector due to vertical linearity and display update rate.

Precision Mode

Allows for the use of single element transducers along with up to 2,700 stored application setups with 1 micron resolution (.0001" or .001mm).

ECHO 9 Corrosion Thickness Gage

Our ECHO 9 is our premier corrosion thickness gage with a wide thickness range, able to be used with a variety of dual transducers as well as a selection of single element and angle beam probes. Similar to our precision thickness gages, ECHO 9 can save and store custom setups.

Typical Applications

- Boiler tubes
- Pressure vessels
- Storage tanks
- Ship hulls
- Pipes
- Steel beams on bridges

Standard Features

- Compatible with a wide variety of Danatronics dual and single element transducers
- Wide thickness range (.020" to 23" depending on gage type, material and transducer)
- Coating Thickness and substrate thickness displayed simultaneously on gage with live waveform
- High temperature probes available up to 950F/509C (intermittent use)
- Temperature correction
- File compare features shows old readings along with new readings for datalogger versions (real-time corrosion monitor)
- Available angle beam option



ECHO 9 – Base model includes Echo to Echo



ECHO 9W – Includes Waveform, Coating Thickness

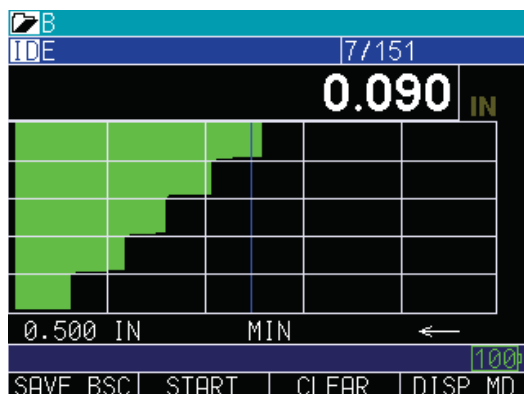

ECHO 9DL – Includes Datalogger, B-scan, Temperature Correction



ECHO 9DLW – Includes Waveform, Datalogger, B-scan, Coating Thickness, Temperature Correction

ECHO 7 Precision Thickness Gage

ECHO 7 hand-held ultrasonic thickness gages are designed for use with single element contact, delay line and immersion transducers to provide the maximum thickness range and up to 1 micron resolution. ECHO 7 can save up to 2,700 custom applications setups allowing the operator to quickly and easily switch transducers and setups on the fly for unique and separate tasks.



Standard Features

- .006-20" range in steel
- 1 micron resolution (0.0001" or 0.001 mm)
- single element, contact, delay line and immersion transducers (1-25 MHz)
- Store and recall up to 2,700 setups
- Multiple modes for challenging applications
- 30 Mhz bandwidth
- Squarewave Pulser
- Zoom Auto Tracking

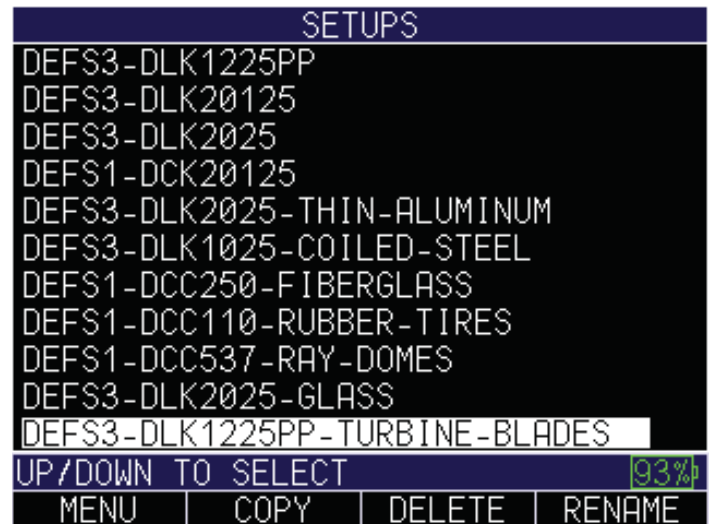

Typical Applications

- Castings
- Turbine blades
- Plastic parts including bottles, pipes, trays and toys
- Coil steel and automotive body panels
- Fiberglass and gel coatings
- Velocity verification for ductile and gray iron (Velocimeter)
- Aluminum, glass, ceramics, zinc and more



ECHO 8 Corrosion and Precision Thickness Gage

ECHO 8 represents our most capable ultrasonic thickness gage combining both dual and single element probes into one small instrument. Quickly switch transducers and “gage type” to essentially non-destructively measure any engineered material. The ECHO series can keep track of up to 2,700 stored setups, so switching from materials with different thicknesses and alarm values is simple.

Typical Applications

- Inspection Companies—all-purpose gage for measuring any engineered material thickness
- Airplane Inspection (thin aluminum, plastic windows, and rubber tires)
- Marine Surveyors (fiberglass & steel)

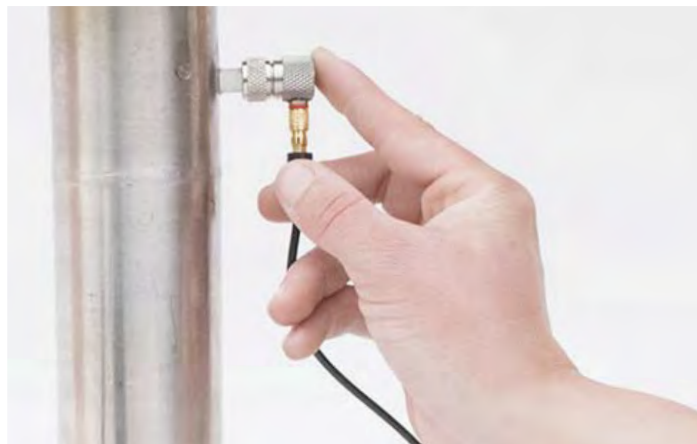

ECHO series in A and B-Scan with EZ Scan magnetic wheel encoder

Standard Features

- Includes all features from the ECHO 7 and ECHO 9
- Switch from dual to single element transducers
- Switch resolution from .01” to .001” to .0001”
- Store and recall up to 2,700 applications setups
- Rechargeable batteries good for more than 24 hr.
- ECHO 8DLW includes custom rubber boot with stand



Environmentally Tough, Ergonomically Superior!



Environmentally Tough!

The ECHO series was designed from the ground up. With more than 85 combined years in designing, manufacturing and using hand held ultrasonic thickness gages, Danatronics left no detail uncovered. From its new case designed for IP67, to its easy to read sunlight readable 3.5" color display, you will find the ECHO series combines practical features with a simple, clean design built for years of field service and durability.

Ergonomically Superior!

With its new 3.5" sunlight readable display, The ECHO series offers many display formats to suit any age operator and reduce fatigue. So whether you want to view the largest possible numbers or would prefer more text on screen, ECHO has you covered.

ECHO is also perfectly balanced and makes holding it in one hand possible and simple... no clumsy joy sticks or second functions



Easy to hold and operate in one hand

needed. There is even a world's first vibrate on alarm to inform the operator any pre-set thickness threshold has been tripped which is great for tired operators and testing in loud environments.

Hardware Options

- Rubber boot with chest harness with built-in finger strap and bail (stand)
- Magnetic wheel encoder
- Footswitch
- Remote power bank
- Magnetic pipe stand



Data XL and Data XL PRO

At Danatronics we believe managing your saved data should be simple. As such, we include with every thickness gage a free interface program we call Data XL. Data XL saves readings to .csv files that can be used in any spreadsheet program such as Microsoft Excel or Google Sheets.

Here are some advantages:

- Write custom batch programs
- Simple double click the file to be transfer and Microsoft Excel with all i.d.'s and readings are displayed
- Create file and send them to the ECHO
- Merge files using Data XL
- Saved stored application setuups can be sent to the ECHO or multiple ECHO units to ensure reliability and repeatability
- Update firmware (latest version of operating software is available on the support tab of www.danatronics.com)
- Send Bit Maps (screen shots) to further document your inspections

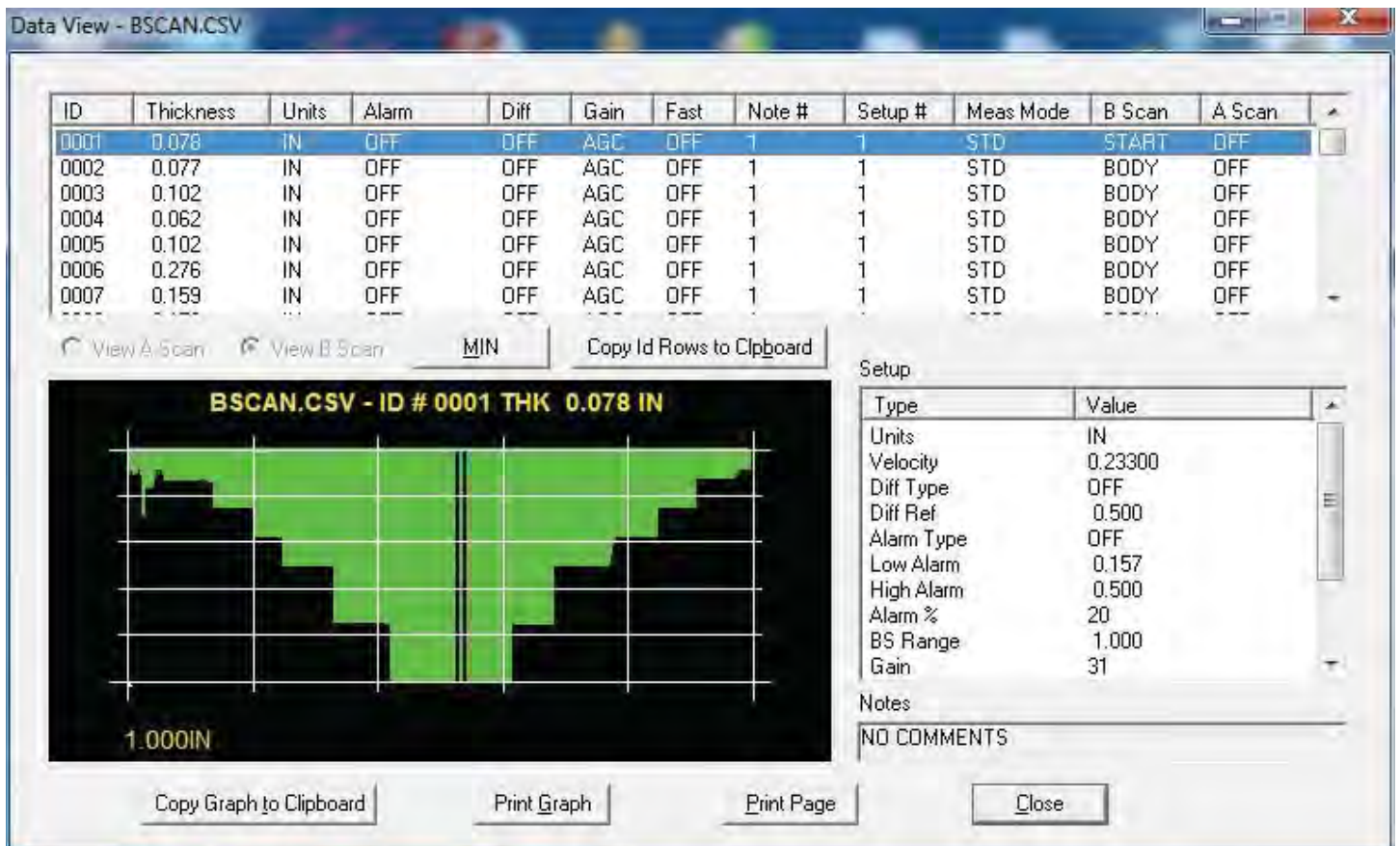
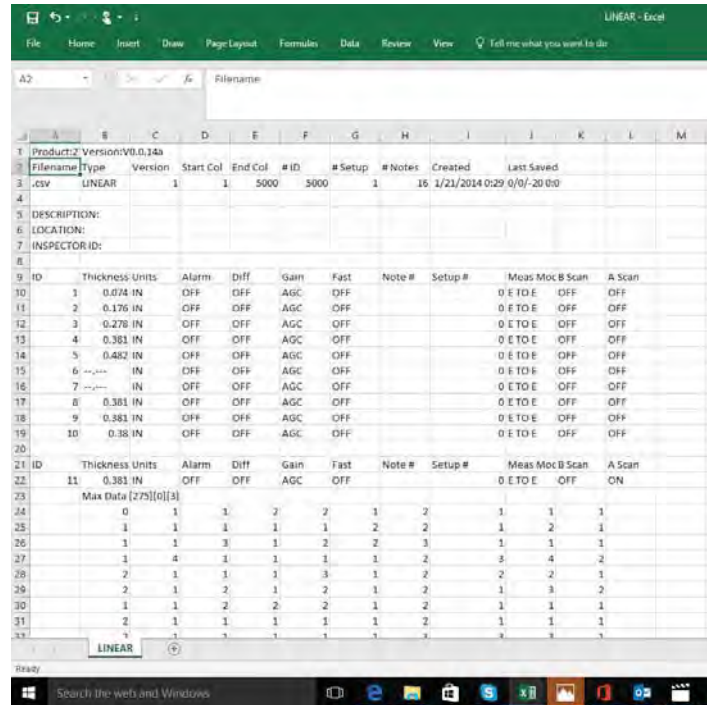

The optional Data XL Pro does all of the above plus allows the transfer of A-scan and B-scan for the ultimate in computer software reporting.

Danatronics Transducers

The ECHO series comes loaded with a default list of probes to solve a vast variety of applications for any non-destructive testing wall thickness of most engineering materials.

So, if you are measuring, boiler tubes, pressure vessels, ship hulls, bridges, coil steel, aluminum, plastic bottles, toys, trays and anything in between...we have the probe for you..

Dual Transducers

Standard Dual Transducers

ECHO Model	Part No.	Range in Steel	Echo to Echo Range in Steel	Freq.	Diameter	Temperature Range	Connector Type
8, 9	DK-250	0.100"-20" (2.5mm-508mm)	0.200"-2" (5.08mm-50.8mm)	2.25 MHz	0.500"/12.7mm	32-392F/0-200C	Right Angle Potted - Lemo 00
8, 9	DK-525	0.040"-20" (1mm-508mm)	0.080"-2" (2mm-50.8mm)	5.0 MHz	0.250"/6.35mm	32-392F/0-200C	Right Angle Potted - Lemo 00
8, 9	DK-537	0.040"-20" (1mm-508mm)	0.080"-2" (2mm-50.8mm)	5.0 MHz	0.375"/9.52mm	32-392F/0-200C	Right Angle Potted - Lemo 00
8, 9	DKS-537	0.040"-20" (1mm-508mm)	0.100"-0.750" (2.54mm-19.05mm)	5.0 MHz	0.375"/9.52mm	32-100F/0-38C	Right Angle Potted - Lemo 00
8, 9	DK-550	0.040"-20" (0.76mm-508mm)	0.080"-2" (2mm-50.8mm)	5.0 MHz	0.500"/12.7mm	32-392F/0-200C	Right Angle Potted - Lemo 00
8, 9	DK-718	0.030"-2" (0.76mm-50.8mm)	0.060"-1" (1.52mm-25.4mm)	7.5 MHz	0.187"/4.75mm	32-392F/0-200C	Right Angle Potted - Lemo 00
8, 9	DK-718LPM*	0.050"-2" (1.25mm-50.8mm)	N/A	7.5 MHz	0.187"/4.75mm	32-392F/0-200C	Right Angle Potted - Lemo 00
8, 9	DK-1025	0.020"-2" (0.5mm-50.8mm)	0.060"-1" (1.52mm-25.4mm)	10.0 MHz	0.250"/6.35mm	32-392F/0-200C	Right Angle Potted - Lemo 00

*LPM = Low Profile Mini; probe height 16mm, top dia. 12mm

Composite Dual Transducers

ECHO Model	Part No.	Range in Steel	Echo to Echo Range in Steel	Freq.	Diameter	Temperature Range	Connector Type
8, 9	DC-110	0.200"-20" (5.08mm-508mm)	Not Recommended	1.0 MHz	1"/25.4mm	10-160F/-12-70C	Right Angle Potted - Lemo 00
8, 9	DC-175	0.150"-20" (3.81mm-508mm)	Not Recommended	1.0 MHz	0.750"/19.05mm	10-160F/-12-70C	Right Angle Potted - Lemo 00
8, 9	DC-250	0.100"-20" (2.5mm-508mm)	0.200"-2" (5.08mm-50.8mm)	2.25 MHz	0.500"/12.7mm	10-160F/-12-70C	Right Angle Potted - Lemo 00
8, 9	DC-525	0.030"-20" (0.76mm-508mm)	0.080"-2" (2mm-50.8mm)	5.0 MHz	0.250"/6.35mm	10-160F/-12-70C	Right Angle Potted - Lemo 00
8, 9	DC-537	0.040"-20" (1mm-508mm)	0.080"-2" (2mm-50.8mm)	5.0 MHz	0.375"/9.52mm	10-160F/-12-70C	Right Angle Potted - Lemo 00
8, 9	DC-550	0.030"-20" (0.76mm-508mm)	0.080"-2" (2mm-50.8mm)	5.0 MHz	0.500"/12.7mm	10-160F/-12-70C	Right Angle Potted - Lemo 00

Dual Echo To Echo Transducers

ECHO Model	Part No.	Range in Steel	Echo to Echo Range in Steel	Freq.	Diameter	Temperature Range	Connector Type
8, 9	DK537EE	0.040"-20" (1mm-508mm)	0.080"-1.5" (2mm-38.1mm)	5.0 MHz	0.375"/9.52mm	31-392F/0-200C	Right Angle Potted - Lemo 00
8, 9	DK-718EE	0.030"-1.5" (0.76mm-38.1mm)	0.060"-1.0" (1.5mm-25.4mm)	7.5 MHz	0.187"/4.75mm	31-392F/0-200C	Right Angle Potted - Lemo 00

Dual High Temp Transducers

ECHO Model	Part No.	Range in Steel	Echo to Echo Range in Steel	Freq.	Diameter	Temperature Range	Connector Type
8, 9	DHT-537	0.040"-20" (1mm-508mm)	0.080"-2" (2mm-50.8mm)	5.0 MHz	0.375"/9.52mm	-5 to 950F -20 to 509C	Straight Microdot requires detachable cable
8, 9	DHT-537RM	0.040"-20" (1mm-508mm)	0.080"-2" (2mm-50.8mm)	5.0 MHz	0.375"/9.52mm	-5 to 950F -20 to 509C	Right Angle Microdot requires detachable cable

Quick Change Composite Element Angle Beam Transducers

Available in: Diameter: 1/4", 3/8" & 1/2"; Frequencies: 1.0, 2.25, 3.5, 5.0, 7.5 & 10.0 MHz; Standard Wedges: 30°, 45°, 60°, 70°



Danatronics Transducers

Contact Transducers

Standard Contact

ECHO Model	Part No.	Range in Steel Class 1	Range in Steel Class 2	Range in Steel Class 3	Range in Plastic	Freq.	Diameter	Temperature Range	Connector Type*
7, 8	DCK-250	0.100"-20" (2.54mm-508mm)	n/a	n/a	n/a	2.25 MHz	0.500" 12.7mm	32-392F 0-200C	Right Angle Microdot
7, 8	DCK-525	0.040"-20" (1mm-508mm)	n/a	n/a	n/a	5.0 MHz	0.250" 6.35mm	32-392F 0-200C	Right Angle Microdot
7, 8	DCK-537	0.040"-20" (1mm-508mm)	n/a	n/a	n/a	5.0 MHz	0.375" 9.52mm	32-392F 0-200C	Right Angle Microdot
7, 8	DCK-550	0.080"-20" (2mm - 508mm)	n/a	n/a	n/a	5.0 MHz	0.500" 12.7mm	32-392F 0-200C	Right Angle Microdot
7, 8	DCK-718	0.030"-10" (.76mm - 254mm)	n/a	n/a	n/a	7.5 MHz	0.187" 4.75mm	32-392F 0-200C	Right Angle Microdot
7, 8	DCK-1025	0.020"-2" (.5mm - 50.8mm)	n/a	n/a	n/a	10.0 MHz	0.25" 6.35mm	32-392F 0-200C	Right Angle Microdot
7, 8	DCK-1025HR	0.020"-1" (.5mm - 25.4mm)	n/a	n/a	n/a	10.0 MHz	0.25" 6.35mm	32-392F 0-200C	Right Angle Microdot
7, 8	DCK-20125	0.016"-1" (.4mm - 25.4mm)	n/a	n/a	n/a	20.0 MHz	0.125" 3.175mm	32-392F 0-200C	Right Angle Microdot

Contact Composite

ECHO Model	Part No.	Range in Steel Class 1	Range in Steel Class 2	Range in Steel Class 3	Range in Plastic	Freq.	Diameter	Temperature Range	Connector Type*
7, 8	DCC-110	0.300"-20" (7.62mm - 508mm)	n/a	n/a	n/a	1.0 MHz	1" 25.4mm	10-160F -12-70C	Right Angle Microdot
7, 8	DCC-175	0.300"-20" (7.62mm - 508mm)	n/a	n/a	n/a	1.0 MHz	0.750" 19.05mm	10-160F -12-70C	Right Angle Microdot
7, 8	DCC-250	0.100"-20" (2.54 - 508mm)	n/a	n/a	n/a	2.25.0 MHz	0.500" 12.7mm	10-160F -12-70C	Right Angle Microdot
7, 8	DCC-537	0.040"-20" (1mm-508mm)	n/a	n/a	n/a	5.0 MHz	0.375" 9.52mm	10-160F -12-70C	Right Angle Microdot

Delay Line Transducers

Delay Line Standard

ECHO Model	Part No.	Range in Steel Corrosion Mode	Range in Steel Class 2	Range in Steel Class 3	Echo to Echo Range in Steel	Range in Plastic	Freq.	Diameter	Temperature Range	Connector Type*
7, 8, 9	DLK-525	0.080"-0.750" (2mm-19mm)	0.025-0.500" (6.35mm - 12.7mm)	0.020"-0.375" (0.5mm - 9.5mm)	0.025" - 0.400" (0.635mm-10.16mm)	0.010"- 0.150" (0.254mm - 3.81mm)	5.0 MHz	0.25" 6.35mm	32-122F 0-50C	Right Angle Microdot
7, 8, 9	DLK-1025	0.080"-0.750" (2mm-19mm)	0.020"-0.500" (0.5mm - 12.7mm)	0.015"-0.375" (0.38mm - 9.5mm)	0.025" - 0.400" (0.635mm-10.16mm)	0.010"-0.150" (0.254mm - 3.81mm)	10.0 MHz	0.25" 6.35mm	32-122F 0-50C	Right Angle Microdot
7, 8, 9	DLK-1225PP-SM	0.080"-0.300" (2mm-7.62mm)	0.020"-0.200" (0.5mm - 5.08mm)	0.015"-0.125" (0.38mm - 5.08mm)	0.020" - 0.200" (0.508mm-5.08mm)	0.015"-0.060" (0.15mm - 1.52mm)	12.0 MHz	0.080" 2mm (tip dia)	32-122F 0-50C	Right Angle Microdot
7, 8, 9	DLK-1225PP-RM	0.080"-0.300" (2mm-7.62mm)	0.020"-0.200" (0.5mm - 5.08mm)	0.015"-0.125" (0.38mm - 5.08mm)	0.020" - 0.200" (0.508mm-5.08mm)	0.015"-0.060" (0.15mm - 1.52mm)	12.0 MHz	0.080" 2mm (tip dia)	32-122F 0-50C	Right Angle Microdot
7, 8	DLK-2025	n/a	0.015"-0.300" (3.81mm - 7.62mm)	0.006"-0.200" (0.152mm- 7.62mm)	n/a	0.003"-0.100" (0.076mm - 2.54mm)	20 MHz	0.25" 6.35mm	32-122F 0-50C	Right Angle Microdot
7, 8	DLK-20125	n/a	0.015"-0.200" (3.81mm - 7.62mm)	0.006"-0.200" (0.152mm- 7.62mm)	n/a	0.003"-0.100" (0.076mm - 2.54mm)	20 MHz	0.125" 3.175mm	32-122F 0-50C	Right Angle Microdot

Delay Line Composite

ECHO Model	Part No.	Range in Steel Class 1	Range in Steel Class 2	Range in Steel Class 3	Range in Plastic	Freq.	Diameter	Temperature Range	Connector Type*
7, 8	DLC-525	n/a	0.040"-0.500" (1mm - 12.7mm)	0.030"-0.375" (0.762mm-9.5mm)	0.020"-0.200" (0.5mm - 5.08mm)	5.0 MHz	0.375" 9.52mm	32-122F 0-50C	Right Angle Microdot



*Right Angle Microdot - requires additional cable

Specifications

GENERAL

Size: Length 7.25" x Width 4.00" x Height 2.00" (184mm x 101.6mm x 50.8mm)

Weight: 1.15 lbs (.52 kg) with internal Li-Ion battery, 1.0 lb. (.45 kg) with optional Alkaline tray including 3 AA batteries

Temperature (gage operating): -4 to 122F (-20 to 50C)

Package: Designed for IP67 rating, custom, splash-proof, high impact plastic with illuminating rubber keypad for go/no-go testing

Transducer Connector Type: Lemo 00 (2 qty)

Bandwidth: 0.5-30 Mhz (-3dB)

Measurement Rate: 4 Hz or 25 Hz.

Pulser: 150V, Square Wave

Range: Thickness range depends on gage type, probe selection and material conditions. Typical range in corrosion mode, .020 - 23" (.076 - 584 mm). Typical range in precision mode, .006-23" (.152 -584 mm) in steel, as low as .003" (.076 mm) in plastic

Calibration: Cal zero, Cal velocity, Two-point calibration or Auto Calibration performs a two-point calibration using a 5-step test block

Material Velocity Range: .0200 in/usec-.7362 in/ μ S (0.508-18.699 mm/ μ S)

Languages: English, French, German, Spanish, Italian, Russian, Czech, Finnish, Chinese, Japanese, Hungarian

Batteries: Standard 3.7 V Li Ion internally rechargeable battery (11-27 hours; Standard mode of 4Hz and 74% brightness: 27 hour continuous operation, Fast mode at 25Hz, continuous measurements in echo to echo mode: 11 hours) or optional alkaline tray for 3 AA batteries

Shut off: selectable auto shut off 1-31 min. or never shut off

Transport case: Hard Plastic with high density molded foam cut out for gage and most accessories

Certifications: CE certified, RHOS compliant, designed for IP67

Standard Inclusions: ECHO series ultrasonic thickness gage, a transducer (ECHO 9 - DKS-537, ECHO 7,8 - choice of transducer up to 10mhz), transducer cable, 2oz bottle of couplant, operation manual, Data XL interface program, USB cable, Charger Adapter, Transport Case *A transducer is included with each model. Contact Danatronics for details based on exact inclusion per model

Warranty: Limited 2 year warranty under normal use on parts and labor for gage. Optional Dan-A-Care to add up to 3 more years

DISPLAY

Display: 3.5" high resolution color TFT display, 320 x 240 pixels (1/4 VGA), sunlight readable, including multiple color pallets

Backlight: Light Emitting Diode (LED) backlight. Includes variable light intensity.

DATALOGGER

Memory: Internal memory for stored setups standard on all models. For Datalogger models 2GB micro SD card standard and expandable up to 32GB

Stored Application Setups: Storage and recall of 2,700 calibration and set up files

Data XL: Interface program to send and receive stored readings, latest firmware and application set up files as two way communication from ECHO to computer (excel). Saved readings are .csv files and directly interfaces with Microsoft Excel.

USB: USB 2.0

MEASUREMENTS

Gain: Low, Standard, High, and Automatic Gain Control (AGC). 20-94 db in 1 db increments for gages with waveform.

Zoom: Automatically centers echos in the center of the display independent of material thickness

Units: English, Metric, Microseconds

Fast Min/Max: Displays minimum and maximum simultaneously with actual thickness at 25 Hz.

Alarms: Gage beeps and display changes color based on alarm condition

Vibrate: Gage can be set to vibrate on alarm (ideal for loud environments)

Transducers: Single, dual, delay lines, contact, immersion (depends on gage type)

ECHO 9 Measurement Types: ECHO 9 corrosion gage: Main bang to first backwall echo, echo to echo and velocity mode (displays acoustic sound speed based on entered thickness)

ECHO 7 & 8 Measurement Types: A precision gage: Class 1, Main bang to first back wall echo, Class 2, Interface echo to first backwall and Class 3, echo to echo after interface echo... Class 2 and 3 use high frequency single element delay lines or immersion probes, velocity mode (displays acoustic sound speed based on entered thickness)

Freeze Mode: Direct access to freeze display (ideal for high temperature applications)

Hold Mode: Holds display to retain last thickness reading

Differential Mode: Displays the difference from actual thickness measurement in absolute or percentage of a user entered reference value

Resolution: .001" or .010" (.01mm or .1mm) as corrosion gage and .0001" or .001" (.001mm or .01mm) as a precision gage

ACCESSORIES

ECHO-MBH: Magnetic ball head/pipe stand for ECHO series (attaches to 1/4x20 standard connection point on the back of the unit)

ECHO RB: Rubber boot available with padded wrist strap, 4 point chest harness, chest harness, built in bail (stand) with locking position and finger strap for easy one hand operation. ECHO RB is included with ECHO 7,8 or 9 as DLW models

ECHO-ABP: Alkaline Battery Pack (3- AA) for ECHO series. Battery life 3 Hours

ECHO-RPP: Remote Power Pack plugs into USB port to provide power/recharge to ECHO series

HARDWARE/SOFTWARE

Hardware Options: EZ Scan B-Scan encoder, Bluetooth, foot switch

Field Upgradeable Software Options: Datalogger with B-scan, Live waveform, Precision mode, Corrosion mode, Oxide scale, Angle Beam

Data XL Pro Software: allows sending of A and B-scan images to computer for advanced reporting

Item	SpecificatiOn	ECHO 9 Corrosion Gage				ECHO 7 Precision Gage				ECHO 8 Corrosion and Precision Gage			
		ECHO 9	9W	9 DL	9 DLW	ECHO 7	7W	7 DL	7 DLW	ECHO 8	8W	8 DL	8 DLW
Scan Mode	4 or 25 Hz. displays actual and min or max at same time	✓	✓	✓	✓	✓	✓	✓	✓	✓	✓	✓	✓
Memory	2 Gb micro SD included, expandable to 32 Gb	○	○	✓	✓	○	○	✓	✓	○	○	✓	✓
Alarms	Display color changes and can vibrate on alarm	✓	✓	✓	✓	✓	✓	✓	✓	✓	✓	✓	✓
Illuminating Keypad	Translucent F keys, red, yellow, green for alarm, blue for charging	✓	✓	✓	✓	✓	✓	✓	✓	✓	✓	✓	✓
Velocity Mode	Displays material sound speed after entered known thickness	✓	✓	✓	✓	✓	✓	✓	✓	✓	✓	✓	✓
Echo To Echo	Ignores coatings	✓	✓	✓	✓	*	*	*	*	✓	✓	✓	✓
Range	Can adjust range from zoom, 0.5, 1, 2.5, 10, 23"	○	✓	○	✓	○	✓	○	✓	○	✓	○	✓
Rectification	Half +, half -, full rf	○	○	○	✓	○	○	○	✓	○	○	○	✓
Live Waveform (A-Scan)	Displays live waveform	○	✓	○	✓	○	✓	○	✓	○	✓	○	✓
Datalogger	Alpha numeric 20 character ID, 32 character file, linear, 2d, 3d and boiler	○	○	✓	✓	○	○	✓	✓	○	○	✓	✓
B-Scan	Displays time based cross section of material under test	○	○	✓	✓	○	○	✓	✓	○	○	✓	✓
B-Scan Encoder	Displays encoded cross section of material under test	○	○	○	○	*	*	*	*	○	○	○	○
Dual Probe Use	Wide variety of dual transducers from 1 to 10 Mhz.	✓	✓	✓	✓	*	*	*	*	✓	✓	✓	✓
Single Element Probe	Wide variety of single element transducers from 1 to 20 Mhz	LTD	LTD	LTD	LTD	✓	✓	✓	✓	✓	✓	✓	✓
Stored Setups	Store up to 2,700 custom applications with file naming	✓	✓	✓	✓	✓	✓	✓	✓	✓	✓	✓	✓
Coating Thickness	Displays substrate and coating thickness simultaneously	○	✓	○	✓	○	✓	○	✓	○	✓	○	✓
Temperature Correction	Corrects for sound speed difference at elevated temperatures	○	✓	✓	✓	○	✓	✓	✓	○	✓	✓	✓
Alkaline Battery Tray	Ability to swap in 3 AA batteries	○	○	○	○	○	○	○	○	○	○	○	○
Rubber Boot	Custom rubber boot with built-in bail and 4 point chest harness	○	○	○	✓	○	○	○	✓	○	○	○	✓

*available with software upgrade to ECHO 8

○ = Software Options that are field upgradeable. Encoded B-Scan requires additional hardware modifications.

LTD = Limited, see transducer chart



6805 COOLRIDGE DR ■ TEMPLE HILLS MD 20748
 301-449-7300 ■ 800-638-0554 ■ FAX 301-449-7011
 EMAIL: sales@detek.com

CL5

Ultrasonic Precision Thickness Gauge



Micrometer Precision in a Rugged Package

The CL5 is an easy-to-use precision thickness measuring solution for components used in the automotive and aerospace industries, such as:

- Cast and stamped metal components made of aluminum, steel, copper, bronze
- Machined workpieces
- Chemically milled components
- Metal strips, metal plates
- Plastics and composites
- Glass

The instrument can be held in one hand or placed on flat workpieces, making the CL5 a compact way to test your material for the required thickness or checking for sheet corrosion.



Compact Solution With a Full Range of Functionality

The CL5 precision thickness gauge offers a full range of functionality in an easy to use, compact and rugged package. Three soft keys directly under the display activate the functions shown on the display menus. Four directional keys help make menu changes and navigation of the text entry screen simple and efficient.

The graphical display presents the user with seven different operation modes. The user can select Normal, Minimum Scan, Maximum Scan, Differential/Rate of Reduction, Thk+A-Scan (option), Velocity (option) or Quality View. The CL5 uses a programmable data recorder for easy set up of data files from the PC. The SD Card memory system places all the data recording and set-up information on a removable SD memory card. The files are formatted allowing drag and drop files when plugged directly into the PC. Other data such as digital photographs can also be stored on the same SD card. The CL5 allows direct connection to the PC, using a serial or USB port (with optional cable).

Simple Operation

The CL5 is a very straightforward instrument to operate. The MODE key progresses the user through a series of selection and set-up menus and back to the measurement mode. One press of the MODE key displays a table of standard probes and up to five special set-ups. Another press of the MODE key displays a set-up menu where the user can easily scroll through the menu, see the current settings and make fast changes to any of the displayed settings.

A supervisor lock-out function enables a knowledgeable user to set up all the specific measuring functions and settings of the CL5 and lock the settings so critical settings cannot be changed by a subordinate user.

Additional advantages offered by this compact, multifunctional instrument include:

- Enhanced measurement performance produces stable and repeatable thickness values
- Seven measurement and display modes: Normal, Minimum Capture, Maximum Capture, Differential and Rate of Reduction, Velocity (with CL5 VL option), Thickness+A-Scan (with Live A-Scan Option) and Quality View Mode (with Data Recorder option).
- Snapshot A-Scan on all models
- Hollow/Fill thickness digits showing coupling or non-coupling status
- Visual LED alarm to alert user when measurements are exceeding the user selectable limit values
- Customer parameter set-ups for special configurations and quick instrument set-up
- Flexible power system via standard AA batteries or rechargeable battery pack system (standard)
- Multi-language user interface
- Automatic ultrasonic performance (gain and gate controls)
- Wide variety of standard probes (sold separately)

CL5—Simply reliable, reliably simple

The Velocity Option: Performance and Flexibility

The CL5 Velocity option gives the user an added measurement mode used for determining the velocity of a known thickness of material. Material thickness can be entered manually via the CL5 keyboard or a digital caliper can be connected, allowing the thickness value to be sent electronically from the caliper to the CL5. The user simply places the probe on the part, and the CL5 displays the material velocity of the test object. Both the thickness and the velocity value can be stored in the Data Recorder and downloaded to the PC.

The Live A-Scan Option

The optional Live A-Scan feature gives the user a real time view of the echoes being digitally measured by the CL5.

Viewing the Live A-Scan can aid users when attempting to properly align the probe and the test object to achieve the best measurement values. Viewing the Live A-Scan enables the user to ensure the proper echoes are being measured and the digital value is correct.

The Data Recorder Option

The Data Recorder option permits the quick and easy storage of thickness values in file form. Fully user-programmable, it stores up to 10,000 measured values or as many as 500 values with attached A-Scan.

The programmable data recorder allows creation of data recorder files directly from the CL5 keypad, or from the PC using the flexible UltraMATE® or UltraMATE® Lite software program. The Data Recorder supports the use of alphanumeric file names, standard linear and grid files and custom linear files.

Extended file types store the thickness values, velocity settings and other critical data for each measurement point, making the CL5 and UltraMATE® ideal for test data management.

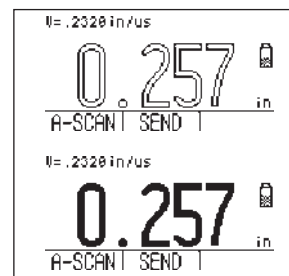

Filled digits indicate successful coupling

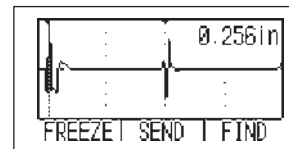

Live A-Scan for more precise evaluations

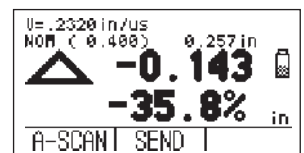

Rate of reduction

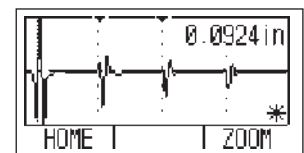

Snapshot A-Scan

PANEL 3579			
	A	B	C
1	0.0258	0.0248	0.0226
2	0.0217	0.0217	EMPTY
3	EMPTY	EMPTY	EMPTY

HOME | SEND |

Data recorder

Achieve More Precision With Quality View

Quality View Mode permits Data Recorder-driven control and capture of thickness measurements. It is ideal for singular parts or structures with numerous measurement points that have different target thicknesses and/or varying upper and lower limits or tolerances.

Uses of Quality View Mode include:

1. Fast collection of thickness measurement data for statistical analysis during variation control and quality assurance.
2. Digitally capturing thickness measurement data for quality records and traceability.
3. Variation control of work in progress on the manufacturing or workshop floor.

Quality View Mode displays the current measurement location name, a bar graphic of the thickness measurement that shows the lower specified limit value, the nominal/target value, the upper specified limit and a numerical readout of the measurement.



Selection of Quality View Mode displays

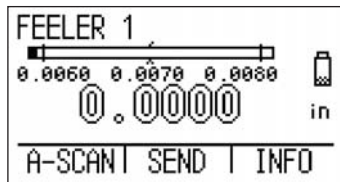

Numerical value of thickness is filled when probe is coupled to the location of measurement

To work in Quality View Mode, custom four-point linear files are created in either Microsoft® Excel or UltraMate® software applications on a PC and downloaded to the CL5 using the optional serial or USB cable. Measurements can also be uploaded into a PC for processing and analysis using Microsoft® Excel, UltraMate® or a third party statistics and/or quality software application.

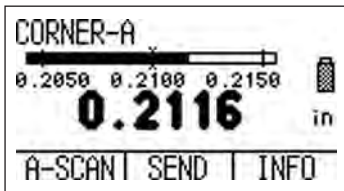

Quality View Mode

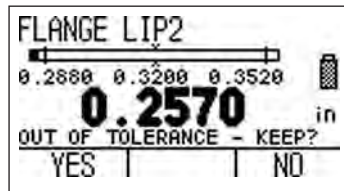

Out of tolerance dialogue

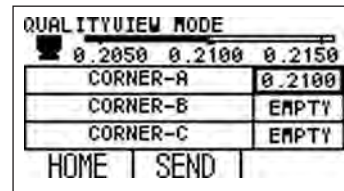

Measurement Review Mode

Technical Data

Measuring Range	.005 in to 20.00 in (0.13 mm to 500 mm); depends on material, probe, surface condition and temperature
Units and Measuring Resolution	Inch – 0.0001, 0.001, 0.01 Millimeter – 0.001, 0.01, 0.1
Material Velocity Range	0.03937 to 0.78736 in/ μ s 1000 to 19999 m/s
Receiver	Bandwidth of 1.0 to 16 MHz at –6 dB
Update Rate	User selectable 4 or 8 Hz, up to 32 Hz in Min Cap or Max Cap mode
Display Type	Graphical LCD 64 x 128 pixels 2.25 in x 2.56 in (40 mm x 57 mm) with backlight and adjustable contrast
Thickness Display	Five-digit display with 0.75 in (19.5 mm) height digits in standard mode and 0.25 in (6.35 mm) height digits in Thickness + A-Scan mode, solid or hollow digits coupling indicator, A-Scan view – R.F. mode only
Display Modes	Thickness (includes Snapshot A-Scan), Thickness + Live A-Scan (optional), Minimum Capture, Maximum Capture, Differential and Rate of Reduction, Velocity Mode (optional), Quality View Mode (optional)
Supervisor Lockout	Alphanumeric password lockout for calibrations, set-up and Data Recorder
I/O Port	Bi-directional serial RS-232: baud rate 1200, 9600, 57600 and 115200
Data Recorder	Programmable Data Recorder, 120 files max. on each 64 MB SD card
File Formats	Grid created from instrument keypad. Grid and Custom Linear files accepted from UltraMATE [®] software.
Power Supply	Three AA batteries (Alkaline, NiMH or NiCad) or custom rechargeable battery pack

Environmental Sealing	Impact resistant, dust and splash proof, gasket-sealed, case-tested to IP54
Weight	0.92 lb (420 g) with batteries
Size	7.1 in H x 3.7 in W x 1.8 in D (180 mm x 94 mm x 46 mm)
Temperature Range	Operating: –10 °C to +60 °C Storage: –20 °C to +70 °C
Operating Languages	English, German, French, Spanish, Italian, Russian, Japanese, Chinese
Application Software	UltraMATE [®] Lite and UltraMATE [®]
Base Instrument Package	CL5 precision thickness gauge Lithium poly battery pack AC power supply Plastic carry case Wire stand XL couplant sample, 4 oz Firmware upgrade CD-ROM Operating manual Operating instruction card Certificate of Conformity
Options	CL5 AS OPT – Live A-Scan option CL5 DR OPT – Data Recorder option CL5 VL – Velocity option
Accessories	PCCBL-690 USB PC cable PCCBL-419 serial PC cable Li-135 lithium poly battery pack AC-296 AC power supply UltraMATE [®] Lite or UltraMATE [®] Data Management software

CL5 Compatible Transducer Specifications

Model	Probe Type	Nominal Frequency	Contact Diameter	Measuring Range (in Mild Steel Unless Noted)
Alpha 2 DFR/CLF4	Standard Delay Line	15 MHz	0.30 in (7.6 mm)	0.007 to 1.0 in (0.18 to 25.4 mm)
Alpha 2 F/CLF5	Fingertip Contact	10 MHz	0.38 in (9.5 mm)	0.060 to 10.0 in (1.52 to 254 mm)
Mini DFR	Thin Range Delay Line	20 MHz	0.19 in (4.8 mm)	0.006 to 0.2 in (0.16 to 5.1 mm)
Alpha DFR-P	Delay Line for Plastic Materials	22 MHz	0.30 in (7.6 mm)	0.005 to 0.15 in (0.13 to 3.8 mm) in plastic materials
K-Pen	Delay Line Pencil Probe	20 MHz	0.065 or 0.090 in (1.7 or 2.3 mm)	0.008 to 0.175 in (0.20 to 4.4 mm)
CA211A	Standard Contact	5 MHz	0.75 in (19.1 mm)	0.060 to 20.0 in (1.52 to 508 mm)



GE Inspection Technologies: productivity through inspection solutions

GE Inspection Technologies provides technology-driven inspection solutions that deliver productivity, quality and safety. We design, manufacture and service ultrasonic, remote visual, radiographic and eddy current equipment and systems. We offer specialized solutions that will help you improve productivity in your applications in the aerospace, power generation, oil & gas, automotive or metals Industries.

www.ge.com/inspectiontechnologies

Krautkramer UltraMATE / UltraMATE lite

Documentation programs for the wall thickness measurement

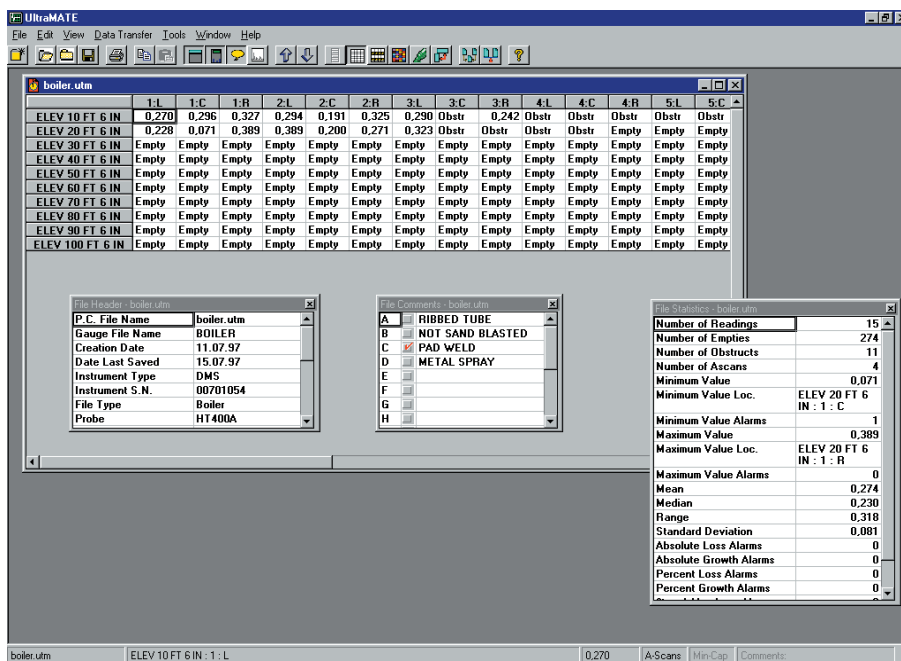

Features of UltraMATE

Generation of color reports including various possibilities for analyses:

- for example, color histograms: measured values are divided into ranges which have certain colors assigned to them for the range evaluation. The number of readings in each one of the defined value ranges is indicated - either as an absolute number or as percentage of total.
- color assignments also clearly show the distribution of minimum/maximum limit values exceeded or not reached for individual or several measurement series over a certain time period
- comparison of several measurement data sets on the screen
- merging of up to five different measurement data sets into one single file
- data compatibility with UltraPIPE and older DMS MATE files
- Viewing of attached A-Scan, B-Scan and Microgrids (when supported by the instrument)

UltraMATE is an easy-to-use program for the management of thickness measurement data. It ensures transfer, storage, analysis and documentation of the data, and it makes extensive user-friendly functions available - for example for professional test report layouts.

UltraMATE lite is the simplified program version enabling to transfer data from the gauge to the PC, store them there, and to print them out in different fixed-format reports.

Features of UltraMATE lite

- automatic communication setup
- data exchange via Windows Clipboard for an easy transfer of measurement data to spreadsheet and word processing applications
- File creation wizard supporting 6 different file types (8 file types in UltraMATE)
- Parameter Set transfer to and from DMS, DMS 2, CL 400 and CL 5 instruments

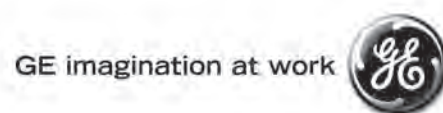

USM Go+

Small but tall.
All you expect from
an ultrasonic flaw
detector, packed in
a handheld.

Introducing the new USM Go+ that takes field inspection NDT to the next level. Light, handy and controlled by an intuitive arrow-keypad, it has the latest industrial electronics under the hood and offers a host of Surface Resolution which allows for reliable detection of defects located just below the surface of the test piece.



USM Go+ When design and technology shake hands

Built for practice

The USM Go+ ultrasonic flaw detector offers you the best of both worlds: the performance and features of a tabletop ultrasound detector in a small, ultra-portable handheld instrument that is outstandingly equipped for ultrasound detection in the field. Its ergonomic design, useful features and big performance are the result of carefully listening to the experience of the people in the field who, through their everyday practice, know best what it takes to do a good job.



What a field NDT operator needs is:

→ *An instrument you can use with one hand*

The USM Go+ is the ideal device for ambulant ultrasonic testing. It is light (about 800 g) and so small it fits in your hand. It's the perfect tool for operation in confined spaces, areas with difficult access or other difficult environments.

Actually, you operate it with one hand, thanks to the arrow-keypad, which allows for intuitive navigation and fast and precise adjustments. That comes in handy, when you need your other hand to adjust the probe or just hold on to a ladder. Are you left-handed? No problem, use the 'flip' function to adapt the instrument to your hand.

→ *A robust, heavy duty device*

Its molded rubber casing makes the USM Go+ the sturdy instrument you need in the sometimes harsh conditions 'in the field'. It is dust- and waterproof to IP67 and has been tested according to the military standards.

→ *The biggest and brightest screen in its class*

The 108mm x 64,8 mm screen with an outstanding resolution of 800 x 480 pixels offers you best-in-class readability. Moreover, it is exceptionally bright so you can still discern the image even in full sunlight. On the other hand, when working in the dark, you can reduce the brightness in order not to get blinded. An integrated stand allows you to optimize the viewing angle, when the instrument is desk or bench mounted.

→ *Outstanding UT performance*

Equipped with state-of-the-art technology, the USM Go+ takes UT performance in handheld instruments a step further. The high Near Surface Resolution enables you to detect flaws located just under the surface of the test piece, with a high degree of reliability. A wide Pulse Repetition Frequency range allows you to use the USM Go+ at low PRF to inspect forged parts without any "ghost" echoes and to inspect welds at high PRF when fast and regular scanning movement is required.

→ *A tool that boosts your productivity*

Ultra-portable, easy-to-handle, intuitive operation, high performance - the USM Go+ is your plug & play tool that will give your productivity a boost the moment you start using it.



Other key features & benefits

- Very long life battery (> 6 hours).
- A standard USB connection allows for data to be downloaded from the flaw detector for further analysis or storage.
- The instrument's 2 GB memory can be easily exchanged by SD cards up to 16 GB.
- Reports are produced in jpeg format so there is no need for special reading software.
- Backwall Echo Attenuator (BEA) helps to find very small defects, improving detectability.
- Automatic Gate Threshold for the 2 gates ensuring accurate measurements made under the same conditions.
- A-Scan video recording up to 8 minutes allows live reporting.

A wide range of applications

The USM Go+ has been designed to provide flaw detection capability in inspection situations throughout the industrial and process spectrum, from aerospace to power generation and from the automotive sector to the oil and gas industry.

Weld Inspection:

- Trigonometric projections
- AWS
- DAC
- DGS

Inspection of Forgings and Castings:

- Manual PRF adjustment
- Phantom echo indicator
- DGS
- Backwall Echo Attenuator (BEA)

Inspection of rails:

- High PRF (up to 2000 Hz)
- Lightweight: 850 g (1.87 lb.)
- Small size and ergonomics

Inspection of Composites:

- RF Display
- 2 gates with B-start triggered with echo in gate A
- TCG correction with high slope 120 dB/ μ s
- Reflector depth indicated in layer

For more demanding applications:

- Narrow band filters
- Low noise digital amplifier
- Square wave pulser



Technical Specifications of USM Go+

Display	5 inch, 800 x 400 pixels, 108 x 65 mm (W x H), >200 cd/m ²
Size (W x H x D)	175 x 111 x 50 mm
Weight	850 g with battery
Protection class	IP 67
Operating temperature	0 – 55 °C
Battery	Li-Ion, rechargeable, 6 hours operation time
Power adapter / charger	100 – 240 V AC, 50/60 Hz
Probe connector	2 x Lemo-00 (T/R)
PC interface	Micro USB
Memory card	SD-Card 16 GB max
Reporting	Test report and A-Scan screen shot on SD-Card, Video recording of A-Scan
Pulser	120 – 300 V, 30 – 500 ns, flank < 10 ns, Spike, Square wave option
Puls Repetition Frequency	15 – 2000 Hz
Damping	50 and 1000 Ohm
Receiver	110 dB dynamic, 0,9 – 20 MHz analog bandwidth
Filter	BB 1 – 5 MHz, 2,25 MHz, 4 MHz, 5 MHz, 10 MHz, 13 MHz, 15 MHz
Gates	A and B independent, B triggered by A, C option
Units	mm, inch, µs
Options	AWS calibration tool (AWS D1.1), DAC 16 points according to EN 1712, EN 1713, EN 1714, ASTM E164, TCG 120dB dynamic, DGS cal. tool according to EN 1712, EN 1713, EN 1714, ASTM E164, Data Logger, 3rd gate C, Square Wave Pulser
Compliance	EN 55011, EN 61000-6-2: 2011, EN 12668, ASTM E 1324, E317, ANSI/NCSS Z 540-1-1994, MIL-STD 45662A, MIL-STD 2154



www.ge-mcs.com

GEIT-XXXXXEN (03/14)

GE
Measurement & Control

More than You've Ever Seen.



Inspection Technologies:
Krautkramer USM 36

The new universal portable ultrasonic flaw detector from GE, combining ergonomic and robust design and the biggest display screen of its class with state-of-the-art UT performance.



GE imagination at work



Krautkramer USM 36: a proven reliable and robust ultrasonic flaw detector performer

The Krautkramer USM 36 is the latest development in GE's USM range of flaw detectors. It combines the 21st century operating platform with the reliable and robust hardware of GE's well-established Krautkramer portable flaw detection instruments. It incorporates a range of innovative features to ensure that this new instrument is adopted as the everyday workhorse of flaw detectors by NDT inspectors globally.



Largest Viewable A-Scan Display in its Class

1

- An important improvement in the Krautkramer USM 36 is its large 7 inch screen, with an 800x480 pixel resolution. The entire area is available to display crispy A-scans, making it the best in its class. Signals can be easily viewed and accurately interpreted, even in bright sunlight, with tired eyes at the end of a long working day.



2

Simple and Efficient Operation

- The Krautkramer USM 36 uses the familiar rotary knobs of previous models but the function keys have now been minimized into a simple, intuitive 6-key keyboard, allowing simple and efficient operation;
- Inspection set-up is also easy. Not only for technicians who have used USM Go or USM Go+ for previous inspections, as set-up data is transferable directly from these instruments, which share the same user interface. This commonality of interface also ensures a rapid learning curve for technicians familiar with the USM Go instruments.



3

Flexible Data Reporting and Storage

- As well as easy-to-interpret the crispy A-scans, data reporting on the Krautkramer USM 36 can also include screen shots and A-scan videos, where A-scans can be recorded for subsequent analysis or to provide proof of inspection. All data is stored on a removable SD-card and reports can be in jpeg or BMP format.



6

Available in Three Versions

- The versatile instrument is offered in three versions to meet the most standard inspection codes. The most advanced version can operate in DAC, AWS and DGS modes, features a powerful square wave pulser for excellent material penetration and can accommodate GE's patented *trueDGS* probe technology, which offers unrivalled accuracy in sizing of flaws using the DGS method, as well the patented Phantom Echo Detection technology.

5

Can be Used in the Harshest of Environments

- The Krautkramer USM 36 is fully protected against dust and water ingress to IP66 and can be operated in ambient temperatures from -10°C to +55°C. It can be used in sandy deserts, frozen wastes and in the humid tropics.
- The new flaw detector weighs just 2.2 kg and is battery- or mains-operated. Its Li-ion battery has an operating life of more than 13 hours, with an integrated battery charger for those longer shifts.

4

Comprehensive Connectivity

- Connectivity is a major feature of the Krautkramer USM 36. Data can be stored on removable SD-card or USB memory stick, either for record purposes or to allow data sharing. A VGA connection allows the instrument's display to be shown on an external monitor or on a projector screen for training purposes.

Applications

The Krautkramer USM 36 has been developed for day-to-day use throughout the industrial spectrum, from weld inspection and corrosion measurement in the power generation and petrochemical industries, to castings and forgings inspection and thickness measurement in the automotive, metals and aerospace sectors to the inspection of special materials.

Weld Inspection in the Power Generation and Petrochemical Industries

Intuitive tools facilitate analysis and the use of color on the ultra-bright, 7 inch screen allows significant display benefits during weld inspection:

- Monitor gates and curves are displayed in various colors;
- Messages and alarms are displayed in red;
- A-scans can be displayed in different colors to assist comparison;
- Color display of all parameters involved in flaw location, including sound path, surface distance, depth position and leg number;
- GE's patented color coded display of legs for angle beam inspection.



Precise Thickness Measurement in the Automobile Industry

The Krautkramer USM 36 provides precise thickness measurement, as the sound path differences are measured very accurately at the peaks of an echo sequence.

Corrosion Measurement in the Power Generation and Petrochemical Industries

Corrosion measurement can be carried out using dual element probes, where the screen displays both the thickness measurement and the A-scan, ensuring maximum reliability. A minimum capture mode provides the thinnest measured reading at the end of a continuous scan. An auto-freeze function, which minimizes the probe's surface contact time, is used for measuring structures and components with hot surfaces.

Inspection of Forgings

The instrument's Phantom Echo Detection technology is used in the inspection of fine grained and long work pieces to ensure accurate detection of flaws but not Ghost Echoes.

Inspection of Special Materials

The powerful square wave pulser which is an available option for the Krautkramer USM 36 provides excellent penetration of difficult materials, such as those sometimes used in the aerospace and automobile industries.



Technical Specifications of Krautkramer USM 36

Display screen

Size Diagonal	7"
Active range (W x H)	152.4 x 91.44 mm ²
Resolution (W x H)	800 x 480 pixels
Range	4 ... 14,108 mm (555") for longitudinal wave

Display

Display shift (delay)	-15 ... 3,500 µs
Probe delay	0 ... 1,000 µs
Velocity	250 ... 16,000 m/s
PRF	Automatically optimized 15 ... 2,000 Hz, 3 automatic setting modes: Auto Low, Auto Med, Auto High, Manual

Connectors

Probe connectors	2 x LEMO-1 or 2 x BNC
USB interface	USB type B connector
Service interface	LEMO-1B, 8 pin

Pulser

Pulser mode	Spike pulser, optionally: Square-wave pulser
Pulser voltage (SQ mode)	120 ... 300 V, in steps of 10 V with a tolerance of 10%
Pulser falling/rising time	max. 10 ns
Pulser width (SQ mode)	30 ... 500 ns, in steps of 10 ns
Pulser amplitude (Spike mode)	low: 120 V, high: 300 V
Pulser energy (Spike mode)	low: 30 nS, high: 100 nS
Damping	50 ohms, 1000 ohms

Receiver

Digital gain	Dynamic range 110 dB, adjustable in steps of 0.2 dB
Analog bandwidth	0.5 ... 20 MHz
Equivalent input noise	<80 nV/√Hz
Filters	Broadband: 1-5 MHz / 2, 2.25 MHz / 4, 5 MHz / 10 MHz / 13, 15 MHz
Rectification	Positive half-wave, negative half-wave, full wave, RF signal

Gates

Independent gates	Gates A and B (triggering by gate A), Gate C (option, triggering by gate A or B)
Measurement mode	Peak, Flank, J-FLANK, FIRST PEAK

Memory

Card slot	SD-card slot for all standard SD-cards
Capacity	8 GB, SD-card
Datasets	UGO data structure in ASCII
Reports	JPG or BMP format

General

Battery	Li-Ion, operating time: 13 hours with full charge Charging method (standard): internal with power adapter Charging method (optional): external charger Charge level: proportional charge level indicator
Power adapter	Universal power supply unit 100 ... 240 VAC, 50/60 Hz
Size (W x H x D)	255 x 177 x 100 mm (10" x 7.0" x 3.9")
Weight	2.2 kg incl. battery
Languages	Bulgarian, Chinese, Czech, Dutch, English, Finnish, French, German, Hungarian, Italian, Japanese, Norwegian, Polish, Portuguese, Romanian, Russian, Spanish, Swedish
Damp heat and humidity (storage)	EN 60068 Part 2-30 6 cycles: 9 hrs at +25°C up in 3 hrs to +55°C, 9 hrs at +55°C then down to +25°C in 3 hrs, at 93% humidity
Vibration	EN 60068 Part 2-6 2g per axis, 5 ... 150 Hz, 1 oct/min, 25 cycles
Shocks	EN 60068 Part 2-27 1000 cycles per axis, 15 g, 11 ms, half-sine
Enclosure	IP66 according to IEC 60529
Operating temperature	-10 ... 55°C
Cold operation	-10°C for 16 hrs, 502.5 Procedure II
Heat operation	+55°C for 16 hrs, 501.5 Procedure II
Storage temperature	-20 ... +60°C, without battery
Cold storage	-20°C for 72 hrs, 502.5 Procedure I
Heat storage	+70°C for 48 hrs, 501.5 Procedure I

Options

AWS	AWS calibration tool, according to AWS D1.1 Structural Welding Code
DAC/JISDAC/CNDAC	DAC calibration tool, 16 points, according to EN 1712, EN 1713, EN 1714, ASTM E164, ASME, ASME III, JIS Z3060, GB11345 TCG: 120 dB dynamic, 110 dB/µs slope
DGS	DGS calibration tool, according to: EN 1712, EN 1713, EN 1714, ASTM E164
Data logger	Grid file creation
3G	Gate C
SWP	For pulser parameter optimization, voltage setting 120 ... 300 V in steps of 10 V, pulse width setting 30 ... 500 ns in steps of 10 ns
Phantom-PRF	Phantom-PRF for the identification of erroneous echoes caused by multiple reflections in low-attenuation materials
BEA	Blackwall Echo Attenuation

Specifications according to EN 12668

You will find the specifications according to EN 12668 for your instrument on the product CD included in the standard package.



www.ge-mcs.com

GEIT-20067EN (10/13)

Krautkramer USN 60/60L

Portable Ultrasonic Flaw Detectors



GE Inspection Technologies has optimized its USN 60 series for use in direct sunlight and operation at extreme temperatures. These new characteristics make the instruments ideally suited for outdoor use with its increased long battery operation time.

Depending on the applications challenges, you have the choice between the USN 60 and the USN 60L version.



The USN 60 series: outstanding ultrasonic performance

The combination of the rugged USN durability, 11 hours of battery operation, fast rotary knob operation, outstanding ultrasonic performance, and the “square wave pulser” form a powerful portable ultrasonic inspection tool.

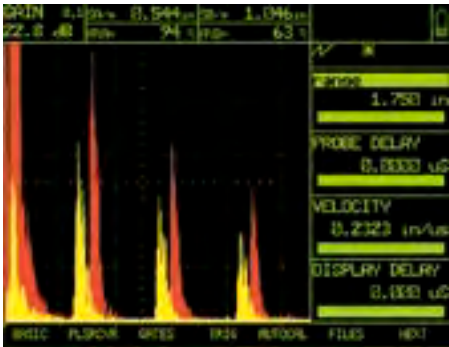

Optimized outdoor use design

The USN 60 / USN60L flaw detectors are especially designed to be used outdoors:

- Extreme temperature use (-20°C to +55°C / -4°F to 130°F)
- Easy to view in direct sunlight
- 11 hours battery operation

Vibrant colors

- Hi-resolution color LCD display produces “Analog Look and Performance” echo dynamics.
- 4 selectable vibrant display color schemes to match lighting conditions.
- Gates and gate functions are color coded for easy identification and fast adjustment.

User preferred features

- Simple operation with fast rotary knob adjustments; gain is always directly accessible with the left-hand rotary knob and lockable.
- Auto CAL makes calibration fast & easy.
- 15 Hz to 6 kHz (spike mode) PRF and 15 Hz to 2 kHz (square mode) PRF (pulse repetition frequency).
- 2 independent gates monitor amplitude and soundpath distance for both flaw detection and thickness measurement applications.
- 250 KHz to 25 MHz frequency range.
- RF display mode enhances signal evaluation and bond inspection of dissimilar materials.
- 4 selectable damping settings (50, 75, 150, 500 ohms) for optimum probe performance.
- 1 mm to 28 m (0.040” to 1100”) range (in steel) covers thin to lengthy acoustically clean materials.
- dB REF key evaluates subsequent echoes gain value and amplitude against the highest echo in Gate A (reference echo) when activated.
- IF (Interface) Gate Option for automatic start of the display, Gate A, Gate B, and / or DAC / TCG for immersion testing applications.
- VGA Output Option provides an easy way to connect to a PC monitor or PC projector for viewing by large audiences or training purposes.
- RF Output Option outputs the raw RF waveform via a standard Lemo connector for further analysis.
- BEA (Backwall Echo Attenuator) Option allows independent gain control of the region under Gate B for backwall echo monitoring.
- 19” Rack Mount Model.

Wide range of applications

A 6 kHz pulse repetition frequency, real-time analog and TTL outputs makes the USN 60 flaw detectors series ideal for a wide range of automated systems testing applications. The exclusive SmartView feature displays even the shortest echoes for critical scanning and rotating part inspections.

The quality, durability, dependability and ease of use that you have come to expect of Krautkramer’s popular USN Series of instruments remains. From rugged field inspections to

high resolution thin measurements, long acoustically clean materials, and immersion systems, the USN 60 flaw detector family extends the range of applications that a portable instrument can perform. Furthermore the selectable 450V Square Wave Pulser satisfies a wide range of tough-to-penetrate applications, such as difficult to penetrate metallic applications and especially non-metals inspection like composite materials.

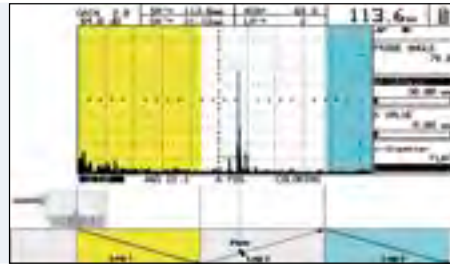

"Color Leg" indicator displays the legs of the angle beam inspection in different colors

Tools for easy weld inspection

- Color Leg allows easy identification of leg and skip distances for weld inspection.
 - GRID mode dynamically changes bands of display background colors for each leg.
 - A-SCAN mode dynamically changes the color for each leg of the "live" A-Scan
- Weld Rating Calculation simplifies the rating of weld indications according to AWS Specification D1.1. (Formula $D = A - B - C$).
- Trigonometric flaw location function with curvature correction automatically calculates depth, surface distance, and sound path to flaw along with the leg of the inspection when using angle beam probes. All TOF measurements can be displayed in mm, inches or μs .
- SmartView function along with variable persistence freeze modes displays the most important information (relevant shot) for a test.
- Real time (single shot) analog and TTL outputs handle a wide range of automated systems applications.
- Choose from Four Freeze Modes: ALL, Peak Std, Compare or Envelope for optimum waveform evaluation and comparison.
- Three Variable Persistence Modes are selectable in Freeze Envelope to visually assist flaw detection & evaluation for scanning and moving part inspections.
- Compare frozen reference wave-forms to live A-Scans in different colors to easily interpret test results.

Tools for easy defect sizing

- 40 dB dynamic DAC/TCG Option corrects for distance/amplitude variations from material loss and beam spread with ability to edit or insert recorded echoes individually. Up to four DAC curves can be drawn on the screen at one time to show +/- dB curves in addition to the originally recorded DAC curve.

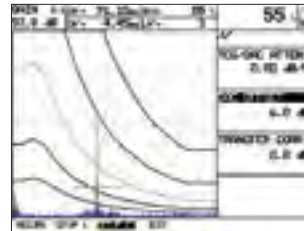

Tools for easy defect sizing
Multiple curve DAC shows recorded DAC curve in magenta with 4 additional curves based upon dB Offset feature for added flaw sizing assistance. TCG Attenuation and Transfer Correction features make it very versatile for use on other materials and surface conditions.

- DGS (Distance Gain Size) Option displays a curve for a particular equivalent reflector size. The ERS (Equivalent reflector size) function automatically calculates the corresponding equivalent reflector diameter in mm or inches for any echo in the measurement gate.

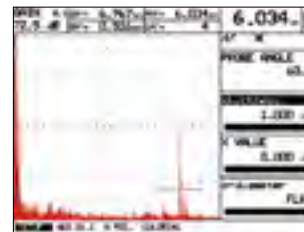

Four digital reading boxes at top display trigonometric calculations for weld inspection. (SA soundpath to flaw in gate A, PA projection distance to flaw in gate A, DA depth to flaw in Gate A & LA leg of inspection that flaw occurs in gate A)



Square wave pulser with tunable pulse width solves composite testing applications.

Options

DAC / TCG Option

Multiple Curve DAC (Distance Amplitude Curve)/ TCG (Time Corrected Gain) for echo amplitude adjustment and evaluation, 40 dB dynamic range, 12 dB/ μ s slope, record up to 16 points, recorded points are individually editable, new points can be inserted. Display four additional curves based upon dB offset feature from originally recorded DAC curve. TCG attenuation and transfer correction features enable use on other materials and surface conditions.

IF (Interface) Gate Option

For automatic start of the display, Gate A, Gate B, and / or DAC / TCG for immersion testing applications.

DGS Option

Displays a curve for a particular equivalent reflector size as a function of the distance from the probe to the reflector for 25 narrowbanded probes. The ERS (Equivalent reflector size) function automatically calculates the corresponding equivalent reflector diameter in mm or inches for any echo in the measurement gate.

BEA Backwall Echo Attenuator Option

Allows independent gain control of the region under Gate B for backwall echo monitoring.

VGA Output Option*

Provides an easy way to connect to a PC monitor or PC projector for viewing by large audiences or training purposes.

RF Output Option*

Outputs the raw RF waveform via a standard Lemo #00 connector for further analysis.

HiSPD High Speed Digital Output Option

Outputs amplitude or thickness values 20 times faster than RS 232 port.

* Order with new instrument only. Later upgrade not possible.

Documentation and recording

- Store & preview a minimum of 200 user-named data sets with A-Scans for quick recall and instrument setup.
- UltraDOC 4 software program for bi-directional communication with a PC for easy storage of data sets with A-scan and documentation of test results.
- UltraMATE™ software program simplifies the transfer, storage, analysis, and documentation of thickness data.
- Reports with A-Scans are output directly to a variety of printers.
- Alphanumeric Thickness Datalogger for flexible, convenient storage of thickness readings in Linear, Grid, or Custom-Linear file structures with user-input filenames, location I.D.'s, notes, memo, & header fields.

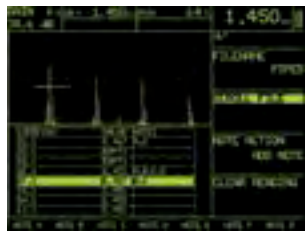

www.ge-mcs.com



Technical Specifications USN 60 / USN 60L

Range USN 60	0.040" to 1100" (1 mm to 28 m) at steel velocity; range selectable in fixed steps or continuously variable
Range USN 60L	range is 0.040" to 480" (1 mm to 12 m)
Material Velocity	Continuously adjustable from 0.0098 to 0.6299 inches/ μ s (250 to 16,000 m/s); 65 selectable material velocities
Display Delay	-20 to 3498 μ s in steel (dependent on range)
Probe Delay/Zero Offset	0 to 999.9 μ s
Damping	50, 75, 150, 500 ohms
Gain	0 to 110 dB adjustable in selectable steps 0.1, 0.5, 1.0, 2.0, 6.0, user definable, and locked
Test Modes	Pulse echo, dual, and thru-transmission
Pulser	Square wave excitation pulse
Pulse Voltage (Square wave pulser mode)	50 to 450 V scrollable in 10 V adjustments
Pulse Width (Square wave pulser mode)	Tunable from 50 to 1000 ns in 10 ns adjustments
Pulse Energy (Spike mode)	Low, High
Pulse Repetition Frequency USN 60	Autolow, autohigh, manually adjustable from 15 to 6000 Hz (spike mode) and 15 to 2000 Hz in square wave mode, in 5 Hz increments, external trigger (spike mode only)
Pulse Repetition Frequency USN 60L	Limited to 2000 Hz in both spike and square wave mode
Bandwidth (amplifier bandpass)	0.25 to 25 MHz with 10 selectable settings including broadband
Gate Monitors	Two independent flaw gates controllable over entire sweep range
Measurement Modes	Zero-to-first, multi-echo with selectable flank or peak detection
Rectification	Positive halfwave, negative halfwave, fullwave, RF
Reject (suppression)	0 to 80% linear
Units	Inch, millimeter, or microsecond selectable
Operating Temperature	-20° to 55°C (-4° to 130°F); -25° to 70°C (-13° to 158 ° F) storable
Languages	Selectable English, German, French, Spanish, Italian, Portuguese, Norwegian, Swedish, Finnish, Danish, Dutch, Russian, Czech, Romanian, Slovakian
Probe Connectors	BNC or Lemo selectable at order
Keypad	International symbols
Battery Power	Lithium Ion battery pack; NiMH, NiCad or alkaline cells substitutable
Battery Life	11 hours on Li-Ion battery pack
Size	11.1" W x 6.75" H x 6.25" D (282 x 171 x 159 mm)
Display	640 x 480 pixels Color LCD 132.48 x 99.36 mm
Weight	6.6 lbs. (3.0 kg) Li-Ion battery; 3.5 lbs.(1.6 kg) without battery
Color Leg	Easy identification of leg and skip distances for angle beam inspection in A-scan or grid background colors
Weld Rating Calculation	Simplifies the rating of weld indications according to AWS specification D1.1, (formula D=A-B-C)
Warranty	2 year conditional warranty on parts and labor; free 2nd year contingent upon return of unit within 13 months of purchase for recertification
Dust Proof/ Dripping Water Proof	As per IEC 529 specification for IP54 classification
Compliance	EMC/EMI: EN 55011:2007, EN 61000-6-2:2005 Ultrasound: EN 12668, ASTM E317

GEIT-20040EN (11/12)

Krautkramer USM 35X

Universal Ultrasonic Flaw Detector
with Bright Color Display and protected according to IP 66



A new design provides an improved environmental protection for everyday outdoor use.

Protection according to IP 66

A very sturdy housing has been designed for the USM 35X. We achieve a higher environmental protection and have improved the durability of this flaw detector for harsh use. The IP level corresponds to the degree of protection provided by the housing according to the IEC 529:1989.

IP 66 means that the instrument is totally protected, i.e. dust and water cannot penetrate into the instrument, even with heavy rain, sea spray and powerful jets of water coming from any direction.



Harsh field and industrial environments

- Extended temperature range from 0° C/32° F to 60° C/140° F (-10° C/14° F to 60° C/140° F after individual climatic testing)
- Weighs only 2.2 kg
- Extended battery life to 14 hours under real test conditions

Intuitive tools to help analysis

- The Color-Leg function displays coded information on the leg in color about angle beam inspection.
- 2 new carats (colorized triangles pointing at the echo for each gate).
- One carat ▽ pointing to the gate bar indicates the sound path measurement point at the echo
- The other carat ▲ pointing up indicates the amplitude measurement point at the echo in the gate.

Fast and bright color screen

Color brings you many additional benefits in your daily inspection job:

- Color display of monitor gates and curves (DAC, TCG, DGS) for direct recognition
- Messages and alarms in red characters for increased attention
- Use of color to display references (A-scan) to make comparisons easy



A-scan comparison

- Patented color coded display of legs for angle beam inspection of welds

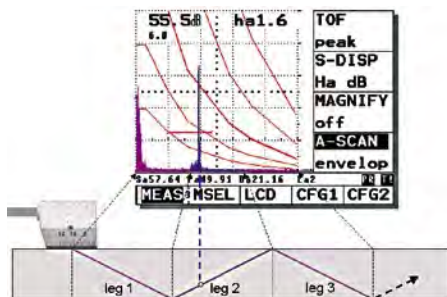

Color-coded display of legs in tests using angle-beam probes

- Colorized envelope curve display for echo dynamic analysis
- Multicolor screen combinations for operator preferences and to select best suitable color scheme according to the working environment.
- VGA output to connect the instrument to an external monitor or video projector

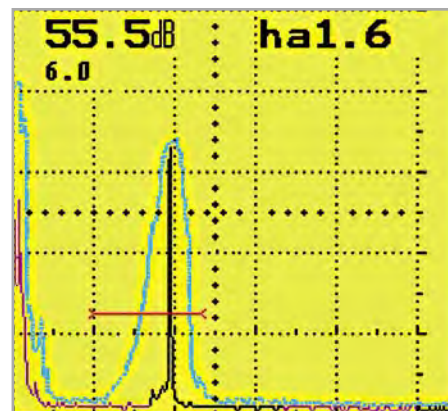

Envelope curve

New readings

Three new additional readings can be displayed for measurements taken with gates:

- dB-difference to reference gain with DAC / TCG (in the USM 35X DAC and USM 35X S)
- DGS reference gain (in the USM 35X S)
- Flaw classification according to JIS Z3060 (in the USM 35X DAC and USM 35X S)

Other benefits

We have also implemented innovations from the computer industry in the battery concept to make your daily work easier: the rechargeable lithium-ion battery pack enables you to carry out your inspections for at least 14 hours. Charging is easily carried out internally within the instrument over night just by connecting the power pack/battery charger to the USM 35X. You can also insert 6 normal C-cells should the battery pack be drained and if no A/C power connection is available.

The optimum combination of innovation and proven performance

It's a tradition

Every worthwhile feature that has been of advantage to industry has been kept. For example the popular intuitive spin'n'set operating concept working on the basis of the two rotary knobs that give an „analog feeling“. The instrument gain and the required functions are always directly accessible. A lot of attention was paid to clarity when arranging functions and menus:

- Simple to use, quick to operate, from basic to challenging inspection requirements.
- From high frequency inspections for thin materials up to low frequency for attenuative materials
- From automotive, power generation, oil and gas to aerospace applications

Additional DAC functions

Recording reference echoes in DAC mode will be simplified by automatic gain adjustment. The echo to be recorded will be set automatically at 80 % and stored. The dB-difference to the first reference echo can be displayed, if needed. The new JIS-DAC meets the latest JIS Z3060-2002 specifications.

Data reporting

800 datasets enable a great number of calibration settings and test results to be stored. Each report can be documented with a memo field containing 6 dedicated areas with up the 24 characters and 3 numerical fields (flaw coordinates) for inspection reports and settings. The report or setting can be printed directly via a RS-232 or up/downloaded to a computer using an RS-232 or USB (with USB-RS accessory).

All three versions may be additionally extended by the Data Logger option: this enables you to use the USM 35X for recording and documentation of 5,000 readings (sound path, amplitude, etc.) and 500 A-scans at the same time. Moreover, you have a third gate, a tolerance monitor and a minimum reading capture at your disposal.

Three different time of flight measurements

Depending on the time of flight mode selected, the distances (measurement carat ▽ red triangle) and amplitudes (carat Δ) will be measured and displayed for the echo in each gate. The measurement points are indicated by the color coded carats for each gate.

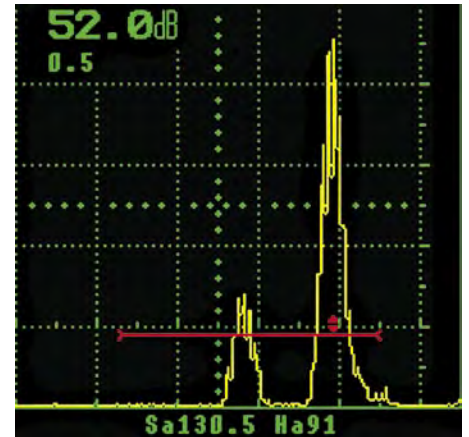

Peak: sound path and amplitude at the highest echo in the gate

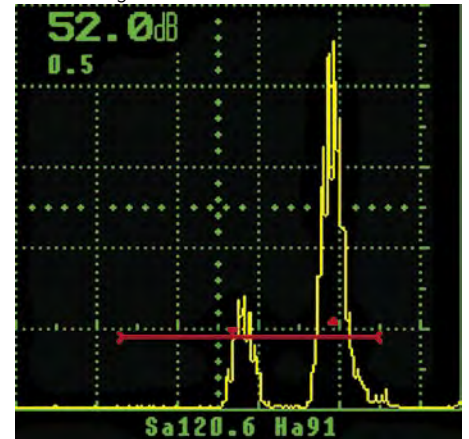

Flank: sound path at the intersection of the first echo with the gate threshold; amplitude at the highest echo in the gate

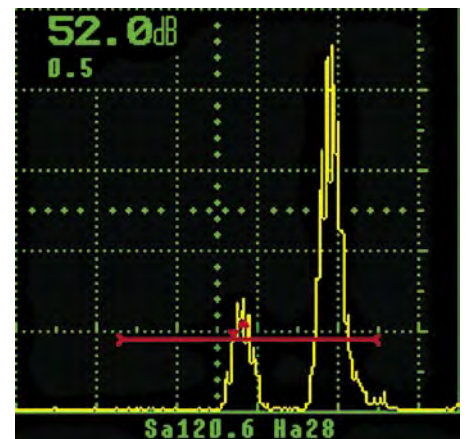

JFlank: sound path at the intersection of the first echo with the gate threshold; amplitude at the first echo in the gate

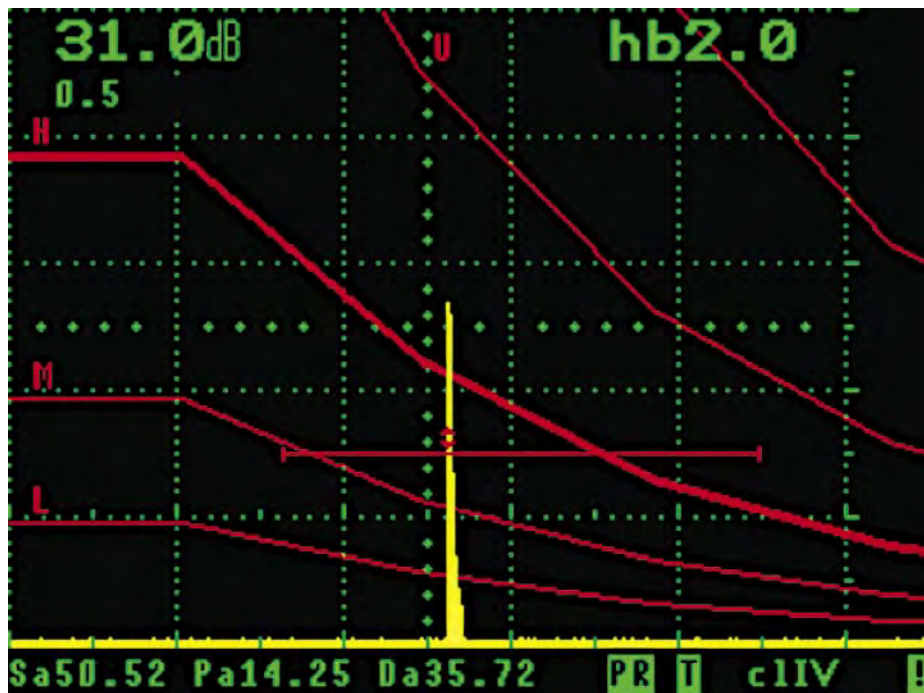

New DAC function according to the latest JIS Z3060-2002 specifications

Examples for the various applications of the high performance and light Krautkramer USM 35X.

Weld inspection in the power generation and petrochemical industries

- Flaw location with display of **all coordinates**, sound path, (reduced) surface distance, depth position and leg number

Sa57.64 Pa49.91 Da21.16 La2

- Display of every sound beam reflection (number of half skip distances or legs) and identification of **leg color** on the "live" A-scan

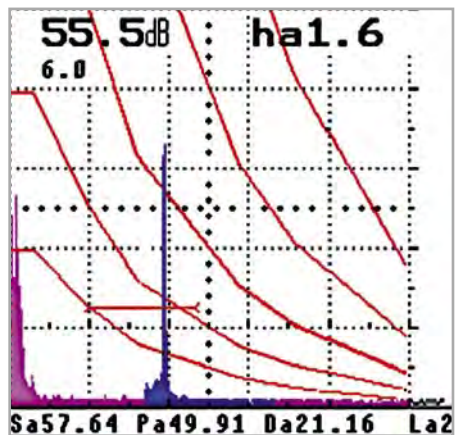

- New powerful DAC/TCG with JIS DAC module according to JIS Z 3060-2002

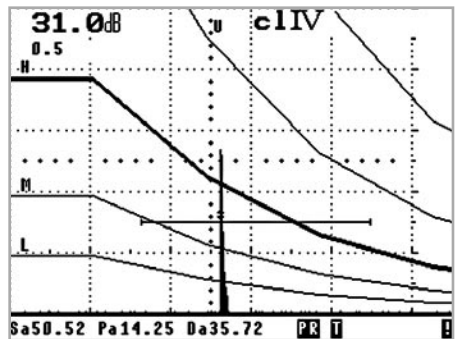

- DGS evaluation with direct digital ERS readout (USM 35X)

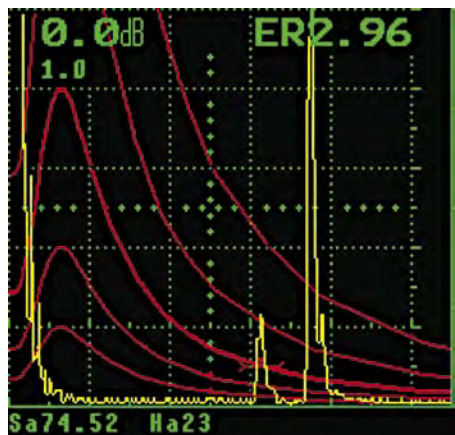

Inspection of a weld

- Amplitude evaluation in dB referring to a previously recorded reference echo or according to **AWS D1.1**

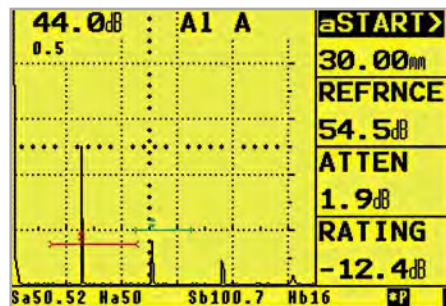

Precise thickness measurement for the automobile industry

You can measure the sound path difference precisely at the peaks of an echo sequence with a resolution of 0.01 mm / 0.001 inch. In doing this, trigger the gates at the 1st backwall echo: this automatically positions gates correctly for the measurement.

Corrosion wall thickness in the power generation and petrochemical sectors

During wall thickness measurement on corroded parts using dual element

probes, you simultaneously check the reading together with the A-scan, thus receiving the maximum reliability for the measurement. On hot surfaces you use the auto-freeze function, minimizing the probe's contact time. The minimum capture mode gives you the thinnest measured reading at the end of a continuous scan.

Inspection of forgings in the power generation and aerospace sectors

The manual setting of the pulse repetition frequency down to 4 Hz eliminates phantom echoes while inspecting fine grain and large work pieces. Defects from an equivalent reflector size 0.3 mm onwards will be detected.

Inspection of special materials in the aerospace and automobile industry

Use probes down to 250 kHz in order to penetrate highly attenuative or composite materials. Our composite probes on the USM 35X will drastically improve the signal-to-noise ratio on sound scattering materials (glass or carbon reinforced plastics, composites or alloys).

Krautkramer USM 35X

Universal Ultrasonic Flaw Detector with Bright Color Display and protected according to IP 66

Specifications:

Calibration ranges

Min.: 0 to 0.5 mm +10 % (steel),
0 to 0.02" +10 % (steel)
Max.: 0 to 9,999 mm +10 % (steel),
0 to 390" +10 % (steel) within
the frequency range from 0.2
to 1 MHz / 0.5 to 4 MHz
0 to 1,420 mm +10% (steel),
0 to 56" +10 % (steel) within
the frequency range from 0.8
to 8 MHz / 2 to 20 MHz

Sound velocity

1,000 to 15,000 m/s, 40 to 600 inch/ms variable
in steps of 1 m/s, 0.1 inch/ms
and fixed programmed values

Display delay

From -10 to 1,000 mm, -0.3 to 40" (340 μ s)

Probe delay

0 to 200 μ s

Auto calibration

Measurement and setting of sound velocity and
probe delay using two known calibration echoes
(2-point calibration)

Pulse intensity

220 pF, 1 nF

Damping

50 ohms, 500 ohms (1,000 ohms in TR mode)

Pulse repetition frequency

4 to 1,000 Hz, variable in 10 steps

Frequency ranges (-3 dB)

0.2 to 1 MHz / 0.5 to 4 MHz / 0.8 to 8 MHz /
2 to 20 MHz

Gain

0 to 110 dB, variable in steps

Gain steps

0.5 / 1 / 2 / 6 / 12 dB (or user-adjustable),
step 0 is locked

Fine gain

4 dB, continuously variable in 40 steps

Rectification

Full-wave, negative and positive half-wave,
RF mode

Reject

Linear, 0 to 80 % screen height
Variable in steps of 1 %

Monitor gates

2 independent gates in color bar mode, start and
width variable over the entire calibration range,
response threshold of 10 to 90 % screen height
variable in steps of 1 % (coincidence and anti-co-
incidence), alarm signal via LED and connectable
internal horn, Gate A switchable as interface gate
for Gate B, gate magnifier (zooming of gate range
over the entire display range)

Sound path measurement

Digital display of sound path (projection distance,
depth) between initial pulse and the first echo in
the gate, or between the echoes in the two gates,
measurement always at the intersection point
with the echo flank or echo peak

Measurement resolution

0.01 mm within a range up to 99.99 mm/
0.1 mm within a range from 100 to 999.9 mm/
1 mm above 1,000 mm,
0.001" within a range up to 9.999"/
0.01" above 10"
With evaluation in the frozen A-scan: 0.5 % of the
calibration range setting

Amplitude display

In % screen height
USM 35X DAC: additionally in dB above DAC or TCG
USM 35X S: additionally in dB above DGS curve
or ERS

Displayed reading

Sound path, (reduced) projection distance, depth,
amplitude for every gate, user-
configurable at four positions of measurement
line and of the zoomed display in the A-scan

A-scan functions

Manual or automatic A-scan freeze,
A-scan comparison, echo dynamics
(envelope), peak echo storage

Color functions

Patented color-coded display of legs in angle
testing, adaptation of background color to the
light conditions of test environment, color display
of monitor gates and of registration curves (DAC,
TCG, DGS) for direct recognition, messages and
alarms in red characters



DAC / TCG (Option)

Only USM 35X DAC and USM 35X S: Distance-Amplitude Curves (DAC) or TCG line (TCG) with a maximum of 10 reference echoes, 4 other curves or lines can be displayed with variable dB intervals. JIS DAC can be selected in order to allow inspection according to JIS Z3060-2002 (Japanese Inspection Standard). Automatic gain control during DAC recording.

DGS (Option)

Only USM 35X S: DGS curves for single-element and dual-element probes (B1S, B2S, B4S, MB2S, MB4S, MB5S, WB...-1, WB...-2, SWB...-2, SWB...-5, MWB...-2, MWB...-4, SEB and MSEB) and for all materials, sound attenuation and transfer loss correction, 4 other curves can be displayed with variable dB intervals

Display size / resolution

116 mm x 87 mm, 4.6" x 3.4" (W x H)
320 x 240 pixels

A-scan size / resolution

116 mm x 80 mm, 4.6" x 3.2"
320 x 220 pixels (zoom)

Units of measurement

mm, inch

Data memory

800 instrument setups or reports, including A-Scans can be stored, recalled, printed or exported to a computer.

Direct documentation

Display screen contents, report including A-scan, reading, function list (parameter dump)

Printer driver

HP DeskJet, HP LaserJet, HP DJ 1200 (DeskJet)
HP LJ 1012 (LaserJet), EPSON FX/LX, SEIKO DPU

RS 232 interface

9-pin DSUB, bi-directional, 300 - 57,600 baud
An USB adaptor cable can be provided to connect the USM 35X to a computer that does not have RS 232 port

Input/Output

8-way Lemo-1 socket (trigger output, gate alarm, test data release)
Additional analog output for amplitude or sound path in selected gate

VGA output

10-way Lemo-1 socket for the connection of an external display screen or beamer

Probe connections

2 x Lemo 1 or BNC

Dialog languages

German, English, French, Italian, Portuguese, Spanish, Danish, Swedish, Norwegian, Finnish, Czech, Slovenian, Romanian, Dutch, Croatian, Hungarian, Russian, Polish, Slovakian, Japanese

Battery operation

Li-ion battery or 6 C-cells (NiCad, NiMH or AlMn), operating time: 14 hours with Li-ion battery (6.6 Ah), approx. 3 hours with NiMH cells (3 Ah), battery charge check by an icon in the measurement line

Power pack/ battery charger operation

Via an external power supply (85 to 265 VAC);
Operating voltage: 6 to 12 VDC
Current consumption: max. 9 W, depending on the setting

Weight

2.2 kg, 4.9 lbs., including batteries

Size

177 mm x 255 mm x 100 mm,
7.0" x 10" x 3.9" (H x W x D)

Environmental

Protection class: IP 66
Shock proof acc. to DIN IEC 68: 6 ms, 60 g,
3 shocks per orientation
Vibration proof acc. to DIN IEC 68: 0 - 150 Hz, 2 g,
20 cycles per orientation
Operating temperature: 0° to 60°C; 32° to 140°F
(-10°C; 14°F on special request)
Storage temperature: -20° to 60°C; 4° to 140°F

Data Logger Option

Memory capacity

5,000 readings, 500 A-scans for the readings,
100 jobs, 10 comment texts per job

Storable readings

Sound paths and sound path differences of all gates, amplitudes (% SH, dB-to-threshold, dB-to-curve, %-to-curve, ERS), alarms of all gates or tolerance monitor

Lines / columns

Number of lines: maximum 5,000 (Linear file with one column), numerical indexing
Number of columns: maximum 26,
indexing: A, ..., Z

Tolerance monitor

Lower and upper acceptance level with monitor function

Minimum reading capture

Storage of the minimum value measured in continuous scanning, display of the value 3 seconds after uncoupling the probe

Monitor gate

1 additional independent gate in color bar mode

Krautkramer USLT 2000

The Ultrasonic Test System
in a Notebook for Today and Tomorrow

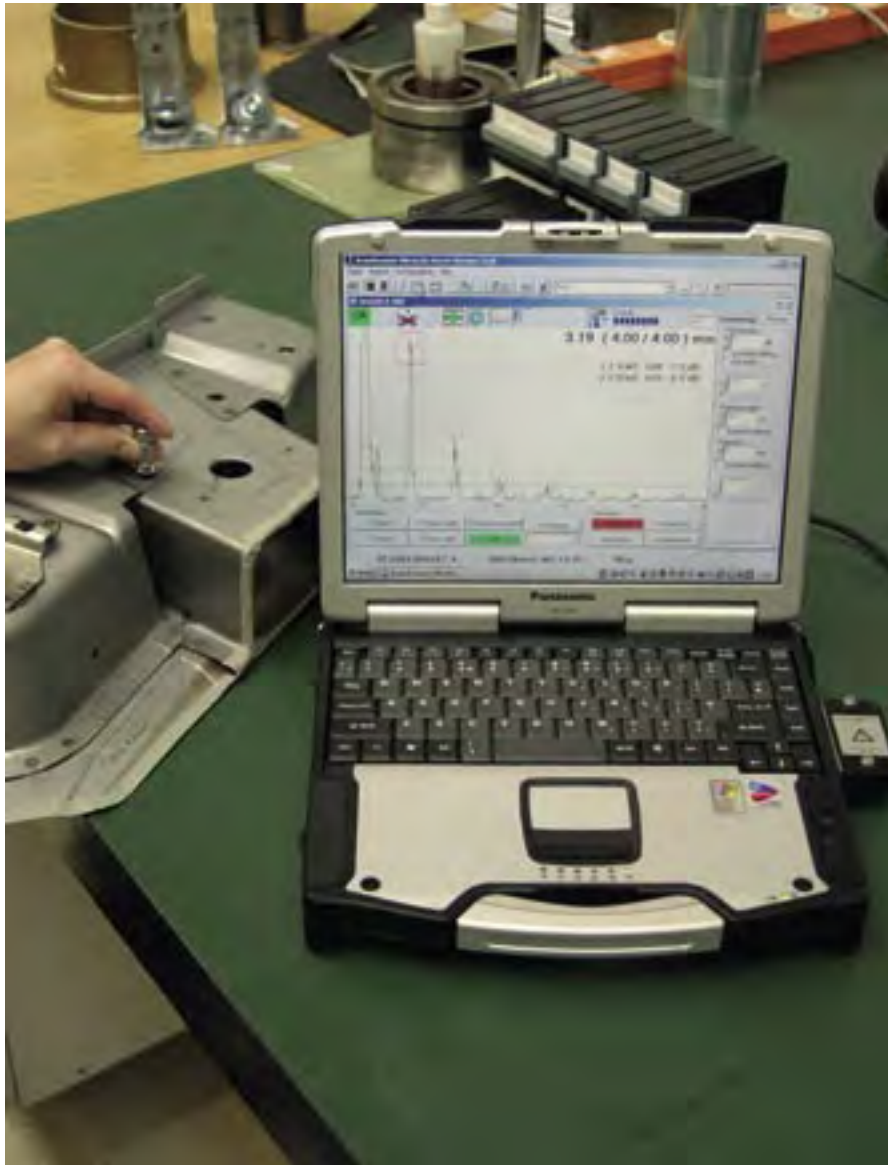

GE imagination at work



For mobile test use, first-rate documented ultrasonic performance

The demands on ultrasonic tests are changing - and with them also the technical prerequisites for fulfilling new needs and requirements. We keep pace with the development: our USLT 2000 provides you with state-of-the-art technology that multiplies the application possibilities in everyday testing - and maintains a perfect ease of use. The advantages for the Quality Management are also obvious: the USLT 2000 solves all your problems with the management, evaluation and exchange of test-relevant data.

For everyday testing ...

Ultrasonic testing with a notebook means: high-tech ultrasonics *plus* modern data management *plus* mobility.

The USLT 2000 stands for excellent ultrasonic performance to accomplish even the most demanding test tasks. It stands for the openness toward the EDP world because the complete Windows functionality is utilized. In the end, the USLT 2000 stands for a truly mobile use: a PC weighing just about 3 kg (6.6 lbs.) becomes a universal ultrasonic instrument able to withstand - as an industrial-type notebook - even adverse ambient conditions.

For the Quality Management ...

Ultrasonic testing using a mobile notebook also means: undreamt-of possibilities for data processing.

Documentation of ultrasonic tests and test results, Export to Microsoft Excel, forwarding of data to company databases and networking of test systems - the USLT 2000 paves the way in today's and tomorrow's world of data.

... Krautkramer technology

This advancement was made possible by the cheque card-sized PCMCIA card especially developed by Krautkramer and taking care of the complete digitization of the test system.



Test technology for special demands

The pick of ultrasonics

Extreme miniaturization of the electronics and maximization of performance - that's USLT 2000.

The system is not only characterized by a high measuring accuracy and a large frequency range but also by extensive matching features enabling you to tailor the USLT 2000 to your individual application needs.

This includes for example the choice of the echo display mode that helps you with the evaluation: you can superimpose a stored display of test findings on the currently active A-scan in order to compare the test results. You can alternatively record the echo dynamics and simultaneously display the real-time signals. Even the possibility of an adjustable signal averaging is available to you in this connection.

The USLT 2000 offers universal evaluation options for detected indications to meet both national and international test specifications: DGS curves, user-friendly recording of a DAC and TCG for both methods.

A highlight: the A-scan

With the USLT 2000, the days when you missed the analog screens of the usual test instruments in some test jobs are gone because the SVGA screen achieves a maximum A-scan resolution of 635 x 400 pixels thus enabling an almost analog display. Added to this are the large color display and the fast echo display.

The Windows operator interface with A-scan and setup menu. Dialog language and units can be easily changed.

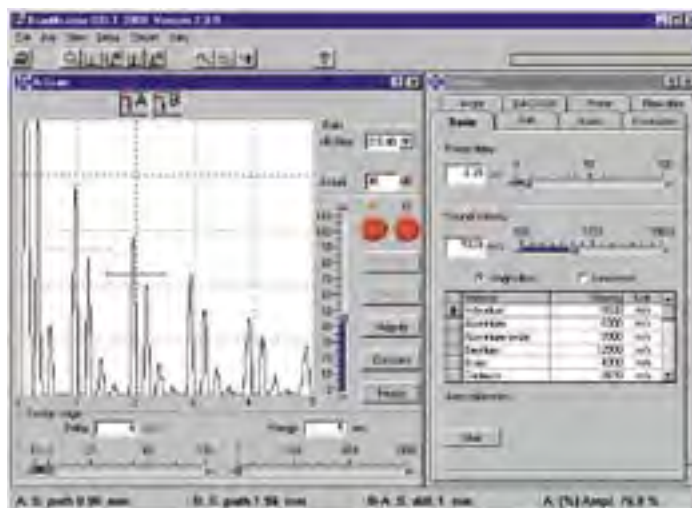

The operator interface with A-scan in zoom mode, echo comparison, multiple DAC and display evaluation

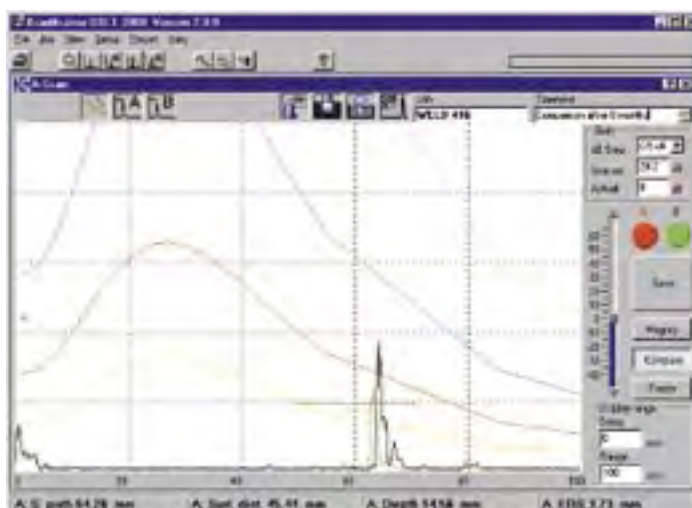

This makes the USLT 2000 even suitable for applications in which an excellent resolution is important: for example, bonding tests and flaw detection on thin work-pieces, or in particular the inspection of spot-welded joints, for instance within the automotive industry.

An operator-interface, especially tailored to this application, automatically carries out spot weld evaluation and stores all the results in the database.

The probe solution

The pulser and receiver electronics is accommodated in a small aluminium box. Just select the probe required for your test task and connect it.

The intelligent Krautkramer dialog probes provide a special ease of use because they are automatically recognized by the system. All important probe data are automatically transferred to the USLT 2000.

EDP technology to make life easy for you

The Windows interface

With the clear and well-arranged graphical Windows interface, in four languages, you will have no problem with the system handling. The system is operated via keyboard, an integrated touchpad, an optionally connected mouse or via a remote control having eight assignable instrument functions.

The Windows world

As the USLT 2000 is a standard PC, you can of course also install other Windows applications and use them for your individual applications parallel to the ultrasonic functionality. This means that if you're not using the USLT 2000 as an ultrasonic instrument, you can, for example, also work with word processing and spreadsheet programs.

You will learn to appreciate the advantages made available by the Windows world with its entire functionality even more. The so-called "multitasking" - that means simultaneous application of several programs and exchange of all sorts of data - offers great ease of use in this regard. In view of working with the USLT 2000, this means: you generate your test report forms in MS Excel. After this, you determine the fields into which the parameters and readings from the test results of the USLT 2000 are to be transferred. All you then have to do is select the test jobs and results which you wish to file and the forms are automatically filled out and ready to be printed.

Database

The storage of test data is indispensable not only for repetitive in-service tests. The importance of documentation also ranks enormously high today.

Instrument settings for different applications as well as countless test results, including the A-scans, must be permanently filed or statistically evaluated in many ultrasonic tests for reasons of product liability.

The method best suited to accomplish this task is a well-structured database: in the USLT 2000, all settings and findings are stored and managed in a MS ACCESS database.

Application software

The openness of the Microsoft concept offers all the possibilities of an individual postprocessing of data here as well because the most different programs have access to the filed data: analyzing programs, programs for test job management, and not forgetting - the tailored Krautkramer application software.

All USLT 2000 utilities (functions, function values and readings) are freely available to the user and can be applied for development of own test and control programs, together with the UltraWorks program.



Excel export of inspection results

Krautkramer USLT 2000

The Ultrasonic Test System in a Notebook for Today and Tomorrow

Specifications

Calibration ranges

min.: 0 - 2.5 mm; 0 - 0.1" (steel)
max.: 0 - 9700 mm; 0 - 381" (steel)

Sound velocity range

500 - 15000 m/s; 0.02 - 0.59 "/ms
integrated, editable material table

Pulse shift

-10 - 1500 mm; -0.39 - 50" (steel)

Probe delay

0 - 100 μ s

Damping

50 ohms / 500 ohms; 1000 ohms with Dual or
Through-Transmission modes

Intensity

220 pF / 1 nF

Frequency range

0.5 - 20 MHz (-3 dB); 4 filter ranges

Pulse repetition frequency

1-1000 Hz, automatically or manually adjustable

Gain

110 dB, adjustable in steps of 0.5 / 1 / 2 / 6 dB

Operating modes

Pulse-Echo, Dual, Through-Transmission

Rectification

full-wave, positive half-wave, negative half-wave, RF
display (up to 150 mm/5.9" steel)

Suppression

0 - 90 % linear

DAC/TCG

DAC with up to 16 curve points (reference reflectors),
dynamic range 37 dB, maximum slope 6 dB/ms;
3 additional curves at adjustable dB distances, can
be changed to TCG (Time-Corrected Gain) mode
(horizontal recording threshold); meets national and
international test specifications

DGS

recording curves for all valid equivalent reflector sizes
and probes with DGS capability; setting as DAC or TCG;
evaluation in dB related to curve, ERS or class (JIS);
sound attenuation and transfer correction; reference
reflectors used: backwall, circular disk reflector and
side-drilled hole

Monitor gates

2 independent monitor gates, adjustable over the entire
maximum calibration range; evaluation on the basis of
A-scan at display refresh rate; gate alarm: off, coinci-
dence, anticoincidence; visual and/or acoustic alarm

Distance measurement

individually selectable for each gate at the echo flank
or peak, in the RF mode addition-ally at the zero
transition of the increasing or decreasing echo flank

- initial pulse and measurement point in
gate A or B
- measuring points: gate B - gate A
(differential measurement)

Measurement resolution

sound path/time of flight: up to 12.6 mm: 0.01 mm;
otherwise 0.2 % of display width

Amplitude

0.5 % screen height or 0.2 dB

A-scan digitization

1024 x 1024 pixels

Display freeze

static A-scan freeze, dynamic A-scan freeze (peak
value, echo dynamics + real-time signal), average
freeze via 2 to 32 ultrasonic pulse cycles

Echo comparison

simultaneous display of the currently active signal and
a stored A-scan

Outputs

documentation via standard interfaces of the notebook

Inputs

2 analog inputs, e.g. for probe coordinates,
digitization with 10 bits each

Dialog languages

German, English, French, Spanish and Italian

Units

mm, inch, μ s

Probes

standard and dialog probes (automatic recognition)
can be connected

Data storage

database for storing and managing instrument
settings, test jobs and test results, including A-scan,
DAC and alphanumeric comments, Export to
Microsoft Excel; limited only by the hard disk size

Software

operating system: Windows2000/XP; Client-Server
interface OLE 2.0; options: UltraWORKS (design tool),
FFT (Frequency analyses)
EHT (hardening depth), RTM (resonance thickness
measurement with 1 μ s resolution), UltraLOG
(evaluation program for spot weld testing)

Notebook versions (trademarked units)

standard or industrial version (IP 52)

Mains and battery operation

approx. 5 h, depending on the processor workload

Operating temperature

5 °C - 45 °C; 41 °F - 113 °F (standard)
0 °C - 50 °C; 32 °F - 122 °F (industrial)

Dimensions (H x W x D)

63 mm x 300 mm x 230 mm;
2.5" x 12" x 9" (standard)
64 mm x 302 mm x 273 mm;
2.5" x 11.9" x 10.7" (industrial)

GE imagination at work



KRAUTKRAMER USLT 2000B

The proven and tested ultrasonic notebook as a PC-based instrument



Test your joins non-destructively with ultrasound!

The variety of jointing methods used in automotive welding and assembly lines has significantly increased in the last few years. While a few years ago resistance-welding and MIG/MAG welds were the favoured joining methods, nowadays laser welding/soldering, bonding, etc. are preferred.

Since all of these procedures are more and more used complementarily (best fit), a lot of great demands have been made on the test engineering.

Instead of destructive testing of welding spots, for instance with a hammer and chisel, in recent years non-destructive testing with ultrasound has become more and more prominent. The continually increased acceptance of this procedure is last but not least due to the fact that GE Inspection Technologies, co-operating with industry, has made substantial contributions to the technical progress.

All well-known car manufacturers already work successfully with these innovative systems.

USLT 2000B ultrasonic instrument

GE Inspection Technologies is constantly advancing its products and testing solutions, and has developed the new USLT 2000B portable ultrasonic instrument for testing welding spots with ultrasound, in particular for meeting the requirements of the automotive industry. The key features comprise:

Mobile use:

This light, battery-driven ultrasonic test system is recommended for local application, e.g. in production plants. The large TFT screen allows test data to be read easily from significant distances.

Easy handling:

The USLT 2000B distinguishes itself by an ergonomic user interface. The built-in touch screen and the 14 programmable function keys considerably simplify the operation.

A variety of outputs:

The standard interfaces, such as LAN, USB and VGA, allow the instrument to be connected with all known tools from the office world.

From one source you will receive software packages for ultrasonic testing instruments for easy monitoring of joins.

Constant readiness for the future by virtue of productivity, quality and security is and remains a special characteristic of our technology for testing solutions.



Creation of inspection plans with the Database Manager

The Database Manager contains an entire database system for the creation and administration of the testing records. You can plan, control and document your testing, for instance by

distributing world-wide via E-mail testing records tuned to the structure of your manufacturing process.

Test with the UltraLOG program

With our application software the evaluation of the welding spots is automated to a large extent. During the

testing, which follows an individual test plan, the program delivers a proposal for evaluation.

UltraLOG carries on with testing when the operator has accepted the result. The results are automatically documented, too.

Technical data

Adjustment ranges

min.: 0 - 2.5 mm (steel)
max.: 0 - 9,700 mm (steel)

Range of sound velocity

500 - 15,000 m/s
integrated editable table of materials

Pulse shifting

-10 mm - 1500 mm (steel)

Probe delay

0 - 100 ms

Damping attenuation

50 Ohms / 500 Ohms; 1000 Ohms when used as double transducer probe or in transmission

Pulse strength

220 pF / 1 nF

Frequency range

0.5 - 20 MHz (-3 dB); 4 filter ranges

Pulse repetition frequency

1-1000 Hz, adjustable automatically or manually

Amplification range

110 dB, adjustable in steps of 0.5 / 1 / 2 / 6 dB

Modes of operation

Pulse Echo, as double transducer probe, transmission alignment, one way positive, one way negative, R.F. representation (up to 150 mm steel)

Suppression

0 - 90 % linear

Depth compensation

DAC with up to 16 reference reflectors, dynamic range of 37 dB, maximum slope of 6 dB/ms; Three additional curves with adjustable dB-intervals, convertible as depth compensation (horizontal recording level); satisfies national and international testing regulations

DGS

Recording curves for all valid replacement reflector sizes and probes suitable for DGS; adjustment to DAC or depth compensation; evaluation in dB to the curve, ERG or class (JIS); sound attenuation

and transfer correction; applicable reference reflectors: back wall, disc-shaped reflectors and cross holes

Monitor gates

Two independent gates, adjustable across the whole adjustment range; evaluation from the A-scan with frame repetition rate; gate alarm: off, coincidence, anticoincidence; - optic and/or acoustic alarm

Range finding

Individually selectable for each gate at the echo edge or peak in R.F. presentation, and additionally at the zero crossing of the leading and trailing edges of an echo

- Original pulse indication and check point in gate A or B

- Check points: gate B - gate A (differential measurement)

Measurement resolution

Sound path / delay up to 12.6 mm: 0.01 mm; or 0.2 % of the screen width

Amplitude display

0.5 % of screen height or 0.2 dB

A-scan digitising

1024 x 1024 pixels

Image storage

A-scan freeze static, A-scan freeze dynamic (peak value, echo dynamics and real-time signal), average from 2 to 32 ultrasonic shots

Echo comparison

Simultaneous display of the current signal with a saved A-scan

Outputs

Documentation on the existing standard interfaces of the ultrasonic instrument

Conventional languages

German, English, French, Spanish and Italian

Measurement units

mm, inches, μ s

Probes

Connection of standard and dialogue probes (automatic recognition)

Interfaces with PC

4 x USB 1.1
Ethernet TCP/IP 10 MBd
Monitor SUB-D 15 pol.

Data storage

Database for the storage and administration of instrument settings, test jobs and test results with A-scan, DAC and alphanumeric commentary, export to Microsoft Excel; limited only by size of hard drive

Software

Operating system: client-server interface OLE 2.0; optional: UltraWORKS (development tool), FFT (Fast Fourier Transformation), EHT (Effective Hardening Testing), RTM (Resonance Thickness Measurement 1 μ s resolution), UltraLOG (evaluation program for welding spot testing), UDB Manager (creation of inspection and test schedules) 12,1", TFT, SVGA touch-screen

Display

12.1" TFT, SVAG touchscreen

Battery operation

Approx. 4 h, depending on load on the processor

Operating temperature

0 °C to 40 °C

Dimensions (H x W x T)

390 mm x 374 mm x 155 mm

Weight (incl. 1 battery)

6.7 kg

Options

USLT 2000B	USLT software
USLT 2000BP3	USLT software + UltraLOG
USLT 2000BA3	USLT software + UDB-Manager + UltraLOG

Krautkramer UltraDOC

On the safe side
with your documentation

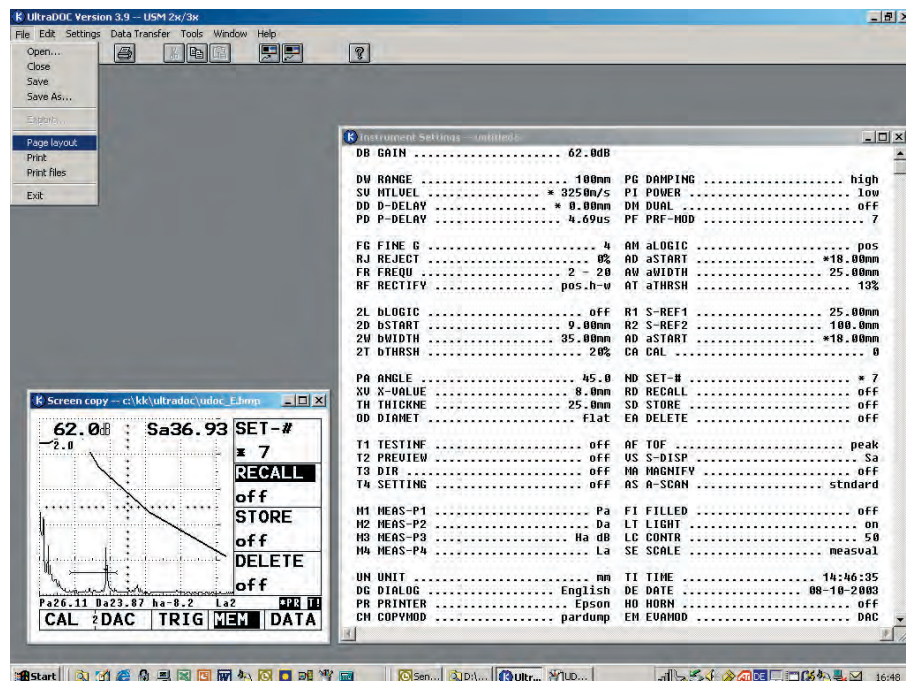

The value of today's quality assurance tests depends on the quality of the corresponding documentation. You know the statutory provisions: in the case of damage, an objective proof of all measures that had been taken for the quality assurance of a product must be furnished.

Test instruments in combination with the UltraDOC software provide you with the required safety because UltraDOC makes the documentation process considerably easier.

UltraDOC allows you to transfer test data from the test instrument to the PC (for example parameter dumps, A-scans, menus) and to store them in usual data formats so that you will be able to further process them as you like. Word processing, DTP or spreadsheet programs - the whole world of EDP is at your feet.

You will have no trouble in creating your test reports and in carrying out the documentation of your test results quickly, reliably and conveniently.

Other documents, such as training documentation or re-research reports, can also be presented in a professional way using UltraDOC. But UltraDOC has a lot more to offer: from the transfer of stored instrument calibrations back to the test instrument, through quick viewing of stored test data on the PC display, up to the remote control of the test instrument.

By using UltraDOC you can:

- transfer instrument settings from the test instrument to a PC, store them as ASCII text and further process them
- transfer any display contents of your choice, store them in IMG, BMP or PCX format and further process them
- store complete instrument settings and calibration tables and transfer them back to the testinstrument
- gain a quick overview of stored test data
- remote control your test instrument.

UltraDOC was developed for a great number of our flaw detectors and other test instruments having an RS232 interface. It is available as Windows version, it only requires standard computer systems, it is easy to install - and even easier to use.

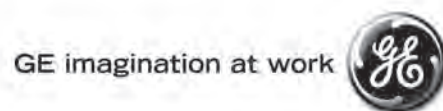



SMALL SIZE. BIG VALUE.

TOPAZ¹⁶ BEST IN CLASS FULLY INTEGRATED 16 CHANNEL PHASED ARRAY UT DEVICE



Best in Class Productivity

Since its launch, TOPAZ® has set a new standard for portable Phased Array unit performance. Now the TOPAZ family gets bigger. Introducing TOPAZ¹⁶, the best in class, fully integrated 16 channel phased array UT device. TOPAZ¹⁶ delivers big value in a small footprint offering best-in-class features including:

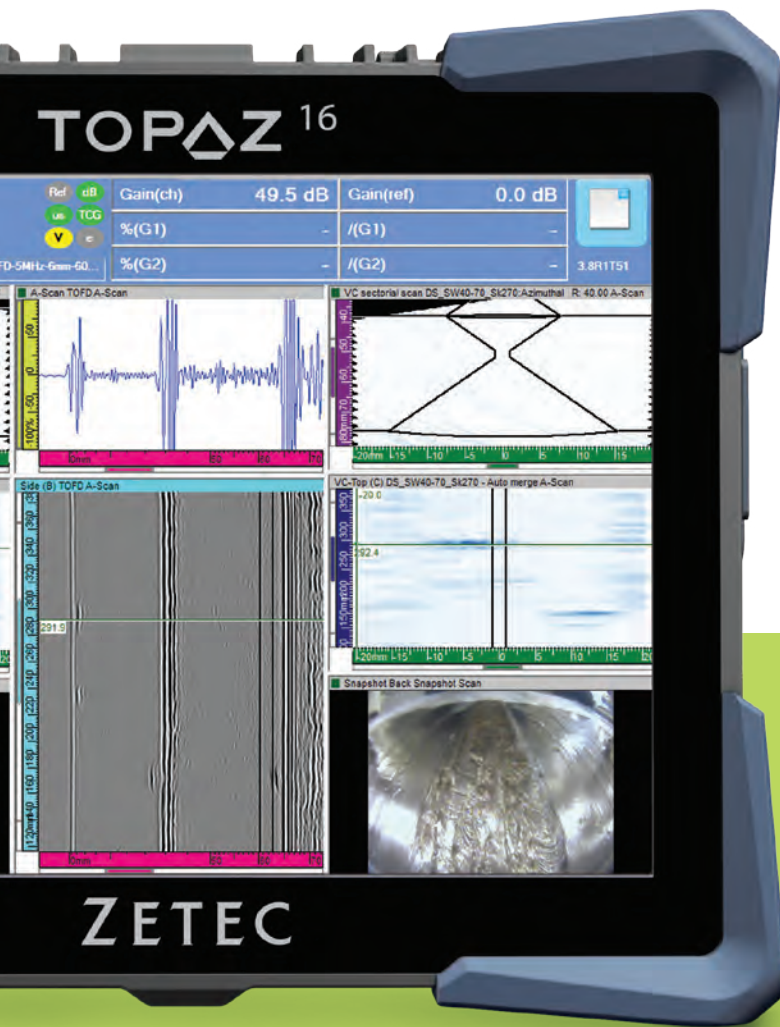

ULTRAVISION

COMPLETE UT AND PHASED ARRAY INSPECTION PACKAGE

- **UltraVision® Touch software embedded.** TOPAZ¹⁶ includes UltraVision Touch software onboard. Leverage one single software platform across the entire family of UT products. Benefit from powerful features including:
 - Embedded advanced focal law calculator with visual feedback
 - Onboard volumetric merge and measurement tools
 - Interactive help onboard the instrument
 - Remote control capability with UltraVision Touch
- **Best in class operating temperature range for added flexibility.** TOPAZ¹⁶ is built to meet your specific demands regardless of the environment.
- **Multi-probe and multi-group support.** With the 16/128 version, weld inspections are easy by simply adding a probe splitter accessory. The 16/64 version offers multi-group support (one probe type at a time).
- **10.4" high resolution multi-touch display.** TOPAZ¹⁶ features a very wide, highly responsive multi-touch screen that offers the best resolution in its class.

HANDLES APPLICATIONS WITH EASE

TOPAZ¹⁶ is sized for convenience and built to perform. With proven Zetec quality and innovation, TOPAZ¹⁶ is ideal for the most common inspection applications including:

- Weld inspection
- Corrosion mapping
- Encoded or manual inspection
- Inspection of complex components and more

Unmatched Value

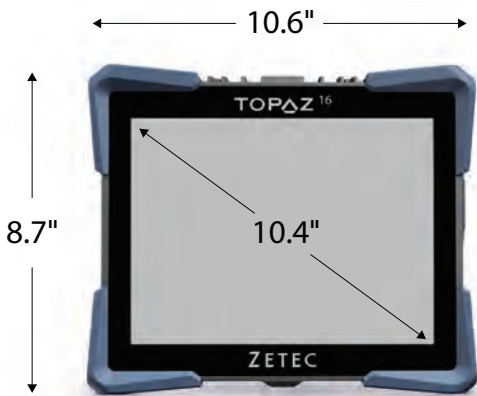

Big Screen. Small Footprint.

Delivers a Fully Integrated Inspection Process. TOPAZ¹⁶ is capable of handling all steps in an inspection process helping to lower costs:

Preparation: Specimen editor and focal law calculator means easy setup

Acquisition: Features that deliver a highly efficient data acquisition process

Analysis: Full suite of basic and advanced analysis tools onboard

Reporting: Ready to print standard or custom reports in a touch

Built to Go Anywhere. TOPAZ¹⁶ is compact and lightweight in a robust aluminum casing with no air intake. The full metallic housing improves robustness, thermal transfer efficiency and weighs only 4.5 kg (10 lb).



1 Dedicated UT Channel. A separated conventional UT channel offers 200V (at 50Ω) pulser and works in P/E or P/C configurations for TOFD examinations.

More Uptime with a Hot Swap Battery Capability. Designed to accommodate two batteries in a hot swappable sequential discharge configuration.

Fast and Safe Data Transfer. TOPAZ¹⁶ features an internal solid state drive (SSD) for quick, reliable data transfer and storage during operation.

High Signal Quality and Less Chance of Saturation. Digitizing up to 800% and 16-bit amplitude resolution.

Easy, Seamless Setup with Zetec Probes and Scanners. When any Zetec scanner such as NDT PaintBrush, Weld Crawler or probe is connected, TOPAZ¹⁶ automatically recognizes and preconfigures the inspection sequence accordingly, saving valuable time. Also works with other scanners and probes.

More Flexibility to Meet Your Needs. TOPAZ¹⁶ offers multiple scanning configurations: sector, linear and compound.



Numerous Connectivity Options. TOPAZ¹⁶ has the Network Connectivity Options you Need.

- 1 USB 3.0 (10x faster than 2.0), 2 USB 2.0 and gigabyte LAN, HDMI
- UT channel: 1 high-quality UT channel for conventional UT (pulse echo, pitch-and-catch or TOFD)
- Quality PA UT connector with a solid probe latch

Adaptable to Meet Your Needs

TOPAZ¹⁶ Accessories

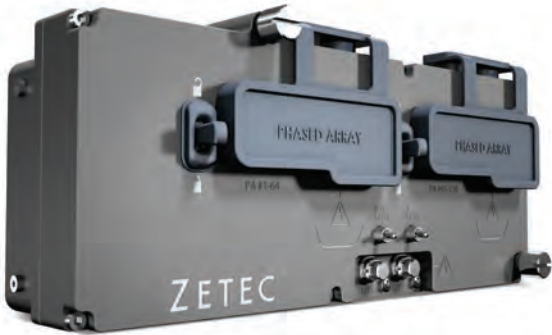

Probe Splitter: connect two PA probes at the same time for dual probe weld inspection configurations. The probe splitter is available in two different versions: ZPAC and Omni type probe connectors.



Fan Kit: extends the temperature operation range of the unit enabling TOPAZ¹⁶ to fully operate in environments where no other instrument in its class can.

Available in Two Versions

- TOPAZ¹⁶ 16/64P
- TOPAZ¹⁶ 16/128P

TOPAZ¹⁶ is future proof: Upgradeable from 16/64 to 16/128 through a software update. No need to send the product to Zetec.

	Feature	16/64	16/128
Configuration	Conventional UT	One Probe Type at a time	Simultaneous
	TOFD		
	Phased Array		

Specifications

FEATURE	TOPAZ 16
Size (H x W x D)	221 x 271 x 120 mm (8.7 x 10.6 x 4.7 in)
Weight (including one battery)	4.54 kg (10.0 lb)
Multi-Touch Display	10.4 in. - 1024 x 728 pixels
Air Intake	No
Battery Operation	Yes
Phased Array Connector	ZPAC
Phased Array Channels	16/128 or 16/64
UT Channels	1 P/E or 1 P/C
Amplitude Resolution	16 bits
Measurement Gates	4 + 1 synchronization gate
Data Interfaces	Ethernet 1000 Base-T 1 x USB 3.0 2 x USB 2.0
Maximum PRF	12 kHz
Data Compression:	1, 2, 4, 8, 16
Max. Pulsed Voltage (Open Circuit)	105V PA UT / 215V UT
Max. Applied Voltage (50 ohms)	75V PA UT / 200V UT
Bandwidth (-3 dB)	from 0.5 to 18 MHz
Rectification	Digital
Filtering	Analog / Digital (FIR)
Smoothing (Video Filter)	Digital
Self-Check	Yes
Automated Probe Detection	Yes (with Zetec probe ID chip)
Automated Scanner Detection:	Yes (with Zetec probe ID chip)
# Focal Laws	256
Maximum Number of Samples	8,192
Maximum Data File Size	300 MB for 16/64 700 MB for 16/128
Encoder Interfaces	2 quadrature-type
Onboard Software	UltraVision Touch embedded
Serves as Protection Key	License for UltraVision Touch
Data Acquisition & Analysis (for remote data acquisition or off line postprocessing)	UltraVision Touch UltraVision 3
Embedded Hard Drive	128 GB SSD
Video Output	HDMI
Instrument Calibration	Compliant with ISO 18563-1 / EN 12668-1

General Specifications

Voltage: 100 to 240 VAC

Frequency: 50 or 60 Hz

Maximum Power: 100 VA

Operating Temperature Range: -10°C to 45°C (14°F to 113°F)

Operating Temperature Range with External Fan Kit:
-10°C to 53°C (14°F to 127°F)

Storage Temperature Range: -40°C to 70°C (-40°F to 158°F)

Relative Humidity: 80% non-condensing

CE mark is an attestation of the conformity with all applicable directives and standards of the European Community. The TOPAZ¹⁶ is an instrument of class 1 and installation category II.

Ordering Information

10053724 - ZPA-IUT-TOPAZ-16/64P-KIT

Fully integrated portable Phased Array system featuring up to 16 active channels on up to 64 element probes. Phased Array probes are connected on a solid Zero Insertion Force secured connector whereas 2 Lemo 00 connectors can be used for pulse echo or TOFD inspections.

10053725 - ZPA-IUT-TOPAZ-16/128P-KIT

Fully integrated portable Phased Array system featuring up to 16 active channels on up to 128 element probes for enhanced inspection capabilities. Phased Array probes are connected on a solid Zero Insertion Force secured connector whereas 2 Lemo 00 connectors can be used simultaneously for pulse echo or TOFD inspections.

System purchase includes: TOPAZ¹⁶ unit with UltraVision Touch embedded, 2 batteries, 1 carrying case, 1 power cable (North America), 1 power cable (Europe), 1 AC adapter, 1 Ethernet cable, 1 USB Flash drive and user manual.

Environmental Tests

As per MIL-STD-810G

Cold Storage - 502.5 procedure I

Cold Operation - 502.5 procedure II

Heat Storage - 501.4 procedure I

Heat Operation - 501.4 procedure II

Temperature Shock - 503.5 procedure II

Vibration - 514.6 procedure I

Transit Drop - 516.6 procedure IV

Drop Test - IEC61010-1

Accessories Ordering Information

10053569 - ZPA-ACC-SPLTBOX16-ZPAC-2ZPAC64+2UT

ZPAC SPLITTER for TOPAZ¹⁶ with fast easy attachment system including a solid security latch. It can manage ID data from 2 Phased Array probes allowing UltraVision to track them. It includes one pair of Lemo connectors (individually isolated with switches) to convert Phased Array lines into one Conventional Channel.

10053781 - ZPA-ACC-SPLTBOX16-ZPAC-2OMNI64+2UT

Omni type SPLITTER for TOPAZ¹⁶ with fast easy attachment system including a solid security latch. The splitter includes one pair of Lemo connectors (individually isolated with switches) to convert Phased Array lines into one Conventional Channel.

10053374 - ZPA-ACC-TOPAZ16-FANEXT-ASSY

Fan Kit for TOPAZ¹⁶. It extends the instrument operating temperature range. Easily attached at the back of the unit without any tools and automatically controlled by TOPAZ¹⁶.

FOR MORE INFORMATION ABOUT TOPAZ¹⁶ OR OTHER ZETEC PRODUCTS
CONTACT US AT info@zetec.com OR VISIT www.zetec.com.



Zetec holds ISO 9001
and ISO/IEC 17025
certifications





TOPAZ³² FULLY INTEGRATED PHASED ARRAY UT
DEVICE WITH MULTI-TOUCH SCREEN

PERFORMANCE AND PRODUCTIVITY REDEFINED



SINCE ITS LAUNCH, TOPAZ HAS SET A NEW STANDARD FOR PORTABLE PHASED ARRAY UNIT PERFORMANCE. THE NEW TOPAZ³² REDEFINES PRODUCTIVITY, MAKING IT A SMART INVESTMENT.

TOPAZ³² DELIVERS SPEED AND ONBOARD PROCESSING POWER TO ALLOW FOR LARGER ONBOARD DATA FILES, FASTER ANALYSIS AND SPECIAL NEW TOOLS. PLUS, TOPAZ NOW SUPPORTS 2D DUAL MATRIX PROBES.



Run it with a touch

A revolutionary user experience. Interaction is very intuitive and similar to a smartphone or tablet. Navigate the interface easily, smoothly and efficiently.



Ultra-bright multi-touch display

The high-resolution, ultra-bright multi-touch display can be used indoors or outdoors. Resolution is 64% better than standard displays. The optimized format offers 33% more surface than 16:9 displays with the same diagonal. The dedicated outdoor setting delivers amazing visibility.



Faster Processing Time

New 64 bit onboard computer delivers extra computing power and reduces processing time by a factor of two improving operation fluidness of the instrument.



No air intake

The TOPAZ³² housing is designed so there is no air intake. The removable external fan optimizes heat dissipation. The closed housing design prevents dust, humidity or contamination from getting inside, making it a true field-ready instrument.



Portability

Weighs only 6 kg in a robust magnesium housing.



Connectivity

Connectivity ports 1 USB 3.0, 3 USB 2.0 and gigabyte LAN.

UT channels 2 high-quality UT channels for conventional UT (pulse echo, pitch-and-catch or TOFD).

Quality PAUT connector with a solid probe latch Features a robust connector for fast, easy and low-noise probe connections with a secure, solid latch.

FULLY-INTEGRATED INSPECTION PROCESS

1

PREPARATION

The visual feedback of the on-board shape editor and advanced focal law calculator allows easy setup creation and optimization. Setups for 1D or 2D probes can be created using TOPAZ³² embedded tools.



2

ACQUISITION

The calibration process is made easy with a complete calibration tool. Superior hardware specifications allow for the most efficient encoded data acquisition process of any portable PA system on the market.



IMPROVE YOUR PRODUCTIVITY

Onboard focal law calculator

The advanced calculator enables inspections on complex specimens like axial or circumferential welds, including different weld profiles. It also supports 2D matrix arrays probes without any additional external software. No inspection job is too difficult.

High performance in acquisition and processing

TOPAZ³²'s 2-GB data file size improves the efficiency of the inspection of large components. Create as many inspection groups as needed with up to 1024 focal laws. Multiple data files can be merged together using the "File Merger" tool. C-Scan data from different files can be consolidated with the "Data Stitching" tool. No inspection job is too large.

16-bit amplitude resolution

Signals can be digitized using an 800% FSH scale reducing the chances of re-scan due to signal saturation during the acquisition. Complete the inspection right the first time.

Improved data acquisition speed

64-bit computing power combined with an onboard SSD (solid-state drive) allow users to perform challenging inspections with large data files without compromising acquisition speed.

Faster analysis

TOPAZ³² capability allows for 2 times faster data processing and analysis compared with previous versions. Regardless of size, data files can be stored for quick access, reducing processing time.

UltraVision® touch software embedded

The embedded advanced focal law calculator with visual feedback allows for easy setup preparation. Onboard volumetric merge and measurement tools enable powerful data analysis and inspection report generation. Leverage one single software platform across the entire family of UT products.

3

ANALYSIS

A full set of basic (cursors, readings) and advanced (merge, C-Scan stitching, gate selectors, volumetric contour, thickness thresholding, etc.) analysis tools are available on-board with fully-configurable display layouts.



4

REPORTING

Ready-to-print custom PDF reports, including hardware settings, scan plan and indication information, are generated in a single touch. Keep paperwork to a bare minimum.



2D matrix arrays

UltraVision Calculator now supports 2D matrix array probes without using any external software. Unlock the power of matrix array probes with TOPAZ³² tools. Complex inspections have never been easier.

Compound scanning

Sectorial and linear scanning combine to increase the covered inspection area while reducing scanning time.

Time reversal support

TOPAZ³² is the first portable instrument to support TIME REVERSAL techniques for inspecting composite materials. Amazing power in a small box**.

Seamless integration

Connect any Zetec scanner or probe to TOPAZ³², and it will automatically recognize and preconfigure accordingly. Probes can be tracked throughout the inspection process, ensuring data integrity and traceability.



Image generated with UltraVision[®] 3 and 3D package

High-Performance Phased Array UT at Your Fingertips

Feature	TOPAZ ^{®32}
Size (H x W x D)	5.2 x 10.3 x 12.8 in (13.2 x 26.0 x 32.6 cm)
Weight	13.9 lb. (6.3 kg)*
Multi-Touch Display	10.4 in. - 1024 x 728 pixels
Air Intake	No
Battery Operation	Yes (hot swap)
Phased Array Connector	ZPAC connector (custom ZIF with latch)
Phased Array Channels	32/128 P or 32/128 PR
UT Channels	2 P/E or 2 P&C
Digitizing Frequency	Up to 100 MHz
Amplitude Resolution	16 bits
Measurement Gates	4 gates + 1 synchronization gate
Data Interfaces	Ethernet 1000 Base-T 1 x USB 3.0 3 x USB 2.0
Maximum PRF	12 kHz
Global Data Throughput	Up to 10 MB/sec
Max. Pulser Voltage (Open Circuit)	105V PA UT / 215V UT
Max. Applied Voltage (50 ohms)	75V PA UT / 200V UT
Bandwidth (-3 dB)	From 0.5 to 18 MHz
Real-time Data Compression	Yes
Rectification	Digital
Filtering	Analog/digital (FIR)
Smoothing (Video Filter)	Digital
Self-Check	Yes
Automated Probe Detection	Yes
Dynamic Depth Focusing (DDF)	Yes
Time Reversal	Yes **
# Focal Laws (DDF)	1024
Maximum Number of Samples	8,192 - 16,384 (remote - UltraVision [®] 3)
Maximum Data File Size	2 GB onboard - 20 GB (remote using UltraVision [®] 3)
Encoder Interfaces	2 quadrature-type
PC Software Control	UltraVision Touch™ embedded
Serves as Protection Key	License for UltraVision Touch™
Data Acquisition & Analysis	UltraVision Touch™ UltraVision [®] 3
Embedded Hard Drive	120 GB SSD
Video Output	DVI (digital and analog)
Instrument Calibration	Compliant with ISO 18563-1

* With one (1) battery

** Time Reversal is not a standard feature in TOPAZ³².

See Ordering Information section for product details.

General Specifications

- Voltage: 100 VAC or 240 VAC
- Frequency: 50 Hz or 60 Hz
- Maximum power: 100 VA
- Operating temperature range: 0°C to 45°C (32°F to 113°F)
- Storage temperature range: -40°C to 70°C (-40°F to 158°F)
- Relative humidity: 80% non-condensing
- CE mark is an attestation of conformity with all applicable directives and standards of the European Community. TOPAZ is an instrument of class 1 and installation category II.

Environmental Tests

- As per MIL-STD-810G:
- Cold storage - 502.5, Procedure I
- Cold operation - 502.5, Procedure II
- Heat storage - 501.4, Procedure I
- Heat operation - 501.4, Procedure II
- Temperature shock - 503.5, Procedure II
- Vibration - 514.6, Procedure I
- Transit drop - 516.6, Procedure IV

Ordering Information

ZPA-IUT-TOPAZ-32/128PR-x64-KIT

Fully integrated portable Phased Array system featuring up to 32 active channels on up to 128 element probes. This instrument can use the same 32 transmitters and receivers or can be operated in PR mode using up to 32 channels as transmitters and 32 other receivers for advanced inspections. Phased Array probes are connected on a solid Zero Insertion Force secured connector, whereas 4 Lemo 00 connectors can be used simultaneously for pulse echo or TOFD inspections.

ZPA-IUT-TOPAZ-32/128P-x64-KIT

Fully integrated portable Phased Array system featuring up to 32 active channels on up to 128 element probes for enhanced inspection capabilities. Phased Array probes are connected on a solid Zero Insertion Force secured connector, whereas 4 Lemo 00 connectors can be used simultaneously for pulse echo or TOFD inspections.

ZPA-IUT-TOPAZ-32/128PR-x64-TR-KIT

Fully integrated portable Phased Array system featuring up to 32 active channels on up to 128 element probes. This instrument can use the same 32 transmitters and receivers or can be operated in PR mode using up to 32 channels as transmitters and 32 other receivers for advanced inspections. Phased Array probes are connected on a solid Zero Insertion Force secured connector, whereas 4 Lemo 00 connectors can be used simultaneously for pulse echo or TOFD inspections. Onboard Time Reversal function capability.

System purchase includes: TOPAZ³² unit with UltraVision Touch™ embedded, 2 batteries, 1 battery charger, 1 carrying case, 1 power cable (North America), 1 power cable (Europe), 1 AC adapter, 1 Ethernet cable and user manual.

A Global Leader in

NDT Solutions



INSTRUMENTS

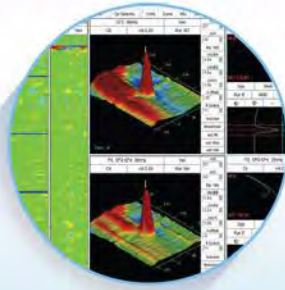

SOFTWARE



PROBES & WEDGES



MECHANICAL SYSTEMS



FOR MORE INFORMATION ABOUT TOPAZ OR OTHER ZETEC PRODUCTS
CONTACT US AT info@zetec.com OR VISIT www.zetec.com.



Zetec holds ISO 9001
and ISO/IEC 17025
certifications



NDT PAINTBRUSH, BY ZETEC. AN EVOLUTION IN THE FIELD OF INSPECTION SOLUTIONS FOR THE DETECTION OF WALL-THICKNESS REDUCTIONS DUE TO CORROSION, ABRASION OR EROSION. THANKS TO NDT PAINTBRUSH, YOU CAN MAKE THE RIGHT DECISIONS AND LEAVE UNCERTAINTY BEHIND.

LEAVING UNCERTAINTY BEHIND



FOR MORE INFORMATION, VISIT zetec.com

ZETEC
THE INSPECTION ADVANTAGE



Printed in Canada 10050346-EN-1 propageo.com

CORROSION

LEAVING UNCERTAINTY BEHIND



AGILITY

Optimum ergonomics,
best-in-class maneuverability

AGILE ON PLATES



Real-time onboard TOPAZ data position calculation allows moving freely on any 2D surface without any external mechanical constraint. Thanks to its magnetic, side-by-side wheels, NDT PaintBrush solution is a stable instrument that will stick firmly and that easily adapts to any magnetic surface. When using composite dedicated wheels, NDT PaintBrush becomes the ideal solution for the inspection of non-magnetic surfaces.

AGILE ON PIPES



NDT PaintBrush's size and ergonomics make it the perfect pipe inspection tool. The device can inspect on curved surfaces and on pipes having a diameter as small as 4 inches. UltraVision™ analysis tools complete the solution allowing for data analysis and evaluation either online during inspection or as post-processing data analysis.

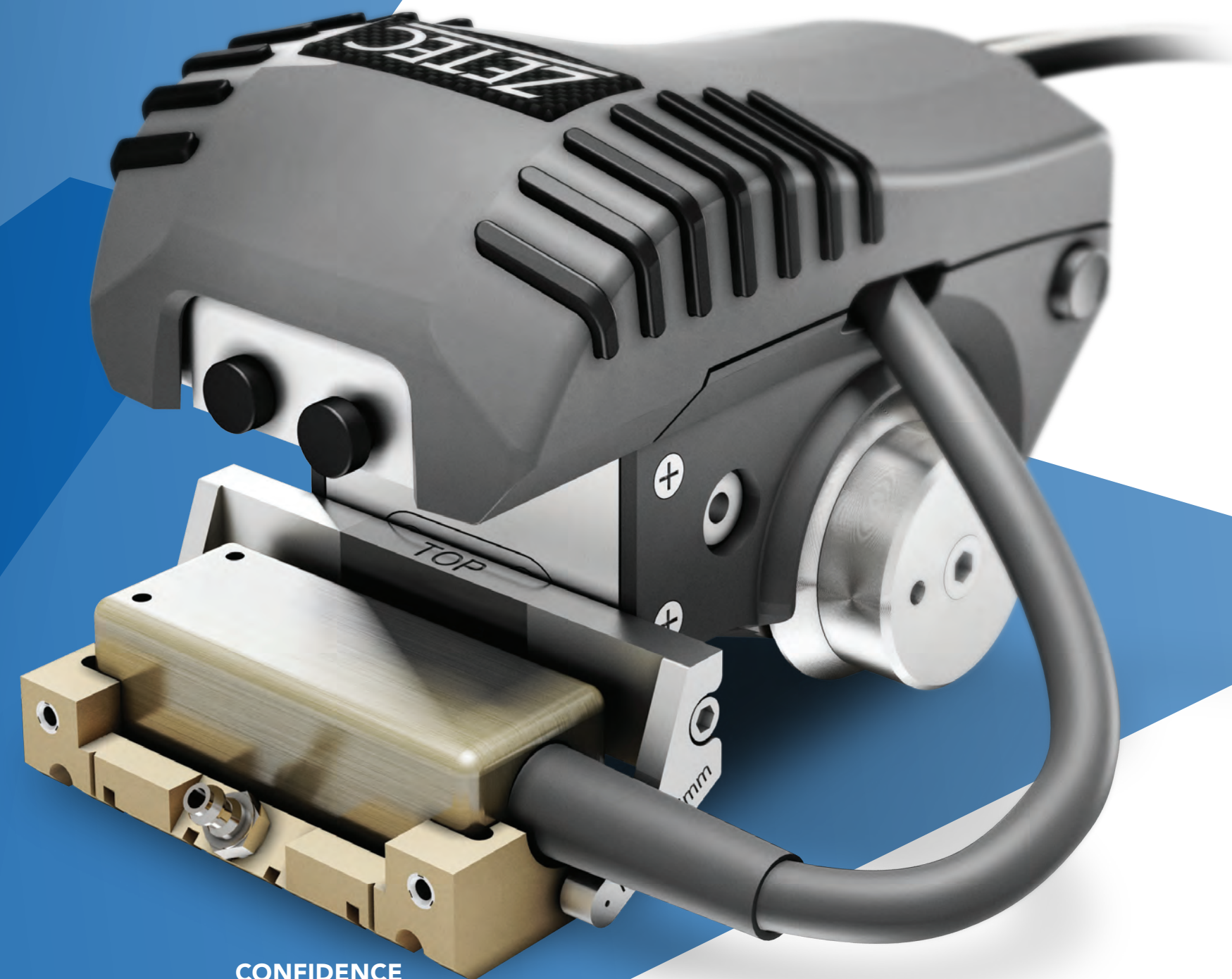

CONFIDENCE

The surface to be inspected
will be 100% inspected, each time

SEE THE LOCATION, SEE THE ORIENTATION

Seeing the location of the probe and data in real time during inspection ensures that the inspection process is performed well covering all the target area. Seeing the indications in real time allows you to properly assess the inspection process.

OPTIMUM POD: FIND CORROSION PITTINGS

Detects small wall-thickness losses comparable to 1.6 mm (0.06 in.) round bottom holes with coverage from 2 mm (0.07 in.) up to 25 mm (1 in.), giving a higher detection probability.

NEVER MISS AN AREA

NDT PaintBrush is easy to use and requires minimum training while incorporating advanced high-performance technology. Don't miss anything and rest assured that the inspection is properly performed.

CLARITY

With TOPAZ, collected
data is easily understood



IMAGING OF SCANNED AREA

The device makes it easy to monitor the state and evolution of the inspected part. Get imaging of scanned area as well as its stitching capability.

EXPORT TO EXCEL

Easy exporting to Excel equals gain in productivity. You can export data to CSV files for extended compatibility with external software.

EXTENSIVE STATISTICAL DATA

NDT PaintBrush solution provides valuable onboard statistics that are easy to understand and analyze.

3D PLOTING

Corrosion is easily identifiable with UltraVision 3D—get 3D plotting for outstanding rendering of corrosion data on specimen parts. The tool can specify the depth of the corrosion. Therefore you know when action must be taken.

REQUIRES ULTRAVISION 3D LICENSE ON AN EXTERNAL COMPUTER



Time Reversal—Simplifying Inspections

Inspections are becoming more complex

The aerospace industry is constantly evolving to produce aircraft that are lighter to recognize fuel saving efficiencies. Composite materials (e.g., CFRP) offer an excellent weight to robustness ratio and are increasingly being incorporated into aircraft structures. Composite aircraft parts typically have complex and variable geometries requiring ultrasonic inspection systems to have intricate and expensive mechanical surface following scanners.

Currently, rapid and reliable phased array ultrasound (PAUT) inspection requires a combination of dedicated phased array probe configurations, high-performance

PAUT electronics, multi-axis scanners and advanced software algorithms.

Time Reversal allows for quick and precise PAUT inspections on complex and variable CFRP geometries.

Simplify the inspection

Time Reversal is a real-time adaptive phased array ultrasound technique based on measurement of front wall surface echoes and TOF (time of flight) compensation of returned ultrasound data. Composite material manufacturers can now dynamically adjust for part misalignment, water column variations, and surface geometry changes. This can deliver improved cost and time efficiencies on the production floor.



www.zetec.com

Improving signal quality, every time

Applying Time Reversal, misalignments between probe and part surface are easily compensated, resulting in improved ultrasound signal quality.

Time Reversal and traditional PAUT inspection configurations deliver comparable results when the ultrasound probe and part are well aligned.

In the case of probe to part misalignment, Time Reversal extends the inspection limits way beyond those seen with a traditional PAUT configuration.

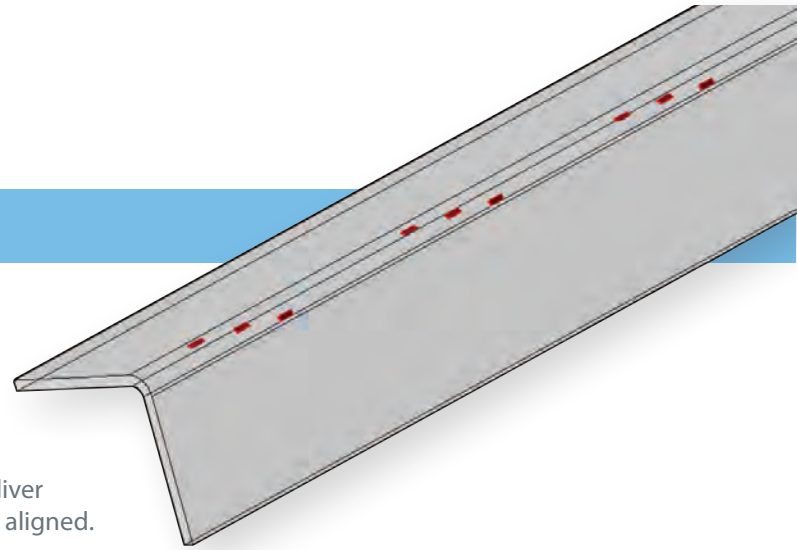

ALIGNED

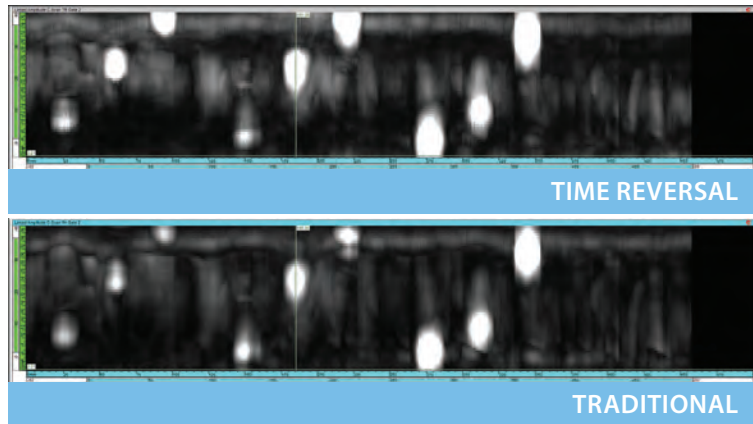

TIME REVERSAL

TRADITIONAL



MISALIGNED

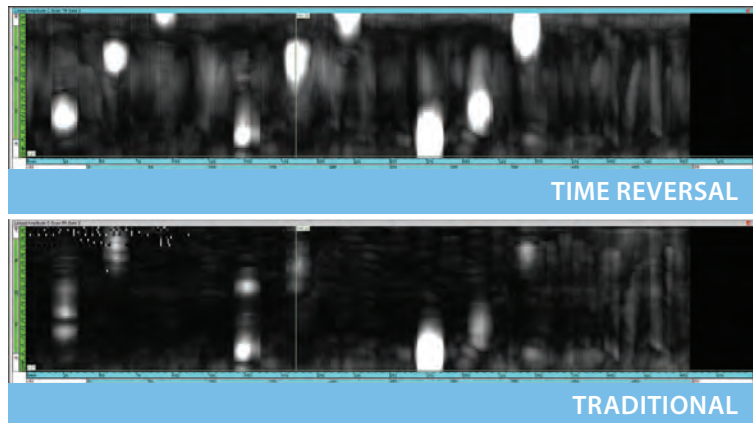

TIME REVERSAL

TRADITIONAL



Zetec holds ISO 9001 and ISO/IEC 17025 certifications



For more information on Time Reversal, visit: www.zetec.com

© Zetec, Inc. 2015. Rev 12/15. All rights reserved.
All the information herein is subject to change without prior notification. 10052725

www.zetec.com



PHASED ARRAY UT PROBES AND WEDGES

Product Catalog



*Standardized Designs
and Advanced Technology*

www.zetec.com

About ZETEC

ZETEC, founded in 1968, is the leading provider of nondestructive evaluation (NDE) inspection solutions based on integrated multi-method technologies - eddy current, ultrasonic (UT), phased array UT, remote field, and magnetic flux leakage. The company portfolio includes a complete line of systems, instrumentation, software products, supplies, calibration, repair, training, and inspection services, all offered worldwide. ZETEC, a trusted partner in mission critical inspection applications, is headquartered in Snoqualmie, Washington with offices in Quebec City, Quebec, Canada; Seoul, Korea; Beijing, China; and Paris, France.

ZETEC's innovative approach has completely redefined the potential of phased array UT technology by enabling highly efficient and more flexible inspection solutions. With a wealth of high-quality phased array UT instruments, ZETEC offers a complete line of standard phased array UT probes and wedges in order to get the most out of your system.

ZETEC has the expertise and engineering skills to support you for any challenging inspections with dedicated custom designs for your phased array UT probes and wedges.

For more information about ZETEC's products and services:
visit www.zetec.com or contact us at info@zetec.com

Table of Contents

INTRODUCTION TO PHASED ARRAY UT.....	iv
PHYSICAL PRINCIPLES.....	iv
PA PROBE CONFIGURATIONS.....	iv
BENEFITS OF BEAM SIMULATION.....	v
STANDARD PHASED ARRAY PROBES AND WEDGES.....	vi
CUSTOM PHASED ARRAY PROBES AND WEDGES.....	vii
GLOSSARY.....	viii
NOMENCLATURE.....	x
PROBES FOR AZIMUTHAL SCANNING.....	1
AS-5MHZ.....	2
AS-7.5MHZ.....	4
AS-10MHZ.....	6
AM-2.25MHZ.....	8
AM-3.5MHZ.....	10
AM-5MHZ.....	12
AM-10MHZ.....	14
AL-3.5MHZ.....	16
AL-5MHZ.....	18
AXL-1.5MHZ.....	20
AXL-2.25MHZ.....	22
PROBES FOR LINEAR SCANNING.....	25
LM-2.25MHZ.....	26
LM-3.5MHZ.....	30
LM-5MHZ.....	34
LM-10MHZ.....	38
LL-2.25MHZ.....	42
LL-3.55MHZ.....	46
LL-5MHZ.....	50
LL-10MHZ.....	54
WEDGES FOR AZIMUTHAL SCANNING.....	58
WEDGES FOR LINEAR SCANNING.....	60
ADAPTERS, SPLITTERS AND OTHER ACCESSORIES.....	62

Introduction to Phased Array UT

Phased array (PA) technology allows to control the acoustic characteristics (refracted angle, focal distance, aperture, etc.) of ultrasonic beams through software. Compared to conventional ultrasonic testing (UT) methods, this opens a series of new possibilities:

- Multiple refracted angles and focal distances can be generated simultaneously by a single search unit;
- Ultrasonic beams can be electronically moved over the length of the PA probe, without any mechanical movement;
- By using multiple ultrasonic beams, the probability of detection can be increased;
- Automated or semi-automated inspection methods can be implemented more efficiently.

ZETEC offers a complete line of inspection systems and probes which allow you to fully exploit the capabilities of PA UT and help you perform more efficient and reliable inspections.

PHYSICAL PRINCIPLES

A phased array probe consists of a series of piezo-composite elements, which can be excited independently one from the others. By precisely controlling the time delays between the excitation of the individual elements, ultrasonic beams of various angles, focal distances and aperture can be transmitted in the inspected specimen. The returning echo from a reflector is detected by each elements of the PA probe at a slightly different time. The individual echo signals are then time-shifted before being summed up. The result of this process is an A-scan that emphasizes the response from the desired focal point.

Beam Emission

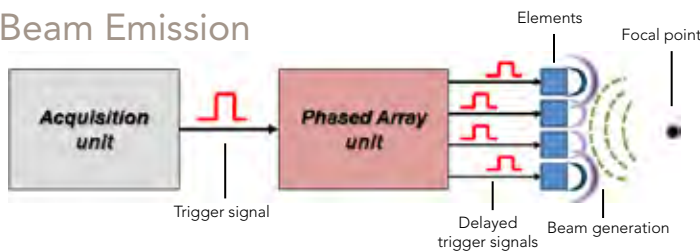

Signal Reception

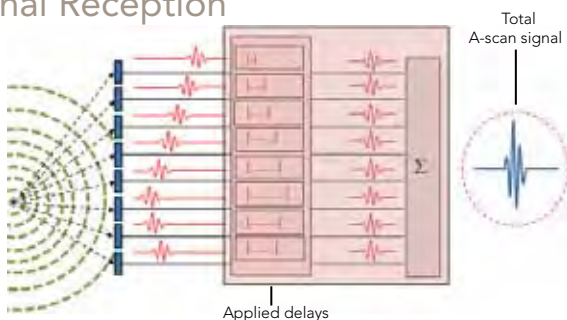

PA PROBE CONFIGURATIONS

ZETEC's standard probes are offered in two main configurations:

- **Azimuthal:** Probes that are optimized to produce multiple refracted beam angles

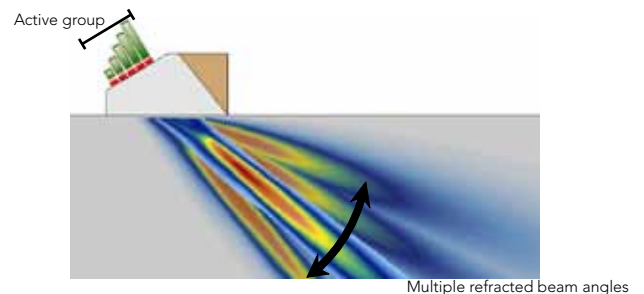

- **Linear:** Long transducers that are optimized for electronically moving the active aperture along the probe

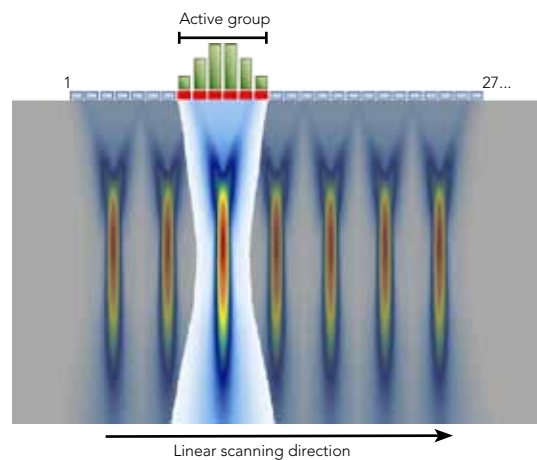

BENEFIT OF BEAM SIMULATION

Acoustic beam simulation allows you to compute, visualize and characterize the energy distribution of the acoustic beam generated by your phased array probe.

The UltraVision® software offers all the tools to validate your acoustic beam characteristics for inspection of both simple specimens and more complex surfaces.

In order to make it easy for you to select the phased array probe(s) that you need for your specific inspections, this catalog shows acoustic beam simulations of typical LW and SW configurations with each of our standard phased array probes, in the case of natural focusing conditions, and relevant quantitative information about the acoustic field is provided.

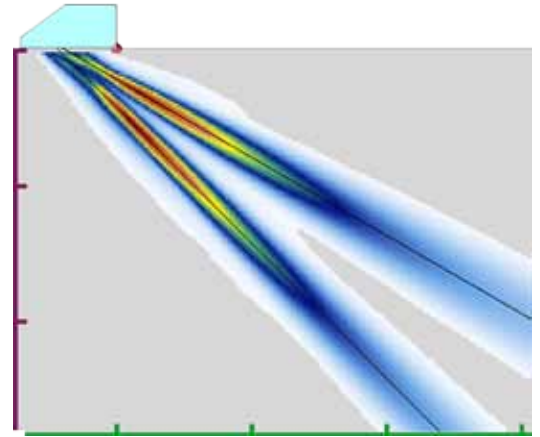

Standard Phased Array Probes and Wedges

PROBES

ZETEC's standard phased array UT probes are offered in 6 different sizes. Special care was put in their design in order to provide you with an ergonomic casing with captive screws for easy fixation on wedges or scanning mechanism.

The frequencies of the standard probes range from 1.5 to 10 MHz, covering a wide spectrum of applications: inspection of thin welded parts, inspection of thick stainless steel specimens, efficient corrosion mapping for large inspection surfaces, etc.

When used with ZETEC's ZIRCON™ 32/128PR PA equipment and the UltraVision® software, you can take advantage of the auto probe recognition in order to quickly and easily upload all your essential probe parameters thus simplifying your setup creation process.

All probes come with a standard 5-meter (16.4-foot) cable and can be equipped with various types of connectors. A series of connector adaptors and splitters are also available to allow the operation of the probes on multiple equipments.

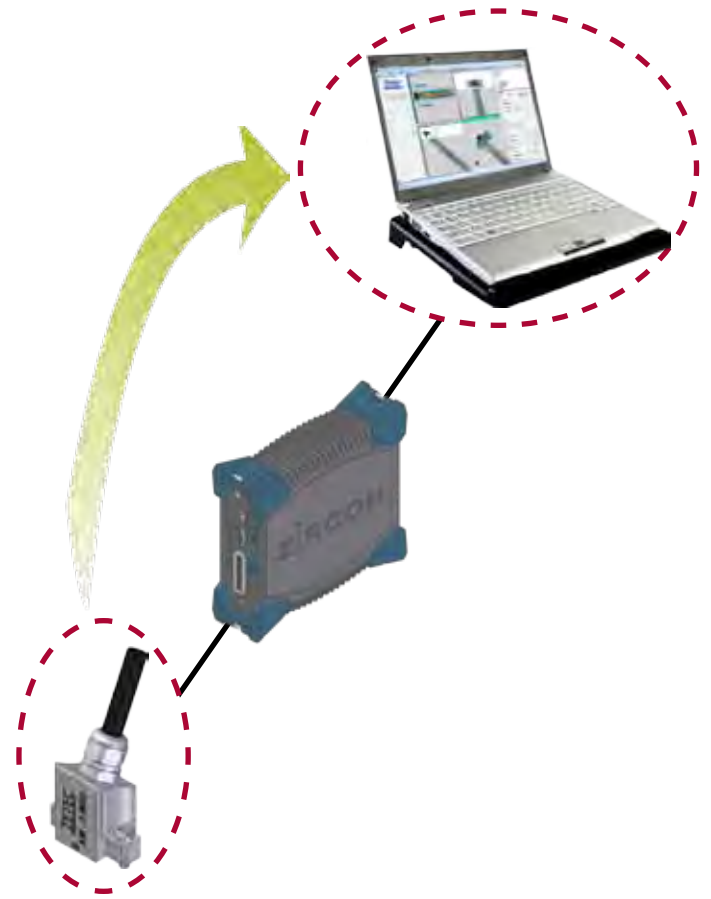

Irrigation

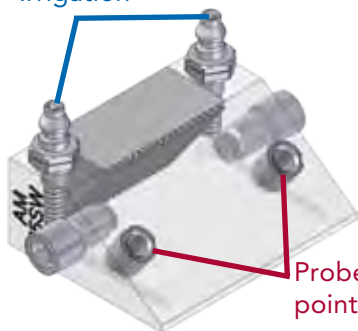

Probe Fixation points

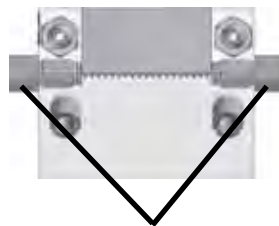

Wedge Grip Points

WEDGES

ZETEC also offers a complete line of wedges to complement its phased array UT probes. Designed to tackle a number of applications, the wedges come equipped with irrigation and easy fixation points for easy interface with a scanning mechanism.

Although all wedges listed here are designed for flat specimens, you can ask for custom contouring of the contact surface for cylinder shape parts.

Custom Phased Array Probes and Wedges

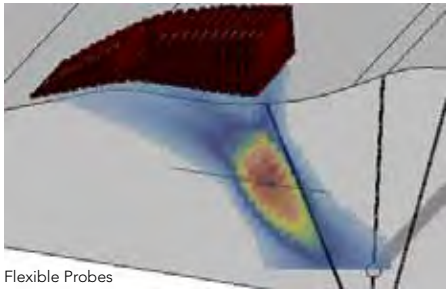

Flexible Probes

In addition to the standard probe models, Zetec can provide you with engineering services for design and manufacturing of custom phased array probes and wedges or minor modifications to standard probes and wedges.

ZETEC has the expertise and experience to assist you in determining the most appropriate transducers and wedges for your inspection.

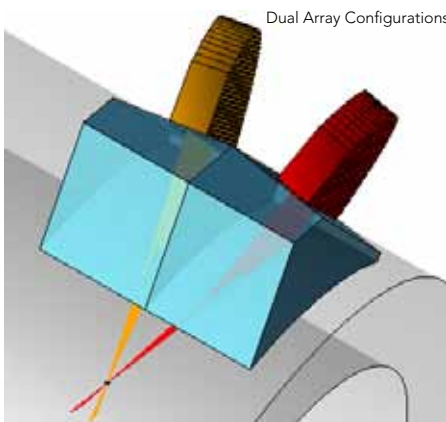

Dual Array Configurations

Regardless of the application, ZETEC is able to provide you the probes and wedges you need:

- 1D Linear and 2D Matrix arrays
- Dual configuration of 1D Linear and 2D Matrix arrays
- Low-frequency probes
- Dedicated contour wedges
- And much more...

2D Matrix Arrays



Glossary

The following definitions contain all the essential information necessary to understand the different parameters of phased array probes and wedges.

- **Frequency**
Theoretical central frequency of the ultrasonic pulse generated by your probe
- **Primary Axis**
Axis along which the individual elements are aligned for 1D linear probe
- **Secondary Axis**
Axis perpendicular to the primary axis of a probe
- **Number of Elements (Primary Axis)**
Total number of elements aligned along the primary axis
- **Number of Elements (Secondary Axis)**
Total number of elements aligned along the secondary axis (2D Matrix Array only)
- **Primary Axis Pitch**
Center-to-center distance between two consecutive elements along the primary axis
- **Secondary Axis Pitch**
Center-to-center distance between two consecutive elements along the secondary axis (2D Matrix Array only)
- **Primary Axis Aperture**
Dimension of the probe surface along the primary axis
- **Secondary Axis Aperture**
Dimension of the probe surface along the secondary axis

1D Linear Array

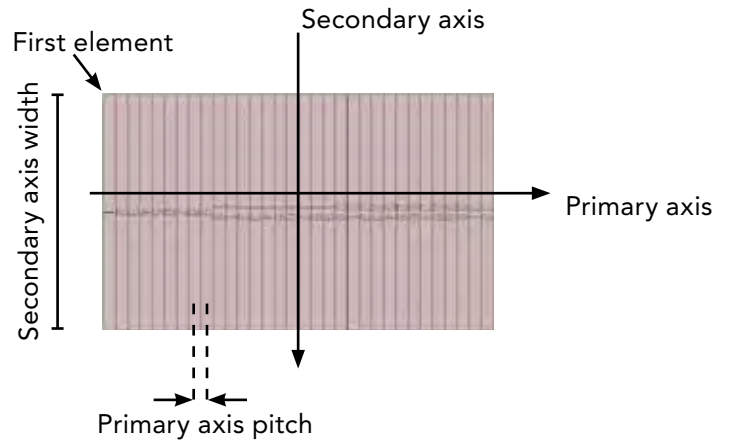

2D Matrix Array

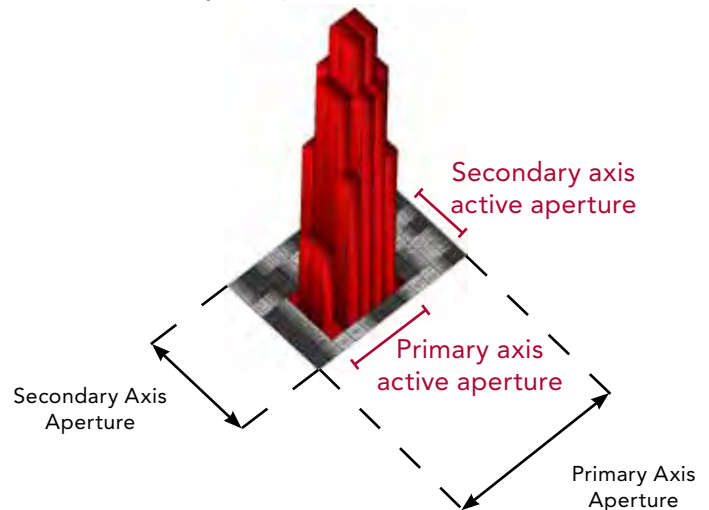
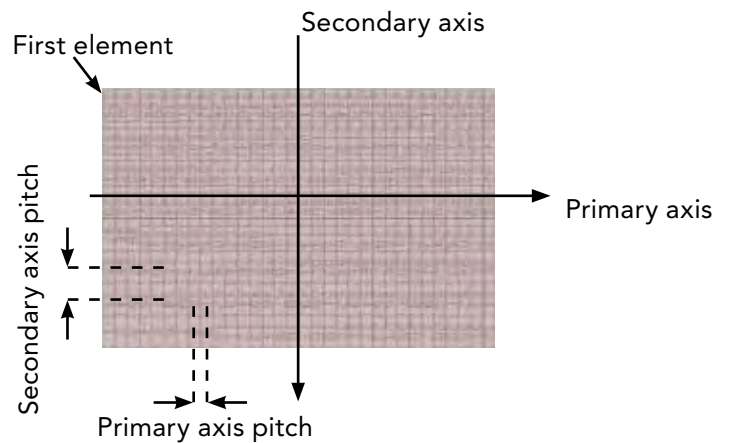

- **Active Aperture**
Group of elements effectively used for the generation and reception of an ultrasonic beam

- **Near Field Length**
Distance along the beam axis from the probe surface to the position where the maximum sound field intensity is reached

- **Maximum Sound Field Depth**
Depth at which the maximum sound field intensity on the beam axis is reached

- **Focal Zone Length**
Distance along the beam axis between the positions before and beyond the focal point (maximum intensity) where the sound field intensity is reduced by 6 dB

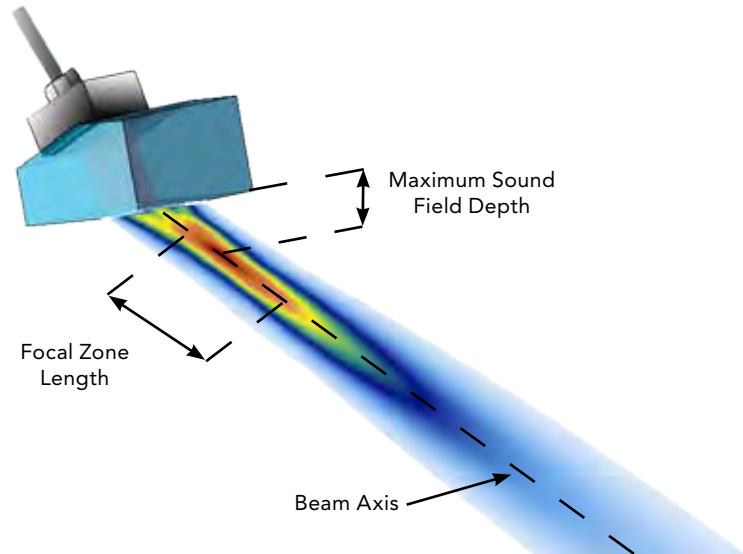

- **Wedge Angle**
Angle between the primary axis of the probe and the flat projection of the specimen surface along the mechanical axis (scan or index)

- **Height at the Middle of the First Element (H1)**
Height of the first element of the probe when placed on a wedge

- **Primary Axis Offset at the Middle of the First Element (X1)**
Position along the primary axis of the first element of the probe from the wedge reference

- **Secondary Axis Offset at the Middle of the First Element (Y1)**
Position along the secondary axis of the first element of the probe from the wedge reference

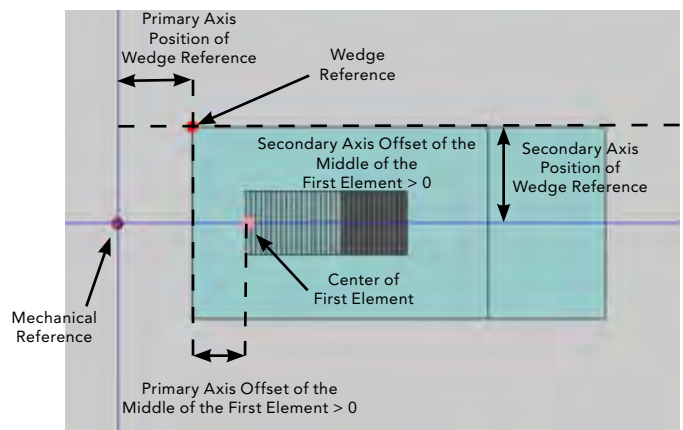
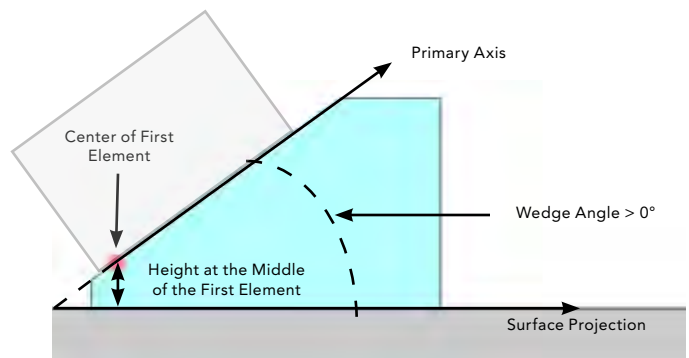

Nomenclature

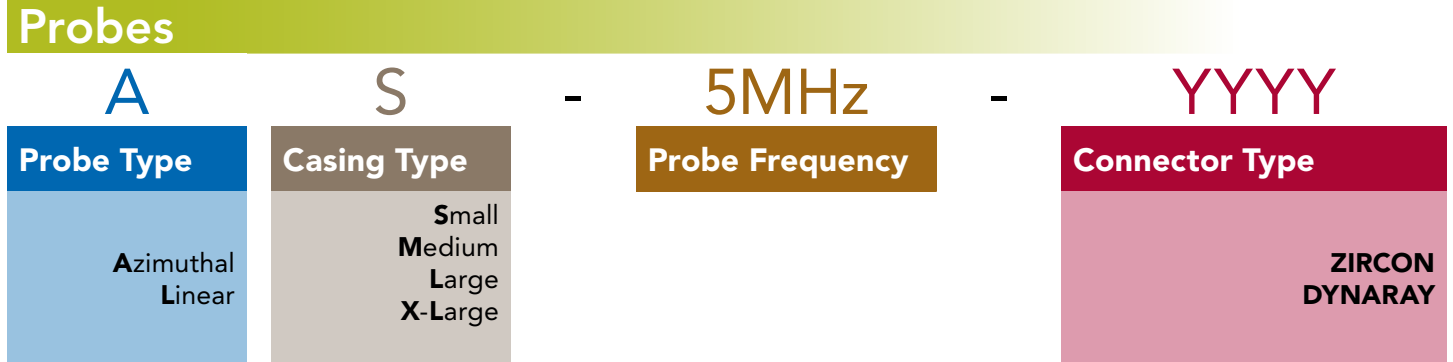

Probe Type	Casing Type	Frequency (MHz)	Number of Elements	Page
Type A	Small	5.0	12	2
		7.5	12	4
		10.0	16	6
Type A	Medium	2.25	16	8
		3.5	16	10
		5.0	16	12
		10.0	32	14
Type A	Large	3.5	32	16
		5.0	32	18
Type A	X-Large	1.5	32	20
		2.25	32	22
Type L	Medium	2.25	64	26
		3.5	64	30
		5.0	64	34
		10.0	64	38
Type L	Large	2.25	128	42
		3.5	128	46
		5.0	128	50
		10.0	128	54

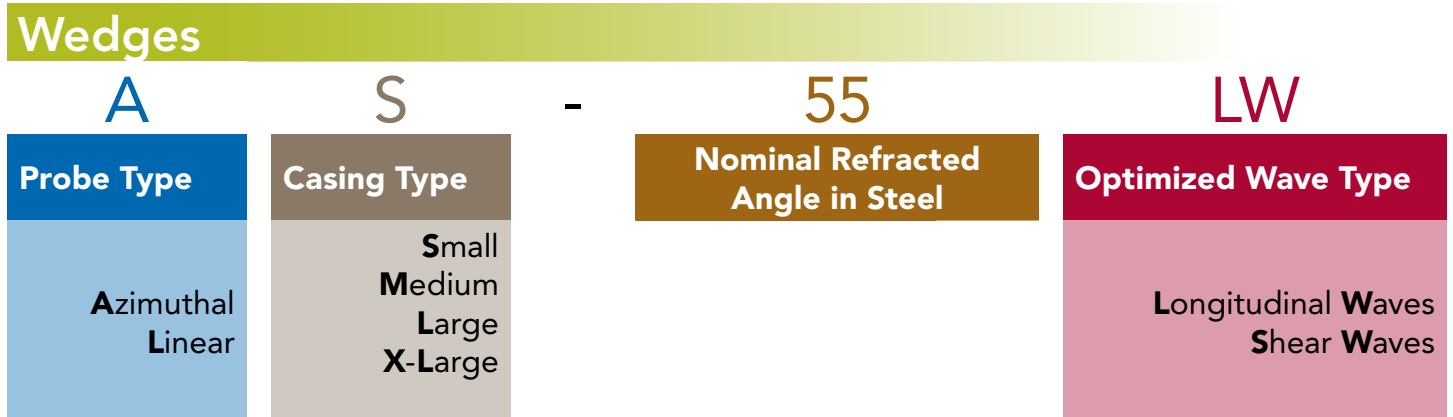

Probes for Azimuthal Scanning



Type A - Small - 5 MHz



Features & Benefits

- Small footprint
- Optimized for thin welded parts
- Wave layers with acoustic adaptation to Rexolite®
- Probe cable length: 5 m (16 ft.)
- Two connector types available: ZIRCON and DYNARAY compatible

Probe Specifications and Dimensions

Part ID	Frequency (MHz)	Number of elements	Primary axis Pitch	Primary axis aperture	Secondary axis aperture	External dimensions		
						L	W	H
AS-5MHz-*	5.0	12	0.6 mm (0.024 in.)	7.2 mm (0.283 in.)	7.2 mm (0.283 in.)	11.0 mm (0.433 in.)	30.0 mm (1.181 in.)	25.0 mm (0.984 in.)

(*) : -ZIRCON or -DYNARAY



Type A - Small / 55SW

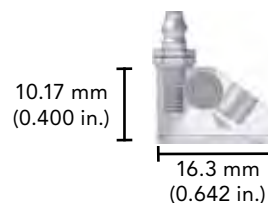
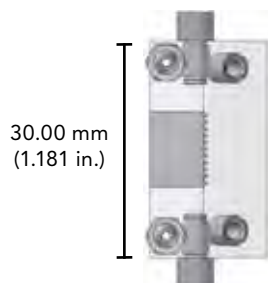

Type A - Small / 55LW

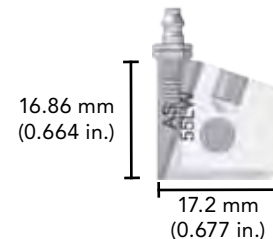
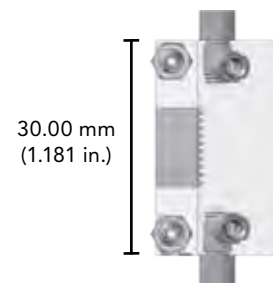

Recommended Wedges

Part ID	Wave type	Name	Nominal angle in steel	Optimized refracted beam angle range (in steel)
AS-55LW	LW	Type A - Small / 55LW	55°	30° to 70°
AS-55SW	SW	Type A - Small / 55SW	55°	40° to 70°

Acoustic Beam Simulation

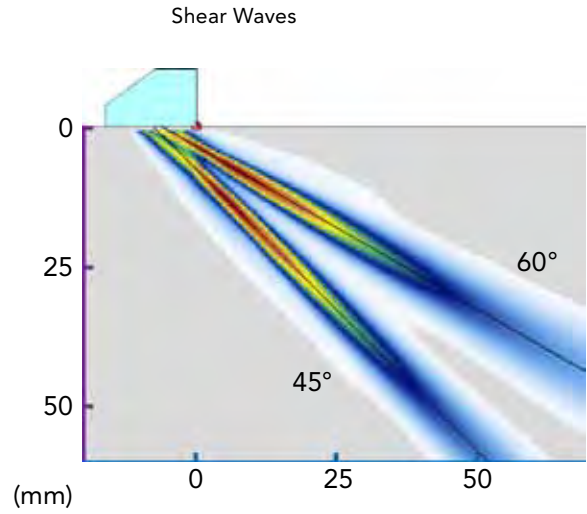
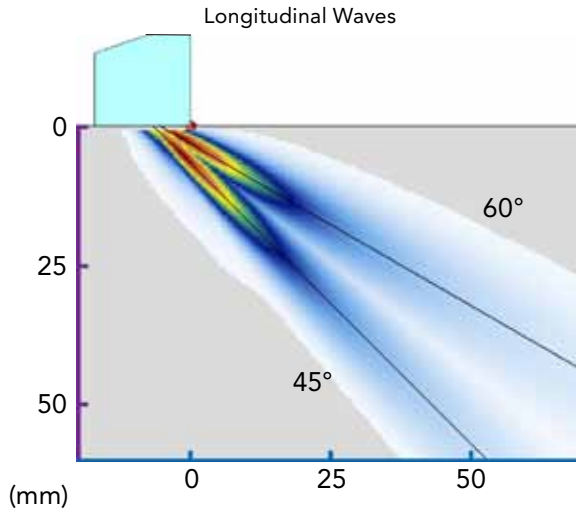

Acoustic Beam Characteristics (from Simulation Data)

Considered Active Aperture	12 elements (1 to 12)			
	45°		60°	
Angle				
Wave Type	LW	SW	LW	SW
Maximum Sound Field Depth	5.00 mm (0.197 in.)	12.00 mm (0.472 in.)	2.00 mm (0.079 in.)	7.00 mm (0.275 in.)
Focal Zone Length	20.49 mm (0.807 in.)	44.55 mm (1.754 in.)	16.10 mm (0.634 in.)	40.92 mm (1.611 in.)
Dimension in the Incident Plane	2.40 mm (0.094 in.)	2.45 mm (0.085 in.)	2.64 mm (0.096 in.)	2.77 mm (0.109 in.)
Dimension in the Perpendicular Plane	4.00 mm (0.157 in.)	4.00 mm (0.157 in.)	4.00 mm (0.157 in.)	4.00 mm (0.157 in.)

Type A - Small - 7.5 MHz

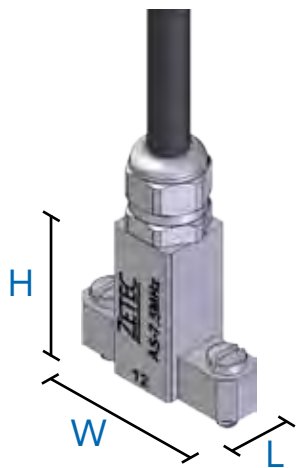

Features & Benefits

- Small footprint
- Optimized for thin welded parts
- Wave layers with acoustic adaptation to Rexolite®
- Probe cable length: 5 m (16 ft.)
- Two connector types available: ZIRCON and DYNARAY compatible

Probe Specifications and Dimensions

Part ID	Frequency (MHz)	Number of elements	Primary axis Pitch	Primary axis aperture	Secondary axis aperture	External dimensions		
						L	W	H
AS-7.5MHz-*	7.5	12	0.6 mm (0.024 in.)	7.2 mm (0.283 in.)	7.2 mm (0.283 in.)	11.0 mm (0.433 in.)	30.0 mm (1.181 in.)	25.0 mm (0.984 in.)

(*) : -ZIRCON or -DYNARAY



Type A - Small / 55SW

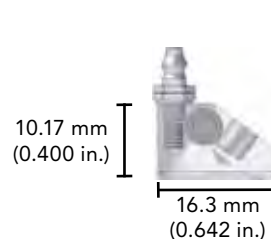
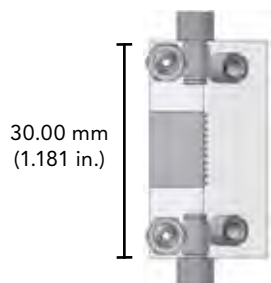

Type A - Small / 55LW

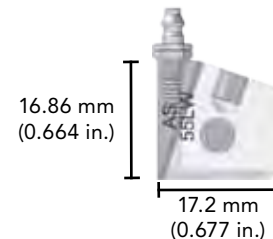
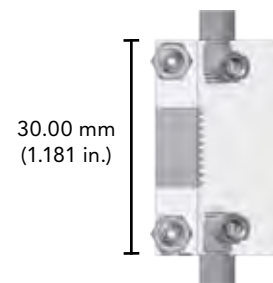

Recommended Wedges

Part ID	Wave type	Name	Nominal angle in steel	Optimized refracted beam angle range (in steel)
AS-55LW	LW	Type A - Small / 55LW	55°	30° to 70°
AS-55SW	SW	Type A - Small / 55SW	55°	40° to 70°

Acoustic Beam Simulation

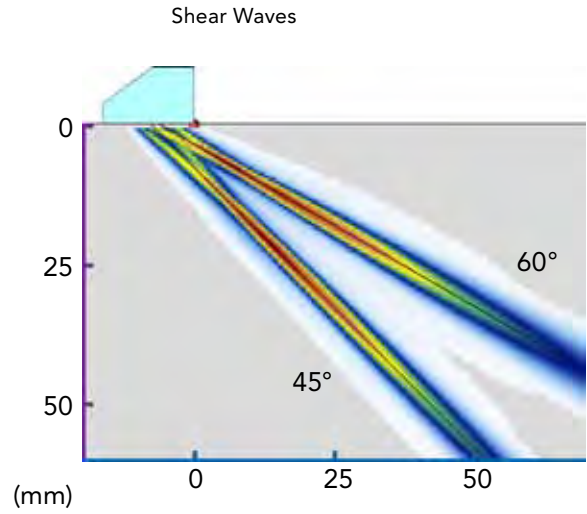
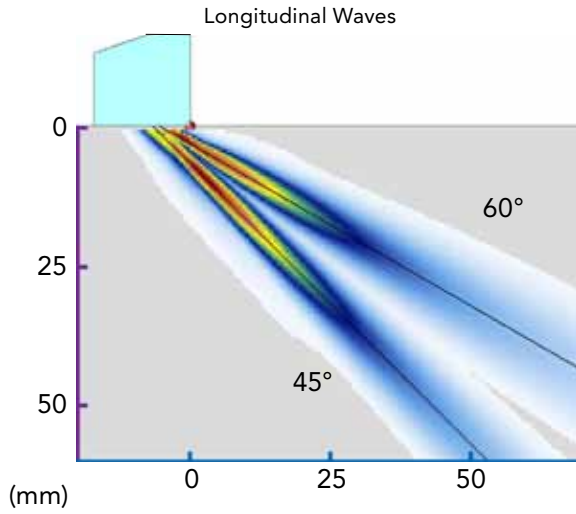

Acoustic Beam Characteristics (from Simulation Data)

Considered Active Aperture	12 elements (1 to 12)			
	45°		60°	
Angle				
Wave Type	LW	SW	LW	SW
Maximum Sound Field Depth	10.00 mm (0.394 in.)	20.00 mm (0.787 in.)	2.00 mm (0.079 in.)	7.00 mm (0.275 in.)
Focal Zone Length	33.94 mm (1.336 in.)	64.35 mm (2.533 in.)	25.72 mm (1.013 in.)	58.85 mm (2.317 in.)
Dimension in the Incident Plane	2.27 mm (0.089 in.)	2.40 mm (0.094 in.)	2.50 mm (0.098 in.)	2.66 mm (0.105 in.)
Dimension in the Perpendicular Plane	4.00 mm (0.157 in.)	4.00 mm (0.157 in.)	5.00 mm (0.197 in.)	5.00 mm (0.197 in.)

Type A - Small - 10 MHz

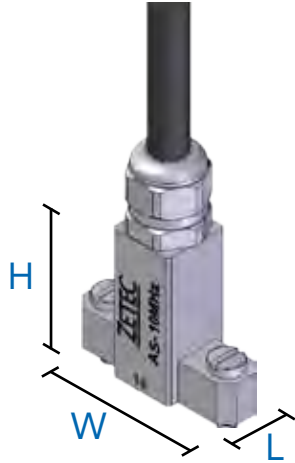

Features & Benefits

- Small footprint
- Optimized for thin welded parts
- Wave layers with acoustic adaptation to Rexolite®
- Probe cable length: 5 m (16 ft.)
- Two connector types available: ZIRCON and DYNARAY compatible

Probe Specifications and Dimensions

Part ID	Frequency (MHz)	Number of elements	Primary axis Pitch	Primary axis aperture	Secondary axis aperture	External dimensions		
						L	W	H
AS-10MHz-*	10.0	16	0.31 mm (0.012 in.)	4.96 mm (0.195 in.)	5.00 mm (0.197 in.)	11.0 mm (0.433 in.)	30.0 mm (1.181 in.)	25.0 mm (0.984 in.)

(*) : -ZIRCON or -DYNARAY



Type A - Small / 55SW

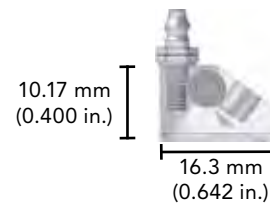
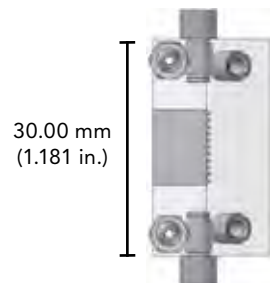

Type A - Small / 55LW

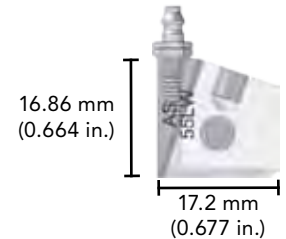
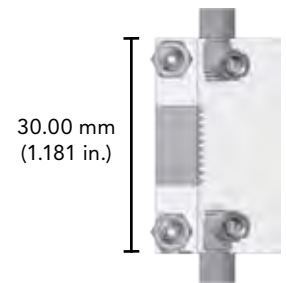

Recommended Wedges

Part ID	Wave type	Name	Nominal angle in steel	Optimized refracted beam angle range (in steel)
AS-55LW	LW	Type A - Small / 55LW	55°	30° to 70°
AS-55SW	SW	Type A - Small / 55SW	55°	40° to 70°

Acoustic Beam Simulation

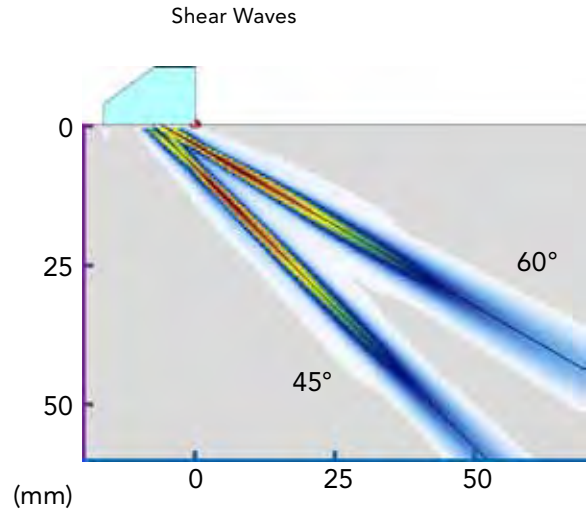
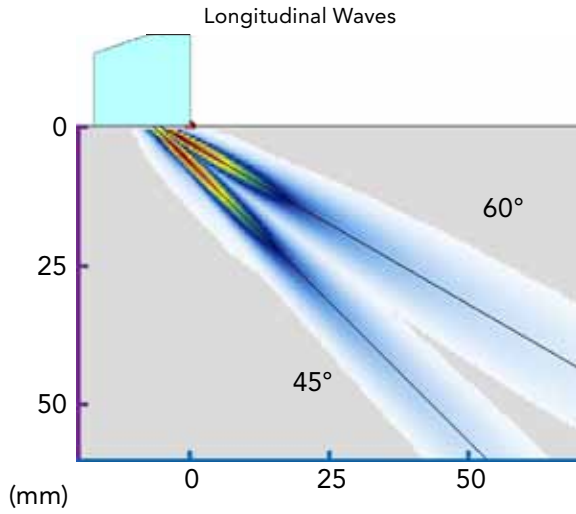

Acoustic Beam Characteristics (from Simulation Data)

Considered Active Aperture	16 elements (1 to 16)			
	45°		60°	
Angle				
Wave Type	LW	SW	LW	SW
Maximum Sound Field Depth	4.50 mm (0.177 in.)	11.00 mm (0.433 in.)	2.00 mm (0.079 in.)	6.50 mm (0.256 in.)
Focal Zone Length	18.73 mm (0.737 in.)	42.07 mm (1.656 in.)	14.31 mm (0.563 in.)	38.26 mm (1.506 in.)
Dimension in the Incident Plane	1.55 mm (0.061 in.)	1.87 mm (0.074 in.)	1.84 mm (0.072 in.)	1.91 mm (0.075 in.)
Dimension in the Perpendicular Plane	2.00 mm (0.079 in.)	2.00 mm (0.079 in.)	3.00 mm (0.118 in.)	3.00 mm (0.118 in.)

Type A - Medium - 2.25 MHz



Features & Benefits

- Small footprint
- Wide range of applications
- Wave layers with acoustic adaptation to Rexolite®
- Probe cable length: 5 m (16 ft.)
- Two connector types available: ZIRCON and DYNARAY compatible

Probe Specifications and Dimensions

Part ID	Frequency (MHz)	Number of elements (Primary axis)	Primary axis Pitch (mm)	Primary axis aperture	Secondary axis aperture	External dimensions		
						L	W	H
AM-2.25MHz-*	2.25	16	0.75 mm (0.030 in.)	12.00 mm (0.472 in.)	12.00 mm (0.472 in.)	16.0 mm (0.630 in.)	30.0 mm (1.181 in.)	25.0 mm (0.984 in.)

(*) : -ZIRCON or -DYNARAY

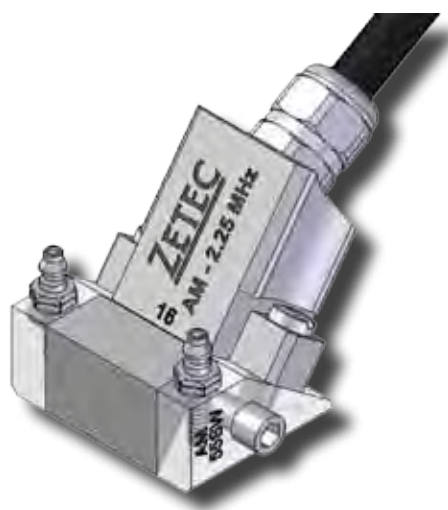

Type A - Medium / 55SW

Type A - Medium / 55LW

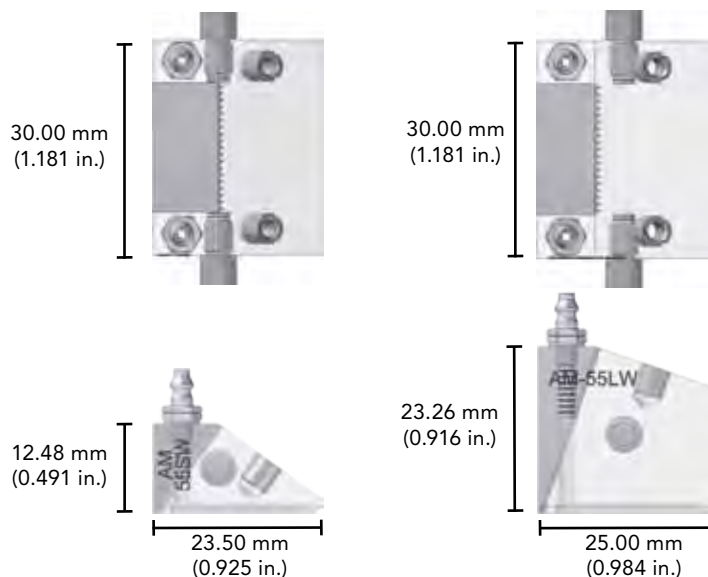

Recommended Wedges

Part ID	Wave type	Name	Nominal angle in steel	Optimized refracted beam angle range (in steel)
AM-55LW	LW	Type A - Medium / 55LW	55°	30° to 70°
AM-55SW	SW	Type A - Medium / 55SW	55°	40° to 70°

Acoustic Beam Simulation

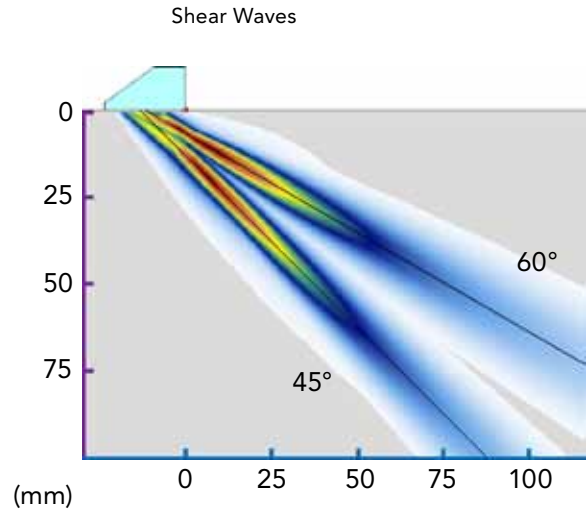
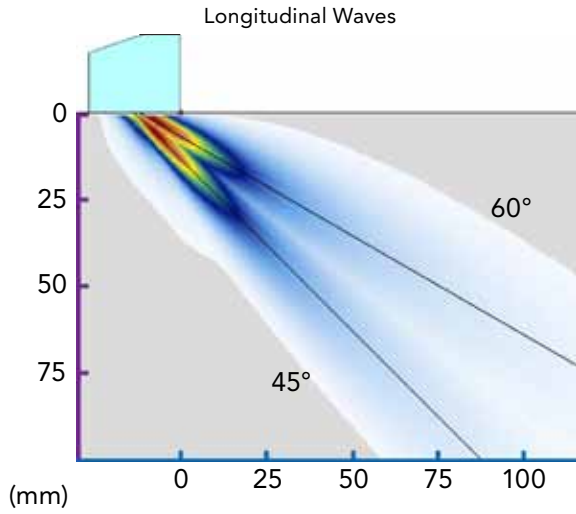

Acoustic Beam Characteristics (from Simulation Data)

Considered Active Aperture	16 elements (1 to 16)			
	45°		60°	
Angle				
Wave Type	LW	SW	LW	SW
Maximum Sound Field Depth	5.50 mm (0.217 in.)	20.00 mm (0.787 in.)	2.00 mm (0.079 in.)	11.00 mm (0.433 in.)
Focal Zone Length	26.47 mm (1.042 in.)	61.53 mm (2.422 in.)	20.90 mm (0.823 in.)	56.53 mm (2.226 in.)
Dimension in the Incident Plane	4.45 mm (0.175 in.)	4.50 mm (0.177 in.)	4.44 mm (0.175 in.)	4.90 mm (0.193 in.)
Dimension in the Perpendicular Plane	7.00 mm (0.276 in.)	6.00 mm (0.236 in.)	8.00 mm (0.315 in.)	8.00 mm (0.315 in.)

Type A - Medium - 3.5 MHz



Features & Benefits

- Small footprint
- Wide range of applications
- Wave layers with acoustic adaptation to Rexolite®
- Probe cable length: 5 m (16 ft.)
- Two connector types available: ZIRCON and DYNARAY compatible

Probe Specifications and Dimensions

Part ID	Frequency (MHz)	Number of elements	Primary axis Pitch	Primary axis aperture	Secondary axis aperture	External dimensions		
						L	W	H
AM-3.5MHz-*	3.5	16	0.60 mm (0.024 in.)	9.60 mm (0.378 in.)	10.00 mm (0.374 in.)	16.0 mm (0.630 in.)	30.0 mm (1.181 in.)	25.0 mm (0.984 in.)

(*) : -ZIRCON or -DYNARAY



Type A - Medium / 55SW

Type A - Medium / 55LW

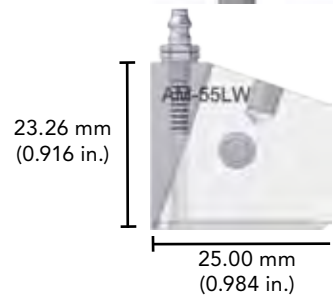
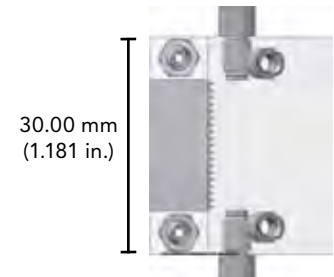
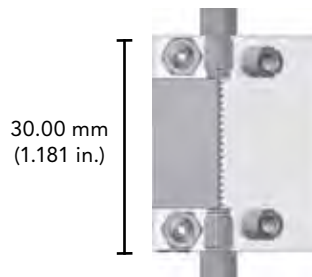

Recommended Wedges

Part ID	Wave type	Name	Nominal angle in steel	Optimized refracted beam angle range (in steel)
AM-55LW	LW	Type A - Medium / 55LW	55°	30° to 70°
AM-55SW	SW	Type A - Medium / 55SW	55°	40° to 70°

Acoustic Beam Simulation

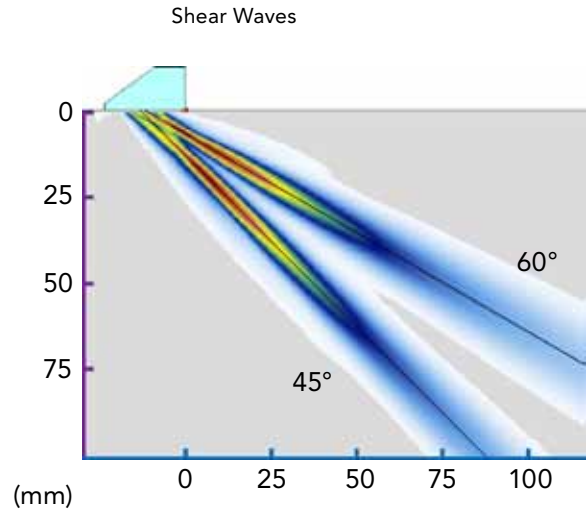
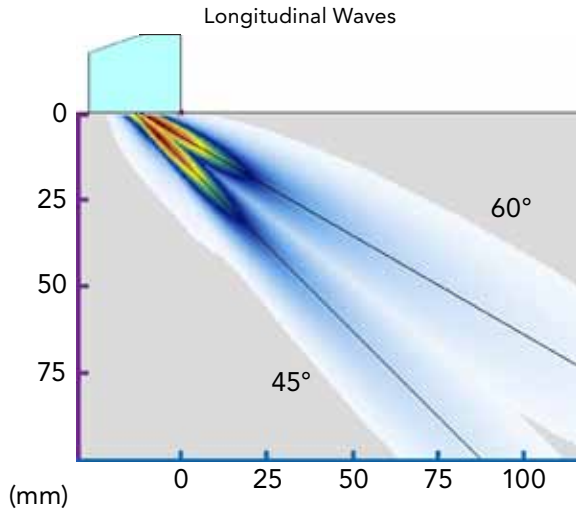

Acoustic Beam Characteristics (from Simulation Data)

Considered Active Aperture	16 elements (1 to 16)			
	45°		60°	
Angle				
Wave Type	LW	SW	LW	SW
Maximum Sound Field Depth	6.50 mm (0.256 in.)	19.00 mm (0.748 in.)	1.00 mm (0.039 in.)	6.00 mm (0.236 in.)
Focal Zone Length	28.25 mm (1.112 in.)	65.41 mm (2.575 in.)	22.91 mm (0.902 in.)	56.11 mm (2.209 in.)
Dimension in the Incident Plane	3.86 mm (0.152 in.)	3.88 mm (0.153 in.)	3.73 mm (0.147 in.)	3.89 mm (0.153 in.)
Dimension in the Perpendicular Plane	6.00 mm (0.236 in.)	6.00 mm (0.236 in.)	7.00 mm (0.276 in.)	6.00 mm (0.236 in.)

Type A - Medium - 5 MHz



Features & Benefits

- Small footprint
- Wide range of applications
- Wave layers with acoustic adaptation to Rexolite®
- Probe cable length: 5 m (16 ft.)
- Two connector types available: ZIRCON and DYNARAY compatible

Probe Specifications and Dimensions

Part ID	Frequency (MHz)	Number of elements	Primary axis Pitch	Primary axis aperture	Secondary axis aperture	External dimensions		
						L	W	H
AM-5MHz-*	5.0	16	0.60 mm (0.024 in.)	9.60 mm (0.378 in.)	10.00 mm (0.374 in.)	16.0 mm (0.630 in.)	30.0 mm (1.181 in.)	25.0 mm (0.984 in.)

(*) : -ZIRCON or -DYNARAY

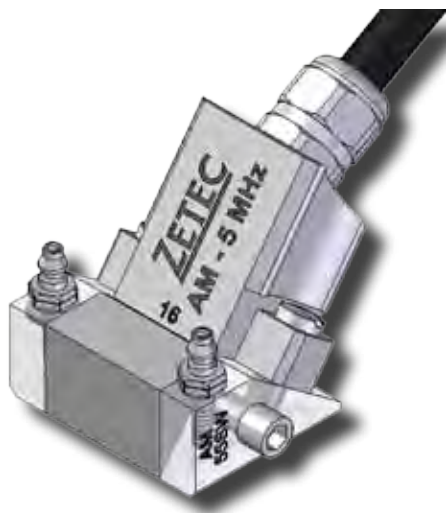

Type A - Medium / 55SW

Type A - Medium / 55LW

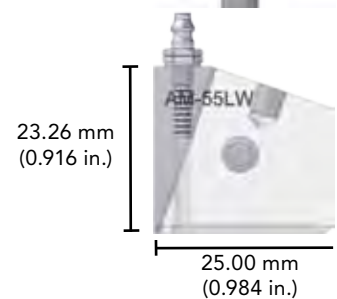
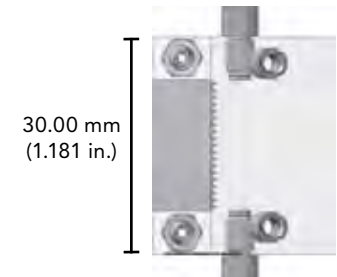
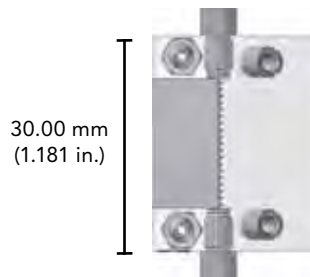

Recommended Wedges

Part ID	Wave type	Name	Nominal angle in steel	Optimized refracted beam angle range (in steel)
AM-55LW	LW	Type A - Medium / 55LW	55°	30° to 70°
AM-55SW	SW	Type A - Medium / 55SW	55°	40° to 70°

Acoustic Beam Simulation

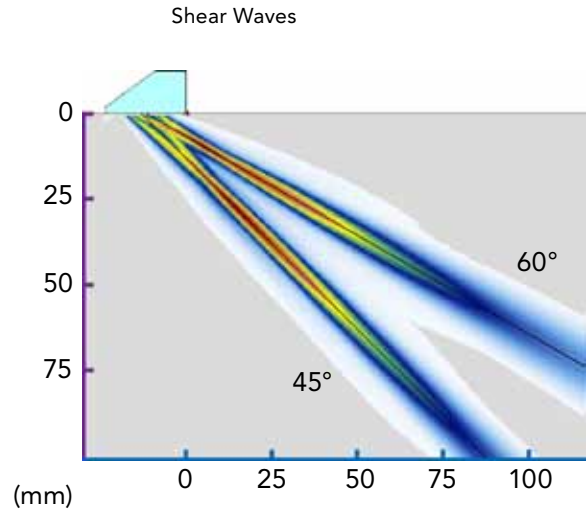
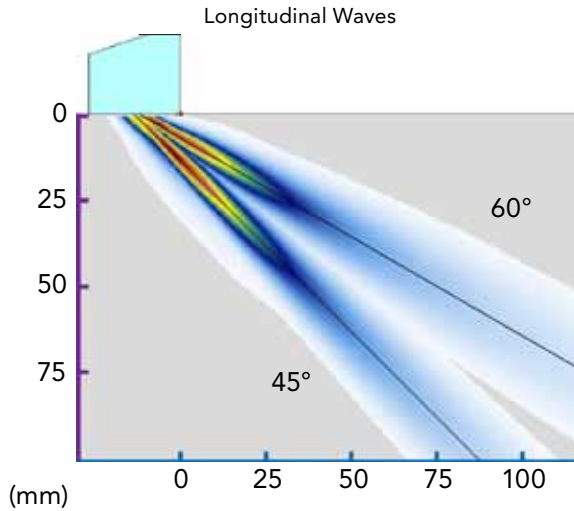

Acoustic Beam Characteristics (from Simulation Data)

Considered Active Aperture	16 elements (1 to 16)			
	45°		60°	
Angle				
Wave Type	LW	SW	LW	SW
Maximum Sound Field Depth	12.00 mm (0.472 in.)	26.00 mm (1.024 in.)	2.50 mm (0.098 in.)	9.50 mm (0.374 in.)
Focal Zone Length	43.83 mm (1.726 in.)	93.69 mm (3.689 in.)	32.40 mm (1.276 in.)	77.64 mm (3.057 in.)
Dimension in the Incident Plane	3.68 mm (0.145 in.)	4.24 mm (0.167 in.)	3.47 mm (0.137 in.)	3.92 mm (0.154 in.)
Dimension in the Perpendicular Plane	6.00 mm (0.236 in.)	7.00 mm (0.276 in.)	7.00 mm (0.276 in.)	7.00 mm (0.276 in.)

Type A - Medium - 10 MHz



Features & Benefits

- Small footprint
- Wide range of applications
- Wave layers with acoustic adaptation to Rexolite®
- Probe cable length: 5 m (16 ft.)
- Two connector types available: ZIRCON and DYNARAY compatible

Probe Specifications and Dimensions

Part ID	Frequency (MHz)	Number of elements	Primary axis Pitch	Primary axis aperture	Secondary axis aperture	External dimensions		
						L	W	H
AM-10MHz-*	10.0	32	0.31 mm (0.012 in.)	9.92 mm (0.391 in.)	10.00 mm (0.394 in.)	16.0 mm (0.630 in.)	30.0 mm (1.181 in.)	25.0 mm (0.984 in.)

(*) : -ZIRCON or -DYNARAY

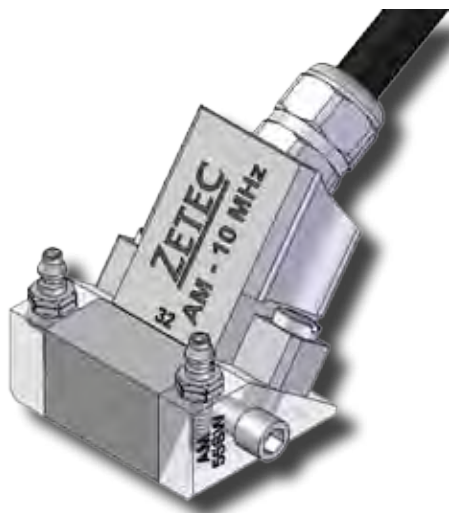

Type A - Medium / 55SW

Type A - Medium / 55LW

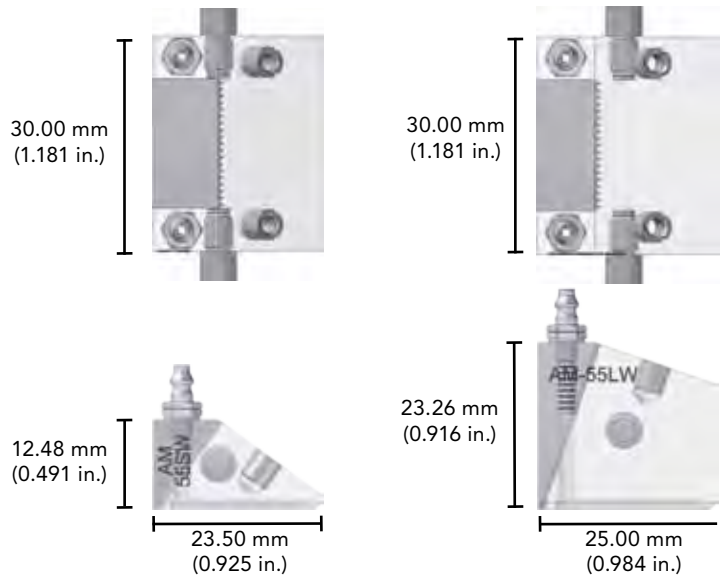

Recommended Wedges

Part ID	Wave type	Name	Nominal angle in steel	Optimized refracted beam angle range (in steel)
AM-55LW	LW	Type A - Medium / 55LW	55°	30° to 70°
AM-55SW	SW	Type A - Medium / 55SW	55°	40° to 70°

Acoustic Beam Simulation

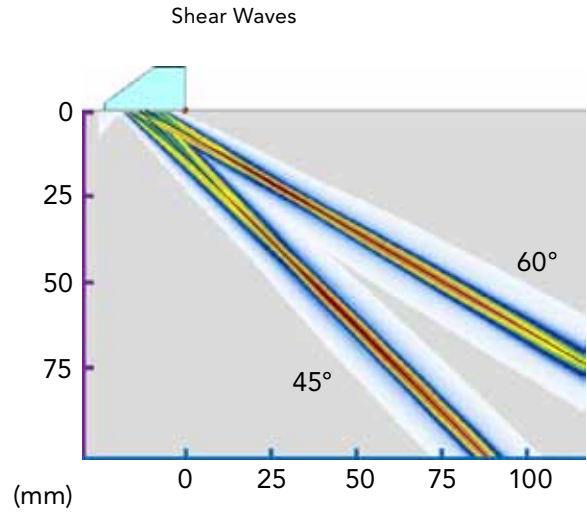
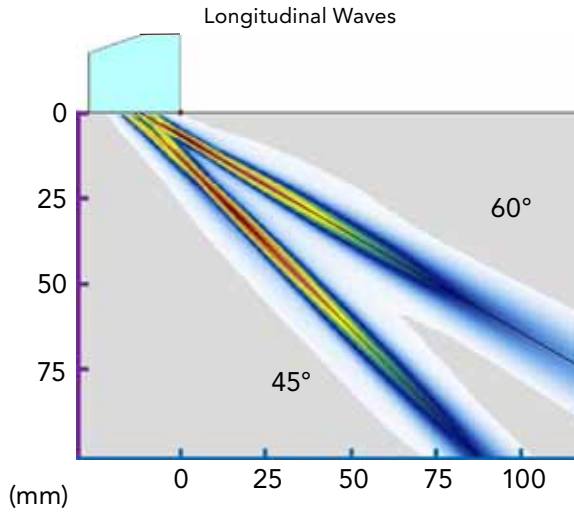

Acoustic Beam Characteristics (from Simulation Data)

Considered Active Aperture	32 elements (1 to 32)			
	45°		60°	
Angle				
Wave Type	LW	SW	LW	SW
Maximum Sound Field Depth	29.00 mm (1.142 in.)	32.00 mm (1.260 in.)	7.00 mm (0.276 in.)	21.50 mm (0.846 in.)
Focal Zone Length	95.81 mm (3.772 in.)	191.63 mm (7.544 in.)	69.14 mm (2.722 in.)	158.69 mm (6.248 in.)
Dimension in the Incident Plane	4.60 mm (0.181 in.)	5.30 mm (0.209 in.)	3.35 mm (0.132 in.)	4.37 mm (0.172 in.)
Dimension in the Perpendicular Plane	6.00 mm (0.236 in.)	7.00 mm (0.276 in.)	7.00 mm (0.276 in.)	8.00 mm (0.315 in.)

Type A - Large - 3.5 MHz

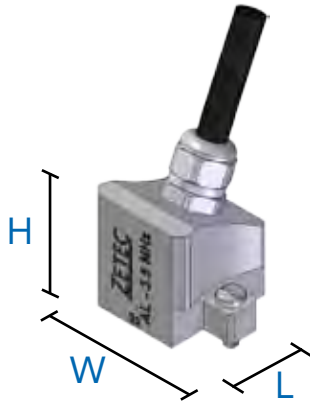

Features & Benefits

- Large active aperture for high acoustic energy
- Adapted for inspection of thick carbon steel specimens
- Wave layers with acoustic adaptation to Rexolite®
- Probe cable length: 5 m (16 ft.)
- Two connector types available: ZIRCON and DYNARAY compatible

Probe Specifications and Dimensions

Part ID	Frequency (MHz)	Number of elements	Primary axis Pitch	Primary axis aperture	Secondary axis aperture	External dimensions		
						L	W	H
AL-3.5MHz-*	3.5	32	0.60 mm (0.024 in.)	19.20 mm (0.756 in.)	15.00 mm (0.591 in.)	24.0 mm (0.945 in.)	33.0 mm (1.299 in.)	25.0 mm (0.984 in.)

(*) : -ZIRCON or -DYNARAY



Type A - Large / 55SW

Type A - Large / 55LW

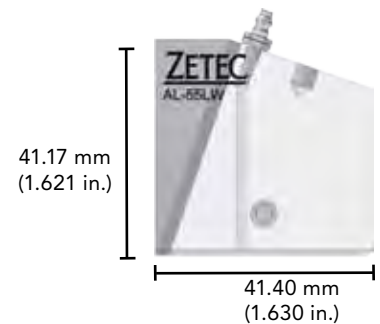
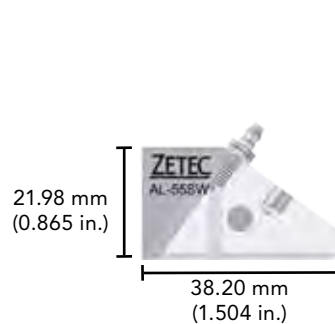
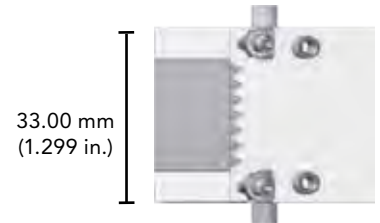
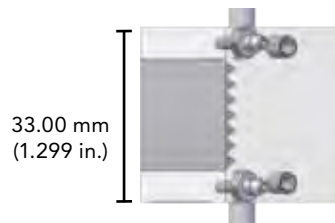

Recommended Wedges

Part ID	Wave type	Name	Nominal angle in steel	Optimized refracted beam angle range (in steel)
AL-55LW	LW	Type A - Large / 55LW	55°	30° to 70°
AL-55SW	SW	Type A - Large / 55SW	55°	40° to 70°

Acoustic Beam Simulation

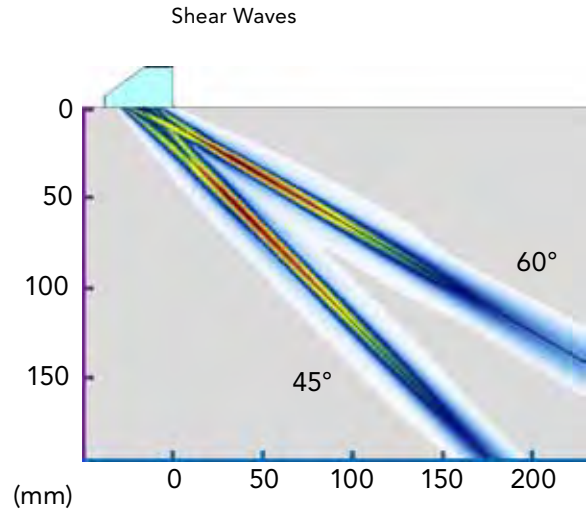
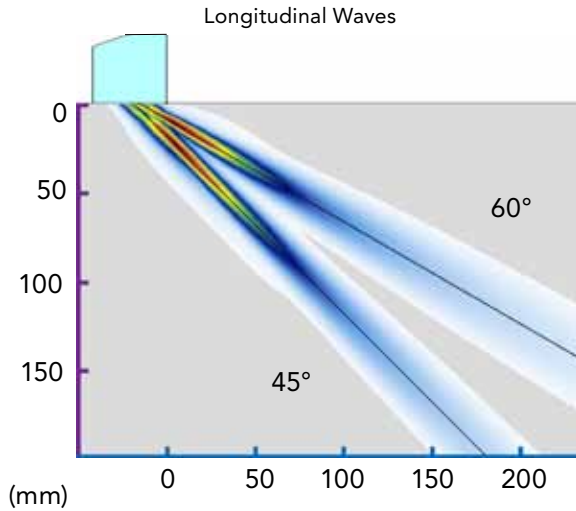

Acoustic Beam Characteristics (from Simulation Data)

Considered Active Aperture	32 elements (1 to 32)			
	45°		60°	
Angle				
Wave Type	LW	SW	LW	SW
Maximum Sound Field Depth	24.00 mm (0.945 in.)	54.50 mm (2.146 in.)	11.00 mm (0.433 in.)	29.00 mm (1.142 in.)
Focal Zone Length	81.31 mm (3.201 in.)	165.46 mm (6.514 in.)	67.25 mm (2.647 in.)	145.42 mm (5.725 in.)
Dimension in the Incident Plane	6.39 mm (0.252 in.)	6.72 mm (0.265 in.)	5.64 mm (0.222 in.)	6.02 mm (0.237 in.)
Dimension in the Perpendicular Plane	6.00 mm (0.236 in.)	6.00 mm (0.236 in.)	8.00 mm (0.315 in.)	8.00 mm (0.315 in.)

Type A - Large - 5 MHz

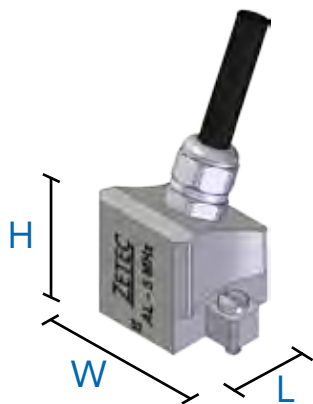

Features & Benefits

- Large active aperture for high acoustic energy
- Adapted for inspection of thick carbon steel specimens
- Wave layers with acoustic adaptation to Rexolite®
- Probe cable length: 5 m (16 ft.)
- Two connector types available: ZIRCON and DYNARAY compatible

Probe Specifications and Dimensions

Part ID	Frequency (MHz)	Number of elements	Primary axis Pitch	Primary axis aperture	Secondary axis aperture	External dimensions		
						L	W	H
AL-5MHz-*	5.0	32	0.60 mm (0.024 in.)	19.20 mm (0.756 in.)	15.00 mm (0.591 in.)	24.0 mm (0.945 in.)	33.0 mm (1.299 in.)	25.0 mm (0.984 in.)

(*) : -ZIRCON or -DYNARAY



Type A - Large / 55SW

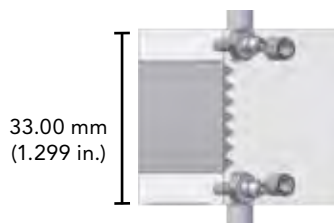

Type A - Large / 55LW

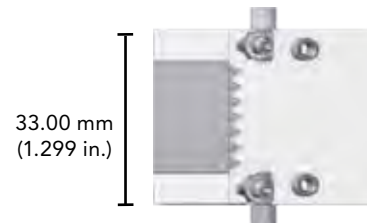

Recommended Wedges

Part ID	Wave type	Name	Nominal angle in steel	Optimized refracted beam angle range (in steel)
AL-55LW	LW	Type A - Large / 55LW	55°	30° to 70°
AL-55SW	SW	Type A - Large / 55SW	55°	40° to 70°

Acoustic Beam Simulation

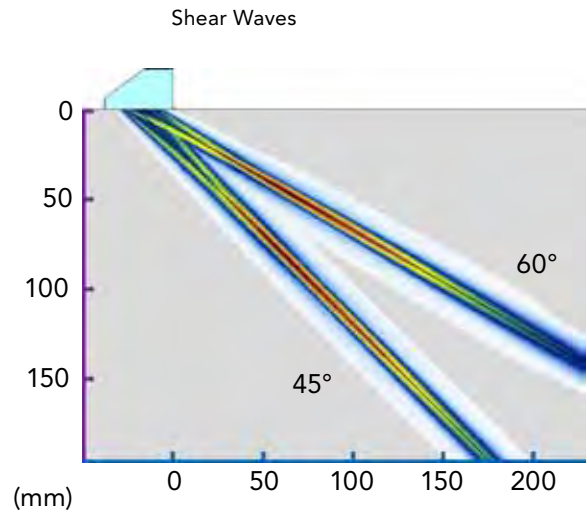
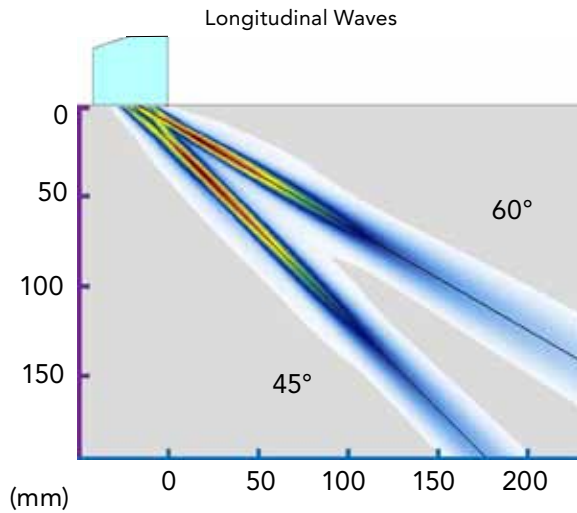

Acoustic Beam Characteristics (from Simulation Data)

Considered Active Aperture	32 elements (1 to 32)			
	45°		60°	
Angle				
Wave Type	LW	SW	LW	SW
Maximum Sound Field Depth	39.00 mm (1.535 in.)	73.50 mm (2.894 in.)	18.00 mm (0.709 in.)	43.50 mm (1.713 in.)
Focal Zone Length	120.56 mm (4.746 in.)	221.68 mm (8.728 in.)	99.95 mm (3.935 in.)	208.55 mm (8.211 in.)
Dimension in the Incident Plane	6.39 mm (0.252 in.)	6.03 mm (0.237 in.)	5.90 mm (0.232 in.)	6.52 mm (0.257 in.)
Dimension in the Perpendicular Plane	7.00 mm (0.276 in.)	6.00 mm (0.236 in.)	9.00 mm (0.354 in.)	9.00 mm (0.354 in.)

Type A - X-Large - 1.5 MHz

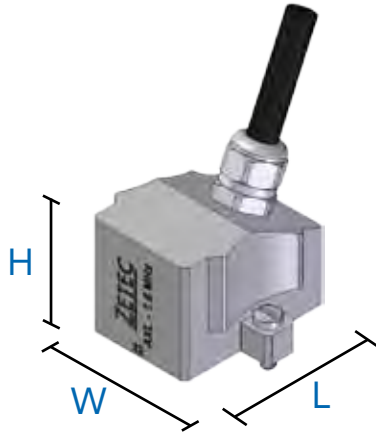

Features & Benefits

- Large active aperture for high acoustic energy
- Adapted for inspection of thick stainless steel specimens
- Wave layers with acoustic adaptation to Rexolite®
- Probe cable length: 5 m (16 ft.)
- Two connector types available: ZIRCON and DYNARAY compatible

Probe Specifications and Dimensions

Part ID	Frequency (MHz)	Number of elements (Primary axis)	Primary axis Pitch	Primary axis aperture	Secondary axis aperture	External dimensions		
						L	W	H
AXL-1.5MHz-*	1.5	32	1.00 mm (0.039 in.)	32.00 mm (1.260 in.)	20.00 mm (0.787 in.)	36.0 mm (1.417 in.)	38.0 mm (1.496 in.)	25.0 mm (0.984 in.)

(*) : -ZIRCON or -DYNARAY



Type A - Xlarge / 55SW

Type A - Xlarge / 55LW

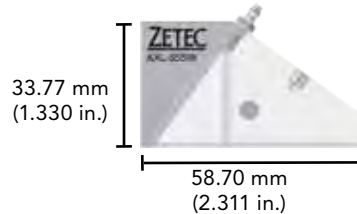
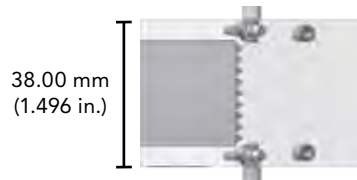

Recommended Wedges

Part ID	Wave type	Name	Nominal angle in steel	Optimized refracted beam angle range (in steel)
AXL-55LW	LW	Type A - Xlarge / 55LW	55°	30° to 70°
AXL-55SW	SW	Type A - Xlarge / 55SW	55°	40° to 70°

Acoustic Beam Simulation

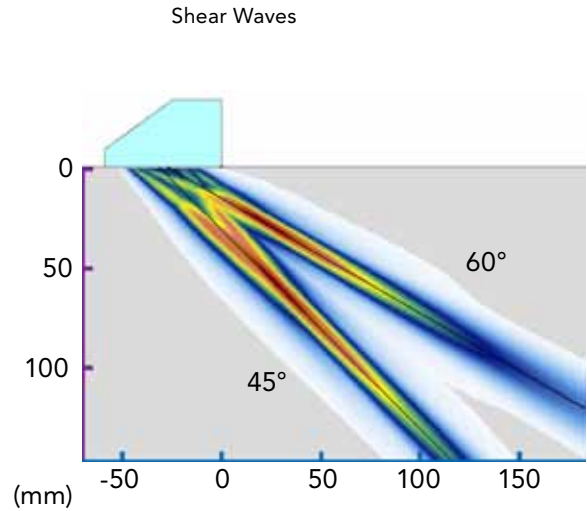
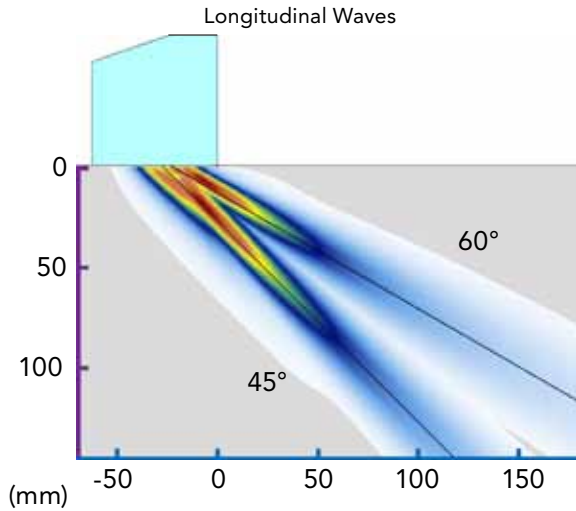

Acoustic Beam Characteristics (from Simulation Data)

Considered Active Aperture	32 elements (1 to 32)			
	45°		60°	
Angle				
Wave Type	LW	SW	LW	SW
Maximum Sound Field Depth	18.00 mm (0.709 in.)	56.50 mm (2.224 in.)	6.50 mm (0.256 in.)	29.00 mm (1.142 in.)
Focal Zone Length	85.95 mm (3.384 in.)	175.75 mm (6.919 in.)	61.50 mm (2.421 in.)	161.46 mm (6.357 in.)
Dimension in the Incident Plane	13.75 mm (0.541 in.)	14.65 mm (0.577 in.)	8.98 mm (0.354 in.)	8.65 mm (0.341 in.)
Dimension in the Perpendicular Plane	10.00 mm (0.394 in.)	10.00 mm (0.394 in.)	8.00 mm (0.315 in.)	8.00 mm (0.315 in.)

Type A - X-Large - 2.25 MHz

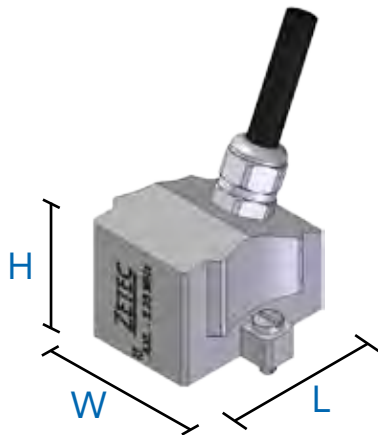

Features & Benefits

- Large active aperture for high acoustic energy
- Adapted for inspection of thick stainless steel specimens
- Wave layers with acoustic adaptation to Rexolite®
- Probe cable length: 5 m (16 ft.)
- Two connector types available: ZIRCON and DYNARAY compatible

Probe Specifications and Dimensions

Part ID	Frequency (MHz)	Number of elements (Primary axis)	Primary axis Pitch	Primary axis aperture	Secondary axis aperture	External dimensions		
						L	W	H
AXL-2.25MHz-*	2.25	32	1.00 mm (0.039 in.)	32.00 mm (1.260 in.)	20.00 mm (0.787 in.)	36.0 mm (1.417 in.)	38.0 mm (1.496 in.)	25.0 mm (0.984 in.)

(*) : -ZIRCON or -DYNARAY

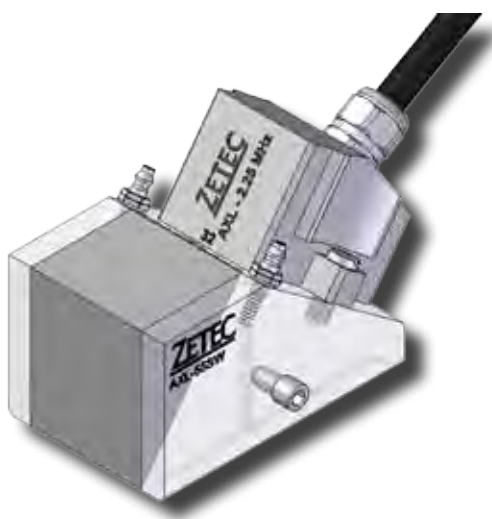

Type A - Xlarge / 55SW

Type A - Xlarge / 55LW

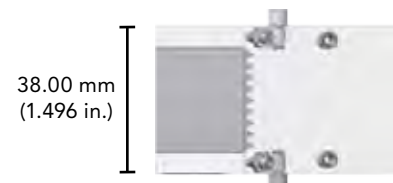
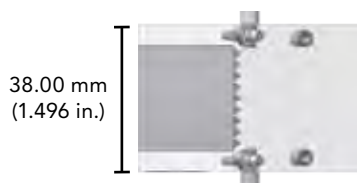

Recommended Wedges

Part ID	Wave type	Name	Nominal angle in steel	Optimized refracted beam angle range (in steel)
AXL-55LW	LW	Type A - Xlarge / 55LW	55°	30° to 70°
AXL-55SW	SW	Type A - Xlarge / 55SW	55°	40° to 70°

Acoustic Beam Simulation

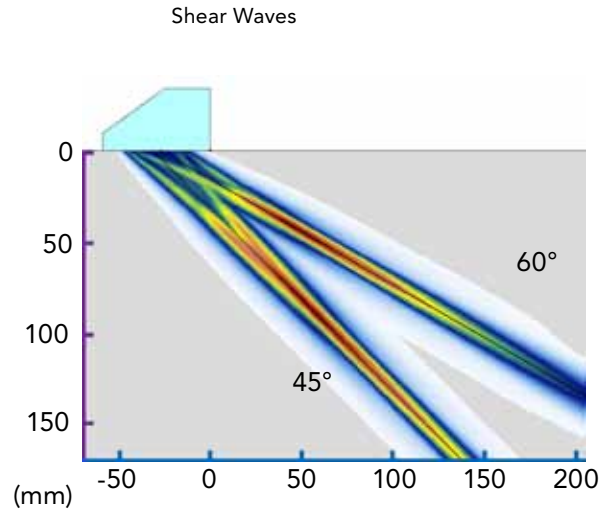
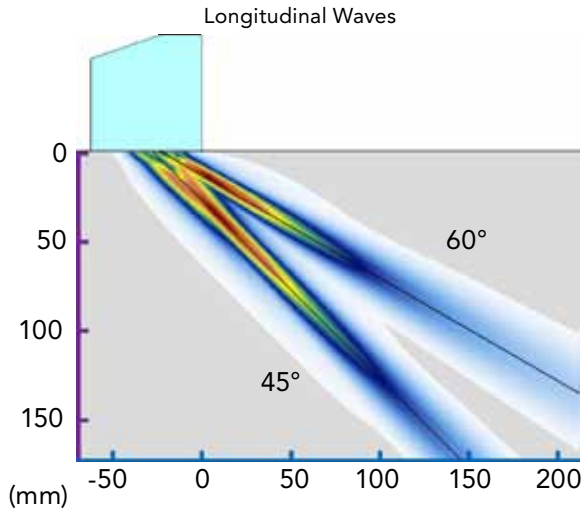

Acoustic Beam Characteristics (from Simulation Data)

Considered Active Aperture	32 elements (1 to 32)			
	45°		60°	
Angle				
Wave Type	LW	SW	LW	SW
Maximum Sound Field Depth	33.00 mm (1.299 in.)	88.00 mm (3.465 in.)	14.50 mm (0.571 in.)	40.00 mm (1.575 in.)
Focal Zone Length	124.46 mm (4.900 in.)	235.83 mm (9.285 in.)	82.94 mm (3.265 in.)	181.44 mm (7.143 in.)
Dimension in the Incident Plane	12.37 mm (0.487 in.)	12.70 mm (0.500 in.)	8.00 mm (0.315 in.)	8.02 mm (0.316 in.)
Dimension in the Perpendicular Plane	9.00 mm (0.354 in.)	10.00 mm (0.394 in.)	8.00 mm (0.315 in.)	8.00 mm (0.315 in.)

Probes for Linear Scanning



Type L - Medium - 2.25 MHz

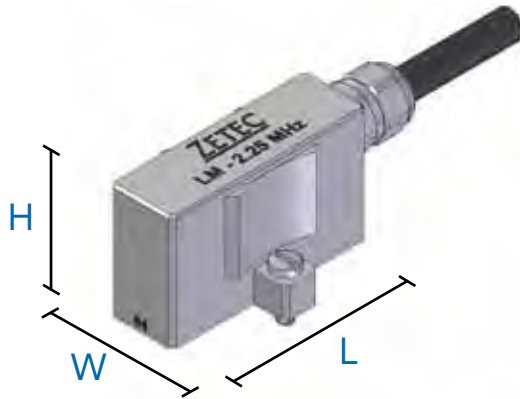

Features & Benefits

- Large aperture for linear scan
- Wide range of applications
- Wave layers with acoustic adaptation to Rexolite®
- Probe cable length: 5 m (16 ft.)
- Two connector types available: ZIRCON and DYNARAY compatible

Probe Specifications and Dimensions

Part ID	Frequency (MHz)	Number of elements (Primary axis)	Primary axis Pitch	Primary axis aperture	Secondary axis aperture	External dimensions		
						L	W	H
LM-2.25MHz-*	2.25	64	0.60 mm (0.024 in.)	38.40 mm (1.512 in.)	10.00 mm (0.394 in.)	43.0 mm (1.693 in.)	28.0 mm (1.102 in.)	25.0 mm (0.984 in.)

(*) : -ZIRCON or -DYNARAY

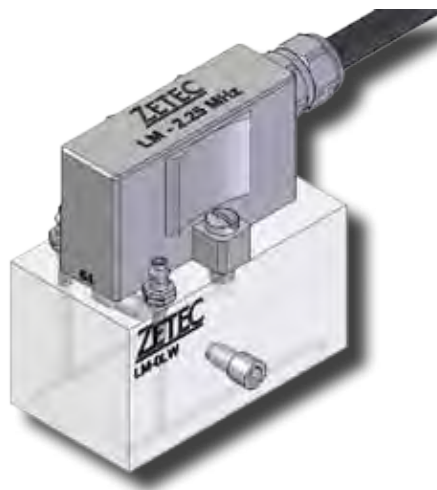

Recommended Wedges

Part ID	Wave type	Name	Nominal angle in steel	Optimized refracted beam angle range (in steel)
LM-0LW	LW	Type L - Medium / 0LW	0°	-25° to 25°
LM-55LW	LW	Type L - Medium / 55LW	55°	40° to 70°
LM-55SW	SW	Type L - Medium / 55SW	55°	40° to 70°

Wedges Dimensions

Type L - Medium / 55LW

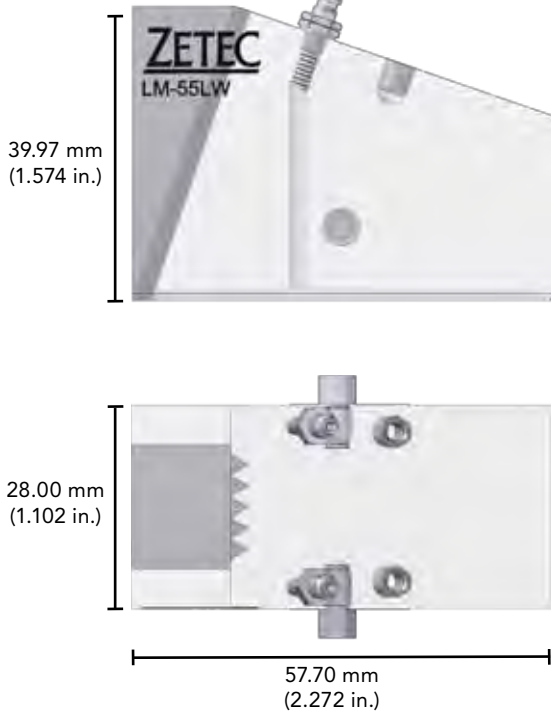

Type L - Medium / 55SW

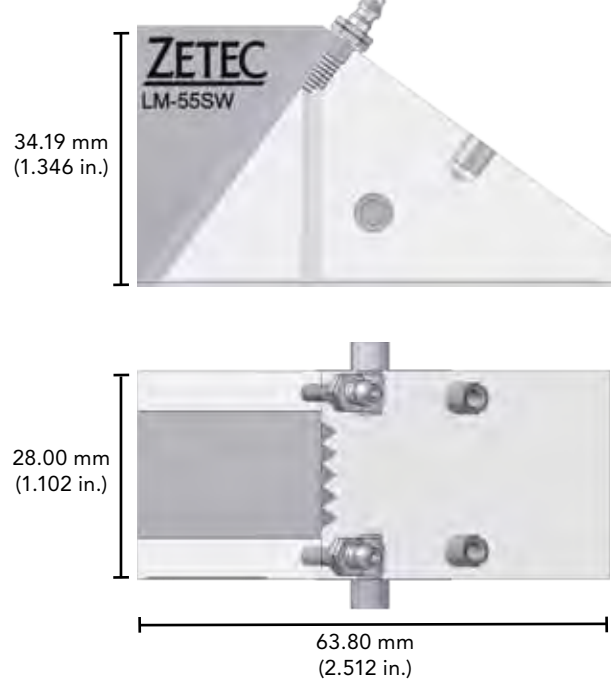

Type L - Medium / 0LW

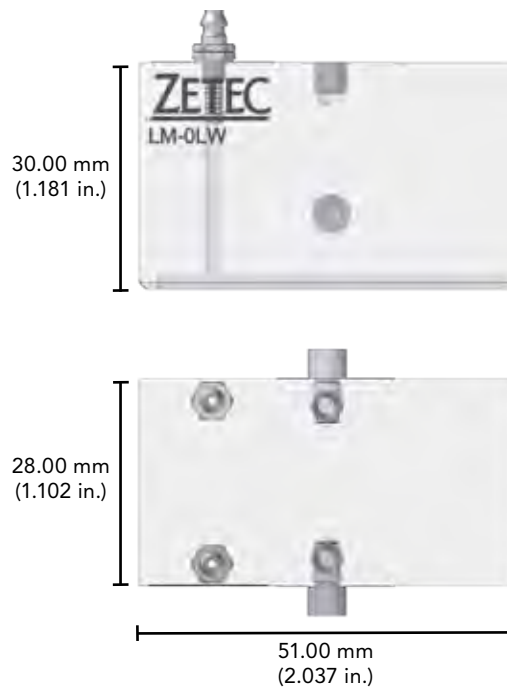

Type L - Medium - 2.25 MHz (continued)

0° - Acoustic Beam Simulation

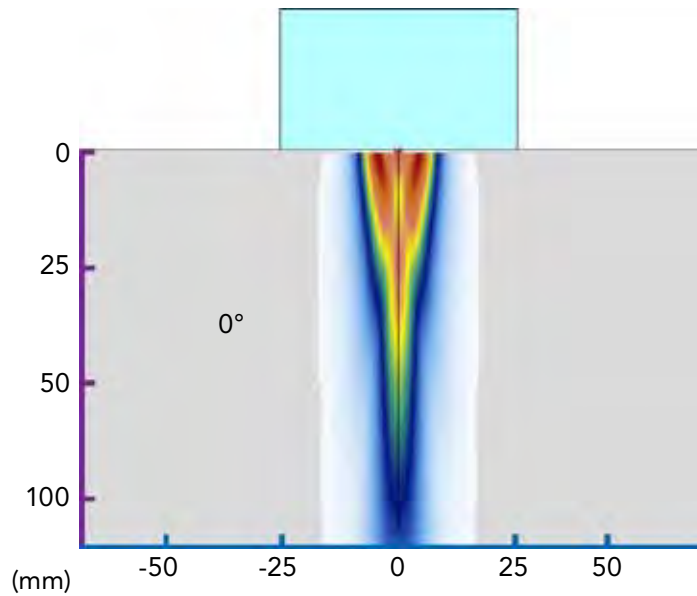

45° - Acoustic Beam Simulation

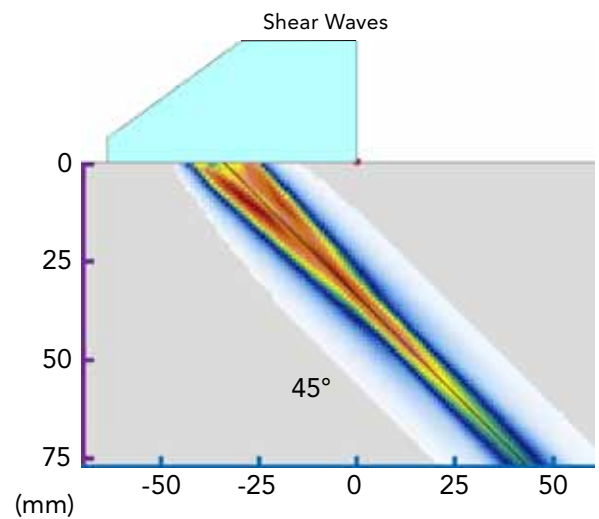
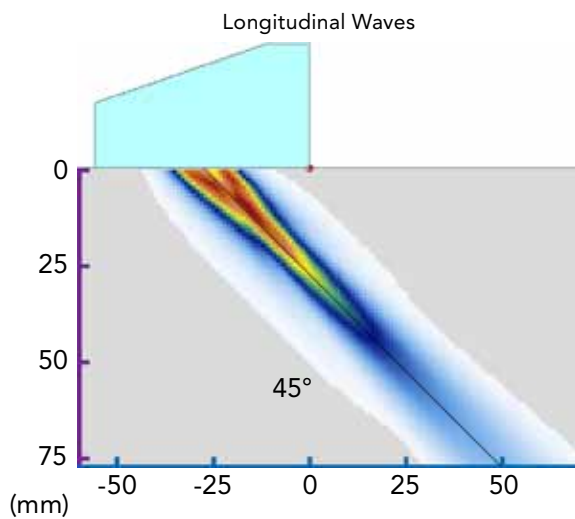

60° - Acoustic Beam Simulation

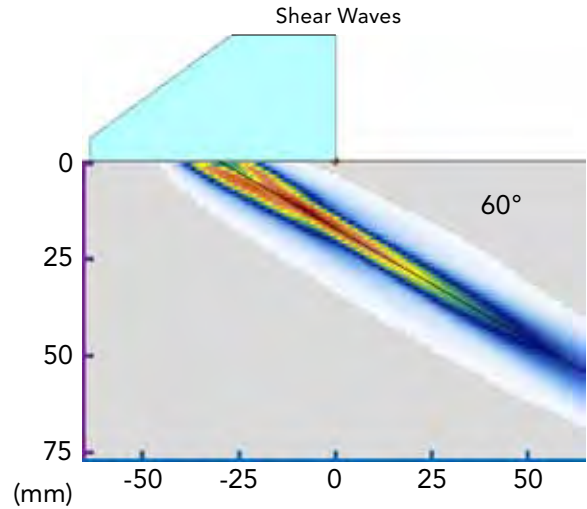
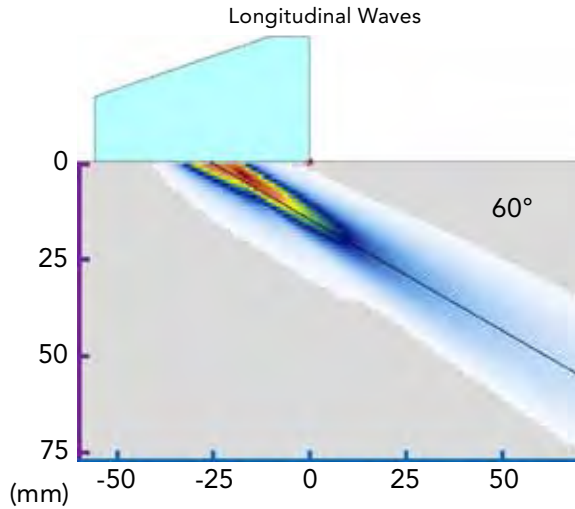

Acoustic Beam Characteristics (from Simulation Data)

Considered Active Aperture	32 elements (17 to 48)				
	0°	45°		60°	
Angle					
Wave Type	LW	LW	SW	LW	SW
Maximum Sound Field Depth	1.00 mm (0.039 in.)	10.00 mm (0.394 in.)	11.00 mm (0.433 in.)	4.00 mm (0.157 in.)	13.00 mm (0.512 in.)
Focal Zone Length	46.50 mm (1.831 in.)	46.02 mm (1.812 in.)	93.37 mm (3.676 in.)	29.38 mm (1.157 in.)	69.23 mm (2.726 in.)
Dimension in the Incident Plane	14.00 mm (0.551 in.)	9.16 mm (0.361 in.)	10.62 mm (0.418 in.)	5.64 mm (0.222 in.)	7.53 mm (0.296 in.)
Dimension in the Perpendicular Plane	6.00 mm (0.236 in.)	6.00 mm (0.236 in.)	6.00 mm (0.236 in.)	4.00 mm (0.157 in.)	6.00 mm (0.236 in.)

Type L - Medium - 3.5 MHz

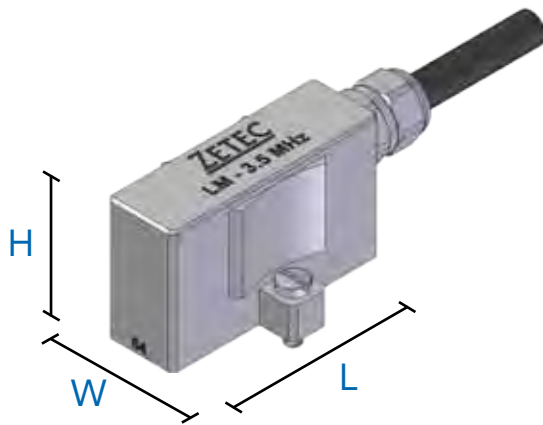

Features & Benefits

- Large aperture for linear scan
- Wide range of applications
- Wave layers with acoustic adaptation to Rexolite®
- Probe cable length: 5 m (16 ft.)
- Two connector types available: ZIRCON and DYNARAY compatible

Probe Specifications and Dimensions

Part ID	Frequency (MHz)	Number of elements	Primary axis Pitch	Primary axis aperture	Secondary axis aperture	External dimensions		
						L	W	H
LM-3.5MHz-*	3.5	64	0.60 mm (0.024 in.)	38.40 mm (1.512 in.)	10.00 mm (0.394 in.)	43.0 mm (1.693 in.)	28.0 mm (1.102 in.)	25.0 mm (0.984 in.)

(*) : -ZIRCON or -DYNARAY

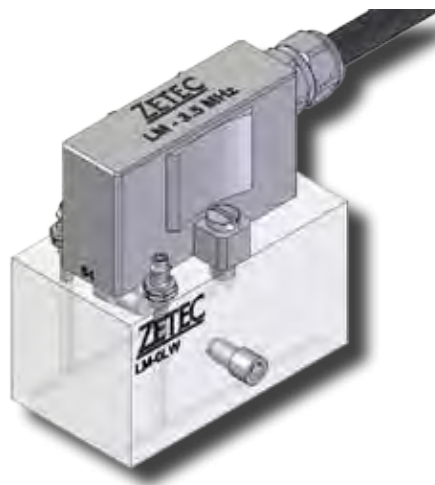

Recommended Wedges

Part ID	Wave type	Name	Nominal angle in steel	Optimized refracted beam angle range (in steel)
LM-0LW	LW	Type L - Medium / 0LW	0°	-25° to 25°
LM-55LW	LW	Type L - Medium / 55LW	55°	40° to 70°
LM-55SW	SW	Type L - Medium / 55SW	55°	40° to 70°

Wedges Dimensions

Type L - Medium / 55LW

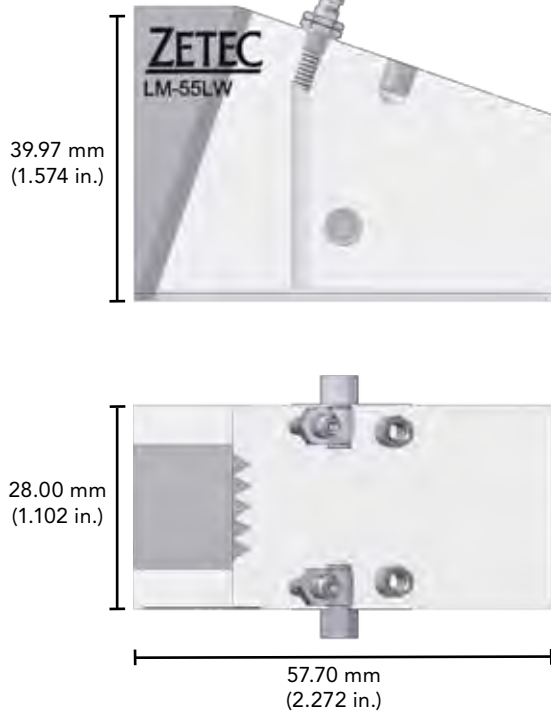

Type L - Medium / 55SW

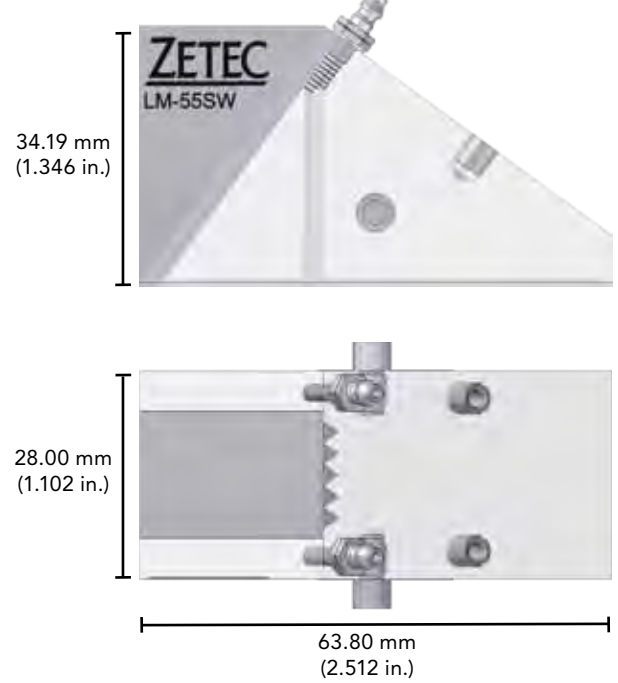

Type L - Medium / 0LW

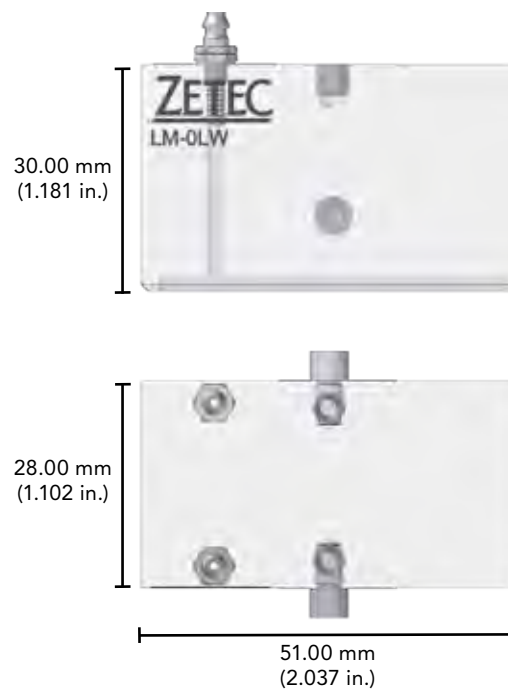

Type L - Medium - 3.5 MHz (continued)

0° - Acoustic Beam Simulation

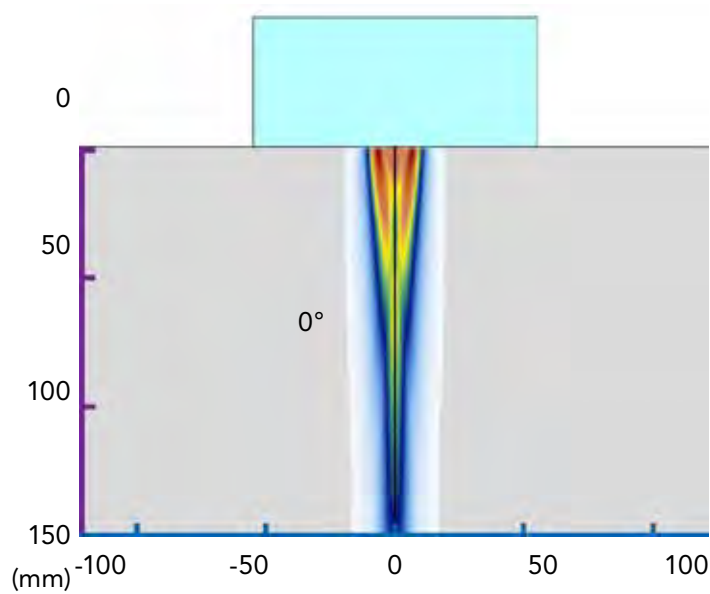

45° - Acoustic Beam Simulation

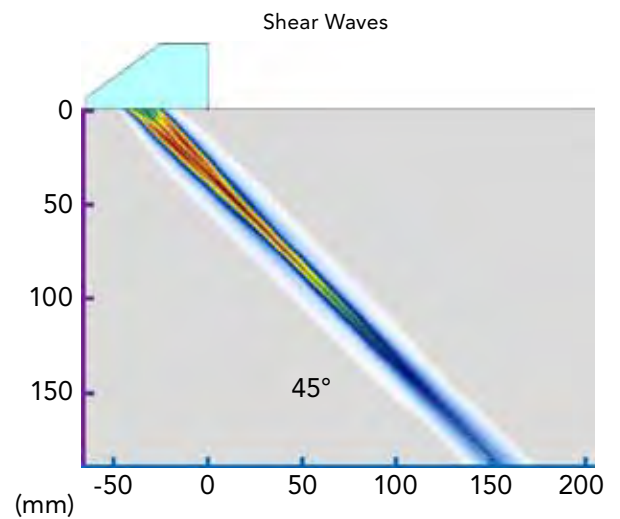
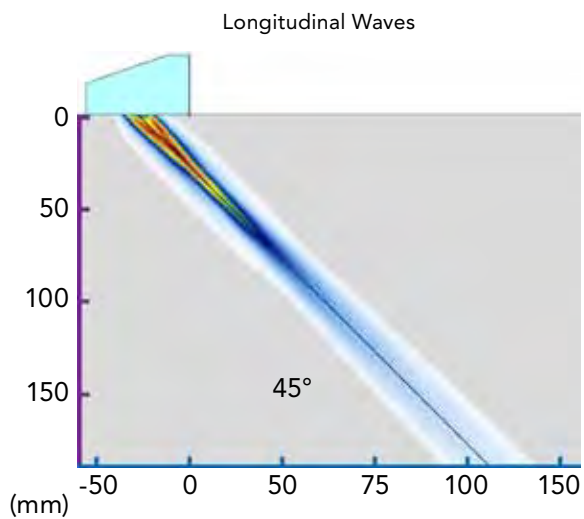

60° - Acoustic Beam Simulation

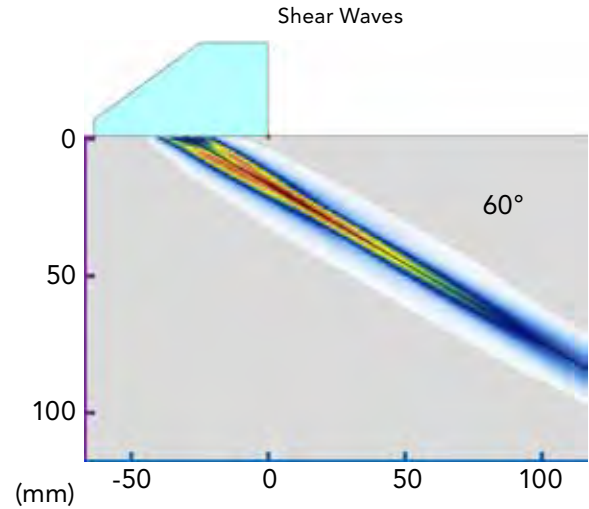
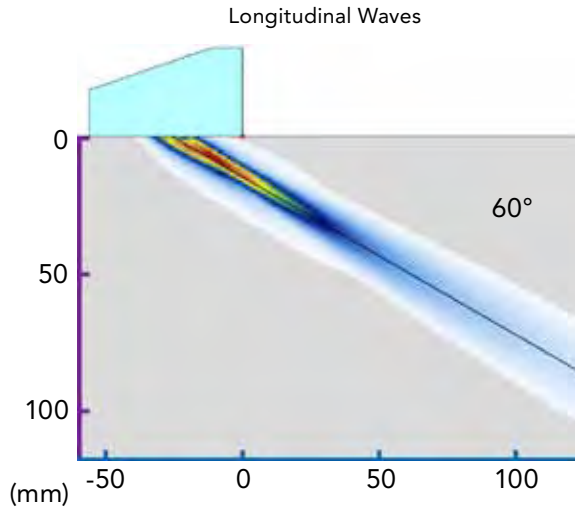

Acoustic Beam Characteristics (from Simulation Data)

Considered Active Aperture	32 elements (17 to 48)				
	0°	45°		60°	
Angle					
Wave Type	LW	LW	SW	LW	SW
Maximum Sound Field Depth	10.00 mm (0.394 in.)	18.00 mm (0.709 in.)	43.00 mm (1.693 in.)	8.00 mm (0.315 in.)	20.00 mm (0.787 in.)
Focal Zone Length	82.00 mm (3.228 in.)	68.63 mm (2.702 in.)	142.85 mm (5.624 in.)	43.79 mm (1.724 in.)	97.49 mm (3.838 in.)
Dimension in the Incident Plane	14.00 mm (0.551 in.)	9.22 mm (0.363 in.)	10.59 mm (0.417 in.)	5.31 mm (0.209 in.)	7.08 mm (0.279 in.)
Dimension in the Perpendicular Plane	6.00 mm (0.236 in.)	6.00 mm (0.236 in.)	6.00 mm (0.236 in.)	4.00 mm (0.157 in.)	6.00 mm (0.236 in.)

Type L - Medium - 5 MHz

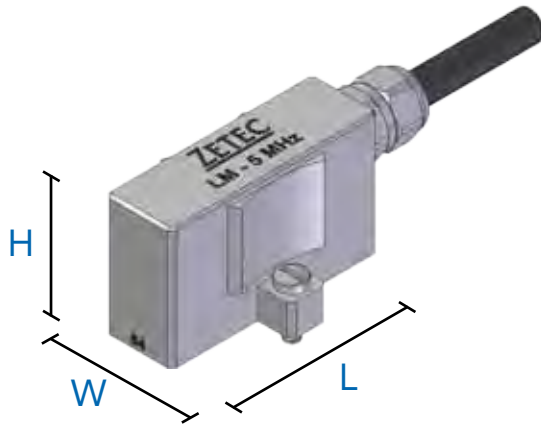

Features & Benefits

- Large aperture for linear scan
- Wide range of applications
- Wave layers with acoustic adaptation to Rexolite®
- Probe cable length: 5 m (16 ft.)
- Two connector types available: ZIRCON and DYNARAY compatible

Probe Specifications and Dimensions

Part ID	Frequency (MHz)	Number of elements (Primary axis)	Primary axis Pitch	Primary axis aperture	Secondary axis aperture	External dimensions		
						L	W	H
LM-5MHz-*	5.0	64	0.60 mm (0.024 in.)	38.40 mm (1.512 in.)	10.00 mm (0.394 in.)	43.0 mm (1.693 in.)	28.0 mm (1.102 in.)	25.0 mm (0.984 in.)

(*) : -ZIRCON or -DYNARAY

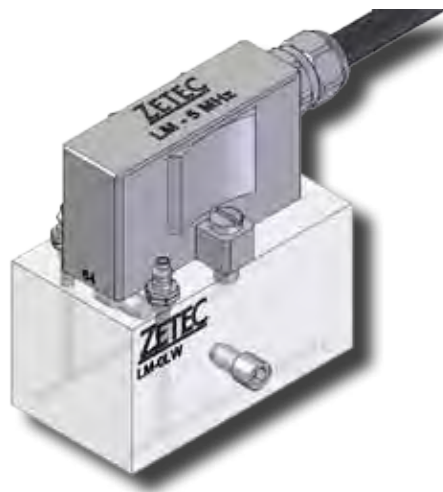

Recommended Wedges

Part ID	Wave type	Name	Nominal angle in steel	Optimized refracted beam angle range (in steel)
LM-0LW	LW	Type L - Medium / 0LW	0°	-25° to 25°
LM-55LW	LW	Type L - Medium / 55LW	55°	40° to 70°
LM-55SW	SW	Type L - Medium / 55SW	55°	40° to 70°

Wedges Dimensions

Type L - Medium / 55LW

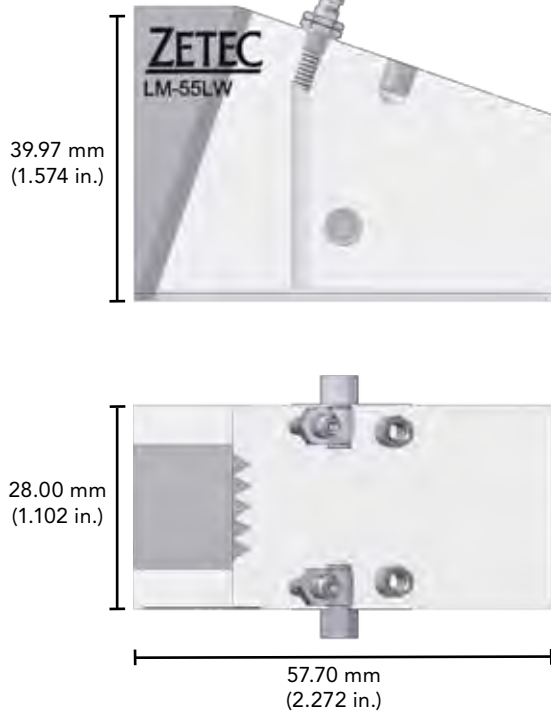

Type L - Medium / 55SW

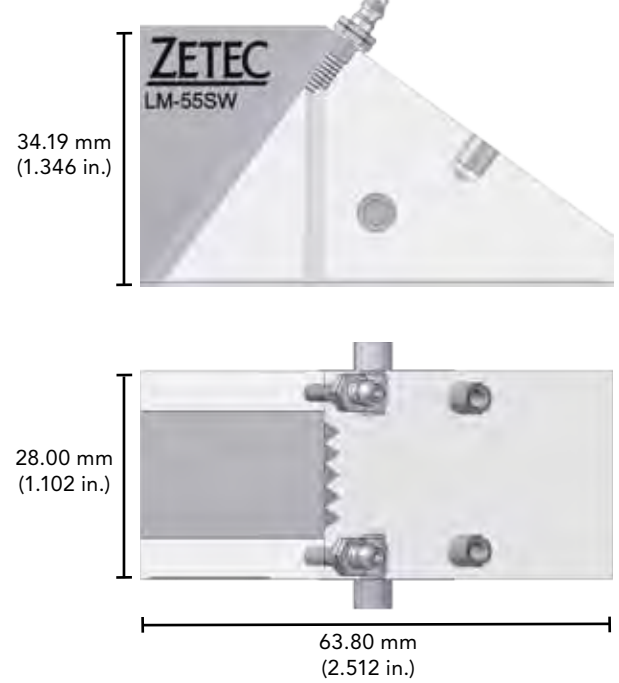

Type L - Medium / 0LW

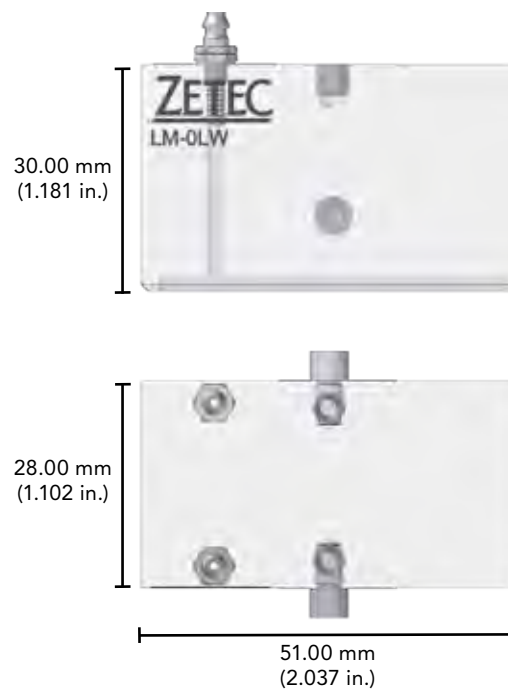

Type L - Medium - 5 MHz (continued)

0° - Acoustic Beam Simulation

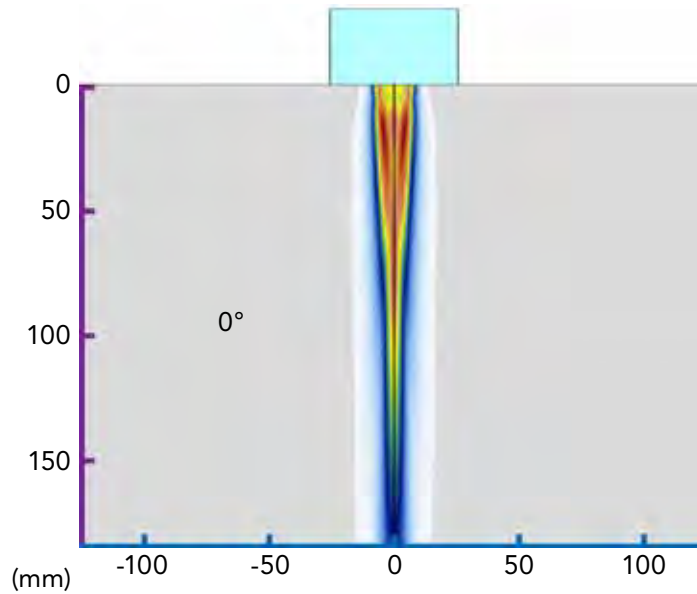

45° - Acoustic Beam Simulation

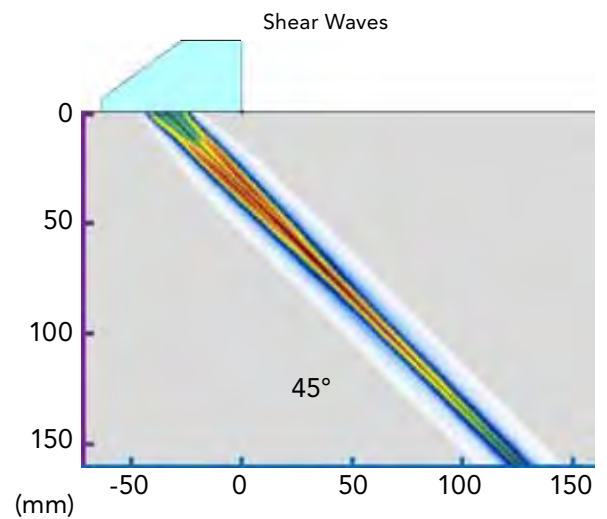
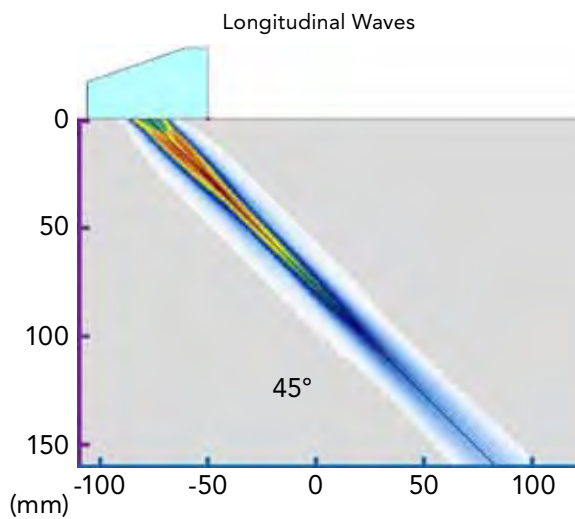

60° - Acoustic Beam Simulation

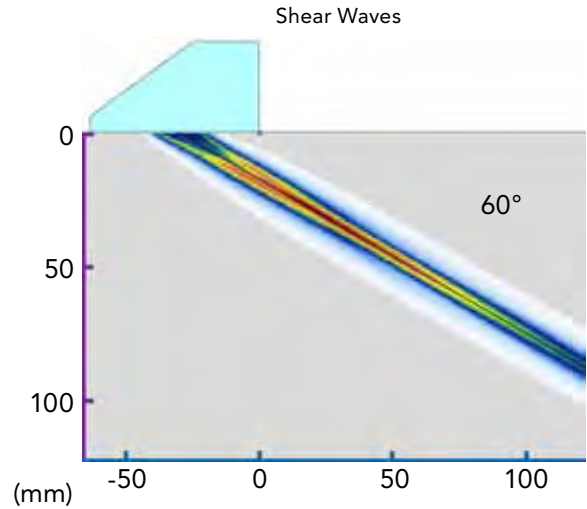
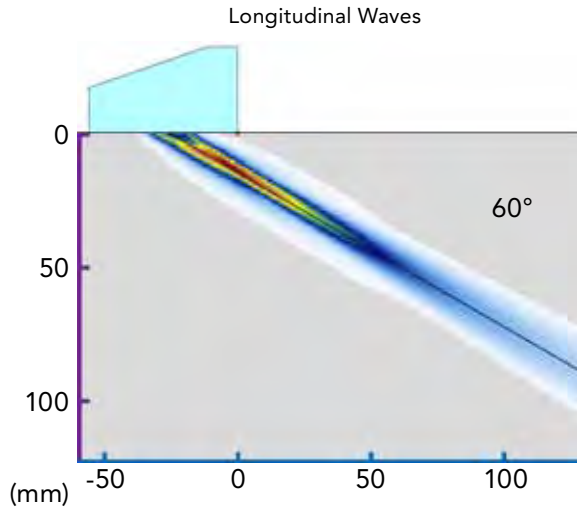

Acoustic Beam Characteristics (from Simulation Data)

Considered Active Aperture	32 elements (17 to 48)				
	0°	45°		60°	
Angle					
Wave Type	LW	LW	SW	LW	SW
Maximum Sound Field Depth	18.50 mm (0.728 in.)	28.00 mm (1.102 in.)	65.00 mm (2.559 in.)	12.00 mm (0.472 in.)	31.00 mm (1.220 in.)
Focal Zone Length	126.50 mm (4.980 in.)	95.48 mm (3.759 in.)	199.41 mm (7.851 in.)	56.81 mm (2.237 in.)	130.23 mm (5.127 in.)
Dimension in the Incident Plane	14.00 mm (0.551 in.)	9.22 mm (0.363 in.)	10.60 mm (0.417 in.)	4.97 mm (0.196 in.)	6.61 mm (0.260 in.)
Dimension in the Perpendicular Plane	7.00 mm (0.276 in.)	6.00 mm (0.236 in.)	6.00 mm (0.236 in.)	4.00 mm (0.157 in.)	4.00 mm (0.157 in.)

Type L - Medium - 10 MHz

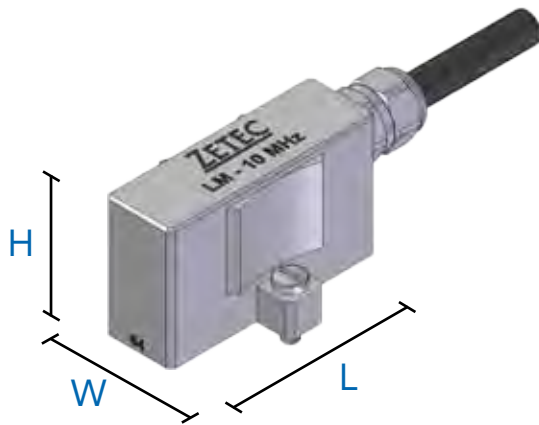

Features & Benefits

- Large aperture for linear scan
- Wide range of applications
- Wave layers with acoustic adaptation to Rexolite®
- Probe cable length: 5 m (16 ft.)
- Two connector types available: ZIRCON and DYNARAY compatible

Probe Specifications and Dimensions

Part ID	Frequency (MHz)	Number of elements (Primary axis)	Primary axis Pitch	Primary axis aperture	Secondary axis aperture	External dimensions		
						L	W	H
LM-10MHz-*	10.0	64	0.60 mm (0.024 in.)	38.40 mm (1.512 in.)	10.00 mm (0.394 in.)	43.0 mm (1.693 in.)	28.0 mm (1.102 in.)	25.0 mm (0.984 in.)

(*) : -ZIRCON or -DYNARAY

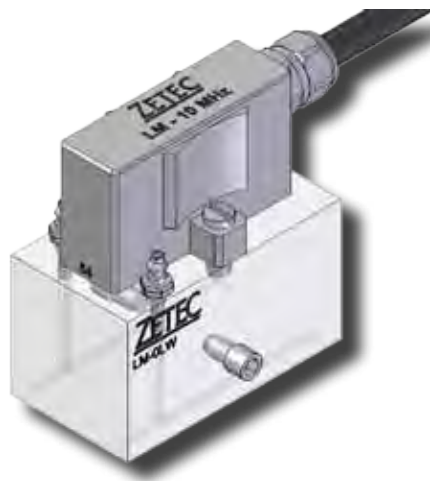

Recommended Wedges

Part ID	Wave type	Name	Nominal angle in steel	Optimized refracted beam angle range (in steel)
LM-0LW	LW	Type L - Medium / 0LW	0°	-25° to 25°
LM-55LW	LW	Type L - Medium / 55LW	55°	40° to 70°
LM-55SW	SW	Type L - Medium / 55SW	55°	40° to 70°

Wedges Dimensions

Type L - Medium / 55LW

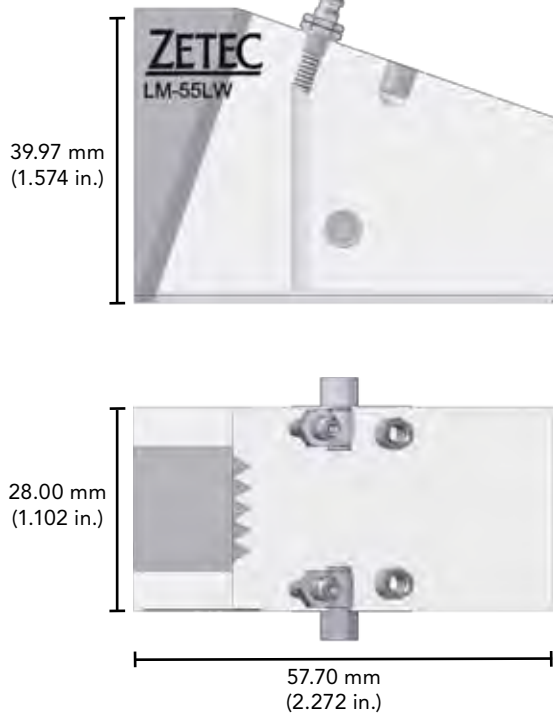

Type L - Medium / 55SW

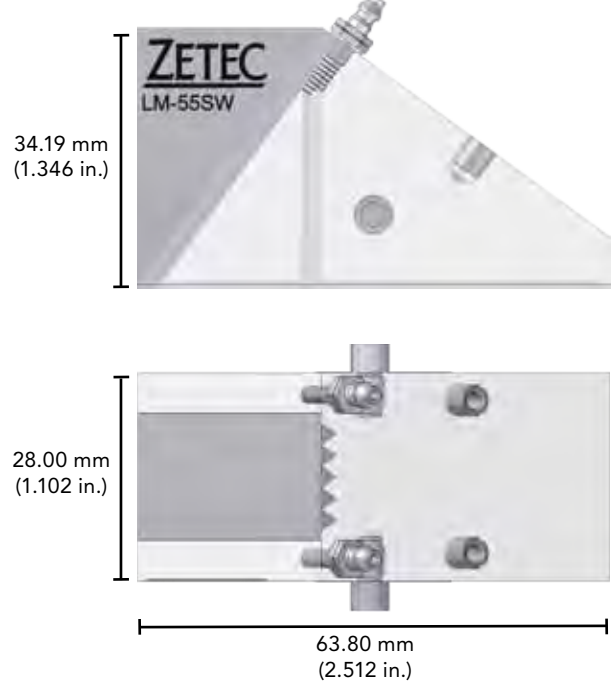

Type L - Medium / 0LW

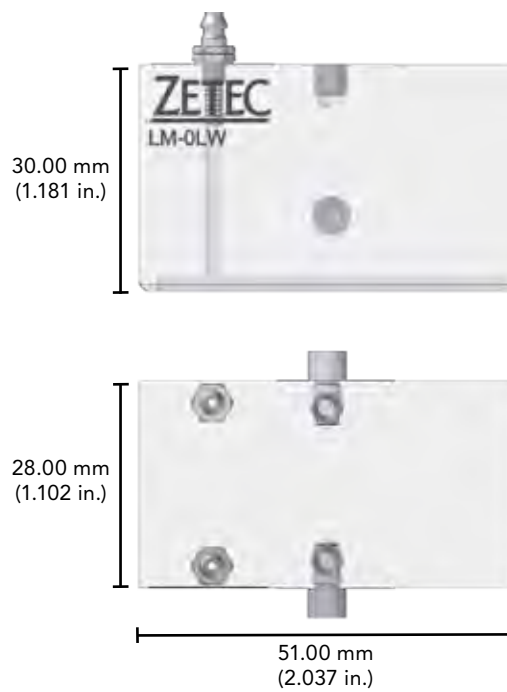

Type L - Medium - 10 MHz (continued)

0° - Acoustic Beam Simulation

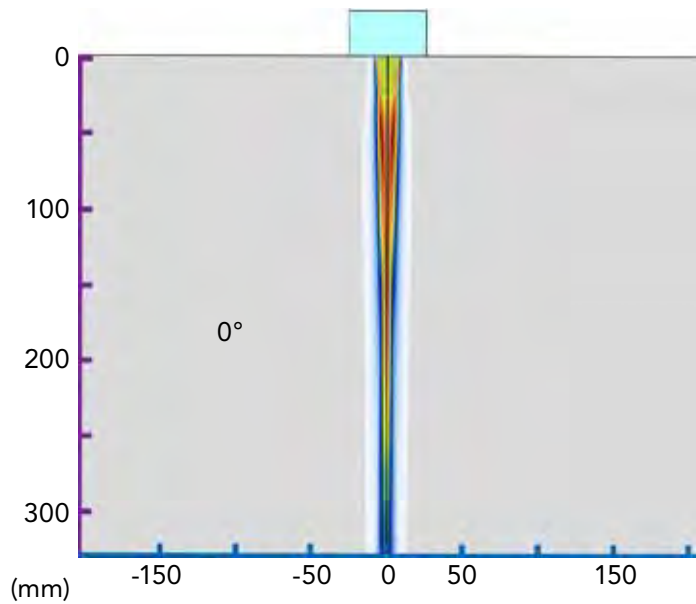

45° - Acoustic Beam Simulation

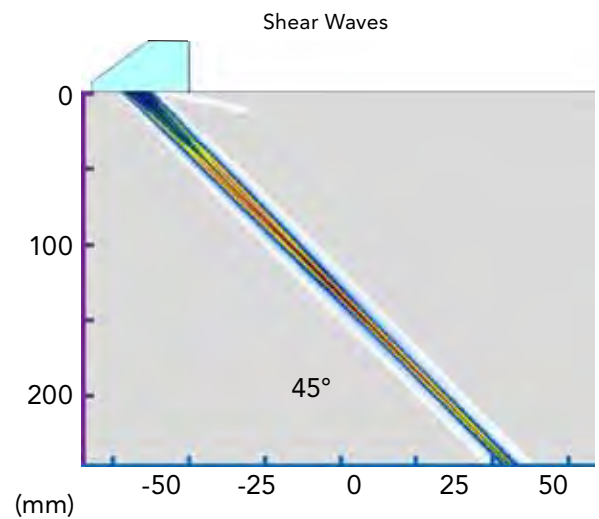
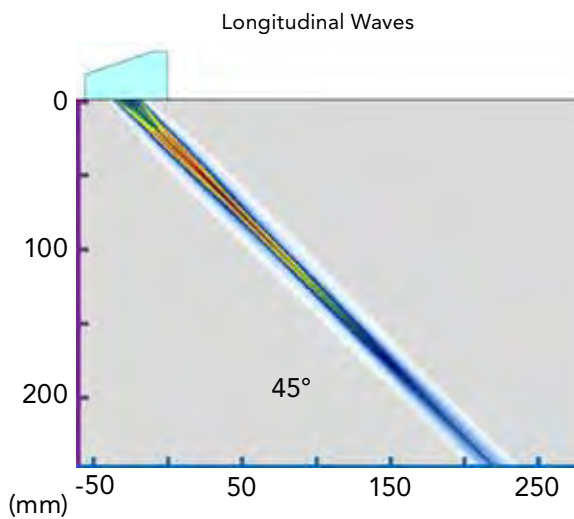

60° - Acoustic Beam Simulation

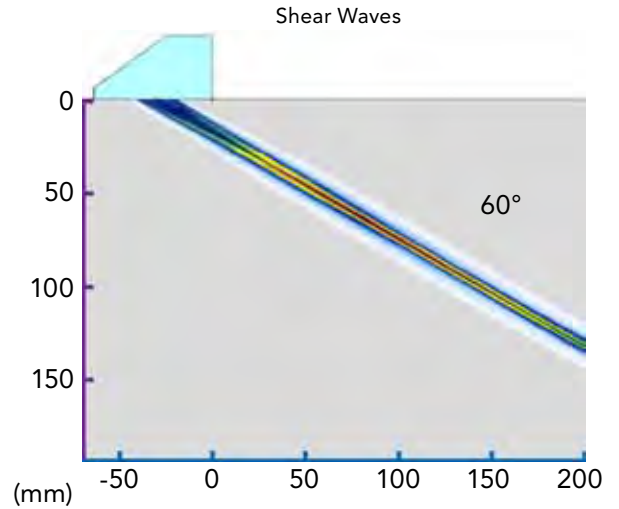
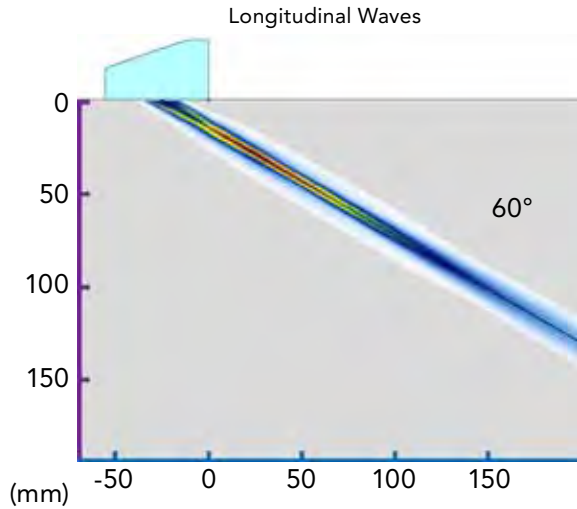

Acoustic Beam Characteristics (from Simulation Data)

Considered Active Aperture	32 elements (17 to 48)				
	0°	45°		60°	
Angle					
Wave Type	LW	LW	SW	LW	SW
Maximum Sound Field Depth	50.50 mm (1.988 in.)	60.00 mm (2.362 in.)	123.00 mm (4.843 in.)	26.00 mm (1.024 in.)	63.00 mm (2.480 in.)
Focal Zone Length	267.00 mm (10.512 in.)	181.74 mm (7.155 in.)	296.28 mm (11.665 in.)	111.88 mm (4.405 in.)	209.12 mm (8.233 in.)
Dimension in the Incident Plane	15.00 mm (0.591 in.)	9.19 mm (0.362 in.)	7.80 mm (0.307 in.)	4.68 mm (0.184 in.)	5.17 mm (0.204 in.)
Dimension in the Perpendicular Plane	8.00 mm (0.315 in.)	4.00 mm (0.157 in.)	6.00 mm (0.236 in.)	4.00 mm (0.157 in.)	4.00 mm (0.157 in.)

Type L - Large - 2.25 MHz

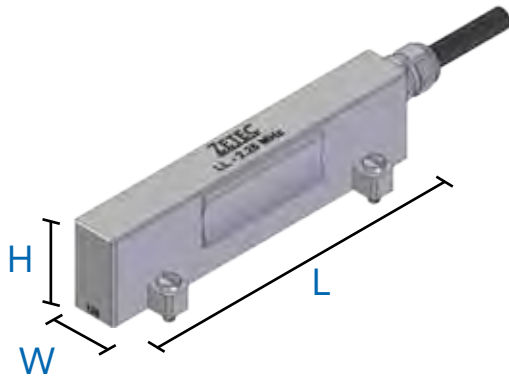

Features & Benefits

- Large aperture for linear scan
- Optimized for thickness measurement and corrosion mapping
- Wave layers with acoustic adaptation to Rexolite®
- Probe cable length: 5 m (16 ft.)
- Two connector types available: ZIRCON and DYNARAY compatible

Probe Specifications and Dimensions

Part ID	Frequency (MHz)	Number of elements (Primary axis)	Primary axis Pitch	Primary axis aperture	Secondary axis aperture	External dimensions		
						L	W	H
LL-2.25MHz-*	2.25	128	0.75 mm (0.030 in.)	96.00 mm (3.780 in.)	10.00 mm (0.394 in.)	100.0 mm (3.937 in.)	28.0 mm (1.102 in.)	25.0 mm (0.984 in.)

(*) : -ZIRCON or -DYNARAY

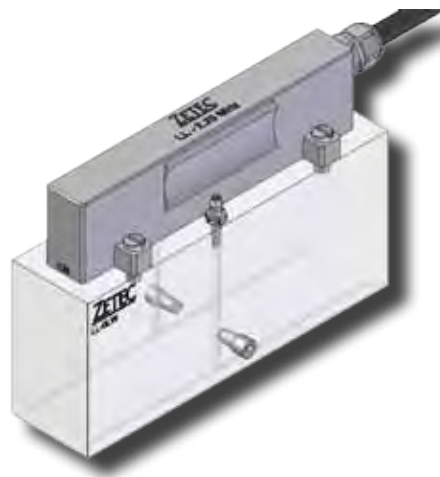

Recommended Wedges

Part ID	Wave type	Name	Nominal angle in steel	Optimized refracted beam angle range (in steel)
LL-0LW	LW	Type L - Large / 0LW	0°	-25° to 25°
LL-55LW	LW	Type L - Large / 55LW	55°	40° to 70°
LL-55SW	SW	Type L - Large / 55SW	55°	40° to 70°

Wedges Dimensions

Type L - Large / 55LW

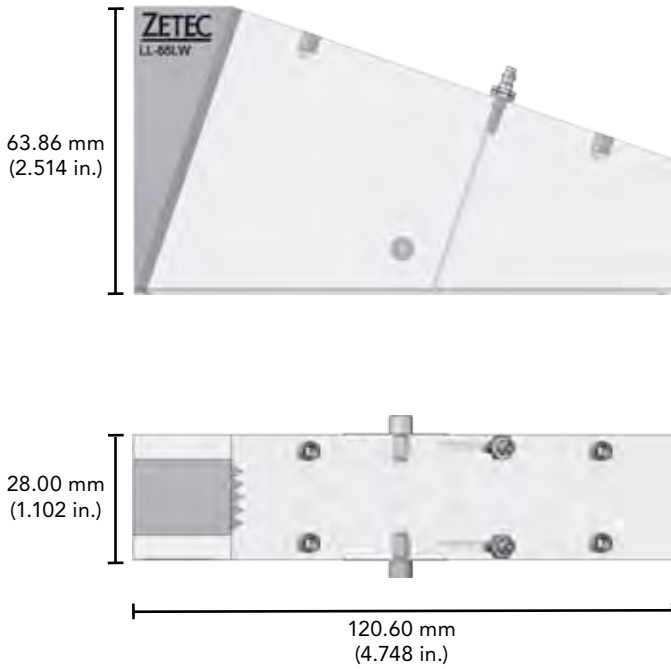

Type L - Large / 55SW

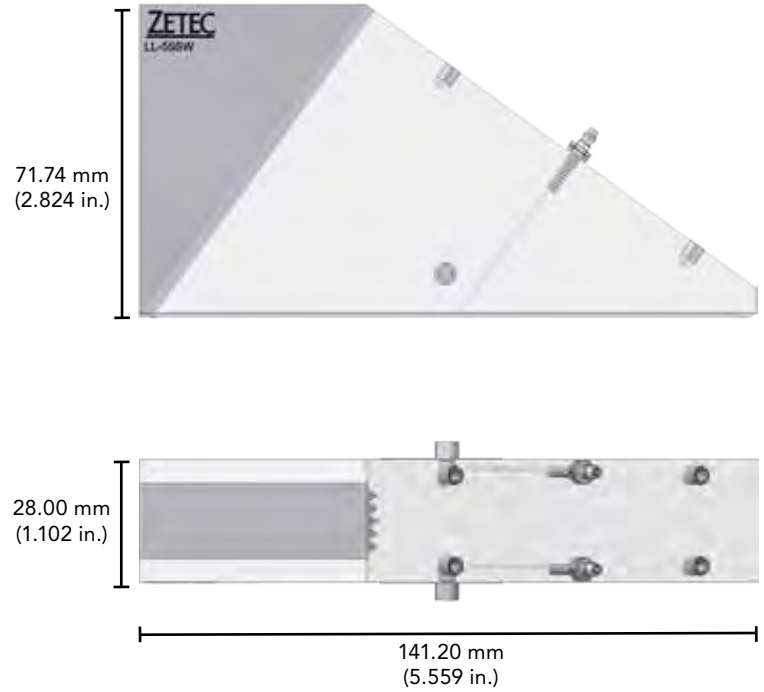

Type L - Large / 0LW

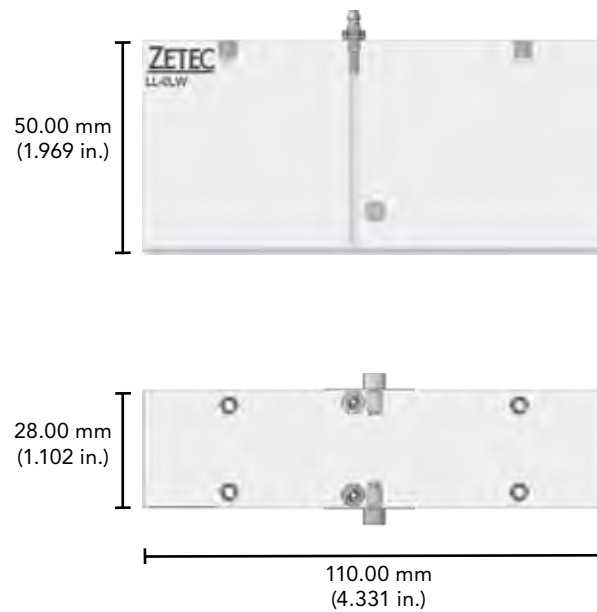

Type L - Large - 2.25 MHz (continued)

0° - Acoustic Beam Simulation

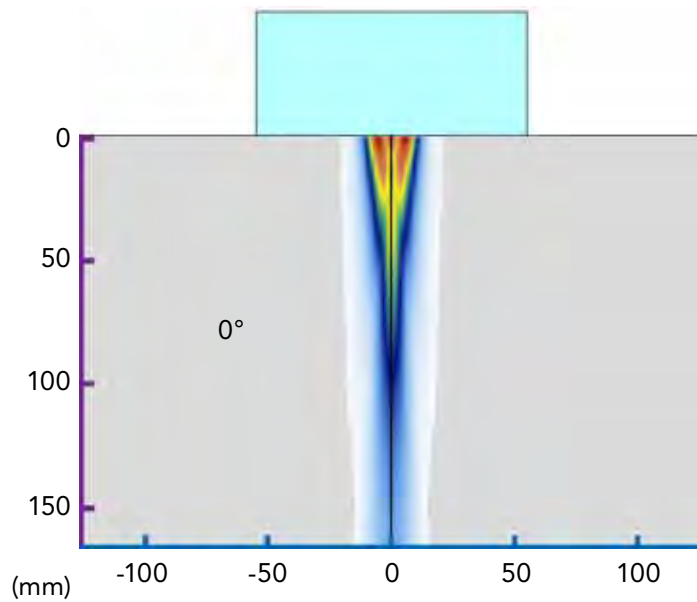

45° - Acoustic Beam Simulation

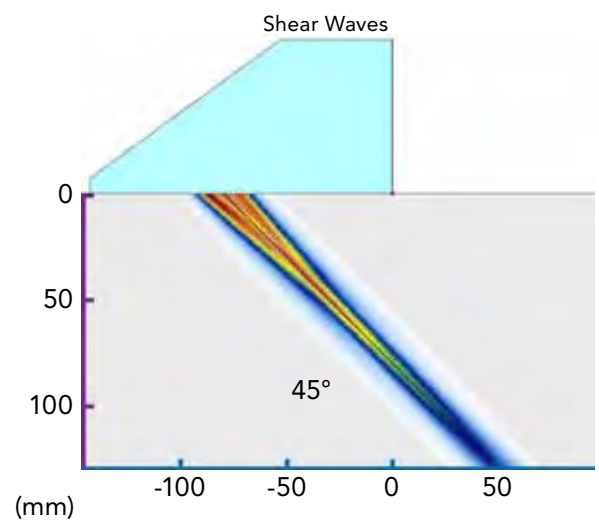
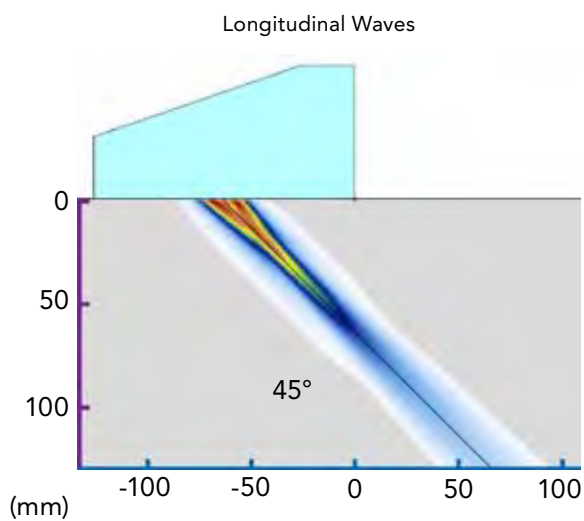

60° - Acoustic Beam Simulation

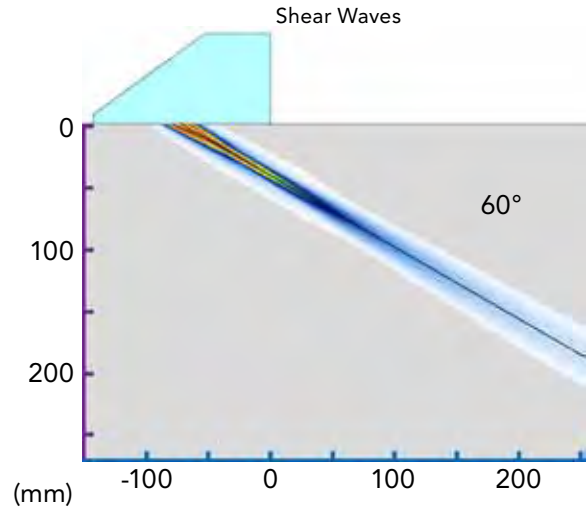
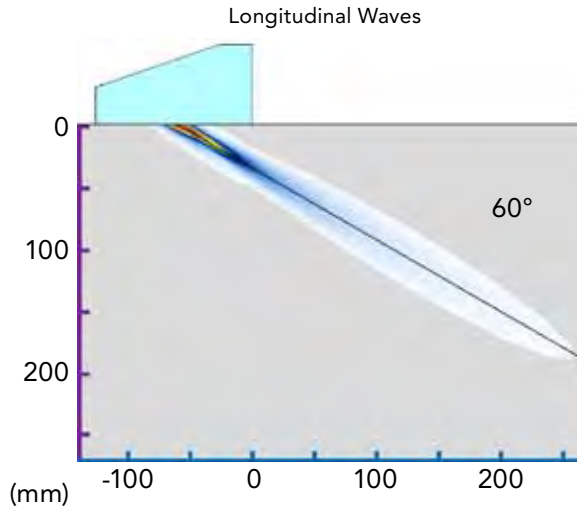

Acoustic Beam Characteristics (from Simulation Data)

Considered Active Aperture	32 elements (49 to 80)				
	0°	45°		60°	
Angle					
Wave Type	LW	LW	SW	LW	SW
Maximum Sound Field Depth	1.00 mm (0.039 in.)	1.00 mm (0.039 in.)	3.00 mm (0.118 in.)	5.50 mm (0.217 in.)	15.00 mm (0.591 in.)
Focal Zone Length	52.50 mm (2.067 in.)	60.55 mm (2.384 in.)	114.59 mm (4.511 in.)	45.68 mm (1.798 in.)	100.05 mm (3.939 in.)
Dimension in the Incident Plane	18.00 mm (0.709 in.)	12.57 mm (0.495 in.)	14.12 mm (0.556 in.)	8.32 mm (0.323 in.)	10.84 mm (0.428 in.)
Dimension in the Perpendicular Plane	5.00 mm (0.197 in.)	9.00 mm (0.354 in.)	8.00 mm (0.315 in.)	7.00 mm (0.276 in.)	9.00 mm (0.354 in.)

Type L - Large - 3.5 MHz

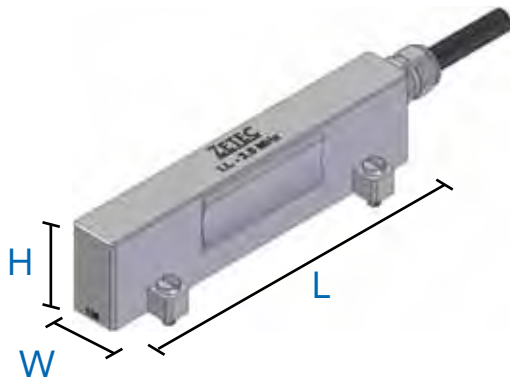

Features & Benefits

- Large aperture for linear scan
- Optimized for thickness measurement and corrosion mapping
- Wave layers with acoustic adaptation to Rexolite®
- Probe cable length: 5 m (16 ft.)
- Two connector types available: ZIRCON and DYNARAY compatible

Probe Specifications and Dimensions

Part ID	Frequency (MHz)	Number of elements (Primary axis)	Primary axis Pitch	Primary axis aperture	Secondary axis aperture	External dimensions		
						L	W	H
LL-3.5MHz-*	3.5	128	0.75 mm (0.030 in.)	96.00 mm (3.780 in.)	10.00 mm (0.394 in.)	100.0 mm (3.937 in.)	28.0 mm (1.102 in.)	25.0 mm (0.984 in.)

(*) : -ZIRCON or -DYNARAY

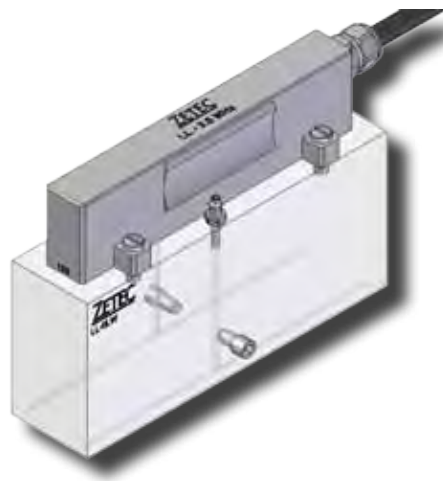

Recommended Wedges

Part ID	Wave type	Name	Nominal angle in steel	Optimized refracted beam angle range (in steel)
LL-0LW	LW	Type L - Large / 0LW	0°	-25° to 25°
LL-55LW	LW	Type L - Large / 55LW	55°	40° to 70°
LL-55SW	SW	Type L - Large / 55SW	55°	40° to 70°

Wedges Dimensions

Type L - Large / 55LW

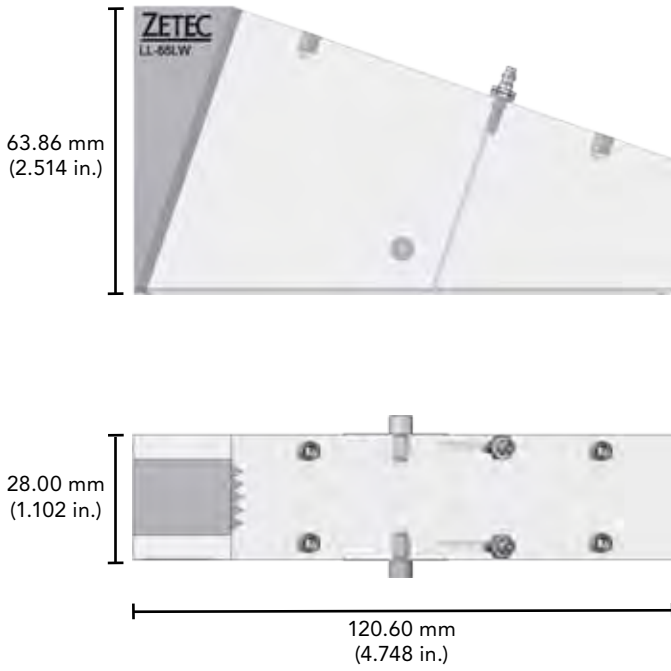

Type L - Large / 55SW

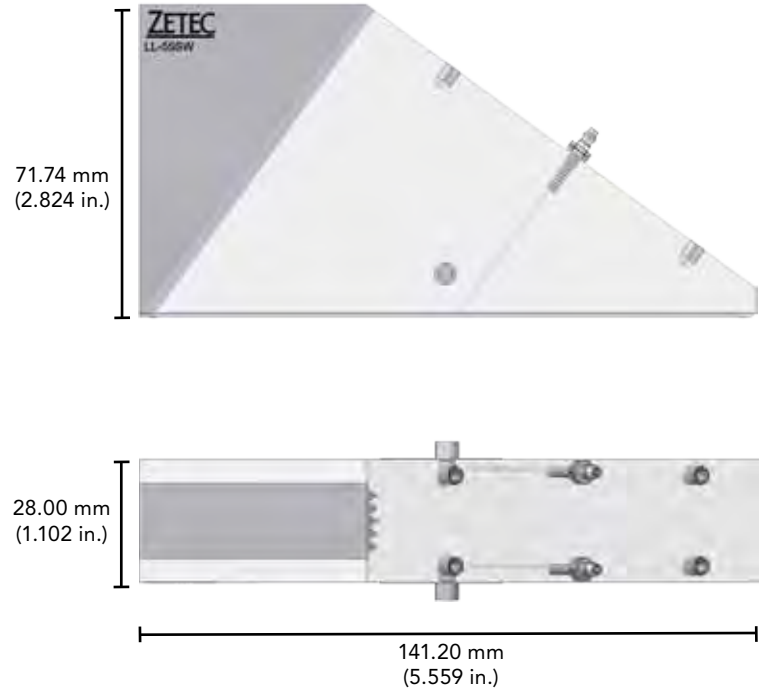

Type L - Large / 0LW

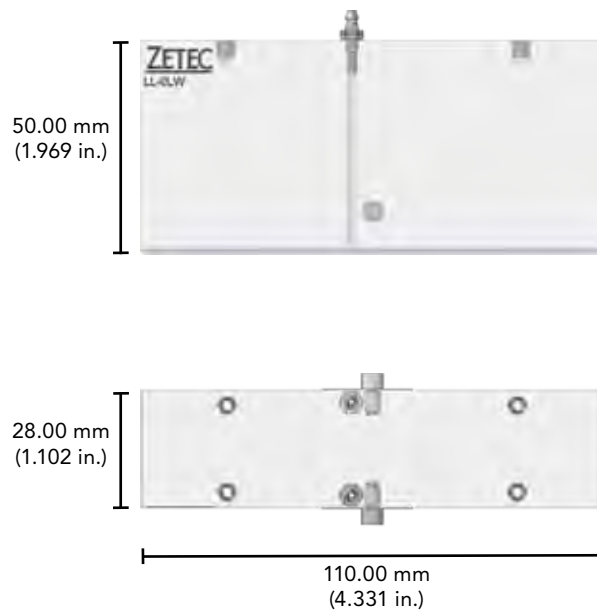

Type L - Large - 3.5 MHz (continued)

0° - Acoustic Beam Simulation

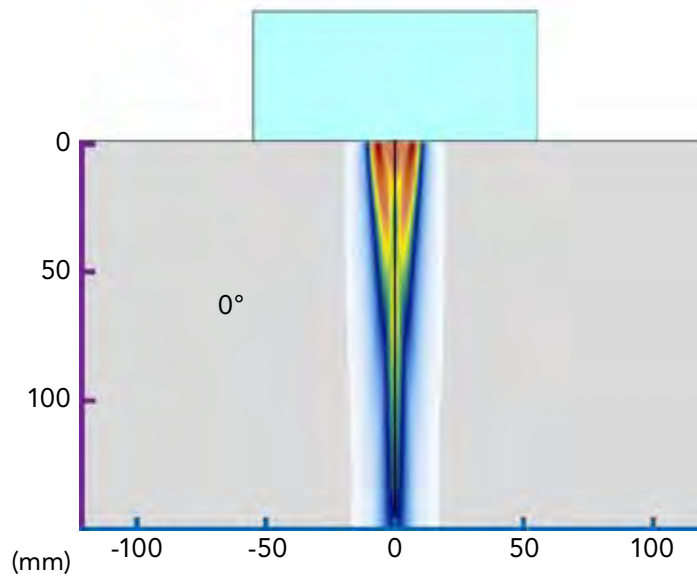

45° - Acoustic Beam Simulation

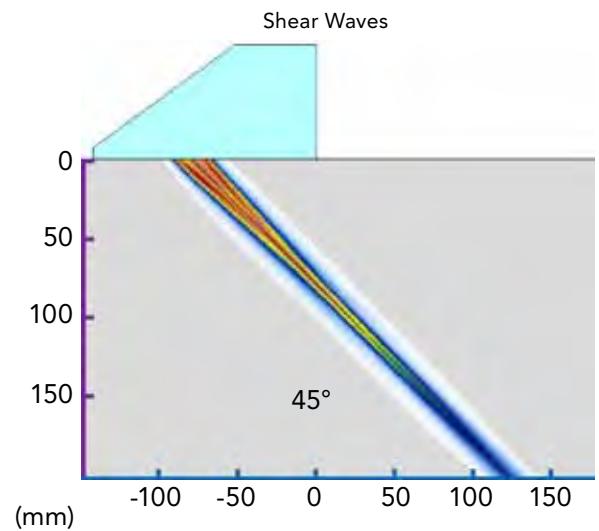
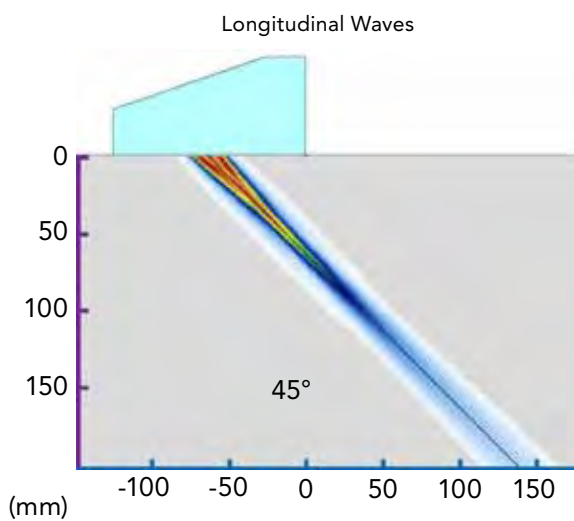

60° - Acoustic Beam Simulation

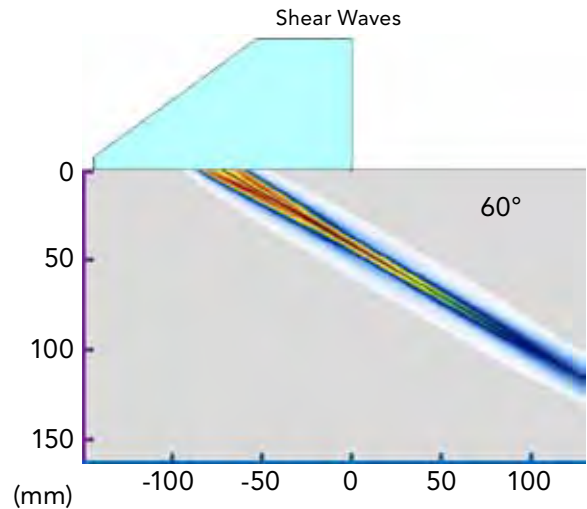
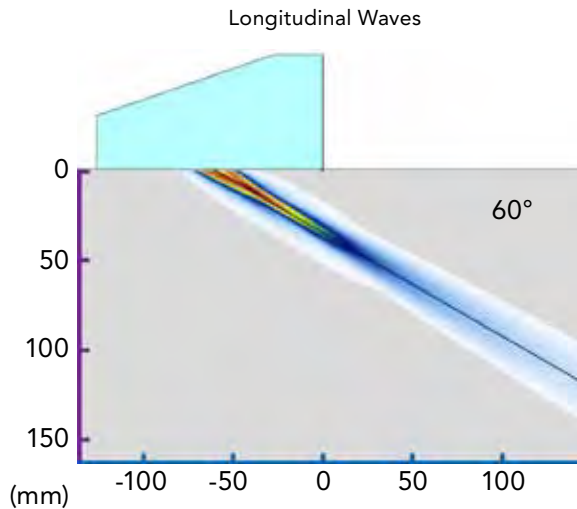

Acoustic Beam Characteristics (from Simulation Data)

Considered Active Aperture	32 elements (49 to 80)				
	0°	45°		60°	
Angle					
Wave Type	LW	LW	SW	LW	SW
Maximum Sound Field Depth	1.50 mm (0.059 in.)	6.00 mm (0.236 in.)	8.00 mm (0.315 in.)	10.50 mm (0.413 in.)	28.00 mm (1.102 in.)
Focal Zone Length	84.00 mm (3.307 in.)	89.14 mm (3.509 in.)	179.62 mm (7.072 in.)	67.62 mm (2.662 in.)	147.97 mm (5.826 in.)
Dimension in the Incident Plane	18.00 mm (0.709 in.)	13.34 mm (0.525 in.)	14.15 mm (0.557 in.)	8.90 mm (0.350 in.)	11.05 mm (0.435 in.)
Dimension in the Perpendicular Plane	4.00 mm (0.157 in.)	8.00 mm (0.315 in.)	8.00 mm (0.315 in.)	6.00 mm (0.236 in.)	8.00 mm (0.315 in.)

Type L - Large - 5 MHz

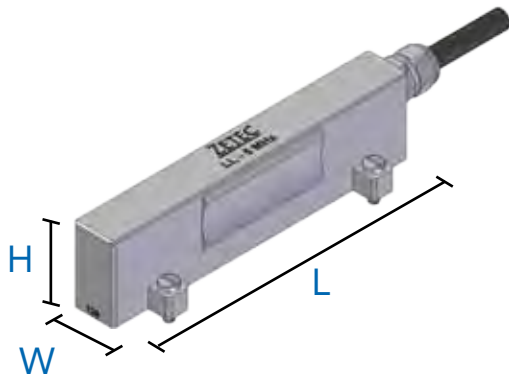

Features & Benefits

- Large aperture for linear scan
- Optimized for thickness measurement and corrosion mapping
- Wave layers with acoustic adaptation to Rexolite®
- Probe cable length: 5 m (16 ft.)
- Two connector types available: ZIRCON and DYNARAY compatible

Probe Specifications and Dimensions

Part ID	Frequency (MHz)	Number of elements (Primary axis)	Primary axis Pitch	Primary axis aperture	Secondary axis aperture	External dimensions		
						L	W	H
LL-5MHz-*	5.0	128	0.75 mm (0.030 in.)	96.00 mm (3.780 in.)	10.00 mm (0.394 in.)	100.0 mm (3.937 in.)	28.0 mm (1.102 in.)	25.0 mm (0.984 in.)

(*) : -ZIRCON or -DYNARAY

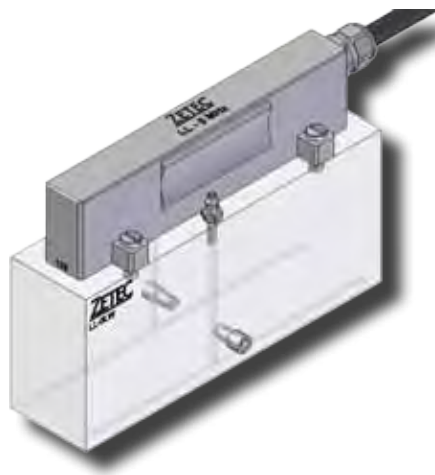

Recommended Wedges

Part ID	Wave type	Name	Nominal angle in steel	Optimized refracted beam angle range (in steel)
LL-0LW	LW	Type L - Large / 0LW	0°	-25° to 25°
LL-55LW	LW	Type L - Large / 55LW	55°	40° to 70°
LL-55SW	SW	Type L - Large / 55SW	55°	40° to 70°

Wedges Dimensions

Type L - Large / 55LW

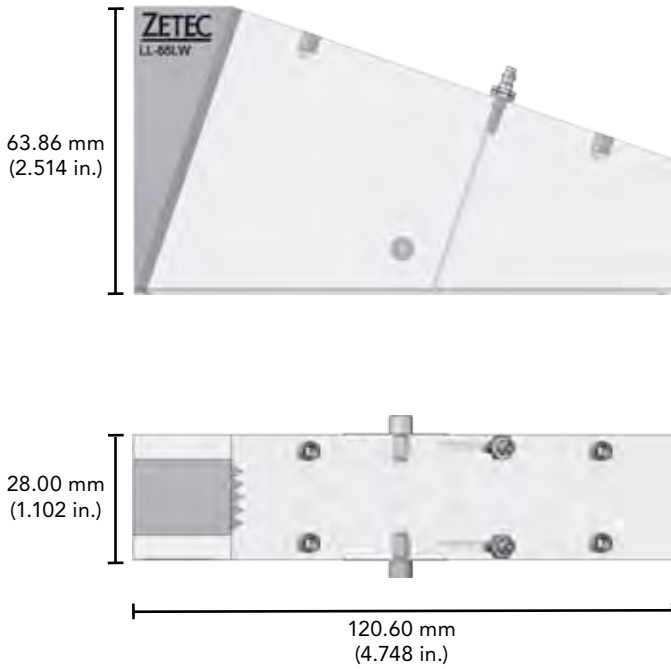

Type L - Large / 55SW

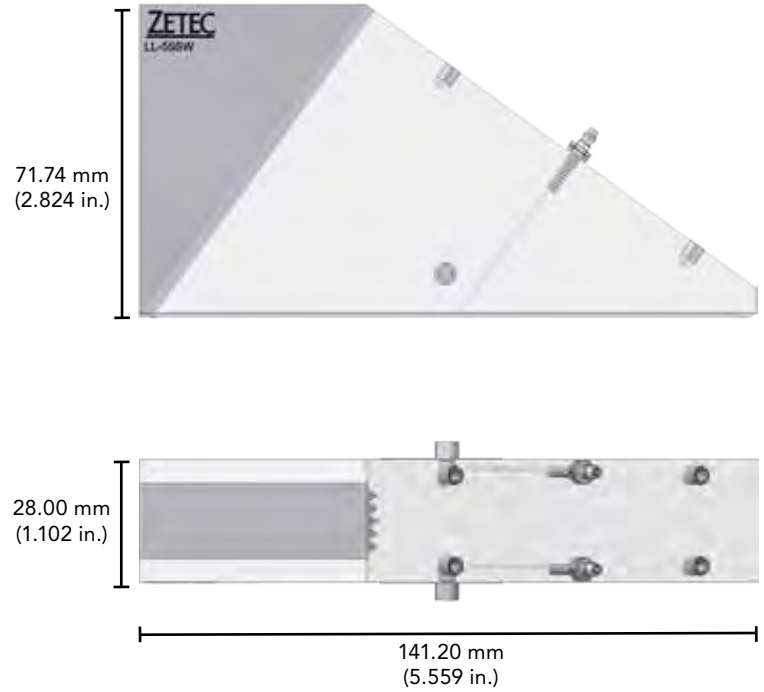

Type L - Large / 0LW

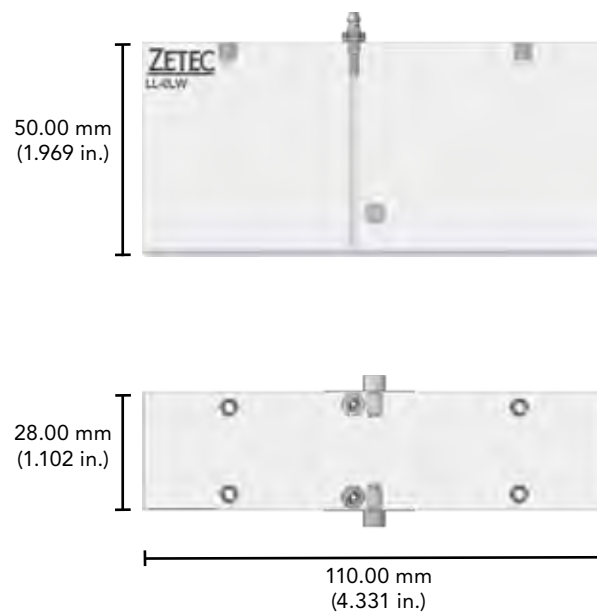

Type L - Large - 5 MHz (continued)

0° - Acoustic Beam Simulation

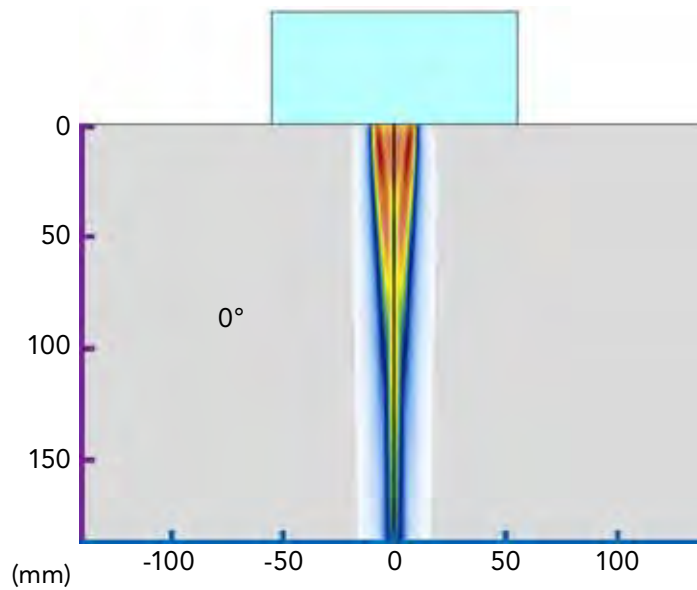

45° - Acoustic Beam Simulation

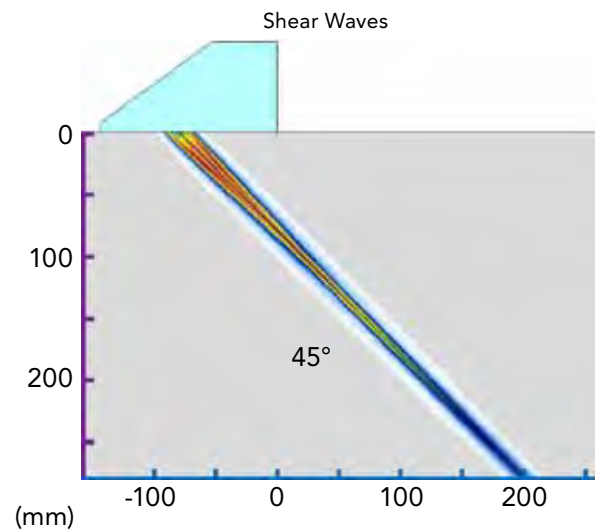
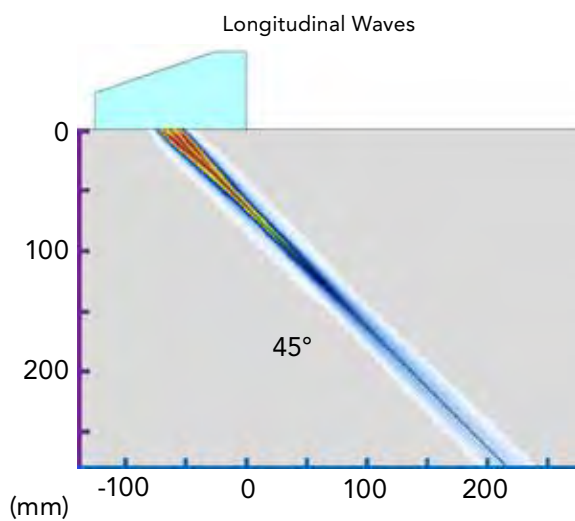

60° - Acoustic Beam Simulation

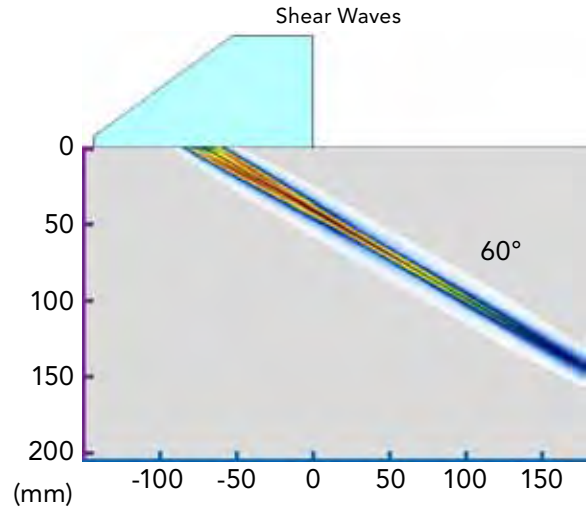
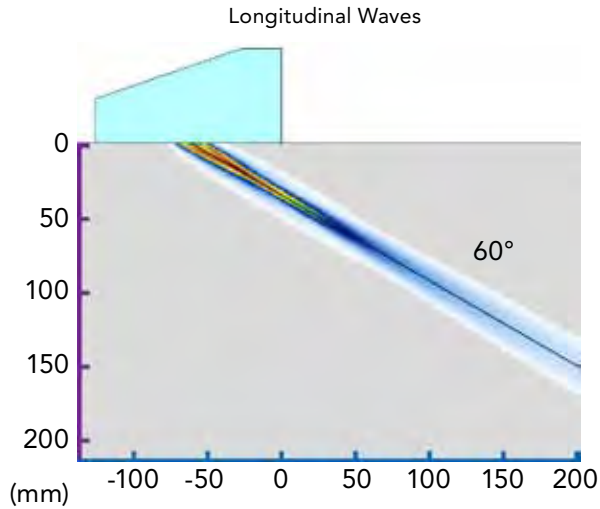

Acoustic Beam Characteristics (from Simulation Data)

Considered Active Aperture	32 elements (49 to 80)				
	0°	45°		60°	
Angle					
Wave Type	LW	LW	SW	LW	SW
Maximum Sound Field Depth	10.50 mm (0.413 in.)	11.00 mm (0.433 in.)	22.00 mm (0.866 in.)	17.00 mm (0.669 in.)	41.00 mm (1.614 in.)
Focal Zone Length	143.50 mm (5.650 in.)	126.60 mm (4.984 in.)	260.22 mm (10.245 in.)	91.18 mm (3.590 in.)	200.43 mm (7.891 in.)
Dimension in the Incident Plane	18.00 mm (0.709 in.)	12.75 mm (0.502 in.)	14.16 mm (0.557 in.)	8.51 mm (0.335 in.)	10.57 mm (0.416 in.)
Dimension in the Perpendicular Plane	6.00 mm (0.236 in.)	6.00 mm (0.236 in.)	8.00 mm (0.315 in.)	6.00 mm (0.236 in.)	6.00 mm (0.236 in.)

Type L - Large - 10 MHz

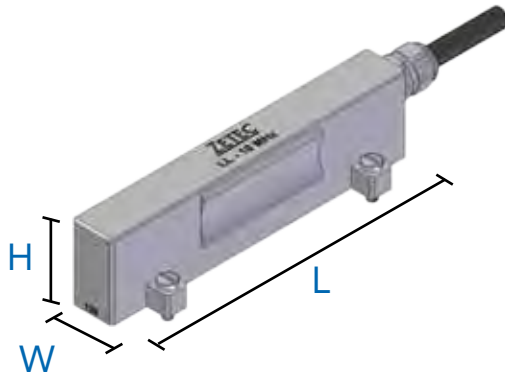

Features & Benefits

- Large aperture for linear scan
- Optimized for thickness measurement and corrosion mapping
- Wave layers with acoustic adaptation to Rexolite®
- Probe cable length: 5 m (16 ft.)
- Two connector types available: ZIRCON and DYNARAY compatible

Probe Specifications and Dimensions

Part ID	Frequency (MHz)	Number of elements (Primary axis)	Primary axis Pitch	Primary axis aperture	Secondary axis aperture	External dimensions		
						L	W	H
LL-10MHz-*	10.0	128	0.75 mm (0.030 in.)	96.00 mm (3.780 in.)	10.00 mm (0.394 in.)	100.0 mm (3.937 in.)	28.0 mm (1.102 in.)	25.0 mm (0.984 in.)

(*) : -ZIRCON or -DYNARAY

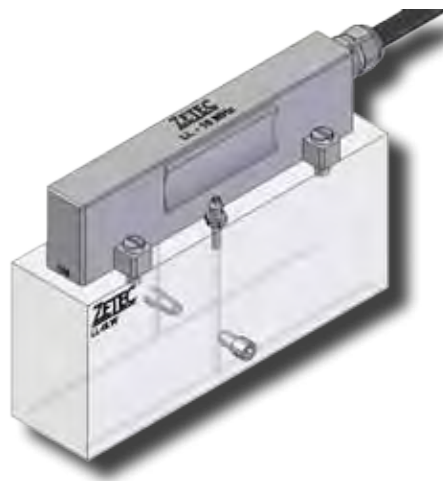

Recommended Wedges

Part ID	Wave type	Name	Nominal angle in steel	Optimized refracted beam angle range (in steel)
LL-0LW	LW	Type L - Large / 0LW	0°	-25° to 25°
LL-55LW	LW	Type L - Large / 55LW	55°	40° to 70°
LL-55SW	SW	Type L - Large / 55SW	55°	40° to 70°

Wedges Dimensions

Type L - Large / 55LW

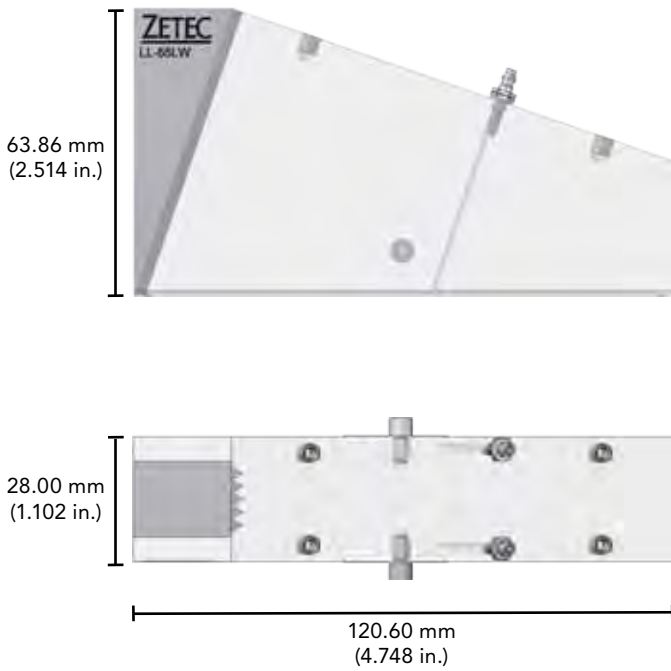

Type L - Large / 55SW

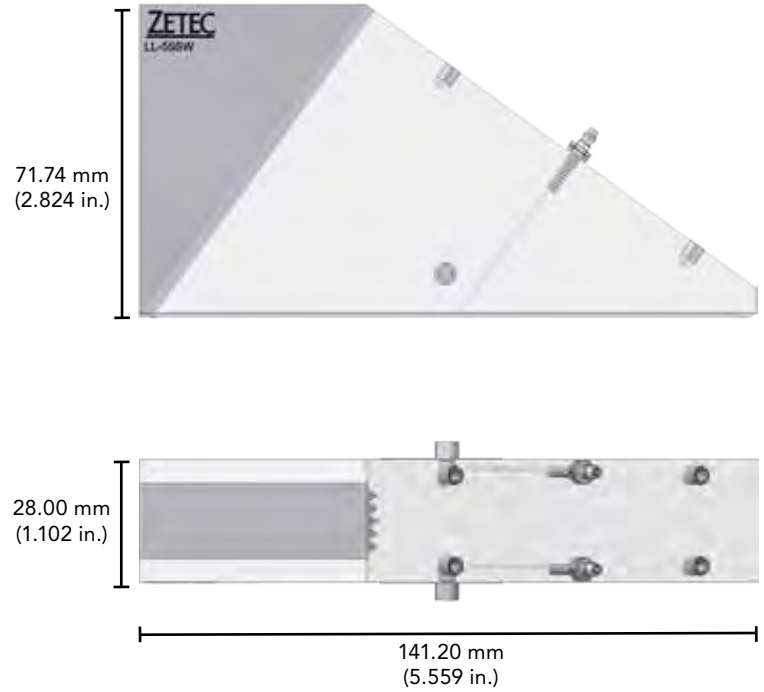

Type L - Large / 0LW

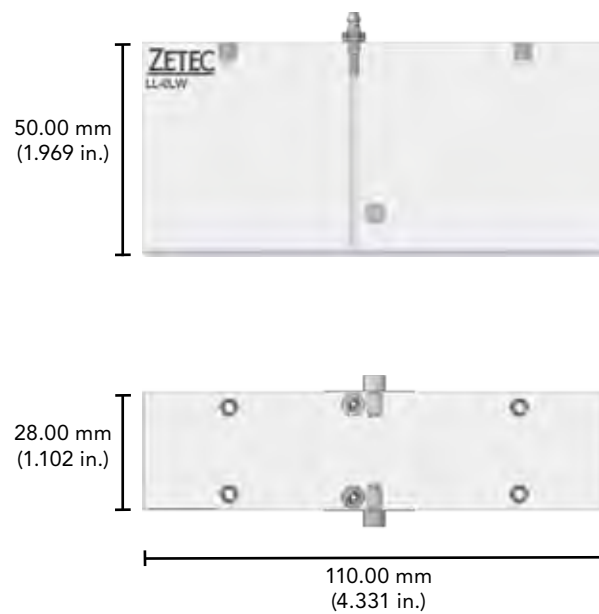

Type L - Large - 10 MHz (continued)

0° - Acoustic Beam Simulation

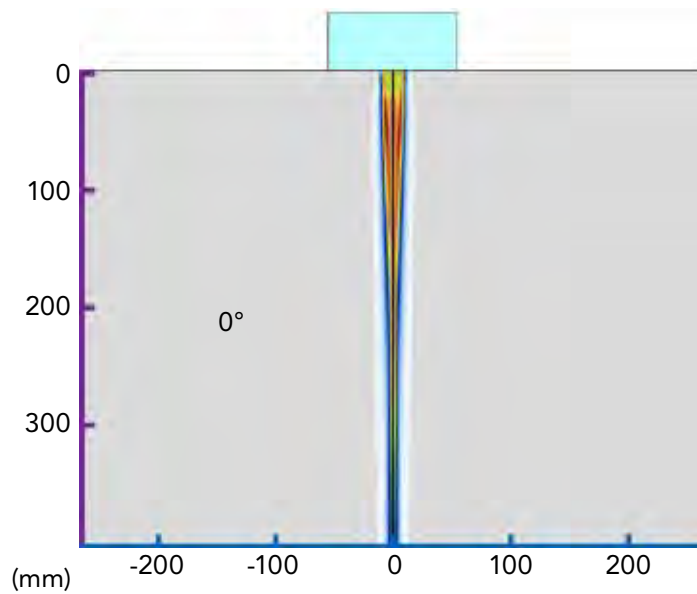

45° - Acoustic Beam Simulation

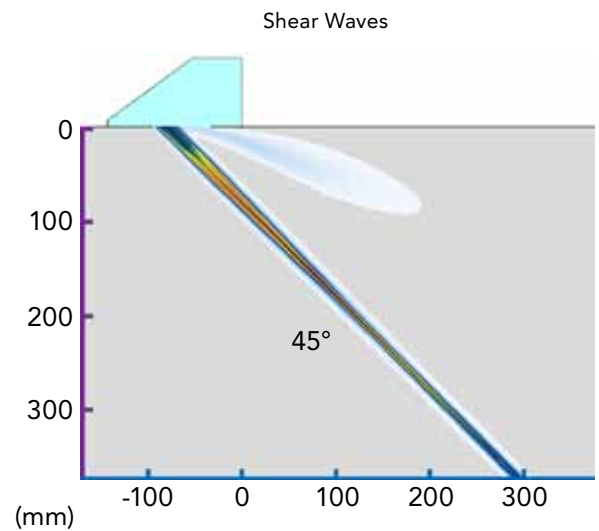
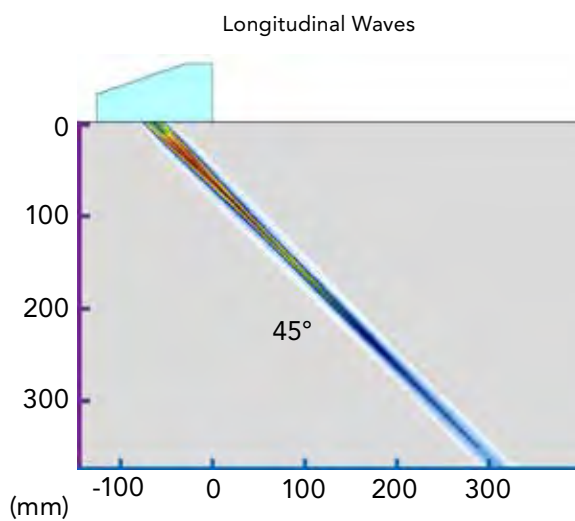

60° - Acoustic Beam Simulation

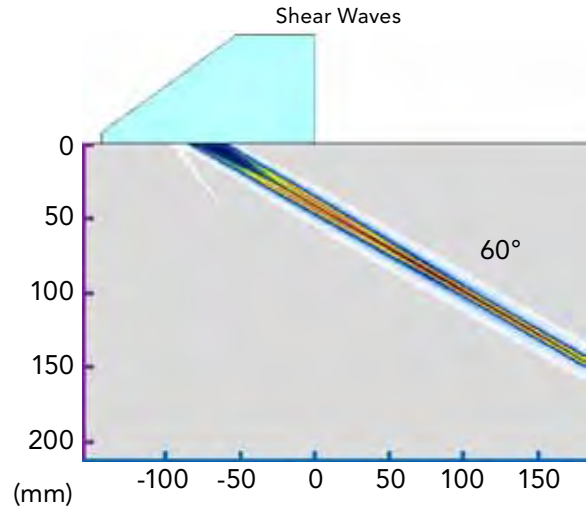
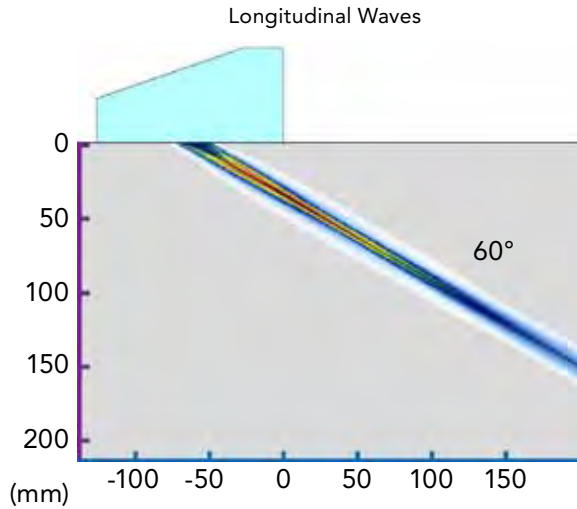

Acoustic Beam Characteristics (from Simulation Data)

Considered Active Aperture	32 elements (49 to 80)				
	0°	45°		60°	
Angle					
Wave Type	LW	LW	SW	LW	SW
Maximum Sound Field Depth	40.00 mm (1.575 in.)	79.00 mm (3.110 in.)	148.00 mm (5.827 in.)	34.00 mm (1.339 in.)	81.00 mm (3.189 in.)
Focal Zone Length	336.00 mm (13.228 in.)	258.10 mm (10.161 in.)	412.96 mm (16.258 in.)	147.22 mm (5.796 in.)	306.23 mm (12.056 in.)
Dimension in the Incident Plane	19.00 mm (0.748 in.)	12.73 mm (0.501 in.)	11.36 mm (0.447 in.)	7.22 mm (0.284 in.)	8.46 mm (0.333 in.)
Dimension in the Perpendicular Plane	9.00 mm (0.354 in.)	6.00 mm (0.236 in.)	6.00 mm (0.236 in.)	4.00 mm (0.157 in.)	6.00 mm (0.236 in.)

Wedges for Azimuthal Scanning

For Type A - Small



Small / 55SW



Small / 55LW

Part ID	Type	Wedge Angle	Length	Width	Height	H1	X1	Length - X1	Y1
AS-55SW	Type A - Small / 55SW	36.0°	16.30 mm (0.642 in.)	30.00 mm (1.181 in.)	10.17 mm (0.400 in.)	5.00 mm (0.197 in.)	1.78 mm (0.070 in.)	14.52 mm (0.572 in.)	15.00 mm (0.591 in.)
AS-55LW	Type A - Small / 55LW	19.0°	17.20 mm (0.677 in.)	30.00 mm (1.181 in.)	16.86 mm (0.642 in.)	14.00 mm (0.551 in.)	3.03 mm (0.119 in.)	14.17 mm (0.558 in.)	15.00 mm (0.591 in.)

For Type A - Medium



Medium / 55SW



Medium / 55LW

Part ID	Type	Wedge Angle	Length	Width	Height	H1	X1	Length - X1	Y1
AM-55SW	Type A - Medium / 55SW	36.0°	23.50 mm (0.925 in.)	30.00 mm (1.181 in.)	12.48 mm (0.491 in.)	4.00 mm (0.157 in.)	2.73 mm (0.107 in.)	20.77 mm (0.818 in.)	15.00 mm (0.591 in.)
AM-55LW	Type A - Medium / 55LW	19.0°	25.00 mm (0.984 in.)	30.00 mm (1.181 in.)	23.26 mm (0.916 in.)	18.50 mm (0.728 in.)	3.19 mm (0.126 in.)	21.81 mm (0.859 in.)	15.00 mm (0.591 in.)

For Type A - Large



Large / 55SW



Large / 55LW

Part ID	Type	Wedge Angle	Length	Width	Height	H1	X1	Length - X1	Y1
AL-55SW	Type A - Large / 55SW	36.0°	38.20 mm (1.504 in.)	33.00 mm (1.299 in.)	21.98 mm (0.865 in.)	8.00 mm (0.315 in.)	2.99 mm (0.118 in.)	35.21 mm (1.386 in.)	16.50 mm (0.650 in.)
AL-55LW	Type A - Large / 55LW	19.0°	41.40 mm (1.630 in.)	33.00 mm (1.299 in.)	41.17 mm (1.621 in.)	33.00 mm (1.299 in.)	3.50 mm (0.138 in.)	37.90 mm (1.492 in.)	16.50 mm (0.650 in.)

For Type A - X-Large



X-Large / 55SW



X-Large / 55LW

Part ID	Type	Wedge Angle	Length	Width	Height	H1	X1	Length - X1	Y1
AXL-55SW	Type A - Xlarge / 55SW	36.0°	58.70 mm (2.311 in.)	38.00 mm (1.496 in.)	33.77 mm (1.330 in.)	11.00 mm (0.433 in.)	2.83 mm (0.111 in.)	55.87 mm (2.120 in.)	19.00 mm (0.748 in.)
AXL-55LW	Type A - Xlarge / 55LW	19.0°	62.40 mm (2.457 in.)	38.00 mm (1.496 in.)	65.57 mm (2.581 in.)	53.00 mm (2.087 in.)	3.31 mm (0.130 in.)	59.09 mm (2.326 in.)	19.00 mm (0.748 in.)

Wedges for Linear Scanning

For Type L - Medium



Medium / 0LW



Medium / 55SW



Medium / 55LW

Part ID	Type	Wedge Angle	Length	Width	Height	H1	X1	Length - X1	Y1
LM-0LW	Type L - Medium / 0LW	0°	51.00 mm (2.037 in.)	28.00 mm (1.102 in.)	30.00 mm (1.181 in.)	30.00 mm (1.181 in.)	6.60 mm (0.260 in.)	44.40 mm (1.748 in.)	14.00 mm (0.551 in.)
LM-55SW	Type L - Medium / 55SW	36.0°	63.80 mm (2.512 in.)	28.00 mm (1.102 in.)	34.19 mm (1.346 in.)	8.00 mm (0.315 in.)	2.91 mm (0.115 in.)	60.89 mm (2.397 in.)	14.00 mm (0.551 in.)
LM-55LW	Type L - Medium / 55LW	19.0°	57.70 mm (2.272 in.)	28.00 mm (1.102 in.)	39.97 mm (1.574 in.)	26.00 mm (1.024 in.)	3.40 mm (0.134 in.)	54.30 mm (2.138 in.)	14.00 mm (0.551 in.)

For Type L - Large



Large / 0LW



Large / 55SW



Large / 55LW

Part ID	Type	Wedge Angle	Length	Width	Height	H1	X1	Length - X1	Y1
LL-0LW	Type L - Large / 0LW	0°	110.0 mm (4.331 in.)	28.00 mm (1.102 in.)	50.00 mm (1.969 in.)	50.00 mm (1.969 in.)	7.38 mm (0.291 in.)	102.62 mm (4.040 in.)	14.00 mm (0.551 in.)
LL-55SW	Type L - Large / 55SW	36.0°	141.2 mm (5.559 in.)	28.00 mm (1.102 in.)	71.74 mm (2.824 in.)	9.00 mm (0.354 in.)	2.73 mm (0.107 in.)	138.47 mm (5.452 in.)	14.00 mm (0.551 in.)
LL-55LW	Type L - Large / 55LW	19.0°	120.6 mm (4.748 in.)	28.00 mm (1.102 in.)	63.86 mm (2.514 in.)	31.00 mm (1.220 in.)	3.19 mm (0.126 in.)	117.41 mm (4.622 in.)	14.00 mm (0.551 in.)

Adapters, Splitters and Other Accessories

ZETEC offers a series of connection adapters which allows operation of its standard PA probes on different hardware platforms or of other PA probes on ZETEC's equipment. In order to allow simultaneous operation of multiple PA probes, we also offer a series of splitter cables.

Should you need special connection solutions, don't hesitate to contact us for any custom design.

Adapter boxes



ADPBOX-ZIRCON-DYNARAY



ADPBOX-ZIRCON-OMNI



ADPBOX-DYNARAY-ZIRCON



ADPBOX-DYNARAY-OMNI

Part ID	Description
ADPBOX-ZIRCON-DYNARAY	Adapter Box - Connect one DYNARAY compatible PA probe connector (Hypertronics) to the ZIRCON (ZIRCON male connector to DYNARAY female connector, 128 connections)
ADPBOX-ZIRCON-OMNI	Adapter Box - Connect one Omni-type PA probe connector to the ZIRCON (ZIRCON male connector to Omni-type female connector, 128 connections)
ADPBOX-DYNARAY-ZIRCON	Adapter Box - Connect one ZIRCON compatible PA probe connector to the DYNARAY (Hypertronics) (DYNARAY male connector to ZIRCON female connector, 128 connections)
ADPBOX-DYNARAY-OMNI	Adapter Box - Connect one OMNI-type PA probe connector to the DYNARAY (Hypertronics) (DYNARAY male connector to OMNI-type female connector, 128 connections)

Splitters



SPLTBOX-ZIRCON-2ZIRCON64



SPLTCBL-ZIRCON-2DYNARAY64

Part ID	Description
SPLTBOX-ZIRCON-2ZIRCON64	Splitter Box - Connect simultaneously 2 ZIRCON compatible PA probes to the ZIRCON (ZIRCON male connector to 2 ZIRCON female connectors, 1-64 and 65-128)
SPLTCBL-ZIRCON-2DYNARAY64	Splitter Cable - Connect simultaneously 2 DYNARAY compatible PA probes (Hypertronics) to the ZIRCON (ZIRCON male connector to 2 DYNARAY female connectors, 1-64 and 65-128)

ZETEC also offers accessories to use with your phased array probes and wedges. This includes handheld encoders and scanners for position feedback when acquiring your UT signals.

For generic or custom scanner designs, ZETEC can provide you with scanning mechanisms that will improve your examinations. Don't hesitate to contact us for any scanning needs.

Handheld Encoder

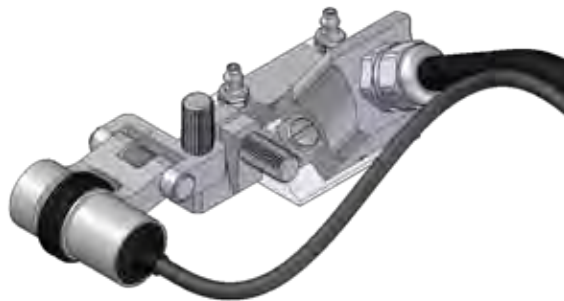

ACC-ZIRCON-ENC-5M-DE15

Part ID	Description
ACC-ZIRCON-ENC-5M-DE15	Mini encoder - 5 m cable - waterproof - DE15 connector compatible with ZIRCON systems - includes bracket kit to attach on Zetec wedges



ZETEC holds *ISO 9001:2008*
and *ISO/IEC 17025:2005*
certifications

ZETEC[®]

To order, contact us:

info@zetec.com

Toll free: 800.643.1771

P: 418.266.3020

F: 418.263.3742

875 boul. Charest Ouest, Suite 100
Québec, Qc, CANADA G1N 2C9

GE
Measurement & Control

Standard Phased Array Probes and Accessories

www.UTprobes.com



GE imagination at work

Table of contents

Introduction.....	3
Definitions	4
Connector Options	5
General Use Probes.....	6
Wedges-Delay Lines-Wear Caps for General Use Probes	7
Corrosion Probes	8
Accessories for Corrosion Probes.....	9
MSWS Probes.....	10
Wedges for MSWS Probes.....	11
Scribeline Probes	12
Wedges for Scribeline Probes.....	13
Hardwater Probes.....	14
Accessories for Hardwater Probes.....	15
Immersion Probes.....	16
High Resolution Probes.....	17
RotoArray	18
Accessories for RotoArray Probes	19
Integral Wedge Probes.....	20
Certificates of Conformity.....	21
Regional Offices	28

GE's Inspection Technologies business manufactures a wide variety of phased array transducers for use with Phasor XS and other ultrasonic flaw detectors.

33 standard phased array transducers cover a broad application spectrum and are stocked and available with short delivery times. All these probes offer three connector options and are manufactured to GE's high quality standards.

More information on our full range of phased array transducers is available at www.UTprobes.com



Definitions

1. **KERF:** Spacing between elements.
2. **PITCH:** Element size plus kerf.
3. **PASSIVE WIDTH / Elevation:** Size of element on linear array in non steering axis.
4. **LINEAR ARRAY:** Array with the ability to steer in one axis and fixed on the opposite axis or scan in one axis.
5. **TEST MATERIAL:** The common name of the material being tested (ex. carbon steel).
6. **ACOUSTIC VELOCITY:** The wave speed of the desired wave mode in the material (preferred units = inches x 106 per second). Please specify the acoustic velocity if it is known. Otherwise, GE will use the general published velocity for the material.
7. **COUPLANT MEDIUM:** What couplant material will be used between the probe and the test specimen (wedge, water, coolant, etc... also include wedge thickness or water patch used).
8. **VIRTUAL PROBE:** Size of the element when fired (example: linear array 1 mm pitch x 10 mm width fired with 10 elements would have a virtual probe size of 10 mm x 10 mm).
Note: Array near field and focus ability will be determined by the Virtual Probe size used during the test.
9. **LINE FOCUS:** Array will focus in a line (flat linear array when focused at a certain depth will give a line focus, similar to a cylindrical focus single element probe).
10. **SPOT FOCUS:** Array will focus at a point.

Linear Array

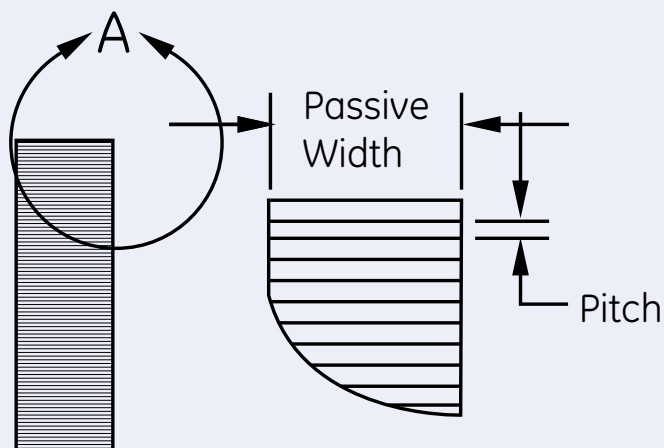

Connector Options

Almost every probe in this catalog can be delivered with three connector options. The part numbers for each connector option are directly listed on product pages.

Phasor connector



Omniscan® connector



Hypertronics connector



As an example, if 115-120-001 part number from the table below is ordered, the probe will be delivered with Hypertronics connector with a short lead time.

Part number Phasor	Part number Hypertronics	Part number Omniscan®	Aperture (mm)	Frequency (MHz)	Element Count	Pitch (mm)	Elevation (mm)	Cable (m)	Case Style	A (mm)	B (mm)	C (mm)	D (mm)
115-100-001	115-120-001	115-130-001	8.0 x 9.0	2	8	1.0	9.0	3.0	C2	15.0	28.0	27.0	21.0
115-100-002	115-120-002	115-130-002	8.0 x 9.0	4	16	0.5	9.0	3.0	C2	15.0	28.0	27.0	21.0
115-100-003	115-120-003	115-130-003	16.0 x 10.0	5	16	1.0	10.0	3.0	C2	23.0	34.0	37.0	25.0
115-100-004	115-120-004	115-130-004	16.0 x 10.0	5	32	0.5	10.0	3.0	C2	23.0	34.0	37.0	25.0
115-100-005	115-120-005	115-130-005	16.0 x 13.0	2.25	16	1.0	13.0	3.0	C2	22.0	37.0	36.0	29.0
115-100-006	115-120-006	115-130-006	24.0 x 19.0	2.25	16	1.5	19.0	3.0	C2	30.0	45.0	30.0	37.0
115-100-007	115-120-007	115-130-007	64.0 x 10.0	5	64	1.0	10.0	3.0	C4	84.0	36.0	32.0	36.0

General Use Probes



Applications

- General weld inspection
- Tubes, pipes, tanks, pressure vessels
- Axles, forgings, castings
- Bridges and other structures
- Railroad wheels and rail
- Pumps, valve housings
- Turbine blades, shafts
- Wheel rims

Features

- Wide range of applications
- 3 different connector types available
- Used with wedges, delay lines, or wear caps
- Used for sector scanning or linear scanning

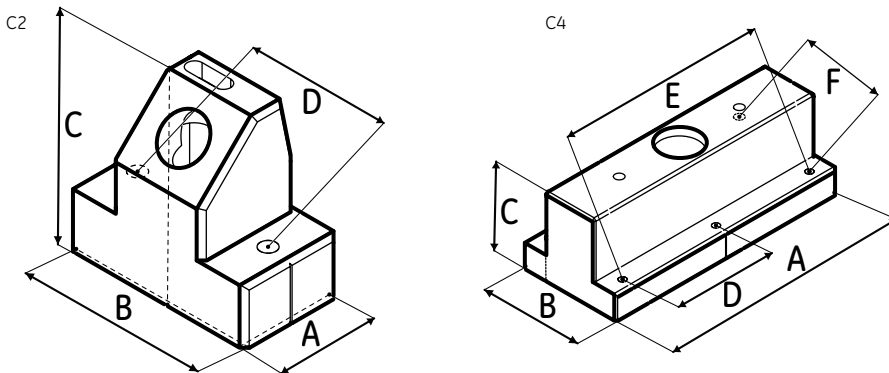

Part number Phasor	Part number Hypertronics	Part number Omniscan®	Aperture (mm)	Frequency (MHz)	Element Count	Pitch (mm)	Elevation (mm)	Cable (m)	Case Style	A (mm)	B (mm)	C (mm)	D (mm)	E (mm)	F (mm)
115-100-001	115-120-001	115-130-001	8.0 × 9.0	2	8	1.0	9.0	3.0	C2	15.0	28.0	27.0	21.0	-	-
115-100-002	115-120-002	115-130-002	8.0 × 9.0	4	16	0.5	9.0	3.0	C2	15.0	28.0	27.0	21.0	-	-
115-100-003	115-120-003	115-130-003	16.0 × 10.0	5	16	1.0	10.0	3.0	C2	23.0	34.0	37.0	25.0	-	-
115-100-004	115-120-004	115-130-004	16.0 × 10.0	5	32	0.5	10.0	3.0	C2	23.0	34.0	37.0	25.0	-	-
115-100-005	115-120-005	115-130-005	16.0 × 13.0	2.25	16	1.0	13.0	3.0	C2	22.0	37.0	36.0	29.0	-	-
115-100-006	115-120-006	115-130-006	24.0 × 19.0	2.25	16	1.5	19.0	3.0	C2	30.0	45.0	30.0	37.0	-	-
115-100-007	115-120-007	115-130-007	64.0 × 10.0	5	64	1.0	10.0	3.0	C4	84.0	36.0	32.0	36.0	71.0	28.0

Wedges/Delay Lines/Wear Caps for General Use Probes

Features

- Sectorial scanning
- Small footprint design
- Curved wedges available
- Optional carbide and couplant ports

* Z-Offset is the dimension from the center of the array mounted on the wedge to the bottom of the wedge (perpendicular to the bottom). This value is used to calculate delay laws in the Phasor.

* WF (Wedge Front) is the dimension from the center of the array mounted on the wedge to the front of the wedge. This value is entered into the Phasor and directly affect the frame of reference from which all projection results are measured.

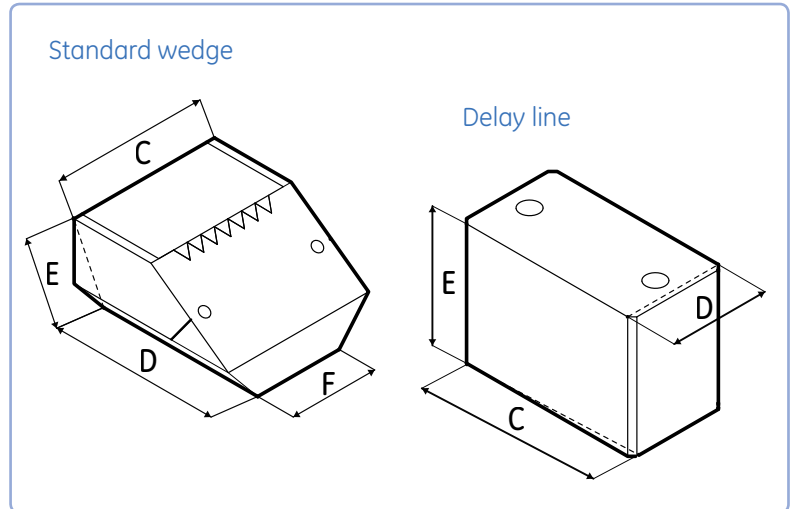

Accessories Part numbers

Part number Phasor	Part number Hypertronics	Part number Omniscan®	Shear Wedge 35° to 75°	Delay Line 20 mm (0.79")	Delay Line 40 mm (1.58")	Wear Cap
115-100-001	115-120-001	115-130-001	118-350-024	118-350-036	118-350-048	118-240-003
115-100-002	115-120-002	115-130-002	118-350-024	118-350-036	118-350-048	118-240-003
115-100-003	115-120-003	115-130-003	118-350-025	118-350-037	118-350-049	118-240-004
115-100-004	115-120-004	115-130-004	118-350-025	118-350-037	118-350-049	118-240-004
115-100-005	115-120-005	115-130-005	118-350-027	118-350-039	118-350-063	118-240-001
115-100-006	115-120-006	115-130-006	118-350-028	118-350-040	118-350-064	118-240-002
115-100-007	115-120-007	115-130-007	360-141-182 (sweep angle) 118-350-026 (fixed angle, lateral sweep)	118-350-038	118-350-050	118-240-005

Standard Wedges	C (mm)	D (mm)	E (mm)	F (mm)	Incident	Z-Offset * (mm)	WF * (mm)
118-350-024	28.2	24.7	15.0	12.3	36	10.6	18.7
118-350-025	33.5	32.6	18.5	21.3	36	12.4	24.1
118-350-026	84.0	54.8	31.1	84.1	36	20.6	40.5
360-141-182	35.6	124.5	59.9	35.6	36	35.3	65.8
118-350-027	37.3	37.8	22.9	22.0	36	15.9	28.9
118-350-028	45.4	50.0	29.6	26.4	36	20.5	37.4

Standard Delay Lines	C (mm)	D (mm)	E (mm)
118-350-036	28.2	15.0	20.0
118-350-037	33.5	23.0	20.0
118-350-038	84.0	35.6	20.0
118-350-039	37.3	21.0	20.0
118-350-063	37.3	21.0	40.0
118-350-040	45.4	30.0	20.0
118-350-064	45.4	30.0	40.0

Standard Delay Lines	C (mm)	D (mm)	E (mm)
118-350-048	28.2	15.0	40.0
118-350-049	33.5	23.0	40.0
118-350-050	84.0	35.6	40.0

Corrosion Probes

Applications

- Remaining wall thickness, corrosion, erosion
- Near surface flaw detection
- Bond testing

Features

- Amazing near surface resolution; 1.9 mm (0.075") on a #4 flat bottomed hole (1.5 mm / 0.062" diameter)
- Optimum test range 1.9 mm (0.075") to 25.4 mm (1") in steel
- Adjustable wear bars
- Available with 3 different connectors

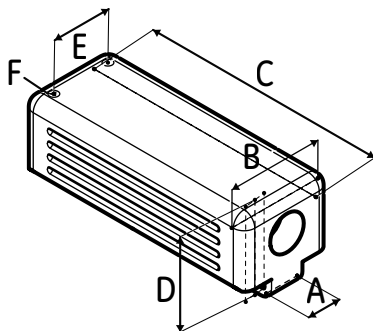

Part number Phasor	Part number Hypertronics	Part number Omniscan®	Aperture (mm)	Frequency (MHz)	Element Count	Pitch (mm)	Elevation (mm)	Cable (m)	A (mm)	B (mm)	C (mm)	D (mm)	E (mm)	F
115-100-020	115-120-020	115-130-020	48.0 x 10.0	5	Dual 32	1.5	5.0	3.0	9.1	25.4	65.5	24.4	16.0	M3X0.5
115-100-021	115-120-021	115-130-021	24.0 x 10.0	5	Dual 32	0.8	5.0	3.0	9.1	25.4	41.0	24.4	16.0	M3X0.5

Accessories for Corrosion Probes

Features

- Curved wear bars for alignment on curved pipe
- Flat wear bars for durability on flat plate
- Potted wear bars for flat or curved bars with fittings for couplant feed

Curved wear bars



Curved wear bars



Long flat wear bars



Flat ported wear bars



Curved ported wear bars

Flat Wear Bars	Mate
389-075-530	115-100-020, 115-120-020, 115-130-020
389-075-540	115-100-021, 115-120-021, 115-130-021

Curved Wear Bars	Mate
389-075-560	115-100-020, 115-120-020, 115-130-020
389-075-570	115-100-021, 115-120-021, 115-130-021

Curved Ported Wear Bars	Mate
389-077-160	115-100-020, 115-120-020, 115-130-020
389-077-150	115-100-021, 115-120-021, 115-130-021

Flat Ported Wear Bars	Mate
389-076-700	115-100-020, 115-120-020, 115-130-020
389-077-140	115-100-021, 115-120-021, 115-130-021

MSWS Probes



Applications

- General weld inspection, smaller objects, thinner sections
- Tubes, pipes, pressure vessels, containers
- Pumps, valve housings
- Turbine blades, shafts
- Wheel rims

Features

- Small contact area
- Fits on standard single element MSWS wedges
- Comparable to standard single element MSWS probes with Phased Array capabilities
- Available with 3 different connectors

MSWS 1

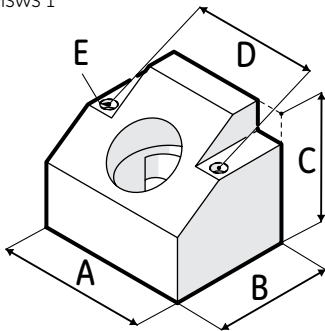

MSWS 2

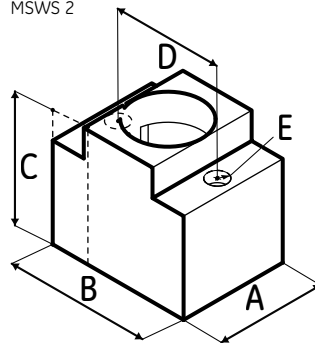

Part number Phasor	Part number Hypertronics	Part number Omniscan®	Aperture (mm)	Frequency (MHz)	Element Count	Pitch (mm)	Elevation (mm)	Cable (m)	Case Style	A (mm)	B (mm)	C (mm)	D (mm)	E
115-100-010	115-120-010	115-130-010	12.8 × 12.7	5	32	0.4	12.7	3	MSWS1	19.1	15.1	16.3	16.0	#1-64
115-100-011	115-120-011	115-130-011	12.8 × 12.7	10	32	0.4	12.7	3	MSWS1	19.1	15.1	16.3	16.0	#1-64
115-100-015	115-120-015	115-130-015	6.35 × 6.35	10	16	0.4	6.35	3	MSWS2	9.5	12.6	11.2	9.5	#1-64
115-100-012	115-120-012	115-130-012	12.8 × 12.7	5	16	0.8	12.7	3	MSWS1	19.1	15.1	16.3	16.0	#1-64
115-100-013	115-120-013	115-130-013	12.8 × 12.7	2.25	16	0.8	12.7	3	MSWS1	19.1	15.1	16.3	16.0	#1-64
115-100-037	115-120-037	115-130-037	6.4 × 6.4	5	16	0.4	6.4	3	MSWS2	9.5	12.6	11.2	9.5	#1-64

Wedges for MSWS Probes

Features

- Delay line or wedge attachment
- Small contact area
- Custom wedge angles and curvatures can be special ordered
- Manual or automated inspections

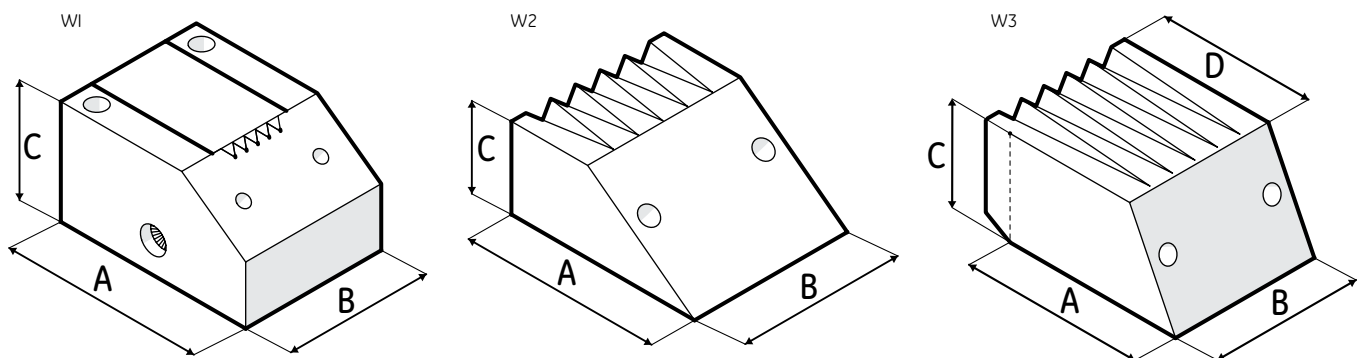

Mates to Case style	Wedge Style	Order Code	Shear Wave Carbon Steel	A (mm)	B (mm)	C (mm)	D (mm)
MSWS2	W1	360-141-219	30-80 DG	22.9	16.8	12.9	-
MSWS2	W2	118-340-028	45 DG	15.2	12.7	6.7	-
MSWS2	W2	118-340-030	60 DG	16.6	12.7	7.6	-
MSWS2	W2	118-340-032	70 DG	18.5	12.7	8.2	-
MSWS2	W2	118-340-034	80 DG	20.2	12.7	8.5	-
MSWS2	W3	118-340-036	90 DG	15.2	12.7	8.6	17.4
MSWS1	W2	118-340-040	45 DG	23.9	19.1	10.9	-
MSWS1	W2	118-340-042	60 DG	26.7	19.1	12.6	-
MSWS1	W2	118-340-044	70 DG	29.8	19.1	13.5	-
MSWS1	W2	118-340-046	80 DG	32.4	19.1	14.0	-
MSWS1	W3	118-340-048	90 DG	26.3	19.1	14.8	30.2

Scribeline Probes



Applications

- General weld inspection, smaller objects, thinner sections
- Tubes, pipes, pressure vessels, containers
- Pumps, valve housings
- Turbine blades, shafts
- Aircraft lap joint inspections

Features

- Small contact area
- Available in 3 different connectors

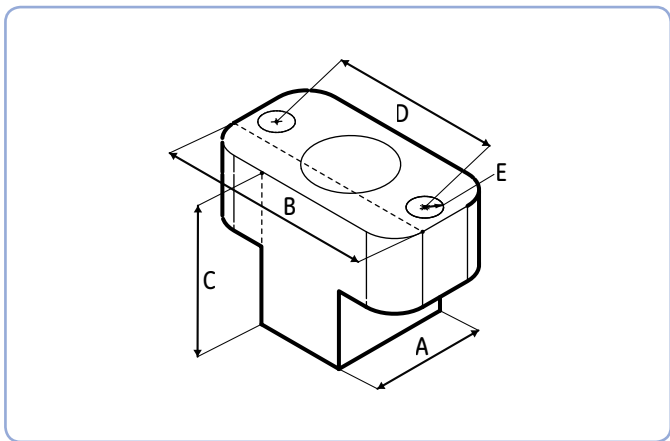

Part Number Phasor	Part Number Hypertronics	Part number Omniscan	Aperture (mm)	Freq. (MHz)	Element Count	Pitch (mm)	Elev. (mm)	Cable (m)	A (mm)	B (mm)	C (mm)	D (mm)	E
115-100-017	115-120-017	115-130-017	5.0 x 5.0	10	16	0.3	5.0	3.0	11.0	21.0	15.0	17.0	M3X0.5
115-100-016	115-120-016	115-130-016	5.0 x 5.0	5	16	0.3	5.0	3.0	11.0	21.0	15.0	17.0	M3X0.5

Wedges/Delay line for Scribeline Probes

Features

- Delay line and wedge attachment
- Small contact area
- Custom wedge angles and curvatures can be special ordered
- Manual or automated inspections

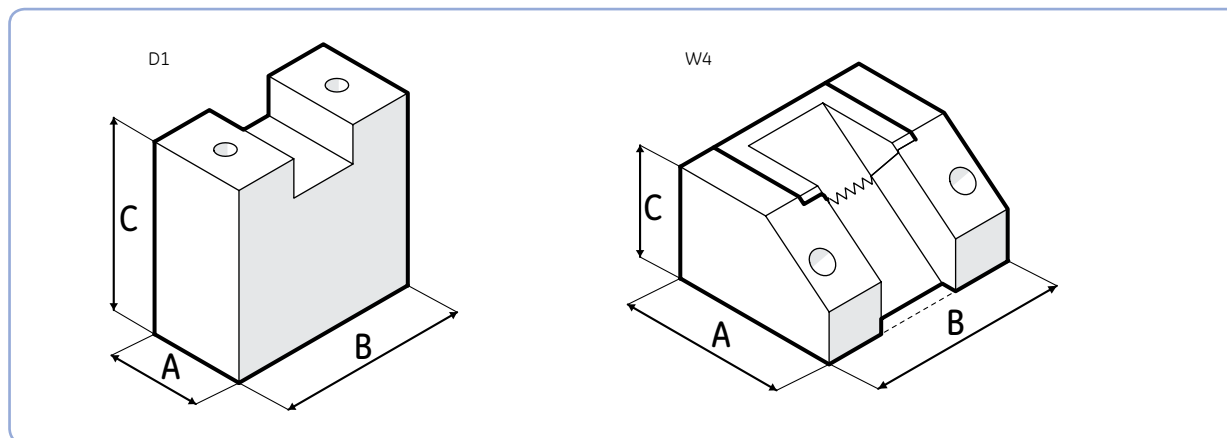

Order Code	Wedge	A (mm)	B (mm)	C (mm)
360-141-129	W4	17.8	21.3	11.6
360-141-148	W4	20.8	21.3	10.2

Order Code	Delay line	A (mm)	B (mm)	C (mm)
389-081-360	D1	12.7	25.4	19.9
389-071-220	D1	12.7	25.4	10.0

Hardwater Probes



Applications

- Composite inspection
- Bubbler applications where water is an issue

Features

- Probes use hardwater delay* to minimize water required for coupling
- Delay acoustically matched to water to minimize the water to delay interface
- Available with 3 different connectors

*Hardwater delay is a material applied to the face of the probe that is non-removable.

Main benefits:

Acoustically matches water to minimize interface echo.
 Improves near surface resolution.
 Decreases operating gain and frequency. (5MHz design frequency operates at approximately 2.6MHz)

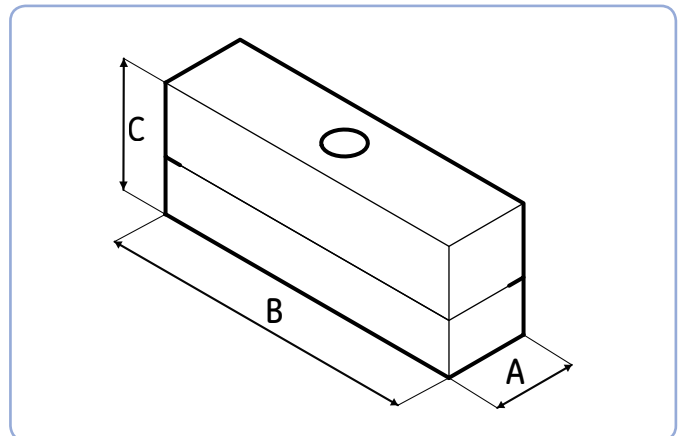

Part number Phasor	Part number Hypertronics	Part number Omniscan	Aperture (mm)	Freq. (MHz)	Element Count	Pitch (mm)	Elev. (mm)	Cable (mm)	A (mm)	B (mm)	C (mm)
115-100-027	115-120-027	115-130-027	40.6 x 8.0	5	32	1.3	8.0	6.0	13.0	43.0	31.0
115-100-028	115-120-028	115-130-028	81.2 x 8.0	5	64	1.3	8.0	6.0	13.0	86.0	31.0

Accessories for Hardwater Probes



Features

- Bubbler fixture for automated or hand scanning
- Available with or without encoder
- Applies 0.050" water coupling to hardwater probe

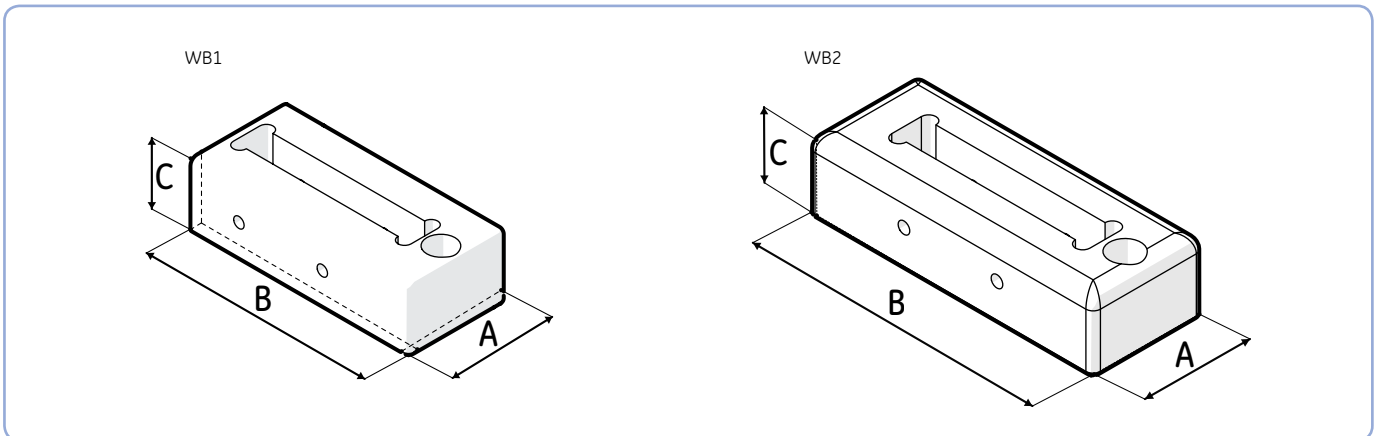

Part Number	Waterbox	Description	Mating Probe	A (mm)	B (mm)	C (mm)
022-509-571	WB1	Waterbox with side mount encoder module	Hardwater Probe, 115-100-028, 115-120-028, 115-130-028	48.0	106.0	31.0
389-064-070	WB2	Waterbox, no encoder		48.0	125.0	31.0
389-074-200	WB2	Waterbox with mini encoder				

Immersion Probes

Applications

- Composite plate inspection
- Immersion scanning area coverage
- Plates, billets and bars
- Disks, axles and shafts
- Large area scanning

Features

- Acoustically matched for best efficiency in water
- Fixture mountable
- Fast inspection of large areas
- Waterproof design
- Near wall design allows close access to edge of case (~1 mm)
- 6 meter cable



IM2 & IM3

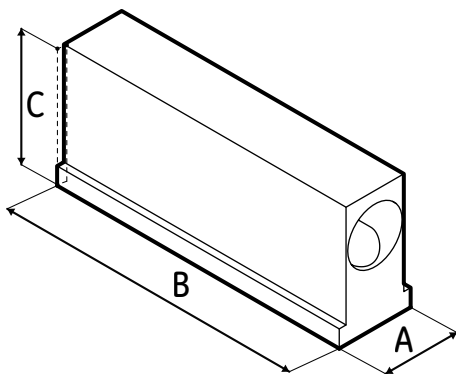

INW2

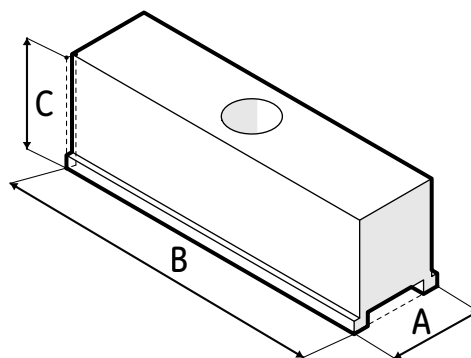

Part number Phasor	Part number Hypertronics	Part number Omniscan®	Aperture (mm)	Frequency (MHz)	Element Count	Pitch (mm)	Elevation (mm)	Cable (m)	Case Style	A (mm)	B (mm)	C (mm)
115-100-035	115-120-035	115-130-035	64.0 x 7.0	3.5	64	1.0	7.0	6.0	INW2	19.0	65.9	22.0
115-100-036	115-120-036	115-130-036	64.0 x 7.0	5	64	1.0	7.0	6.0	INW2	19.0	65.9	22.0
N/A	115-120-031	115-130-031	76.8 x 10.0	5	128	0.6	10.0	6.0	IM2	21.0	83.0	35.0
N/A	115-120-032	115-130-032	64.0 x 7.0	10	128	0.5	7.0	6.0	IM2	21.0	83.0	35.0
N/A	115-120-033	115-130-033	96.0 x 12.0	2.25	128	0.8	12.0	6.0	IM3	21.0	102.0	35.0
N/A	115-120-034	115-130-034	96.0 x 10.0	5	128	0.8	10.0	6.0	IM3	21.0	102.0	35.0

High Resolution Probes

Typical Applications

- Thin Plate, near surface defects, small defects

Advantages

- High frequency highly damped arrays for near surface inspections
- Acoustically matched to water/delay material
- Waterproof design

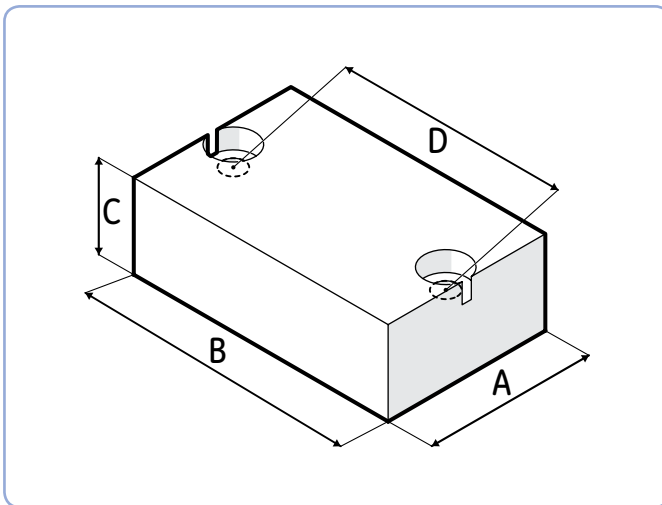

Part number Phasor	Part number Hypertronics	Part number Omniscan®	Aperture (mm)	Frequency (MHz)	Element Count	Pitch (mm)	Elevation (mm)	Cable (m)	Case Style	A (mm)	B (mm)	C (mm)	D (mm)	E
115-100-025	115-120-025	115-130-025	16.0 x 10.0	10	32	0.5	10.0	3.0	HRD1	23.8	38.5	12.7	32.2	M3X.5
115-100-026	115-120-026	115-130-026	32.0 x 10.0	10	64	0.5	10.0	3.0	HRD1	23.8	54.5	12.7	48.2	M3X.5

Removable Delay Line (included with transducer)	Transducer number
387-007-296 (12.7 mm length)	115-100-025, 115-120-025, 115-130-025
387-007-295 (12.7 mm length)	115-100-026, 115-120-026, 115-130-026

RotoArray



Applications

- Primarily for the inspection of composite materials and structures
- Flaw detection and thickness measurement in a wide range of materials
- Inspection during manufacture as well as for in service inspection

Features

- Excellent acoustic performance
- Use in any attitude including overhead
- Transparent tire for easy bubble removal
- Unique encoder
- 3 popular connector options
- Owner serviceable
- Platform for future models
- Interactive digital manual on UTprobes.com

Standard 0-59 mm width array

The compact 51.2 mm RotoArray is designed for quick and easy scanning of a variety of different applications. Its small design allows it to be used in tight locations and its light weight and ergonomic design keeps the operator from becoming fatigued during long periods of use.

Part number Phasor	Part number Hypertronics	Part number Omniscan®	Coverage area (mm)	Frequency (MHz)	Pitch (mm)	Elements	Elevation (mm)	Focus	Cable (m)	Probe Offset (mm)
115-910-100	115-920-100	115-930-100	51.2	5	0.8	64	6.4	Flat	3.0	28.2

Standard 60-99 mm width array

The 81.3 mm RotoArray is currently our only standard offering in the 60-99 mm range. Its larger size makes it ideal for inspecting airframes and fuselages.

Part number Phasor	Part number Hypertronics	Part number Omniscan®	Coverage area (mm)	Frequency (MHz)	Pitch (mm)	Elements	Elevation (mm)	Focus	Cable (m)	Probe Offset (mm)
115-910-200	115-920-200	115-930-200	81.3	5	1.3	64	8.0	Flat	3.0	28.2

Accessories for RotoArray

Included Accessories



The accessories included with the RotoArray allow for full functionality, and help to keep it maintained and functioning.

Optional Accessories



The optional accessories are highly recommended for the RotoArray and provide an ease of maintenance, verification, and use. The comprehensive RotoArray Service Station is one of the most useful accessories allowing users to minimize downtime by carrying out any necessary repairs and maintenance on a customized workbench fitted with all the necessary tools.

	Included / Optional Accessories	Part Numbers	115-910-100	115-920-100	115-930-100	115-910-200	115-920-200	115-930-200
Encoder 3 meter cable to 7 pin Lemo	Included (if Yes)	388-000-506	YES	YES	YES	YES	YES	YES
Frame Assembly w/ handels	Included (if Yes)		YES	YES	YES	YES	YES	YES
3 switch assembly w/ 3meter lemo	Included (if Yes)	388-000-500	NO	YES	YES	NO	YES	YES
Fluid fill bottle assembly	Included (if Yes)	389-079-240	YES	YES	YES	YES	YES	YES
Couplant Spray bottle	Included (if Yes)	021-265-015	YES	YES	YES	YES	YES	YES
Propylene Glycol 1Qt	Included (if Yes)	111-200-559	YES	YES	YES	YES	YES	YES
RotoArray tool kit	Included (if Yes)	388-000-502	YES	YES	YES	YES	YES	YES
RotoArray spare parts kit	Included (if Yes)	388-000-503	YES	YES	YES	YES	YES	YES
Case	Included (optional large or small)	Small= 021-026-099 Large= 021-026-354	Small or large	Small or large	Small or large	Small or large	Small or large	Small or large
Adapter Cable	Included (if Yes) (optional DBHD or Fisher)	DBHD= 388-000-501 Fisher= 388-000-525	NO	DBHD-15 or Fisher	DBHD-15 or Fisher	NO	DBHD-15 or Fisher	DBHD-15 or Fisher
Tire Change Station	Optional	389-079-390	Optional	Optional	Optional	Optional	Optional	Optional
Ergonomic Water Sprayer	Optional	021-265-020	Optional	Optional	Optional	Optional	Optional	Optional
Demo Block Kit	Optional	389-081-400	Optional	Optional	Optional	Optional	Optional	Optional

Integral Wedge Probes

Applications

- General weld inspection: MWB for small parts, SWB for thick parts
- Other applications where conventional MWB or SWB probes are in use

Features

- Easy transfer from conventional to phased array inspection
- Durable and ergonomically-designed, die-cast housing as known from conventional probes
- Existing mechanics and probe holders can be re-used
- Non-detachable wedges, no coupling loss between probe and wedge
- Replacement soles (sold separately) for extended service life

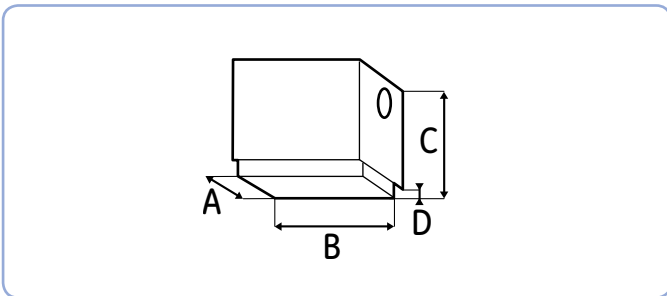

Part number Phasor	Part number Hypertronics	Part number Omniscan®	Probe Description	Aperture (mm)	Frequency (MHz)	Element Count	Pitch (mm)	Elevation (mm)	Cable (m)	Case Style	A (mm)	B (mm)	C (mm)	D (mm)
69141	69732	69730	MWB2PA16	8.0 x 9.0	2	16	0.5	9.0	2.0	MWB	14.0	24.0	22.0	2.0
69142	69733	69731	MWB4PA16	8.0 x 9.0	4	16	0.5	9.0	2.0	MWB	14.0	24.0	22.0	2.0

Part number Phasor	Part number Hypertronics	Part number Omniscan®	Probe Description	Aperture (mm)	Frequency (MHz)	Element Count	Pitch (mm)	Elevation (mm)	Cable (m)	Case Style	A (mm)	B (mm)	C (mm)	D (mm)
69143	69738	69736	SWB2PA16	14.0 x 14.0	2	16	0.9	14.0	2.0	SWB	22.0	37.0	31.0	3.0
69144	69739	69737	SWB4PA16	14.0 x 14.0	4	16	0.9	14.0	2.0	SWB	22.0	37.0	31.0	3.0

021814

Certification of Conformity

115-000-546 64EL .5MM PITCH ARRAY

Monday, July 12, 2010

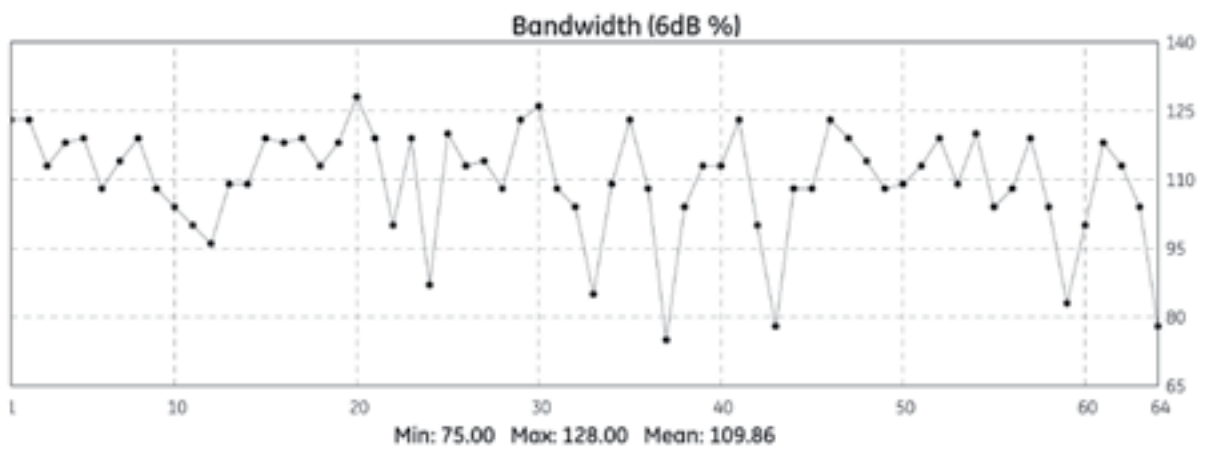
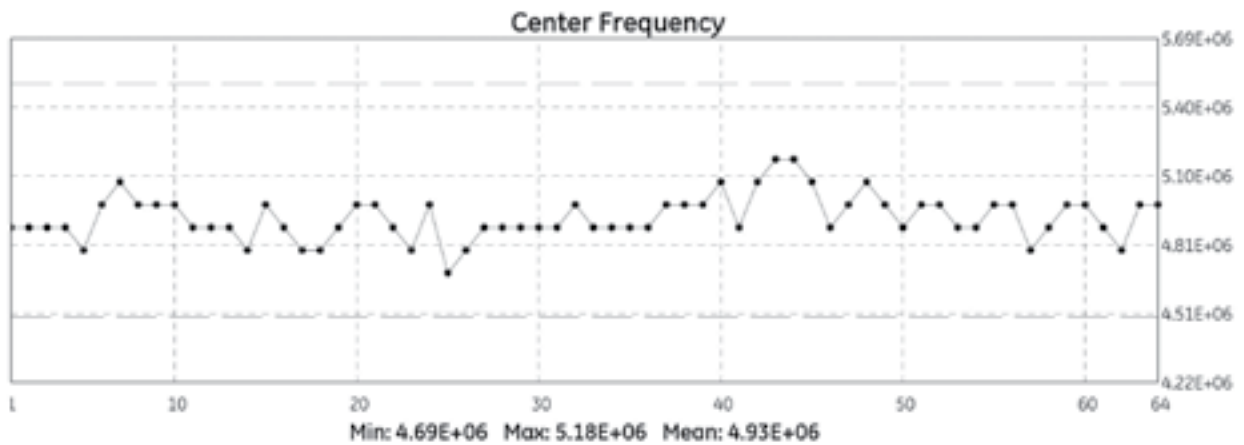

The Ultrasonic Transducer listed above has been performance tested and meets all manufacturing specifications. It performed as designed and specified on the applicable style of Krautkramer instrumentation.

The accuracy of the transducer described above has been confirmed by factory standard test equipment and laboratory reference standards traceable to the National Institute of Standards and Technology. This facility's Quality System is registered to ISO 9001-2008, and is compliant to MIL-STD-45662A and ANSI/NCSL Z540-1-1994.

GE Inspection Technologies, LP
50 Industrial Park Rd.
Lewistown, PA 17044
Tel: 717.242.0327
Fax: 717.242.2606
GEInspectionTechnologies.com

021-247-480, Rev 1



GE imagination at work

021814

Certification of Conformity

115-000-546 64EL .5MM PITCH ARRAY

Monday, July 12, 2010

Element 9 Time Waveform

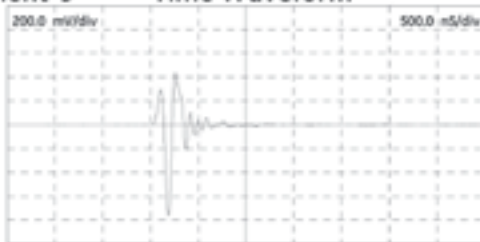

Spectrum

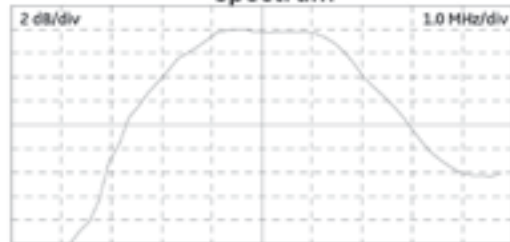

Element 18 Time Waveform

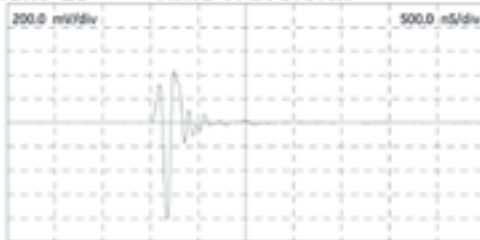

Spectrum

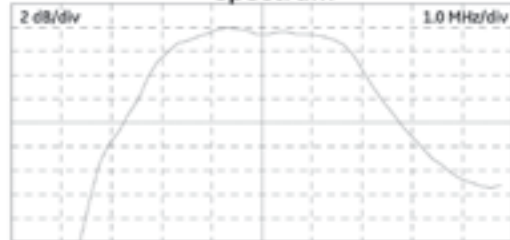

Element 27 Time Waveform

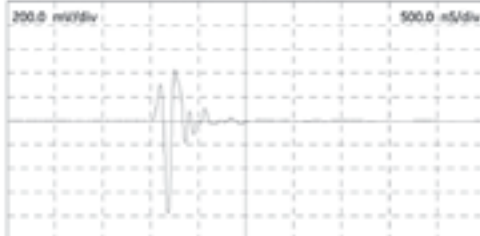

Spectrum

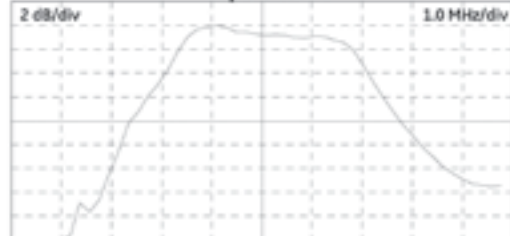

The Ultrasonic Transducer listed above has been performance tested and meets all manufacturing specifications. It performed as designed and specified on the applicable style of Krautkramer instrumentation.

The accuracy of the transducer described above has been confirmed by factory standard test equipment and laboratory reference standards traceable to the National Institute of Standards and Technology. This facility's Quality System is registered to ISO 9001-2008, and is compliant to MIL-STD-45662A and ANSI/NCSL 2540-1-1994.

GE Inspection Technologies, LP
50 Industrial Park Rd.
Lewistown, PA 17044
Tel: 717.242.0327
Fax: 717.242.2606
GEInspectionTechnologies.com

021-247-480, Rev 1



GE imagination at work

021814

Certification of Conformity

115-000-546 64EL .5MM PITCH ARRAY

Monday, July 12, 2010

Element 36 Time Waveform

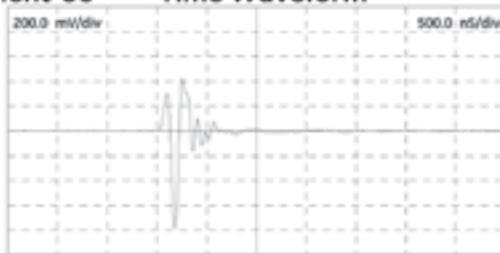

Spectrum

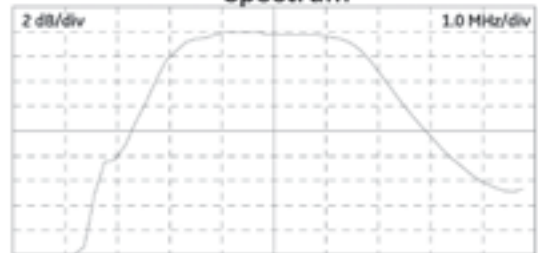

Element 45 Time Waveform

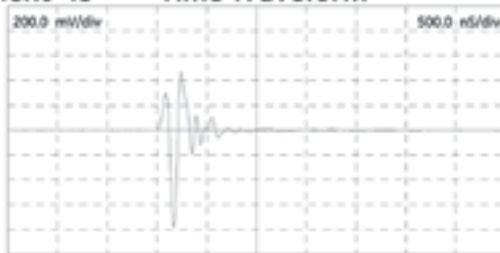

Spectrum

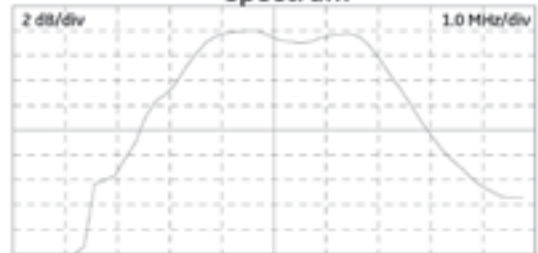

Element 54 Time Waveform

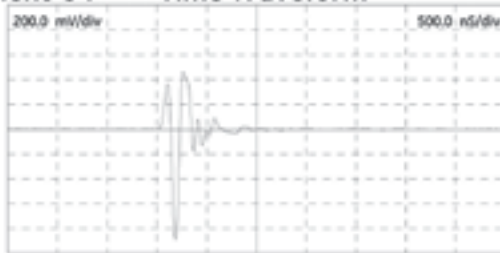

Spectrum

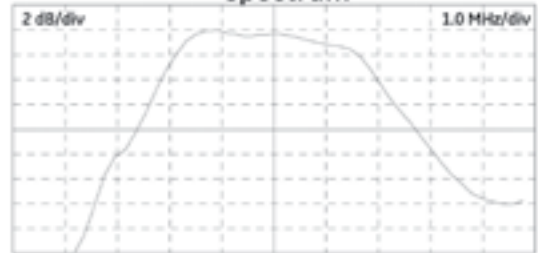

The Ultrasonic Transducer listed above has been performance tested and meets all manufacturing specifications. It performed as designed and specified on the applicable style of Krautkramer instrumentation.

The accuracy of the transducer described above has been confirmed by factory standard test equipment and laboratory reference standards traceable to the National Institute of Standards and Technology. This facility's Quality System is registered to ISO 9001-2008, and is compliant to MIL-STD-45662A and ANSI/NCSL Z540-1-1994.

021-247-480, Rev 1

GE Inspection Technologies, LP
50 Industrial Park Rd.
Lewistown, PA 17044
Tel: 717.242.0327
Fax: 717.242.2606
GEInspectionTechnologies.com



GE imagination at work

021814

Certification of Conformity

115-000-546 64EL .5MM PITCH ARRAY

Monday, July 12, 2010

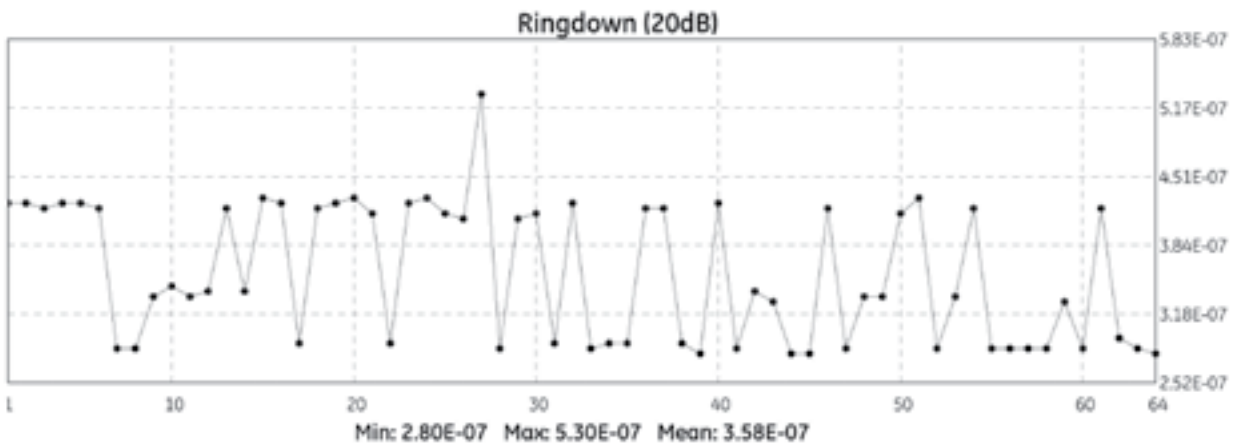
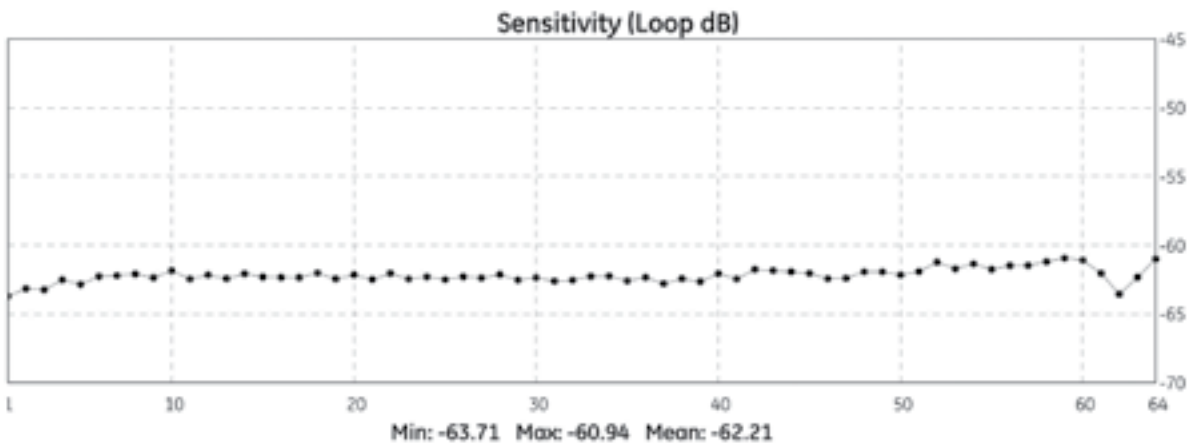

The Ultrasonic Transducer listed above has been performance tested and meets all manufacturing specifications. It performed as designed and specified on the applicable style of Krautkramer instrumentation.

The accuracy of the transducer described above has been confirmed by factory standard test equipment and laboratory reference standards traceable to the National Institute of Standards and Technology. This facility's Quality System is registered to ISO 9001-2008, and is compliant to MIL-STD-45662A and ANSI/NCSL 2540-1-1994.

GE Inspection Technologies, LP
50 Industrial Park Rd.
Lewistown, PA 17044
Tel: 717.242.0327
Fax: 717.242.2606
GEInspectionTechnologies.com

021-247-480, Rev 1



GE imagination at work

021814

Certification of Conformity

115-000-546 64EL .5MM PITCH ARRAY

Date Tested	7/12/2010 6:52:51 AM
Operator	BA
Test Specification	0512170
Test Specification Rev	C
Oscilloscope Serial Number	8747-DP310-001
Oscilloscope Cal Date	10/31/10
UTA Serial Number	MM00107
UTA Cal Date	6/14/2011
Software Designation	FNT0101
Software Rev	A

021-247-480, Rev 1

GE Inspection Technologies, LP
50 Industrial Park Rd.
Lewistown, PA 17044
Tel: 717.242.0327
Fax: 717.242.2606
GEInspectionTechnologies.com



GE imagination at work

021814

Certification of Conformity

115-000-546 64EL .5MM PITCH ARRAY

Monday, July 12, 2010

TOF Wiring Verify

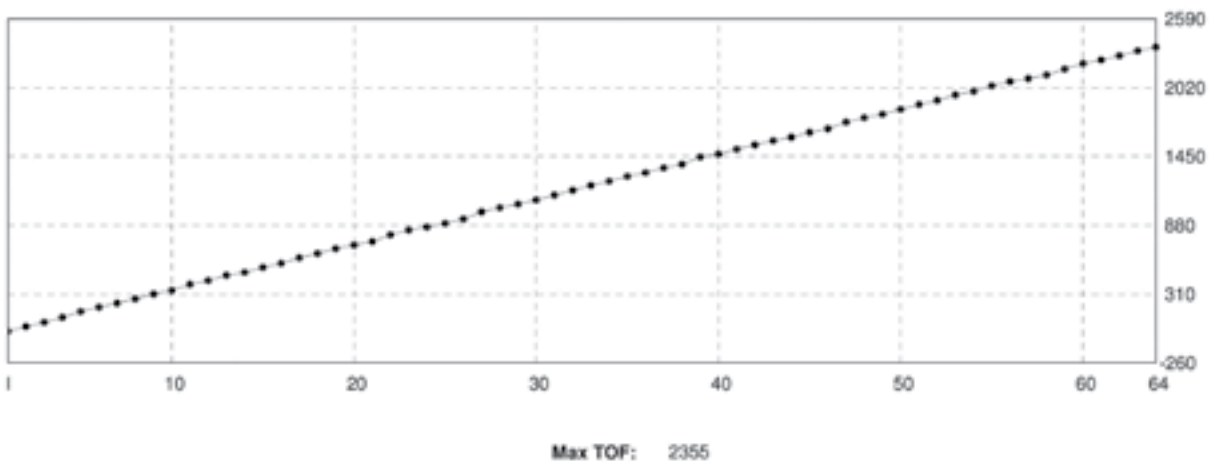

The Ultrasonic Transducer listed above has been performance tested and meets all manufacturing specifications. It performed as designed and specified on the applicable style of Krautkramer instrumentation.

The accuracy of the transducer described above has been confirmed by factory standard test equipment and laboratory reference standards traceable to the National Institute of Standards and Technology. This facility's Quality System is registered to ISO 9001-2008, and is compliant to MIL-STD-45662A and ANSI/NCSL 2540-1-1994.

GE Inspection Technologies, LP
50 Industrial Park Rd.
Lewistown, PA 17044
Tel: 717.242.0327
Fax: 717.242.2606
GEInspectionTechnologies.com

021-247-480, Rev 1



GE imagination at work

Integral Wedge Probes Certificate

GE

Measurement & Control

Technische Daten / Technical data				Min. Toleranz	Max. Toleranz	Min. Toleranz	Max. Toleranz	Einheit
Element	T ₀ / μs	L / MHz	E ₀ / %					
1	0,60	4,18	88,8	2,0	4	5,1	6	mm
2	0,91	4,33	77,8	5	8	8,5	12	mm
3	0,92	4,33	88,8	5	12	11	18	mm
4	0,64	4,32	85,8	var	15	17	17	mm
5	0,89	4,33	88,8	5,0	---	43,2	---	Einheitskreis
6	0,91	4,33	88,7	5,0	---	27,0	---	mm
7	0,68	4,33	88,3	2	---	8,5	---	mm
8	0,91	4,38	88,8	5	---	18	---	mm
9	0,62	4,27	89,7	5,0	---	11,0	---	mm
10	0,88	4,29	87,4					
11	0,83	4,32	86,3					
12	0,89	4,38	88,7					
13	0,91	4,38	88,3					
14	0,94	4,40	88,3					
15	0,89	4,38	88,3					
16	0,75	4,22	83,8					

Hersteller / Model	Serien-Nr. / Serial no.	Produktions- / Mfg. no.	Kalibrierdatum / Cal. Date	Gültig bis / Due Date
GE SAT GmbH / USM25 PK-Messplatz	7821	9885	12.08.2012	12.08.2013
Teilname / TID: ID12	8018372	8538	25.01.2012	25.01.2014
Schreiber / V1-100	8	0403	18.02.2012	18.02.2014
GE SAT GmbH / M30	2113	3883	09.05.2011	09.05.2013
GE SAT / Kontrollkörper 41.2"		8143	12.08.2011	12.08.2013

Teilname	41.2" Integral probe
Material	Flussblech / Fluxplate
Ballgeschwindigkeit / Sound velocity	2730 m/s
Refaktor / Refactor	ebene Rückwand / Flat backwall
Abstand / Distance	30 mm
Kabelänge / Cable length	3m
Stecker / Connector	Type

PZ(E)

Prüfkopf-Typ / Probe type: HWB4PA16
 Ident-Nr. / Ident no.: 0881A2
 Serien-Nr. / Serial no.: 00558_00
 Prüfvorschrift / Spec: 10691A2_00010001
 Prüfdatum / Test date: 29.10.2012
in Anb. E2642_pos08.2009

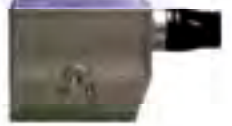

rel. Homogenität / rel. homogeneity

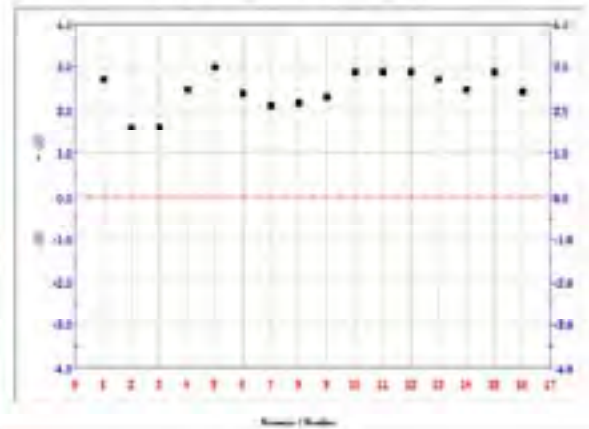

Waveforms and spectra

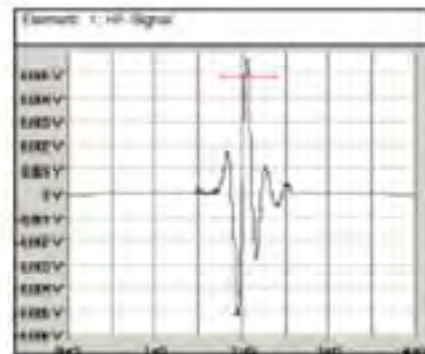
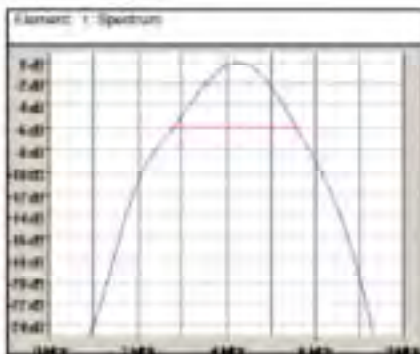

Regional Offices

Europe

Germany

Robert Bosch Strasse 3
50354 Huerth
+49 2233 6010

Lotzenäcker Strasse 4
72379 Hechingen
(RVI only)
+49 (0) 7471 9882 0

Niels-Bohr-Strasse 7
31515 Wunstorf
P.O. Box 6241
(RT only)

31510 Wunstorf
+49 5031 172 0

Bogenstrasse 41
22926 Ahrensburg
(RT only)
+49 4102 807 117

United Kingdom

892 Charter Avenue Canley
Coventry CV4 8AF
+44 845 130 3925

France

68, Chemin des Ormeaux
Limonest 69760
+33 47 217 9220

Spain

San Maximo, 31, Planta 4A, Nave 6
Madrid 28041
+34 915 500 59 90

Americas

United States

50 Industrial Park Road
Lewistown, PA 17044
+1 866 243 2638 (toll free)
+1 717 242 0327

721 Visions Drive
Skaneateles, NY 13152
(RVI only)
+1 888 332 3848 (toll free)
+1 315 554 2000 ext. 1

Brazil

Av. das Nacoes Unidas, 8501 1st floor
São Paulo, SP 05425-070
Tel: + 55 3067 8166

GE Sensing & Inspection Technologies has sales and service offices all over the world. Below are some of our locations. Visit www.geit.com for a complete listing.

- Berchem, Belgium
- Alzenau, Germany
- Burford, United Kingdom
- Moscow, Russia
- Bucharest, Romania
- Prague, Czech Republic
- Stockholm, Sweden
- Milan, Italy

Asia

China

5F, Building 1, No.1 Huatuo Road,
Zhangjiang High-Tech Park,
Shanghai 201203
+86 800 915 9966 (toll-free)
+86 (0) 21-3877 7888

Unit 1602, 16/F Sing Pao Building
101 King's Road
North Point
Hong Kong
+852 2877 0801

Japan

7F Medie Corp Bldg. 8
2-4-14 Kichijoji Honcho, Musashino-shi
Tokyo 180-0004
+81 442 67 7067

- East Perth, Australia
- Singapore
- Dubai, UAE
- Buenos Aires, Argentina
- Mexico City, Mexico
- Airdrie, Alberta, Canada
- Toronto, Ontario, Canada
- Montreal, Quebec, Canada

www.UTprobes.com





Mentor UT

The power of ultrasonic phased array inspection meets everyday use.



Reimagine ultrasonic testing

Pressure is higher than ever to lower operating costs and improve productivity, amidst stringent regulations and rapidly advancing technology that is ever more complex and expensive. For NDT inspectors, delivering the most effective and reliable inspections to help customers meet those demands means overcoming the challenges of increasingly complex testing procedures, an increasing number of instrument parameters to understand, and the growing loss of domain expertise.

Despite the accuracy and versatility of Ultrasonic Phased Array Testing (PAUT), the design of PAUT equipment currently available on the market can increase the cost of these inspections while decreasing the efficiency and consistency. Complicated inspection processes require extensive inspector training, while instruments designed to gather a wealth of data for a range of use-cases can lead to inconsistency among procedures.

But what if performing high-quality and efficient UT inspections was as easy as using a smartphone? With Mentor UT from GE, it is.



Mentor UT offers a new kind of inspection experience by combining outstanding UT performance, customizable workflow applications and user interfaces, and intuitive hardware with embedded expertise—making inspections more accessible and efficient.

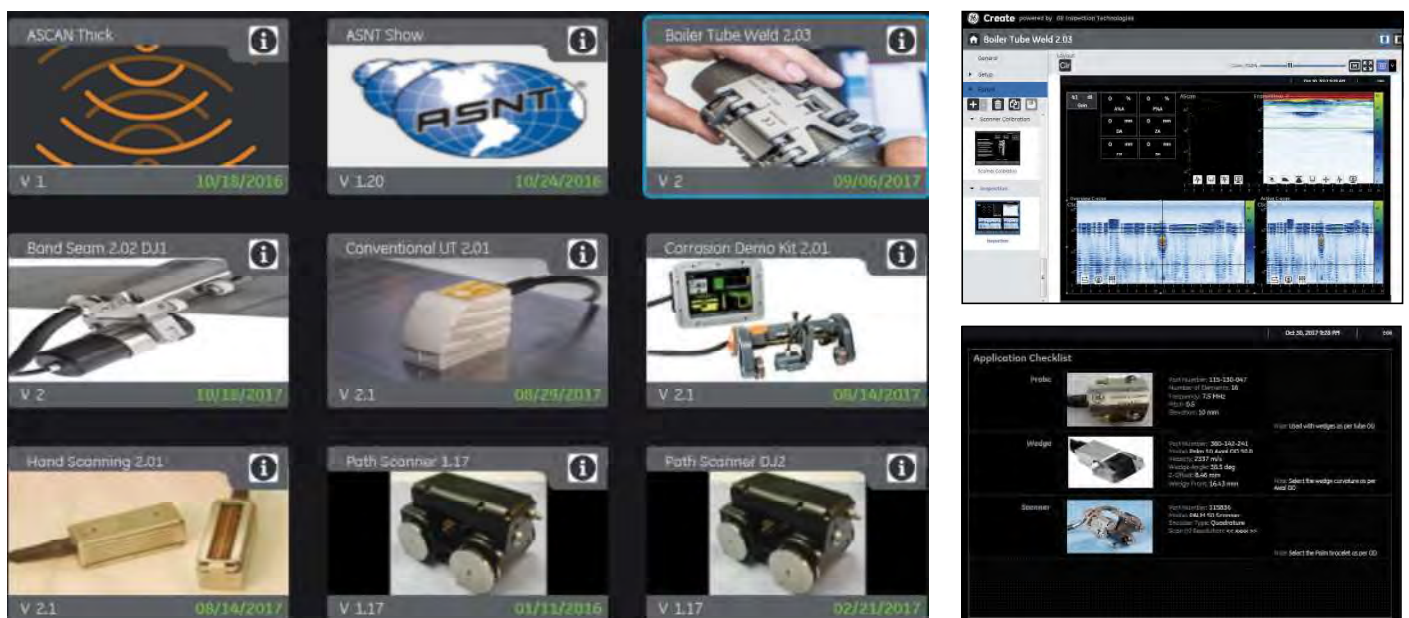

Using Mentor Create is as easy as creating a powerpoint presentation, with each screen in the Mentor Create App acting like it's own slide.

Design your own inspection workflows for Mentor UT using GE's desktop software, Mentor Create. Customize inspection "apps" tailored to your unique testing procedures, industry applications and experience levels that can be as detailed or generic as each individual user sees fit.

User defined menus walk technicians through every step of an inspection—from probe selection and

calibration to reporting—ensuring consistency across your inspections, every time, from every inspector. And with the flexibility to load multiple workflows on one device, you can guarantee constant access to the right workflow needed for your inspection.

With Mentor UT, you get more productive, quality inspections.

Power meets performance

Mentor UT was developed with the quality and precision you expect from GE.

Field-ready right out of the box

Take the guesswork out of inspection setup with probe kits and inspection apps already installed on your Mentor UT device. Whether you're inspecting composites, welds, bolts, erosion or corrosion, create workflows that run the gamut from simple to extensive using GE-provided on-device apps for basic inspections. Reference guides are also immediately accessible during field inspections with pictures, videos, training documents and detailed inspection procedures.

Collaborative by design— save time and resources

Every Mentor UT is InspectionWorks enabled. This makes it the first UT device to easily allow wireless connectivity and live streaming. Now you can get expert advice or a second opinion for tough inspection calls when you need it—in real-time.

Rugged durability

Mentor UT stands up to tough environments with its IP65 durability rating—tested for water and dust resistance, extreme heat and humidity, cold, vibration, shocks and drops.

High-performance design

With 20 kHz pulse repetition frequency (PRF), Mentor UT combines a 32:32 phased array flaw detector (upgradable to 32:128) with a conventional UT channel to instantly switch between phased array and conventional inspections as needed.

Intuitive operation

With a glove-friendly, daylight-readable touchscreen, data collection, archiving and reporting are simplified with the ability to store A-scan data, as well as post-inspection analyses, right on the device.



Ultrasonic Testing is not one-size-fits-all.

Maximize your investment with unparalleled compatibility

A fleet of Phased Array Transducers is a significantly larger investment than a fleet of single element transducers. That's why Mentor UT was designed with three connector options. Easily pair the instrument with GE's rugged, field-proven line of probes and a variety of commercially available aftermarket scanners and robotic systems to meet a range of inspection needs.



For a low cost, lightweight option, connect directly to your Mentor UT device



Mentor UT delivers integral standard probe connection. Choose from commonly found Tyco or Ipex options.



MUX with increased capability up to 32:128 available with Tyco or Ipex options.

General specifications

Physical	
Dimensions (W x H x D)	295 mm x 230 mm x 60 mm (12" x 9.4" x 2.4")
Weight, w/Battery	2.9 kg (6.5 lbs)

Display	
Size	264 mm (10.4") diagonal
Resolution	1024 x 768 pixels
Mode	Indoor and outdoor specific color modes
Viewing Angle	± 85° all directions

Touch Screen (Multi-touch)	
Gloved Operation	Yes
Surface	Chemically strengthened glass, scratch resistant, chemical resistant, optically bonded to display

Data Storage	
Solid State Hard Drive	128 GB
USB Storage	USB 2.0 w included module
Data Capture	Full ASCAN capture for every CSCAN point, all settings. Recall on instrument with full analysis capability
Data Files	memd files, CSV files
Settings Files	All instrument settings plus position in workflow
Screen Capture	JPG Format
Report	PDF Format

Connectivity	
Wi-Fi	802.11 b, g, n
Connectors	USB 2.0, Ethernet, HDMI
Remote Collaboration	Local Network and Internet-Enabled via InspectionWorks Connect
InspectionWorks	Enabled

I/O	
Axes	2 digital quadrature encoders for X-Y axes
Audible	Tone, 2.7 kHz

Power	
Internal Battery	63 WH Lithium Ion
External Battery	84 WH Lithium Ion
Power Supply	100 to 240 VAC, 47-63 Hz, 1.9 A; 12VDC
Battery Life	3 hrs internal, 6 hrs with external battery under typical operating conditions
Compliance	Meets IATA air transport regulations with one contained installed battery and one packed external battery

Environmental	
Operating Temperature	-20C to +55 C (-4F to 131F) to MIL-STD-810G Method 501.5 & 502.5, Procedure I
Storage Temperature	-20C to +70C (-4F to 158F) to MIL-STD-810G Method 501.5 & 502.5, Procedure II
Ingress Protection	Tested to IP65
Shock	4' Transit Drop to MIL-STD-810G method 516.6, Procedure V

Data Visualization	
User Interface	Customizable with Mentor Create software
Zoom	Any data view may be expanded to full screen with gesture
Instructional Material	Rich Text, JPG, PNG, BMP, PDF or Video (MP4)
Views	A-SCAN, C-SCAN, C-SCAN OVERVIEW, E-SCAN, S-SCAN
Probe Selection	Swap between conventional and phased array on same screen
Evaluation	2 Gates, one can be used as interface echo gate
Measurements	Amplitudes, Depth, Distance, % Wall Loss, Thinnest Point, X and Y Positions
Calibrations	Phased Array: TCG, Material Velocity, Probe Delay, Auto80, Encoder Cal, Dead Element Check Conventional: 2 Point (Material Velocity and Probe Delay)

Ultrasonic specifications

Configuration	
Phased Array	
Channels	32
Aperture	1–32 Elements
Max Elements	32
Focal Laws	1024
Scanning	Linear, sectorial, focused
Conventional	
Channels	1
Pulsar (Phased Array and Conventional)	
PRF	10 Hz to 20 kHz
Pulse Shape	Bipolar or unipolar square wave
Voltage	20–150 V _{pp} , 0 - -75V _{up} ; in 5 V steps
Width (auto or manual)	50–3000 nS
Delay Step Increment	10 nS
Receiver and Digitizer (Phased Array and Conventional)	
Gain	0–78 dB (Phased Array), 0–94 dB (Conventional); in 0.2 dB steps
TCG	
Number of Points	Up to 16
Slope	50 dB/μS
Rectification	Pos HW, Neg HW, Full, RF
Bandwidth	0.5 MHz to 15 MHz
Digitizing Rate	62.5 MHz, up-sampled to 500 MHz
Delay Step Increment	2.5 nS
Acquisition Range	50 nS to 150 μS
ASCAN Compression Points	512, 1024, 2048, 4096

MUX module specifications

Physical	
Dimensions (W x H x D)	8.6" x 8.4" x 4.1"
Weight, w/Battery	6.5 lbs
Power	
Exchangable Battery, hot swap	84 WH Lithium Ion
Power Supply	100 to 240 VAC, 47–63 Hz, 1.9 A; 12VDC
Configurations	
Phased Array	
Channels	32
Aperture	1–32 Elements
Max Elements	128
Focal Laws	1024
Scanning	Linear, sectorial, focused
Conventional	
Channels	1

With GE, innovation is the standard.

True to form for the world's preeminent Digital Industrial Company, GE's industry-leading Mentor platform of connected NDT portables is designed to enable reliable inspection for all users, regardless of experience level. With outstanding performance and advanced software, the Mentor family of products is ready and able to help your organization improve inspection productivity and equipment reliability.

GE Inspection Technologies

50 Industrial Park Drive
Lewistown, PA 17044
(717) 242-0327
www.geinspectiontechnologies.com

© 2017 General Electric Company. All rights reserved.

GEA32151A (12/2017)



NEW USM Vision 1.2

A Total Weld Inspection Solution to Increase Productivity in New Process Pipework Fabrication

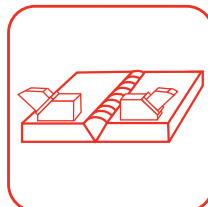

Parallel scanning



Linear scan



16/128

More channels



GE imagination at work

Introduction

The USM Vision has been developed to meet a market need to transition from radiographic inspection to ultrasonic inspection in the fabrication of new process pipework for the process, water, power generation and oil & gas sectors. Conventional film radiography has long been the preferred method of weld inspection in fabrication shops and it provides excellent results, which are easy to understand.

However, film radiography is necessarily accompanied by significant restraints, such as safety considerations, chemicals storage, waste disposal, long film development times, and film archiving.

Ultrasonic inspection suffers from none of these restraints and, although it cannot be used instead of radiography in every instance, it offers accurate, code-compliant, reliable and fast data. Unfortunately, this type of inspection requires a qualified ultrasonics inspector. And highly skilled ultrasonics inspectors can often be very difficult to find.

NEW USM Vision 1.2

Following user feedback, the scope and functionality of the USM Vision has been extended. This field-proven, pipe weld inspection system now features parallel scanning, and supports 128 element Phased Array Probes. With parallel scanning, both sides of the weld are scanned in one pass, effectively doubling productivity. The system also incorporates the ability to use up to 128 element Phased Array probes instead of 64 element versions, so that linear Phased Array scans can now be carried out for pipes of even greater wall thickness.

USM Vision, the Efficient Solution to Managing Task Sharing

The USM Vision provides a cost-effective and elegant solution to the problem. It allows ultrasonics to be applied to pipe weld inspection, eliminating the constraints of film radiography and allows tasks in the inspection process to be shared among non-ultrasonics specialists (e.g. radiography inspectors with minimum ultrasonics training) and highly qualified ultrasonics experts, so that optimum use is made of the time of all levels of NDT technicians. The highly qualified ultrasonic personnel can focus on the task for which he is most valuable, like set-ups validation and data analysis, and manage several UT trained operators doing inspection plan creation, calibration and field data acquisition.

And all this with no compromise on accuracy and reliability of data and a significant improvement in productivity.

Compliance codes

ASME V
B31.3
API 1104
ASTM E 2373
B31 Case 181
Code Case 2235

EN ISO 17640
EN ISO 10863
Pr EN ISO 13588

DICONDE

USM Vision Rationalizes

Inspections Plan Creation and Validation

Creating an Inspection Plan

No ultrasonic knowledge is required to create and populate an inspection plan. All that is required is to describe the inspection task, and enter the basic information such as site location, number of welds, pipe diameter, thickness and material, weld preparation, procedure and method to be used. The software will then calculate and generate all the UT set-ups required to perform TOFD and/or Phased Array inspection of the specified welds. These set-ups include:

- selection of the correct probes and wedges from a database
 - positioning of the probe
 - positioning of the required UT parameters
- to perform an efficient inspection according to the standard and code-based procedure selected.

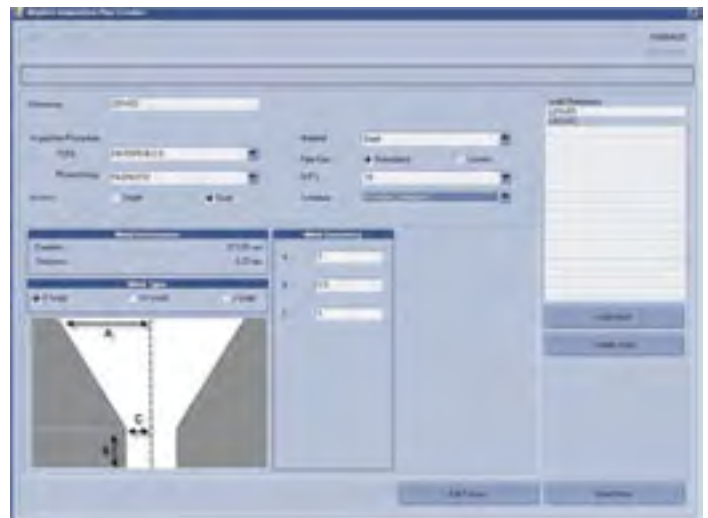

Validating an Inspection Plan

A technician qualified in ultrasonics must then validate the set-ups. Each weld is split in one or several passes with TOFD or PA technique. The UT specialists have to validate these passes by using a ray tracing tool. They also have the ability to modify them by selecting another probe from the database, adjusting the probe(s) position(s). When all the passes are validated, the inspection plan can be exported to the acquisition unit.

NEW The import and export function for inspection plan files is simplified so that the inspection plan can be exported without forwarding the entire database.

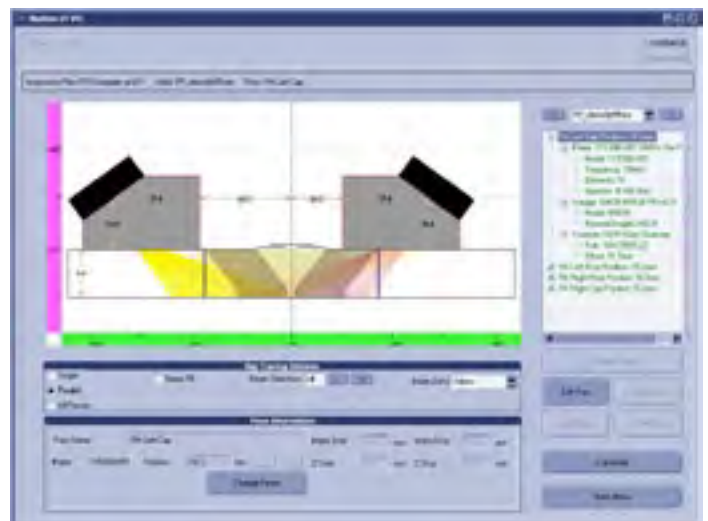

s the Weld Inspection Pro

Calibration and Data Acquisition

Calibration

As the data acquisition is 100% guided, this task doesn't require a highly trained UT operator. The technician merely selects an inspection plan, and is then guided through a step-by-step process from the probe and wedge validation, UT calibration (PCS and sensitivity calibration for TOFD, element and wedge check, DAC / TCG curve recording for PA), scanner settings and calibration.

Acquiring the Inspection Data

The inspection data for each weld, is simply acquired by following the inspection plan and the different TOFD and PA passes calculated by the IPC. After each pass the software will propose the next weld or pass to be inspected helping the operator to use the best, most productive way in the inspection plan. Data can be exported, for one pass, one weld or for the complete inspection plan, for analysis and reporting at any time during the inspection.

NEW For Phased Array, the system can inspect the two sides of the weld with one physical scan which effectively doubles productivity. The instrument can now perform inspection with linear Phased Array scans as recommended in some codes. USM Vision 1.2 can handle probes up to 128 elements which means that pipes of greater wall thickness can be inspected with linear scans.

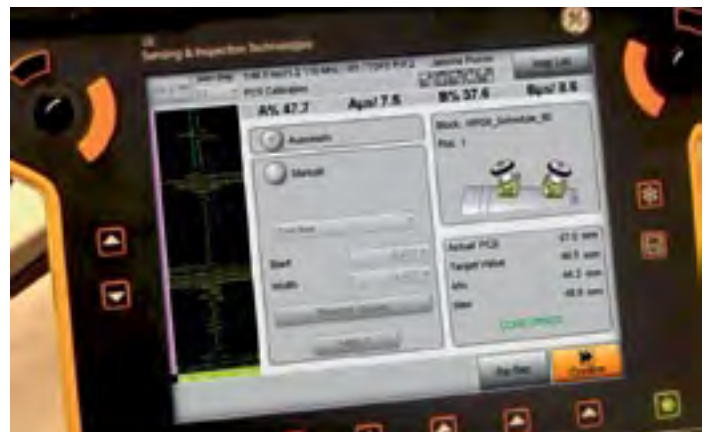

© Photo Courtesy of Fabricom

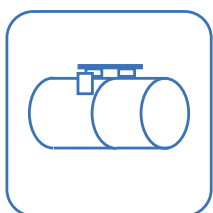

and Accurate Inspection

Archive and Share Data

Archiving the Inspection Data

The inspection data are saved in the Rhythm Archive software, allowing to save the raw data with necessary tags. Input and retrieval of information is quick and easy. This accepts data from any number of LAN-connected, remote Rhythm Review workstations and stores them using various compression techniques to save storage space without sacrificing data quality

Sharing the Inspection Data

All inspection data can be shared with other interested parties, either as enhanced imagery or as raw data. It can be transmitted to other Rhythm Review stations for third party verification.

Turning information into intelligence and sharing inspection data across experts and locations with ease!



Scope of Applications

The USM Vision has been developed to simplify and to democratize the Ultrasonic Inspection according to the international codes and standards through:

- Optimizing the use of specialized inspection personnel
- Increase productivity
- Reducing the current weld inspection radiographic constraints
- Reducing the ultrasonic weld inspection complexity

USM Vision is especially dedicated to:

- Energy construction industry
- Carbon steel and Stainless steel pipes
- Covers the Normalized Pipe Size (NPS) in automatic setup
 - Diameters from 73 mm (2.875") up to 1219 mm (48")
 - Thicknesses from 6 mm (1/4") up to 50 mm (2")
 - Higher thickness and diameter in manual setting
- Circumferential welds
- Short exit point wedges and short scanner arms available for pipe to elbow and pipe to flange



USM Vision a Total Weld Inspection Solution

The USM Vision is supplied as a complete weld inspection solution, consisting of:

- IPC software for creation of the inspection plan and automatic generation of the UT set-ups. Integrate a database with procedures based on international codes and standards and ray tracing functionality for the validation of the UT parameters.
- The USM Vision hand-held flaw detector, featuring:
 - Conventional channel, TOFD, 16/64 or 16/128 Phased Array, Real Time Volume Corrected Images, A-scan saving
 - Unique user interface to operate a pointing device by two trackballs
 - Ease of use for untrained operators
 - 26,5 cm (10.4") color touch screen with 1024 x 768 resolution
 - Weighs only 4 kg (8.8 lb)
 - Hot swap battery exchange for continuous operation
 - Robust, rubber housing, IP 54
 - Dimensions:
 - Length top: 367 mm (14.4")
 - Length bottom: 310 mm (12.2")
 - Width: 250 mm (9.8")
 - Height: varying from 60 to 100 mm (2.36" to 3.93")
 - Modern PC interfaces including USB, Ethernet, wireless connection (WiFi)
 - IPC and analysis software can be operated from the USM Vision
 - Transport case
- An encoder-scanner, designed for TOFD and Phased Array manual acquisition including:
 - Manual handle cart with magnetic wheels
 - Optional chain for the inspection of pipes
 - Arm with probe and center line pointer holders, forks for TOFD and PA wedges
 - Transport case
- Set of probes and wedges relating to the specified pipe ranges and inspection codes
- Rhythm Review 4.2 software for the analysis and reporting – Windows 7
- Optional Rhythm modules for archiving, sharing and advance reporting functionalities

Regional Contact Information

North America

50 Industrial Park Road
Lewistown, PA 17044
USA

+1866 243 2638 (toll free)
+1 717 242 0327

Europe

Robert-Bosch-Strasse 3
50354 Huerth
Germany

+49 2233 6010

Asia

5F, Building 1, No.1 Huatuo Road,
Zhangjiang High-Tech Park,
Shanghai 201203
China

+86 800 915 9966 (toll-free)
+86 (0) 21-3877 7888



www.geinspectiontechnologies.com

GEIT-20058EN (01/12)

Multi-Axis XYZ-TT-GS INDUSTRIAL IMMERSION SCANNING

Utilizing the very latest technologies, immersion inspection allows for internal and flaw detection. Parts are submerged in water which acts as a coupling medium for the ultrasonic probe. Internal and external inspection for defects or thickness measurement is very accurately carried out via the inspection software. Subsurface flaws, disbands, cracks and other irregularities can be analyzing for size, thickness, depth and other quantitative features.

- High speed low vibration Linear Motor
- Offline analysis for virtual re-scanning of parts that are no longer available
- Multi Axis scan options (X, Y, Z 1&2, Gimbal 1&2, Swivel 1&2 and Turntable)
- Contour following for inspection of curved parts
- Squirter transducer holder available
- Real-time A, B & C-scans
- Simultaneous Multi-zone inspection



Multi-Axis XYZ-TT-GS INDUSTRIAL IMMERSION SCANNING

OKOS Digital Imaging System



ODIS Acoustic Microscopy software with rich technical content is built on industry feedback. It includes both time domain and frequency domain imaging in real-time. Advanced analysis is provided through quantitative tools for measurement and classification of parts.

The Analysis version of ODIS allows non-scanning computers to virtually re-scan, view, and analyze data.

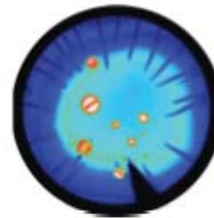

Defect Detection
Multiple Zones
Near Surface
Sub Surface
Inside Part



Feature	ODIS	Others
Ultra Large Scans (up to 40 GB)	✓	X
Ultra High Rep Rate (up to 30 KHz)	✓	X
90 Simultaneous Gates/Channel	✓	X
Multiple Gates on Multiple Channel	✓	Limited
Image Analysis	✓	✓

B-scan & SLICE Imaging



Advanced Software Controls for Engineers



Metals & Alloys

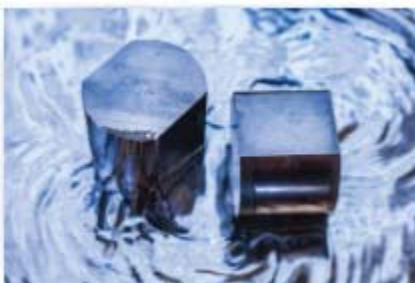

Turbine Blades



Composites

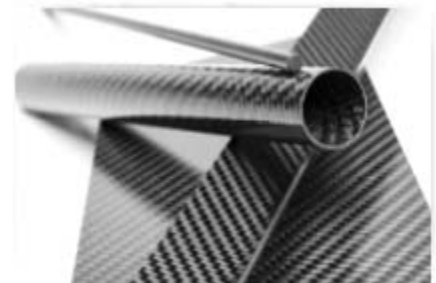

NDT-CF 300 Multi Axes NDT Scanner Compact Footprint

Ultrasonic NDT Inspection of

- Hard-cutting materials
- Composites
- Custom alloys
- Solder joints
- Plastics
- Printed circuit boards
- Turbine blades

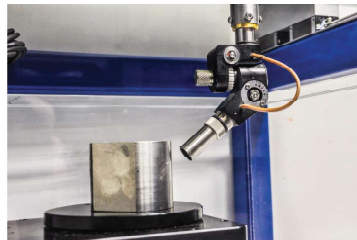

Gimbal



Turntable

- X, Y and Z linear axes
- Scan Envelope 300 mm x 300 mm x 150 mm
- Optional Turntable
- Optional Through Transmission Yoke
- Optional Gimbal
- 360 Degree view acrylic tank
- Optional linear servo on X axis

- 12-bit dynamic range instrumentation
- High gain Pulser/Receiver
- Hardware TGC/DAC control
- Application-specific transducers
- Full-featured NDT scanning software
- Off-line Analysis

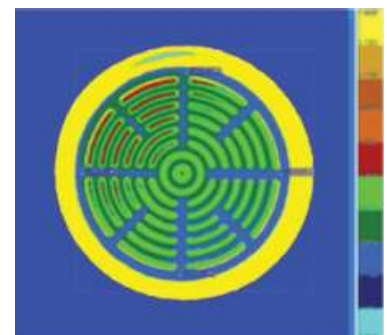

Defect Detection

- Multiple Zones
- Near Surface
- Sub Surface
- Inside Part

ODIS WinSAM Software Acoustic Microscopy Imager



ODIS WinSAM is the latest Acoustic Microscopy software with rich technical content built on current platforms and industry feedback.

It includes **both** time and **frequency domain** Imaging in real-time. The software provides advanced analysis through quantitative tools for measurement and classification of parts.

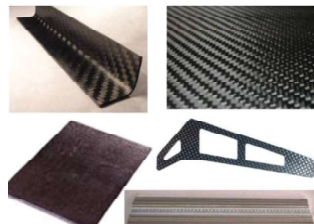

Composites



Metals and Alloys



Turbine blades



- Multi Axis scan options
- Highly customizable software
- A, B and C-scans

- Contour following
- Off-line analysis
- Virtual rescanning

info@okos.com



Multi-Gating

Virtual Rescanning

Thickness Measurements

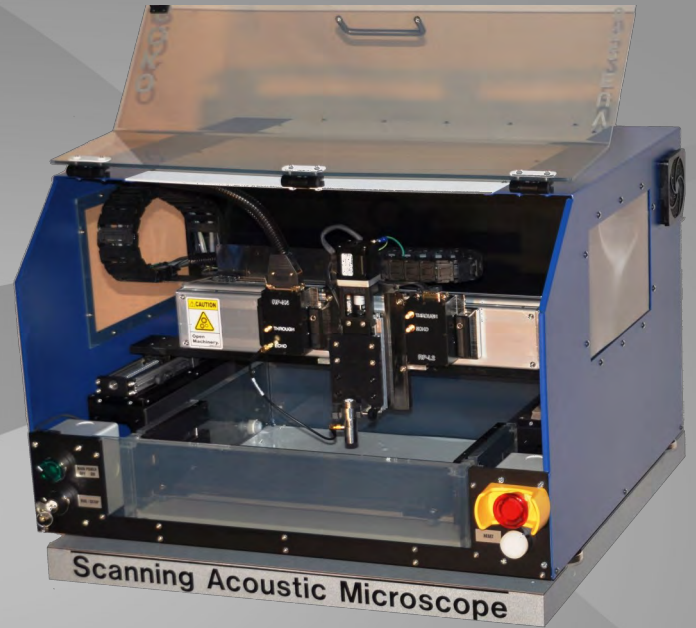

VUE 250-P

SCANNING ACOUSTIC MICROSCOPY

Semiconductor Package Failure Analysis

voids · disbonds · cracks · delamination · internal defects

Included Software Modes:

- Basic (user friendly)
- Advanced (detailed analysis)
- Offline Analysis (virtual scanning)



Real-time A-Scan & A-Scan Capture

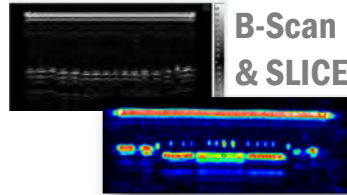

B-Scan & SLICE



Threshold Mapping (post processing)

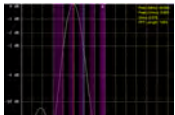
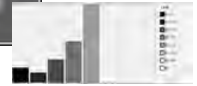

Frequency Domain Imaging (FFT)

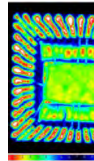

C-Scan with Multi-gate, SALI, & SALI Groups



Cluster Analysis (post processing)

Size (mil)	Area	Bounding Area	Bounds (mil)
7.45%	Total area: 1.57 mm ² 0.00 mm ²		
3.23%	0.88 mm ² 0.00 mm ²	1.10 mm x 0.90 mm	1.10 x 1.10
1.17%	0.30 mm ² 0.00 mm ²	0.40 mm x 0.40 mm	0.40 x 0.40
1.15%	0.30 mm ² 0.00 mm ²	0.36 mm x 0.36 mm	0.36 x 0.36
0.64%	0.17 mm ² 0.00 mm ²	0.20 mm x 0.20 mm	0.40 x 0.40
0.64%	0.17 mm ² 0.00 mm ²	0.20 mm x 0.20 mm	0.35 x 0.35
0.26%	0.07 mm ² 0.00 mm ²	0.08 mm x 0.08 mm	0.20 x 0.20



Scan Math Before and After Reflow Characterization



Advanced Time-of-Flight & Thickness Measurements

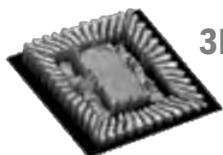

3D Imaging

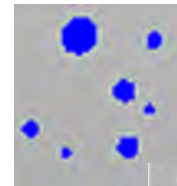

Void Gating (real-time)



SPECS

Maintenance Free Scan Axis

Motor: Linear Servo
 Max Velocity: 500 mm/s
 Accuracy & Repeatability: +/- 1.0 micron
 Scan Envelope: 250 mm

Low Maintenance Step Axis

Step Envelope: 150 mm

Low Maintenance Focus Axis

Focus Envelope: 35 mm

Dimensions

0.64 m x 0.61 m x 0.5 m (WDH)
 52 kg

Customer Interface

Dual 22" HD LED Monitors

Fixtures

Tray Fixture
Optional Through Transmission Bracket
 LED illumination

Instrumentation

Digital Pulser Receiver
 Up to 4 GHz Digitizer

Scan Area

Partial JEDEC Tray

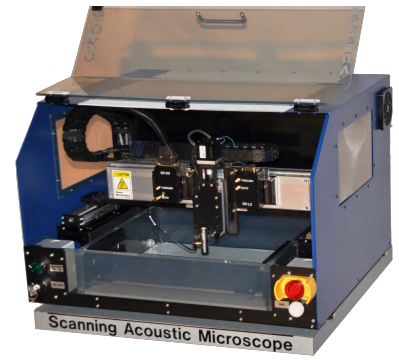

WORKSPACE

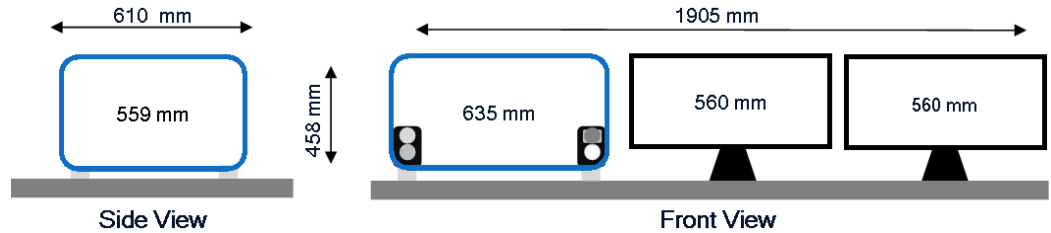

OKOS Digital Imaging System (ODIS)

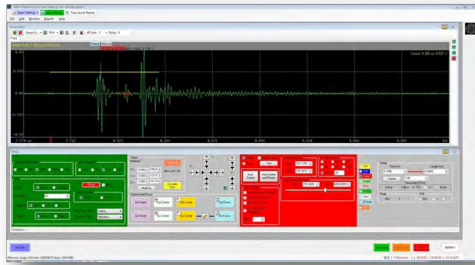

ODIS is the latest Acoustic Microscopy software with rich technical content built on current platforms and industry feedback. It includes both time domain and frequency domain imaging in real-time. Advanced analysis is provided through quantitative tools for measurement and classification of parts. The Analysis version of ODIS allows non-scanning computers to

- | | |
|-----------------------|--------------------|
| Counterfeit Detection | Product Inspection |
| Product Reliability | Quality Control |
| Process Validation | Failure Analysis |
| Vendor Qualification | R&D |

virtually scan, view, and analyze data for simultaneous real-time analysis or post collection review. Previously undetected flaws can now be imaged with poled peak analysis.



Application Specific Transducers

for the highest quality resolution. Multiple transducer designs for enhanced scan capability.

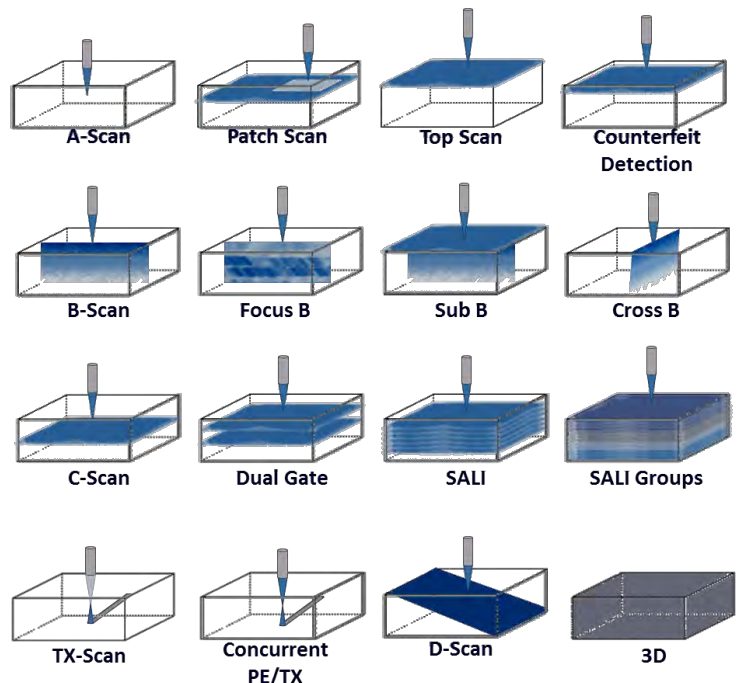

TEL +1 703 880 3039
 FAX +1 240 235 7277
www.okos.com
info@okos.com

4429 Brookfield Corporate Dr., STE 700, Chantilly, VA 20151, USA



Virtual
Rescanning

Pass/Fail
scan sorting

Flatness
Measurements

Multi-
Gating

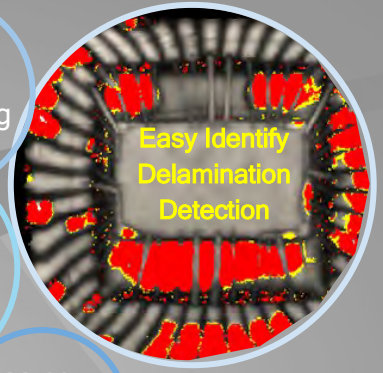

VUE 400-P

SCANNING ACOUSTIC MICROSCOPY
Semiconductor Package Failure Analysis
 voids · disbonds · cracks · delamination · internal defects

Included Software Modes:

- Basic (user friendly)
- Advanced (detailed analysis)
- Production (automated scanning)
- Offline Analysis (virtual scanning)

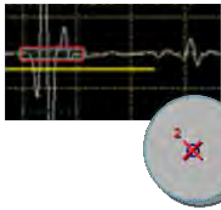

Real-time
A-Scan
&
A-Scan
Capture

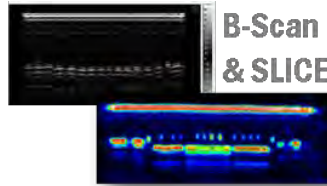

B-Scan
& SLICE



Threshold Mapping
(post processing)

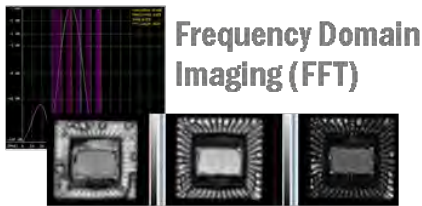

Frequency Domain
Imaging (FFT)



C-Scan with
Multi-gate, SALI,
& SALI Groups

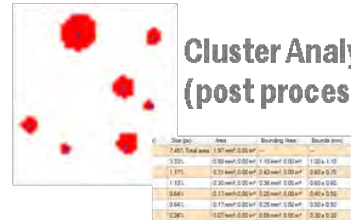

Cluster Analysis
(post processing)



Advanced Time-of-
Flight & Thickness
Measurements



Scan Math
Before and After
Reflow
Characterization

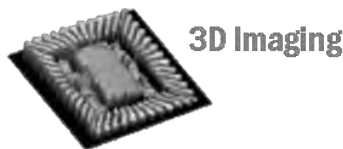

3D Imaging



Void Gating
(real-time)



SPECS

Maintenance Free Scan Axis

Motor: Quad Linear Servo
 Max Velocity: 1500 mm/s
 Accuracy & Repeatability: +/- 0.5 micron
 Scan Envelope: 380 mm

Low Maintenance Step Axis

Step Envelope: 350 mm

Low Maintenance Focus Axis

Focus Envelope: 50 mm

Dimensions

0.9 m x 0.86 m x 1.18 m (WDH)
 227 kg

Customer Interface

Dual 22" HD LED Monitors

Fixtures

Tray Fixture
Optional Through Transmission Bracket
 LED illumination

Instrumentation

Digital Pulsar Receiver
Optional second channel
 Up to 12 GHz Digitizer

Scan Area

Dual JEDEC Trays
 Up to 300 mm wafer



Clean Room Ready

OKOS Digital Imaging System (ODIS)

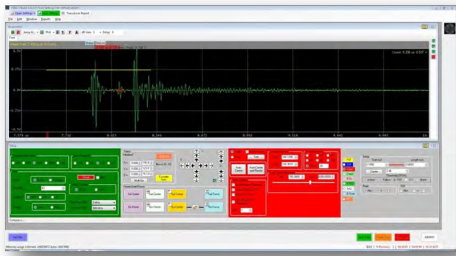

VUE 400-P imaging power surpasses modern standards delivering premium FA Lab features to semiconductor fabrication facilities. ODIS is the latest Acoustic Microscopy software with rich technical content built on current platforms and industry feedback. It includes

Counterfeit Detection

Product Inspection

Product Reliability

Quality Control

Process Validation

Failure Analysis

Vendor Qualification

R&D

both time domain and frequency domain imaging in real-time.

Advanced analysis is provided through quantitative tools for measurement and classification of parts. The Analysis version of ODIS allows non-scanning computers to virtually scan, view, and analyze data for simultaneous real-time analysis or post collection review. Previously undetected flaws can now be imaged with poled peak analysis. Supplied with your choice of Windows 7 or 8.



Application Specific Transducers

for the highest quality resolution. Multiple transducer designs for enhanced scan capability.

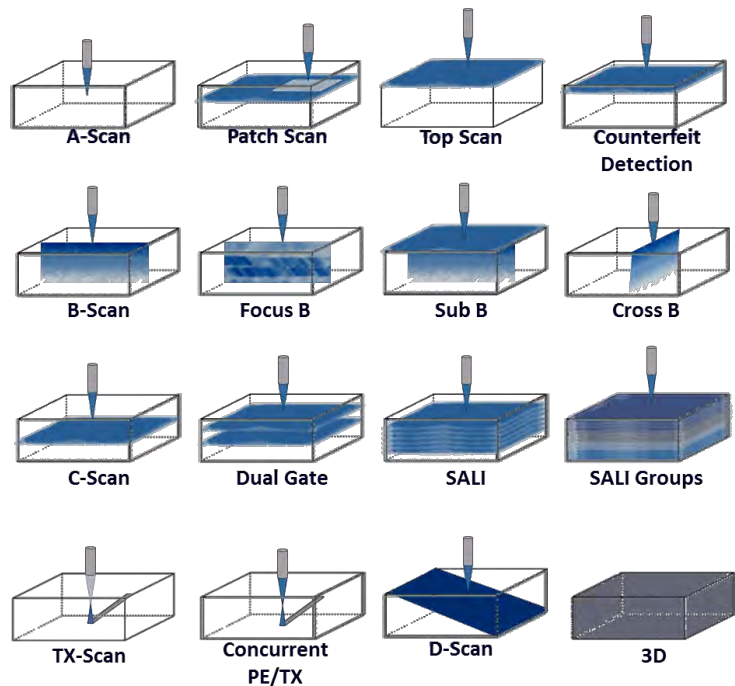

TEL +1 703 880 3039
 FAX +1 240 235 7277
www.okos.com
info@okos.com

4429 Brookfield Corporate Dr., STE 700, Chantilly, VA 20151, USA

GE
Inspection Technologies

USIP 40

Multi-Channel Ultrasonic
Inspection Instrument



The USIP40 is a precision, multi-channel inspection platform that can be configured as a remote ultrasonic unit, an integrated rack-mountable instrument, or as a portable battery-powered instrument. All USIP 40 versions take advantage of the same basic ultrasonic hardware, graphical user interface, and application specific software tools.



GE imagination at work

Performance and Productivity by Design.

The USIP 40 delivers precision, multi-channel ultrasonic testing performance you can rely on. It is available with up to ten ultrasonic channels and comes in three different package options – a remote ultrasonic unit, an integrated rack-mount instrument, or a fully portable, battery-powered instrument. All of these versions utilize the same core electronic hardware and Graphical User Interface. When you combine its outstanding ultrasonic performance with optional application specific imaging and analysis tools, you can see that the USIP 40 is the ultimate solution for your current and future inspection needs.

The Ultimate Inspection Confidence

Application specific GUI

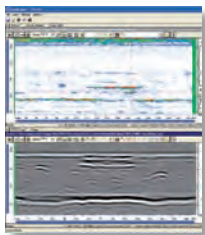

The USIP 40 takes full advantage of its Microsoft Windows™ based operating environment. Each of its instrument functions is designed as a separate plug-in.

This allows the operator to set-up a customized display showing the right information for a particular application. Several levels of graphical user interface

can be created with their own password protection to control access to specific functions.



EchoMAX

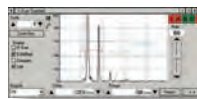

Screen update rates on digital instruments are not able to keep up with the pulse repetition frequency of high performance ultrasonic instruments. As a result, previous digital flaw detectors had difficulty displaying an alarmed defect's actual A-Scan. GE's exclusive EchoMAX technology is designed to overcome this issue and offers the ultimate in A-Scan display for reliable echo visualization by completely digitizing the A-Scan of each ultrasonic pulse. The EchoMAX uses advanced algorithms to capture and display the exact A-Scan of every alarm condition, ensuring real time visual alarm verification. The operator can be confident to never miss a shot and has the ability to pass a defect standard through at full test speed.

Multi A-Scan



With the USIP 40's Multi A-Scan feature, you can view up to ten channels of ultrasonic data on the same screen simultaneously. Each A-Scan can be controlled independently with different gain, range and delay and include up to four colored bar gates. Because each window is independent, the operator can size the A-Scan as large or small as required for easy viewing. The Multi A-Scan feature also allows you to simultaneously display two A-Scans from the same cycle using different display ranges. You can now display an overall A-Scan and zoom in to inspect details at the same time.

Multi-Cycle operation

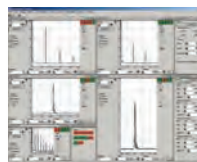

A USIP 40 can be provided with up to 10 ultrasonic channels depending on inspection needs. In addition to this channel flexibility, the USIP 40 provides up to 20 separate ultrasonic setups (cycles) to automatically drive single or multiple channels complete with DAC or TCG compensation during an inspection sequence. As each cycle is independent, gain and gate positions can be varied between cycles. This allows the operator to carry out multiple tests using a single probe.



Feature Summary

- Up to 10 ultrasonic channels
- Up to 20 kHz PRF
- Aero version qualified to GE and RRAE specifications
- Independent pulser and receiver for each channel
- 20 Programmable cycles for multi-zone inspection
- EchoMAX A-Scan display function
- View up to 10 A-Scans at once
- Available strip chart , C-Scan imaging, and TOFD weld inspection software
- Interface gate synchronizing for surface following
- Back-wall echo attenuator
- Direct 3-axis encoder input
- Automatic Gain Control
- User configurable in English, French, German, Spanish, Japanese, Chinese

Wide Fields of Application

Aerospace

The USIP 40 Aero configuration is qualified to GE DFO P3TF22, P3TF30, P3TF35, and RRAE RPS705 specifications for jet engine component inspections. USIP 40 instruments are also extensively used for airframe composite inspection by leading aircraft manufacturers.

Automotive

Used in conjunction with Ultraproof imaging software, the USIP 40 is the perfect instrument for inspecting pistons and other safety critical parts. Configured in this way, the USIP 40 provides visualization and recording of alarm outputs as well as automatic evaluation and reporting of single flaws, interacted flaws, and total numbers of flaws per part and per batch.

Pipe and tube

With the appropriate probe holders and imaging software, the USIP 40 is easily set up for weld inspection, multi-channel flaw detection and wall thickness measurement.

Plate and billet

Combining inspection productivity and coverage requires multiple inspection channels. The 10-Channel USIP 40 fills this need in both manual and automated inspection environments.

Roll testing

The multi-channel USIP 40 combined with C-Scan imaging provides rapid scanning of industrial rollers. GE's K-Scan software knits multiple ultrasonic channels to form one continuous C-Scan. In combination with the USIP 40's 20,000 Hz PRF, this package is perfect for high-speed defect evaluation and sizing.

Vessel weld inspection

Combined with Ultramap Weld software, the USIP 40 can be configured to perform multi-channel inspections of welds on pressure vessels to ASME Case 2235 utilizing both Time of Flight Diffraction (TOFD) and pulse-echo B-Scan imaging and data archiving tools.

Technical Specifications

USIP 40	
Number of Channels	Up to 10 Channels in Maximum 20 Cycles
Pulse Repetition Freq.	4 to 20000 Hz, Proportionally Divided for Each Cycle
Pulser	Spike Pulse 100 V, 400 V / Charging Capacitor, 1 nF, 220 pF / Rise Time, 10 ns
Wide-Band Filter (-3 dB)	0.2 - 30 MHz / 10 - 30 MHz / 1 - 10 MHz
Narrow-Band Filter	1 / 2.25 / 5 / 10 / 15 MHz
Gain	0 - 110 dB, in 0.5 dB Steps
Fine Gain Setting	1 dB, Continuously Variable in 10 Steps
Rectifier	Full-Wave, Negative, Positive Half-Wave, RF Mode
Reject	Linear, 0 - 80 % Screen Height
TCG	44 dB with Maximum 12 dB/ μ s
DAC/TCG	DAC or TCG with up to 16 Reference Echoes per Cycle, Multiple DAC Mode with up to Four Additional Curves at Variable Spacing from the Reference Curve, Individual Curves for Each Cycle Possible
Backwall Echo Attenuation	Full Dynamic Range of 110 dB
Sound Velocity	500m/sec - 20000m/sec (0.02 inch/sec - 0.78 "/sec)
Digital Upsampling	400 MHz, 9 bits
A-Scan Display	512 or 1024 Pixels, Range: 4.5 mm - 15 m in 0.1 mm Increments (0.1" - 590" in 0.004" Increments), Pulse Delay -10 mm - 15 m in 0.1 mm Increments (-0.4" - 590" in 0.004" Increments), Display Start with Initial Pulse or Interface Echo
Evaluation Gates	Four (Interface, A, B, C) Color Coded and Independent per Cycle, Coincidence or Anticoincidence Logic Selectable, Flaw Suppression per Counter (1 - 16), Trigger: Initial Pulse or Interface, Width 0.1 mm - 15 m in 0.1 mm Increments (0.003" - 590" in 0.004" Increments), Start 0.0 mm - 15 m in 0.1 mm Increments (0" - 590" in 0.004" Increments)
Amplitude Resolution	0.5 % of Display Range
Thickness Resolution	2.5 ns Corresponding to 0.007 mm (0.000275") at Sound Velocity of Steel
Thickness Measurement Modes	Measurements Selectable between Initial Pulse or Interface Echo and Gates A, B, or C or between Gates A and B. Start/Stop at Zero Crossing, Flank or Peak Echo Including Tolerance Monitor with 4 Thickness Values Min and Max per Cycle
Data Output	Measurement Readings Output as Max Amplitude or Min/Max Thickness Value. Alarm Output Amplitude Threshold or Min/Max Thickness Value.
Analog Outputs	10 User-Programmable for Measurement Readings (Active/Min/Max), Wall Thickness/Echo Amplitude 0 to 10 V, 12 Bit Resolution.
Alarm Outputs	16 User-Programmable for Cycle and Threshold, for Flaw Threshold via TTL (Coincidence/Anticoincidence), for Thickness Tolerance Monitor via TTL with Range Overflow and Underflow.
Test Data Release	4 User-Programmable Inputs for Each Test Channel.
Encoder Inputs	3 Inputs for Quadrature or Pulse/Direction Encoders, Compression of Ultrasonic Data on Path Grid.
Units	mm, inch, μ s
Operator Interface Languages	User Configurable in English, German, French, Spanish, Chinese and Japanese
Interconnects	Probes: Lemo 00 or BNC; RF Output: Lemo 00; I/O: 25-pin Sub D; 37-pin Sub D; Sync: 9-pin Sub D; Video: VGA Out 15-pin Sub D Rack and Portable Configuration also Include - Mouse and Keyboard: PS2 (Rack only); Serial Interface: 9-pin Sub D; 2 x USB
Network	Box with Ethernet - TCP/IP, 100 MB/s
Mains Operation	Rack and Box via Internal Power Supply (85 - 265 VAC); Power Consumption 40 W (Rack), 24 W (Box). Portable Version via External Power Supply (85 - 265 VAC), Battery Operation: Two Li-Ion Battery Packs (Hot Swap), 10.8 V, 7.2 Ah ea, 3.25 h Operation. 70 W During Charging
Operating Temperature	0 - 40° C (32 F - 104 F)
Size (HxWxD) and Weight	Rack: 310 mm x 450 mm x 375 mm (12.2" x 17.7" x 14.75") (7U), 16.5 kg (36.36 lb) Box: 125 mm x 450 mm x 430 mm (4.9" x 17.7" x 16.9") (3U), 7 kg (15.4 lb) Portable: 390 mm x 374 mm x 150 mm (15.3" x 14.7" x 5.9"), 8.2 kg (18.1lb) Incl. 2 Li-Ion Batteries

K-Scan

Multi-featured C-Scan imaging option that, when combined with the USIP 40, provides a powerful inspection tool for immersion tank, roller and other applications.

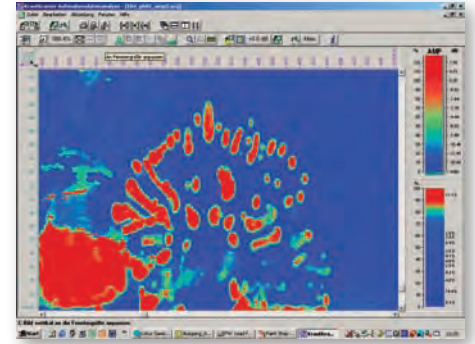

Ultraproof

Strip chart data recording, imaging and analysis option for the USIP 40 provides a series of tools for applications requiring linear scans.

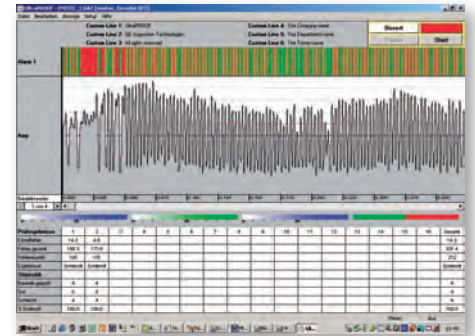

Ultramap weld

Multi-channel imaging option for the USIP 40 providing TOFD and pulse echo tools for weld inspection.

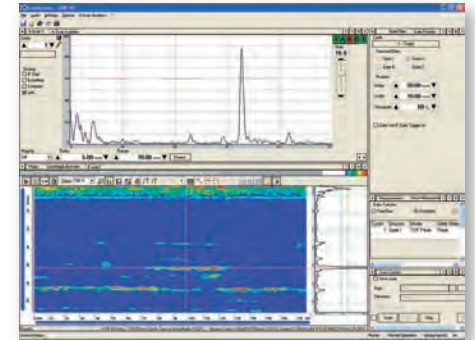

GE Inspection Technologies: productivity through inspection solutions

GE Inspection Technologies provides technology-driven inspection solutions that deliver productivity, quality and safety. We design, manufacture and service Ultrasonic, Remote Visual, Radiographic and Eddy Current equipment and systems. Offering specialized solutions that will help you improve productivity in your applications in the Aerospace, Power Generation, Oil & Gas, Automotive or Metals Industries.

Visit www.ge.com/inspectiontechnologies for more information.



Standard and Custom Ultrasonic Transducers:

- ▶ Conventional
- ▶ Phased Array
- ▶ Applications Engineering



Who We Are:

Sensor Networks, Inc. (SNI) is a Pennsylvania-based technology company specializing in the design and fabrication of industrial ultrasonic transducers and tooling for demanding in-situ test and inspection applications. Engineered for precision, ease of use, and maximum durability, our offerings include ultrasonic transducers, fixtures, couplant-delivery systems, qualification/calibration standards, procedure development, personnel training and instrumentation.

“The transducer enables and/or optimizes the UT exam.”

Ultrasonic Transducers:

- ▶ Conventional
- ▶ Phased Array
- ▶ Applications Engineering

SNI’s deep domain expertise enhances NDT solutions through the selection, design, and optimization of the ultrasonic technique. The transducers’ efficiency is paramount for converting electrical energy into sound, then coupling and directing that acoustic energy into the test piece to maximize its signal-to-noise ratio.

With an average of 21 years and an aggregate of 916 years, our experienced team of engineers, technicians, assemblers, and general managers have an extremely deep level of knowledge and background in solving unusual, demanding, and complicated NDT projects. Industries served over this time include aerospace engines and airframes, nuclear vessels, heat exchangers, large gas turbines and others.



Table of Contents

▶ Contact Transducers	4-5
- Model CR	4
- Model F Fingertip	5
▶ Delay-Line Contact Transducers	6-7
- Model DFR Fingertip	6
- Replaceable Pencil Probes	7
▶ Dual-Element Transducers	8-9
- Model ADP	8
- Model DU	9
▶ Angle-Beam Transducers	10-17
- Model AWS (Large Angle-Beam)	10
- Model SWS (Large Angle-Beam)	11-12
- Model QS (Small Angle-Beam)	13-14
- Model MSWS (Miniature Angle-Beam)	15
- Model MWB+/MWK+ (European-Style Small Angle-Beam)	16
- TOFD (Small Angle-Beam)	17
▶ Immersion Transducers	18-22
- I1	19
- I2, I3, I4	20-21
- IR	22
- Paintbrush	23
▶ Thickness Gauging Transducers	24
- Single Element	24
- Dual Element	24
- Dual-Linear Phased-Array™	24
▶ Phased Array Transducers	25-29
- Standard Transducers	25-27
- Case Diagrams and Sizing	27-29
▶ Wedges & Cables	30-31
▶ Applications Engineering & Custom Transducer Capabilities	32-34
▶ Appendix and Warranty Terms: Technical Information and PAUT Connector Type ..	35-36
▶ Contact Us	Back Cover



Contact Transducers

CR

Single-Element Contacts are longitudinal-wave (straight-beam) transducers designed for general purpose manual ultrasonic inspection where test materials are relatively flat and smooth. They provide high sensitivity for better penetration, small-flaw detection, and have abrasion-resistant wear plates for extended service life.



Model CR Standard Contact Transducers

The larger element sizes of Model CR provide greater scan widths and penetration for applications such as plate, billet, bars, thick-section parts, pipe, and tanks. They have side-mounted BNC connectors and removable comfort grip to reduce operator fatigue. **GP series*** offer the best combination of sensitivity and resolution.

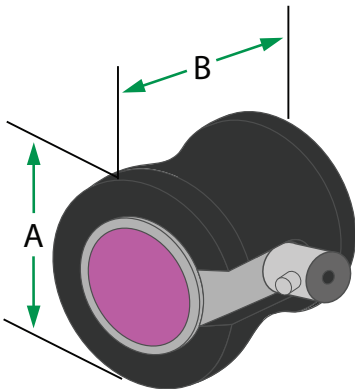

Model CR

Element Ø		A		B	
inch	mm				
0.50	12.7	1.5 in.	38.1 mm	1.3 in.	33 mm
0.75	19	1.75 in.	44.5 mm	1.3 in.	33 mm
1	25.4	2.0 in.	50.8 mm	1.4 in.	35.6 mm

Frequency (MHz)	Element Diameter		Part Number	
	inch	mm	GP	Accessories
1	0.5	12.7	00-010626	Cable BNC - BNC 6-ft (1.83 m) 07-010018
	0.75	19	00-010901	
	1	25.4	00-010902	
2.25	0.5	12.7	00-010616	
	0.75	19	00-010419	
	1	25.4	00-010416	
3.5	0.5	12.7	00-010903	
	0.75	19	00-010904	
	1	25.4	00-010905	
5	0.5	12.7	00-010617	
	0.75	19	00-010906	
	1	25.4	00-010907	
10	0.5	12.7	00-010908	

* GP = General Purpose.
 * See appendix for technical details.



Contact Transducers

F Fingertip

Single-Element Contacts are longitudinal-wave (straight-beam) transducers designed for general purpose manual ultrasonic inspection where test materials are relatively flat and smooth. They provide high sensitivity for better penetration, small-flaw detection, and have abrasion-resistant wear plates for extended service life.



Model F Fingertip Contact Transducers

Model F are small diameter transducers with side-mounted Microdot connectors. **GP series*** offer the best combination of sensitivity and resolution for most applications. **HR series*** are highly damped for applications where high resolution is required. **C series*** have piezocomposite elements and offer superior penetration in highly-attenuative materials. All Model F transducers feature an ergonomic design for improved operator control and comfort.

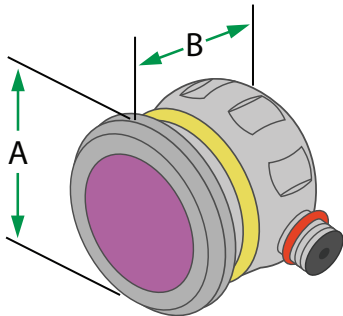

Model F Fingertip

Element Ø		A		B	
inch	mm				
0.25	6.4	0.58 in.	14.7 mm	0.66 in.	16.8 mm
0.375	9.5	0.71 in.	18 mm	0.66 in.	16.8 mm
0.50	12.7	0.83 in.	21.1 mm	0.66 in.	16.8 mm

Frequency (MHz)	Element Diameter		Part Number			Accessories
	inch	mm	GP	HR	C	
2.25	0.25	6.4	00-010612		00-011084	Cable MD - BNC 6-ft (1.83 m) 07-010012
	0.375	9.5	00-010618		00-011085	
	0.5	12.7	00-010622		00-011086	
3.5	0.25	6.4	00-010613		00-011087	
	0.375	9.5	00-010619		00-011088	
	0.5	12.7	00-010623		00-011089	
5	0.25	6.4	00-010614	00-010602	00-011090	
	0.375	9.5	00-010620	00-010606	00-011091	
	0.5	12.7	00-010624	00-010610	00-011092	
10	0.25	6.4	00-010615	00-010603		
	0.375	9.5	00-010621	00-010607		

* GP = General Purpose; HR = High Resolution; C = Composite.
 * See appendix for technical details.



Delay-Line Contact

DFR

Delay-Line Contacts are single-element, longitudinal-wave (straight beam) transducers designed for detection of near-surface flaws and thickness measurement of thin-section materials. Replaceable delay lines (stand-offs) improve near-surface resolution and extend service life.



Model DFR Fingertip Delay-Line Transducers

Model DFR are small-diameter delay-line transducers with side-mounted Microdot connectors. Removable delay lines and highly damped piezoceramic elements enable measurement of very thin parts or detection of small near-surface flaws. Delay lines can be contoured for improved coupling to I.D. or O.D. curved parts. Custom sizes and shapes also available upon request.

Model DFR

Element Ø		A		B		C	
inch	mm						
0.125	3.2	0.51 in.	13 mm	0.83 in.	21.1 mm	0.30 in.	7.6 mm
0.25	6.4	0.51 in.	13 mm	0.83 in.	21.1 mm	0.30 in.	7.6 mm
0.5	12.7	0.88 in.	22.4 mm	1.15 in.	29.2 mm	0.60 in.	15.2 mm
Mini-DFR							
0.125	3.2	0.41 in.	10.4 mm	0.77 in.	19.6 mm	0.19 in.	4.8 mm

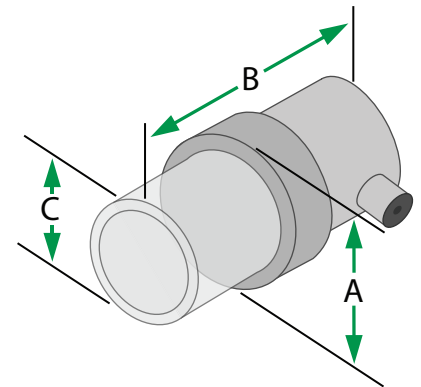

Frequency (MHz)	Element Diameter		Part Number	Delay 10-PK	Delay 10-PK	Accessories
	inch	mm	HR	L=.38 in (10mm)	L=.5 in (12.7mm)	
2.25	0.25	6.4	00-010940	01-010810	01-010811	Cable MD - BNC 6-ft (1.83 m) 07-010012
	0.5	12.7	00-012301	01-011971	01-011973	
3.5	0.25	6.4	00-010824	01-010810	01-010811	
	0.5	12.7	00-010941	01-011971	01-011973	
5	0.25	6.4	00-010246	01-010810	01-010811	
	0.5	12.7	00-010492	01-011971	01-011973	
10	0.25	6.4	00-010247	01-010810	01-010811	
	0.5	12.7	00-012302	01-011971	01-011973	
15	0.25	6.4	00-011077	01-010810	01-010811	

Frequency (MHz)	Element Diameter		Part Number	Delay 10-PK	Accessories
	inch	mm	HR	L=.41 in (10.4mm)	
Nominal 20MHz	0.125	3.2	00-012300	01-011974	See above



Delay-Line Contact

Pencil Probes

Delay-Line Contacts are single-element, longitudinal-wave (straight beam) transducers designed for detection of near-surface flaws and thickness measurement of thin-section materials. Replaceable delay lines (stand-offs) improve near-surface resolution and extend service life.



Replaceable Delay-Line Pencil Probes

Pencil probes are designed for applications requiring a very small contact face, such as curved turbine blades or thickness measurement from the inside of a pit. They can be used with most flaw detectors and precision thickness gauges. Interchangeable delay lines are tapered to tip diameters of 0.065 inch (1.7mm) and 0.090 inch (2.3mm). Replaceable delay lines are available in packs of 10. The straight model features a removable handle, which also allows it to be used as a fingertip probe. All models have Microdot connectors.

Pencil Probes

Frequency	A		B		C		D	
7.5	1.0 in.	25.4 mm	0.60 in.	15.2 mm	0.42 in.	10.7 mm	0.4 in.	10.2 mm
20	1.0 in.	25.4 mm	0.60 in.	15.2 mm	0.42 in.	10.7 mm	0.4 in.	10.2 mm

Frequency	E		F		G	
7.5	0.09 in.	2.3 mm	4.0 in.	101.6 mm	0.42 in.	10.7 mm
20	0.09 in.	2.3 mm	4.0 in.	101.6 mm	0.42 in.	10.7 mm

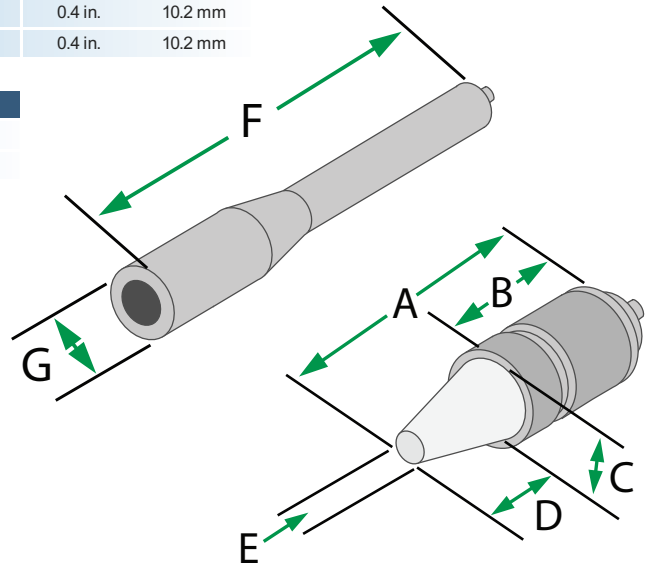

Frequency (MHz)	Part Number		
	Straight	45 Degree	90 Degree
7.5	00-011083	00-012296	00-012297
20	00-011039	00-012298	00-012299

Delay 10-PK .065" (1.7mm) Tip	Delay 10-PK .090" (2.3mm) Tip	Cable MD - BNC
00-012222	00-012221	6-ft (1.83 m) 07-010012

Extension Handle	Knurled Ring
00-012220	06-014005



Dual Element ADP

Dual-Element Contacts are longitudinal-wave (straight beam) transducers designed for near-surface and thin range flaw detection and thickness measurement. Two elements, one transmitter and one receiver, are mounted at an included (roof) angle to improve signal-to-noise ratio (SNR) and optimize near-surface resolution.



Model ADP Dual-Element Contact Transducers

Model ADP are small-diameter, low-profile transducers with 2 fixed co-axial cable and BNC connectors*. They are especially suitable for flaw detection and thickness measurement on pitted, curved, and irregular surfaces. Because the elements are mounted on internal delay lines they can be contoured to fit I.D. or O.D. curved surfaces.

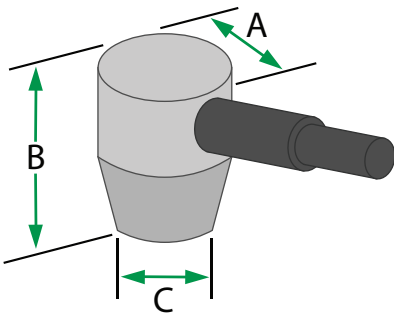

Model ADP

Element Ø		A		B		C	
inch	mm						
0.25	6.4	0.50 in.	12.7 mm	0.64 in.	16.3 mm	0.28 in.	7.1 mm
0.375	9.5	0.62 in.	15.7 mm	0.64 in.	16.3 mm	0.41 in.	10.4 mm
0.5	12.7	0.75 in.	19 mm	0.68 in.	17.3 mm	0.60 in.	15.2 mm

Frequency (MHz)	Element Diameter		Part Number
	inch	mm	C
2.25	0.25	6.4	00-011405
	0.375	9.5	00-011406
	0.5	12.7	00-011407
3.5	0.25	6.4	00-011408
	0.375	9.5	00-011409
	0.5	12.7	00-011410
5	0.25	6.4	00-010656
	0.375	9.5	00-010655
	0.5	12.7	00-011411
10	0.25	6.4	00-011412
	0.375	9.5	00-011413
	0.5	12.7	00-011414
7.5 FH2E+ Flaw	0.3	7.6	00-010532

* Also available with Lemo-00 connectors upon request.



Dual Element

DU

Dual-Element Contacts are longitudinal-wave (straight beam) transducers designed for near-surface and thin-range flaw detection and thickness measurement. Two elements, one transmitter and one receiver, are mounted at an included (roof) angle to improve signal-to-noise ratio and optimize near-surface resolution.

Model DU Dual-Element Contact Transducers

Model DU are general purpose dual-element transducers with side-mounted Microdot connectors. Replaceable/interchangeable delay lines and cross-talk barriers greatly extend versatility, cost-effectiveness, service life and can be contoured to fit I.D. or O.D. curved surfaces.

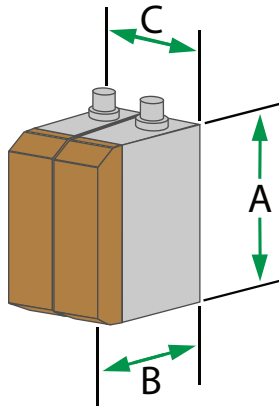

Model DU

Element Dimensions		A		B		C	
inch	mm						
0.5 x 0.5	12.7 x 12.7	0.89 in.	22.6 mm	0.92 in.	23.4 mm	0.78 in.	19.8 mm
0.5 x 1	12.7 x 25.4	1.39 in.	35.3 mm	0.92 in.	23.4 mm	0.78 in.	19.8 mm

Frequency (MHz)	Element Dimensions		Part Number		
	inch	mm	GP	Delay Set	Accessories
2.25	0.5 x 0.5	12.7 x 12.7	00-012322	01-010740	Dual Cable MD - BNC
	0.5 x 1	12.7 x 25.4	00-012323	01-010741	
5	0.5 x 0.5	12.7 x 12.7	00-010487	01-010740	6-ft (1.83 m) 07-010012
	0.5 x 1	12.7 x 25.4	00-010584	01-010741	



Large Angle Beam AWS

Angle-Beam Transducers and their wedges generate shear (transverse) waves at the specified angle in a given test material to detect flaws that cannot be detected by a straight beam transducer. Typical applications include weld inspection, tube and pipe, shafts, turbine blades and wheel rims. Shear waves are produced by refracting a longitudinal wave in a precision machined acrylic wedge that also minimizes wedge noise.



Model AWS Angle-Beam Transducers

Model AWS transducers and wedges meet the requirements of American Welding Society Structural Welding Code D1.1 and Bridge Welding Code D1.5. The transducers are available with piezoceramic elements (**GP series***) and piezocomposite elements (**C series***).

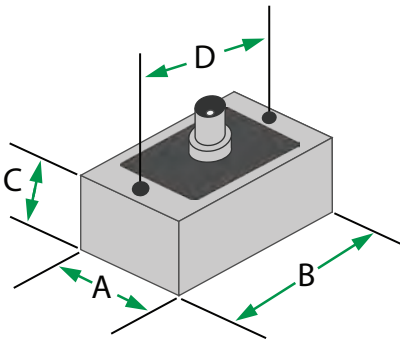

Model AWS

Element Dimensions		A		B		C		D	
inch	mm								
0.625 x 0.625	16 x 16	0.80 in.	20.3 mm	1.26 in.	32 mm	0.75 in.	19.1 mm	0.75 in.	19.1 mm
0.625 x 0.75	16 x 19	0.80 in.	20.3 mm	1.26 in.	32 mm	0.75 in.	19.1 mm	0.75 in.	19.1 mm
0.75 x 0.75	19 x 19	0.85 in.	21.6 mm	1.26 in.	32 mm	0.75 in.	19.1 mm	0.75 in.	19.1 mm
Thread									
4-40									

Frequency (MHz)	Element Dimensions		Part Number			
	inch	mm	GP	C	Wedges	Accessories
2.25	0.625 x 0.625	16 x 16	00-010393	00-010242	45° 01-010268	Cable BNC - BNC 6-ft (1.83 m) 07-010018
					60° 01-010269	
					70° 01-010270	
	0.625 x 0.75	16 x 19	00-010395	00-010394	45° 01-010268	
					60° 01-010269	
					70° 01-010270	
	0.75 x 0.75	19 x 19	00-010397	00-010396	45° 01-010268	
					60° 01-010269	
					70° 01-010270	

* GP = General Purpose; C = Composite.
* See appendix for technical details.



Large Angle Beam

SWS

Angle-Beam Transducers and their wedges generate shear (transverse) waves at the specified angle in a given test material to detect flaws that cannot be detected by a straight-beam transducer. Typical applications include weld inspection, tube and pipe, shafts, turbine blades and wheel rims. Shear waves are produced by refracting a longitudinal wave in a precision machined acrylic wedge that also minimizes wedge noise.



Model SWS Angle-Beam Transducers

Model SWS are designed for general weld inspection and other applications such as pipes, tanks, pressure vessels, forgings and castings. They have top mounted BNC connectors and are available with piezocomposite elements (**C series***). Interchangeable acrylic wedges provide maximum versatility and service life.

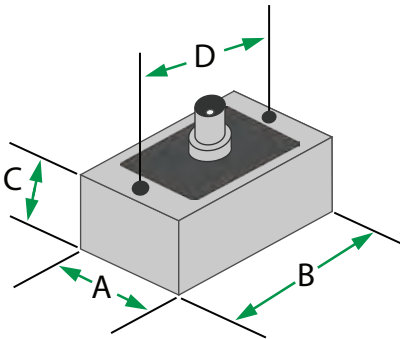

Model SWS

Element Size		A		B		C		D	
inch	mm								
0.5 Ø	12.7 Ø	0.72 in.	18.3 mm	1.0 in.	25.4 mm	0.75 in.	19 mm	0.81 in.	20.6 mm
0.5 x 1	12.7 x 25.4	0.73 in.	18.5 mm	1.5 in.	38.1 mm	0.75 in.	19 mm	1.31 in.	33.3 mm
0.75 x 1	19 x 25.4	1.0 in.	25.4 mm	1.5 in.	38.1 mm	0.75 in.	19 mm	1.31 in.	33.3 mm
1 Ø	25.4 Ø	1.22 in.	31.0 mm	1.65 in.	41.9 mm	0.75 in.	19 mm	1.38 in.	35.1 mm
									Thread
									4-40

Frequency (MHz)	Element Dimensions		Part Number		
	inch	mm	C	Wedges	Accessories
0.5	0.5 Ø	12.7 Ø	00-010478	45° 01-010206	Cable BNC - BNC 6-ft (1.83 m) 07-010018
				60° 01-010207	
				70° 01-010208	
	0.5 x 1	12.7 x 25.4	00-010479	45° 01-010210	
				60° 01-010211	
				70° 01-010212	
	0.75 x 1	19 x 25.4	00-010480	45° 01-010214	
				60° 01-010215	
				70° 01-010216	
	1 Ø	25.4 Ø	00-010481	45° 01-010218	
				60° 01-010219	
				70° 01-010220	

Chart continues on page 12

* C = Composite. See appendix for technical details.



Large Angle Beam

SWS Continued

Frequency (MHz)	Element Dimensions		Part Number		
	inch	mm	C	Wedges	Accessories
1	0.5 Ø	12.7 Ø	00-010445	45° 01-010206	
				60° 01-010207	
				70° 01-010208	
	0.5 x 1	12.7 x 25.4	00-010446	45° 01-010210	
				60° 01-010211	
				70° 01-010212	
	0.75 x 1	19 x 25.4	00-010447	45° 01-010214	
				60° 01-010215	
				70° 01-010216	
	1 Ø	25.4 Ø	00-010448	45° 01-010218	
				60° 01-010219	
				70° 01-010220	
2.25	0.5 Ø	12.7 Ø	00-010449	45° 01-010206	
				60° 01-010207	
				70° 01-010208	
	0.5 x 1	12.7 x 25.4	00-010450	45° 01-010210	
				60° 01-010211	
				70° 01-010212	
	0.75 x 1	19 x 25.4	00-010451	45° 01-010214	
				60° 01-010215	
				70° 01-010216	
	1 Ø	25.4 Ø	00-010452	45° 01-010218	
				60° 01-010219	
				70° 01-010220	
3.5	0.5 Ø	12.7 Ø	00-010453	45° 01-010206	
				60° 01-010207	
				70° 01-010208	
	0.5 x 1	12.7 x 25.4	00-010454	45° 01-010210	
				60° 01-010211	
				70° 01-010212	
	0.75 x 1	19 x 25.4	00-010455	45° 01-010214	
				60° 01-010215	
				70° 01-010216	
	1 Ø	25.4 Ø	00-010456	45° 01-010218	
				60° 01-010219	
				70° 01-010220	
5	0.5 Ø	12.7 Ø	00-010457	45° 01-010206	
				60° 01-010207	
				70° 01-010208	
	0.5 x 1	12.7 x 25.4	00-010458	45° 01-010210	
				60° 01-010211	
				70° 01-010212	
	0.75 x 1	19 x 25.4	00-010459	45° 01-010214	
				60° 01-010215	
				70° 01-010216	
	1 Ø	25.4 Ø	00-010460	45° 01-010218	
				60° 01-010219	
				70° 01-010220	

Cable
BNC - BNC
6-ft (1.83 m)
07-010018



Small Angle Beam

QS

Angle-Beam Transducers and their wedges, generate shear (transverse) waves at the specified angle in a given test material to detect flaws that cannot be detected by a straight-beam transducer. Typical applications include weld inspection, tube and pipe, shafts, turbine blades and wheel rims. Shear waves are produced by refracting a longitudinal wave in a precision-machined acrylic wedge that also minimizes wedge noise.



Model QS Angle-Beam Transducers

Model QS features Quick Swap screw-in wedge attachment. They are available with top-mounted Microdot (MD) or new MCX low-profile swivel connectors. Piezocomposite (**C series***) offer superior penetration and signal-to-noise ratio in highly-attenuative and coarse-grain materials.

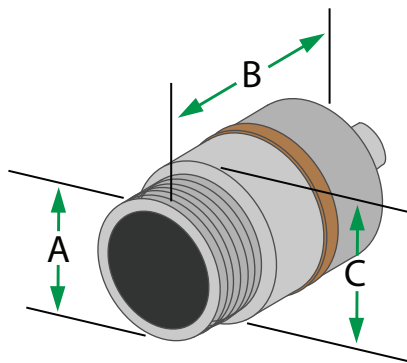

Model QS

Element Ø		A	B		C	
inch	mm		inch	mm	inch	mm
0.25	6.4	3/8 - 32 UNEF	0.58 in.	14.7 mm	0.43 in.	10.9 mm
0.375	9.5	1/2 - 28 UNEF	0.58 in.	14.7 mm	0.54 in.	13.7 mm
0.5	12.7	5/8 - 24 UNEF	0.65 in.	16.5 mm	0.69 in.	17.5 mm



MCX connectors are snap-in and can swivel, preventing the risk of back threading. (Shown above with 90° cable connector)

Frequency (MHz)	Element Diameter		Part Number			
	inch	mm	C**	Wedges	Accessories	
1	0.375	9.5	00-010137 MD or MCX	30° 01-010193	Cables	
				45° 01-010194		
				60° 01-010195		
				70° 01-010196		
	0.5	12.7	00-010138 MD or MCX	30° 01-010197		MD - BNC
				45° 01-010198		6-ft (1.83 m)
				60° 01-010199		07-010012
				70° 01-010200		
1.5	0.25	6.4	00-010216 MD or MCX	30° 01-010189	MCX - BNC	
				45° 01-010190	Straight	
				60° 01-010191	6-ft (1.83 m)	
				70° 01-010192	07-010007	
	0.375	9.5	00-010217 MD or MCX	30° 01-010193	MCX - BNC	
				45° 01-010194		Right Angle
				60° 01-010195		6-ft (1.83 m)
				70° 01-010196		07-010008
	0.5	12.7	00-010218 MD or MCX	30° 01-010197	07-010008	
				45° 01-010198		
				60° 01-010199		
				70° 01-010200		

Chart continues on page 14

* C = Composite. See appendix for technical details.

** When ordering QS transducers, please include the part number followed by the connector type (MD or MCX)



Small Angle Beam

QS Continued

Frequency (MHz)	Element Diameter		C**	Part Number	
	inch	mm		Wedges	Accessories
2.25	0.25	6.4	00-010122 MD or MCX	30° 01-010189	Cables MD - BNC 6-ft (1.83 m) 07-010012 MCX - BNC Straight 6-ft (1.83 m) 07-010007 MCX - BNC Right Angle 6-ft (1.83 m) 07-010008
				45° 01-010190	
				60° 01-010191	
	0.375	9.5	00-010123 MD or MCX	70° 01-010192	
				30° 01-010193	
				45° 01-010194	
	0.5	12.7	00-010124 MD or MCX	60° 01-010195	
				70° 01-010196	
				30° 01-010197	
3.5	0.25	6.4	00-010125 MD or MCX	45° 01-010198	
				60° 01-010199	
				70° 01-010200	
	0.375	9.5	00-010126 MD or MCX	30° 01-010189	
				45° 01-010190	
				60° 01-010191	
	0.5	12.7	00-010127 MD or MCX	70° 01-010192	
				30° 01-010193	
				45° 01-010194	
5	0.25	6.4	00-010128 MD or MCX	60° 01-010195	
				70° 01-010196	
				30° 01-010197	
	0.375	9.5	00-010129 MD or MCX	45° 01-010198	
				60° 01-010199	
				70° 01-010200	
	0.5	12.7	00-010130 MD or MCX	30° 01-010189	
				45° 01-010190	
				60° 01-010191	
7.5	0.25	6.4	00-010131 MD or MCX	70° 01-010192	
				30° 01-010193	
				45° 01-010194	
	0.375	9.5	00-010132 MD or MCX	60° 01-010195	
				70° 01-010196	
				30° 01-010197	
	0.5	12.7	00-010133 MD or MCX	45° 01-010198	
				60° 01-010199	
				70° 01-010200	
10	0.25	6.4	00-010134 MD or MCX	30° 01-010189	
				45° 01-010190	
				60° 01-010191	
	0.375	9.5	00-010135 MD or MCX	70° 01-010192	
				30° 01-010193	
				45° 01-010194	
	0.5	12.7	00-010136 MD or MCX	60° 01-010195	
				70° 01-010196	
				30° 01-010197	
				45° 01-010198	
				60° 01-010199	
				70° 01-010200	

** When ordering QS transducers, please include the part number followed by the connector type (MD or MCX)



Miniature Angle Beam MSWS

Angle-Beam Transducers and their wedges, generate shear (transverse) waves at the specified angle in a given test material to detect flaws that cannot be detected by a straight-beam transducer. Typical applications include weld inspection, tube and pipe, shafts, turbine blades and wheel rims. Shear waves are produced by refracting a longitudinal wave in a precision machined acrylic wedge that also minimizes wedge noise.

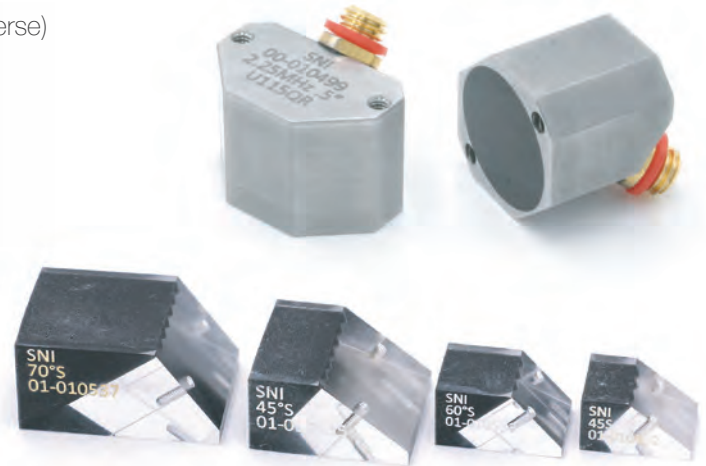

Model MSWS Angle Beam Transducers

Model MSWS have captive screws for wedge attachment and angled Microdot connectors for applications requiring low profile. Piezocomposite (**C series***) offer superior penetration and signal-to-noise ratio in highly-attenuative and coarse-grain materials.

Model MSWS

Element Ø		A		B		C		D	
inch	mm								
0.25	6.4	0.48 in.	12.2 mm	0.34 in.	8.6 mm	0.31 in.	7.9 mm	0.38 in.	9.7 mm
0.5	12.7	0.73 in.	18.5 mm	0.5 in.	12.7 mm	0.56 in.	14.2 mm	0.63 in.	16 mm
Thread									
1-64									

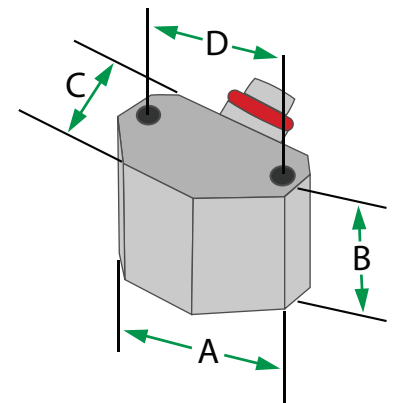

Frequency (MHz)	Element Diameter		Part Number		
	inch	mm	C	Wedges	Accessories
1	0.5	12.7	00-010497	45° 01-010535	Cable MD - BNC 6-ft (1.83 m) 07-010012
				60° 01-010536	
				70° 01-010537	
2.25	0.25	6.4	00-010498	45° 01-010532	
				60° 01-010533	
				70° 01-010534	
	0.5	12.7	00-010499	45° 01-010535	
				60° 01-010536	
				70° 01-010537	
3.5	0.25	6.4	00-010500	45° 01-010532	
				60° 01-010533	
				70° 01-010534	
	0.5	12.7	00-010501	45° 01-010535	
				60° 01-010536	
				70° 01-010537	
5	0.25	6.4	00-010502	45° 01-010532	
				60° 01-010533	
				70° 01-010534	
	0.5	12.7	00-010503	45° 01-010535	
				60° 01-010536	
				70° 01-010537	
10	0.25	6.4	00-010504	45° 01-010532	
				60° 01-010533	
				70° 01-010534	
	0.5	12.7	00-010505	45° 01-010535	
				60° 01-010536	
				70° 01-010537	

* C = Composite. See appendix for technical details.



Integral-Wedge Angle Beam

MWB+ & MWK+

European-Style Angle-Beam Transducers generate shear (transverse) waves at the specified angle in a given test material to detect flaws that cannot be detected by a straight beam transducer. Typical applications include weld inspection, tube and pipe, shafts, turbine blades and wheel rims. Shear waves are produced by refracting a longitudinal wave in a precision-machined acrylic wedge that also minimizes wedge noise.



Model MWB+/MWK+ Angle-Beam Transducers

Models MWB+ and MWK+ are small transducers with side or top-mounted Microdot connectors and integral wedges for maximum versatility. **GP series*** (MWB+) offer the best combination of sensitivity and resolution. **C series*** (MWK+) with piezocomposite elements offer superior resolution, penetration and signal-to-noise ratio in highly-attenuative and coarse-grain materials such as austenitic stainless steel or cast iron.

Model MWB+/MWK+

Element Dimensions		A		B		C	
inch	mm						
0.31 x 0.35	8 x 9	1.07 in.	27.1 mm	0.86 in.	21.8 mm	0.66 in.	16.8 mm

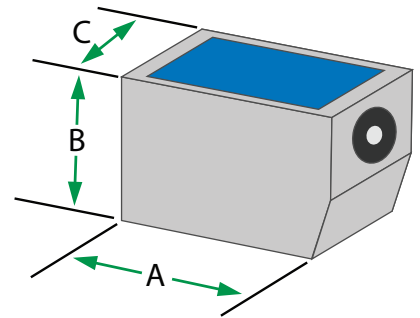

Frequency (MHz)	Element Dimensions		Angle (Steel)	Connector Location	Part Number		
	inch	mm			GP (MWB+)	C (MWK+)	Accessories
2	0.31 x 0.35	8 x 9	35	Top	00-012227	00-012306	Cables MD - BNC Straight 6-ft (1.83 m) 07-010012 MCX - BNC Straight 6-ft (1.83 m) 07-010007 MCX - BNC Right Angle 6-ft (1.83 m) 07-010008
				Side	00-012226	00-012307	
			45	Top	00-012229	00-012308	
				Side	00-012228	00-012251	
			60	Top	00-012231	00-012309	
				Side	00-012230	00-012252	
			70	Top	00-012233	00-012310	
				Side	00-012232	00-012253	
			80	Top	00-012235	00-012311	
				Side	00-012234	00-012312	
			90	Side	00-012236	00-012313	
				4	0.31 x 0.35	8 x 9	
Side	00-012237	00-012315					
45	Top	00-012240	00-012316				
	Side	00-012239	00-012248				
60	Top	00-012242	00-012317				
	Side	00-012241	00-012249				
70	Top	00-012244	00-012318				
	Side	00-012243	00-012250				
80	Top	00-012246	00-012319				
	Side	00-012245	00-012320				
90	Side	00-012247	00-012321				

* GP = General Purpose; C = Composite.
 * See appendix for technical details.



Small Angle Beam TOFD

TOFD Angle-Beam Transducers

Time-Of-Flight Diffraction (TOFD) is a method used to determine the size of cracks in metallic welds. It requires highly-damped, broadband transducers and wedges that generate refracted longitudinal waves (L-waves). SNI's TOFD transducers have state-of-the-art piezocomposite elements (**C series***) and Quick Swap screw-in wedge attachment. Straight-mounted connectors are Microdot (3/8-32) or Lemo-00 (M12 case).



TOFD Microdot

Frequency (MHz)	Element Diameter		Part Number			
	inch	mm	Connector	C	Wedges	Accessories
5	0.125	3	Microdot	00-010168	45°L 01-010475	Cables MD - BNC 6-ft (1.83 m) 07-010012
					60°L 01-010476	
					70°L 01-010477	
	0.25	6			45°L 01-010475	
					60°L 01-010476	
					70°L 01-010477	
10	0.125	3	Microdot	00-010166	45°L 01-010475	
					60°L 01-010476	
					70°L 01-010477	
	0.25	6			45°L 01-010475	
					60°L 01-010476	
					70°L 01-010477	
15	0.125	3	Microdot	00-010165	45°L 01-010475	
					60°L 01-010476	
					70°L 01-010477	

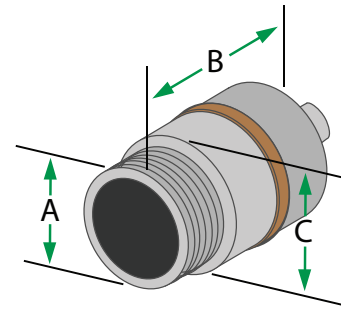

	Element Ø		
	inch mm	0.125 3	0.25 6
A		0.37 in. 9.4 mm	0.37 in. 9.4 mm
B		0.72 in. 18.3 mm	0.72 in. 18.3 mm
C		0.41 in. 10.4 mm	0.41 in. 10.4 mm

TOFD Lemo-00

Frequency (MHz)	Element Diameter		Part Number		
	inch	mm	Connector	C	Accessories
5	0.125	3	Lemo-00	00-010299	Cables Lemo-00 - BNC 6-ft (1.83 m) 07-010014
	0.25	6	Lemo-00	00-010300	
10	0.125	3	Lemo-00	00-010298	
	0.25	6	Lemo-00	00-010386	
15	0.125	3	Lemo-00	00-010631	

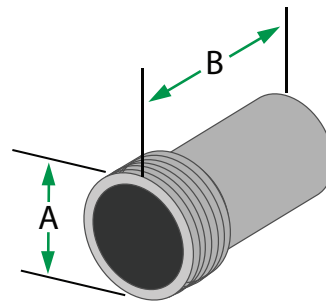

	Element Ø		
	inch mm	0.125 3	0.25 6
A		0.47 in. 12 mm	0.47 in. 12 mm
B		0.83 in. 21 mm	0.83 in. 21 mm

* C = Composite. See appendix for technical details.



Immersion Transducers

Immersion Transducers are typically used in automatic and manual scanning systems using water or other liquid as a coupling medium to enable the inspection of parts with complex geometries and with near-surface resolution superior to that of contact transducers. Spherical (point) or cylindrical (line) focusing can further improve sensitivity and resolution. Focal length must be specified.



Frequency (Mhz)		Element Ø (Inches)					
		1	0.75	0.5	0.375	0.25	0.125
1	Near	4.3	2.4	1.1			
	Min	2	1.5	1			
	Max	3	2	1			
2.25	Near	9.5	5.4	2.4	1.4	0.6	
	Min	2	1.5	1	0.8	0.5	
	Max	6	4	2	0.8	0.5	
3.5	Near	15	8.4	3.7	2.1	0.9	
	Min	2	1.5	1	0.8	0.5	
	Max	8	6	2.5	0.5	0.5	
5	Near	21	12	5.4	3	1.3	0.3
	Min	2	1.5	1	0.8	0.5	0.3
	Max	8	8	4	1	0.8	0.3
10	Near		12	10.7	6	2.7	0.7
	Min		1.5	1	0.8	0.5	0.3
	Max		8	6	4.5	1.5	0.3
15	Near			16	9	4	1
	Min			1	0.8	0.5	0.3
	Max			6	6	2	0.5
25	Near					6.7	1.7
	Min					0.5	0.3
	Max					2	1

This table lists the near-field lengths of minimum and maximum practical focal lengths in water (inches). Customers should only request focal lengths within these limits to achieve good focal performance. SNI is aware that some customers have experience with transducers focused longer than the recommended maximum (sometimes called "Beam Correction" since the transducer cannot achieve a focal point that long). These are available on a best-effort basis.

N = Near-field practical focal length
 Min = Minimum practical focal length
 Max = Maximum practical focal length

$$N = \frac{(\text{Dia.})^2 \times (\text{Freq.})}{4 \times \text{Velocity}}$$

When ordering immersion transducers, please include the part number followed by type of focus and focal length in inches (if applicable).

(ex. 00-011321 NF, 00-011321 6.0S, 00-011321 8.0C)

NF = Non-focused (flat)

S = Spherical focus

C = Cylindrical focus



Immersion

I1

Immersion Transducers are typically used in automated and manual-scanning systems using water or other liquid as a coupling medium. This enables the inspection of parts with complex geometries and near-surface resolution superior to that of contact transducers. Spherical (point) or cylindrical (line) focusing can further improve sensitivity and resolution. Focal length must be specified.



Model I1 Immersion Transducers

Model I1 are small-diameter, pencil-type transducers with straight-mounted Microdot connectors. Because the connectors are not waterproof, sealing with non-water-soluble grease is recommended. **GP series*** offer the best combination of sensitivity and resolution for general applications. **HR series*** are highly damped for applications where high resolution is required. **C series*** have piezocomposite elements and offer superior penetration, resolution and signal-to-noise ratio in highly-attenuative and coarse-grain materials.

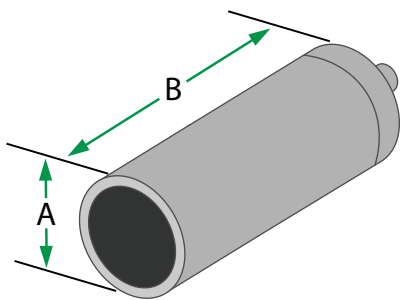

Model I1

Element Ø		A		B	
inch	mm				
0.25	6.4	0.38 in.	9.7 mm	1.25 in.	31.8 mm

Frequency (MHz)	Element Diameter		Focus	Part Number			Accessories
	inch	mm		GP	HR	C	
2.25	0.25	6.4	None	00-011300 NF	00-011301 NF	00-011302 NF	Cable MD - BNC 6-ft (1.83 m) 07-010012
			Spherical	00-011300 X.XS	00-011301 X.XS	00-011302 X.XS	
			Cylindrical	00-011300 Y.YC	00-011301 Y.YC	00-011302 Y.YC	
5	0.25	6.4	None	00-011303 NF	00-010593 NF	00-010711 NF	
			Spherical	00-011303 X.XS	00-010593 X.XS	00-010711 X.XS	
			Cylindrical	00-011303 Y.YC	00-010593 Y.YC	00-010711 Y.YC	
10	0.25	6.4	None	00-010822 NF	00-010377 NF	00-010823 NF	
			Spherical	00-010822 X.XS	00-010377 X.XS	00-010823 X.XS	
			Cylindrical	00-010822 Y.YC	00-010377 Y.YC	00-010823 Y.YC	
15	0.25	6.4	None		00-010596 NF	00-011304 NF	
			Spherical		00-010596 X.XS	00-011304 X.XS	
			Cylindrical		00-010596 Y.YC	00-011304 Y.YC	

* GP = General Purpose; HR = High Resolution; C = Composite.
* See appendix for technical details.



Immersion

I2, I3, I4

Immersion Transducers are typically used in automated and manual-scanning systems using water or other liquid as a coupling medium. This enables the inspection of parts with complex geometries and near-surface resolution superior to that of contact transducers. Spherical (point) or cylindrical (line) focusing can further improve sensitivity and resolution. Focal length must be specified.



Models I2, I3 and I4 Immersion Transducers

All model I2, I3 and I4 transducers have straight-mounted waterproof UHF connectors. Available I2 element diameters are 0.25, 0.375 and 0.5 inch (6, 10 and 13 mm). I3 have 0.75 inch (19 mm) and I4 have 1.0 inch (25 mm) element diameters. **GP series*** offer the best combination of sensitivity and resolution for general applications. **HR series*** are highly-damped for applications where high resolution is required. **C series*** have piezocomposite elements and offer superior penetration, resolution and signal-to-noise ratio in highly- attenuative and coarse-grain materials.

Frequency (MHz)	Element Diameter		Case	Focus	Part Number		
	inch	mm			GP	HR	C
1	0.75	19	I3	None	00-011201 NF		00-011313 NF
				Spherical	00-011201 X.XS		00-011313 X.XS
	Cylindrical	00-011201 Y.YC		00-011313 Y.YC			
	1	25.4	I4	None	00-011314 NF		00-010683 NF
Spherical				00-011314 X.XS		00-010683 X.XS	
Cylindrical	00-011314 Y.YC		00-010683 Y.YC				
2.25	0.25	6.4	I2	None	00-011315 NF	00-011316 NF	00-011317 NF
				Spherical	00-011315 X.XS	00-011316 X.XS	00-011317 X.XS
	Cylindrical	00-011315 Y.YC	00-011316 Y.YC	00-011317 Y.YC			
	0.375	9.5	I2	None	00-011318 NF	00-011319 NF	00-011144 NF
				Spherical	00-011318 X.XS	00-011319 X.XS	00-011144 X.XS
	Cylindrical	00-011318 YC	00-011319 Y.YC	00-011144 Y.YC			
	0.5	12.7	I2	None	00-010830 NF	00-011114 NF	00-011320 NF
				Spherical	00-010830 X.XS	00-011114 X.XS	00-011320 X.XS
	Cylindrical	00-010830 Y.YC	00-011114 Y.YC	00-011320 Y.YC			
	0.75	19	I3	None	00-011321 NF	00-011322 NF	00-011146 NF
				Spherical	00-011321 X.XS	00-011322 X.XS	00-011146 X.XS
	Cylindrical	00-011321 Y.YC	00-011322 Y.YC	00-011146 Y.YC			
1	25.4	I4	None	00-011323 NF	00-011324 NF	00-011353 NF	
			Spherical	00-011323 X.XS	00-011324 X.XS	00-011353 X.XS	
Cylindrical	00-011323 Y.YC	00-011324 Y.YC	00-011353 Y.YC				
3.5	0.25	6.4	I2	None	00-011325 NF	00-011326 NF	00-011327 NF
				Spherical	00-011325 X.XS	00-011326 X.XS	00-011327 X.XS
	Cylindrical	00-011325 Y.YC	00-011326 Y.YC	00-011327 Y.YC			
	0.375	9.5	I2	None	00-011328 NF	00-011329 NF	00-011141 NF
				Spherical	00-011328 X.XS	00-011329 X.XS	00-011141 X.XS
	Cylindrical	00-011328 Y.YC	00-011329 Y.YC	00-011141 Y.YC			
	0.5	12.7	I2	None	00-011330 NF	00-011331 NF	00-010858 NF
				Spherical	00-011330 X.XS	00-011331 X.XS	00-010858 X.XS
	Cylindrical	00-011330 Y.YC	00-011331 Y.YC	00-010858 Y.YC			
	0.75	19	I3	None	00-011332 NF	00-011333 NF	00-011334 NF
				Spherical	00-011332 X.XS	00-011333 X.XS	00-011334 X.XS
	Cylindrical	00-011332 Y.YC	00-011333 Y.YC	00-011334 Y.YC			
1	25.4	I4	None	00-011335 NF	00-011336 NF	00-010586 NF	
			Spherical	00-011335 X.XS	00-011336 X.XS	00-010586 X.XS	
Cylindrical	00-011335 Y.YC	00-011336 Y.YC	00-010586 Y.YC				

Chart continues on page 21

Velocity Testing

Frequency (MHz)	Element Diameter		Case	Focus	C
	inch	mm			
5	0.25	6.4	I2	None	00-011403
	0.375	9.5	I2	None	00-011404
	0.5	12.7	I2	None	00-010437

* GP = General Purpose; HR = High Resolution; C = Composite.
* See appendix for technical details.



Immersion

I2, I3, I4 Continued

Frequency (MHz)	Element Diameter		Case	Focus	Part Number		
	inch	mm			GP	HR	C
5	0.25	6.4	I2	None	00-011337 NF	00-011351 NF	00-011338 NF
				Spherical	00-011337 X.XS	00-011351 X.XS	00-011338 X.XS
				Cylindrical	00-011337 Y.YC	00-011351 Y.YC	00-011338 Y.YC
	0.375	9.5	I2	None	00-011339 NF	00-011340 NF	00-010679 NF
				Spherical	00-011339 X.XS	00-011340 X.XS	00-010679 X.XS
				Cylindrical	00-011339 Y.YC	00-011340 Y.YC	00-010679 Y.YC
	0.5	12.7	I2	None	00-010778 NF	00-010594 NF	00-011013 NF
				Spherical	00-010778 X.XS	00-010594 X.XS	00-011013 X.XS
				Cylindrical	00-010778 Y.YC	00-010594 Y.YC	00-011013 Y.YC
	0.75	19	I3	None	00-010585 NF	00-011341 NF	00-010868 NF
				Spherical	00-010585 X.XS	00-011341 X.XS	00-010868 X.XS
				Cylindrical	00-010585 Y.YC	00-011341 Y.YC	00-010868 Y.YC
1	25.4	I4	None	00-011152 NF	00-011350 NF	00-011153 NF	
			Spherical	00-011152 X.XS	00-011350 X.XS	00-011153 X.XS	
			Cylindrical	00-011152 Y.YC	00-011350 Y.YC	00-011153 Y.YC	
10	0.25	6.4	I2	None	00-011352 NF	00-010833 NF	00-011342 NF
				Spherical	00-011352 X.XS	00-010833 X.XS	00-011342 X.XS
				Cylindrical	00-011352 Y.YC	00-010833 Y.YC	00-011342 Y.YC
	0.375	9.5	I2	None	00-010825 NF	00-010644 NF	00-011343 NF
				Spherical	00-010825 X.XS	00-010644 X.XS	00-011343 X.XS
				Cylindrical	00-010825 Y.YC	00-010644 Y.YC	00-011343 Y.YC
	0.5	12.7	I2	None	00-010595 NF	00-011349 NF	00-011344 NF
				Spherical	00-010595 X.XS	00-011349 X.XS	00-011344 X.XS
				Cylindrical	00-010595 Y.YC	00-011349 Y.YC	00-011344 Y.YC
	0.75	19	I3	None	00-011148 NF	00-010369 NF	00-011345 NF
				Spherical	00-011148 X.XS	00-010369 X.XS	00-011345 X.XS
				Cylindrical	00-011148 Y.YC	00-010369 Y.YC	00-011345 Y.YC
15	0.25	6.4	I2	None		00-011149 NF	00-011346 NF
				Spherical		00-011149 X.XS	00-011346 X.XS
				Cylindrical		00-011149 Y.YC	00-011346 Y.YC
	0.375	9.5	I2	None		00-010597 NF	00-011347 NF
				Spherical		00-010597 X.XS	00-011347 X.XS
				Cylindrical		00-010597 Y.YC	00-011347 Y.YC
0.5	12.7	I2	None		00-010774 NF	00-011348 NF	
			Spherical		00-010774 X.XS	00-011348 X.XS	
			Cylindrical		00-010774 Y.YC	00-011348 Y.YC	

Immersion I2

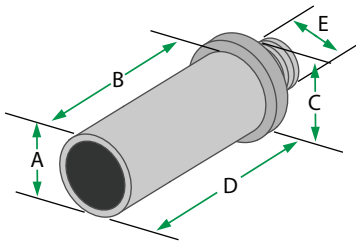

	Element Ø			
	inch mm	0.25 6.4	0.375 9.5	0.5 12.7
A		0.63 in. 16 mm	0.63 in. 16 mm	0.63 in. 16 mm
B		1.4 in. 35.6 mm	1.4 in. 35.6 mm	1.4 in. 35.6 mm
C		0.73 in. 18.5 mm	0.73 in. 18.5 mm	0.73 in. 18.5 mm
D		1.55 in. 39.4 mm	1.55 in. 39.4 mm	1.55 in. 39.4 mm
E		5/8 - 24 UNEF		

Immersion I3

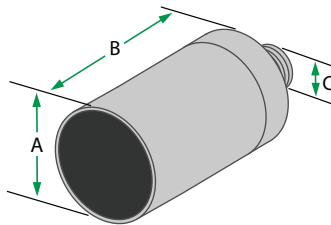

	Element Ø	
	inch mm	0.75 19
A		1.0 in. 25.4 mm
B		1.3 in. 33 mm
C		5/8 - 24 UNEF

Immersion I4

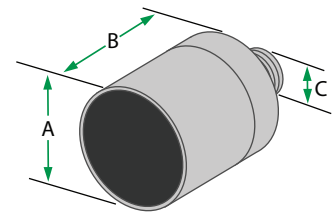

	Element Ø	
	inch mm	1 25.4
A		1.35 in. 34.3 mm
B		1.25 in. 31.8 mm
C		5/8 - 24 UNEF



Immersion

IR

Immersion Transducers are typically used in automatic and manual scanning systems using water or other liquid as a coupling medium to enable the inspection of parts with complex geometries and near-surface resolution superior to that of contact transducers. Spherical (point) or cylindrical (line) focusing can further improve sensitivity and resolution. Focal length must be specified.



Models IR Immersion Transducers

Model IR transducers have right-angle-mounted waterproof UHF connectors and small case design for applications where space is limited. Available element diameters are 0.25, 0.375 and 0.5 inch (6, 10 and 13 mm). **GP series*** offer the best combination of sensitivity and resolution for general applications. **HR series*** are highly damped for applications where high resolution is required. **C series*** have piezocomposite elements and offer superior penetration, resolution and signal-to-noise ratio in highly attenuative and coarse grain materials.

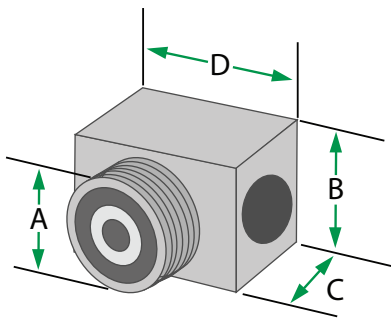

Immersion IR

Element Ø		A	B	C	D
inch	mm				
0.25	6.4	5/8 - 24 UNEF	0.75 in. 19 mm	0.75 in. 19 mm	0.94 in. 23.9 mm
0.375	9.5	5/8 - 24 UNEF	0.75 in. 19 mm	0.75 in. 19 mm	0.94 in. 23.9 mm
0.5	12.7	5/8 - 24 UNEF	0.75 in. 19 mm	0.75 in. 19 mm	0.94 in. 23.9 mm

Frequency (MHz)	Element Diameter		Focus	Part Number		
	inch	mm		GP	HR	C
2.25	0.25	6.4	None	00-011385 NF	00-011386 NF	00-011387 NF
			Spherical	00-011385 X.XS	00-011386 X.XS	00-011387 X.XS
			Cylindrical	00-011385 Y.YC	00-011386 Y.YC	00-011387 Y.YC
	0.375	9.5	None	00-011388 NF	00-011389 NF	00-011390 NF
			Spherical	00-011388 X.XS	00-011389 X.XS	00-011390 X.XS
			Cylindrical	00-011388 Y.YC	00-011389 Y.YC	00-011390 Y.YC
0.5	12.7	None	00-011391 NF	00-011392 NF	00-011393 NF	
		Spherical	00-011391 X.XS	00-011392 X.XS	00-011393 X.XS	
		Cylindrical	00-011391 Y.YC	00-011392 Y.YC	00-011393 Y.YC	
5	0.25	6.4	None	00-011394 NF	00-011395 NF	00-011396 NF
			Spherical	00-011394 X.XS	00-011395 X.XS	00-011396 X.XS
			Cylindrical	00-011394 Y.YC	00-011395 Y.YC	00-011396 Y.YC
	0.375	9.5	None	00-011397 NF	00-011398 NF	00-011399 NF
			Spherical	00-011397 X.XS	00-011398 X.XS	00-011399 X.XS
			Cylindrical	00-011397 Y.YC	00-011398 Y.YC	00-011399 Y.YC
	0.5	12.7	None	00-011400 NF	00-011401 NF	00-011402 NF
			Spherical	00-011400 X.XS	00-011401 X.XS	00-011402 X.XS
			Cylindrical	00-011400 Y.YC	00-011401 Y.YC	00-011402 Y.YC

Velocity Testing

Frequency (MHz)	Element Diameter		Focus	C
	inch	mm		
5	0.25	6.4	None	00-010591
	0.375	9.5	None	00-010438
	0.5	12.7	None	00-010475

* GP = General Purpose; HR = High Resolution; C = Composite.
* See appendix for technical details.



Immersion Paintbrush

Paintbrush Transducers

are single-element immersion transducers which give a greater scanning width than conventional transducers with round or rectangular elements. They are often used in scanning tanks where large plates, bars, and other parts are tested which have large surface areas. Their large coverage decreases scan time dramatically. Like other conventional probes, they can be ordered with GP*, HR* or C* performance and are available in flat or cylindrical focuses.



Frequency (MHz)	Element Dimensions		Focus	Part Number
	Short Axis	Long Axis		HR
10	0.25 in (6.4 mm)	2.5 in (63.5 mm)	Flat	00-010590 NF
			Cylindrical	00-010590 Y.YC

Element Dimensions		H	L	W
inch	mm			
0.25 x 2.5	6.4 x 63.5	0.65 in. 16.5 mm	2.85 in. 72.4 mm	0.75 in. 19 mm

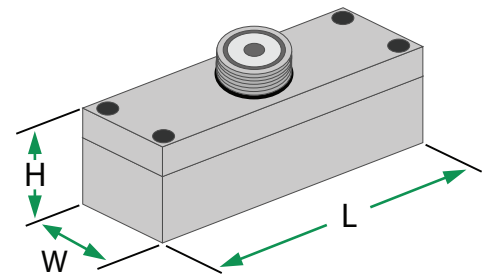

Frequency (MHz)	Element Dimensions		Focus	Part Number
	Short Axis	Long Axis		HR
10	0.25 in (6.4 mm)	1 in (25.4 mm)	Flat	00-010175 NF
			Cylindrical	00-010175 Y.YC

Element Dimensions		H	W	L
inch	mm			
0.25 x 1	6.4 x 25.4	0.95 in. 24.1 mm	0.75 in. 19 mm	1.5 in. 38.1 mm

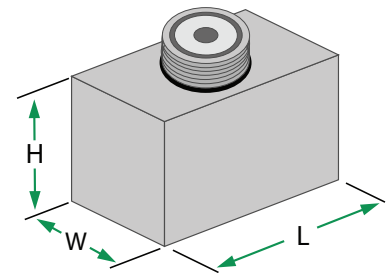

The majority of paintbrush transducers are built to specific customer requirements. These are a few examples of SNI Paintbrush Transducers but do not represent our full capabilities. Please contact us for specific probe requests.

* GP = General Purpose; HR = High Resolution; C = Composite.
* See appendix for technical details.



Thickness

Single Element, Dual Element, Phased Array

Precision (Single Element) Thickness Gauging Transducers

For use with commercial thickness gauges and flaw detection instruments.

Model	Transducer Type	Contact Diameter		Measuring Range in Steel	Nominal Frequency	SNI Part Number
		inch	mm			
Alpha2 DFR Plus	Delay Line Removable	0.3	7.6	0.007 to 1 inch 0.18 to 25.4 mm	15 MHz	00-010417
CA211 Plus	Standard Contact	0.75	19	0.60 to 20 inch 1.5 to 508 mm	5 MHz	00-010415
Alpha2 F Plus	Small Contact	0.38	9.7	0.60 to 10 inch 1.5 to 254 mm	10 MHz	00-010625
Alpha2 Mini DFR Plus	Thin Range Delay Line	0.19	4.8	0.005 to 0.2 inch 0.13 to 5.1 mm	20 MHz	00-010589
Pencil Probe	Delay Line Pencil Case	0.065 or 0.090	1.7 or 2.3	0.008 to 0.175 inch 0.20 to 0.44 mm	20 MHz	00-011039



Corrosion (Dual Element) Thickness Gauging Transducers

For use with commercial corrosion thickness gauges and flaw detection instruments.

Model	Transducer Type	Contact Diameter		Measuring Range in Steel	Temperature Maximum	SNI Part Number
		inch	mm			
FH2E Plus	Fingertip	0.38	9.7	0.030 to 2.0 inch 7.6 to 50.8 mm	<130° F <54° C	00-010424
FH2E Plus WR	Fingertip Wear Resistant	0.55	14	0.030 to 2.0 inch 7.6 to 50.8 mm	<130° F <54° C	00-010565
FH2E Plus MD	Fingertip	0.38	9.7	0.030 to 2.0 inch 7.6 to 50.8 mm	<130° F <54° C	00-011017
FH2E Plus M	Fingertip Small Diameter	0.28	7.1	0.030 to 1.0 inch 7.6 to 25.4 mm	<130° F <54° C	00-010675
FH2E Plus with BNC	Fingertip	0.38	9.7	0.030 to 2.0 inch 7.6 to 50.8 mm	<130° F <54° C	00-010532
FH2E Plus BT	Studded Boiler Tube	0.38	9.7	0.060 to 2.0 inch 1.5 to 50.8 mm	<130° F <54° C	00-010676
DA 512 Plus	Fingertip	0.295	7.5	0.024 to 2.4 inch .6 to 61 mm	<130° F <54° C	00-010638
SNI 525	Potted Fingertip	0.2	5	0.025 to 2 inch .6 to 50.8 mm	<130° F <54° C	00-012223



Dual-Linear Phased-Array™ for Corrosion Inspection

Frequency (MHz)	Number of Elements	Element Pitch		Elevation		Array Description and Application	SNI Part Number	Case
		in	mm	in	mm			
5	32 Transmit 32 Receive	0.060	1.50	0.20	5	Dual linear, corrosion inspection	00-010863	Corrosion
5	32 Transmit 32 Receive	0.030	0.75	0.20	5	Dual linear, corrosion inspection	00-011200	Corrosion





Phased Array

Standard Models

Phased Array Transducers*

SNI's phased array transducers are available in many configurations, including linear, matrix, dual matrix, curved, annular and annular sectorial. Standard cable length is 8.2-ft (2.5 m) with ZPAC, IPEX, Phasor, Mentor, or Hypertronics connector. Other cable lengths and connectors are available upon request.

General Purpose

Frequency (MHz)	Number of Elements	Element Pitch		Elevation		Array Description and Application	SNI Part Number**	Case
		inch	mm	inch	mm			
1.5	16	0.040	1.00	0.47	12	Low-frequency linear, coarse-grain materials	00-010276	E2
2.25	16	0.030	0.75	0.47	12	General purpose linear	00-010265	AM
2.25	16	0.030	0.75	0.47	12	General purpose linear	00-011419	A1
2.25	16	0.060	1.50	0.75	19	General purpose linear	00-010277	E3
2.25	64	0.024	0.60	0.38	10	General purpose linear	00-010267	LM
2.25	64	0.024	0.60	0.38	10	General purpose linear	00-011420	A12
2.25	64	0.030	0.75	0.47	12	General purpose linear	00-011421	A2
4	16	0.020	0.50	0.35	9	General purpose linear	00-010275	E1
5	16	0.024	0.60	0.38	10	General purpose linear	00-010266	AM
5	16	0.024	0.60	0.38	10	General purpose linear	00-011422	A10
5	16	0.024	0.60	0.38	10	General purpose linear	00-011423	A1
5	32	0.024	0.60	0.38	10	General purpose linear	00-010329	A11
5	64	0.024	0.60	0.38	10	General purpose linear	00-010268	LM
5	64	0.024	0.60	0.38	10	General purpose linear	00-011426	A12
5	64	0.024	0.60	0.38	10	General purpose linear	00-011427	A2
10	32	0.012	0.31	0.28	7	General purpose linear	00-011429	A10
10	32	0.012	0.31	0.28	7	General purpose linear	00-011430	A1
10	64	0.024	0.60	0.38	10	General purpose linear	00-010269	LM

Immersion

Frequency (MHz)	Number of Elements	Element Pitch		Elevation		Array Description and Application	SNI Part Number**	Case
		in	mm	in	mm			
3.5	64	0.040	1.00	0.28	7	Near wall linear immersion (elements close end)	00-010331	Near Wall
5	64	0.040	1.00	0.28	7	Near wall linear immersion (elements close end)	00-010332	Near Wall
5	128	0.030	0.75	0.38	10	Linear immersion	00-010333	I3
5	64	0.024	0.60	0.38	10	Linear immersion	00-011431	I1
5	128	0.024	0.60	0.38	10	Linear immersion	00-011432	I2
5	32	0.052	1.32	0.24	6	Curved array for composite radius inspection	00-010334	R4
5	64	0.050	1.27	0.31	8	Hardwater linear (minimizes water gap needed)	00-010327	HW

Deep Penetration

Frequency (MHz)	Number of Elements	Element Pitch		Elevation		Array Description and Application	SNI Part Number**	Case
		in	mm	in	mm			
1.5	16	0.110	2.80	1.02	26	Deep penetration probes	00-011416	A4
2.25	16	0.080	2.00	1.26	32	Deep penetration probes	00-011417	A4
2.25	32	0.030	0.75	0.94	24	Deep penetration probes	00-011418	A5
5	32	0.024	0.60	0.76	20	Deep penetration probes	00-011424	A5

* See page 36 for phased-array transducer connector types.

** When ordering phased-array transducers, please include the part number followed by the desired connector type (ex. 00-010328 ZPAC).



Phased Array

Standard Models

Small Footprint

Frequency (MHz)	Number of Elements	Element Pitch		Elevation		Array Description and Application	SNI Part Number**	Case
		in	mm	in	mm			
2.25	32	0.016	0.40	0.50	12.7	Miniature angle beam; fits conventional wedges	00-010340	.5 in. MSWS
3.5	32	0.016	0.40	0.50	12.7	General purpose linear	00-010381	.5 in. MSWS
3.5	16	0.016	0.40	0.25	6.25	General purpose linear	00-010379	.25 in. MSWS
5	16	0.016	0.40	0.25	6.25	General purpose linear	00-010380	.25 in. MSWS
5	32	0.016	0.40	0.50	12.7	Miniature angle beam; fits conventional wedges	00-010339	.5 in. MSWS
7.5	16	0.016	0.40	0.25	6.25	General purpose linear	00-010867	.25 in. MSWS
10	16	0.012	0.31	0.20	5	Small footprint, high frequency linear	00-010341	A00
10	16	0.016	0.40	0.25	6.25	General purpose linear	00-011207	.25 in. MSWS
10	32	0.016	0.40	0.50	12.7	Miniature angle beam; fits conventional wedges	00-010338	.5 in. MSWS

Wedge Mount

Frequency (MHz)	Number of Elements	Element Pitch		Elevation		Array Description and Application	SNI Part Number**	Case
		inch	mm	inch	mm			
2	8	0.040	1.00	0.35	9	Low-frequency linear, coarse-grain materials	00-010274	E1

Matrix (2D)

Frequency (MHz)	Number of Elements	Element Pitch		Elevation		Array Description and Application	SNI Part Number**	Case
		in	mm	in	mm			
1.5	2x15 5x3 element	0.150	3.80	0.16	4	Dual matrix (T/R) - coarse-grain materials	00-010278	E4
2	2x32 16x2 element	0.070	1.75	0.16	4	Dual matrix (T/R) - coarse-grain materials	00-010342	E5

Low Profile

Frequency (MHz)	Number of Elements	Element Pitch		Elevation		Array Description and Application	SNI Part Number**	Case
		in	mm	in	mm			
5	16	0.020	0.50	0.38	10	Low-profile linear	00-011211	Cobra
7.5	16	0.020	0.50	0.38	10	Low-profile linear	00-011212	Cobra
7.5	32	0.010	0.25	0.38	10	Low-profile linear	00-011213	Cobra
10	16	0.020	0.50	0.38	10	Low-profile linear	00-010214	Cobra
10	32	0.010	0.25	0.38	10	Low-profile linear	00-010215	Cobra

* See page 36 for phased-array transducer connector types.

** When ordering phased-array transducers, please include the part number followed by the desired connector type (ex. 00-010328 ZPAC).



Phased Array

Standard Models & Size Diagrams

Pipeline Probe

Frequency (MHz)	Number of Elements	Element Pitch		Elevation		Array Description and Application	SNI Part Number**	Case
		in	mm	in	mm			
5	60	0.040	1.00	0.38	10	General purpose linear	00-011425	A14
7.5	60	0.040	1.00	0.38	10	General purpose linear	00-011428	A14

Weld Inspection

Frequency (MHz)	Number of Elements	Element Pitch		Elevation		Array Description and Application	SNI Part Number**	Case
		in	mm	in	mm			
2.25	16	0.040	1.00	0.63	16	AWS linear	00-010477	AWS

A1

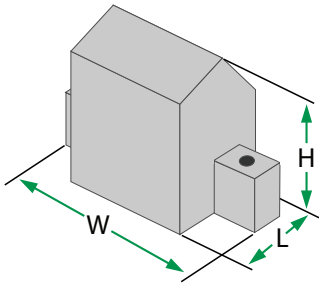

A2

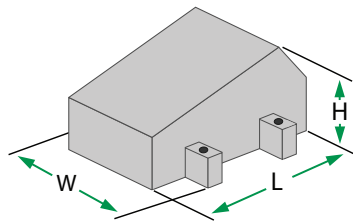

A4

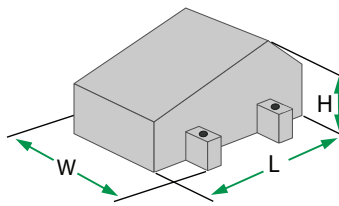

A5

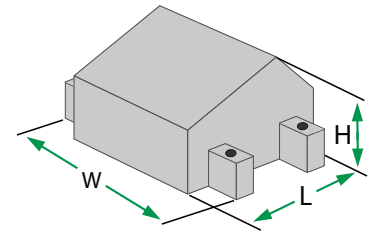

A10

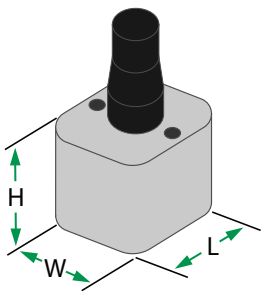

A11

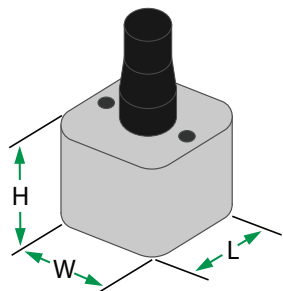

A12

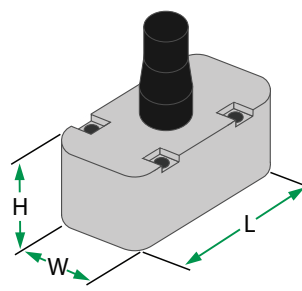

A14

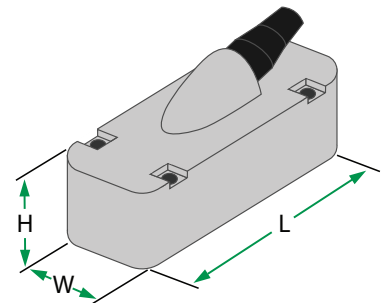

A00

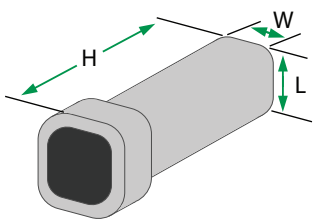

R4

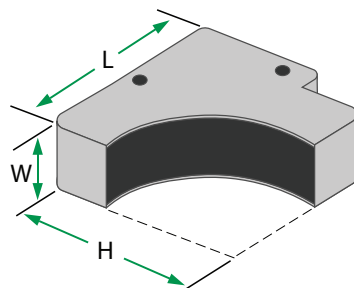

Case Type	Case Dimensions					
	Length		Width		Height	
A1	0.67 in.	17 mm	1.14 in.	29 mm	0.98 in.	24.9 mm
A2	2.09 in.	53.1 mm	1.14 in.	29 mm	1.38 in.	35.1 mm
A4	2.24 in.	56.9 mm	1.81 in.	46 mm	1.18 in.	30 mm
A5	1.14 in.	29 mm	1.69 in.	42.9 mm	0.94 in.	23.9 mm
A10	0.91 in.	23.1 mm	0.63 in.	16 mm	0.79 in.	20.1 mm
A11	0.98 in.	24.9 mm	0.91 in.	23.1 mm	0.79 in.	20.1 mm
A12	1.77 in.	45 mm	0.91 in.	23.1 mm	0.79 in.	20.1 mm
A14	2.67 in.	67.8 mm	0.91 in.	23.1 mm	0.79 in.	20.1 mm
A00	0.31 in.	7.9 mm	0.31 in.	7.9 mm	0.91 in.	23.1 mm
R4	1.67 in.	45.2 mm	0.59 in.	15 mm	1.67 in.	42.4 mm



Phased Array

Case Dimensions

E1

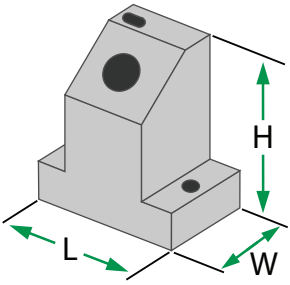

E2

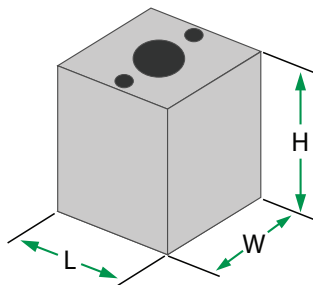

E3

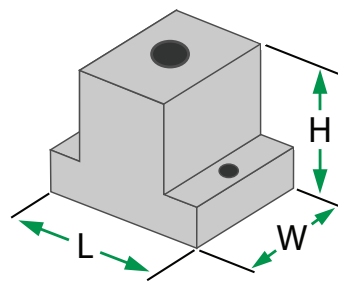

E4

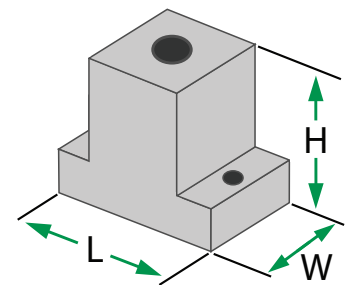

E5

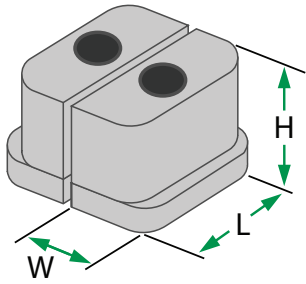

I1

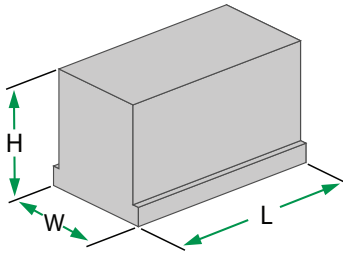

I2

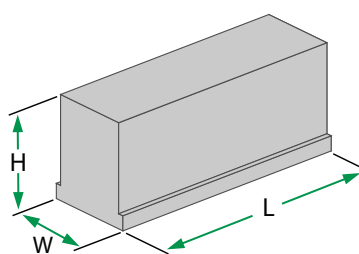

I3

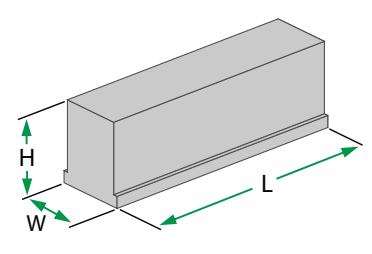

AM

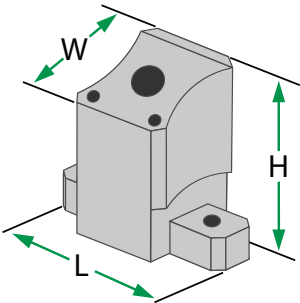

LM

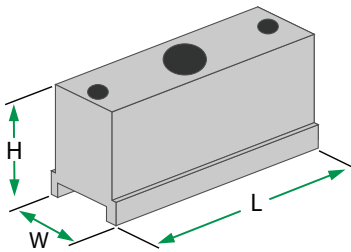

0.25 MSWS

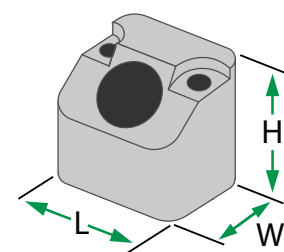

0.5 MSWS

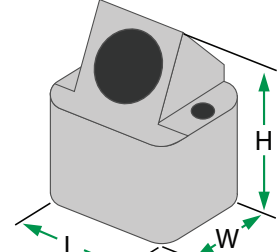

Near Wall

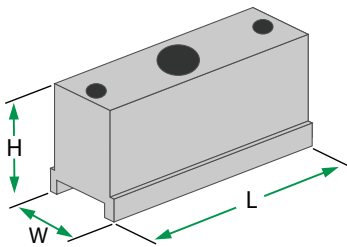

HW

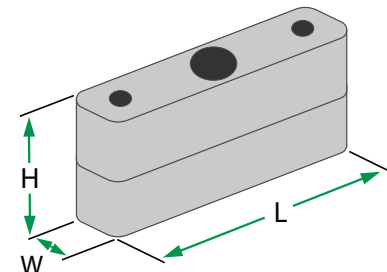

Case Type	Case Dimensions					
	Length		Width		Height	
E1	1.1 in.	27.9 mm	0.59 in.	15 mm	1.06 in.	26.9 mm
E2	0.75 in.	19 mm	0.75 in.	19 mm	1.0 in.	25.4 mm
E3	1.45 in.	36.8 mm	1.25 in.	31.8 mm	1.0 in.	25.4 mm
E4	1.33 in.	33.8 mm	0.65 in.	16.5 mm	1.0 in.	25.4 mm
E5	1.41 in.	35.8 mm	.62 in.	15.7 mm	1.0 in.	25.4 mm
I1	1.97 in.	50 mm	0.75 in.	19 mm	0.98 in.	24.9 mm
I2	3.27 in.	83.1 mm	0.83 in.	21.1 mm	1.38 in.	35.1 mm
I3	4.02 in.	102.1 mm	0.83 in.	21.1 mm	1.38 in.	35.1 mm
AM	1.18 in.	30 mm	0.63 in.	16 mm	0.98 in.	24.9 mm
LM	1.69 in.	42.9 mm	1.1 in.	27.9 mm	0.98 in.	24.9 mm
0.25 MSWS	0.5 in.	12.7 mm	0.37 in.	9.4 mm	0.5 in.	12.7 mm
0.5 MSWS	0.76 in.	19.3 mm	0.61 in.	15.5 mm	0.75 in.	19 mm
Near Wall	2.6 in.	66 mm	0.75 in.	19 mm	0.98 in.	24.9 mm
HW	3.4 in.	86.4 mm	0.5 in.	12.7 mm	1.25 in.	31.8 mm



Phased Array

Case Dimensions

Corrosion

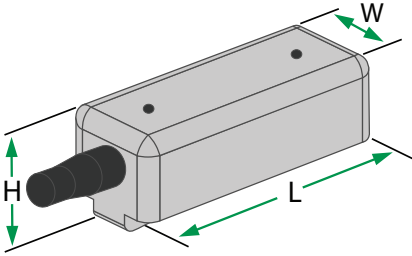

AWS

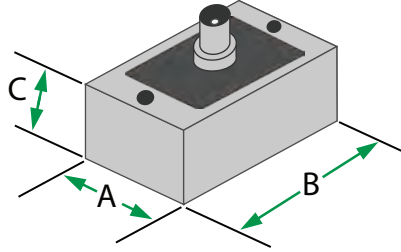

Cobra

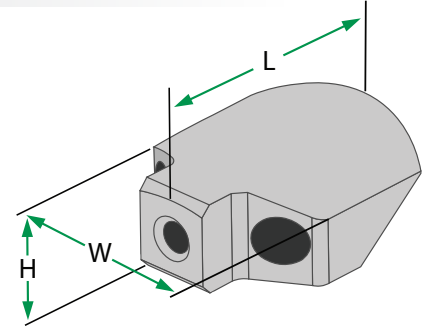

Case Type	Case Dimensions					
	Length		Width		Height	
Corrosion	2.58 in.	65.5 mm	1.0 in.	25.4 mm	0.95 in.	24.1 mm
AWS	1.26 in.	32 mm	0.80 in.	20.3 mm	0.75 in.	19 mm
Cobra	0.98 in.	24.9 mm	0.87 in.	22.1 mm	0.39 in.	9.9 mm



Accessories

Standard Wedges & Cables

Standard Wedges

Transducer Type	Element Dimensions		Wedges
	inch	mm	
AWS	0.625 x 0.625	16 x 16	45° 01-010268
			60° 01-010269
			70° 01-010270
SWS	0.5 Ø	12.7 Ø	45° 01-010206
			60° 01-010207
			70° 01-010208
	0.5 x 1	12.7 x 25.4	45° 01-010210
			60° 01-010211
			70° 01-010212
	0.75 x 1	19 x 25.4	45° 01-010214
			60° 01-010215
			70° 01-010216
	1 Ø	25.4 Ø	45° 01-010218
			60° 01-010219
			70° 01-010220

Transducer Type	Element Dimensions		Wedges
	inch	mm	
QS	0.25	6.4	30° 01-010189
			45° 01-010190
			60° 01-010191
			70° 01-010192
	0.375	9.5	30° 01-010193
			45° 01-010194
			60° 01-010195
			70° 01-010196
	0.5	12.7	30° 01-010197
			45° 01-010198
			60° 01-010199
			70° 01-010200
MSWS	0.25	6.4	45° 01-010532
			60° 01-010533
			70° 01-010534
	0.5	12.7	45° 01-010535
			60° 01-010536
			70° 01-010537
TOFD	0.125	3.2	45°L 01-010475
			60°L 01-010476
			70°L 01-010477
	0.25	6.4	45°L 01-010475
			60°L 01-010476
			70°L 01-010477

Cables

Cable	Material	Length	Part Number
BNC - BNC	RG58	6-ft (1.83 m)	07-010018
BNC - MD	RG174 TPR	6-ft (1.83 m)	07-010012
BNC - MCX	RG174 TPR	6-ft (1.83 m)	07-010007
BNC - 00-Lemo	RG174 TPR	6-ft (1.83 m)	07-010014
00-Lemo - MD	RG174 TPR	6-ft (1.83 m)	07-010028
00-Lemo - 00-Lemo	RG174 TPR	6-ft (1.83 m)	07-010034

Cable	Material	Length	Part Number
00-Lemo - MCX	RG174 TPR	6-ft (1.83 m)	07-010035
00-Lemo - MCX (RA)	RG174 TPR	6-ft (1.83 m)	07-010008
Dual BNC - Dual MD	RG174 TPR	6-ft (1.83 m)	07-010030
Dual 00-Lemo - Dual MD	RG174 TPR	6-ft (1.83 m)	07-010032
Lemo 1 - MD	RG174 TPR	6-ft (1.83 m)	07-020175
Lemo 1 - BNC	RG174 TPR	6-ft (1.83 m)	07-020176



Accessories

Phased-Array Wedges

Phased-Array Wedges

SNI's proprietary **Low-Noise-Blue™** damping material minimizes wedge noise for improved resolution and signal-to-noise ratio.

Type	Description	Part Number
E1	Wedge, REX, 38.0 DEG INC, Flat, A	01-010293
E1	Wedge, REX, 38.0 DEG INC, Flat, B	01-010294
E1	Wedge, 30-70 Shear	01-011731
E2	Wedge, REX, 38.0 DEG INC, Flat, A	01-010295
E2	Wedge, REX, 38.0 DEG INC, Flat, B	01-010296
E3	Wedge, REX, 38.0 DEG INC, Flat	01-010297
E4	Wedge, Dual, REX, 18.0 DEG INC, Flat	01-010298
E5	Wedge, Dual 18 INC 2.3RF, REX, Flat	01-010035
MSWS 1/2	Wedge, .5" MSWS, 45S, Plex	01-010535
MSWS 1/2	Wedge, .5" MSWS, 60S, Plex	01-010536
MSWS 1/2	Wedge, .5" MSWS, 70S, Plex	01-010537
MSWS 1/2	Wedge, .50" MSWS PA, REX, 35-75 SW, Flat	01-011015
MSWS 1/2	Wedge, .50" MSWS PA, REX, 35-75 L-WAVE, Flat	01-011016
AM	Wedge 40-70L, AM Case	01-010531
AM	Wedge 40-70S, AM Case	01-010703
AM	Wedge 0 Degree, AM Case	01-011975
LM	Wedge 0 Degree, LM Case	01-010706
LM	Wedge 40-70S, LM Case	01-010707
LM	Wedge 40-70L, LM Case	01-010708
A00	Wedge 30-60S, A00 Case	01-010710
A00	Wedge 45-70S, A00 Case	01-010711
A1	Wedge 0 Degree, A1 Case	01-011733
A1	Wedge 45-70 Shear, A1 Case	01-011734
A2	Wedge 0 Degree, A2 Case	01-011741
A2	Wedge 30-70 Shear, A2 Case	01-011742
A4	Wedge 0 Degree, A4 Case	01-011743
A4	Wedge 30-70 Shear, A4 Case	01-011744
A5	Wedge 0 Degree, A5 Case	01-011745
A5	Wedge 30-70 Shear, A5 Case	01-011746
A10	Wedge 0 Degree, A10 Case	01-011735
A10	Wedge 30-70 Shear, A10 Case	01-010944
A11	Wedge 0 Degree, A11 Case	01-011749
A11	Wedge 30-70 Shear, A11 Case	01-010709
A12	Wedge 0 Degree, A12 Case	01-011737
A12	Wedge 30-70 Shear, A12 Case	01-011738
A14	Wedge 0 Degree, A14 Case	01-011739
A14	Wedge 30-70 Shear, A14 Case	01-011740
A31	Wedge 30-70 Shear, A31 Case	01-010943
MSWS 1/4"	Wedge, .25" MSWS PA, REX, 35-75 SW, Flat	01-010705
MSWS 1/4"	Wedge, .25" MSWS PA, REX, 35-75 L-WAVE, Flat	01-010977
MSWS 1/4"	Wedge, .25" MSWS, 45S, Plex	01-010532
MSWS 1/4"	Wedge, .25" MSWS, 60S, Plex	01-010533
MSWS 1/4"	Wedge, .25" MSWS, 70S, Plex	01-010534
Cobra	Low profile wedge, fits Cobra Style Prbs, Flat	01-011229
Cobra	Low profile wedge, fits Cobra Style Prbs, Curved to Customer request	01-011230-XX



Applications Engineering

Custom Transducer Capabilities

Successful Ultrasonic Applications Engineering

is the result of three major elements:

- ▶ Experience
- ▶ Capabilities
- ▶ Process



Our Process

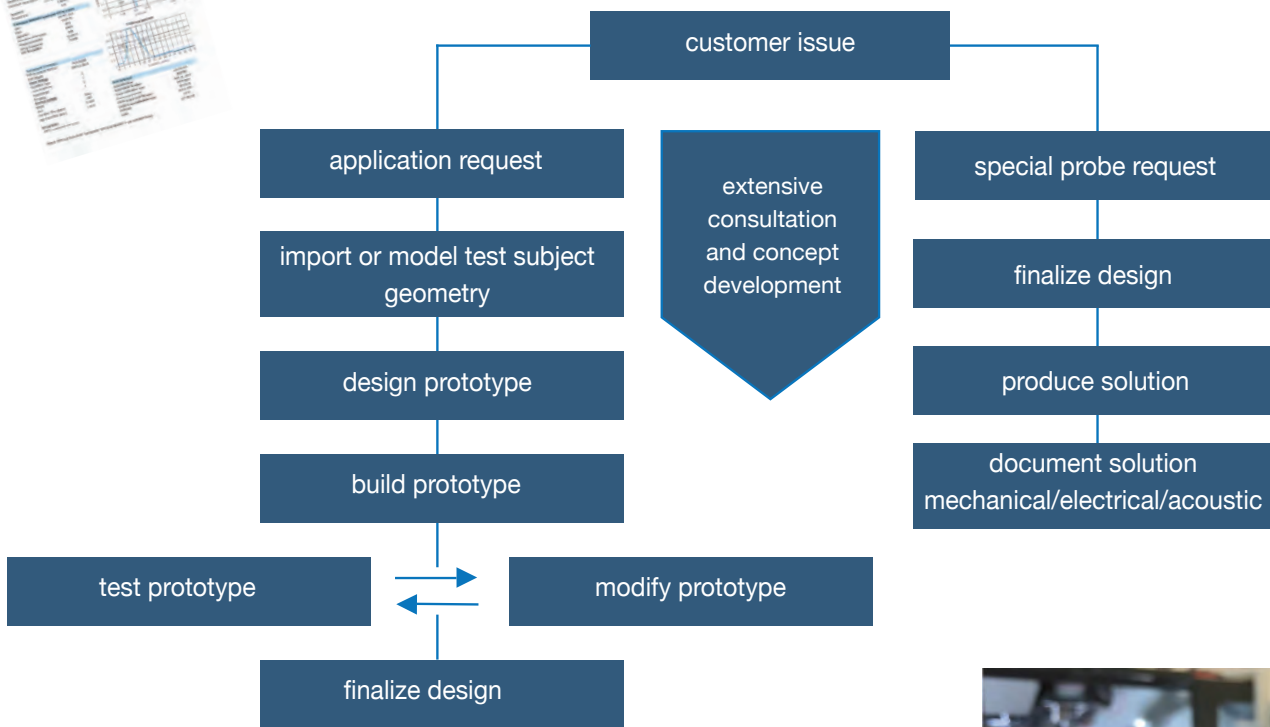

SNI's customers have direct access to our highly experienced team of NDT professionals.



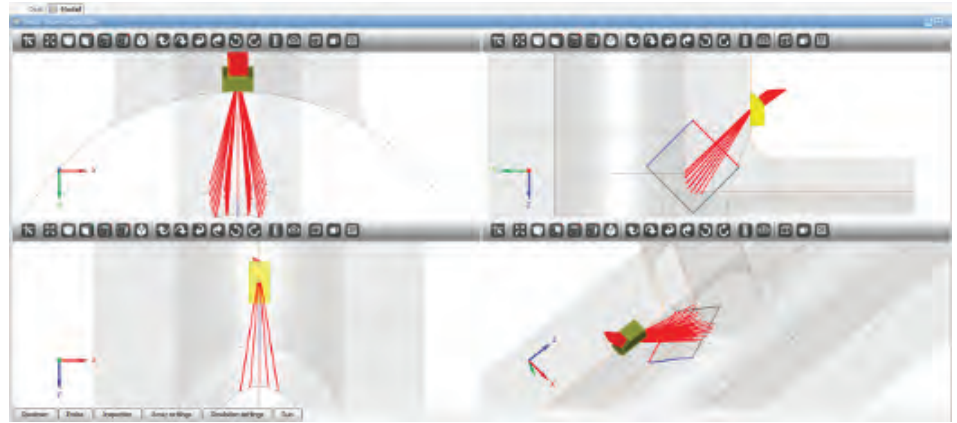
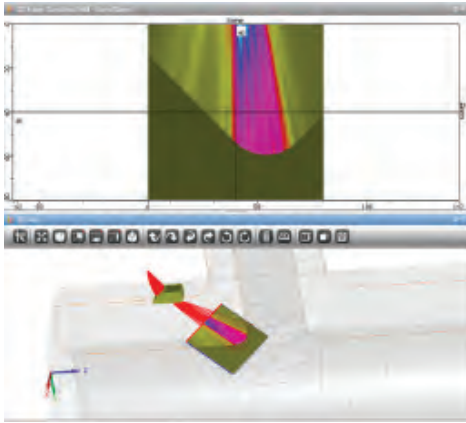

In-house CAD/CAM capabilities, including our 5-axis CNC Mill and CNC Lathe, allows for rapid prototyping of complex shapes in most engineering materials.

In-house ceramic fabrication capabilities enable rapid prototyping of complex, piezo-composite materials. This capability creates a fast and efficient project turn around.

Sensor Networks, Inc. uses industry-preferred design and simulation tools to create an optimized mechanical, electrical, and ultrasonic model of the inspection task, including its scan plan.

- ▶ **SolidWorks:** Parametric 3D CAD and Mechanical Properties Modeling
- ▶ **AutoCad:** 2D CAD and Ray-Tracing
- ▶ **CIVA:** Acoustic Beam Modeling and Delay Law Calculation for Conventional and Phased Arrays
- ▶ **PiezoCad:** Transducer Construction and Performance Modeling
- ▶ **Field II:** Transducer Construction and Performance Modeling
- ▶ **UltraVision 3D:** NDT Data Imaging and Analysis Software for Conventional and Phased Arrays
- ▶ **ES Beam Tool:** Ultrasonic Inspection Plan Design and Validation Software



Precision fixturing is key to reproducible test results

Optimized Solutions for Cost-Effective Productivity

Sensor Networks offers transducers and UT solutions in a variety of styles, compatible with any major manufacturer's conventional or phased-array instruments.



Small Diameter (<0.25"/6mm) ID Bore Probes: shear-wave, L-wave, duals and tandem types.



SensorScan® QS: conventional transducers for the quick swapping onto delay lines or wedges.



ASME Section XI: compound radius wedges, refracted longitudinal, phased array duals, contact or immersion, TOFD, complex wedges & delays.



O.D. Transducers: for tube weld or braze joints.

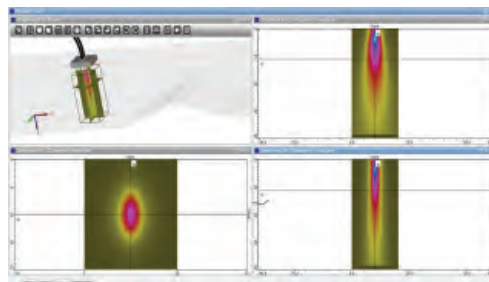

CIVA of Dual: Acoustic modeling of dual-element transducer performance on a small pit.



In-Situ: self aligning wand transducers for the hard to access rotating equipment.



Phased Array: linear & matrix, annular, daisy & circular, contact & immersion, single & dual, flat & curved.



2MHz PAUT Dual: with 2x16 elements per probe and detachable wedge.



7MHz Ultra High-Temp Delay Line: transducer and mounting clamp for continuous 500°C (932°F).



10MHz PAUT Dual: special 64-element dual for HTHA exams.



1.5MHz PAUT: replaceable wear face on 64-element phased-array Matrix probe.



5MHz PAUT: 92-element transducer for bar testing machines.



Appendix

High Resolution Series

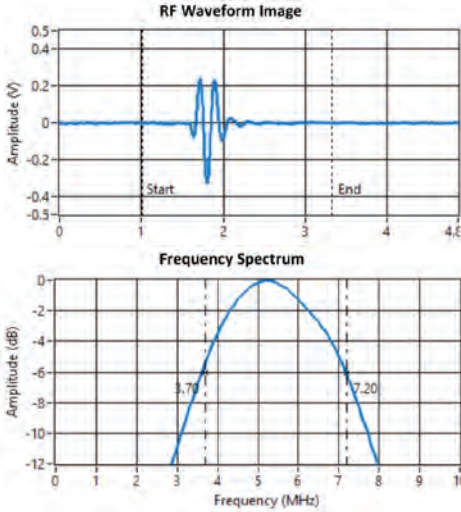

HR: High Resolution Series of transducers are highly damped and recommended for applications where enhanced axial and near-surface resolution are more important. Generally includes thickness measurement and near-surface flaw detection. HR series have less sensitivity than the GP or C series with -6db frequency bandwidth of 50-100% range.

General Purpose Series

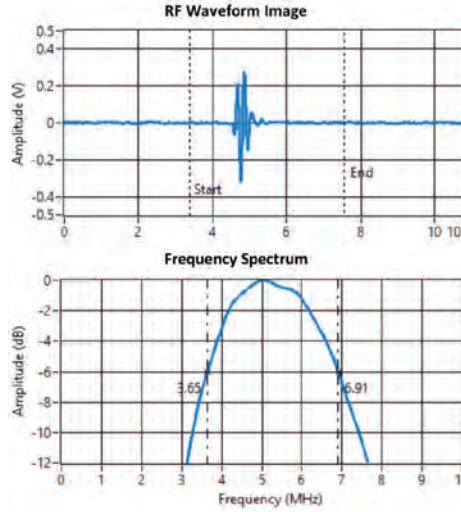

GP: General Purpose Series of transducers are recommended for most applications and have a good trade-off between sensitivity and resolution. They have a medium frequency bandwidth of 30-40% at -6db but with more ring-down cycles in the waveform.

Composite or Piezo-composite Series

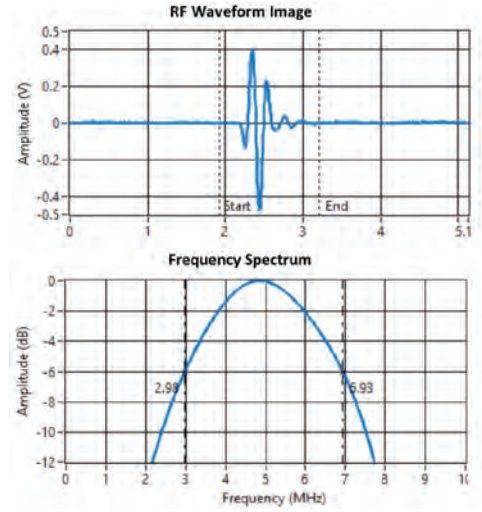

C: Composite (Piezocomposite) Series of transducers have superior sensitivity and penetration especially in highly-attenuative materials. C Series have both higher resolution, sensitivity, and have wide bandwidth (60-120% at -6db) due to the lower acoustic impedance of the material. They couple more efficiently into plastic wedges, delay lines, and water.

Ultrasonic Transducer Certification



Phone: 814-466-7207
Website: www.sensornetworksinc.com

Transducer Information	
*Part Number:	00-010778NF
*Serial Number:	778PRETESTK2
Transducer Description:	H2-5MHz; 50"-GP-NF-UHF
Frequency:	5MHz
Element Size:	50"
Transducer Measurements per ASTM E1065	
Date:	Jun 4, 2018
Time:	6:44 PM
Operator:	DEH
**Transducer Disposition:	PASS
Relative Sensitivity:	68dB
Center Frequency:	5.37MHz
-6dB Bandwidth:	67.66%

Test Setup & Conditions	
Test Procedure Number:	Tp
Test Object:	3" H2O-SST
Pulser Settings	
Repetition Rate:	4
Pulse Amplitude:	5
Pulse Energy:	2 - LowZ
Damping:	9

Receiver Settings	
Mode:	Pulse Echo
Gain:	10 + 1
Low Pass Filter (MHz):	35 MHz
High Pass Filter (MHz):	1 MHz

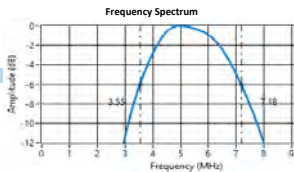
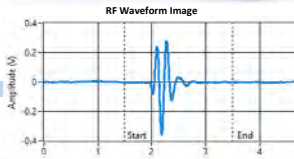

Test Equipment	
Pulser/Receiver:	IDPR300
Pulser Serial Number:	DA0901
Pulser Calibration Due Date:	Dec 14, 2018
Oscilloscope Model:	DPO2022B
Oscilloscope Serial Number:	C030032
Oscilloscope Calibration Due Date:	Oct 12, 2018
Software:	1.2.0
Cable:	6FT RG-58

*Please reference Transducer Part Number and Serial Number in any correspondence

Ultrasonic Beam Profile



Phone: 814-466-7207
Website: www.installedensors.com

Transducer Information	
*Part Number:	XDCR100N
*Serial Number:	U11CA7
Transducer Description:	XDCR 100, 75" DIA, 5 MHz, 2.3" CXL, FCS, 11A-1967_B CASE
Frequency:	5MHz
Element Size:	.75"
Transducer Measurements per ASTM E1065	
Date:	Jun 4, 2019
Time:	10:18 AM
Operator:	KPR
Transducer Disposition:	PASS
-3dB Beam length (in):	0.505"

Test Setup & Conditions	
Test Procedure Number:	
Test Object:	1/4" SST ROD
Water Path (in):	3.0"
Pulser Settings	
Repetition Rate:	4
Pulse Amplitude:	5
Pulse Energy:	2 - LowZ
Damping:	9
Receiver Settings	
Mode:	Pulse Echo
Gain:	20 + 2
Low Pass Filter (MHz):	35 MHz
High Pass Filter (MHz):	1 MHz

Special Notes:

*Please reference Transducer Part Number and Serial Number in any correspondence

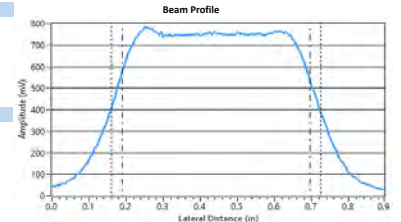

Test Equipment	
Pulser/Receiver:	JSR DPR300
Pulser Serial Number:	DA0901
Pulser Calibration Date:	Dec 19, 2019
Oscilloscope Model:	DPO2022B
Oscilloscope Serial Number:	C030032
Oscilloscope Calibration Date:	Oct 11, 2019
Software:	1.0.3
Cable:	6FT RG-58



Appendix

▶ Phased-Array Transducer Connector Types

SNI can build any phased-array transducer with:



Phasor

Mentor



(L to R) IPEX, ZPAC, Hypertronics

Linear Phased Array Ultrasonic Transducer Certification



176-500 Technology Drive
Boalsburg, PA 16827
Phone: 814-466-7207
Website: www.sensornetworksinc.com

Transducer Information

*Part Number: 00-010848
*Serial Number: U11795

Parameter	Measurement	Specification	RESULT
Average Center Freq	9.8	+/-10%	PASS
Average Bandwidth	66.3	>=60%	PASS
Sensitivity deviation	1	+/-3dB	PASS
Probe Wiring Configuration Check			PASS
Probe Cable/Connector Check			PASS

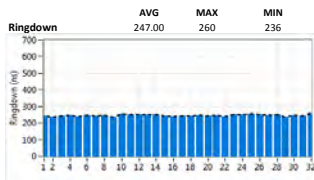
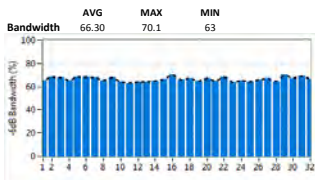
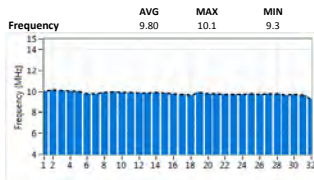
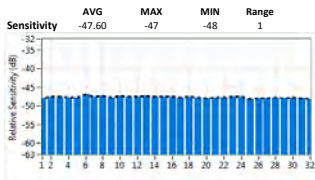

*Please reference Transducer Part Number and Serial Number in any correspondence

Linear Phased Array Ultrasonic Transducer Certification



176-500 Technology Drive
Boalsburg, PA 16827
Phone: 814-466-7207
Website: www.sensornetworksinc.com

Transducer Information

*Part Number: 00-010536-SMT
*Serial Number: U115CV
Transducer Description: 5MHz, 28EL, 1.6mmP X 10mm, 30m CBL, Rectangular

Probe Type: Rectangular
Housing: 5.0MHz
Element Pitch: 1.6 mm
Element Elevation: 10 mm
Number of Elements: 28
Cable Jacket: PU
Cable Length: 30M
Connector Type: SAMTEC

Transducer Measurements per ASTM E1065

Date: 6/13/2018
Time: 9:20:55AM
Operator: KYLE RYAN
**Transducer Disposition: PASS

Average Relative Sensitivity: -45dB
Average Center Frequency: 4.89MHz
Average -6dB Bandwidth: 78.70%

Test Setup & Conditions

Test Procedure Number: TP
Test Object: 20mm REX BW
Pulse Width: 100ns
Pulse Voltage: -12.3V

Image of Transducer



Typical RF Waveform and Frequency Spectrum (Element 14)

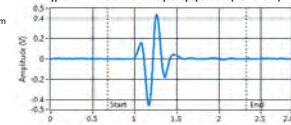

Frequency Spectrum

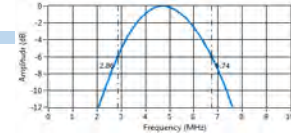

Test Equipment

Acquisition Unit: TC3
Acq. Unit Serial Number: 17054368
Acq. Unit Calibration Due Date: April 06, 2019
Hardware Version: 1.1
Software: 1.2.1
Adapter: 07-020155

Special Notes:

*Please reference Transducer Part Number and Serial Number in any correspondence

**This item was manufactured and tested according to product specific parameters. The "Pass" Disposition confirms that all steps in the manufacturing process were completed satisfactorily and that all test requirements were satisfied.

All SensorScan® Transducers carry a one-year warranty from the date of purchase, for the original owner, covering defects in materials and workmanship.

Ultrasonic Probes

Ultrasonics



Table of Contents

	Page		Page
Transducer Performance		High Temperature Dual Element Transducers	
Alpha Series Features	4	HT400A (to 1000° F)	17
Benchmark Series Features	4	KBA560V (to 750° F)	17
Gamma Series Features	4	Standard Dual Element Transducers	
Frequency Color Coding	4	DU Style (Replaceable Delay)	18
Contact Transducers		DU-F Style, Benchmark Series	18
RHP Style Standard	5	FAST™ Probes	18
XLC Style Extended Life	5	Immersion Transducers	
F Style Fingertip	6	ISS/IS Styles	19
Delay Line Contact Transducers		IPS/IR Styles	20
DFR Style Removable Delay	6	Velocity System Transducers	21
K-PEN Pencil Type Probe	7	Near Field and Focusing Information	21
ZIP Probes	7	Thickness Gauging Transducers	
Protective Face Contact Transducers		Precision Gauging	22
PFCR/PFCS Combination Styles	8	Dual Element Corrosion Gauging	23
PMCR/PMCS Membrane Styles	9	Special Probes and Applications Laboratory	
PWCCR/PWCCS Styles	10	Special Probes & Applications	24
Angle Beam Transducers		Phased Array Transducers	25
SWS/AWS Styles, Gamma	11	Accessories	
SWS/AWS Styles, Benchmark	12	Cables/Adaptors/Search Tubes	26
Miniature Angle Beam Transducers		Couplants	27
MSW-QC Quick Change, Gamma	13	Test Blocks	28
MSW-QC, Alpha & Benchmark	14	Transducer Certification	30
MSWS Style (Captive Screws)	15	Tables and Formulas	31
ABFP Style (Potted Wedge)	16	Transducer Kits	32
SMSWS Style (Subminiature)	16	Inquiry Form	34
Fingertip Dual Element Transducers			
ADP Style (Potted Cable)	17		
RC Dual Style (Replaceable Cable)	17		
FDU Style (Replaceable Cable)	17		

Transducer Performance

GE Inspection Technologies offers three series of transducers: **Alpha**, **Gamma**, and new **Benchmark**. To determine which of these series is best for your application, please read the technical information on this page. If you need assistance, contact one of our Transducer Product Specialists (717-242-0327) or your local sales representative.

Real time waveform and frequency certification is included with every transducer at no charge (refer to the Technical Information section for details).

Alpha Series Features

- Recommended for applications where resolution is the primary consideration.
- Suitable for applications such as thickness measurement and near-surface flaw detection.
- Very short pulse—mechanically damped to the limit of current technology.
- Gain is usually lower than that of the Gamma and Benchmark Series.
- Broadband—typical 6 dB bandwidths range from 50% to 100%.
- Typical Alpha waveforms (right) exhibit one to two full ring cycles, depending on frequency, size and other parameters.

Benchmark Series Features

- Proprietary **BENCHMARK COMPOSITE**[®] (piezocomposite) active elements.
- Penetration in attenuative materials is far superior to conventional transducers.
- High signal to noise on coarse grain metals, fiber reinforced composites, et al.
- Short pulse—resolution usually superior to Gamma Series.
- Gain is usually higher than that of the Gamma and Alpha Series.
- Very broadband—typical 6 dB bandwidths range from 60% to 120%.
- Low acoustic impedance element improves performance of angle beam, delay line, and immersion probes—excellent match to plastic and water.

Gamma Series Features

- General purpose transducers, recommended for the majority of applications.
- Medium pulse, medium damping—best combination of gain and resolution.
- Matching electrical network ensures maximum gain and optimum waveform for general use.
- Medium bandwidth—typical 6 dB bandwidths range from 30% to 50%.
- Typical Gamma waveform exhibits three to four full ring cycles, depending on frequency, size and other parameters.

Frequency Color Coding

For easy identification of frequency, most GE Inspection Technologies transducers are color coded as follows:

Frequency (MHz)	.50	1.0	2.25	3.50	5.00	10.00
Color	Gray	Red	Yellow	Blue	Green	Black

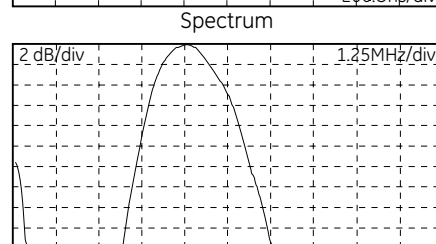
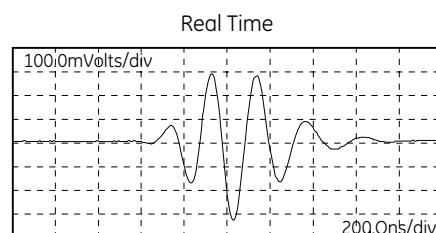
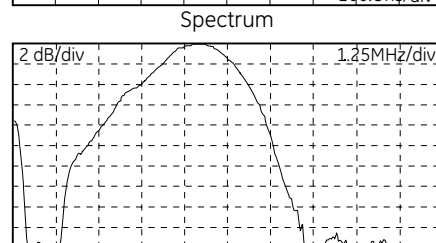
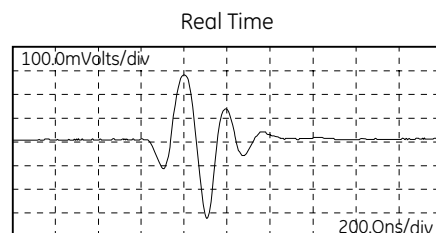
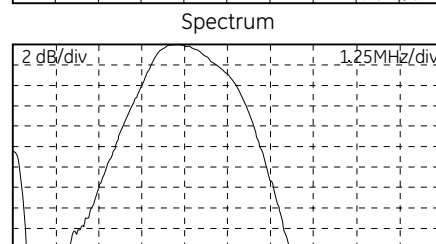
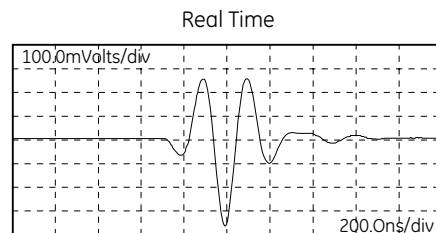

Contact Transducers

Single Element Contact Transducers are longitudinal wave transducers designed for general purpose manual ultrasonic inspection where test materials are relatively flat and smooth. Contact transducers provide high sensitivity for better penetration and are ruggedly constructed for extended service life under the roughest testing conditions.

RHP and XLC Style Contacts

Standard Contact Transducers are designed for abusive "scrubbing" applications. Gamma series are for applications where sensitivity and penetration are essential. Alpha series have maximum bandwidth for axial resolution. RHP style probes feature ceramic wearplates for the best combination of acoustic matching and durability and stainless steel housings to resist corrosion. New XLC (Extended Life Contact) style probes have special, high durability wearplates for the most abusive applications. Both styles feature an improved comfort grip and color band for frequency identification. CR models have right angle mounted BNC connectors and the CS models have top-mounted BNC connectors.

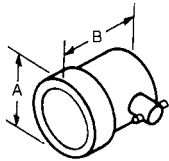

Element Ø	A	B
.500	1.15	1.50
.750	1.40	1.50
1.000	1.65	1.50

Standard Contact Transducers—RHP and XLC Styles

Freq. (MHz)	Size (in.)	Product Codes				Freq. (MHz)	Size (in.)	Product Codes			
		Style	Alpha Series	Gamma Series	Accessories			Style	Alpha Series	Gamma Series	Accessories
.5	.750	RHP		250-043-CR	Cables 6' BNC C-016 6' LEMO C-018	.500	RHP		243-043-CR	Cables 6' BNC C-016 6' LEMO C-018	
		RHP		250-123-CS			RHP		243-123-CS		
	1.00	RHP		260-043-CR			RHP		243-050-CR		
		RHP		260-123-CS			XLC		243-150-CS		
1.0	.500	RHP		241-043-CR		3.5	.750	RHP			253-043-CR
		RHP		241-123-CS				RHP			253-123-CS
	.750	RHP		251-043-CR			XLC		253-050-CR		
		RHP		251-123-CS			XLC		253-150-CS		
	1.00	RHP		261-043-CR			RHP		263-043-CR		
		RHP		261-123-CS			RHP		263-123-CS		
		XLC		261-050-CR			XLC		263-050-CR		
		XLC		261-150-CS			XLC		263-150-CS		
2.25	.500	RHP	142-043-CR	242-043-CR	5.0	.500	RHP	144-043-CR	244-043-CR		
		RHP	142-123-CS	242-123-CS			RHP	144-123-CS	244-123-CS		
		XLC		242-050-CR			RHP	154-043-CR	254-043-CR		
		XLC		242-150-CS			RHP	154-123-CS	254-123-CS		
	.750	RHP	152-043-CR	252-043-CR		1.00	RHP	164-043-CR	264-043-CR		
		RHP	152-123-CS	252-123-CS			RHP	164-123-CS	264-123-CS		
		XLC		252-050-CR			10.0	.500	RHP		246-043-CR
		XLC		252-150-CS					RHP		246-123-CS
	1.00	RHP	162-043-CR	262-043-CR							
		RHP	162-123-CS	262-123-CS							
	XLC		262-050-CR								
	XLC		262-150-CS								

Contact Transducers

Single Element Contact Transducers are longitudinal wave transducers designed for general purpose manual ultrasonic inspection where test materials are relatively flat and smooth. Contact transducers provide high sensitivity for better penetration and are ruggedly constructed for extended service life under the roughest testing conditions.



F Style Contact

F Style Contact transducers are small diameter fingertip probes with a right angle mounted Microdot connector. Gamma Series are recommended for applications where high sensitivity and penetration are essential. Alpha Series are designed for optimum damping and resolution. Benchmark Series, with Benchmark Composite® elements, are best for punching through highly attenuative materials.

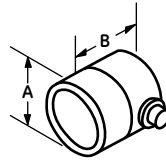

Element Ø	A	B
.250	.50	.66
.375	.63	.66
.500	.75	.66

Fingertip Contact Transducers—F Style

Freq. (MHz)	Size (in.)	Product Codes				Accessories	Freq. (MHz)	Size (in.)	Product Codes			Accessories
		Benchmark Series	Alpha Series	Gamma Series					Benchmark Series	Alpha Series	Gamma Series	
2.25	.250	822-000	122-000	222-000	Cables	5.0	.250	824-000	124-000	224-000	Cables	
	.375	832-000	132-000	232-000			.375	834-000	134-000	234-000		
	.500	842-000	142-000	242-000			.500	844-000	144-000	244-000		
3.5	.250		123-000	223-000	6' BNC C-012	10.0	.250		126-000	226-000	6' BNC C-012	
	.375		133-000	233-000			.375		136-000	236-000		
	.500		143-000	243-000			.500		146-000	246-000		
					6' LEMO C-022							

DFR Style Removable Delay Line Contact

DFR Style Removable Delay Line Fingertip Transducers are specifically designed for thickness gauging and flaw detection of thin materials. High frequency and critical damping results in a high performance transducer, which exhibits excellent resolution capability. All DFR Style Transducers have right angle mounted Microdot connectors.



Removable Delay Line—DFR Style

Freq. (MHz)	Size (in.)	Product Codes			Accessories
		Alpha Series	Delay Line 10-PK .38" Lg	Delay Line 10-PK .5" Lg	
2.25	.250	122-660	D-050	D-051	Cables
	.500	140-500		D-052	
3.5	.250	123-660	D-050	D-051	6' BNC C-012
	.500	144-660	D-050	D-051	
5.0	.250	124-660	D-050	D-051	6' LEMO C-022
	.500	144-660	D-050	D-052	
10.0	.250	126-660	D-050	D-051	Delay Line Couplant XD-740
	.500	140-602		D-052	
15.0	.250	127-660	D-050	D-051	Spring Loaded VEE Block H-007*
22.0	.125	118-660	D-050	D-051	
Mini-DFR 20.0	.125	518-650	MD-502		

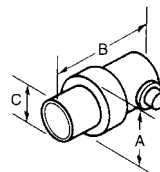

Element Ø	A	B	C
.125 or .250	.51	.835	.30
.500	.875	1.375	.595
Mini-DFR			
.125	.41	.765	.19

*H-007 fits .125" and .25" units only with exception of Mini DFR.

Contact Transducers

Single Element Contact Transducers are longitudinal wave transducers designed for general purpose manual ultrasonic inspection where test materials are relatively flat and smooth. Contact transducers provide high sensitivity for better penetration and are ruggedly constructed for extended service life under the roughest testing conditions.

K-PEN Replaceable Delay Line Pencil Probe

K-PEN's are high resolution pencil type probes. They are designed for applications requiring an extremely small contact area, such as tightly curved surfaces of turbine blades or remaining wall thickness measurements from a pit bottom. They can be used with most flaw detectors, precision thickness gauges, and general pulser / receiver units. Probes come with interchangeable delay tips that are tapered to a .065" and .090" contact diameter. Replacement delays are available in packs of 10. The straight model features a removable handle, which also allows it to be used as a fingertip probe. All models have Microdot connectors.



K-PEN Probes

Freq. (MHz)	Product Codes					
	Straight K-PEN	45° K-PEN	Right Angle K-PEN	.065" Tip Delay 10-PK	.090" Tip Delay 10-PK	6' BNC Cable
7.5	389-042-200	389-042-880	389-042-870	387-003-109	387-003-110	C-012
20.0	389-030-290	389-041-270	389-040-660			

ZIP Probes for Testing Composite and Other Attenuative Plastics

Zero Interface (ZIP) Probes are highly damped, low frequency delay line transducers designed for composite inspection. ZIP delay lines are acoustically matched to most composite and other plastic materials. This eliminates or minimizes the delay line interface echo, significantly improving near surface resolution. The low frequency characteristics of ZIPs make them excellent for penetrating thick or highly attenuative cross-sections. ZIPs can also be used on many smooth surfaced materials without couplant.



Zero Interface Probes (ZIP)

Freq. (MHz)	Size (in.)	Product Codes	Product Codes	
			Cables	Delay Line
0.45	1.00	560-130	6' BNC C-016	D-071
1.5	.500	560-131	6' BNC C-012	D-072
2.25	.375	560-132		D-073

Contact Transducers

Single Element Contact Transducers are longitudinal wave transducers designed for general purpose manual ultrasonic inspection where test materials are relatively flat and smooth. Contact transducers provide high sensitivity for better penetration and are ruggedly constructed for extended service life under the roughest testing conditions.

PFCR and PFCS Style Contacts

The Protective Face Combination transducers are designed to allow one basic transducer to be used with three different types of protective face: membrane, wear cap, or delay line. All models have BNC connectors, PFCR are right angle mount and PFCS are top-mount.

Style PM Kit includes a knurled ring, gland nut, wrench, 12 membranes, and a 2 oz. bottle of couplant (transducer not included).

Style PWC Kit includes a knurled ring, three wear caps, and a 2 oz. bottle of couplant (transducer not included). This option may not be usable if near surface resolution is critical.

Style PHTD Kit includes a knurled ring, either 1" or 1.5" long high temperature delay line, and a 2 oz. bottle of couplant (transducer not included).

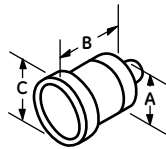

Element Ø	A	B	C
.500	.75	1.20	.94
.750	1.00	1.20	1.19
1.000	1.25	1.20	1.44

Protective Face Combination Transducers—PFCR/PFCS Style

Freq. (MHz)	Size (in.)	Product Codes		Freq. (MHz)	Size (in.)	Product Codes	
		Gamma Series PFCR Style	Gamma Series PFCS Style			Gamma Series PFCR Style	Gamma Series PFCS Style
1.0	.500	241-240	241-260	3.50	.500	243-240	243-260
	.750	251-240	251-260		.750	253-240	253-260
	1.00	261-240	261-260		1.00	263-240	263-260
2.25	.500	242-240	242-260	5.0	.500	244-240	244-260
	.750	252-240	252-260		.750	254-240	254-260
	1.00	262-240	262-260		1.00	264-240	264-260

Accessories—PFCR/PFCS

	Product Codes	Transducer Element Ø		
		.500"	.750"	1.00"
		Spare Membranes Pkg. of 12 pcs.	PM-020	PM-021
Spare Wear caps Pkg. of 12 pcs.	PC-123	PC-122	PC-121	
Hi-Temp. Delay Line* 1.0" Long	PD-027	PD-031	PD-035	
Hi-Temp. Delay Line* 1.5" Long	PD-029	PD-033	PD-037	
6" BNC cable		C-016		
Membrane, Wear cap & Delay line Couplant		XD-740		

Protective Face Option Kits—PFCR/PFCS

Kit Style	Product Codes		
	Transducer Element Ø		
	.500"	.750"	1.00"
PM	PK-120	PK-140	PK-160
PWC	PK-220	PK-240	PK-260
PHTD (1" Delay)*	PK-320	PK-340	PK-360
PHTD (1.5" Delay)*	PK-420	PK-440	PK-460

* High Temp (PHTD) delay line: maximum temperature 400°F, maximum contact time 10 seconds; cool to ambient before reuse.

Contact Transducers

Single Element Contact Transducers are longitudinal wave transducers designed for general purpose manual ultrasonic inspection where test materials are relatively flat and smooth. Contact transducers provide high sensitivity for better penetration and are ruggedly constructed for extended service life under the roughest testing conditions.

PMCR and PMCS Style Contacts

Protective Membrane Contact Transducers are excellent for coupling to rough or uneven surfaces. The membrane will conform to surface irregularities providing better coupling to the test material. PMCR and PMCS Style contacts are designed for quick, easy membrane replacement and have color-coded grips identifying transducer frequency. The PMCR Style has right angle BNC connectors while the PMCS Style has straight top-mount BNC connectors.

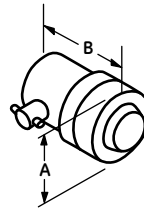

Element Ø	A	B
.500	1.13	1.75
.750	1.41	1.75
1.000	1.63	1.75

Protective Membrane Transducers—PMCR/PMCS Style

Freq. (MHz)	Size (in.)	Product Codes			Freq. (MHz)	Size (in.)	Product Codes		
		Gamma Series	Membranes 1 dozen	Accessories			Gamma Series	Membranes 1 dozen	Accessories
1.0	.500	241-241-PMCR 241-261-PMCS	PM-020	Cables 6' BNC C-016	3.5	.500	243-241-PMCR 243-261-PMCS	PM-020	Cables 6' BNC C-016
	.750	251-241-PMCR 251-261-PMCS	PM-021			.750	253-241-PMCR 253-261-PMCS	PM-021	
	1.00	261-241-PMCR 261-261-PMCS	PM-022			1.00	263-241-PMCR 263-261-PMCS	PM-022	
2.25	0.500	242-241-PMCR 242-261-PMCS	PM-020	6' LEMO C-018	5.00	.500	244-241-PMCR 244-261-PMCS	PM-020	6' LEMO C-018
		252-241-PMCR 252-261-PMCS	PM-021			.750	254-241-PMCR 254-261-PMCS	PM-021	
	0.750	262-241-PMCR 262-261-PMCS	PM-022	Membrane Couplant XD-740		1.00	264-241-PMCR 264-261-PMCS	PM-022	Membrane Couplant XD-740
		1.00	262-241-PMCR 262-261-PMCS			PM-022	1.00	264-241-PMCR 264-261-PMCS	

Contact Transducers

Single Element Contact Transducers are longitudinal wave transducers designed for general purpose manual ultrasonic inspection where test materials are relatively flat and smooth. Contact transducers provide high sensitivity for better penetration and are ruggedly constructed for extended service life under the roughest testing conditions.

PWCCR and PWCCS Style Contacts

Protective Wear Cap Contact Transducers have expendable wear caps which are easily replaced when worn. This means unlimited economy when the job calls for "scrubbing" which would normally destroy a standard contact probe. The PWCCR Style has right angle mounted BNC connectors while the PWCCS Style has straight top-mount BNC connectors. High temperature delay lines are also available for applications to 400°F.

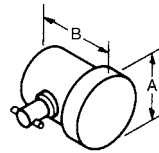

Element Ø	A	B
.500	1.0	1.12
.750	1.25	1.12
1.000	1.50	1.12

Protective Wear Cap/Delay Line Transducers—PWCCR/PWCCS

Freq. (MHz)	Size (in.)	Product Codes				Freq. (MHz)	Size (in.)	Product Codes			
		Gamma Series	Wear Cap 10 pc. Kit	HT Delay Line Kit*	Accessories			Gamma Series	Wear Cap 10 pc. Kit	HT Delay Line Kit*	Accessories
1.0	.500	241-250-PWCCR 241-270-PWCCS	PC-221	PK-050-1" PK-060-1.5"	Cables 6' BNC C-016 6' LEMO C-018	3.5	.500	243-250-PWCCR 243-270-PWCCS	PC-221	PK-050-1" PK-060-1.5"	Cables 6' BNC C-016 6' LEMO C-018
	.750	251-250-PWCCR 251-270-PWCCS	PC-241	PK-070-1" PK-080-1.5"			.750	253-250-PWCCR 253-270-PWCCS	PC-241	PK-070-1" PK-080-1.5"	
	1.00	261-250-PWCCR 261-270-PWCCS	PC-261	PK-090-1" PK-100-1.5"			1.00	263-250-PWCCR 263-270-PWCCS	PC-261	PK-090-1" PK-100-1.5"	
2.25	.500	242-250-PWCCR 242-270-PWCCS	PC-221	PK-050-1" PK-060-1.5"	Wear Cap Couplant XD-740	5.0	.500	244-250-PWCCR 244-270-PWCCS	PC-221	PK-050-1" PK-060-1.5"	Wear Cap Couplant XD-740
	.750	252-250-PWCCR 252-270-PWCCS	PC-241	PK-070-1" PK-080-1.5"			.750	254-250-PWCCR 254-270-PWCCS	PC-241	PK-070-1" PK-080-1.5"	
	1.00	262-250-PWCCR 262-270-PWCCS	PC-261	PK-090-1" PK-100-1.5"			1.00	264-250-PWCCR 264-270-PWCCS	PC-261	PK-090-1" PK-100-1.5"	

* High Temp (HT) Delay Line: maximum temperature 400°F, maximum contact time 10 seconds; cool to ambient before reuse.

Angle Beam Transducers

Angle Beam Transducers are single or dual element transducers designed for weld inspection or flaw detection where flaws have an angular orientation with respect to the material surface. Weld inspections are performed using shear waves refracted from a longitudinal wave by means of a lucite wedge. Lucite wedges are designed to produce shear waves of a particular angle in a specified material with minimal wedge noise.



SWS and AWS Style Angle Beam, Gamma Series

SWS and AWS Style Angle Beam Transducers are designed to fit on removable wedges. Refracted shear wave angles may be specified as required. The AWS series are designed to meet or exceed all of the requirements outlined in AWS Structural Welding Code D1.1. All SWS and AWS transducers utilize captive screws for fastening the probe to the wedge and have top-mount BNC connectors. High temperature wedges are for temperatures up to 400° F.

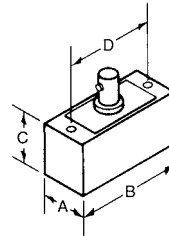

Element Size	A	B	C	D
.50 dia.	.72	1.0	.75	.81
.50 x 1.0	.725	1.51	.75	1.31
.75 x 1.0	1.00	1.5	.75	1.31
1.0	1.22	1.65	.75	1.38
.625 x .625	.725	1.25	.75	1.00
.625 x .750	.725	1.25	.75	1.00
.750 x .750	.85	1.25	.75	1.00

Standard Angle Beam—SWS and AWS Styles, Gamma Series

Freq. (MHz)	Size (in.)	Product Codes				Freq. (MHz)	Size (in.)	Product Codes			
		Gamma Series	Standard Wedge	Hi-Temp Wedge*	Accessories			Gamma Series	Standard Wedge	Hi-Temp Wedge*	Accessories
0.50	1.0 Dia	260-600	W-021 45° W-022 60° W-023 70° W-025 90°	W-081 45° W-082 60° W-083 70°	Cables 6' BNC C-016 6' LEMO C-018 Wedge Couplant XD-740	2.25 AWS Series	.63 x .63	292-603	W-104 45° W-105 60° W-106 70°		
	.5 Dia	241-600	W-009 45° W-010 60° W-011 70° W-013 90°	W-076 45° W-077 60° W-078 70°			.63 x .75	292-601	W-104 45° W-105 60° W-106 70°		
		.5 x 1	291-600	W-015 45° W-016 60° W-017 70° W-019 90°			W-070 45° W-086 60° W-071 70°	.75 x .75	292-604	W-104 45° W-105 60° W-106 70°	
	1.0	.75 x 1	291-605	W-051 45° W-052 60° W-053 70° W-054 90°				.5 Dia	243-600	W-009 45° W-010 60° W-011 70° W-013 90°	W-076 45° W-077 60° W-078 70°
261-600			W-021 45° W-022 60° W-023 70° W-025 90°	W-081 45° W-082 60° W-083 70°	.5 x 1	293-600	W-015 45° W-016 60° W-017 70° W-019 90°	W-070 45° W-086 60° W-071 70°	Cables 6' BNC C-016		
.5 Dia		242-600	W-009 45° W-010 60° W-011 70° W-013 90°	W-076 45° W-077 60° W-078 70°	1.0 Dia	263-600	W-021 45° W-022 60° W-023 70° W-025 90°	W-081 45° W-082 60° W-083 70°	6' LEMO C-018		
		292-600	W-015 45° W-016 60° W-017 70° W-019 90°	W-070 45° W-086 60° W-071 70°	.5 Dia	244-600	W-009 45° W-010 60° W-011 70° W-013 90°	W-076 45° W-077 60° W-078 70°	Wedge Couplant XD-740		
2.25	.75 x 1	292-605	W-051 45° W-052 60° W-053 70° W-054 90°		5.0	.5 x 1	294-600	W-015 45° W-016 60° W-017 70° W-019 90°	W-070 45° W-086 60° W-071 70°		
		262-600	W-021 45° W-022 60° W-023 70° W-025 90°	W-081 45° W-082 60° W-083 70°			.75 x 1	294-605	W-051 45° W-052 60° W-053 70° W-054 90°		
	1.0 Dia	264-600	W-021 45° W-022 60° W-023 70° W-025 90°	W-081 45° W-082 60° W-083 70°		1.0 Dia	264-600	W-021 45° W-022 60° W-023 70° W-025 90°	W-081 45° W-082 60° W-083 70°		

* Duty Cycle: at 400°F, maximum contact time is 10 seconds; cool to ambient before reuse. Note: Standard wedge angles are specified for carbon steel.

Angle Beam Transducers

Angle Beam Transducers are single or dual element transducers designed for weld inspection or flaw detection where flaws have an angular orientation with respect to the material surface. Weld inspections are performed using shear waves refracted from a longitudinal wave by means of a lucite wedge. Lucite wedges are designed to produce shear waves of a particular angle in a specified material with minimal wedge noise.

SWS and AWS Style Angle Beam, Benchmark Series

Benchmark series SWS and AWS Style Angle Beam Transducers feature proprietary BENCHMARK COMPOSITE® active elements. They are available in the same range of sizes and fit the same removable wedges as the Gamma series. Benchmark series offer a superior combination of sensitivity, resolution, and penetration for punching through highly attenuative materials. They are especially beneficial when signal to noise ratio is a problem, for example coarse grain materials and fiber reinforced composites. The AWS models meet all requirements of Structural Welding Code D1.1.



Standard Angle Beam—SWS and AWS Styles, Benchmark Series

Freq. (MHz)	Size (in.)	Product Codes			Freq. (MHz)	Size (in.)	Product Codes			
		Benchmark Series	Standard Wedge	Accessories			Benchmark Series	Standard Wedge	Accessories	
1.0	.5 Dia	841-600	W-009 45° W-010 60° W-011 70° W-013 90°	Cables 6'BNC C-016 6' LEMO C-018 Wedge Couplant XD-740	3.5	.5 Dia	843-600	W-009 45° W-010 60° W-011 70° W-013 90°	Cables 6'BNC C-016 6' LEMO C-018 Wedge Couplant XD-740	
	.5 x 1	891-600	W-015 45° W-016 60° W-017 70° W-019 90°			.5 x 1	893-600	W-015 45° W-016 60° W-017 70° W-019 90°		
	.75 x 1	891-605	W-051 45° W-052 60° W-053 70° W-054 90°			.75 x 1	893-605	W-051 45° W-052 60° W-053 70° W-054 90°		
	1.0 Dia	861-600	W-021 45° W-022 60° W-023 70° W-025 90°			1.0 Dia	863-600	W-021 45° W-022 60° W-023 70° W-025 90°		
2.25	.5 Dia	842-600	W-009 45° W-010 60° W-011 70° W-013 90°		5.0	.5 Dia	844-600	W-009 45° W-010 60° W-011 70° W-013 90°		
	.5 x 1	892-600	W-015 45° W-016 60° W-017 70° W-019 90°			.5 x 1	894-600	W-015 45° W-016 60° W-017 70° W-019 90°		
	.75 x 1	892-605	W-051 45° W-052 60° W-053 70° W-054 90°			.75 x 1	894-605	W-051 45° W-052 60° W-053 70° W-054 90°		
	1.0 Dia	862-600	W-021 45° W-022 60° W-023 70° W-025 90°			1.0 Dia	864-600	W-021 45° W-022 60° W-023 70° W-025 90°		
2.25 AWS Series	.63 x .63	892-603	W-104 45° W-105 60° W-106 70°							
	.63 x .75	892-601	W-104 45° W-105 60° W-106 70°							
	.75 x .75	892-604	W-104 45° W-105 60° W-106 70°							

Note: Standard wedge angles are specified for carbon steel.

Angle Beam Transducers

Angle Beam Transducers are single or dual element transducers designed for weld inspection or flaw detection where flaws have an angular orientation with respect to the material surface. Weld inspections are performed using shear waves refracted from a longitudinal wave by means of a Lucite wedge. Lucite wedges are designed to produce shear waves of a particular angle in a specified material with minimal wedge noise.



MSW-QC Style Angle Beam, Gamma Series

MSW-QC Style are miniature angle beam transducers that screw directly into our "Quick Change" Lucite wedges. All MSW-QC transducers have top-mount Microdot connectors. Gamma series utilize conventional monolithic ceramic elements and are recommended for regular inspection of non-attenuative materials. 10.0 MHz MSW-QC transducers are available only in Gamma series.

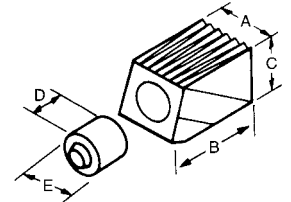

Wedge Angle	Replaceable Wedge .25"					Wedge Angle	Replaceable Wedge .375"					Wedge Angle	Replaceable Wedge .50"				
	A	B	C	D	E		A	B	C	D	E		A	B	C	D	E
45°	.45	.75	.37	.41	.47	45°	.55	.89	.47	.56	.50	45°	.70	1.05	.55	.70	.62
60°	.45	.84	.44	.41	.47	60°	.55	1.04	.55	.56	.50	60°	.70	1.24	.64	.70	.62
70°	.45	1.00	.50	.41	.47	70°	.55	1.19	.58	.56	.50	70°	.70	1.41	.68	.70	.62
90°	.45	.95	.50	.41	.47	90°	.55	1.15	.61	.56	.50	90°	.70	1.39	.73	.70	.62

Miniature Angle Beam Transducers—MSW-QC Style

Freq. (MHz)	Size (in.)	Product Codes			Freq. (MHz)	Size (in.)	Product Codes		
		Gamma Series	Standard Wedge	Accessories			Gamma Series	Standard Wedge	Accessories
1.0	.500	241-590	W-210 30° W-211 45° W-212 60° W-213 70° W-214 90°	Cables 6' BNC C-012 6' LEMO C-022 Wedge Couplant XD-740	3.5 cont.	.500	243-590	W-210 30° W-211 45° W-212 60° W-213 70° W-214 90°	
	1.5	.375	231-590			W-220 30° W-221 45° W-222 60° W-223 70° W-224 90°	.250	224-590	W-200 30° W-201 45° W-202 60° W-203 70° W-204 90°
1.5		.500	241-595		W-210 30° W-211 45° W-212 60° W-213 70° W-214 90°	5.0	.375	234-590	W-220 30° W-221 45° W-222 60° W-223 70° W-224 90°
	2.25	.250	222-590		W-200 30° W-201 45° W-202 60° W-203 70° W-204 90°		.500	244-590	W-210 30° W-211 45° W-212 60° W-213 70° W-214 90°
2.25		.375	232-590		W-220 30° W-221 45° W-222 60° W-223 70° W-224 90°	10	.250	226-590	W-200 30° W-201 45° W-202 60° W-203 70° W-204 90°
	2.25	.500	242-590		W-210 30° W-211 45° W-212 60° W-213 70° W-214 90°		.375	236-590	W-220 30° W-221 45° W-222 60° W-223 70° W-224 90°
3.5		.250	223-590		W-200 30° W-201 45° W-202 60° W-203 70° W-204 90°	10	.500	246-590	W-210 30° W-211 45° W-212 60° W-213 70° W-214 90°
	3.5	.375	233-590		W-220 30° W-221 45° W-222 60° W-223 70° W-224 90°				

Note: Standard wedge angles are specified for carbon steel.

Angle Beam Transducers

Angle Beam Transducers are single or dual element transducers designed for weld inspection or flaw detection where flaws have an angular orientation with respect to the material surface. Weld inspections are performed using shear waves refracted from a longitudinal wave by means of a lucite wedge. Lucite wedges are designed to produce shear waves of a particular angle in a specified material with minimal wedge noise.

MSW-QC Style Angle Beam, Benchmark and Alpha Series

Benchmark and Alpha series MSW-QC Miniature Angle Beam Transducers are available in the same range of sizes and fit the same standard "Quick Change" wedges as the Gamma series. Their one-piece stainless steel case insures long service life. All MSW-QC probes are color coded by frequency and have top mounted Microdot connectors.

Benchmark series probes feature proprietary BENCHMARK COMPOSITE® active elements. They offer a superior combination of sensitivity, resolution, and penetration for punching through highly attenuative materials. They are especially beneficial when signal to noise ratio is a problem, for example coarse grain materials and fiber reinforced composites. Alpha series MSW-QC probes are made with highly damped monolithic ceramic elements and are recommended when very short pulse lengths are required for axial resolution.



Miniature Angle Beam Transducers—MSW-QC Style

Freq. (MHz)	Size (in.)	Product Codes			Accessories	Freq. (MHz)	Size (in.)	Product Codes			Accessories
		Benchmark Series	Alpha Series	Standard Wedge				Benchmark Series	Alpha Series	Standard Wedge	
1.0	.500	241-591	141-591	W-210 30° W-211 45° W-212 60° W-213 70° W-214 90°	Cables 6' BNC C-016 6' LEMO C-022 Wedge Couplant XD-740	3.5 cont.	.500	243-591	143-591	W-210 30° W-211 45° W-212 60° W-213 70° W-214 90°	Cables 6' BNC C-012 6' LEMO C-022 Wedge Couplant XD-740
	.375	231-596	131-596	W-220 30° W-221 45° W-222 60° W-223 70° W-224 90°				.250	224-591	124-591	
1.5	.500	241-596	141-596	W-210 30° W-211 45° W-212 60° W-213 70° W-214 90°		5.0	.375	234-591	134-591	W-220 30° W-221 45° W-222 60° W-223 70° W-224 90°	
	.250	222-591	122-591	W-200 30° W-201 45° W-202 60° W-203 70° W-204 90°				.500	244-591	144-591	
2.25	.375	232-591	132-591	W-220 30° W-221 45° W-222 60° W-223 70° W-224 90°		7.5	.375	225-591	125-591	W-200 30° W-201 45° W-202 60° W-203 70° W-204 90°	
	.500	242-591	142-591	W-210 30° W-211 45° W-212 60° W-213 70° W-214 90°				.500	245-591	145-591	
3.5	.250	223-591	123-591	W-200 30° W-201 45° W-202 60° W-203 70° W-204 90°		7.5	.500	245-591	145-591	W-210 30° W-211 45° W-212 60° W-213 70° W-214 90°	
	.375	233-591	133-591	W-220 30° W-221 45° W-222 60° W-223 70° W-224 90°							

Note: Standard wedge angles are specified for carbon steel.

Angle Beam Transducers

Angle Beam Transducers are single or dual element transducers designed for weld inspection or flaw detection where flaws have an angular orientation with respect to the material surface. Weld inspections are performed using shear waves refracted from a longitudinal wave by means of a lucite wedge. Lucite wedges are designed to produce shear waves of a particular angle in a specified material with minimal wedge noise.

MSWS Style Angle Beam

MSWS Angle Beam Transducers are designed to fit removable lucite wedges. Refracted shear wave angles may be specified as required. All MSWS transducers have captive screws for fastening the probe to the wedge and are fitted with Microdot connectors. High temperature wedges are for use at temperatures up to 400°F.



Wedge Angle	Replaceable Wedge .25"						Wedge Angle	Replaceable Wedge .50"					
	A	B	C	D	E	F		A	B	C	D	E	F
45°	.47	.60	.30	.31	.48	.34	45°	.73	.96	.42	.56	.73	.50
60°	.47	.65	.35	.31	.48	.34	60°	.73	1.08	.50	.56	.73	.50
70°	.47	.70	.38	.31	.48	.34	70°	.73	1.16	.54	.56	.73	.50
90°	.47	.90	.38	.31	.48	.34	90°	.73	1.56	.58	.56	.73	.50

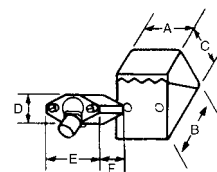

Miniature Angle Beam Transducers—MSWS Style

Freq. (MHz)	Size (in.)	Product Codes			Freq. (MHz)	Size (in.)	Product Codes		
		Gamma Series	Standard Wedge	Accessories			Gamma Series	Standard Wedge	Accessories
1.0	.500	241-580	W-040 45° W-042 60° W-044 70° W-046 80° W-048 90°		5.0	.250	224-580	W-028 45° W-030 60° W-032 70° W-034 80° W-036 90°	
	.250		222-580					W-028 45° W-042 60° W-032 70° W-034 80° W-036 90°	
2.25	.500	242-580	W-040 45° W-042 60° W-044 70° W-046 80° W-048 90°	6' LEMO C-022	10.0	.250	226-580	W-028 45° W-030 60° W-032 70° W-034 80° W-036 90°	Wedge Couplant XD-740
	.250		223-580					W-028 45° W-030 60° W-032 70° W-034 80° W-036 90°	
3.5	.500	243-580	W-040 45° W-042 60° W-044 70° W-046 80° W-048 90°					W-040 45° W-042 60° W-044 70° W-046 80° W-048 90°	

Note: Standard wedge angles are specified for carbon steel.

Angle Beam Transducers

Angle Beam Transducers are single or dual element transducers designed for weld inspection or flaw detection where flaws have an angular orientation with respect to the material surface. Weld inspections are performed using shear waves refracted from a longitudinal wave by means of a lucite wedge. Lucite wedges are designed to produce shear waves of a particular angle in a specified material with minimal wedge noise.



ABFP Style Angle Beam

ABFP Style, fingertip, fixed angle, shear wave transducers are available in standard angles for inspecting steel and aluminum. Custom angles for other materials may be special ordered. Their small size makes them ideal for weld inspection in restricted access areas. All ABFP Transducers are equipped with right angle Microdot connectors. Top mounted connectors may be special ordered.

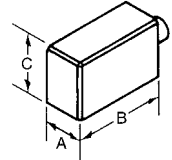

Fingertip Potted Angle Beam Transducers—ABFP Style

Freq. (MHz)	Size (in.)	Product Codes				Accessories
		45°	60°	70°	90°	
2.25	.187 x .187	292-640	292-641	292-642	292-643	Cables 6' BNC C-012
	.250 x .250	292-620	292-621	292-622	292-623	
5.0	.187 x .187	294-640	294-641	294-642	294-643	6' LEMO C-022
	.250 x .250	294-620	294-621	294-622	294-623	
10.0	.187 x .187	296-640	296-641	296-642	296-643	6' LEMO C-022
	.250 x .250	296-620	296-621	296-622	296-623	

Element Dimensions	A	B	C
.187 x .187	.32	.70	.57
.25 x .25	.50	1.0	.55

Note: Part numbers above are for carbon steel. For aluminum, specify frequency, size, and refracted angle in aluminum.

SMSWS Style Angle Beam

SMSWS Angle Beam Transducers are subminiature transducers designed to fit removable lucite wedges. Refracted shear wave angles may be specified as required. All SMSWS transducers have standard screws for fastening the probe to the wedge and have top-mount miniature Microdot connectors.



Subminiature Angle Beam—SMSWS Style

Freq. (MHz)	Size (in.)	Product Codes		Accessories
		Gamma Series	Standard Wedge	
2.25	.125	212-585	W-120 45°	Cables 6' BNC C-047
			W-121 60°	
			W-122 70°	
			W-123 90°	
5.0	.125	214-585	W-120 45°	Wedge Couplant XD-740
			W-121 60°	
			W-122 70°	
			W-123 90°	
10.0	.125	216-585	W-120 45°	
			W-121 60°	
			W-122 70°	
			W-123 90°	

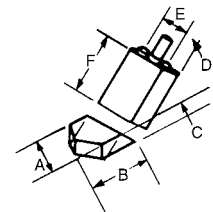

Angle	Wedge Dimensions					
	A	B	C	D	E	F
45°	.31	.25	.21	.19	.23	.28
60°	.31	.42	.21	.19	.23	.28
70°	.31	.42	.21	.19	.23	.28
90°	.31	.72	.34	.19	.23	.28

Note: Standard wedge angles are specified for carbon steel.

Dual Element Transducers

Dual Element Contact Transducers are longitudinal wave transducers with a split element; one half functions as a transmitter while the other functions as a receiver. Each half-element is angled slightly toward the other forming the "roof" angle. This "roof" angle effectively focuses the sound beam. These transducers are excellent for thin range flaw detection and thickness gauging. Because they have a discrete transmitter and receiver, better signal to noise ratios are achieved compared to single element transducers.



ADP, RC, and FDU Style Dual Element

Dual Element Transducers are for general flaw detection and thickness gauging on materials with irregular or pitted surfaces. The ADP and RC models are color coded for quick frequency identification. The low profile ADP model has a potted BNC cable. The RC Dual models have a 4-pin LEMO connector which allows for quick and easy cable replacement. All FDU models have mini Microdot threaded connectors. All models may be contoured to fit ID and OD curvatures.

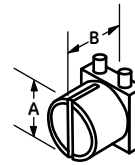

FDU

Element Ø	A	B
.250	.38	.50
.375	.50	.50

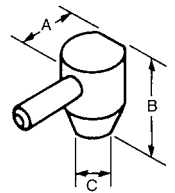

ADP/RC

Element Ø	A	B	C
.250	.50	.64	.36
.375	.63	.64	.47
.500	.75	.68	.60

Fingertip Dual Element Transducers—ADP/RC/FDU Styles

Freq. (MHz)	Size (in.)	Product Codes			Freq. (MHz)	Size (in.)	Product Codes		
		ADP Dual	RC Dual*	FDU Dual			ADP Dual	RC Dual*	FDU Dual†
2.25	.250	222-700	222-681	222-680	5.0	.250	224-700	224-681	224-680
	.375	232-700	232-681	232-680		.375	234-700	234-681	234-680
	.500	242-700	242-681			.500	244-700	244-681	
3.5	.250	223-700	223-681	223-680	7.5	.375	135-700		
	.375	233-700	233-681	233-680					
	.500	243-700	243-681						

* Standard BNC Cable (C-088) or Heavy Duty BNC Cable (C-089) sold separately

† Standard BNC Cable (C-014) sold separately

HT400A and KBA560V Style High Temperature Dual Element Transducers

HT400A and KBA560V models are available with replaceable BNC cables and can be used for both flaw detection and thickness gauging applications. Model HT400A can be used intermittently on materials up to 1000° F. Model KBA560V can be used intermittently on materials up to 750° F.



High Temperature Transducers*

Freq. (MHz)	Size (in.)	Product Codes		
		Model	Gamma Series	Accessories
5.0	.250	HT400A	224-760	Cables 6' BNC Standard: C-102 Armored: C-101
	.375	KBA560V	544-230	Cable 6' BNC C-067

*Duty Cycle: KBA560V—750°F, maximum contact time is 10 seconds; HT400A—1000°F, maximum contact time is 5 seconds; cool to ambient before reuse.

Dual Element Transducers

Dual Element Contact Transducers are longitudinal wave transducers with a split element; one half functions as a transmitter while the other functions as a receiver. Each half-element is angled slightly toward the other forming the “roof” angle. This “roof” angle effectively focuses the sound beam. These transducers are excellent for thin range flaw detection and thickness gauging. Because they have a discrete transmitter and receiver, better signal to noise ratios are achieved compared to single element transducers.



DU Style Dual Element

DU Dual Element Transducers with replaceable delays are excellent general-purpose probes for applications with flat or curved surfaces. High temperature delays are also available for inspections at temperatures up to 400°F. All DU transducers have standard Microdot connectors for easy replacement.

Element Size	A	B	C
.500 x .500	.75	.85	.78
.500 x 1.00	1.38	.92	.78

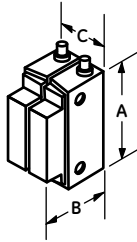

Standard Dual Element Transducers–DU Style

Freq. (MHz)	Size (in.)	Product Codes			Accessories
		Gamma Series	Delay Set	HT Delay Set*	
1.00	.5 x .5	291-750	DS-620	DS-720	Cables 6' BNC C-024
	.5 x 1	291-740	DS-640	DS-740	
2.25	.5 x .5	292-750	DS-620	DS-720	Coulplant XD 740
	.5 x 1	292-740	DS-640	DS-740	
5.0	.5 x .5	294-750	DS-620	DS-720	Coulplant XD 740
	.5 x 1	294-740	DS-660	DS-760	

*Duty Cycle: at 750°F, maximum contact time is 10 seconds; cool to ambient before reuse.

DU-F Style Dual Element, Benchmark Series

Benchmark series DU-F Style Dual Element Transducers feature proprietary BENCHMARK COMPOSITE® active elements. Benchmark series offer a superior combination of sensitivity, resolution, and penetration for punching through highly attenuative materials. They are especially beneficial when signal to noise ratio is a problem, for example coarse grain materials and fiber reinforced composites. Close tolerance, integral delays assure consistent performance.



Standard Dual Element Transducers–DU-F Style

Freq. (MHz)	Size (in.)	Product Codes	
		Benchmark Series	Accessories
2.25	.5 x .5	292-751	Cable 6' BNC C-024
	.5 x 1	292-741	
5.0	.5 x .5	294-751	Cable 6' BNC C-024
	.5 x 1	294-741	

FAST™ Probes for Rapid Manual Weld Inspection

Benchmark series FAST™ Probes are dual, high angle, longitudinal wave probes with proprietary BENCHMARK COMPOSITE® elements. They are primarily for inspection using the FAST™ method developed by SPIN (LLC). FAST™ high speed, manual weld scanning can reduce inspection costs for fabrication shops, field welding organizations, or any industry that performs inservice NDE of components. For a detailed Product Bulletin, contact our sales department.



FAST™ Probes

Model	Freq. (MHz)	Useful Depth	Product Codes
FAST1	5.0	0" to 0.6"	389-016-880
FAST2	5.0	0" to 1.5"	389-016-900
FAST3	5.0	0.5" to 4"	389-016-780

Immersion Transducers

Single Element Immersion Transducers are longitudinal wave transducers typically used in manual, semi-automatic, and automatic scanning systems. Scanning parts with irregular or complex geometries is possible because of the conforming "water path" layer between the probe and the inspected material. Superior near-surface resolution can be achieved when compared to contact transducers. Angle beam inspection is possible by simply angling the probe or search tube in relation to the part surface. Spherical (point) or cylindrical (line) focusing can also be accomplished using acoustically matched lenses. Focal length must be specified.

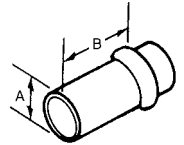

ISS and IS Style Element

ISS and IS Immersion Transducers are for general ultrasonic immersion inspections requiring element diameters between .25" and 1.0". Available in Alpha, Gamma, and BENCHMARK COMPOSITE® series, they can be focused for critical applications to improve near-surface resolution or sensitivity to small discontinuities. All ISS and IS Transducers have waterproof UHF connectors. BNC connectors may be special ordered. Gamma Series are recommended for applications where high sensitivity and penetration are required. Alpha Series (where available) are designed for optimum damping and resolution. New Benchmark Series (where available), with BENCHMARK COMPOSITE® elements, offer a superior combination of sensitivity, resolution, and penetration for punching through highly attenuative materials.

Element Ø	A	B
.250	.63	1.55
.375	.63	1.55
.500	.63	1.55
.750	1.0	1.77
1.00	1.25	1.82

Immersion Transducers—ISS and IS Styles

Freq. (MHz)	Size (in.)	Product Codes			Freq. (MHz)	Size (in.)	Product Codes				
		*Focus	Alpha Series	Gamma Series			Benchmark Series	*Focus	Alpha Series	Gamma Series	Benchmark Series
1.0	.250	N		221-300	5.0	.250	S C N	124-280 124-290 124-300	224-280 224-290 224-300	824-300	
	.375	N		231-300		.375	S C N	134-280 134-290 134-300	234-280 234-290 234-300	834-280 834-290 834-300	
	.500	S C N		241-280 241-290 241-300		.500	S C N	144-280 144-290 144-300	244-280 244-290 244-300	844-280 844-290 844-300	
	.750	S C N		251-360 251-370 251-380		.750	S C N	154-360 154-370 154-380	254-360 254-370 254-380	854-360 854-370 854-380	
	1.00	S C N		261-360 261-370 261-380		861-360 861-370 861-380	1.00	S C N	164-360 164-370 164-380	264-360 264-370 264-380	864-360 864-370 864-380
2.25	.250	S C N	122-280 122-290 122-300	222-280 222-290 222-300	10.0	.250	S C N	126-280 126-290 126-300	226-280 226-290 226-300	822-300	
	.375	S C N	132-280 132-290 132-300	232-280 232-290 232-300		.375	S C N	136-280 136-290 136-300	236-280 236-290 236-300	832-300	
	.500	S C N	142-280 142-290 142-300	242-280 242-290 242-300		.500	S C N	146-280 146-290 146-300	246-280 246-290 246-300	842-280 842-290 842-300	
	.750	S C N	152-360 152-370 152-380	252-360 252-370 252-380		.750	S C N	156-360 156-370 156-380	256-360 256-370 256-380	852-360 852-370 852-380	
	1.00	S C N	162-360 162-370 162-380	262-360 262-370 262-380		862-360 862-370 862-380	.250	S C N	127-280 127-290 127-300		
3.5	.250	S C N	123-280 123-290 123-300	223-280 223-290 223-300	15.0	.250	1.5"S	127-302 (TTC-100)			
	.375	S C N	133-280 133-290 133-300	233-280 233-290 233-300		.375	S C N	137-280 137-290 137-300			
	.500	S C N	143-280 143-290 143-300	243-280 243-290 243-300		.500	S C N	147-280 147-290 147-300			
	.750	S C N	153-360 153-370 153-380	253-360 253-370 253-380		853-360 853-370 853-380	25.0	.250	S C N	129-280 129-290 129-300	
	1.00	S C N	163-360 163-370 163-380	263-360 263-370 263-380		863-360 863-370 863-380	Note: Waterproof cables are in Accessories Section.				

* Focus: S = Spherical; C = Cylindrical, N = Non-focus. Focal length must be specified. For available focal lengths, see table at the end of the Immersion Transducers section.

Immersion Transducers

Single Element Immersion Transducers are longitudinal wave transducers typically used in manual, semi-automatic, and automatic scanning systems. Scanning parts with irregular or complex geometries is possible because of the conforming "water path" layer between the probe and the inspected material. Superior near-surface resolution can be achieved when compared to contact transducers. Angle beam inspection is possible by simply angling the probe or search tube in relation to the part surface. Spherical (point) or cylindrical (line) focusing can also be accomplished using acoustically matched lenses. Focal length must be specified.

IPS Style Immersion

IPS Immersion Transducers with small diameter cases are designed for immersion applications where transducer size limitations exist. The Alpha series are designed for maximum bandwidth and resolution capabilities. The Gamma series are for increased sensitivity and penetration. All IPS Transducers have Microdot connectors. For best results the connector should be sealed with a nonwater soluble grease.



Immersion Transducers-IPS Style

Freq. (MHz)	Size (in.)	Product Codes			Freq. (MHz)	Size (in.)	Product Codes			
		*Focus	Alpha Series	Gamma Series			Accessories	*Focus	Alpha Series	Gamma Series
1.0	.250	N		221-340	10	.250	S	126-320	226-320	Cable 6' BNC C-012
		C	122-320	222-320			C	126-330	226-330	
		N	122-340	222-340			N	126-340	226-340	
2.25	.250	S	123-320	223-320	15	.125	S	117-320		
		C	123-330	223-330			C	117-330		
		N	123-340	223-340			N	117-340		
3.5	.250	S	123-320	223-320	15	.250	S	127-320		
		C	123-330	223-330			C	127-330		
		N	123-340	223-340			N	127-340		
5.0	.250	S	124-320	224-320	22	.125	S	118-320		
		C	124-330	224-330			C	118-330		
		N	124-340	224-340			N	118-340		
		S	129-320		25	.250	S	129-320		
		C	129-330				C	129-330		
		N	129-340				N	129-340		

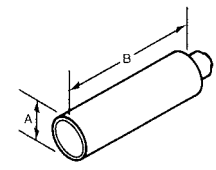

Element Ø	A	B
.125	.38	1.45
.250	.38	1.45

* Focus: S = Spherical; C = Cylindrical; N = Non-focus. Focal length must be specified. For available focal lengths, see table at the end of the Immersion Transducers section.

IR Style Immersion

IR Immersion Transducers are used where .25" to .5" diameter probes are desired, but where space constraints exist that prohibit the use of standard ISS Style transducers. IR Style transducers have a right angle mounted UHF connector and will fit into a 1.5 cubic inch area. The IR is available in both the Alpha and Gamma series and can be focused for critical applications to improve near-surface resolution or sensitivity to small discontinuities.

Immersion Transducers-IR Style

Freq. (MHz)	Size (in.)	Product Codes		Freq. (MHz)	Size (in.)	Product Codes			
		*Focus	Alpha Series			Gamma Series	*Focus	Alpha Series	Gamma Series
1.0	.250	N		221-420	3.5	.250	N	123-420	223-420
		C					C	123-410	223-410
		S					S	123-400	223-400
	.375	N		231-420		.375	N	133-420	233-420
		C					C	133-410	233-410
		S					S	133-400	233-400
2.25	.500	N		241-420	5.0	.500	N	143-420	243-420
		C		241-410			C	143-410	243-410
		S		241-400			S	143-400	243-400
	.250	N	122-420	222-420		.250	N	124-420	224-420
		C	122-410	222-410			C	124-410	224-410
		S	122-400	222-400			S	124-400	224-400
.375	N	132-420	232-420	.375	N	134-420	234-420		
	C	132-410	232-410		C	134-410	234-410		
	S	132-400	232-400		S	134-400	234-400		
.500	N	142-420	242-420	.500	N	144-420	244-420		
	C	142-410	242-410		C	144-410	244-410		
	S	142-400	242-400		S	144-400	244-400		

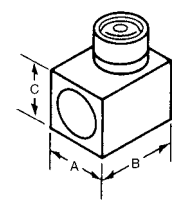

Element Ø	A	B	C
.250, .375, .500	.75	.94	.75

* Focus: S = Spherical; C = Cylindrical; N = Non-focus. Focal length must be specified. For available focal lengths, see table at the end of the Immersion Transducers section. Note: Waterproof cables are available in Accessories Section.

Immersion Transducers

Single Element Immersion Transducers are longitudinal wave transducers typically used in manual, semi-automatic, and automatic scanning systems. Scanning parts with irregular or complex geometries is possible because of the conforming "water path" layer between the probe and the inspected material. Superior near-surface resolution can be achieved when compared to contact transducers. Angle beam inspection is possible by simply angling the probe or search tube in relation to the part surface. Spherical (point) or cylindrical (line) focusing can also be accomplished using acoustically matched lenses. Focal length must be specified.

Velocity System Immersion Transducers

These transducers are specifically designed for use with through transmission GE Inspection Technologies Velocity Systems. These transducers are available in either the ISS Style or IR Style housing and are provided with standard waterproof UHF connectors.



Velocity System Immersion Transducers ISS/IR Styles

Freq. (MHz)	Product Codes	
	Style ISS	Style IR
5.0	144-301	144-421

Immersion Transducer Focal Lengths

$$N = \frac{(\text{Dia.})^2 \times (\text{Freq.})}{4 \times \text{Velocity}}$$

Dia. = Crystal diameter
 Freq. = Frequency of probe
 Velocity = Velocity of material

Freq. (MHz)		Element Ø					
		1.0	.75	.50	.375	.25	.125
1.00	N	4.3	2.4	1.1			
	Min	2.0	1.5	1.0			
	Max	3.0	2.0	1.0			
2.25	N	9.6	5.4	2.4	1.4	.6	
	Min	2.0	1.5	1.0	.8	.5	
	Max	6.0	4.0	2.0	.8	.5	
3.5	N	15.0	8.4	3.7	2.1	.9	
	Min	2.0	1.5	1.0	.8	.5	
	Max	8.0	6.0	2.5	.5	.5	
5.0	N	21.0	12.0	5.4	3.0	1.3	.3
	Min	2.0	1.5	1.0	.8	.5	.3
	Max	8.0	8.0	4.0	2.0	.8	.3
10.0	N		24.0	10.7	6.0	2.7	.7
	Min		1.5	1.0	.8	.5	.3
	Max		8.0	6.0	4.5	1.5	.3
15.0	N			16.0	9.0	4.0	1.0
	Min			1.0	.8	.5	.3
	Max			6.0	6.0	2.0	.5
25.0	N					6.7	1.7
	Min					.5	.3
	Max					2.0	1.0

This table lists the near field lengths and minimum and maximum practical focal lengths in water expressed in inches. To find the approximate near field length in steel, divide all N values by 4.

N = Near field length.
 Min = Minimum practical focal length.
 Max = Maximum practical focal length.

Single Element Transducers

For use with precision thickness gauges

Precision thickness gauging transducers are single element, delay line and contact transducers designed primarily for use with GE Inspection Technologies precision thickness gauges. They may also be used with most standard flaw detection instruments. A wide variety is available to satisfy virtually any inspection requirement on most metals and nonmetals with relatively smooth, parallel front and back surfaces. Depending on probe selection and material conditions, most precision gauges can measure from 0.005 to 15.00 inches in steel and plastic.



CL3 and CL3 DL Compatible Transducer Specifications

Model	Transducer Type	Contact Ø	Nominal Frequency	Measuring Range (steel unless noted)	Product Code
Alpha 2DFR	Delay, Standard Housing	7.6 mm (0.30")	15 MHz	0.25 mm to 25 mm (0.010" to 1.0")	113-527-660
Alpha 2A, Mini DFR	Delay, Small Housing	4.8 mm (0.19")	20 MHz	0.25 mm to 5 mm (0.010" to 0.200")	113-518-655
CA211A	Contact, Standard	19.1 mm (0.75")	5 MHz	2 mm to 381 mm (0.080" to 15.0")	113-544-000
CA215	Contact, Standard	12.7 mm (0.50")	5 MHz	2 mm to 51 mm (0.080" to 2.0")	113-124-011
Alpha 2F	Contact, Fingertip	9.7 mm (0.38")	10 MHz	2 mm to 254 mm (0.80" to 10.0")	113-526-000
Alpha DFR-P	Plastics, Delay Line	7.6 mm (0.30")	22 MHz	0.13 mm to 3.8 mm (0.005" to .150") Plastics only	113-118-661

For instrument and transducer connection use a 022-505-604 cable (Microdot to right angle Lemo connector), or a 022-504-925 (Microdot to straight Lemo Connector)

CL 300 and CL 304 Compatible Transducer Specifications

Model	Transducer Type	Contact Ø	Nominal Frequency	Measuring Range (steel unless noted)	Product Code
Alpha 2DFR	Delay, Standard Housing	7.6 mm (0.30")	15 MHz	0.25 mm to 25 mm (0.007" to 1.0")	113-527-660
Alpha 2A, Mini DFR	Delay, Small Housing	4.8 mm (0.19")	20 MHz	0.13 mm to 5 mm (0.005" to 0.200")	113-518-655
CA211A	Contact, Standard	19.1 mm (0.75")	5 MHz	1.5 mm to 381 mm (0.060" to 15.0")	113-544-000
Alpha 2F	Contact, Fingertip	9.7 mm (0.38")	10 MHz	1.5 mm to 51 mm (0.060" to 10.0")	113-526-000
KBA125	Plastics, Contact	4.6 mm (0.18")	20 MHz	0.25 mm minimum (0.010" minimum) Plastics only	113-518-006
K-Pen CL304 Only	Pencil Style Transducer	1.7 mm or 2.3 mm (.065" or .090")	20 MHz	Dependent on application and required CL 304 special menus setting	389-030-290

Dual Element D-Meter Probes

Compatible with the D-Meter line of ultrasonic thickness gauges

Standard probes are readily available to satisfy a wide range of remaining wall thickness applications including: high-temperature, through-coating, erosion/corrosion, thin materials, areas of limited access, tough-to-penetrate materials (coarse-grained/nonmetals), external pitting, wear resistance, boiler tubing, small diameter piping and tubing, and general-purpose applications.

DIALOG Intelligent Probes are automatically recognized by the DM4 Family of instruments for quick setup, best performance, and test documentation. The model FH2E-D-REM contains a built-in membrane switch with no additional cable lines to send and store readings in the DM4 DL's onboard data logger at a press of the index finger of the probe hand.



Label	Model	Designation	Probe Cable	Contact Ø	Measuring Range in Steel	Temp Range	Product Code
A	FH2E	Fingertip	Potted	.380"	.030" - 2.0"	< 130° F	113-552-005
B	FH2E-D**	Fingertip	Potted	.380"	.030" - 2.0"	< 130° F	113-552-007
C	FH2E-D-REM**	Remote Send	Potted	.380"	.030" - 2.0"	< 130° F	113-552-009
D	KB550FH*	Fingertip	Potted	.375"	.060" - 2.0"	< 130° F	113-550-001
E	DA312	Thin Materials	KBA532	.300"	.025" - 1.0"	< 130° F	083-056-906
F	KBA525	5mm Footprint	Potted	.200"	.025" - 2.0"	< 130° F	113-516-002
G	DA312B16*	3mm Footprint	Potted	.120"	.025" - 5.0"	< 130° F	083-066-934
H	KBA560	General Purpose	KBA531	.625"	.060" - 8.0"	< 450° F	113-544-210
I	KBA560-D**	General Purpose	KBA531	.625"	.060" - 8.0"	< 250° F	113-544-213
J	DA301	General Purpose	KBA533	.475"	.050" - 8.0"	< 140° F	083-056-904
K	DA303	Penetration	KBA533	.635"	.200" min.	< 140° F	083-506-905
L	DP-104	High Penetration	KBA532	1.25"	.200" min.	< 140° F	113-561-104
M	FH2E-WR	Wear Resistant	Potted	.550"	.030" - 2.0"	< 130° F	113-552-006
N	KBA560-WR	Wear Resistant	KBA531	.700"	.060" - 8.0"	< 450° F	113-544-212
O	FH2E-D-WR**	Wear Resistant	Potted	.550"	.030" - 2.0"	< 130° F	113-552-008
P	HT400* HT400A†	High Temperature	KBA535 KBA536	.500"	.040" - 10.0"	< 1000° F	113-524-760 113-224-760
Q	KB550BTH*	Studded Boiler Tube	C-BTH	.375"	.060" - 2.0"	< 130° F	113-550-003

* 2 - PT Calibration required on DM4E, DM4, DM4 DL

** DIALOG INTELLIGENT Probes when used with DM4E, DM4, DM4 DL and DMS 2

† DMS and DMS 2 ONLY

Specifications are subject to change without notice.

Applications and Special Probes Lab

The GE Inspection Technologies Applications Lab has a long history of providing a broad spectrum of services to our customers. Experienced Application Engineers and Specialists will work closely with the customer to provide technical assistance and custom designed products to solve challenging ultrasonic testing applications.

Applications Support Group

This group specializes in the evaluation of customer supplied samples to provide practical recommendations and solutions for ultrasonic testing problems. Typical applications include thickness and velocity measurements, flaw detection and evaluation and material characterization. This group also provides applications support for small, integrated ultrasonic testing systems. The Applications Lab is fully equipped with a large selection of ultrasonic instrumentation to aid in providing total testing solutions.

Special Probes Group

The Special Probes Group designs and manufactures custom transducers for specific ultrasonic testing applications. This may include the modification of transducer case design, element size and shape or the connector type and location. The customer may require transducers with custom electrical and acoustic performance including non-standard frequencies, resolution, sensitivity, bandwidth or focusing. Special test fixtures, custom wedges, delay lines and cables are also designed and built to meet customer specifications.

Examples of Special Probes Types

- I.D. and O.D. Bore Probes.
- Special Paintbrush Probes.
- Coarse Grain Inspection Probes.
- Special Focused Probes.
- High Temperature Probes.
- Multiple Transducer Probes.
- Advanced Flaw Sizing Probes.
- Radiation Resistant Probes.
- Industrial Linear, Phased, and Annular Arrays.



For further assistance from the Applications Lab, please copy and complete the customer inquiry form and fax it to (717)-242-4170—make extra copies for additional inquiries. You can also phone the Applications Lab at (717)-242-0327 or visit GE Inspection Technologies on the Internet at www.ge.com/inspectiontechnologies

Phased Array Transducers

Principles of Phased Array Transducers

By sequentially firing the individual elements of an array transducer at slightly different times, the ultrasonic wavefront can be focused or steered in a specific direction.

Additionally, electronically phasing the order and sequential firing speeds of an array allows for "sweeping" or "panning" through a selection of beam angles or across an area of inspection without manually manipulating the transducer.



Annular Phased Array



Linear Phased Array



Curved Phased Array

Key Features

- Electronic focal length adjustments.
- Electronic linear scanning.
- Electronic beam steering/angulation.

Key Benefits

- Reduced manual manipulation.
- Reduced scanning surface contact area necessary (footprint).
- Reduced need for multiple inspections with specifically angled or focused probes.
- Increased inspection speed and efficiency.
- Increased coverage of inspection area.

General Specifications

- Frequency: 1 MHz to 7.5 MHz (10 MHz in some cases).
- Piezoelectric material: Proprietary BENCHMARK COMPOSITE®.
- Number of elements: 16–256 elements (application dependent).
- Pitch: 0.2 mm minimum.
- Bandwidth (-6dB): 60% - 80% typical.
- Crosstalk: > 30dB.
- Element sensitivity variation: ± 2 dB.
- Cable options: Detachable connector or potted cable.

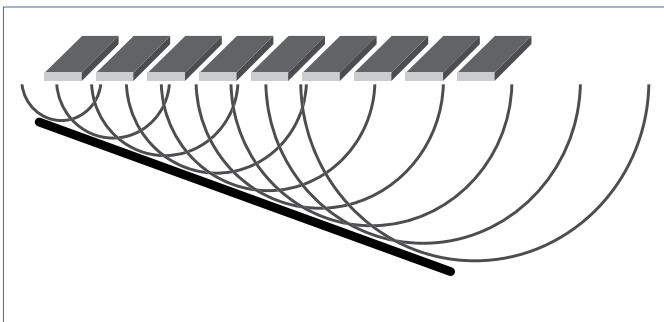

Phased Array Steering

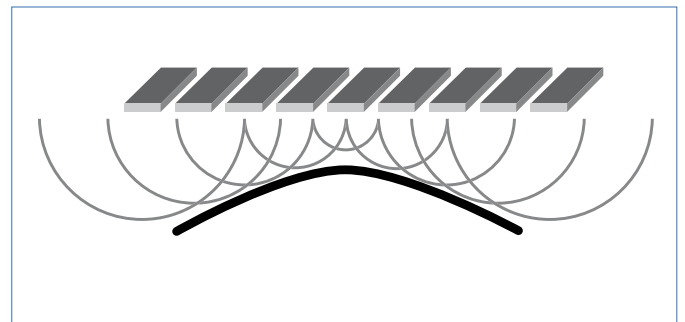

Phased Array Focusing

Accessories

Cables

GE Inspection Technologies offers a complete selection of transducer cables and adaptors with the most commonly used connections. Cables are designed with reinforced connector-cable junctions for long service life. Custom transducer cables and adaptors are available upon request. Call or write for price and delivery.



Description	Length (feet)	Cable Type	Product Codes
BNC to MMD	6.0	RG178	C-047
BNC to MD	6.0	RG174	C-012
BNC to MD	12.0	RG174	C-011
UHF to MMD	6.0	RG174	C-030
LEMO to MD	6.0	RG174	C-022
BNC to Right Angle MD	6.0	RG174	C-033
BNC to BNC	6.0	RG58	C-016
BNC to BNC	12.0	RG58	C-021
UHF to BNC	6.0	RG58	C-027
LEMO to BNC	6.0	RG58	C-018
UHF to UHF (non-waterproof)	6.0	RG58	C-020
UHF to UHF (non-waterproof)	12.0	RG58	C-025
LEMO to UHF (non-waterproof)	6.0	RG58	C-035
BNC to Waterproof UHF	6.0	Belden 8218	C-013
UHF to Waterproof UHF	6.0	Belden 8218	C-029
Dual BNC to MMD	6.0	MD 250-3909	C-014
Dual BNC to MD	6.0	RG174	C-024
Dual UHF to MD	6.0	RG174	C-034
RC Dual to BNC	6.0	RG174	C-088
RC Dual to BNC, Heavy Duty	6.0	RG174	C-089
KBA560V to BNC Dual	6.0	RG174	C-067
HT400A to BNC Dual, Armored	6.0	RG174	C-101
HT400A to BNC Dual, Standard	6.0	RG174	C-102

Special cables available on request.

Adaptors

Type	Description	Product Codes
BNC-UHF	Adapts transducer or instrument with BNC connector to cable with UHF connector	A-025
UHF-BNC	Adapts transducer or instrument with UHF connector to cable with BNC	A-026
LEMO-BNC	*Adapts instrument with LEMO #1 connector to BNC	A-030
STUHF-RA	Right angle adaptor for type STUHF, 3/4" diameter search tube	A-032
UHF-STIF	Adapts transducer with UHF connector to 1.375" flange tpe search tube	A-031
DM-BNC	Adapts LEMO plug on D-meter probe cable to dual BNC connectors	A-045
BNC-BNC	Couples BNC cable to another BNC cable	A-010

Special adaptors available on request.

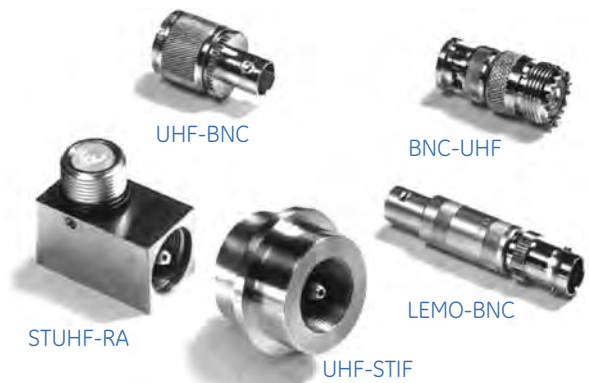

Search Tubes

The STUHF stainless steel immersion search tube has an outside diameter of .735" and is for use with all immersion transducers with UHF (threaded) connectors.



Length (in.)	Product Codes	Length (in.)	Product Codes
1.5	ST-010	12.0	ST-016
2.0	ST-011	18.0	ST-018
3.0	ST-012	24.0	ST-015
4.5	ST-013	36.0	ST-019
6.0	ST-014		

Special lengths available on request.

Accessories

Exosen Couplants (General Purpose)

GE Inspection Technologies Exosen ultrasonic couplant is specially formulated for ultrasonic coupling in all general applications. Exosen is available in five standard viscosities and has the following properties:

- Water soluble.
- Low sulphur and halogens.
- Non-toxic and nonflammable.
- Antiseptic–non-irritating–pleasantly scented–safe.
- High viscosity grades ideal for vertical and overhead surfaces.
- Rust preventative added.
- Shelf life of one year when stored between 50°F and 80°F and out of direct sunlight.

Please order by product code from the table.

Couplant Grade	Equivalent Viscosity	1 gallon	Case of Four 1 gallon	5 gallon	55 gallon
Exosen 10	30 Oil	X-220	X-225	X-240	X-260
Exosen 14	40 Oil	X-320	X-325	X-340	X-360
Exosen 20	90 Oil	X-420	X-425	X-440	X-460
Exosen 30	Heavy Pourable	X-520	X-525	X-540	X-560
Exosen 40	Semisolid			X-640	X-660

Note: MSDS included with each Exosen shipment. Letter of certification available upon request. Empty 8 ounce squeeze bottle included with each gallon of Exosen.

XL Couplant

(Laboratory and Smooth Surfaces)

GE Inspection Technologies XL ultrasonic couplant is specifically made for laboratory testing of transducers and for contact testing of materials having smooth surface finish of 62 microinches RMS or better in both general production and laboratory testing.

Quantity	Product Codes
8 ounce squeeze bottle	XL-820
16 ounce squeeze bottle	XL-840
1 gallon container	XL-860
5 gallon container	XL-880

Note: Letter of certification included with each Hitempo shipment.

SLC Couplant

(Curved, Rough, Vertical, and Overhead Surfaces)

GE Inspection Technologies SLC couplant is a thick highly attenuative couplant ideal for making thickness measurements on very rough surfaces that would not be possible with thinner couplants. Its high viscosity also makes it an excellent couplant for use on vertical and overhead surfaces.

Quantity	Product Codes
4 ounce container	X-080

ZGM Couplant

(High Temperature)

ZGM is a highly viscous, high temperature couplant manufactured by GE Inspection Technologies. It is designed for use on surfaces with temperatures of 400°F (minimum) to 1000°F. Primarily intended for wall thickness measurement, ZGM contains a solid filler that melts at high temperature.

Quantity	Product Codes
100 g. (3.5 oz.) tube	XZ-471

Exosen Couplants

(General Purpose)

GE Inspection Technologies Hitempo is an excellent high temperature couplant for inspection on surfaces at temperatures up to 550°F. Its high viscosity (toothpaste consistency) makes it ideal on vertical and overhead surfaces.

Quantity	Product Codes
2.8 ounce tube	XH-010
Dozen 2.8 ounce tubes	XH-015

Note: Letter of certification included with each Hitempo shipment.

Delay Line, Wedge and Protective Face Couplant

This couplant is for use between the face of the transducer and the delay line, wedge, membrane, or wear cap with which it is used.

Quantity	Product Codes
2 ounce squeeze bottle	XD-740

Accessories

Type DC Block (AWS type)

For shear wave distance calibration. Contains a 1.0" radius overlaying a 2.0" radius on 180° half circle.

Dimensions:

2.0" radius section is .50" thick;

1.0" radius section is 1.0" thick.

Product Code: 118-540-290



Type SC Block (AWS type)

For shear wave sensitivity calibration. Contains two .062" diameter sidedrilled holes. Distance from front surface to center of holes is .178" and .521".

Dimensions: 3.000" x 1.250" x .905".

Product Code: 118-540-330



AWS Resolution Block

For checking resolution capabilities of angle beam transducers. Contains three sets of three .062" diameter thru holes for 45°, 60°, and 70°.

Dimensions: 6" x 3" x 1"

Product Code: 118-540-350



Angle Beam Block (Miniature Size)

Substitute for DSC Block for general angle beam calibration. Contains 1.0" radius opposite a 2.0" radius, and a 5/64" sidedrilled, flat bottom hole .750" deep

Dimensions: 1.0" thick.

Product Code: 118-540-260

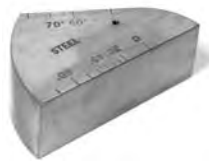

IOW Beam Profile Block (English or Metric)

For beam profile measurement of angle beam transducers and for measurement of transducer angles.

Dimensions: 12" x 3" x 2"

Product Code: 118-540-240



Type DSC Block (AWS type)

For shear wave distance and sensitivity calibration. Contains a 1.0" radius opposite a 3.0" radius. The 3.0" radius includes a radius slot .375" deep x .032" wide. Also contains 0" reference point for checking exit point on wedge, and a .125" diameter side-drilled thru hole and corresponding markings at 45°, 60°, and 70° for measuring actual refracted angle. Dimensions: 1.0" thick

Product Code: 118-540-300



Step Blocks

For Thickness and linearity calibration. Available in 4-step version with thickness of .250", .500", .750", and 1.00"; or 5-step version, with thickness of .100", .200", .300", .400", and .500".

4-Step Product Code: 118-540-320. 5-Step Product Code: 118-540-310



Type DS Block (AWS type)

For longitudinal distance and sensitivity calibration. Contains a 2.0" high section between two 4.0" high sections.

Dimensions: 6.0" x 4.0" x 2.0"

Product Code: 118-540-340



IIW Block Type 1

For calibration of shear and longitudinal transducers, and for verification of shear wedge exit point and refracted angle. Also can be used to check resolution and sensitivity.

Dimensions: 12" x 4" x 1"

Product Code: 118-540-270



IIW Block Type 2

Modified version of original IIW Type 1. Includes a 2.0" radius x .250" deep cut-out and additional side-drilled holes for resolution studies.

Dimensions: 12" x 4" x 1"

Product Code: 118-540-280



NAVSHIPS Test Block

Used in accordance with NAVSHIPS Specification 0900-006-3010. Section 6, for distance amplitude correction, sensitivity levels and flaw depth information.

Contains six 3/64" diameter side-drilled holes at distances from 1/4" to 2 3/4"

Dimensions: 12" x 3" x 1 1/4"

Product Code: 118-540-370



30FBH Resolution Block

For determining resolution and sensitivity capabilities and to produce area/amplitude plots for normal beam transducers.

Contains ten flat bottom holes each of diameters 3/64", 5/64", and 8/64" at test metal distances from .050" to 1250"

Dimensions: 11" x 1 1/2"

Product Code: 118-540-230



ASME-625 Reference Plate

For longitudinal, shear, and surface wave sensitivity calibrations. Contains six flat bottom holes: three 4/64" diameter holes, one each at a depth of .050", .250", and .50", and one 4/64" hole 1.500" deep, one 8/64" hole 1.625" deep, and one 16/64" hole 1.750" deep.

Dimensions: 12" x 6" x 1/2"

Product Code: 118-540-360



Accessories

Test Blocks, continued

Miniature Resolution Block

For checking resolution capabilities and calibrating high resolution test equipment. Contains four 3/16" wide and 5/8" long, milled slots to simulate flat plate reflectors at metal travel distances of .015", .020", .025", and .030", and six flat bottom holes, three each with diameters of 3/64" and 1/64" at metal travel distances of .020", .025", and .030".

Dimensions: 3 5/8" x 1 x 1/8".

Product Code: 118-540-250.

ASME Calibration Blocks

Provided with one flat bottom hole with diameter and depth per specifications. Special Order.

ASTM Distance/Amplitude Block Set

(19 Blocks) All 19 blocks have the same size test hole. Hole size must be specified when ordering (3/64", 5/64", or 8/64"). The metal travel distances, for the set are: 0006, 0012, 0025, 0037, 0050, 0062, 0075, 0087, 0100, 0125, 0175, 0225, 0275, 0325, 0425, 0475, 0525, and 0575.

Product Code: 118-540-028.

ASTM Area/Amplitude Block Set

(8 Blocks) Includes the following blocks: 1-0300, 2-0300, 3-0300, 4-0300, 5-0300, 6-0300, 7-0300, and 8-0300.

Product Code: 118-540-018.

ASTM Distance/Area Amplitude Set

(10 Blocks) Includes the following blocks: 3-0300, 5-0012, 5-0025, 5-0050, 5-0075, 5-0150, 5-0300, 5-0600, 8-0300, and 8-0600.

Product Code: 118-540-019.

Single ASTM Blocks

For measuring the sensitivity and/or resolution of normal beam transducers. Machined to E-127-64 dimension requirements. Available with flat bottom holes from 1/64" to 8/64" diameter, with test metal distances from .062" to 6.00". Prices for other lengths and diameters furnished on request. Block identification is as follows: first digit indicates hole diameter in 64ths, next four digits indicate test metal distance in hundredths of an inch. Therefore, a 3-0050 block would have a 3/64" diameter FBH at .500" TMD. Special Order.



Notes: (Apply to all test blocks)

1. Product codes listed are for steel test blocks only. Please order all steel blocks by product code listed for each type. All other block materials should be ordered on an individual basis by description.
2. Please see price list for ordering and delivery information.
3. GE Inspection Technologies' test blocks are machined to engineering specifications and to precision tolerances from ultrasonically inspected and approved material.
4. All blocks and sets listed include quality hardware cases except single ASTM blocks.
5. Steel blocks are nickel plated unless otherwise requested.

Transducer Certification

Real Time Waveform and Frequency Spectrum

The real time waveform and frequency spectrum certifies the natural, unbiased, unfiltered waveform and the degree of damping and shows the frequency components of the gated signal. A highly damped unit such as an Alpha Series transducer gives optimum resolution while displaying a broad frequency spectrum. This is necessary for thickness gauging of thin materials or when inspecting for near-surface flaws. A transducer that is not as highly damped will have greater penetrating power but less resolution and a narrower frequency spectrum. Product code TC-911

GE Inspection Technologies

Transducer Certificate of Conformity
Compliant to ASTM E-1065 Guidelines

Date:	9/3/2005
Product Code:	112-204-001
Serial Number:	03B Y 2
Description:	PAW-400X PWRAC 50.000MHz

Test Setup:

Test Target: .375" Plexiglas

Energy Impedance: 3
250

UT A S/N: HM00113

UT A Cal Due Date: 5/8/2006

D-scope S/N: 8023004

D-scope Cal Due Date: 10/31/2005

Software: FNT000 Rev. H

Test Data:

Sensitivity(A to dB): -33.80 dB

Pulse Duration@ 20dB: 4.48E-07 Sec

Peak Frequency: 4.70E+06 Hz

Center Frequency: 4.93E+06 Hz

% Bandwidth@ -6dB: 75.0 %

Inspector: JPT

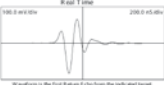

Waveform to the first Return Echo from the indicated target.

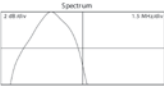

The accuracy of the transducer described above has been confirmed by factory standard test equipment and laboratory reference standards available to the National Institute of Standards and Technology. This facility's Quality System is registered to ISO 9001:2000 and is compliant with: ISO 9001 and NADCAP's SPC 11000.



GE Inspection Technologies, LP
50 Industrial Park Rd.
Lewisburg, PA 17044
Tel: 717.242.0327
Fax: 717.242.2606
GEInspectionTechnologies.com

021-247-287, Rev D

Beam Profile

The beam profile plot is made by moving the transducer across a small rod reflector in an immersion tank. Ball or wire reflectors are also commonly used. The beam profile gives the relative intensity and width of the sound beam at a given distance from the transducer face. Product code TC-913

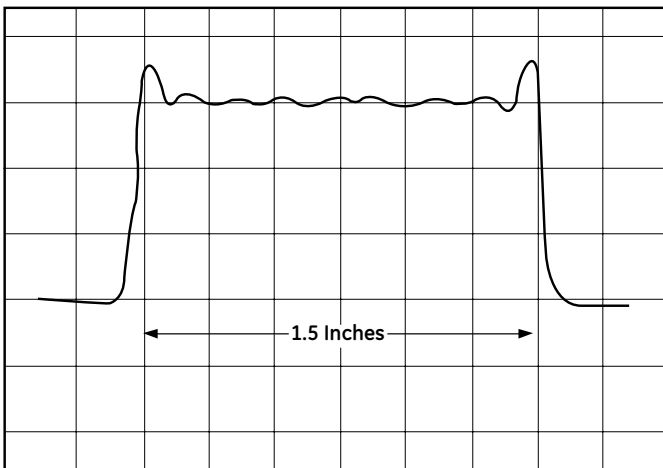

Tables and Formulas

dB vs. Amplitude Ratio Chart

dB	Ratio	dB	Ratio	dB	Ratio	dB	Ratio
0	1.00:1	5	1.78:1	11	3.55:1	17	7.08:1
.5	1.06:1	6	2.00:1	12	3.98:1	18	7.94:1
1	1.12:1	7	2.24:1	13	4.47:1	19	8.91:1
2	1.26:1	8	2.51:1	14	5.01:1	20	10.00:1
3	1.41:1	9	2.82:1	15	5.62:1	40	100.00:1
4	1.58:1	10	3.16:1	16	6.31:1	60	1000.00:1

Near Field Length (N) in Water (Inches)

Frequency (MHz)	Element Ø (inches)			
	1.00	.75	.50	.25
1.0	4.3	2.4	1.07	.27
2.25	9.6	5.4	2.4	.60
5.0	21.4	12.0	5.4	1.3
10.0	43	24	10.7	2.7

To find approx. length in steel, divide the above values by 4.

Velocity and Acoustic Impedance of Common Materials

Material	Longitudinal Velocity		Sheer Velocity		Acoustic Impedance
	$\frac{\text{in.}}{\text{sec.}} \times 10^6$	$\frac{\text{cm.}}{\text{sec.}} \times 10^5$	$\frac{\text{in.}}{\text{sec.}} \times 10^5$	$\frac{\text{cm.}}{\text{sec.}} \times 10^5$	$\frac{\text{gm.}}{\text{cm}^2\text{sec.}} \times 10^5$
Air	.013	.33	-	-	.0004
Aluminum	.25	6.3	.12	3.1	17.0
Aluminum Oxide	.39	9.9	.23	5.8	32.0
Beryllium	.51	12.9	.35	8.9	23.0
Boron Carbide	.43	11.0	-	-	26.4
Brass	.17	4.3	.08	2.0	36.7
Cadmium	.11	2.8	.059	1.5	24.0
Copper	.18	4.7	.089	2.3	41.6
Glass (crown)	.21	5.3	.12	3.0	18.9
Glycerin	.075	1.9	-	-	2.42
Gold	.13	3.2	.047	1.2	62.6
Ice	.16	4.0	.08	2.0	3.5
Inconel	.22	5.7	.12	3.0	47.2
Iron	.23	5.9	.13	3.2	45.4
Iron (cast)	.18	4.6	.10	2.6	33.2
Lead	.085	2.2	.03	.7	24.6
Magnesium	.23	5.8	.12	3.0	10.0
Mercury	.057	1.4	-	-	19.6
Molybdenum	.25	6.3	.13	3.4	64.2
Monel	.21	5.4	.11	2.7	47.6
Neoprene	.063	1.6	-	-	2.1

Material	Longitudinal Velocity		Sheer Velocity		Acoustic Impedance
	$\frac{\text{in.}}{\text{sec.}} \times 10^6$	$\frac{\text{cm.}}{\text{sec.}} \times 10^5$	$\frac{\text{in.}}{\text{sec.}} \times 10^5$	$\frac{\text{cm.}}{\text{sec.}} \times 10^5$	$\frac{\text{gm.}}{\text{cm}^2\text{sec.}} \times 10^5$
Nickel	.22	5.6	.12	3.0	49.5
Nylon, 6-6	.10	2.6	.043	1.1	2.9
Oil (SAE 30)	.067	1.7	-	-	1.5
Platinum	.13	3.3	.067	1.7	69.8
Plexiglass	.11	2.7	.043	1.1	3.1
Polythylene	.07	1.9	.02	.5	1.7
Polystyrene	.093	2.4	.04	1.1	2.5
Polyurethane	.070	1.9	-	-	1.9
Quartz	.23	5.8	.087	2.2	15.2
Rubber, Butyl	.07	1.8	-	-	2.0
Silver	.14	3.6	.06	1.6	38.0
Steel, mild	.23	5.9	.13	3.2	46.0
Steel, stainless	.23	5.8	.12	3.1	45.4
Teflon	.06	1.4	-	-	3.0
Tin	.13	3.3	.07	1.7	24.2
Titanium	.24	6.1	.12	3.1	27.3
Tungsten	.20	5.2	.11	2.9	101.0
Uranium	.13	3.4	.08	2.0	63.0
Water	.0584	1.48	-	-	1.48
Zinc	.17	4.2	.09	2.4	29.6

Useful Formulas

Near Field Length =	$D^2F / 4C$ or $D^2 / 4\lambda$
Beam Spread	$\text{SIN} \gamma = C / DF \times 1.22$ or $1.22\lambda / D$
Snell's Law	$\text{SIN} \alpha / \text{SIN} \beta = C_1 / C_2$
Skip Distance =	$2T \times \text{TAN} \beta$
V-Path =	$2T / \text{COS} \beta$
Surface Distance (Projected) =	$\text{S.P.} \times \text{SIN} \beta$
Depth (1st Leg) =	$\text{S.P.} \times \text{COS} \beta$
Depth (2nd Leg) =	$2T - (\text{S.P.} \times \text{COS} \beta)$
Depth (3rd Leg) =	$(\text{S.P.} \times \text{COS} \beta) - 2T$
Wavelength =	C / F
Frequency =	C / λ
Acoustic Impedance =	$Z = C \times d$
% of Reflected Sound Pressure =	$R_p = (Z_2 - Z_1) / (Z_2 + Z_1)$
Coefficient of Transmission =	$T_p = 2Z_2 / (Z_2 + Z_1)$
Total Beam Width =	$\text{TBW} = (\text{Depth} - N) (2\text{TAN} \gamma) + T \times \text{Element Diameter}$

Transit Time =	$TT = 2T / C$
Center Frequency =	$F_c = (F_1 + F_2) / 2$
% Bandwidth =	$(F_1 - F_2) / F_c \times 100\%$
Q Factor =	$F_c / (F_1 - F_2)$
Circumference of a Circle =	$\pi \times \text{Diameter}$
Distance =	$\text{Speed} \times \text{Time}$
RPM =	$\text{Speed} / \text{Circumference}$
Maximum Scanning Speed (x, y)	$(\text{Min. Flaw Length} + \text{EBW}) \times \text{PRR}$
Maximum Scanning Speed (polar)	$\text{RPM} \times \text{Diameter} \times \text{Clock interval (ft per min.)}$
dB Difference =	$20 \text{ Log } (A_1 / A_2)$
dB Ratio =	$\text{Inv log dB} / 20$
Water Equivalent = (steel)	$WE = F (\text{water}) \times (C(\text{water})) / (C(\text{steel}))$ (F= Focal length)
MAXB =	$\text{SIN}^{-1} (\text{ID} / \text{OD})$
Focal Length =	$R = F (n - 1) / n$
Cylinder Offset Technique	$\text{Offset (X)} = \text{Outside Radius} \times \text{SIN} \alpha$

Symbol Key
λ = Wavelength
D = Probe Diameter
F = Probe Frequency
C = Acoustic Velocity
d = Density
α = Incident Angle
β = Refracted Angle
T = Part Thickness
S.P. = Sound Path
N = Near Field
γ = Divergence 1/2 angle

Transducer Kits

Transducer Kits combine the most popular transducers and accessories necessary for general ultrasonic testing applications. Discount priced and organized in a hard shell carrying case, the kit contents are easily accessible, convenient for storage, and economical.

Basic Contact Kit—Product Code 118-450-020

Contains a wide assortment for weld inspection, lamination detection, corrosion/erosion and thin gauge materials.

Qty.	Product Codes	Description
1	113-292-603	*2.25 MHz, .63" x .63" AWS Style, Single Element
1	113-242-591	2.25 MHz, .5" MSW-QC Style, BMC Single Element Angle Beam Probe
1	113-262-043	2.25 MHz, 1" CR Style, Single Element Contact Probe
1	113-544-000	5 MHz, .5" CA211A Style, Single Element Contact Probe
1	113-252-241	2.25 MHz, .75" PMCR Style, Single Element Membrane Probe

Qty.	Product Codes	Description
1	113-527-660	15 MHz, .25" ALPHA 2 DFR Style, Single Element Delay Line Probe
1	113-292-751	2.25 MHz, .5" x .5" DU-F Style, Dual Element Contact Probe
1	113-224-681	5 MHz, .25" RC Style, Dual Element Contact Probe
1	C-012	BNC-MD Coaxial Cable
1	C-016	BNC-BNC Coaxial Cable
1	C-024	BNC-MD Dual Coaxial Cable
1	C-088	BNC-RC Dual Coaxial Cable

Qty.	Product Codes	Description
1	D-050	Delay Lines for 113-527-660 (10 pcs.)
1	PM-021	Protective Membrane for 113-253-241 (12 pcs.)
1	W-104, 106	45° and 70° Lucite Wedge**
1	W-211, 212, 213	45°, 60° and 70° Lucite Wedge**
1	XD-740	Wedge/Delay Line Couplant
1	118-540-198	5 Step Reference Standard .1"-.5"
1	118-800-020	Hardshell Carrying Case

Basic AWS Weld Inspection Kit Part No. 118-450-500

Contains transducers and accessories required for testing weldments to specification AWS D1.1.

Multi-Purpose Contact Kit Part No. 118-450-510

Contains the most commonly used transducers for a variety of angle beam, lamination, corrosion, general flaw, and thickness testing.

Basic Angle Beam Kit Part No. 118-450-030

Contains an assortment for weld and other angle beam inspections.

Qty.	Product Codes	Description
1	113-292-603	2.25 MHz, .63" x .63" AWS Style, Single Element Angle Beam Probe
1	113-292-601	2.25 MHz, .63" x .75" AWS Style, Single Element Angle Beam Probe
1	113-292-604	2.25 MHz, .75" x .75" AWS Style, Single Element Angle Beam Probe
1	113-262-043	2.25 MHz, 1" dia. CR-RHP, L-Wave Contact Probe
1	W-104	45° Lucite Wedge**
1	W-105	60° Lucite Wedge**
1	W-106	70° Lucite Wedge**
1	C-016	BNC-BNC Coaxial Cable
1	B-196	DSC Reference Standard
1	XL-820	8 oz. Couplant
1	118-800-020	Hardshell Carrying Case

Qty.	Product Codes	Description
1	113-544-000	5 MHz, .5" dia. CA211A Style, Single Element Contact Probe
1	113-262-043	2.25 MHz, 1" dia. CR Style, Single Element Contact Probe
1	113-527-660	15 MHz, .25" Alpha 2 DFR Style, Delay Line Probe
1	113-224-700	5 MHz, .25" dia. ADP Style, Dual Element Probe
1	113-244-591	5 MHz, .5" dia. MSW-QC Style, Benchmark Angle Beam Probe
2	W-211	45° Lucite Wedge**
2	W-212	60° Lucite Wedge**
2	W-213	70° Lucite Wedge**
2	C-016	BNC-BNC Coaxial Cable
2	C-012	BNC-MD Coaxial Cable
1	118-540-198	5 Step Reference Standard, 1"-.5"
1	XL-820	8 oz. Couplant
1	118-800-020	Hardshell Carrying Case

Qty.	Product Codes	Description
1	113-29-642	5 MHz, .18" x .18" ABFP Style, Single Element Angle Beam Probe
1	113-216-585	10 MHz, .125" SMSWS Style, Single Element Angle Beam Probe
1	113-294-600	5 MHz, 5" x 1" SWS Style, Single Element Angle Beam Probe
1	113-224-591	5 MHz, .25" MSWQC Style, Benchmark Single Element Angle Beam Probe
1	118-540-196	DSC Reference Standard
1	C-047	BNC-MMD Coaxial Cable
1	C-016	BNC-BNC Coaxial Cable
1	C-012	BNC-MD Coaxial Cable
1 ea.	W-120, 122	45° and 70° Lucite Wedge**
1 ea.	W-015, 017	45° and 70° Lucite Wedge**
1 ea.	W-201, 202, 203	45°, 60° and 70° Lucite Wedge**
1	XL-820	8 oz. Couplant
1	118-800-020	Hardshell Carrying Case

Transducer Kits

High Temperature Kit

Part No. 118-450-530

Contains dual element delay line, and angle beam transducers for flaw detection at elevated temperatures to 1000°F.

Qty.	Product Codes	Description
1	113-224-760	5 MHz, .25" dia. HT400A Style, Dual Element (1000°F max)
1	113-242-270	2.25 MHz, .5" dia. PWCCS Style, Single Element Delay Line
1	113-292-600	2.25 MHz, .5" x 1" SWS Style, Single Element Angle Beam
1 ea.	W-070, 086	45° and 60° High Temperature Wedge (400°F max)
1	PK-050	High Temperature Delay Line Kit for 2, 42-270 (400°F max)
1	C-016	BNC-BNC Coaxial Cable
1	C-067	Dual MD-BNC Coaxial Cable
1	C-102	BNC-HT400/400A Probe Cable
2	XH-010	2 oz. Tube HITEMPO Couplant (ambient to 550°F)
1	XZ-471	3.5 oz. Tube ZGM Couplant (400-1000°F)
1	118-540-198	5 Step Reference Standard 1"-.5"
1	118-800-020	Hardshell Carrying Case

Basic Immersion Kit

Part No. 118-450-040

Contains an assortment of spherically focused transducers which exhibit good resolution and sensitivity and are ideal for determining which type of transducers are best suited for the testing situation.

Qty.	Product Codes	Description
1	113-127-302	15 MHz, .25" 155 Style Probe with 1.5" Spherical Focus
1	113-136-280	1.0 MHz, .38" 15 Style Probe with 3" Spherical Focus
1	113-254-360	5 MHz, .75" 155 Style Probe with 6" Spherical Focus
1	113-244-280	5 MHz, .5" 155 Style Probe with 2" Spherical Focus
1	118-560-007	UHF RA-UHF Isolated Coaxial Adaptor
1	C-016	BNC-BNC Coaxial Cable
1	A-025	BNC-UHF Adaptor
1	118-800-020	Hardshell Carrying Case

Corrosion Survey Kit

Part No. 118-450-520

Contains the most popular dual element flaw detection transducers for corrosion detection in materials from ambient to 1000°F.

Qty.	Product Codes	Description
1	113-224-700	5 MHz, .25" dia. ADP Style Dual Element Probe
1	113-544-210	5 MHz, .375" dia. KBA560 Style, Dual Element Probe (450°F max)
1	113-224-760	5 MHz, .25" dia. KBA-HT400A Style
1	113-292-751	2.25 MHz, .5" x .5" DU-F Style, Dual Element Probe
1	113-244-241	5 MHz, .5" dia. PMCR Style, Single Element Membrane Probe
1	C-067	BNC-KAB560 Coaxial Cable
1	C-016	BNC-BNC Coaxial Cable
1	C-024	BNC-MD Coaxial cable
1	C-102	BNC-HT400/400A Probe Cable
2	XH-010	2 oz. Tube HITEMPO Couplant (ambient to 550°F)
1	XZ-471	3.5 oz. Tube ZGM Couplant (400-100°F)
1	118-540-198	5 Step Reference Standard, 1"-.5"
1	XD-740	Wedge/Delay Line and Membrane Couplant
1	118-800-020	Hardshell Carrying Case

**Refracted angle in carbon steel @ 70°F.

Couplant Solutions Catalog

EchoPure™

The most universal water-soluble UT couplant

Operating Range: -60° to 350°F / -51° to 176°C

- Couplant of choice for phased array manual inspections (PAMUT)
- Complies with P91 steel requirement for water-free couplant
- Ideal for very cold and very warm inspection
- Four viscosities (fluids and gels)
- Very slow drying
- All ingredients approved for incidental food contact
- Water-free / water-soluble



EchoTrack™ A

Broadest operating range and slowest evaporation rate in a water-based, high performance couplant

Operating Range: -10° to 200°F / -23° to 93°C

- Slow drying
- Compatible with most materials
- Medium & high viscosity
- No nitrates, nitrites, glycol ethers or formaldehyde
- Water-soluble



EchoTrack™

Lowest price, high performance UT couplant

Operating Range: 18° to 180°F / -8° to 82°C

- Medium & high viscosity
- No nitrates, nitrites, glycol ethers or formaldehyde
- Water-soluble
- Acrylic polymer, least residue



UltraSonix™

High performance – Aircraft grade

Operating Range: 10° to 220°F / -12° to 104°C

- Glycerin-free – meets FAA AC 25-29 requirement of no glycerin for aluminum inspections
- Compatible with most materials
- Medium & high viscosity
- No nitrates, nitrites, glycol ethers or formaldehyde



Sonix™

Best choice for a low-cost general purpose ultrasonic couplant

Operating Range: 18° to 120°F / -8° to 50°C

- Strong coupling film, salt stable
- Good ferrous corrosion inhibition
- No nitrates, nitrites, glycol ethers or formaldehyde
- Water-soluble



ECONOgel™

Lowest cost water-soluble ultrasonic couplant

Operating Range: 26° to 120°F / -3.3° to 48°C

- Strong coupling film, salt stable
- Good ferrous corrosion inhibition
- No nitrates, nitrites, glycol ethers or formaldehyde
- Water-soluble



Glycerin

GE Approved Glycerol, Batch 205 for CFM56-7B engine fan blades

Operating Range: 65° to 500°F / 18° to 260°C

- Packaged from USP glycerin, 99+%
- Higher acoustic impedance
- Will not harden on equipment
- Pumpable fluid
- Compatible with plastics

Echo Shear Wave™

Transmits normal incidence shear wave

Operating Range: 40° to 90°F / 4° to 32°C

- Water-soluble
- Easily removed with water wash
- Low toxicity, non-irritating

Echo 8 ZH™

For flow metering and long term monitoring at elevated temperatures

Operating Range:

Short Term: -45° to 750°F / -42° to 398°C
Long Term: -45° to 400°F / -42° to 204°C

- Enhanced acoustic impedance
- Reduces surface roughness acoustic noise

Echo Z+™

High acoustic impedance

Operating Range: 0° to 200°F / -18° to 93°C

- Ideal for rough surfaces and concrete
- Very high viscosity
- Excellent ferrous corrosion inhibition

Phased Array Couplants

Forever Wedge™

- Facilitates more reproducible inspections, less artifacts and longer wedge coupling.
- High viscosity fluid couplant for use between phased array and angle beam transducers and the wedge.

EchoPure™

- Reduces noise and artifacts from couplant failure between the wedge and the test object.
- Eliminates dry spots under the wedge.
- See ABOVE for more information

Powder Couplants

EchoMix® Powder

Operating Range: 32° to 120°F / 0° to 50°C

- Easily mixed in water
- Salt resistant
- No formaldehyde
- Compact for shipping & storage



EchoMix®

- 2-part (two packets)
- Strongest coupling film
- Blue mixing tracer

EchoMix® Clear

- 2-part (two packets)
- No blue tracer

EchoMix® Single

- 1-part powder
- Easiest mixing
- Blue mixing tracer

High Temperature Couplants

Operating range printed on every label

VersaSonic®

Lowest cost, multiple viscosities

Operating Range: -10° to 700°F / -23° to 371°C

Auto Ignition: 788°F

- Fast response, no wait time
- No plastic polymers
- Low toxicity
- Non-irritating
- Three viscosities: fluid, medium and high viscosity gel
- Does not contain peanut oil



HiTempco

No residue, fast response

Operating Range: -50° to 775°F / -45° to 412°C

Auto Ignition: 820°F

- Fast response, no wait time
- No residue or varnish
- Less smoke than VersaSonic
- No plastic polymer or char
- Excellent corrosion inhibition
- Non-toxic, non-irritating



EchoTherm™

Lowest cost for use above 800°F

Operating Range: 200° to 1000°F / 93° to 538°C

Auto Ignition: 1300°F

- Less expensive couplant for use over 800°F and in inspection ports
- Ultra-high temperature
- Contains a plastic polymer which delays response time 2 seconds
- Leaves plastic residue (char)



EchoTherm Extreme™

The best – no residue, instant, stable response to 1250°F

Operating Range: -40° to 1250°F / -40° to 675°C

Auto Ignition: 1300°F

- Ultra-high temperature
- Fast response, no wait time
- No plastic polymer
- No plastic char residue
- Broadest operating range
- Low smoke



Fluid Couplants

Echo 8HT™

Most universal AUT fluid

Operating Range: -50° to 800°F / -45° to 425°C

Auto Ignition: 850°F

- Pumpable fluid
- Three viscosities (Grades 1, 4 & 10)
- Little or no residue
- Low toxicity
- Non-irritating



SpectrumGlide™

Highest performance AUT fluid

Operating Range:

Thickness Gaging: -50° to 730°F / -45° to 387°C

Flaw Detection: 0° to 600°F / -17° to 315°C

Auto Ignition: 752°F

- Least run off of all pumpable fluids
- Minimal residue
- Low toxicity
- Non-irritating



EchoPure Fluid™

Operating Range: -60° to 350°F / -51° to 176°C

- Best for very low to ambient temperatures
- Water-soluble (does not form oil slick)
- Least expensive fluid couplant
- Lowest viscosity fluid



ECHO
ultrasonics

The
couplant
experts



DETEK

6805 Coolridge Drive

Temple Hills, MD 20748-6940

301-449-7300 FAX 301-449-7011

www.detek.com email: sales@detek.com



NONDESTRUCTIVE TESTING EQUIPMENT

SONOTECH

ULTRASONIC COUPLANTS



**6805 COOLRIDGE DR ■ TEMPLE HILLS MD 20748
301-449-7300 ■ 800-638-0554 ■ FAX 301-449-7011**

EMAIL: sales@detek.com

Industry Standard Series

The Industry Standard Series of water-based couplants features high surface wetting capabilities to optimize transmission on dirty or oily surfaces. Ferrous corrosion inhibition factors for each are the highest in their performance class. The Industry Standard Series meets nuclear specifications for Halogens, Sulfur and low melting point metals and many aircraft and military specifications. The following products have established the standard by which other UT couplants are judged.

ULTRAGEL® II NSN 6850-01-157-4348 **The Performance Standard**

A gel couplant for use in ultrasonic inspections where corrosion inhibition is an important criterion and Halogens, Sulfur and low melting point metals must be kept to a minimum.

Since 1976, Ultragel II has been the NDT industry's most specified and used ultrasonic couplant because of its outstanding acoustic performance, chemical characteristics and corrosion inhibition. Ultragel II is ideal for flaw detection, thickness gaging, flow metering and acoustic emission testing from -10° to 210°F.

Ultragel II contains a ferrous corrosion inhibitor with a relative effectiveness rating of 90 (p15 & 16), meets a range of ASTM, military and industry specifications partially summarized below, and is compatible with most metals except magnesium. See Gel 3000 for Mg compatible couplant. (p12)



Tested and Approved:

ASTM: F519 Hydrogen Embrittlement Testing on high strength steel, F945 Stress Corrosion Cracking Testing on Titanium alloys

Boeing Specifications: BAC 5968 (adhesive bonds), 5980 (composites), 5439-PSD622 (welds, tubing and wrought material)

Pratt & Whitney: PWA 36604, MCL E-205 Type II (ASTM F945), PWA 36700/36604 Hot corrosion testing on high temperature alloys AMS 5544 (Waspalloy), 5536 (Hastelloy X), 6359 (Ferrous based alloys) 4037 (Aluminum), 5608 (Haynes 188), 5508 (Greek Ascology), 4375 (Magnesium), PWA 286 & 275 (Gas turbine blade coatings), 1484 PWA turbine blade alloy

Ultrasonic Couplant Storage

Couplant should be stored in the original container above freezing and out of direct sunlight. Once opened, the container must be closed when not in use. Never put unused couplant back into the original container. If pumps or valves are used on bulk couplant, wash thoroughly between drums to avoid contamination of new product.



DETEK

6805 Coolridge Drive
Temple Hills, MD 20748-6940
301-449-7300 FAX 301-449-7011
www.detek.com email: sales@detek.com

Industry Standard Series

SONOTRACE®

For use in ultrasonic inspection where a *glycerine-free couplant* is required.



Sonotrace is a moderately priced, ambient temperature (25° to 175°F), water-based, glycerine-free couplant for flaw detection and thickness gaging where Halogens, Sulfur and low melting point metals must be kept to a minimum. Available in three viscosities from low viscosity fluid to very high viscosity gel.

Sonotrace contains a ferrous corrosion inhibitor with a relative effectiveness rating of 80 (p15 & 16) and is compatible with most composites and metals.

Tested and Approved:

Boeing Specifications: BAC 5968 (adhesive bonds) and BAC 5980 (composites).

ECHOGEL®

A *glycerine-free couplant* for use in inspection where *salt cake or metal corrosion salts* are present.

An industry standard since 1974, Echogel is an economically priced, glycerine-free couplant for flaw inspection in volume use at ambient temperatures from 27° to 140°F. Echogel resists viscosity breakdown on salt-caked boiler and corroded surfaces.

Echogel contains a ferrous corrosion inhibitor with a relative effectiveness rating of 65 (p15 & 16) and is compatible with most composites and metals.

Tested and Approved:

ASTM F519 Hydrogen Embrittlement Testing on high strength steel

Boeing Specifications: BAC 5439-PSD622

NAVSHIPS MIL-STD 767, 2041

ECHOGEL® XP

Extended Performance

Slow drying, glycerine-free couplant recommended for extended temperature range (5° to 190°F), or where slow drying is desired in flaw inspection on salt-caked boiler surfaces, corroded pipe or structural steel.

Echogel XP is an economically priced, glycerine-free couplant with a longer drying time designed for volume flaw detection over extended temperature ranges. Echogel XP resists viscosity breakdown on salt-caked boiler surfaces and corroded metals. Echogel XP contains a ferrous corrosion inhibitor with a relative effectiveness rating of 80 (p15 & 16) and is compatible with most composites and metals.



Tested and Approved: ASTM F519-05 Hydrogen Embrittlement Testing on high strength steel.



DETEK

6805 Coolridge Drive

Temple Hills, MD 20748-6940

301-449-7300 FAX 301-449-7011

www.detek.com email: sales@detek.com

Environmentally Benign Couplant Series



Environmental Awareness

Sonotech developed environmentally benign couplants to minimize the impact of NDT on the environment. These environmentally benign couplants contain biodegradable materials safe for leave-on applications. Sonotech's environmentally benign couplants have low skin irritation potential, contain no dye or fragrance and will not stain clothing.

The Environmentally Benign Couplant Series meets nuclear power specifications for Halogens, Sulfur and low melting point metals. These couplants contain an environmentally benign ferrous corrosion inhibition system for steel. When ferrous corrosion is the most important criterion, Ultragel II and Sonotrace provide superior corrosion inhibition.

SONOGLIDE® UP (Ultra Pure)

Compatible with titanium, aluminum, copper, stainless steel, plastics, many magnesium alloys, and many composites.

Select when Halogens and Sulfur must be at a minimum, broad material compatibility, slow drying, water wash removability and a broad temperature range (-60° to 250°F) are desired.

Tested and Approved:

Pratt & Whitney: PWA 36604, MCL E-205 Type II, ASTM F945 Stress Corrosion Cracking testing on Titanium Alloys, PWA 36700/36604 Hot corrosion testing on high temperature alloys AMS 5544 (Waspalloy), 5536 (Hastelloy X), 6359 (Ferrous based alloys), 4037 (Aluminum), 5608 (Haynes 188), 5508 (Greek Ascology), 4375 (Magnesium), and PWA 286 & 275 (Gas turbine blade coatings), and 1484 PWA turbine blade alloy

SONOGLIDE® FE

For use with cast iron, steel and its alloys.

SonoGlide FE is a special grade of SonoGlide developed for **ferrous metals** where short-term corrosion is a concern. SonoGlide FE performs over a wide temperature range (-60° to 250°F) and is slow drying. SonoGlide FE remains stable on corroded or salt covered surfaces.

Corrosion Inhibition: There is low short-term corrosion potential with SonoGlide FE on cast iron, steel, and its alloys. SonoGlide contains a ferrous corrosion inhibitor with a relative effectiveness rating of 75 (p15 & 16).



DETEK

6805 Coolridge Drive
Temple Hills, MD 20748-6940
301-449-7300 FAX 301-449-7011
www.detek.com email: sales@detek.com

Environmentally Benign Couplant Series

Ambient Temperature Couplants

SOUNDSAFE® & SOUNDSAFE® HV (High Viscosity)

The Environmental Standard NSN 6850-01-157-4348

A high performance couplant for use in overhead, vertical and horizontal applications where environmental concerns are a primary consideration.

Soundsafe offers the highest performance of the environmentally benign family of couplants. Soundsafe has a high humectant level to slow drying, increase acoustic impedance and provide transducer lubrication, and has a temperature range of 0° to 200°F.



Soundsafe Tested and Approved:

Pratt & Whitney: PWA 36604, MCL E-205 Type II or ASTM F945 Stress Corrosion Cracking Testing on titanium alloys, PWA 36700/36604 Hot corrosion testing on high temperature alloys AMS 5544 (Waspalloy), 5536 (Hastelloy X), 6359 (Ferrous based alloys) 4037 (Aluminum), 5608 (Haynes 188), 5508 (Greek Ascoloy), 4375 (Magnesium), PWA 286 & 275 (Gas turbine blade coatings) and 1484 PWA turbine blade alloy

Both Soundsafe and Soundsafe HV contain a ferrous corrosion inhibitor with a relative effectiveness rating of 75 (p15 & 16) and are compatible with most composites and metals except magnesium.

SOUNDCLEAR®

A good price to performance ratio couplant for flaw detection and thickness gaging where environmental concerns are a primary consideration. Fills depressions in rough surfaces.

Soundclear contains humectants to slow drying, increase acoustic impedance and provide an operating temperature range of 20° to 200°F.

Soundclear contains a corrosion inhibitor for steel with a relative effectiveness rating of 45 (p15 & 16) and is compatible with aluminum, titanium, and plastics. Not recommended for magnesium.



DETEK

6805 Coolridge Drive
Temple Hills, MD 20748-6940
301-449-7300 FAX 301-449-7011
www.detek.com email: sales@detek.com

Environmentally Benign Couplant Concentrates



Environmentally Benign Couplant Concentrates are cost effective powders that are to be mixed with water at the inspection site. The compact and lightweight packets are easy to transport or store against unanticipated shortages.

UT-X and UT-X FE Powders are supplied in a two packet system to provide homogenous distribution of antimicrobial agents and corrosion inhibitors and to minimize air during mixing.



UT-X® POWDER

The most economical couplant, mix on site.

UT-X Powder is a couplant concentrate useful for flaw detection and thickness gaging. UT-X Powder resists viscosity breakdown from salts and has a ferrous corrosion inhibition rating of 10. (p15 & 16) For increased ferrous corrosion inhibition, select UT-X FE.

UT-X® FE POWDER

An economical, mix on site couplant for use where ferrous corrosion inhibition is required.

UT-X FE Powder is a couplant concentrate useful for flaw detection and thickness gaging. UT-X FE Powder incorporates a ferrous corrosion inhibitor, a preservative, and a viscosity building polymer. UT-X FE has a ferrous corrosion inhibition rating of 40. (p15 & 16)

UT-X Powders Storage & Shelf Life

UT-X and UT-X FE Powder couplants should be stored in the original zip-top bags out of sunlight. Once opened and prepared, store mixed couplant in a closed container.

The shelf life for unopened packets of UT-X Powder couplants is three (3) years from the date of manufacture. A prepared container of UT-X Powder has an approximate shelf life of one (1) month.

Cost Effective

- Costs significantly less than standard couplants
- Minimizes shipping charges
- Reduced storage requirements
- No drum disposal expense

Easy to use

- Pre-measured 1-gallon and 5-gallon packets
- Extremely compact storage: A drum's volume can fit in a drawer or briefcase
- Viscosity can be varied for exact job requirements simply by adjusting the amount of water
- Mixes quickly, uniformly and without lumps



DETEK

6805 Coolridge Drive
Temple Hills, MD 20748-6940
301-449-7300 FAX 301-449-7011
www.detek.com email: sales@detek.com

Specialty Couplants



HIGH Z

A very high acoustic impedance couplant which optimizes acoustic transmission and reduces surface noise on curved, rough, pitted or heavily corroded surfaces.

Provides the highest acoustic impedance of all Sonotech couplants, reducing surface noise and improving coupling performance on rough and curved surfaces. Many times, High Z will facilitate flaw inspection or thickness gaging when no other couplant will function. Available in two viscosities.



SHEAR GEL®

For use in true shear wave applications.

Provides coupling for shear wave generated by **normal incidence** (zero degree) shear wave transducers.



GEL 3000®

A water-soluble couplant with a fluorescent tracer to assure complete application and/or removal in flaw detection and thickness gaging over a broad temperature range.

Developed to test the space shuttle, Gel 3000 contains a fluorescent tracer that enables the inspector to monitor transducer overlap and ensure complete coverage and removal by illumination with ultraviolet light. Gel 3000 is water and humectant-free, enables testing verification and is available in a range of viscosities.

Gel 3000 has excellent corrosion inhibiting characteristics on most metals including magnesium, and has a ferrous corrosion inhibition rating of 95.

(p15 & 16)



THERMASONIC®

For use where rapid wetting, slow drying, broad temperature range and easy water removal are required.

Thermasonic is a water and humectant-free formula for flaw detection and thickness gaging where water solubility is required. Thermasonic, like Gel 3000, has excellent corrosion inhibiting characteristics on most metals.



DETEK

6805 Coolridge Drive
Temple Hills, MD 20748-6940
301-449-7300 FAX 301-449-7011
www.detek.com email: sales@detek.com

Extended and Extreme Temperature Couplants



Selection Tip

To achieve the most consistent results, select the couplant having the broadest temperature range overlap with the expected test temperature. For example, at 600°F (315°C) Pyrogel® will give the most consistent results, even though several other products will work at this temperature.

What to Expect

Smoke: All liquids and greases decompose above a certain temperature. Smoke does not mean that the couplant is not working, but does indicate that effective coupling time is limited.

Evaporation: At high temperatures couplants dry relatively quickly; the temperature range for flaw detection is narrower because of this evaporation. More couplant may be required near the upper temperature limit to compensate for drying.

Clean up: Wipe still hot transducers on a dry rag folded into several layers to protect skin. Clean room temperature oily residues with common solvents such as acetone, if required. (Do not use solvents on hot pipes!)

Flash Point vs. Auto-Ignition

Auto-Ignition is the temperature at which a substance ignites without other sources of energy. This is usually the temperature of interest in UT inspections, as inspections are seldom done in the presence of spark or flame.

The **Flash Point** of a product is the lowest temperature at which vapors arising from the product will ignite momentarily when exposed to a flame.

Selection and Use Tips

- Pyrogel and Sono 600 are available in low viscosities to enable pumping of couplant to remote transducers in crawlers.

- When testing on vertical surfaces, a thicker grade of couplant is more likely to stay in place. A thinner grade generally gives better performance on flat surfaces.

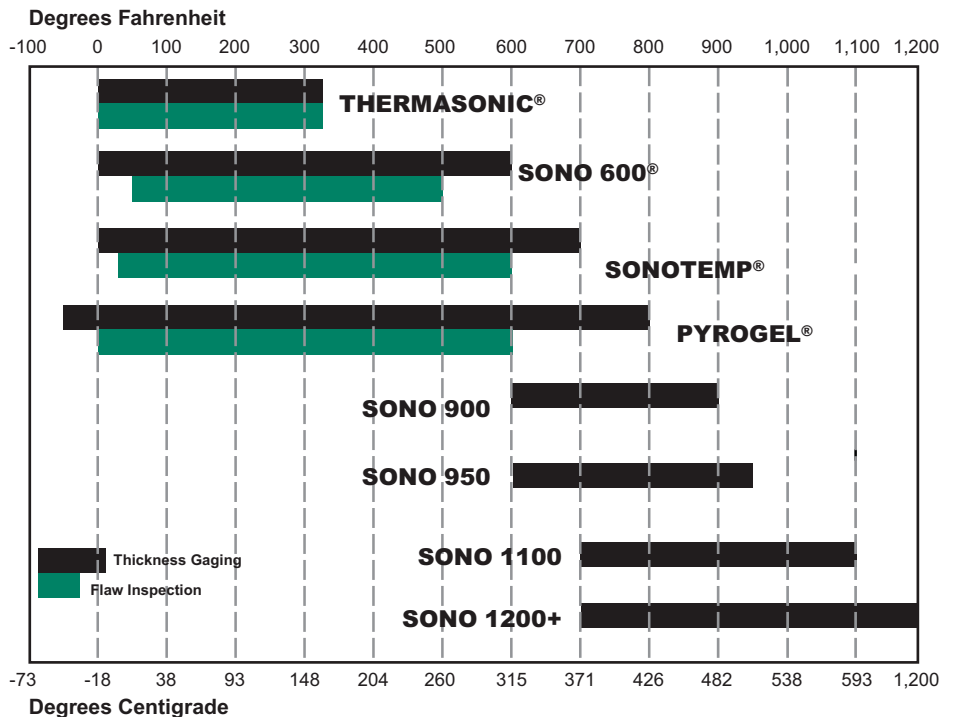

DETEK

6805 Coolridge Drive
 Temple Hills, MD 20748-6940
 301-449-7300 FAX 301-449-7011
www.detek.com email: sales@detek.com

Extended and Extreme Temperature Couplants

Sonotech manufactures a wide variety of couplants with proven performance in flaw detection, thickness gaging, flow metering, and acoustic emission testing at extreme temperatures.



THERMASONIC®

Water-free formula for flaw detection, thickness gaging, flow metering, and acoustic emission testing where long inspection time and/or water solubility are required. 0° to 325°F

Polymer Fume Fever

Sonotech couplants do **NOT** contain perfluorocarbons found in many "high temperature" greases. "Polymer fume fever" is not an operator hazard with Sonotech Couplants.



SONO 600

Biodegradable formula for flaw detection, thickness gaging, and acoustic emission testing in petrochemical, power generating industries, food processing machinery, and pharmaceutical manufacturing and storage equipment. 0° to 600°F



PYROGEL®

Provides coupling over a wide temperature range for thickness gaging, flow metering, acoustic emission testing, and flaw detection. -50° to 800°F



SONO TEMP®

Useful in high temperature thickness gaging and flow metering where elevated temperature, curved or very rough surfaces present coupling difficulties. Sonotemp is our highest acoustic impedance high temperature couplant. 0° to 700°F



SONO 900

A thick, gritty, stay in place paste for thickness gaging. Used worldwide since 1977. 600° to 900°F



SONO 950

Sono 950 will maintain acoustic coupling to give ample time for obtaining good thickness readings at temperatures between 600° and 950° Thinner, smoother consistency than Sono 900.



SONO 1100

Sono 1100 will maintain acoustic coupling to give ample time for obtaining good thickness readings from 700° to 1100°F



SONO 1200+

Provides coupling for thickness gaging from 700° to well over 1200 °F



DETEK

6805 Coolridge Drive
Temple Hills, MD 20748-6940
301-449-7300 FAX 301-449-7011
www.detek.com email: sales@detek.com



PHASED ARRAY TEST BLOCKS

PACS™ Block



New Phased Array calibration block used for angle beam verification, probe angle exit point, calibration for wedge delay, sensitivity, DAC/TCG for thicknesses up to 2", and crack sizing. The three radii (0.200", 1.000", and 2.000") allow for velocity and sound path calculations. Block contains five holes at 3/64" diameter drilled through the 1.000" width, located at .100, .200, .400, .600, .800, 1.200, 1.400, 1.600, 1.800, and 1.900" from the respective scanning surface. Generous hole spacing eliminates "ghost" images from adjacent holes. Also includes an engraves scale from 30° to 70° associated with the .800" hole. Dimensions: 18.0" x 2.0" x 1.0"

Mini PACS™ Block



Mini PACS™ Block is a smaller, portable version of the original PACS™ Block. The block includes a total of four holes at 3/64" diameter drilled through the 1.000" width, located at .200, .400, .600, .700, .800, .900, 1.100, and 1.300" from the respective scanning surface. Dimensions: 1.500" tall x 1.000" wide x 10.00" long.

PACS™ Notch Block



The PACS™ Notch Block has been specially designed for use with Phased Array instruments used for sizing of OD and ID-connected cracks. The block contains four EDM slots at depths of 20, 40, 60, and 80% and a width of .031". Standard thickness is 1.000"; however, other sizes can be ordered. Dimensions: 1.000" thick x 2.000" wide x 7.00" long.

ASTM E2491 PA Assessment Block



The PH Tool ASTM E2491 Phased Array Assessment Block is a general purpose Phased Array calibration block used for beam characterization and evaluation of system performance characteristics. Use it as baseline block to determine long-term instrument performance changes, generate DAC curves, and evaluate linear/angular resolution, focusing ability and beam steering capability. With a variety of targets, this small, lightweight block is also perfect for customer demonstrations of phased array ultrasonics capabilities. This block is also referred to as a "Type B" block. Dimension: 150mm x 100mm x 25mm. In accordance with ASTM E2491.



Phased Array Type A Block (IIW-Type)



The Phased Array "Type A" Calibration Block is used during the initial setup and calibration of a phased array ultrasonic unit. This block can be used to perform tasks such as beam angle verification, calibration for wedge delay, sensitivity calibration, performing DAC/TCG, and more. This block has similar dimensions to an IIW-Type Block, but has been

specially-engineered for phased array applications. Blocks include both 50.0mm and 25.0mm radii, (19) through holes at 1.0mm diameter, (1) through hole at 2.0mm diameter, (4) FBHs at 2.0mm diameter x 2.0, 4.0, 6.0, and 8.0mm deep, (4) FBHs at 4.0mm diameter x 1.0, 3.0, 5.0, and 7.0mm deep, (3) FBHs at 2.0mm diameter x 3.0mm deep machined into the 25mm radius, and (4) EDM notches at 0.1, 0.2, 0.3, and 0.4mm deep x 0.5mm wide x 25.0mm long. Block dimensions are 25.0mm thick x 100.0mm tall x 300.0mm long.

Phased Array Calibration Block No. 2



This new Phased Array calibration block contains all of the required features on the ASME Section V, Article 4 Basic Calibration Block yet spaces the holes out on a longer, narrower block. The block contains three holes at 3/32" diameter drilled through the 1.500" width,

located at 114T, 112T, and 3/4T. It also contains two EDM notches at 2% deep x .010" wide x 1.500" long on opposite surfaces of one end. Dimensions: 14.0" x 1.5" x .75" thick.

Phased Array NAVSHIPS Block



This special Phased Array version of the popular NAVSHIPS block solves the problem of too many holes interfering with one another. The block contains four holes at 3/64" diameter drilled through the 1.250" width. The holes are located at .250, .750, 1.250, 1.750, 2.250, and 2.750".



NONDESTRUCTIVE TESTING EQUIPMENT

ULTRASONIC CALIBRATION BLOCKS



6805 COOLRIDGE DR TEMPLE HILLS MD 20748
301-449-7300 800-638-0554 FAX 301-449-7011
EMAIL: sales@detek.com

DETEK provides a full line of calibration blocks to all American standards and International Institute of Welding (IIW).

Standard blocks are readily available fabricated from:

Aluminum	7075-T6	(Clear Anodized)
Steel	A36, 1018 or 4340 VM	(Nickel Plated)
Stainless Steel	Type 304	

All raw material is ultrasonic inspected prior to manufacture of blocks.

Many other materials are kept on shelf and available for immediate fabrication to customer specifications. All blocks are available in metric geometry.

Blocks are precision manufactured to tolerances well within the allowable limits of their respective codes. All blocks pass a comprehensive quality control inspection in accordance with ISO 9002 (formerly Mil I 45208A) with instruments calibrated in accordance with ANSI/NCSL Z540 (formerly MIL C 45662-A) and traceable to the National Institute of Standards and Technology (NIST).

All blocks are permanently engraved with:

- Degree marks and numbers,
- Block identifications,
- Material and,
- Serial numbers

Handsome, durable hardwood cases are available for all standard blocks.

In addition to blocks illustrated here, DETEK provides the full line of Calibration Blocks to many other specifications such as MIL-STD- 2154 and McDonnell Douglas 21211.3 are also available.

DETEK also has wire and plunge type E.D.M. capabilities and can give prompt turnaround for customer notch and slot standards.

TABLE OF CONTENTS

DSC	2
DS	2
DC	3
ANGLE BEAM	3
AWS RESOLUTION	4
SC	4
IIW TYPE 1	5
IIW TYPE 2	5
MINI IIW	6
ASME-N-625 REFERENCE PLATE	6
30 FBH RESOLUTION BLOCK	7
Navsea T 9074-AS-GIB-010/271 (FORMERLY NAVSHIPS 0900-006-3010 SEC. 6 &MIL STD 271 F)	7
IOW BEAM PROFILE	8
STEP BLOCKS	8
MINIATURE RESOLUTION BLOCK	9
ASME BASIC	9
ASTM-E-127; ASTM-E-428	10, 11
EDDY CURRENT BLOCKS	12

Block Type:
DSC

Application:
Shear wave distance and sensitivity calibration.

Geometry:
1" thick, 4" long with 1" radius and 3" radius. Contains a 1/2" deep X 1/32" radius notch and a 1/8" diameter side drilled hole for 45°, 60°, and 70°.

Per AWS and ASTM-E-164

Standard Materials:

Aluminum 7075-T6	P/N UTB-301
Steel A36/ 1018	P/N UTB-300
Stainless Steel 304	P/N UTB-302

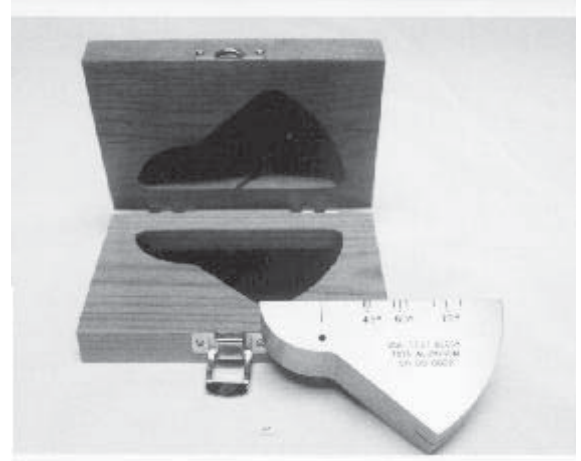

Case for DSC Block P/N UTB-303

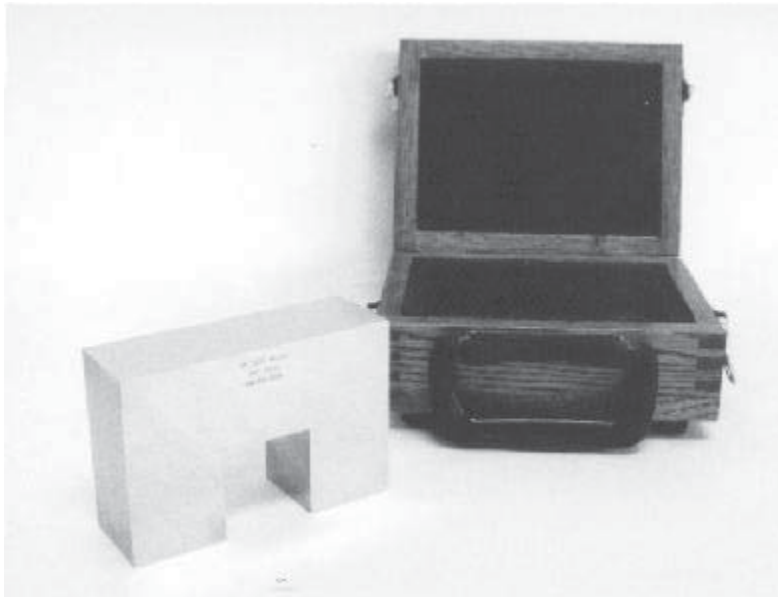

Block Type:
DS

Application:
Distance and sensitivity.

Geometry:
2" x 2" x 6" with a 2" wide cutout. Per ANSI/ AWS

Standard Materials:

Aluminum 7075-T6	P/N UTB-311
Steel 1018	P/N UTB-310
Stainless Steel 304	P/N UTB-312

Case for DS Block P/N UTB-313

Block Type:
DC

Application:
Distance Calibration (shear wave)

Geometry:
1" radius overlying 2" radius on
180° half circle. Per AWS and
ASTM-E-164

Standard Materials:

Aluminum 7075-T6	P/N UTB-101
Steel 1018	P/N UTB-100
Stainless Steel 304	P/N UTB-102
Case for DC block	P/N UTB-103



Block Type:
Angle Beam

Application:
Angle Beam Calibration (Rompas)

Geometry:
 $\frac{1}{2}$ " or 1" thick, 1" radius opposite 2" radius with $\frac{5}{64}$ " diameter by $\frac{3}{4}$ " deep flat bottom hole (1" thick only).

Per ASTM-E-164 and
U.S.A.F.T.O. 33B-1-1 (6-1-84)

Standard Materials:

Aluminum 7075 T-6	P/N UTB-901
Steel A36/ 1018	P/N UTB-900
Stainless Steel 304	P/N UTB-902
Case for angle Beam Block	P/N UTB-903

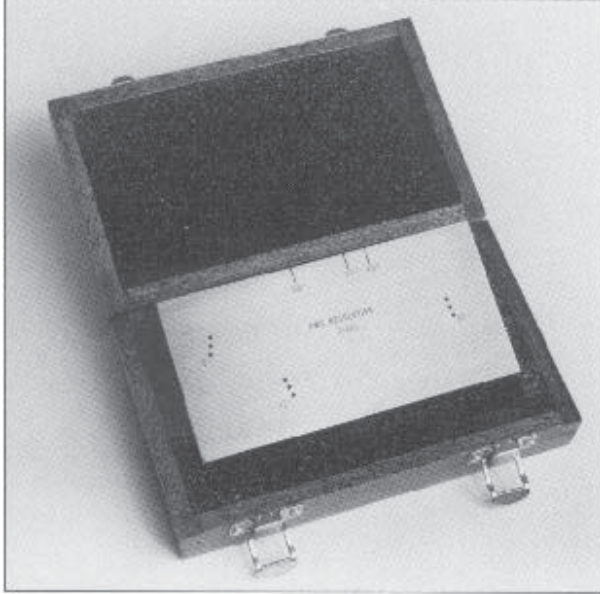

Block Type:
ANSI/ AWS RESOLUTION

Application:
 Checking resolution capabilities of angle beam transducers.

Geometry:
 1" x 3" x 6". Contains nine .062" diameter holes for 45°, 60°, and 70°. Per AWS and BPR

Standard Materials:

Aluminum 7075 T-6	P/N UTB-401
Steel A36 / 1018	P/N UTB-400
Stainless Steel 304	P/N UTB-402
Case for AWS Block	P/N UTB-403

Block Type:
SC

Application:
 Sensitivity Calibration
 (Shear wave)

Geometry:
 .905" x 1.25" x 3"
 Contains two .062" diameter side drilled holes.
 Per AWS / ASTM-E-164

Standard Materials:

Aluminum 7075-T6	P/N UTB-201
Steel A36 / 1018	P/N UTB-200
Stainless Steel 304	P/N UTB-202
Case for SC Block	P/N UTB-203



**Block Type:
IIW Type 1**

Application:

Calibration of transverse and longitudinal wave distance setting determination of the sound beam point of incidence and exact angle of propagation.

Geometry:

1" x 4" x 12". Contains 2" diameter hole and 4" radius. Also 1/8" x 1" radius alternate reflector 1/16" deep on echo side. Per Int'l Institute of Welding (IIW), ASTM-E-164, and MIL-STD-2154

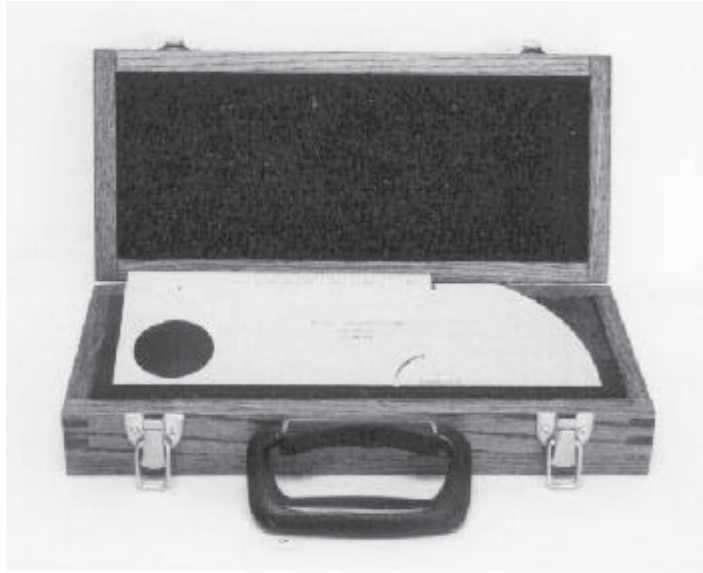

Standard Materials:

Aluminum 7075 T-6	P/N UTB-501
Steel A36 / 1018	P/N UTB-500
Stainless Steel 304	P/N UTB-502
Case for IIW Block Type 1	P/N UTB-503



**Block Type:
IIW Type 2**

Application:

Modified version of IIW Type 1, with a 2" radius 1/4" deep cut out test side, and 3 extra side drilled resolution holes. Per IIW and U.S.A.F.T.O.33B-1-1 (6-1-84)

Standard Materials:

Aluminum 7075 T-6	P/N UTB-511
Steel A36 / 1018	P/N UTB-510
Stainless Steel 304	P/N UTB-512
Case for IIW Block Type 2	P/N UTB-513

Special USAF Block FSN 6635-00-148-5477

Aluminum P/N UTB-514

Special USAF Block FSN 6635-00-415-9225

Steel P/N UTB-519

Block Type:
Mini IIW

Application:
Miniature version of IIW type blocks resembling the Type 2

Geometry:
1"x 2" x 6". Contains 1" diameter hole, 2" radius, 1" radius 1/4" deep cut out test side 3 side drilled resolution holes, and 3/4" sq X .100" deep cut out.

Steel P/N UTB-560
Case for Mini IIW P/N UTB-565

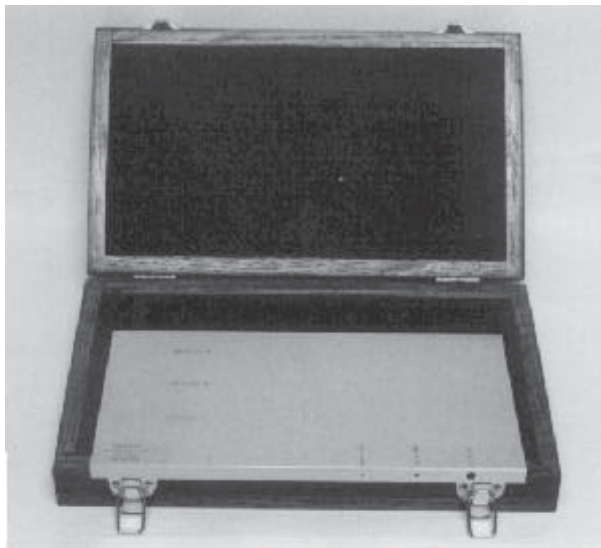

Block Type:
ASME-N-625 Reference Plate

Application:
For longitudinal shear and surface wave sensitivity calibration.

Geometry:
1/2" x 6" x 12". Contains five flat bottom holes and one through hole; three each .062" diameter holes at depths of .050", .250" and through, one .062" diameter hole at 1.5" depth; .125" diameter hole at 1.625 depth; one .250" diameter hole at 1.750" depth. Also contains one .002" deep surface wave notch.

Per ASME Boiler & Pressure Vessel Code Sect. III

Standard Materials:

Aluminum 7075-T6 P/N UTB-001
Steel 1018 P/N UTB-000
Case for ASME N-625 P/N UTB-003

Stainless Steel P/N UTB-002

Block Type:

30 FBH Resolution Block

Application:

Area/ Amplitude plots for normal beam transducer and determining resolution and sensitivity capabilities.

Geometry:

1½" x 4" x 11". Contains three series of 3/64", 5/64", and 8/64" diameter holes at metal travel distances of .050" thru 1.250". Per ASTM-E-428; ASTM-E-127 D/A spec.

Standard Materials:

- | | |
|---------------------|-------------|
| Aluminum 7075T-6 | P/N UTB-405 |
| Steel 4340 | P/N UTB-404 |
| Stainless Steel 304 | P/N UTB-406 |
| Case for 30 FBH | P/N UTB-407 |

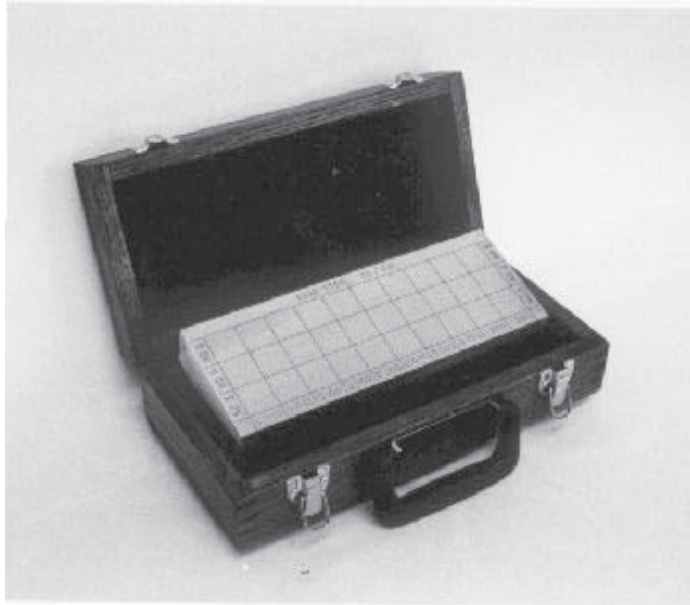

Block Type:

Navships

Application:

Distance correction and sensitivity levels.

Geometry:

1¼" X 3" x 12". Contains seven 3/64" diameter side drilled holes at distances of 1/8 thru 2¾". Per NAVSEA T 9074-AS-GIB-010/271

(Formerly Navships 0900-006-3010sec. 6 & MIL-STD-271F)

Standard Materials:

- | | |
|-------------------------|-------------|
| Aluminum 7075 T-6 | P/N UTB-409 |
| Steel 1018 | P/N UTB-408 |
| Stainless Steel 304 | P/N UTB-410 |
| Case for NAVSHIPS Block | P/N UTB-411 |

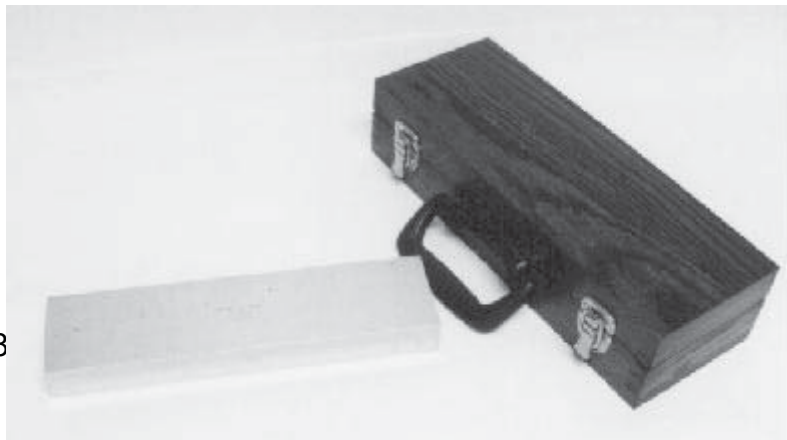

Block Type:
IOW BEAM PROFILE

(English or Metric)

Application:

Beam profile measurement of Angle beam transducer. Per BS 2704

Geometry:

2" x 3" x 12".

Contains two 1/16" diameter x 7/8" deep calibration holes on near side; two 1/16" diameter x 7/8" deep calibration holes on far side. Contains five 1/16" diameter resolution holes drilled on a 10° slope, far side only.

Standard Materials:

Steel P/N UTB-550

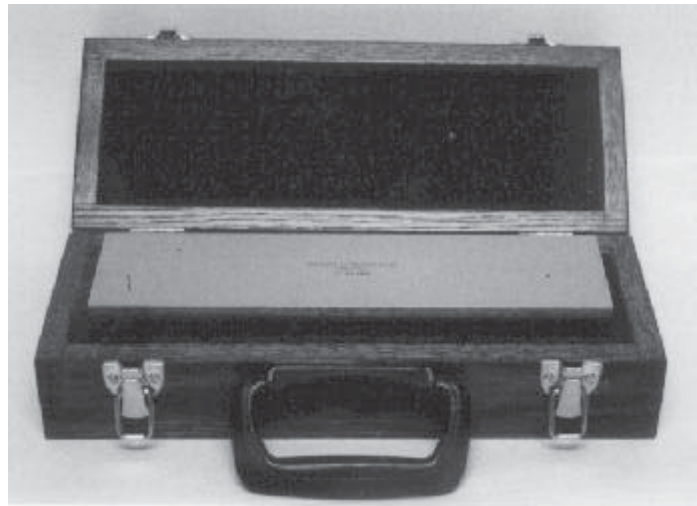

Case for IOW Block P/N UTB-555

Block Type:

Step Blocks

Applications:

Thickness and linearity calibration.

Geometry:

Available in a variety of step size, most common being a four step version with thickness of .250", .500", .750", and 1.00" or a five step version with thickness of .100", .200", .300", .400", and .500". Standard step dimensions are .750" square. Custom step blocks are available. Utility step blocks are fabricated from 1018 steel Per ASTM-E-797

Standard Materials: 4 Step 5 Step

Aluminum 7075-T6 UTB-805 UTB-801

Steel 4340* UTB-804 UTB-800

Stainless UTB-806 UTB-802

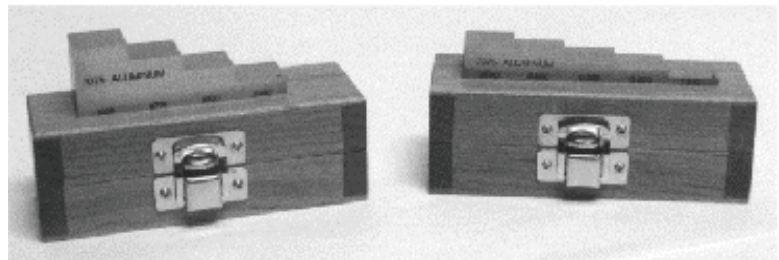

Case for Step Block UTB-807 UTB-803

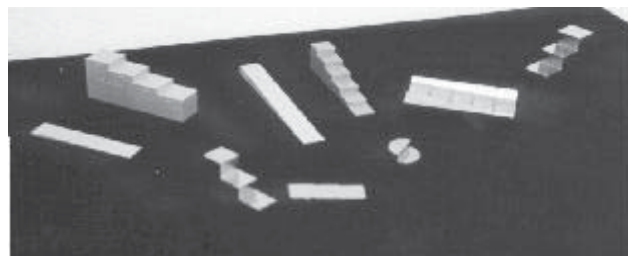

Block Type:

Miniature Resolution Block

Application:

To check resolution capabilities and calibrate high resolution test equipment.

Geometry:

Contains four milled slots 3/16" wide X 5/8" long and six flat bottomed holes; three 3/64" diameter holes and three 1/64" holes:

Standard Materials:

Aluminum 7075 T-6	P/N UTB-315
Steel 1018	P/N UTB-314
Stainless Steel 304	P/N UTB-316
Case for Mini Res Block	P/N UTB-317

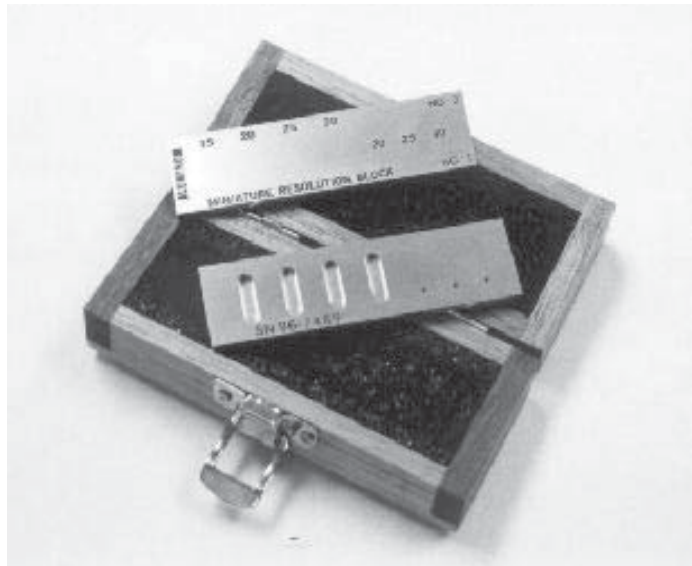

Block Type:

ASME Basic Calibration Block

Application:

Angle beam calibration

Geometry:

Material:	Block Dimensions:
1" or less	.750" X 6" X 7"
Over 1" thru 2"	1.5" X 6" X 10"
Over 2" thru 4"	3" X 6" X 10"

Contains 2 slots; one on each face, and three side drilled holes 1.5" deep X (diameter is determined by the thickness of the block).

Per ASME SEC V Article 23 T-542.1.1

Standard Materials:

Aluminum 7075 T-6	P/N UTB-021
Steel 1018	P/N UTB-020
Stainless Steel 304	P/N UTB-022
Case for ASME Block	P/N UTB-024

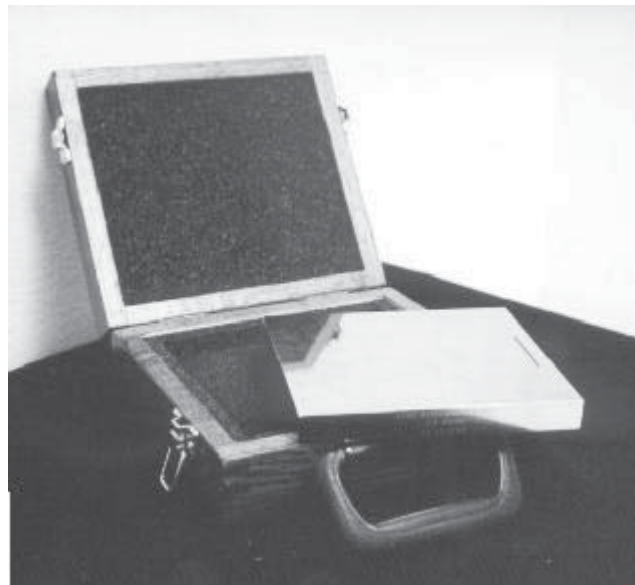



**ASTM
DISTANCE/AMPLITUDE
Set of 19 with Case**

ALUMINUM	P/N UTB-671
STEEL	P/N UTB-670
STAINLESS STEEL	P/N UTB-672

**ASTM
DISTANCE/ AREA AMPLITUDE
Set of 10 with Case**

ALUMINUM	P/N UTB-601
STEEL	P/N UTB-600
STAINLESS STEEL	P/N UTB-602



**ASTM
AREA/ AMPLITUDE
Set of 8 with Case**

ALUMINUM	P/N UTB-701
STEEL	P/N UTB-700
STAINLESS STEEL	P/N UTB-702



ASTM-E-127 or ASTM-E-428

ASTM DISTANCE/AMPLITUDE Set of 19

Contains hole diameters of 3/64", 5/64", or 8/64" with metal travel distances of:

.06" (X-0006)	1.25" (X-0125)
.12" (X-0012)	1.75" (X-0175)
.25" (X-0025)	2.25" (X-0225)
.37" (X-0037)	2.75" (X-0275)
.50" (X-0050)	3.25" (X-0325)
.62" (X-0062)	3.75" (X-0375)
.75" (X-0075)	4.25" (X-0425)
.87" (X-0087)	4.75" (X-0475)
1.0" (X-0100)	5.25" (X-0525)
	5.75" (X-0575)

ASTM DISTANCE/AREA AMPLITUDE Set of 10

Contains the following hole diameters and metal travel distances:

3/64" - 3.0" (3-0300)
5/64" - .12" (5-0012)
5/64" - .25" (5-0025)
5/64" - .50" (5-0050)
5/64" - .75" (5-0075)
5/64" - 1.5" (5-0150)
5/64" - 3.0" (5-0300)
5/64" - 6.0" (5-0600)
8/64" - 3.0" (8-0300)
8/64" - 6.0" (8-0600)

ASTM AREA / AMPLITUDE Set of 8

Contains the following hole diameters and metal travel distances:

1/64" - 3.0" (1-0300)
2/64" - 3.0" (2-0300)
3/64" - 3.0" (3-0300)
4/64" - 3.0" (4-0300)
5/64" - 3.0" (5-0300)
6/64" - 3.0" (6-0300)
7/64" - 3.0" (7-0300)
8/64" - 3.0" (8-0300)

Standard Materials:

[Aluminum 7075 T-6 Individual Blocks](#)
[Steel 4340 Vac. Melt Individual Blocks](#)
[Stainless Steel 304 Individual Blocks](#)

EDDY – CURRENT BLOCKS

Detek, Inc provides a wide variety of Eddy Current standards in addition to the standard block shown here.

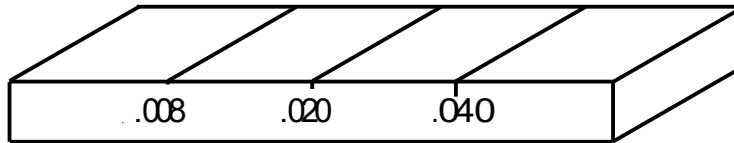

Block Type:

Eddy-Current Standard

Block dimensions:

.312" thick X 1.375" wide X 3.156" long

Contains three slots; .008", .020", and .040" deep

Standard Materials:

Steel 4340

P/N ESA-FETB1

Aluminum 7075 T-6

P/N ESA-ALTB1

Titanium 6Al-4V

P/N ESA-TITB1

Stainless Steel 304

P/N ESA-SSTB1

Magnesium AZ-31

P/N ESA-MGTB1



DETEK NONDESTRUCTIVE TESTING EQUIPMENT

FLAWTECH STANDARD KITS

**RT KIT
UT KIT
MT/PT KIT
VT KIT**

EACH KIT CONTAINS

- 20 "REAL" FLAWS PER KIT
- 10 LARGE 4" X 8" CARBON STEEL SPECIMENS PER KIT
- "FREE" CARRYING CASE
- DETAILED DOCUMENT PACKAGE WITH CAD DRAWINGS

DEMONSTRATION KIT

- 5 SPECIMENS & 11 FLAWS

REFERENCE RADIOGRAPHS

- FILM ONLY - 16 RADIOGRAPHS SHOWING 20 REAL FLAWS
- CUSTOM KITS AVAILABLE ●

**SPECIAL
KITS**

FLAWTECH STANDARD KIT SPECIMENS ARE DESIGNED TO:

- ENHANCE THE TRAINING & QUALIFICATION OF LEVEL I & II PERSONNEL WITH REGARDS TO SNT-TC-1A, EN473 & PCN.
- ASSIST WITH BASIC FLAW DETECTION, SIZING AND INTERPRETATION USING COMMON WELD GEOMETRIES AND FLAW TYPES.



**6805 COOLRIDGE DR ■ TEMPLE HILLS MD 20748
301-449-7300 ■ 800-638-0554 ■ FAX 301-449-7011**

EMAIL: sales@detek.com



NONDESTRUCTIVE TESTING EQUIPMENT

#	FLAW TYPE	WELD	NDT METHOD
---	-----------	------	------------

10	TOE CRACK	SV / DV	-	MT/PT	UT	RT
11	TOE CRACK	FILLET	-	MT/PT	UT	-
12	ROOT CRACK	SV	-	MT/PT	UT	RT
13	UNDERBEAD CRACK	FILLET	-	-	UT	-
14	CENTER LINE CRACK (SURFACE)	SV / DV	-	MT/PT	UT	RT
15	CENTER LINE CRACK (SUB-SURFACE)	SV / DV	-	-	UT	RT
16	CIRCUMFERENTIAL CRACK (FLUSH CROWN)	SV / DV	-	MT/PT	UT	RT
17	TRANSVERSE CRACK (FLUSH CROWN)	SV / DV	-	MT/PT	UT	-
18	BASE METAL CRACK (CROWN HAZ AREA)	SV / DV	-	MT/PT	UT	-
19	BASE METAL CRACK (ROOT HAZ AREA)	SV	-	MT/PT	UT	-
20	CRATER CRACK (CROWN STOP/START AREA)	SV / DV	VT	MT/PT	-	-
30	POROSITY (SUB-SURFACE)	SV / DV	-	-	UT	RT
31	POROSITY (SUB-SURFACE)	FILLET	-	-	UT	RT
32	POROSITY (SURFACE)	SV / DV	VT	MT/PT	-	-
33	POROSITY (SURFACE)	FILLET	VT	MT/PT	-	-
34	SINGLE GAS PORE	SV / DV	-	-	UT	RT
35	SINGLE GAS PORE	FILLET	-	-	-	RT
36	SLAG INCLUSION (ROOT AREA)	SV	-	-	UT	RT
37	SLAG INCLUSION (WELD GROOVE AREA)	SV / DV	-	-	UT	RT
38	SLAG INCLUSION (ROOT AREA)	FILLET	-	-	UT	RT
39	TUNGSTEN INCLUSION (ROOT AREA)	SV / DV	-	-	-	RT
50	LAMINATION (BASE METAL)	SV	-	-	UT	-
51	LAMINATION (BASE METAL)	WP FACE	-	MT/PT	-	-
52	LACK OF FUSION (SUB-SURFACE)	SV / DV	-	-	UT	-
53	LACK OF FUSION (SURFACE BREAKING)	SV / DV	-	MT/PT	UT	-
54	LACK OF FUSION (SURFACE BREAKING)	FILLET	-	MT/PT	-	-
55	LACK OF FUSION (ROOT AREA)	SV	-	MT/PT	UT	-
56	INCOMPLETE ROOT PENETRATION	SV	VT	MT/PT	UT	RT
57	INCOMPLETE ROOT PENETRATION	DV	-	-	UT	RT
58	INCOMPLETE ROOT PENETRATION (BRIDGING)	FILLET	-	-	UT	-
59	INCOMPLETE GROOVE WELD (CROWN AREA)	SV / DV	VT	MT/PT	UT	RT
70	ROOT CONCAVITY	SV	VT	-	-	RT
71	EXCESS ROOT PENETRATION	SV	VT	-	-	RT
72	MISALIGNMENT (ROOT & CROWN AREA)	SV	VT	-	-	RT
73	UNEVEN LEG LENGTH	FILLET	VT	-	-	-
74	EXCESS CROWN	SV / DV	VT	-	-	-
75	EXCESS CROWN	FILLET	VT	-	-	-
76	CONCAVE CROWN	SV / DV	VT	-	-	-
77	CONCAVE CROWN	FILLET	VT	-	-	-
78	UNDERCUT	SV / DV	VT	-	-	-
79	UNDERCUT	FILLET	VT	-	-	-
80	OVERLAP	FILLET	VT	MT/PT	-	-
90	WELD SPATTER	SV / DV	VT	-	VT	RT
91	WELD SPATTER	FILLET	VT	-	VT	RT
92	CHIPPING HAMMER MARKS	SV / DV	VT	-	VT	RT
93	CHIPPING HAMMER MARKS	FILLET	VT	-	VT	-

HOW TO REQUEST A CUSTOM SPECIMEN

1ST	2ND	3RD
SELECT A TOLERANCE	SELECT YOUR FLAWS	SELECT THE MATERIAL
STANDARD +/-0.150" (4MM)	FROM THE ABOVE TABLE	TYPE, WELD PREP GEOMETRY
ADVANCED +/-0.080" (2MM)	OR SPECIFY YOUR	AND THE REQUIRED NDT
CRITICAL +/-0.040" (1MM)	SPECIAL REQUIREMENTS	METHOD OF INSPECTION