

DSCT47



Linearized Thermocouple Input Transmitters

Description

Each DSCT47 thermocouple input transmitter provides a single channel of thermocouple input which is filtered, isolated, amplified, linearized, and converted to a process current output (Figure 1). Signal filtering is accomplished with a five-pole filter, which provides 85dB of normal-mode-rejection at 60Hz and 80dB at 50Hz. An anti-aliasing pole is located on the field side of the isolation barrier, and the other four are on the process loop side. After the initial field-side filtering, the input signal is chopped by a proprietary chopper circuit. Isolation is provided by transformer coupling, again using a proprietary technique to suppress transmission of common mode spikes or surges.

Linearization is achieved by creating a non-linear transfer function through the module itself. This non-linear transfer function is configured at the factory and is designed to be equal and opposite to the thermocouple non-linearity.

The DSCT47 can interface to eight industry standard thermocouple types: J, K, T, E, R, S, B and N. Each transmitter is cold-junction compensated to correct for parasitic thermocouples formed by the thermocouple wire and screw terminals on the transmitter. Upscale open thermocouple detection is provided by circuitry. Downscale indication can be implemented by installing a 47MΩ, ±20% resistor between screw terminals 6 (+IN) and 8 (-EXC) on the input terminal block.

Special input and output circuits on the DSCT47 transmitters provide protection against accidental connection of power-line voltages up to 240VAC and against transient events as defined by ANSI/IEEE C37.90.1. Loop power lines are secured to the module using screw terminals, which are in pluggable terminal blocks for ease of system assembly and reconfiguration. Transmitter zero and

► Features

- Interfaces to Types J, K, T, E, R, S, B, and N Thermocouples
- Linearizes Thermocouple Signal
- Process Current Output
- 1500Vrms Transformer Isolation
- ANSI/IEEE C37.90.1 Transient Protection
- Input and Output Protected to 240VAC Continuous
- Up to 60V Loop Voltage
- 160dB CMR
- 85dB NMR at 60Hz, 80dB at 50Hz
- ±0.10% Accuracy
- Easily Mounts on Standard DIN Rail
- CSA and FM Approvals Pending
- CE Compliant

span settings are adjustable up to ±3%. The adjustments are made using potentiometers located under the front panel label and are non-interactive for ease of use.

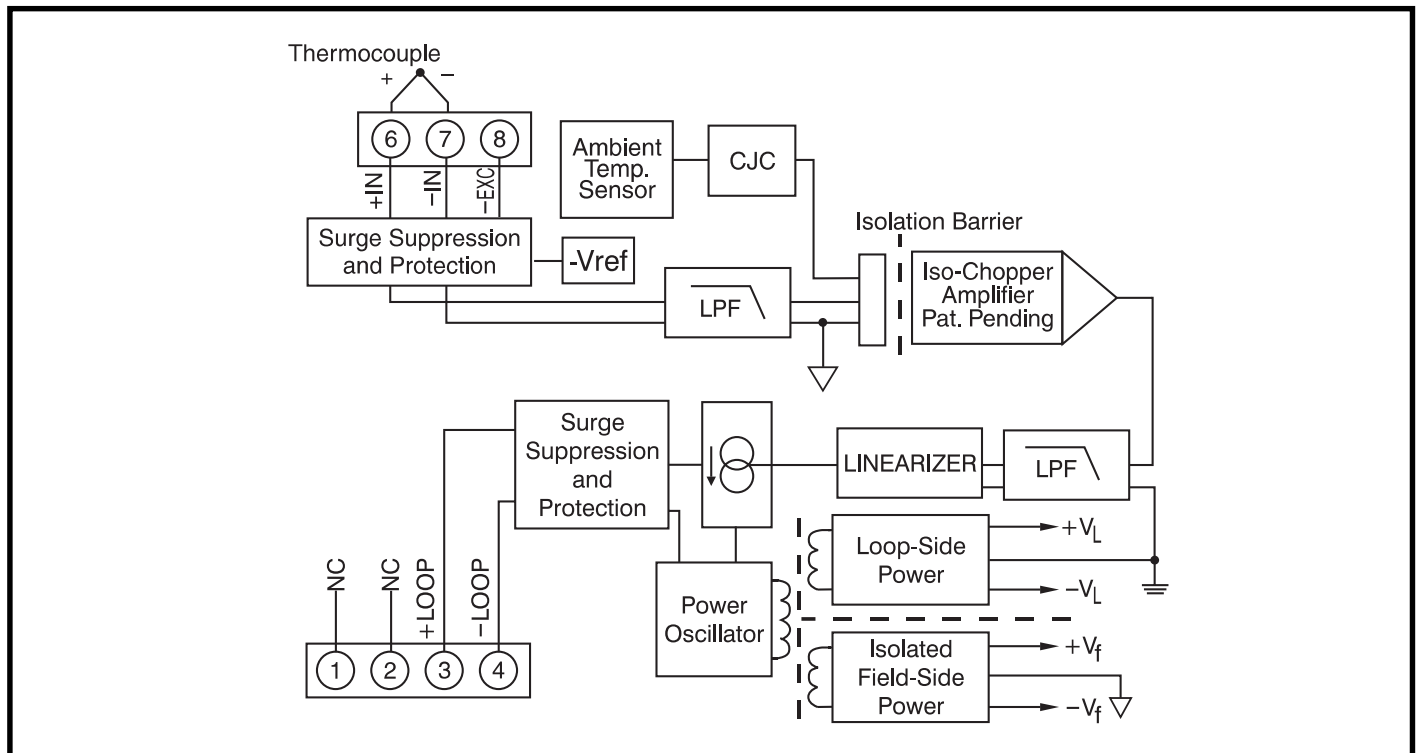

Figure 1: DSCT47 Block Diagram

Specifications Typical at $T_A = +25^\circ\text{C}$ and +24V loop voltage

Module	DSCT47
Input Range	Standard thermocouple temperature limits as per NIST monograph 175, ITS-90
Input Bias Current	-25nA
Input Resistance	
Normal	50M Ω
Power Off	66k Ω
Overload	66k Ω
Input Protection	
Continuous	240Vrms max
Transient	ANSI/IEEE C37.90.1
CMV, Input to Output	
Continuous	1500Vrms max
Transient	ANSI/IEEE C37.90.1
CMR (50Hz or 60Hz)	160dB
NMR	85dB at 60Hz, 80dB at 50Hz
Adjustability	$\pm 3\%$ Zero and Span
Accuracy	See Ordering Information
Stability	
Offset	$\pm 60\text{ppm}/^\circ\text{C}$
Gain	$\pm 80\text{ppm}/^\circ\text{C}$
Cold Junction Compensation	
Accuracy, $+25^\circ\text{C}$	$\pm 0.25^\circ\text{C}$
Accuracy, 0°C to $+50^\circ\text{C}$	$\pm 0.50^\circ\text{C}$
Accuracy, -40°C to $+80^\circ\text{C}$	$\pm 1.25^\circ\text{C}$
Open Input Response	Upscale
Open Input Detection Time	< 5s
Noise	
Output, 100kHz	3 μArms
Bandwidth, -3dB	3Hz
Response Time, 90% Span	165ms
Output Range	4mA to 20mA
Output Limits	
Under-range	2.8mA
Over-range	29mA
Output Protection	
Reverse Polarity	Continuous
Over-voltage	240Vrms Continuous
Transient	ANSI/IEEE C37.90.1
Loop Supply Voltage	10.8V to 60V
Loop Supply Sensitivity	$\pm 0.0005\%/V$
Turn-On Delay	400ms
Environmental	
Operating Temp. Range	-40°C to $+80^\circ\text{C}$
Storage Temp. Range	-40°C to $+80^\circ\text{C}$
Relative Humidity	0 to 95% Noncondensing
Emissions	EN50081-1, ISM Group 1, Class A (Radiated, Conducted)
Immunity	EN50082-1, ISM Group 1, Class A (ESD, RF, EFT)
Mechanical Dimensions	2.95" x 0.89" x 4.13"
(h)(w)(d)	(75mm x 22.5mm x 105mm)
Mounting	DIN EN 50022 -35x7.5 or -35x15 rail

Ordering Information

Model	TC Type [†]	Input Range	Accuracy ⁽¹⁾	
DSCT47J-01	J	0°C to $+760^\circ\text{C}$ ($+32^\circ\text{F}$ to $+1400^\circ\text{F}$)	$\pm 0.1\%$ span	$\pm 0.76^\circ\text{C}$
DSCT47J-02	J	-100°C to $+300^\circ\text{C}$ (-148°F to $+572^\circ\text{F}$)	$\pm 0.1\%$ span	$\pm 0.40^\circ\text{C}$
DSCT47J-03	J	0°C to $+500^\circ\text{C}$ ($+32^\circ\text{F}$ to $+932^\circ\text{F}$)	$\pm 0.1\%$ span	$\pm 0.50^\circ\text{C}$
DSCT47K-04	K	0°C to $+1000^\circ\text{C}$ ($+32^\circ\text{F}$ to $+1832^\circ\text{F}$)	$\pm 0.1\%$ span	$\pm 1.00^\circ\text{C}$
DSCT47K-05	K	0°C to $+500^\circ\text{C}$ ($+32^\circ\text{F}$ to $+932^\circ\text{F}$)	$\pm 0.1\%$ span	$\pm 0.50^\circ\text{C}$
DSCT47K-13	K	-100°C to $+1350^\circ\text{C}$ (-148°F to $+2462^\circ\text{F}$)	$\pm 0.1\%$ span	$\pm 1.45^\circ\text{C}$
DSCT47K-14	K	0°C to $+1200^\circ\text{C}$ (32°F to $+2192^\circ\text{F}$)	$\pm 0.1\%$ span	$\pm 1.20^\circ\text{C}$
DSCT47T-06	T	-100°C to $+400^\circ\text{C}$ (-148°F to $+752^\circ\text{F}$)	$\pm 0.1\%$ span	$\pm 0.50^\circ\text{C}$
DSCT47T-07	T	0°C to $+200^\circ\text{C}$ ($+32^\circ\text{F}$ to $+392^\circ\text{F}$)	$\pm 0.1\%$ span	$\pm 0.20^\circ\text{C}$
DSCT47E-08	E	0°C to $+1000^\circ\text{C}$ ($+32^\circ\text{F}$ to $+1832^\circ\text{F}$)	$\pm 0.1\%$ span	$\pm 1.00^\circ\text{C}$
DSCT47R-09	R	$+500^\circ\text{C}$ to $+1750^\circ\text{C}$ ($+932^\circ\text{F}$ to $+3182^\circ\text{F}$)	$\pm 0.1\%$ span	$\pm 1.25^\circ\text{C}$
DSCT47S-10	S	$+500^\circ\text{C}$ to $+1750^\circ\text{C}$ ($+932^\circ\text{F}$ to $+3182^\circ\text{F}$)	$\pm 0.1\%$ span	$\pm 1.25^\circ\text{C}$
DSCT47B-11	B	$+500^\circ\text{C}$ to $+1800^\circ\text{C}$ ($+932^\circ\text{F}$ to $+3272^\circ\text{F}$)	$\pm 0.1\%$ span	$\pm 1.30^\circ\text{C}$
DSCT47N-15	N	-100°C to $+1300^\circ\text{C}$ (-148°F to $+2372^\circ\text{F}$)	$\pm 0.1\%$ span	$\pm 1.40^\circ\text{C}$

†Thermocouple Alloy Combinations

Standards: DIN IEC 584, ANSI MC96-1-82, JIS C 1602-1981

Type	Material
J	Iron vs. Copper-Nickel
K	Nickel-Chromium vs. Nickel-Aluminum
T	Copper vs. Copper-Nickel
E	Nickel-Chromium vs. Copper-Nickel
R	Platinum-13% Rhodium vs. Platinum
S	Platinum-10% Rhodium vs. Platinum
B	Platinum-30% Rhodium vs. Platinum-6% Rhodium
N	Nickel-14.2% Chromium-1.4% Silicon vs. Nickel-4.4% Silicon- 0.1% Magnesium

NOTES:

(1) Includes conformity, hysteresis, repeatability and CJC error.