

CHAPTER 10

Advanced Welding Symbols

LEARNING OBJECTIVE

- Be able to interpret AWS welding symbols that include all of the information that could be used on them

KEY TERMS

Weld all around	Pitch	Spacer
Field weld	Chain intermittent weld	Convex contour
Weld length	Staggered intermittent weld	Concave contour
Intermittent weld	Consumable insert	Flush contour
Skip weld	Backing	Melt-through

OVERVIEW

Many additional elements can be added to the basic parts of the AWS welding symbol. The additional elements and their placement, along with the basic parts of the welding symbol, are shown in Figures 10-1 and 10-2. They are described throughout the remainder of this chapter.

WELD ALL AROUND

The specification to **weld all around** requires that the weld be made to encapsulate the entire joint. In the case of a circular joint, the weld all around symbol is not required. The weld all around symbol consists of a circle that is placed over the intersection where the end of the reference line meets the arrow. Examples of weld all around welds and welding symbols are shown in Figures 10-3 and 10-4.

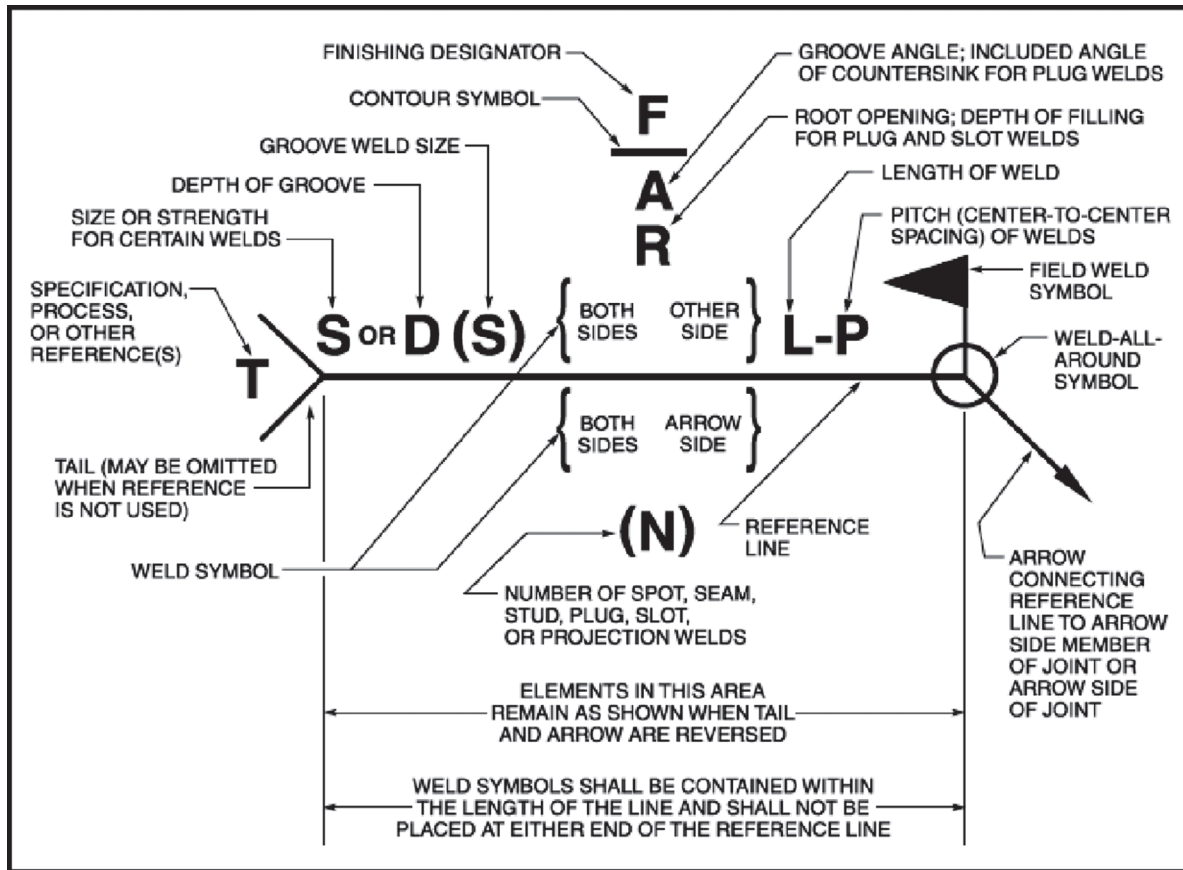

Figure 10-1 AWS Standard Locations of the Elements of a Welding Symbol (AWS A2.4:2012, Figure 3 reproduced and adapted with permission from the American Welding Society (AWS), Miami, FL.)

WELD-ALL-AROUND	FIELD WELD	MELT-THROUGH	CONSUMABLE INSERT (SQUARE)	BACKING (RECTANGLE)	SPACER (RECTANGLE)	CONTOUR		
						FLUSH OR FLAT	CONVEX	CONCAVE

Figure 10-2 AWS Supplementary Symbols (AWS A2.4:2012, Figure 2 reproduced and adapted with permission from the American Welding Society (AWS), Miami, FL.)

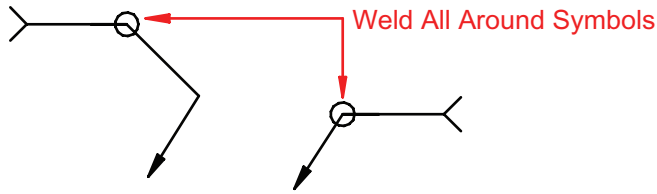

Figure 10-3 Weld All Around Symbols

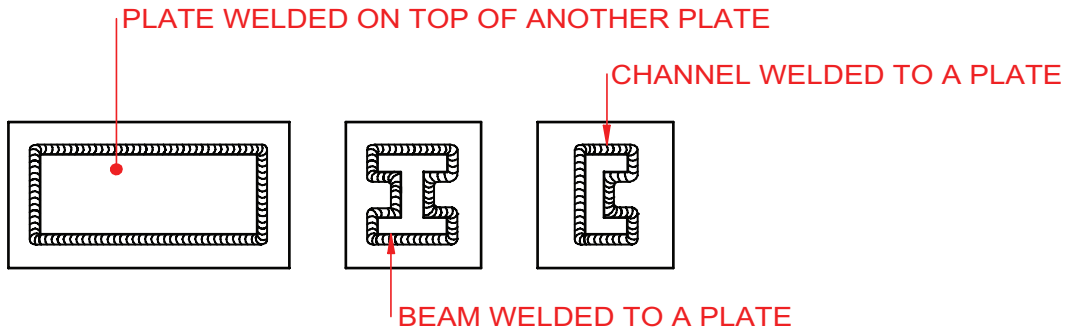

Figure 10-4 Example of Weld All Around Welds

FIELD WELD

A **field weld** is defined by the American Welding Society (AWS) as “[a] weld made at a location other than a shop or the place of initial construction.”¹ The field weld symbol consists of a flag that is placed at the intersection where the end of the reference line meets the arrow (see Figure 10-5).

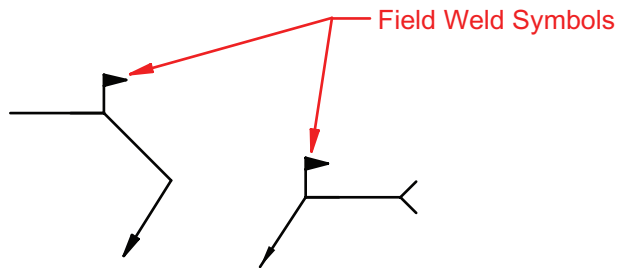

Figure 10-5 Field Weld Symbol Examples

¹ AWS A3.0M/A3.0:2010, reproduced with permission from the American Welding Society (AWS), Miami, FL

WELD LENGTH

Each weld, with the exception of spot and plug welds, has a length component. The **weld length** may be the entire length of the joint or some portion thereof. There are several different methods for providing the weld length information on a drawing. When the weld is to be the entire length of the joint, the length component is not required on the welding symbol. The welding symbol points to the joint requiring the weld, and the weld is made the entire length of that particular joint, as shown in Figure 10-6. If a weld is required to make a change in direction, an additional welding symbol or a multi-arrow symbol should be used.

When the weld length is not required to extend the complete length of the joint, it can be defined by placing the required length to the right of the weld symbol. The welding symbol then points to the area of the joint requiring the weld. It may replace the standard length dimension, as shown in Figure 10-7.

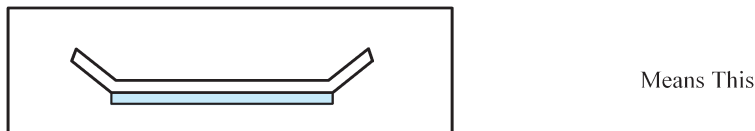
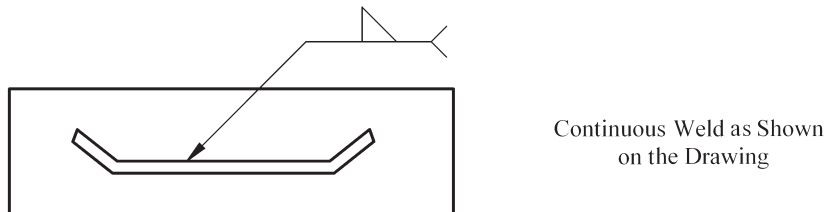
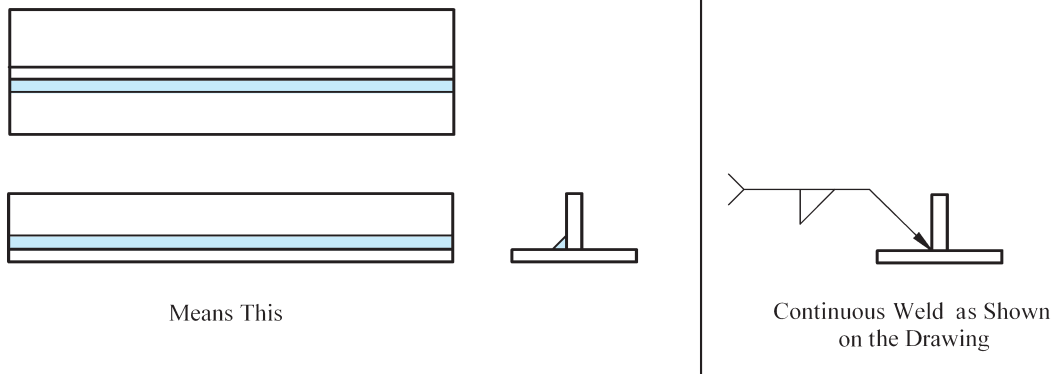

Figure 10-6 Examples of Continuous Welds

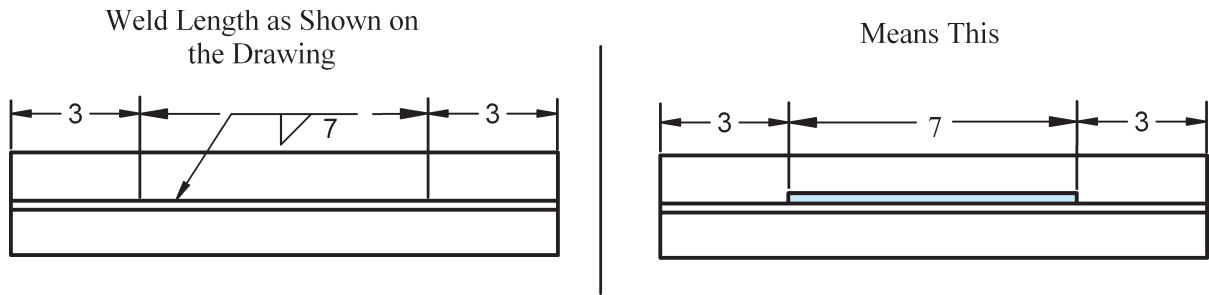

Figure 10-7 Weld Length Specified on Welding Symbol Between Extension Lines

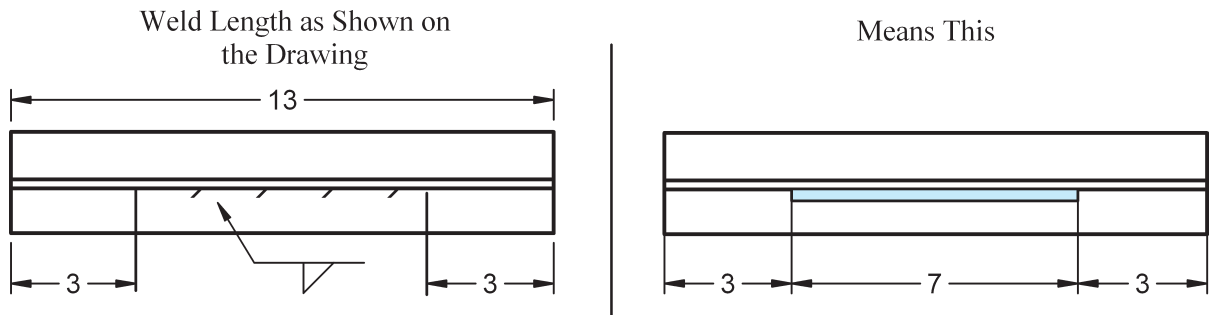

Figure 10-8 Weld Length Specified on Welding Symbol Between Extension Lines with Section Lines Representing the Weld Area

Placing section lines in the area where the weld is to be placed can also be used in combination with standard dimensions and welding symbols to identify the required weld length and weld location. See Figure 10-8.

INTERMITTENT WELDS

An **intermittent weld**, also called a **skip weld**, consists of a series of welds placed on a joint, with unwelded spaces between each of the welds. The individual weld segments in an intermittent weld have a length and **pitch** component. The weld length is the linear distance of each weld segment. The length is shown in the welding symbol to the right of the weld symbol. The pitch is the center-to-center distance of each of the weld segments. It is shown to the right of the length on the welding symbol, with a dash between the two. This concept is shown in Figure 10-9.

When intermittent welds are placed on both sides of a joint, they can be either directly opposite each other, known as a **chain intermittent weld**, or they can be offset, known as a **staggered intermittent weld**. The chain intermittent weld is shown in Figure 10-10. The staggered intermittent weld is shown in Figure 10-11.

Intermittent Fillet Weld as Shown on the Drawing

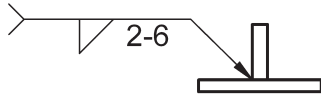

Means This

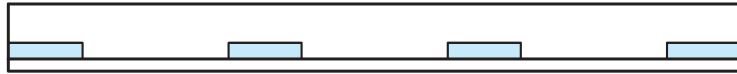
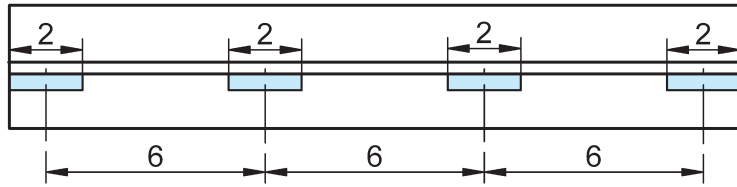
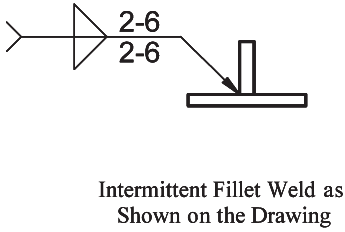
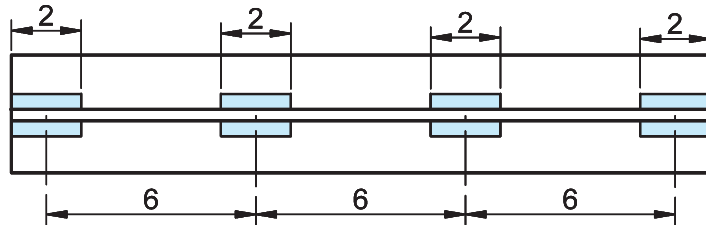

Figure 10-9 Intermittent Weld



Intermittent Fillet Weld as Shown on the Drawing



Means This

Figure 10-10 Chain Intermittent Weld

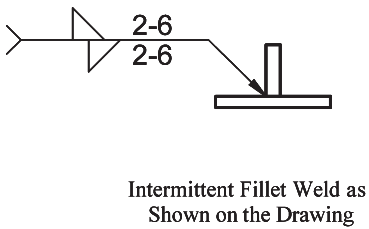

Intermittent Fillet Weld as Shown on the Drawing

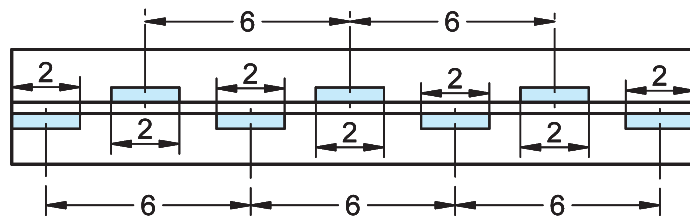

Means This (Top or Plan View)

Figure 10-11 Staggered Intermittent Weld

WELD CONTOUR SYMBOLS

The contour of a weld refers to the shape of its face. A weld with a **convex contour** has a face that protrudes out in a convex shape from its toes; a weld with a **concave contour** has a face that is concave (sinks in from its toes); and a weld with a **flush contour** has a face that is flush with the base metal, or is flat from one toe to the other. When required, the contour symbol is added to a welding symbol so that it is oriented to mimic the required contour of the weld (see Figure 10-12). When a contour symbol is not added to the welding symbol, standard welding and shop practices should be followed.

FINISH SYMBOLS

Placing a finish symbol adjacent to the contour symbol specifies the method of making the contour. The finish symbols are made up of letters. The letters and their corresponding methods are listed below.

- U = unspecified** → This means that any appropriate method may be used.
- G = grinding**
- M = machining**
- C = chipping**

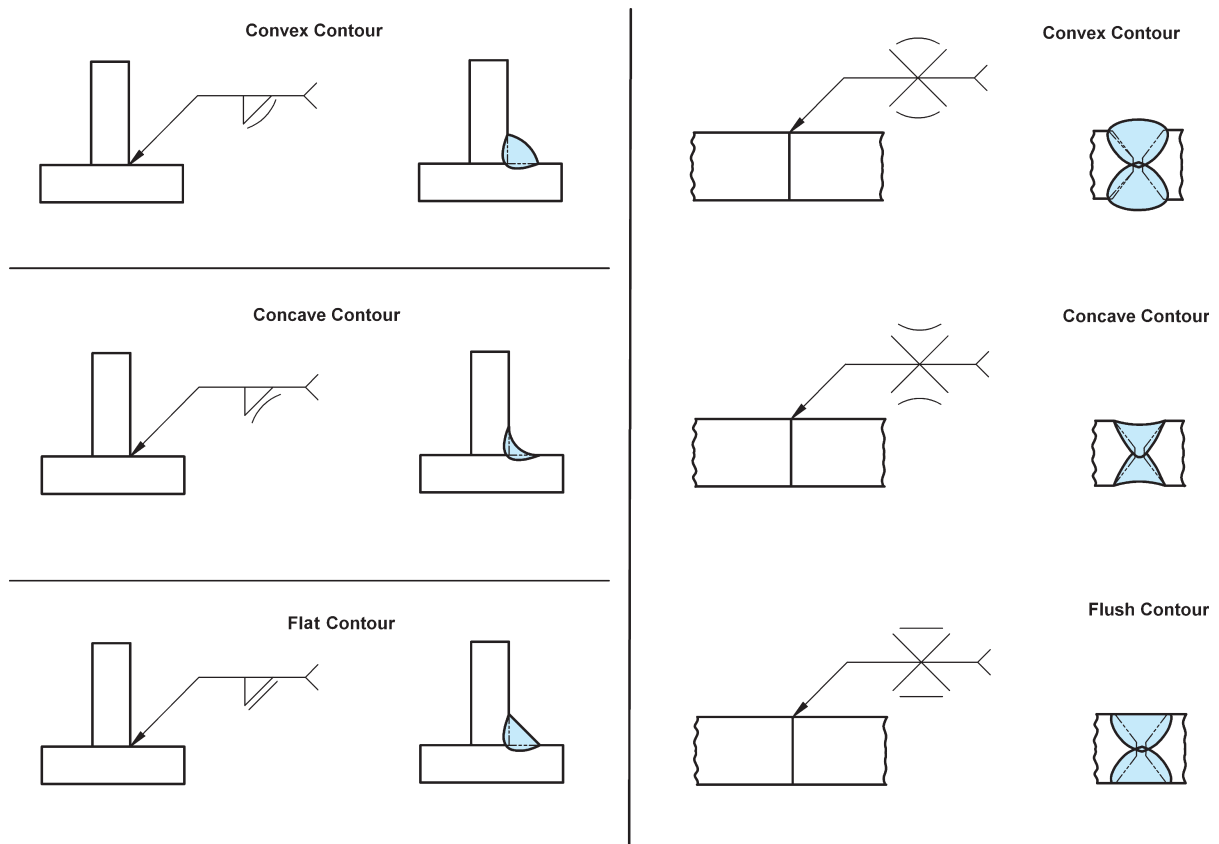

Figure 10-12 Contour Symbols

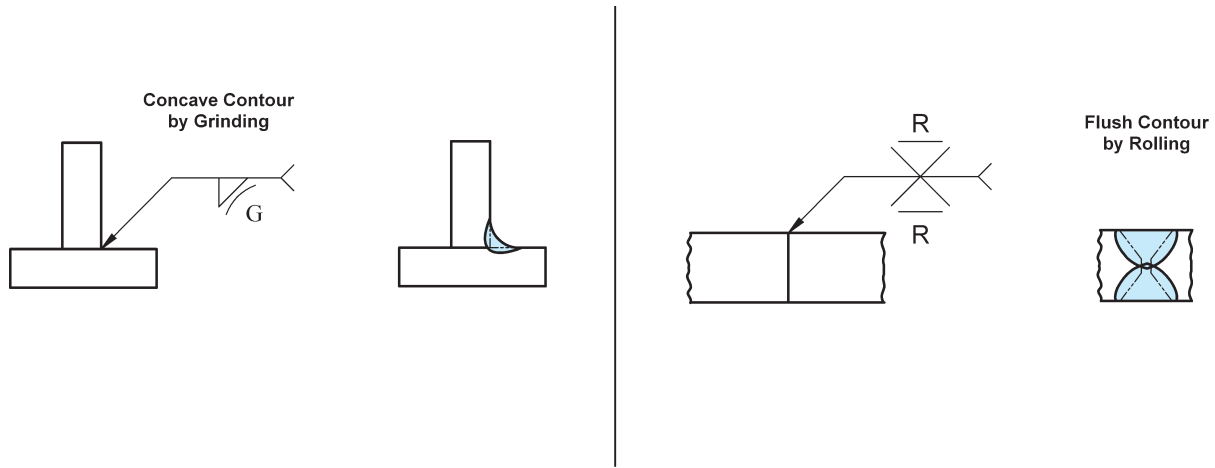

Figure 10-13 Examples of Contour Symbols with Method of Finish

R =rolling
H =hammering
P =planishing

See Figure 10-13 for an example of a finish Symbol.

FILLET WELDS

A welding symbol for a fillet weld includes the required fillet weld symbol and (as needed) the size, length, pitch, contour, method of making the contour, weld all around, field weld, and any other supplemental information listed in the tail of the welding symbol. See Figure 10-14.

The size of the fillet weld is shown to the left of the weld symbol. It represents the length of the legs of the largest right triangle that can fit within the weld at it's smallest point, with the vertex of the triangle located at the intersection of the two members being joined. See Figure 10-15.

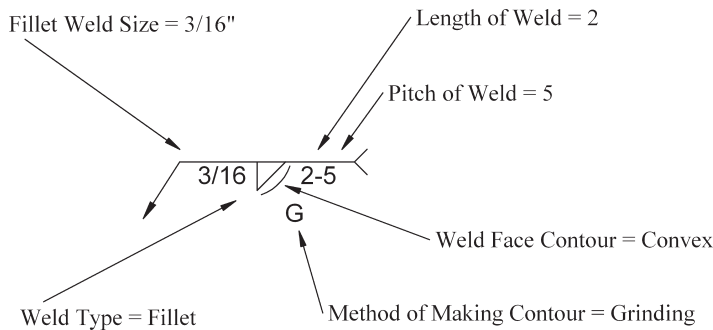

Figure 10-14 Example of a Welding Symbol for a Fillet Weld

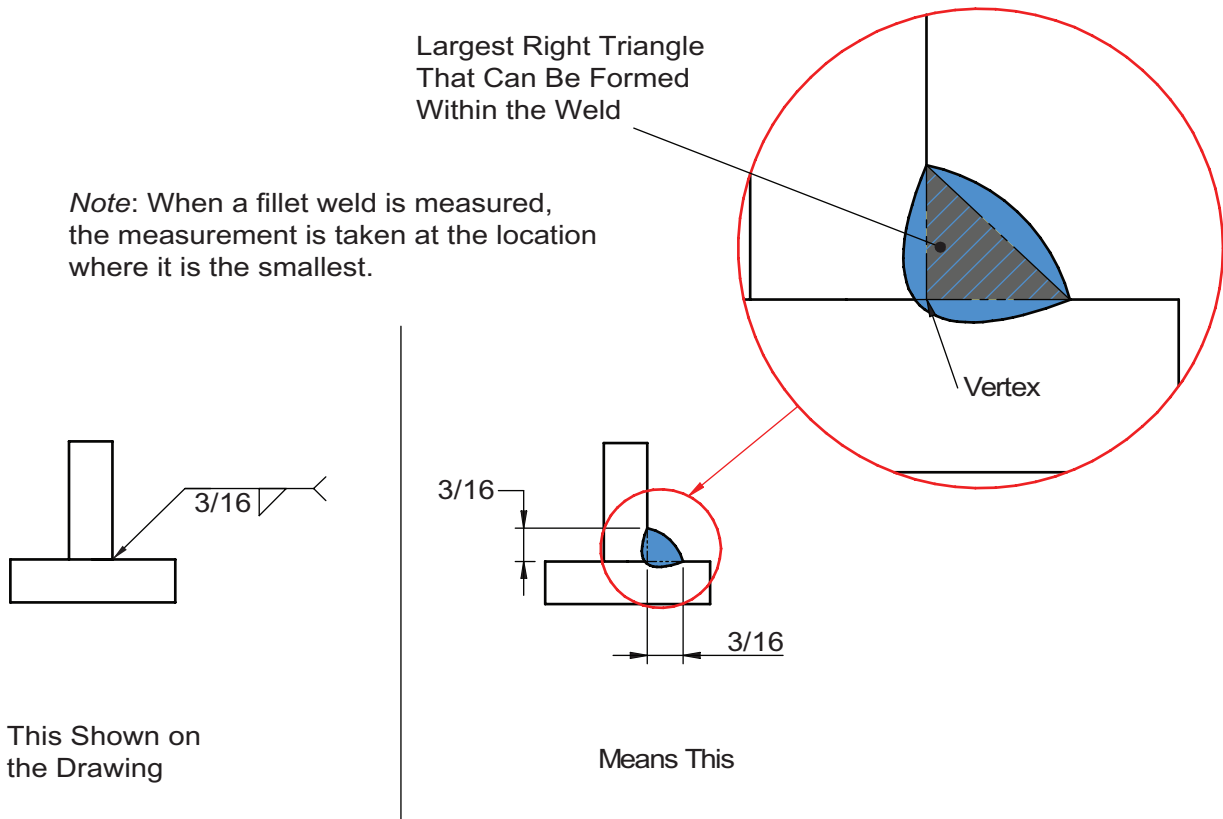

Figure 10-15 Fillet Weld Size

UNEQUAL LEG FILLET WELDS

A fillet weld can be required to have unequal legs. In such cases, the size for each of the legs is shown on the welding symbol to the left of the weld symbol and is written in parentheses. The only way to know which leg goes with which size is through either a detail drawing that shows the weld joint, as in Figure 10-16; a note; or other revealing information, such as one of the legs is required to be longer than one of the sides, as in Figure 10-17.

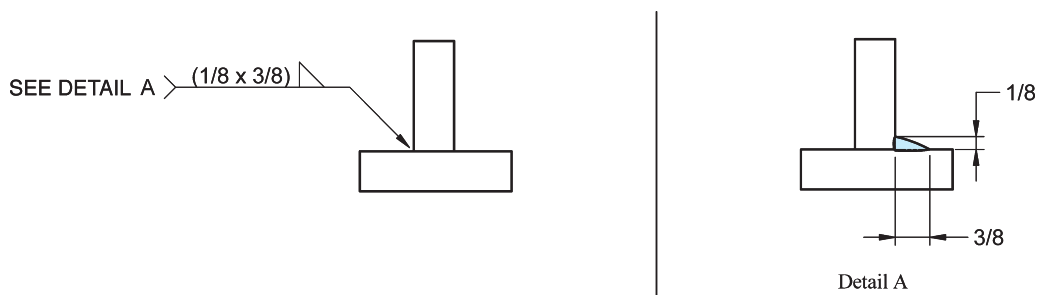

Figure 10-16 Unequal Leg Fillet with Detail Drawing

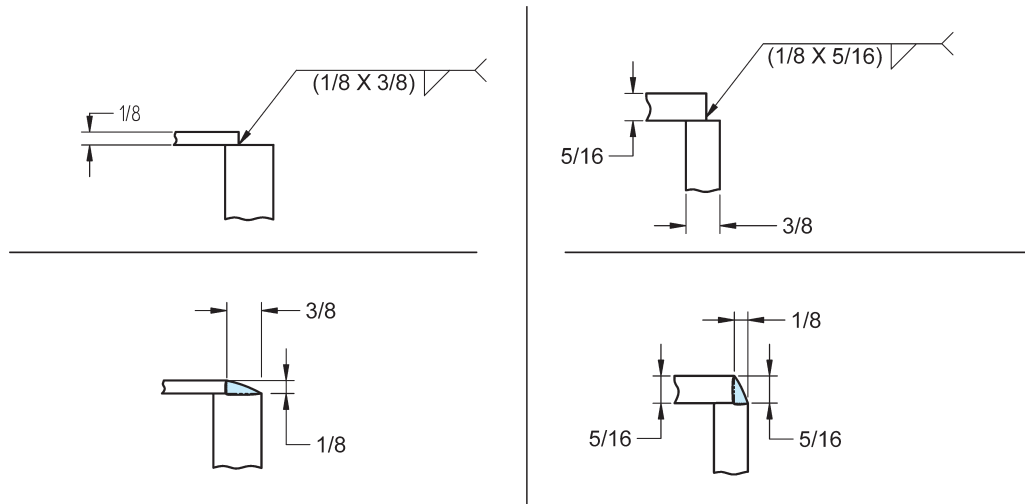

Figure 10-17 Unequal Leg Fillets That Could Be Shown Without Detail

GROOVE WELDS

The welding symbol for a groove weld may include, as needed, the groove weld symbol, size, depth of preparation, root opening, groove angle (also called included angle) contour, method of making the contour, length, pitch, weld all around, field weld, and any other supplemental information listed in the tail of the welding symbol. See Figures 10-18 and 10-19. When the type of joint preparation (joint geometry) is optional, the weld symbol may be omitted. In such cases, an empty reference line with the letters CJP in the tail indicate a complete joint penetration weld. In other cases of optional joint geometry, the weld size shown in parenthesis, may be the only item on the reference line.

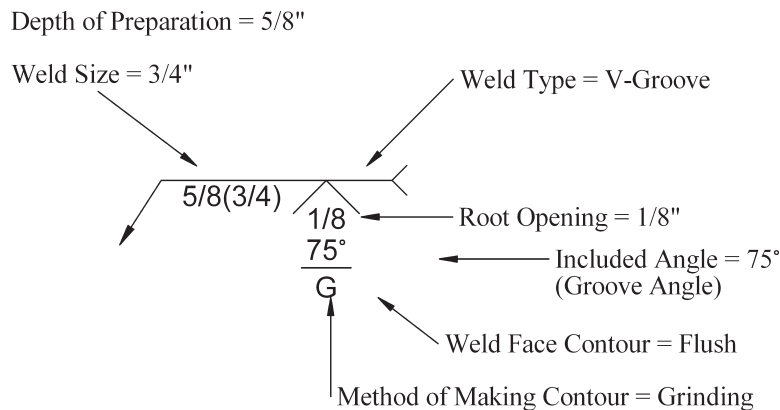
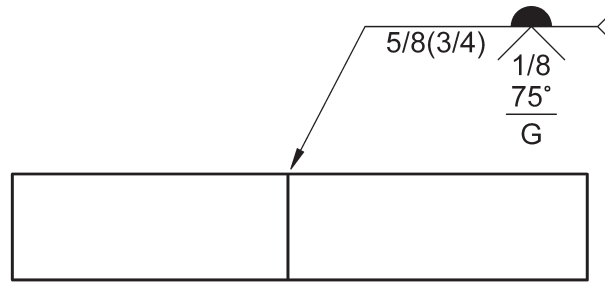
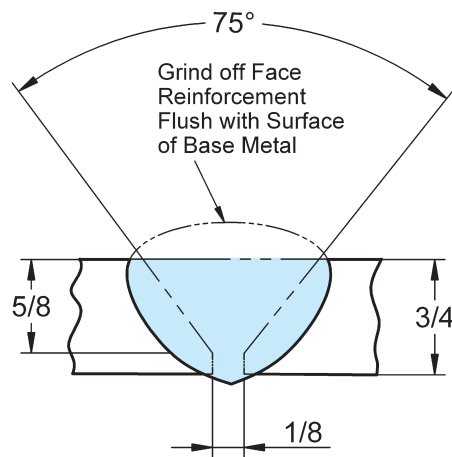

Figure 10-18 Welding Symbol Example for a Groove Weld



This Shown on
the Drawing



Means This

Figure 10-19 Example of a Groove Weld

MELT-THROUGH

Melt-through is defined by the American Welding Society (AWS) as “visible root reinforcement produced in a joint welded from one side.”² In other words, melt-through is the penetrated weld metal that extends beyond the base metal on the backside of a joint welded from the opposite side. Height, contour, method of contour, and tail specifications are all supplemental types of information that can be added to the melt-through weld symbol. See Figures 10-20 and 10-21.

² AWS A3.0M/A3.0:2010, reproduced with permission from the American Welding Society (AWS), Miami, FL

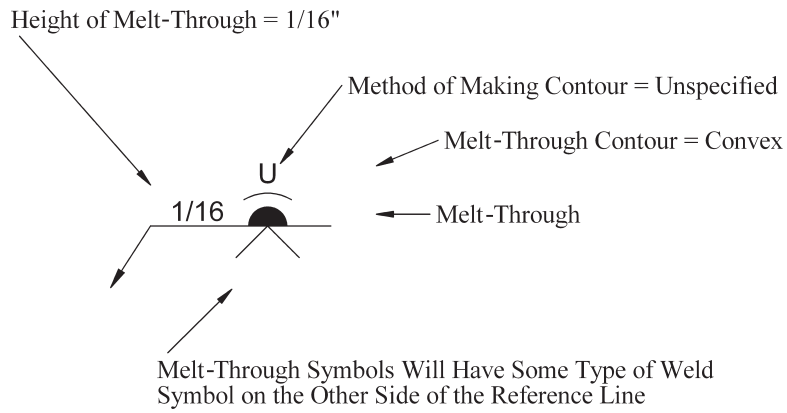
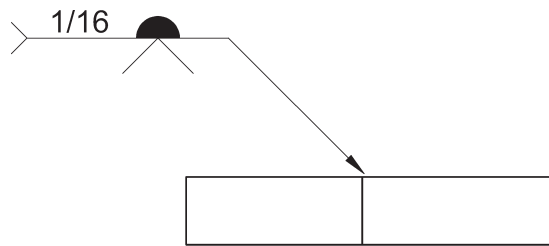
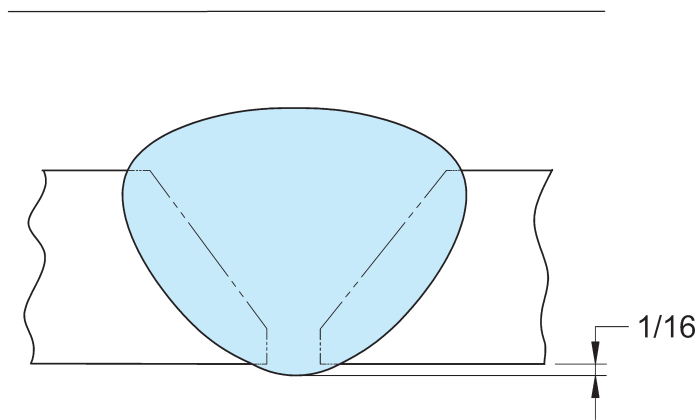

Figure 10-20 Welding Symbol with Melt-Through



This Shown on the Drawing



Means This

Figure 10-21 Melt-Through Example

CONSUMABLE INSERT

A **consumable insert** is preplaced filler metal that is fused into the root of the joint. Consumable inserts come in five different classes. The five classes correlate to the following five shapes:

1. Class 1: Inverted T cross section
2. Class 2: J shaped cross section
3. Class 3: Solid ring shape
4. Class 4: Y shaped cross section
5. Class 5: Rectangular shaped cross section

The class number (1, 2, 3, 4, or 5) required for the application should be shown in the tail of the welding symbol (see Figure 10-22). AWS A5.30/A5.30M:2007 Specification for Consumable Inserts further defines and specifies the requirements of the five classes of consumable inserts.

BACKING

Backing refers to placing something against a weld joint to support the molten metal. In most cases, it is placed against the backside of the weld joint, thus the term *backing*. For certain instances, however, like electroslag and electrogas welding, it can be used on both sides of the weld joint because both sides of the joint have molten metal at the same time and both sides must be supported. There are many types of backing, including backing bar or backup bar, backing pass, backing weld, backing ring, backing shoe, and backing strip. There are many methods for applying backing. Backing can be made from material that

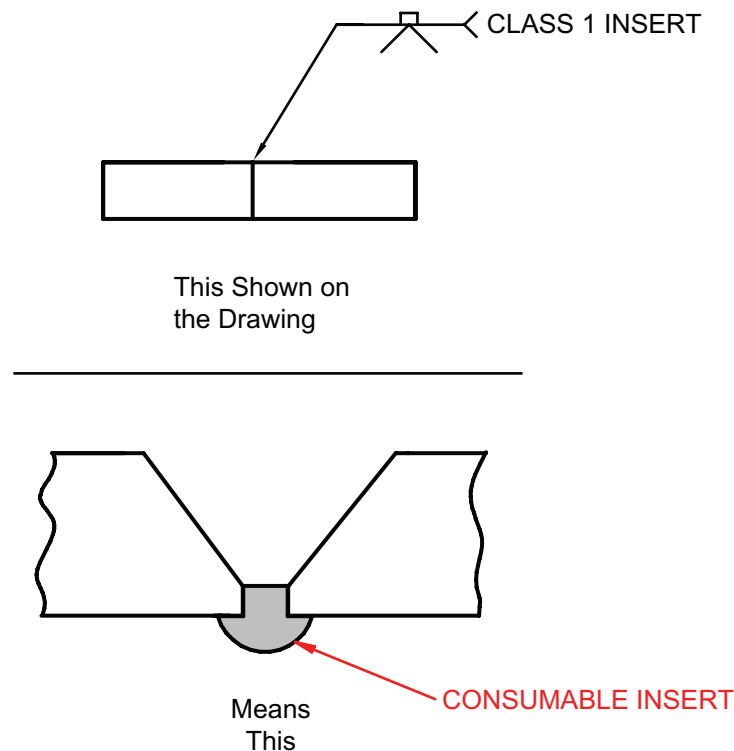

Figure 10-22 Melt-Through Example

will fuse into the weld or it can be made from material that will not fuse into the weld. Fused backing can be required to be removed after welding or left on to become part of the completed weld joint. When backing is to be removed after welding, an "R" is placed within the perimeter of the backing symbol. Figure 10-23 shows a backing symbol with an "R," indicating backing material that is to be removed after welding. Figure 10-24 shows a welding symbol and

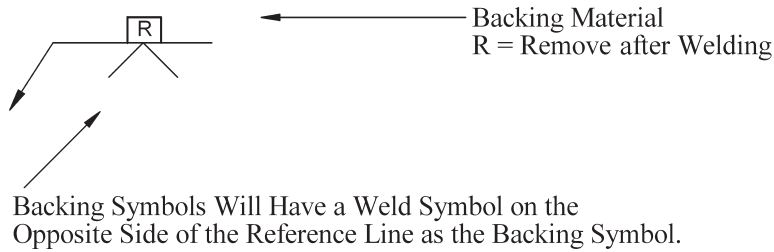
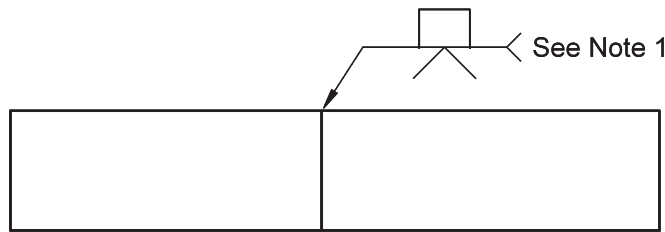
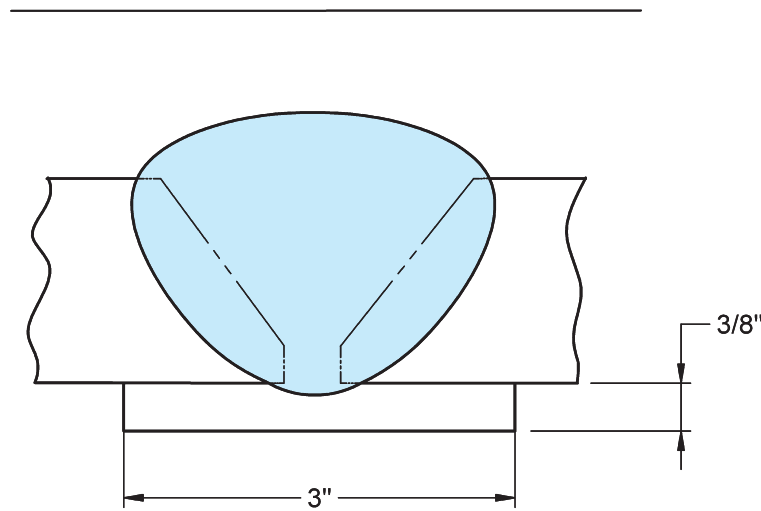

Figure 10-23 Welding Symbol with Backing Material

Note: 1. Backing Strip to be $3/8" \times 3"$ CS



This Shown on the Drawing



Means This

Figure 10-24 Backing Strip Weld

weld for a joint that is to have a backing strip that is to be left on after welding. Notice there is no "R," used in this symbol.

SPACER

For certain applications, a **spacer** can be used between weld joint members. The requirement to use a spacer is shown by the spacer symbol, which is a rectangular box placed on the center of the reference line, as shown in Figure 10-25. When the spacer symbol is used, the size and type of material should be shown in the tail of the welding symbol.

BACKING WELDS AND BACK WELDS

Backing welds and back welds use the same weld symbol, which looks like an unshaded half circle. Determination of which type (backing weld vs. back weld) is required based on the symbol alone cannot be made. A note in the tail of the welding symbol may be provided to specify which type of weld is required, a multiple reference line may be used to indicate the sequence of operation, or it may be specified in the welding procedure. Height, contour, and method of contour are all types of information that can be added to the back or backing weld symbol. See Figure 10-26.

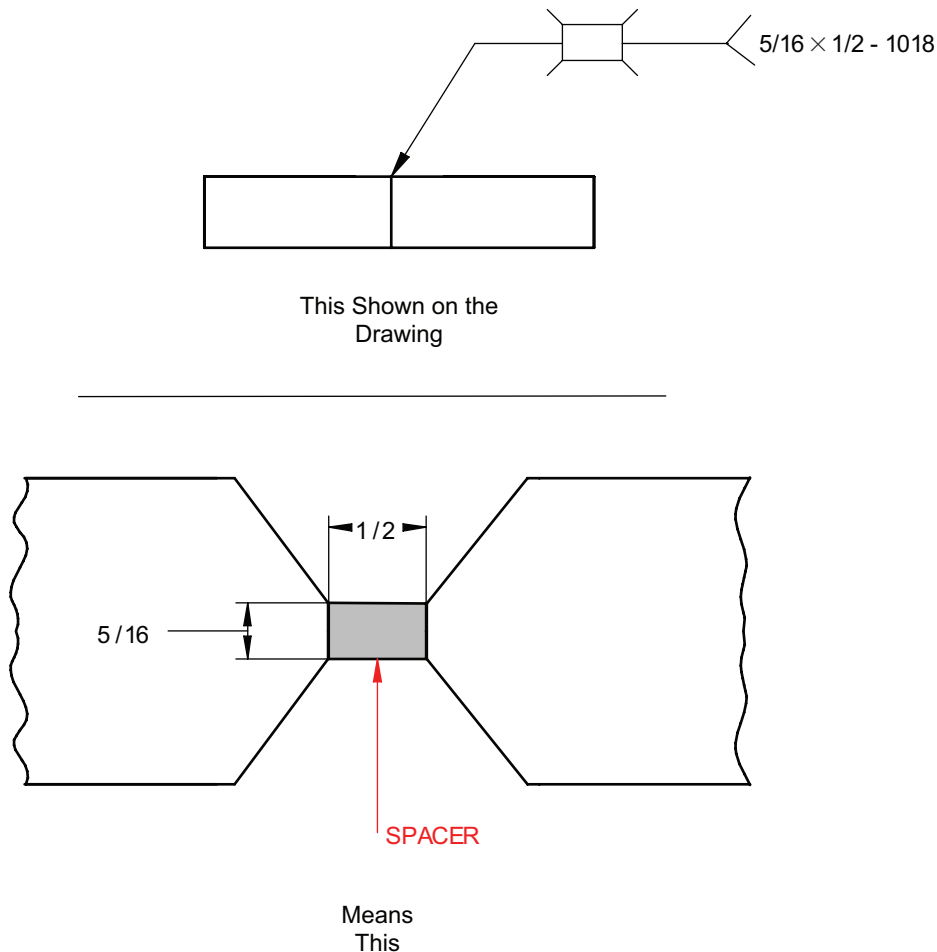

Figure 10-25 Spacer

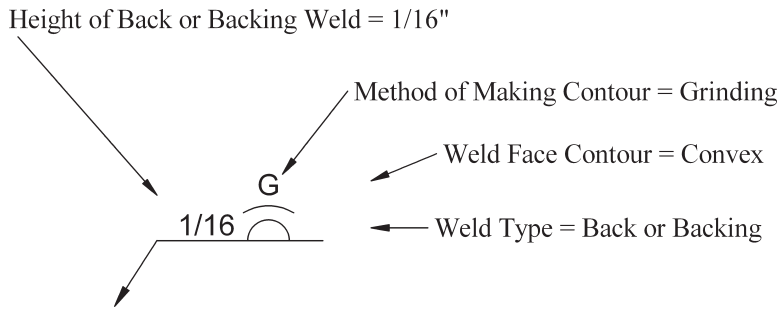

Figure 10-26 Backing Welds and Back Welds

EDGE WELDS

The welding symbol for an edge weld includes the edge weld symbol and when required, the following additional information: size, length, pitch, contour and method of finish. When the size of an edge weld is specified, it refers to the throat of the weld (the distance from the root to the face of the weld). Figure 10-27 shows the symbol for an edge weld with all of the supplemental information that may be used. Figure 10-28 shows the meaning of the weld size for an edge weld.

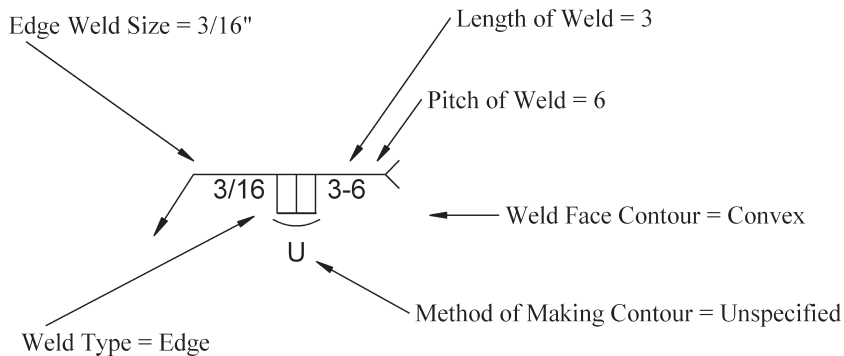

Figure 10-27 Edge Welding Symbol

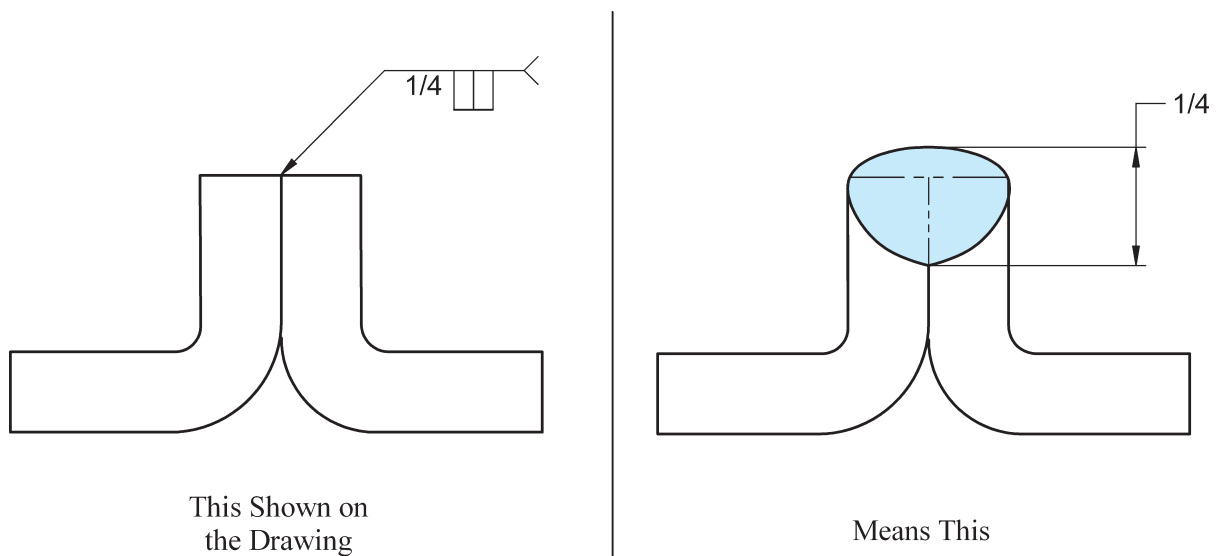

Figure 10-28 Edge Weld

SURFACING WELDS

The size of a surfacing weld is determined by its height from the substrate to the face of the weld. The weld direction of surfacing welds is identified in the tail of the welding symbol by the terms *axial*, *circumferential*, *longitudinal*, and *lateral*, or it may be identified in a welding procedure. See Figure 10-29. Examples of surfacing weld placement direction are shown in Figure 10-30.

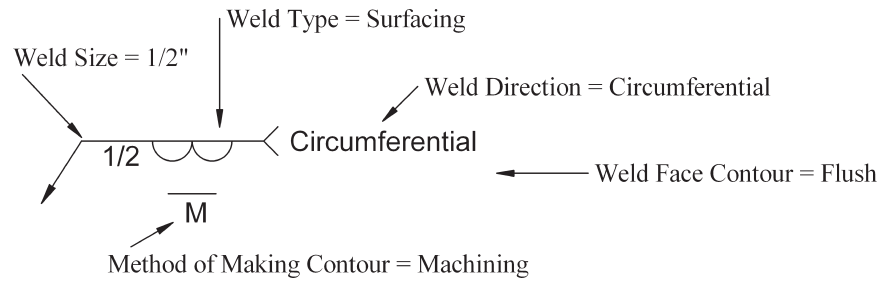

Figure 10-29 Surfacing Welding Symbol

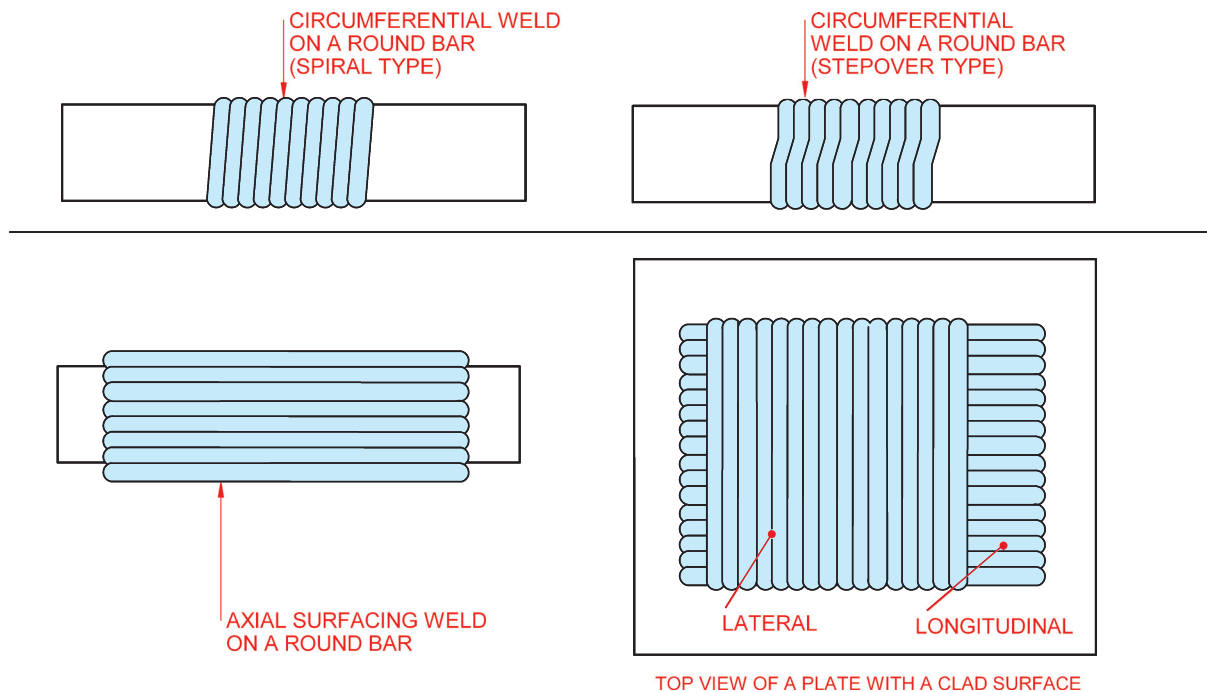

Figure 10-30 Surfacing Welds

SPOT AND PROJECTION WELDS

Figure 10-31 shows how the size, quantity, **pitch**, and process for spot welds are depicted. The size refers to the size of the weld at the junction of the faying surfaces of the materials being joined. Shear strength, given in pounds or newtons, may be used in place of the size dimension. There is no length dimension. As you saw in Chapter 9, the spot weld symbol may be placed on the arrow side or other side of the reference line, or it may straddle the line to indicate no arrow side or other side significance. Projection welds use the same symbol, size, quantity, and pitch designators, except projection welds should be shown only as arrow side or other side.

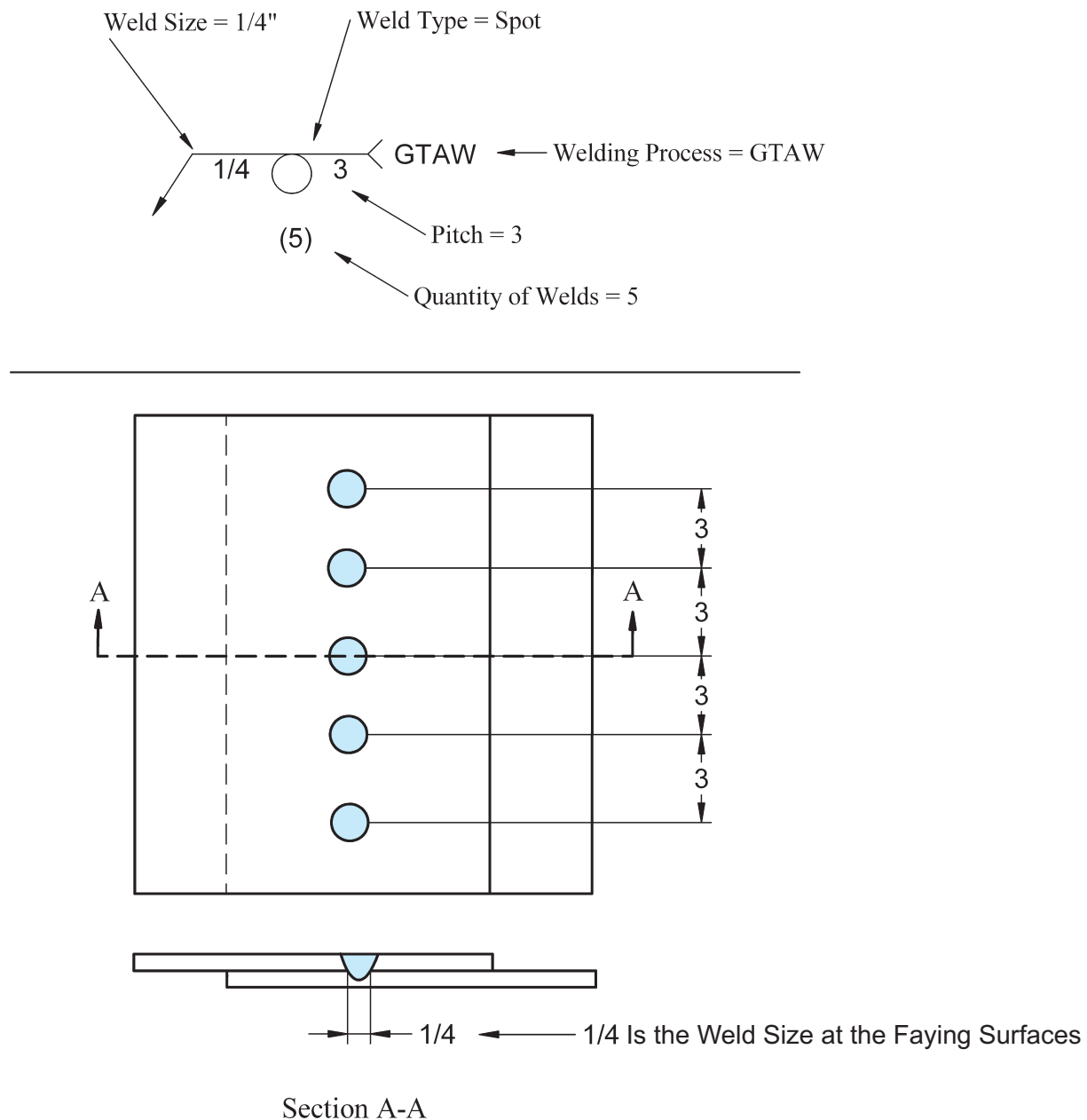

Figure 10-31 Welding Symbol Example for a Spot or Projection Weld

SEAM WELDS

The seam-welding symbol indicates a weld that takes place between the faying surfaces of a lap joint that may be composed of two or more lapped pieces. The weld is done typically by moving the lap joint between two rolling electrical contact wheels that pass current through the joint to create a type of rolling spot weld called a resistance seam weld (RSEW), or by a welding process that has enough arc energy to melt through one of the plates and weld down into the other(s). Seam welds can be made by making overlapping spot welds to form a seam. Figure 10-32 shows two different seam welding symbols with supplemental information that may be used.

Figure 10-33 shows two different ways that seam welds can be made: end to end or side by side. End to end is considered the way indicated by the welding symbol unless a separate detail indicates otherwise.

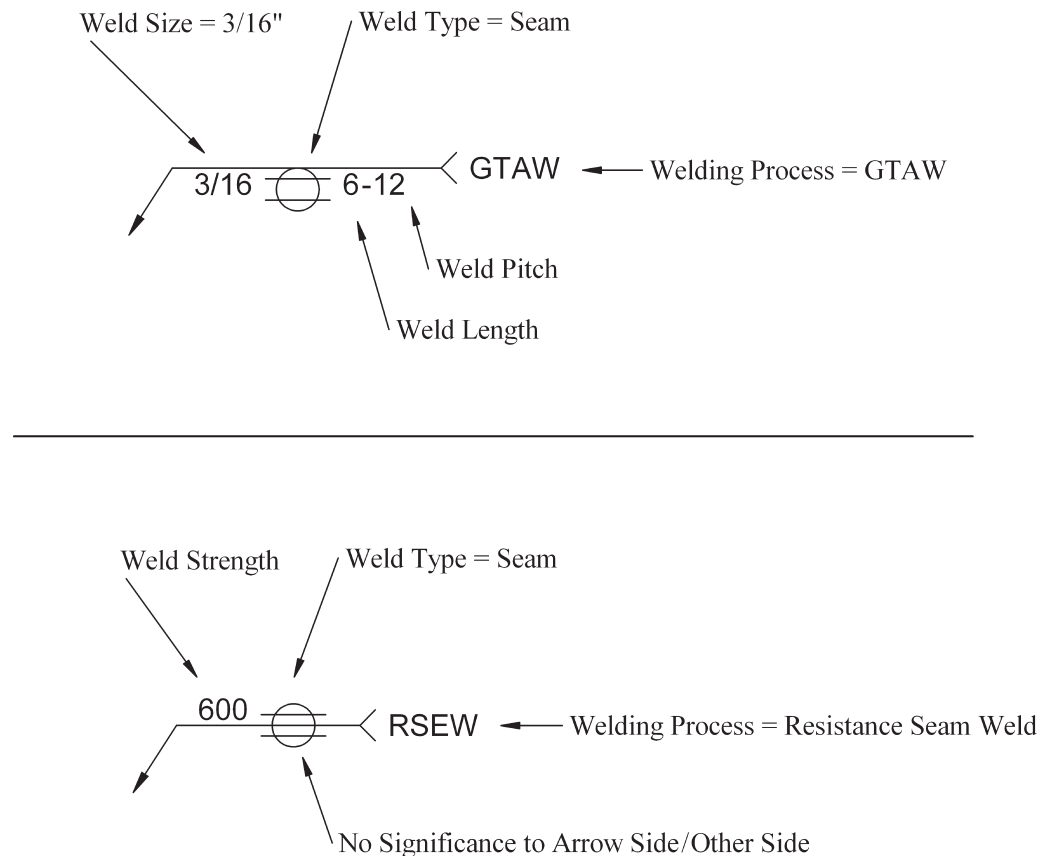

Figure 10-32 Welding Symbol Example for a Seam Weld

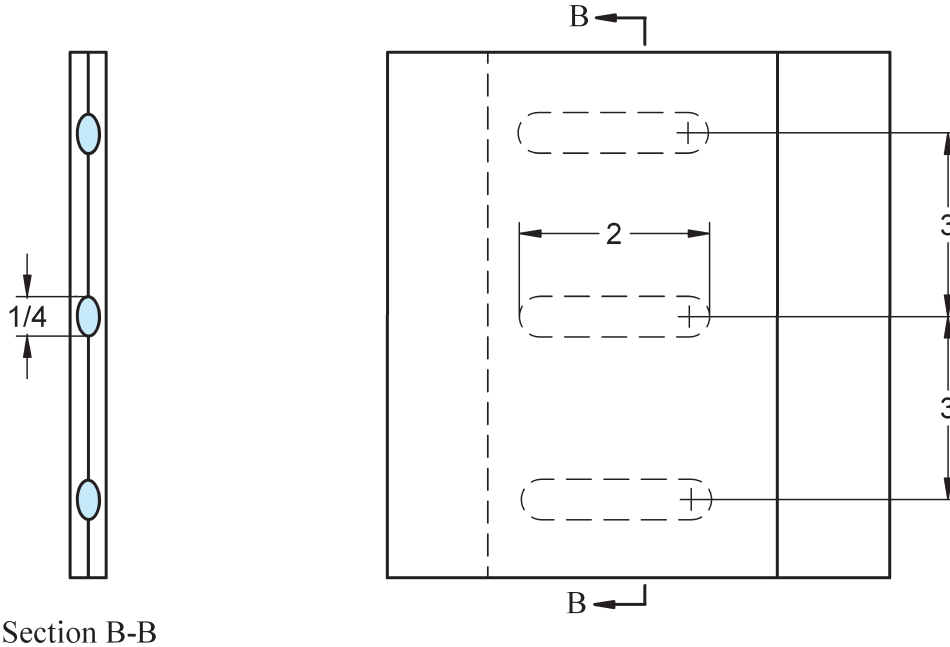
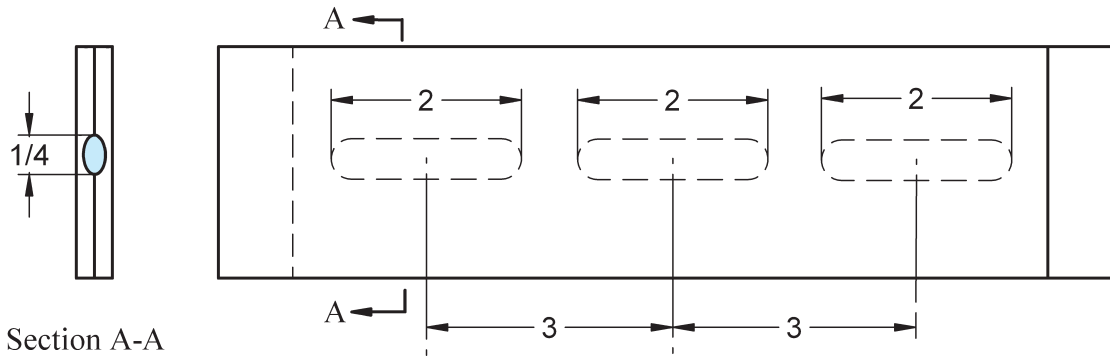
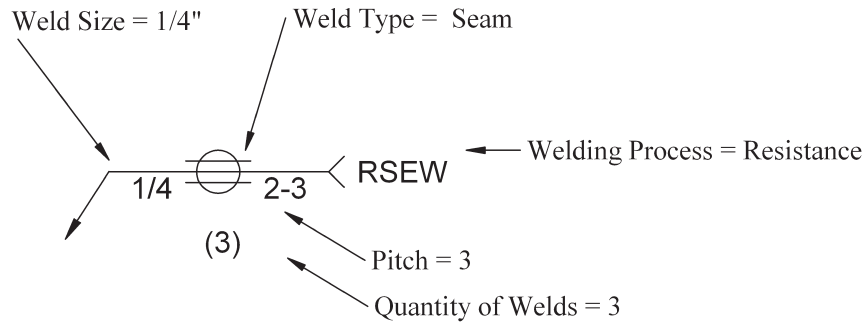
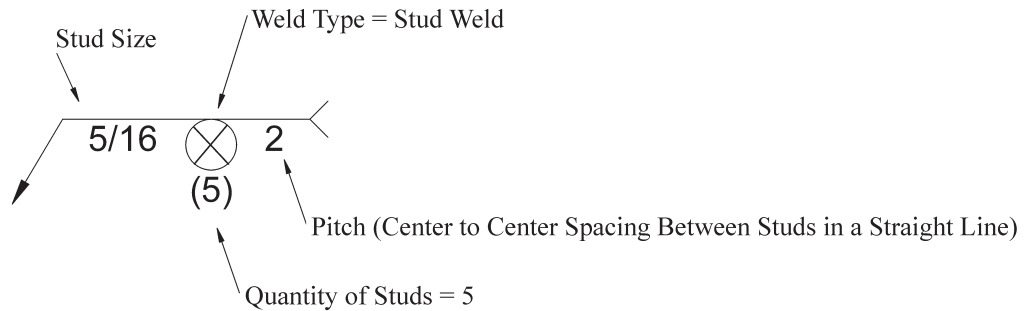

Figure 10-33 Different Configurations for Seam Welds

STUD WELDS

The basic information for stud welds is given in the welding symbol shown in Figure 10-34. Additional information on the specifics of the stud is provided, as necessary, by other means, such as a note, bill of material specification, or specification in the tail of the welding symbol.



Note: Stud Welds Are Only Shown Arrow Side.

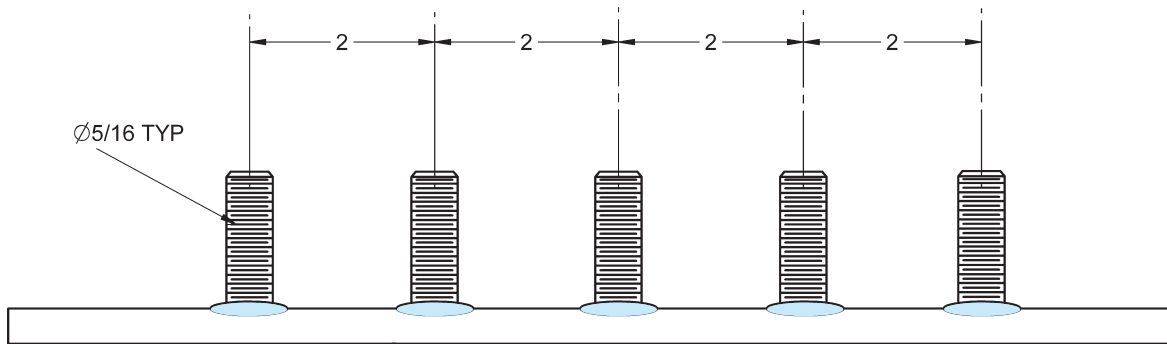

Figure 10-34 Welding Symbol Example for a Stud Weld

PLUG AND SLOT WELDS

Plug and slot symbols contain similar information except that plug welds do not have a length component and the size of a plug weld is its diameter whereas the size of a slot is its width. They may be completely filled or filled to a depth specified within the weld symbol. See Figure 10-35.

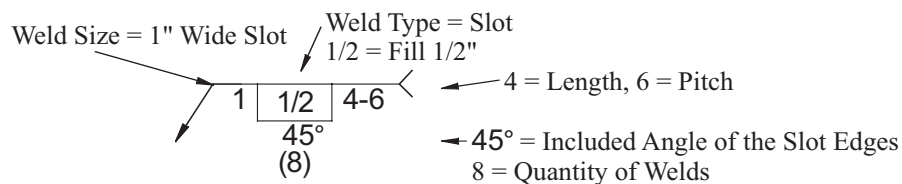
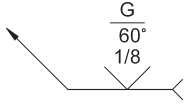

Figure 10-35 Slot Weld Symbol

CHAPTER 10

Practice Exercise 1

Describe completely all of the information contained in the following welding symbols.



1. _____

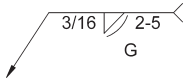

2. _____

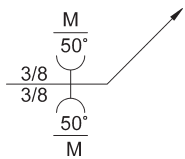

3. _____

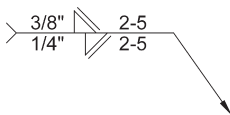

4. _____

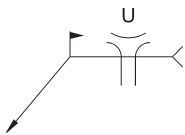

5. _____

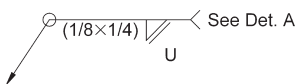

6. _____

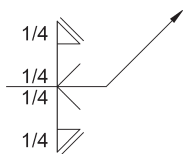

7. _____

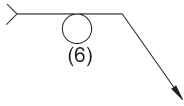

8. _____

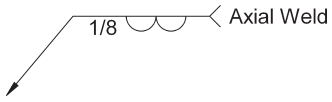

9. _____

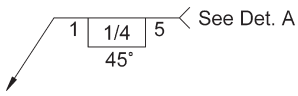

10. _____



11. _____

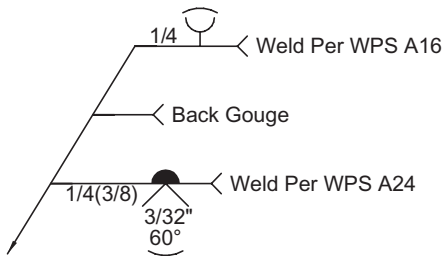

12. _____

CHAPTER 10

Practice Exercise 2

Refer to Drawing Number 08123101 on the previous page.

1. What is the minimum and maximum acceptable length of part A? Minimum _____
Maximum _____
2. Who approved this drawing? _____
3. Describe completely the weld required at joint F. _____

4. Give the I.D. sizes of the round bar that would be necessary for the bars MMC and LMC.
MMC _____ LMC _____
5. When are the holes to be machined? _____
6. What is the dimensioned thickness of part C? _____
7. Draw the welding symbol for the weld required at joint H.
8. Describe completely the weld required at joint E. _____

9. What is the maximum overall acceptable size of the rotating arm bar? _____
10. Describe completely the weld required at joint G. _____

11. What is the center-to-center distance between the two holes? _____
12. What is the specification for the required material? _____
13. What welding procedure is to be used at joint H? _____
14. How long is the round bar? _____
15. What are the dimensions of part B? _____
16. What is the overall maximum acceptable length of the rotating arm bar? _____

CHAPTER 10

Math Supplement

Additional Conversions

This supplement builds on the Chapter 9 Math Supplement by adding conversions in feet, inch, and fraction of an inch format. Review the Chapter 9 Math Supplement as needed for help in working the exercises. Also included is a section on converting between pounds and kilograms.

When converting lengths that include feet, inch, and fractions of an inch to the metric system, it is typically easiest to first convert feet to inches. When converting from the metric system, it is typically easiest to begin by converting to inches and then divide as required to get feet and inches.

Example 1: Convert $16'4\frac{9}{16}"$ to meters.

Step 1: Convert 16' to inches. We know that $12" = 1'$, so multiply 16' by 12" to obtain 192".

Step 2: Add 4" to the 192" from step 1 to get 196"

Step 3: Change the common fraction $\frac{9}{16}$ to the decimal .5625 by dividing 9 by 16.

Step 4: Add .5625" to 196" to get 196.5625"

Step 5: Multiply 196.5625" by .0254 meters/inch to obtain the final answer of 4.9927 meters.

Note: 4.9927 meters equals 499.27cm which equals 4992.7 mm.

Example 2: Convert 752 millimeters to feet, inches and fractions of inch, to the nearest sixteenth.

Step 1: Convert 752 millimeters to inches by multiplying 752mm by .03937 to get 29.60624"

Step 2: Set aside the .60624 decimal portion of your answer until Step 5.

Step 3: Divide 29" by 12"/foot to get 2' with a remainder of 5".

Step 4: Consolidate the answer from step 3 above into 2'5".

Step 5: Multiply .60624" from step 2 by 16 to obtain 9.69984 sixteenths.

Step 6: Round 9.69984 sixteenths to the nearest full sixteenth which is 10.

Step 7: Simplify $\frac{10}{16}$ to $\frac{5}{8}$ by dividing both the numerator and denominator by 2.

Step 8: Add the $\frac{5}{8}$ to the 2'5" found in Step 4 above to obtain the final answer of 2'5 $\frac{5}{8}"$.

Note: Rounding a decimal portion of an inch to a specific fractional denomination is easily accomplished as shown above in steps 5 and 6 by multiplying the decimal by the denomination required and then rounding to the nearest whole number.

Converting and Estimating Weights of Common Metal Used in Fabrication

Many times it is necessary for welding and fabricating personnel to know what the weight of a weldment is. Weights of the items shown on drawings are typically given either in the bill of materials area of the drawing or as a note somewhere on the drawing. The units used are typically either pounds or kilograms.

One kilogram equals approximately 2.204623 pounds. We will use the approximation of 2.205 for the purposes of completing the problems in this text. Use additional numbers as required following the decimal point if greater accuracy is needed.

To convert from:

Kilograms to (approximate) pounds: Multiply the number of kilograms by 2.205.

Pounds to (approximate) kilograms: Divide the number of pounds by 2.205.

If the weights of the objects are not shown on the drawing, their approximate weight can be calculated if the weight per cubic inch of material is known. To find the number of cubic inches of material, multiply the length by the width by the height of the material ($L \times W \times H$). The following list shows the approximate weight per cubic inch of some of the common materials a welder/fabricator may work with. *Note: These approximations may change depending on the alloy used. Consult with your material supplier for exact weights.*

Approximate weight of 1 cubic inch of: Steel = .284 lb.

Approximate weight of 1 cubic inch of: Stainless Steel = .287 lb.

Approximate weight of 1 cubic inch of: Cast Iron = .26 lb.

Approximate weight of 1 cubic inch of: Aluminum = .098 lb.

Approximate weight of 1 cubic inch of: Magnesium = .061 lb.

Approximate weight of 1 cubic inch of: Brass = .31 lb.

Example 3: Calculate the approximate weight of a steel plate that is 37" long \times 18" wide \times $\frac{1}{2}$ " thick. Provide your answer in both pounds and kilograms.

Step 1: Determine the cubic inches of steel. $37 \times 18 \times .5 = 333$ cubic inches.

Step 2: Multiply 333 cubic inches by .284 pounds per cubic inch to get an answer of 94.572 pounds.

Step 3: Divide 94.572 pounds by 2.205 kilograms per pound to get an answer of 42.89 kilograms.

CHAPTER 10

Math Supplement Practice Exercise 1

Convert the following. Write your answers in the spaces provided.

1.	11'8" to inches	_____ inches
2.	175¾" to feet and inches	_____ feet _____ inches
3.	4.5 meters to inches	_____ inches
4.	1 meter to centimeters	_____ centimeters
5.	1 meter to millimeters	_____ millimeters
6.	65mm to centimeters	_____ centimeters
7.	17'5¾" to inches	_____ inches
8.	3'11¾" + 4'4¾" to inches	_____ inches
9.	1.2 meters + 24 mm to inches	_____ inches
10.	45'6" + 4'4¾" to inches	_____ inches
11.	85cm – 19mm to feet and inches	_____ feet _____ inches
12.	47 kilograms to pounds	_____ pounds
13.	1250 pounds to kilograms	_____ kilograms
14.	95.5 kilograms to pounds	_____ pounds
15.	720 pounds + 450 kilograms to kilograms	_____ kilograms