

Standard elongated hole, small type

BGS-S series, BGS-2S series



Standard elongated hole type and small type BGS sensors

- | For locations with small mounting space
- | For accurate detection of small workpieces
- | High-speed response: 0.5 ms

Related products

C-MOS laser
**BGS-HL,
BGS-HDL**
● P.310



Laser type
BGS-ZL
● P.326



Stainless steel type
BGS-ZM
● P.334



Detection of electronic parts in trays

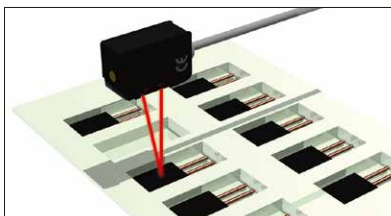

Detection of pills

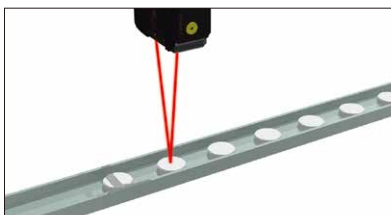



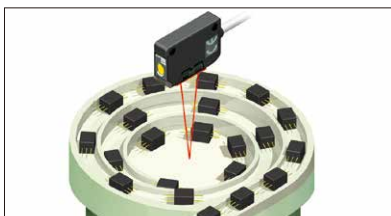



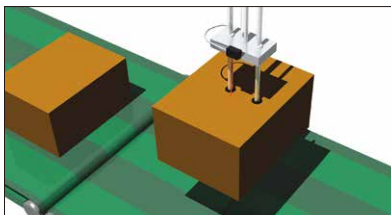

Detection of remaining parts on parts feeder



Detection of objects held by manipulator



Selection table

Type	Shape	Sensing distance (Adjustable distance range shown in parentheses)	Model (Models in parentheses are connector types)	
			NPN type	PNP type
BGS		 10 to 50 mm (10 to 30 mm)	BGS-S03N	BGS-S03P
		 10 to 80 mm (10 to 80 mm)	BGS-S08N (BGS-S08CN)	BGS-S08P (BGS-S08CP)
		 8 to 100 mm (20 to 100 mm)	BGS-2S10N	BGS-2S10P
		 0 to 150 mm (50 to 150 mm)	BGS-2S15N (BGS-2S15CN)	BGS-2S15P (BGS-2S15CP)
		 5 to 300 mm (25 to 300 mm)	BGS-2S30N (BGS-2S30CN)	BGS-2S30P (BGS-2S30CP)
		 5 to 300 mm (25 to 300 mm)	BGS-2S30NT	BGS-2S30PT

● For the connector type, please purchase an optional JCN series connector cable.

Options/Accessories

Connector cables
Straight



- M84CN-2S**
Cable length: 2 m
- M84CN-5S**
Cable length: 5 m
- M84CN-10S**
Cable length: 10 m

L-shaped



- M84CN-2L**
Cable length: 2 m
- M84CN-5L**
Cable length: 5 m
- M84CN-10L**
Cable length: 10 m

Protective mounting bracket
For BGS-S03□, -S08□

LS-501



LS-502



Sensor stand
Sensor stand

(Image is for flat surface mounting)

- PLN-1**
Reflector mounting bracket
for PLN-1
- PLN-1M**
PLN description
● P.242



For BGS-2S□□□

LS2-S01



Standard elongated hole, small type **BGS-S, BGS-2S** series

Can be safely used in locations with small mounting space

Small type

BGS-S series is one of the smallest distance setting type photoelectric sensors. BGS sensors can now be used in locations where only small-sized diffuse-reflective type photoelectric sensors could be used up to now.



Prevention of chattering

Type with timer functions

The BGS-2S30NT is equipped with an OFF delay timer which can delay the time in which output is shut off by 0 to 100 ms. It is also effective when inputting to devices in which detecting signal slow.

OFF delay timer ▶

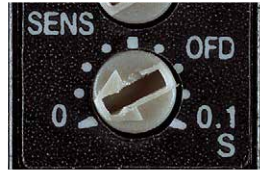

High-speed response

0.5 ms high-speed response type

This photoelectric sensor with built-in amplifier features a top level response time of 0.5 ms or less. This feature makes its use on high speed production lines possible.



Water resistant structure

Degree of protection on IP67

All models in the BGS series conform to IP67 (protective resistance standard) and feature excellent dust and water resistance. It also conforms to CE standards and can be used in a wide range of locations.



For accurate detection of small workpieces

Small spot type (BGS-S03N)

BGS-S03N is equipped with a very small light spot which helps to detect small objects like electronic components. (at distance of 30 mm)

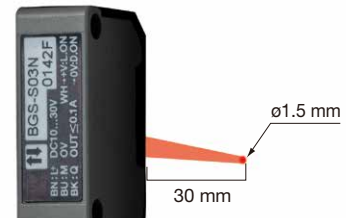

Direct output

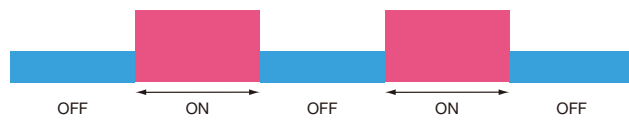

OFF delay output

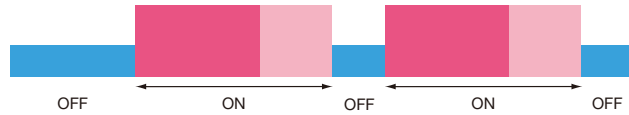

For accurate detection of substrates

Substrate detection type (BGS-2S10N)

Features of this type include stable detection even if the substrate type is changed, as well as high repeat accuracy, even among models in the series.

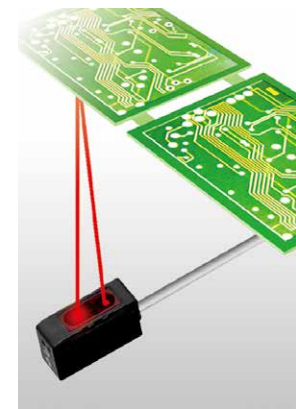

Photoelectric Sensors

Specialized Photoelectric Sensors

Laser Displacement Sensors

BGS Sensors

BGS-HL, BGS-HDL

BGS-DL

BGS-ZL, BGS-Z

BGS-ZM

BGS-S, BGS-2S

BGS

BGS-DL (potentiometer type)

Specifications

Type		Short-range (small spot)	Short-range
Model	NPN	Cable type	BGS-S03N
		Connector type	—
	PNP	Cable type	BGS-S03P
		Connector type	—
Sensing distance	White paper	10 to 50 mm	10 to 80 mm
	Gray paper	8 to 30 mm	10 to 80 mm
	Black paper	8 to 20 mm	10 to 70 mm
Light source		Red LED	
Response time		0.5 ms or less	
Repeat accuracy		Light axis direction: 0.1 mm Vertical direction: 0.3 mm	Light axis direction: 0.2 mm Vertical direction: 0.2 mm
Hysteresis		10% or less	
Distance adjustment		5-turn endless potentiometer	
Indicators		Output indicator (orange), Stability indicator (green)	
Control output		NPN/PNP type open collector Max. 100 mA/30 VDC	
Output mode		Light ON / Dark ON switched by wiring	
Connection type		Cable type: Cable length: 2 m ø3.5 mm / Connector type: M8, 4-pin	
Insulation resistance		20 MΩ or more (with 500 VDC)	
Rating	Supply voltage	10 to 30 VDC, including 10% ripple (p-p)	
	Current consumption	20 mA or less	
Applicable regulations		EMC directive (2004/108/EC)	
Applicable standards		EN 60947-5-2	
Company standards		Noise resistance: Feilen Level 4 cleared	
Environmental resistance	Ambient temperature/humidity	-25 to +55°C (no freezing) / 35 to 85% RH (no condensation)	
	Ambient illuminance	Sunlight: 10,000 lx or less Incandescent lamp: 3,000 lx or less	
	Vibration resistance	10 to 55 Hz; double amplitude 1.5 mm; 2 hours in each of the X, Y, and Z directions	
	Shock resistance	Approx. 50 G (500 m/s ²), 3 times in each of the X, Y, and Z directions	
Degree of protection		IEC standard, IP67	
Material		Housing: ABS (glass fiber filled, fire resistant), Front cover: Polycarbonate	
Weight without cable		Approx. 6 g	Approx. 9 g
Included accessories		Mounting bracket: BEF-W150-B	

● Specifications are subject to change without prior notice for product improvement purposes.

		Type	Short-range	Mid-range	Mid-range	Mid-range (with timer function)
Model	NPN	Cable type	BGS-2S10N	BGS-2S15N	BGS-2S30N	BGS-2S30NT
		Connector type	—	BGS-2S15CN	BGS-2S30CN	—
	PNP	Cable type	BGS-2S10P	BGS-2S15P	BGS-2S30P	BGS-2S30PT
		Connector type	—	BGS-2S15CP	BGS-2S30CP	—
Sensing distance	White paper		3 to 100 mm	0 to 150 mm	5 to 300 mm	5 to 300 mm
	Gray paper		8 to 100 mm	25 to 150 mm	10 to 300 mm	10 to 300 mm
	Black paper		15 to 90 mm	25 to 80 mm	15 to 200 mm	15 to 200 mm
Light source		Red LED				
Response time		0.5 ms or less				
Repeat accuracy		Light axis direction: 0.1 mm Vertical direction: 0.3 mm		Light axis direction: 2.5 mm Vertical direction: 0.6 mm		
Hysteresis		10% or less				
Distance adjustment		6-turn endless potentiometer				5-turn endless potentiometer
Timer function		—				OFF delay timer 0 to 100 ms (variable)
Indicators		Output indicator (orange), Stability indicator (green)				
Control output		NPN/PNP type open collector Max. 100 mA/30 VDC				
Output mode		Light ON / Dark ON selectable				Light ON / Dark ON switched by wiring
Connection type		Cable type: Cable length: 2 m ø3.8 mm Connector type: M8, 4-pin				Cable type: Length: 2 m ø3.5 mm
Insulation resistance		20 MΩ or more (with 500 VDC)				
Rating	Supply voltage		10 to 30 VDC, including 10% ripple (p-p)			
	Current consumption		30 mA or less			20 mA or less
Applicable regulations		EMC directive (2004/108/EC)				
Applicable standards		EN 60947-5-2				
Company standards		Noise resistance: Feilen Level 3 cleared				Noise resistance: Feilen Level 4 cleared
Environmental resistance	Ambient temperature/humidity		-25 to +55°C (no freezing) / 35 to 85% RH (no condensation)			
	Ambient illuminance		Sunlight: 10,000 lx or less Incandescent lamp: 3,000 lx or less			
	Vibration resistance		10 to 55 Hz; double amplitude 1.5 mm; 2 hours in each of the X, Y, and Z directions			
	Shock resistance		Approx. 50 G (500 m/s ²), 3 times in each of the X, Y, and Z directions			
	Degree of protection		IEC standard, IP67			
Material		Housing: ABS (glass fiber filled, fire resistant), Front cover: Polycarbonate				Housing: ABS (glass fiber filled, heat resistant) Front cover: Polycarbonate
Weight without cable		Approx. 6 g				Approx. 9 g
Included accessories		Mounting bracket: BEF-W140-B				

● Specifications are subject to change without prior notice for product improvement purposes.

Photoelectric Sensors

Specialized Photoelectric Sensors

Laser Displacement Sensors

BGS Sensors

BGS-HL,
BGS-HDL

BGS-DL

BGS-ZL,
BGS-Z

BGS-ZM

BGS-S,
BGS-2S

BGS

BGS-DL
(potentiometer type)

Distance adjustment

	Order	Diagram	Potentiometer	Light receiving indicator	Adjustment procedure
BGS	1			ON 	Set the object in the detection position and gradually raise the distance adjustment from the minimum to position A where the indicator will light up.
	2			OFF 	Remove the object and gradually lower the distance adjustment from the maximum to position B where the indicator will turn on.
	3			ON 	Position C between positions A and B is the optimal position for threshold. Positions A and B may be reversed depending on the model and the detection conditions. Place the workpiece in a fixed position and perform an operational check.

Photoelectric Sensors

I/O circuit diagram

NPN output type

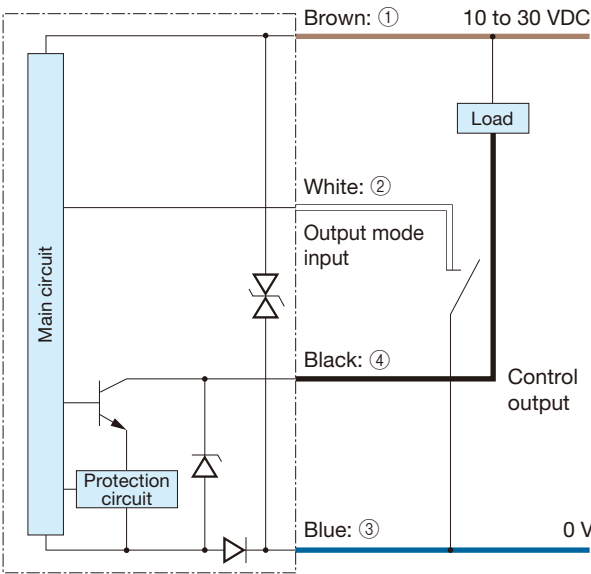

PNP output type

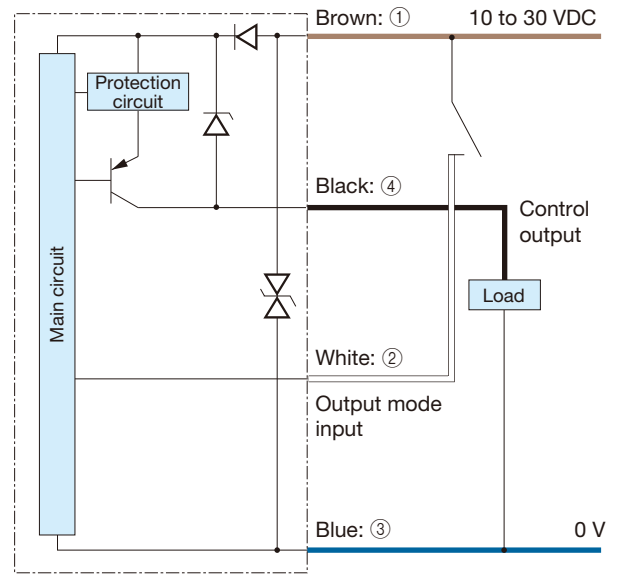

*White lead wire: ② is only equipped to BGS-S03□, -S08□, -2S30□T

Connector type

(Pin configuration)

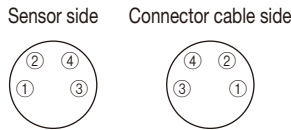

- ① 10 to 30 VDC
- ② Not connected/+V: Light ON (NPN)
0 V: Dark ON
- ③ 0 V
- ④ Control output

*Pin No. ② is not used for BGS-2S10□, -2S15□, -2S30□.

Connecting

- Turns to Light ON mode when the white wire is connected to +V or not connected and to Dark ON mode when connected to 0 V (for NPN). To use without connecting, disconnect and wrap individually with insulating tape, etc. Do not connect it to any other terminal.
- ① to ④ are connector pin No.

Notes

- When using a switching regulator for the power supply, be sure to ground the frame ground terminal.
- Avoid wiring in parallel with or in the same piping as high-voltage wires or power lines. Doing so may lead to malfunctions caused by noise. Also, shorten the power supply and signal wires as much as possible.
- Avoid using the transient state while the power is on (approx. 100 ms).
- The connector direction is fixed as in the drawing to the right when you use L-shaped connector cable. Be aware that rotation is not possible.

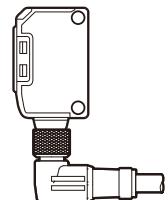

Photoelectric Sensors

Specialized Photoelectric Sensors

Laser Displacement Sensors

BGS Sensors

BGS-HL, BGS-HDL

BGS-DL

BGS-ZL, BGS-Z

BGS-ZM

BGS-S, BGS-2S

BGS

BGS-DL (potentiometer type)

Dimensions

Sensor (BGS-S03□, -S08□)

(Unit: mm)

■ Cable type

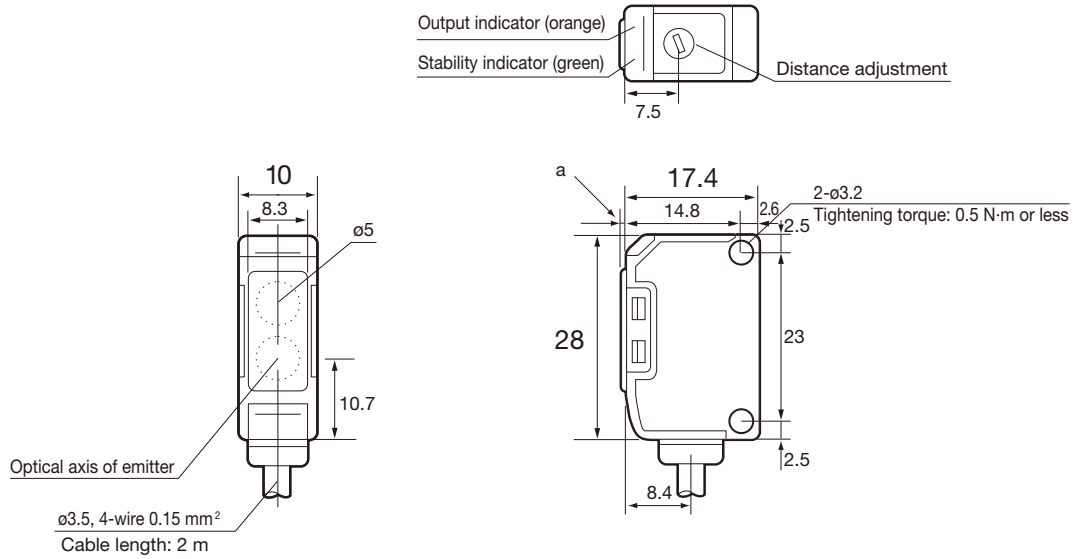

■ Connector type

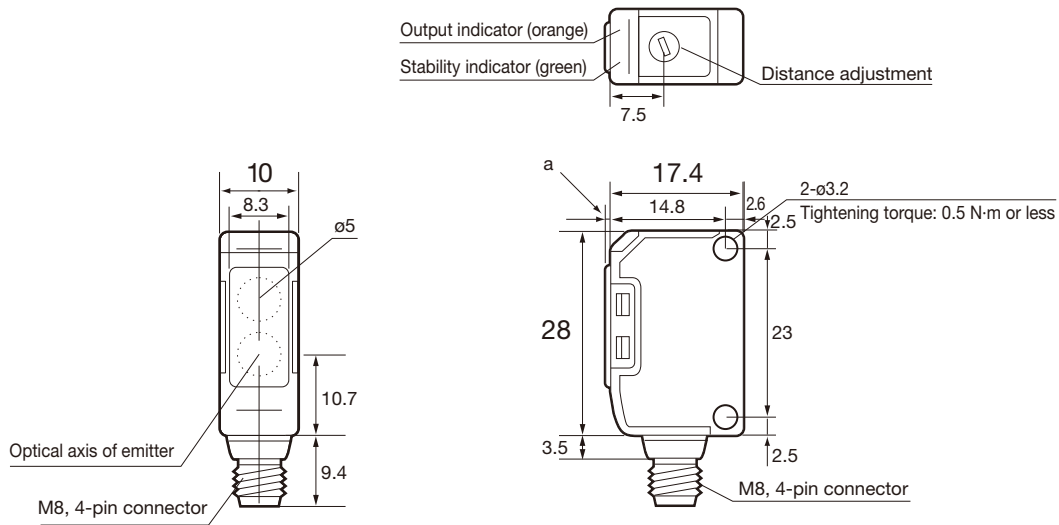

	BGS-S08□	BGS-S03□
a	1	2.4

Standard elongated hole, small type **BGS-S, BGS-2S** series

Dimensions

Mounting bracket (BGS-S03□, -S08□)

(Unit: mm)

■ Cable type (when using included BEF-W150-B)

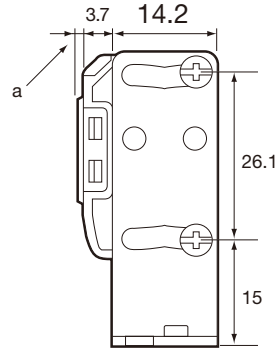
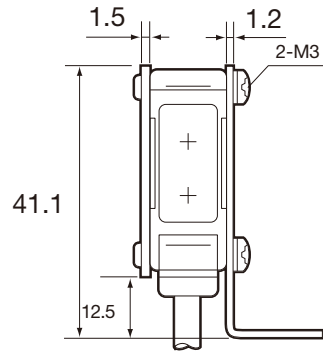
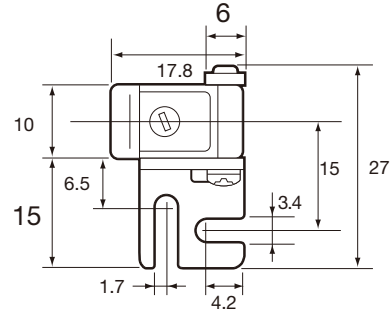

■ Connector type (when using optional BEF-W150-A)

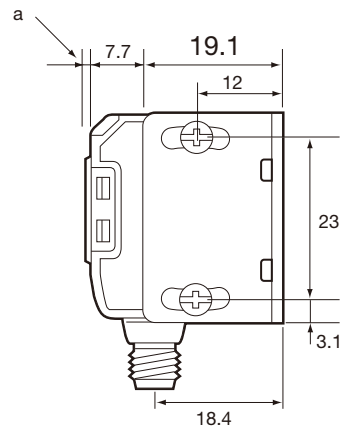
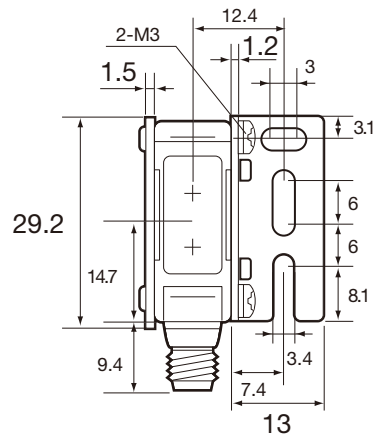
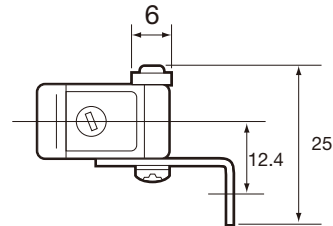

	BGS-S08□	BGS-S03□
a	1	2.4

Sensor (BGS-2S□□□)

(Unit: mm)

■ Cable type

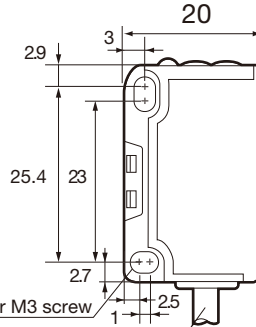
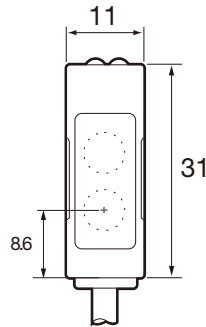
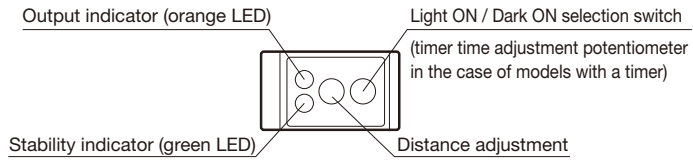

Mounting hole for M3 screw
 ø3.8, 3-wire × 0.18 mm²
 BGS-2S30NT only ø3.8, 4-wire × 0.18 mm²

Mounting bracket (BGS-2S□□□)

■ Cable type
 (when using included BEF-W140-B)

■ Connector type
 (when using optional BEF-W140-A)

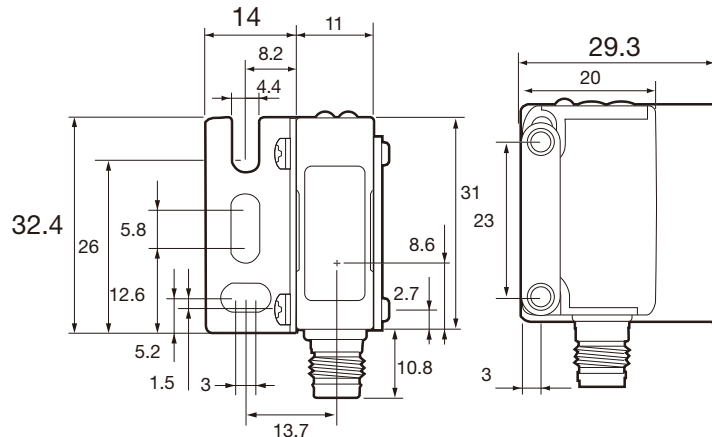
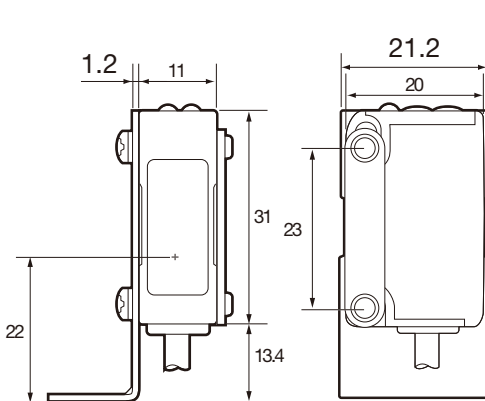
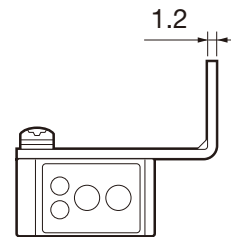
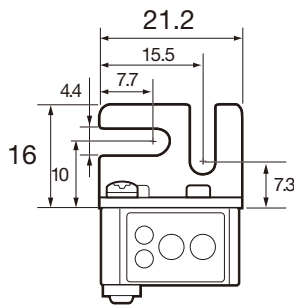

Photoelectric Sensors

Specialized Photoelectric Sensors

Laser Displacement Sensors

BGS Sensors

BGS-HL, BGS-HDL

BGS-DL

BGS-ZL, BGS-Z

BGS-ZM

BGS-S, BGS-2S

BGS

BGS-DL (potentiometer type)

Standard elongated hole, small type **BGS-S, BGS-2S** series

Dimensions

Connector cable (optional)

■ JCN-S, JCN-5S, JCN-10S

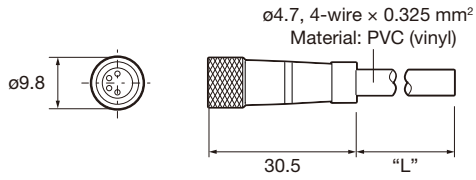

■ JCN-L, JCN-5L, JCN-10L

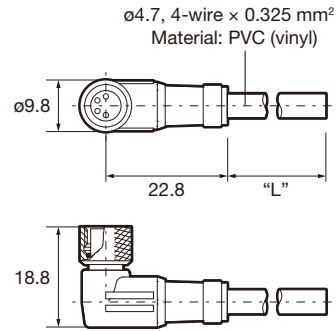

(Unit: mm)

Photoelectric Sensors

Specialized Photoelectric Sensors

Laser Displacement Sensors

BGS Sensors

BGS-HL,
BGS-HDL

BGS-DL

BGS-ZL,
BGS-Z

BGS-ZM

**BGS-S,
BGS-2S**

BGS

BGS-DL
(potentiometer type)

Typical characteristic data

* Please contact a sales representative for any other characteristic data that may be required.

BGS-S03 □, **BGS-S08** □

— BGS-S03 □ — BGS-S08 □

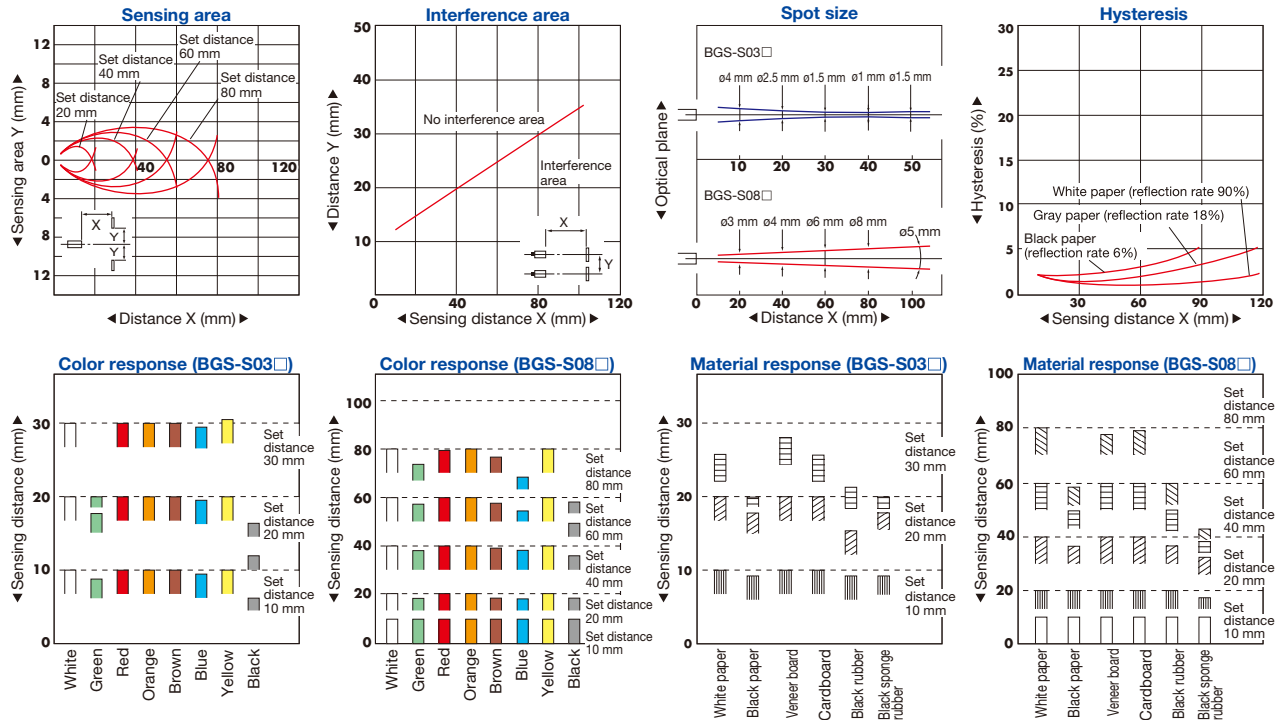

BGS-2S15 □, **BGS-2S30** □

— BGS-2S15 □ — BGS-2S30 □

