

ELMO

PAN • TILT • ZOOM COLOR CAMERA

PTC-401C IP



INSTRUCTION MANUAL

Please read this instruction manual carefully before using PTC-401C IP and keep it for future reference.

IMPORTANT SAFETY INSTRUCTIONS

1. Read these instructions.
2. Keep these instructions.
3. Heed all warnings.
4. Follow all instructions.
5. Do not use this apparatus outdoors.
6. Do not use this apparatus near water.
7. Clean only with dry cloth.
8. Do not install near heat sources such as radiators, heat registers, stoves or other apparatus (including amplifiers) that produce heat.
9. Do not touch this apparatus during lightning storms.
10. Unplug when unused for long periods of time.
11. Refer all servicing to qualified personnel. Servicing is required when the apparatus has been damaged in any way, such as power-supply cord or plug is damaged, liquid has been spilled or objects have been fallen onto the apparatus, the apparatus has been exposed to rain or moisture, does not operate normally, or has been dropped.

WARNING: Handling the cord on this product or cords associated with accessories sold with this product, will expose you to lead, a chemical known to the State of California to cause birth defects or other reproductive harm.
Wash hands after handling.

	CAUTION RISK OF ELECTRIC SHOCK DO NOT OPEN	
<p>CAUTION : TO REDUCE THE RISK OF ELECTRIC SHOCK. DO NOT REMOVE COVER (OR BACK). NO USER SERVICEABLE PARTS INSIDE. REFER SERVICING TO QUALIFIED SERVICE PERSONNEL.</p>		



The lightning flash with arrowhead symbol, within an equilateral triangle, is intended to alert the user to the presence of uninsulated "dangerous voltage" within the product's enclosure that may be of sufficient magnitude to constitute a risk of electric shock to persons.



The exclamation point within an equilateral triangle is intended to alert the user to the presence of important operating and maintenance (servicing) instructions in the literature accompanying the appliance.

CAUTION

- Do not use any power supply other than specified.

WARNING

TO REDUCE THE RISK OF FIRE OR ELECTRIC SHOCK, DO NOT EXPOSE THIS APPLIANCE TO RAIN OR MOISTURE.

- * The CAUTION label is attached on the base of product.

INFORMATION

This equipment has been tested and found to comply with the limits for Class B digital device, pursuant to Part 15 of the FCC Rules. These limits are designed to provide reasonable protection against harmful interference when the equipment is operated in a commercial environment.

This equipment generates, use, and can radiate radio frequency energy and, if not installed and used in accordance with the instruction manual, may cause harmful interference to radio communications. Operation of this equipment in a residential area is likely to cause harmful interference in which case the user will be required to correct the interference at his own expense.

USER-INSTALLER

CAUTION: Your authority to operate this FCC verified equipment could be voided if you make changes or modifications not expressly approved by the party responsible for compliance to Part of the FCC Rules.

HANDLING PRECAUTIONS

- Do not use any AC adapter other than the one supplied with the product.
- This Camera has no power switch. Before maintenance, disconnect the power plug from the outlet.
- This Camera is designed only for use indoors. Do not use this Camera out of doors.
- Do not leave the Camera under direct sunlight or by heater, or the Camera may be discolored, or damaged.
- Do not place the Camera in any humid, dusty, windy or vibrating location. Use the Camera in the following environmental condition:
 - Temperature: (Recommended) -10°C to 40°C
 - (Working) -10°C to 50°C
 - Humidity: 30% ~ 90% (Non condensing)
- Use a soft, dry cloth for cleaning. Do not use any volatile solvent, such as thinner or benzin.
- Do not directly point the camera lens into the sun, or the camera may be damaged.
- This Camera is designed only for installation to the ceiling.

When installing this Camera, use only the dedicated fixing plate, refer to the pages 11 to 15 of this manual, and carefully check the safety, such as falling prevention.
- Exclusions
 - We will not be liable for any damage arising out of or resulting from acts of God (including earthquakes, floods, and lightning), fires, accidents, conducts or other accidents by third parties, or your misuse, whether intentional or unintentional, or use of the product under undesired conditions.
 - We will not be liable for any incidental damage to the use of the product (including loss of business profit, interruption of business, and change or loss of records).
 - We will not be liable for any damage arising out of or resulting from failure to observe the instructions stated in the operation manual for the product.

- We will not be liable for any damage arising out of or resulting from malfunction or hung-up of the product due to the use of an appliance or software we are not involved in for the product.
- We will not be liable for any damage arising out of or resulting from repairs or tampering of the product by yourself or any unauthorized third party.
- Our monetary liability shall not exceed the unit price of the product in any case within the scope provided by laws.

■ Precautions about copyrights and rights of portraits

Please keep the following in mind:

- You may infringe the copyrights, rights of portraits or any other rights to images you record using the product if you use such images in any way (including distribution, disclosure, and exhibition thereof) without the right holders' prior consent.
- The filming of demonstrations, performances, exhibits, etc. may be restricted even for the purpose of monitoring.
- All copyrighted images and data may be used within the scope permitted by the Copyright Law.

■ Precautions about the replacement of the battery for the wireless remote controller:

- If the Camera is not used for long time, take out the batteries from the case.
- Do not use rechargeable Ni-Cd batteries.
- Do not use new and old batteries, or batteries of different type together.
- Do not try to recharge or short-circuit the batteries.

■ Longevity of parts

- The product uses some life-limited parts that must be replaced periodically (aluminum electrolytic capacitor, backup battery, etc.).
- The service life of each part depends on the working environment or conditions, and we recommend that you periodical inspections be performed. Before performing inspections, consult the shop or our nearby branch or sales office.

CONTENTS

IMPORTANT SAFETY INSTRUCTIONS	1
HANDLING PRECAUTIONS	3
CONTENTS	5
1. PART NAMES AND FUNCTIONS	7
2. WIRELESS REMOTE CONTROLLER	9
3. SETTING UP	11
[1] Installation	11
[2] Drawing the Composite Cable from the Camera Back Face	14
4. OPERATION PROCEDURES	16
[1] Power ON/OFF	16
[2] Turning ON/OFF of the Camera power	16
[3] PAN/TILT operation	17
[4] Lens operation	17
[5] Preset operation	19
5. THE ID NUMBER (REMOTE ID) SETTING	20
6. SETTING IN THE OSD (ON-SCREEN DISPLAY) MENU	21
7. Alarm	29
8. RS-485	30
[1] Setting the terminating resistance	30
[2] Setting the ID address	30
9. SOUND	31
10. SETTING OF VARIOUS MODES	32
[1] Initializing the settings	32
[2] Setting the RS-485 terminal resistor	32
11. NETWORK FUNCTION	33
[1] Preparations for connection	33
[2] Install	36
[3] Web browser	37
(1) Restrictions	37
(2) Connection	38
(3) Live display	41
(4) Capture display	43
(5) Settings	44
(6) External GPIO Setup	45
(7) MPEG4 Setup	46
(8) JPEG Setup	47
(9) Network Setup	48
(10) Alarm Setup	50
(11) E-mail Setup	51

(12) FTP Setup	52
(13) User Setup	54
(14) IP filtering Setup	56
(15) Camera Control Setup	57
(16) Camera Settings	58
(17) Camera Settings (AE Settings)	58
(18) Camera Settings (Picture Settings)	60
(19) Camera Settings (Misc. Settings)	63
(20) System Time Setup	64
[4] MPEG4 Viewer software [ELMO 1Channel Viewer]	65
(1) Restrictions	65
(2) Connection	65
(3) Live display	67
(4) Sound	69
(5) Settings	70
(6) MPEG4 Setup	71
(7) JPEG Setup	72
(8) Network Setup	73
(9) Alarm Setup	75
(10) E-mail Setup	76
(11) FTP Setup	77
(12) Motion Detection Setup	79
(13) User Setup	80
(14) IP filtering Setup	82
(15) Snapshot Setup	83
(16) Color Setup	83
(17) Camera Control Setup	84
(18) External GPIO Setup	84
(19) Camera Settings (AE Settings)	85
(20) Camera Settings (Picture Settings)	85
(21) Camera Settings (Misc. Settings)	86
(22) System Time Setup	86
(23) Tools	87
(24) Firmware update	88
[5] Set items	90
12. TROUBLESHOOTING HINTS	100
13. SPECIFICATIONS	104
14. SUPPLIED ACCESSORIES.....	108
15. OPTIONS	119

1. PART NAMES AND FUNCTIONS

● Main unit

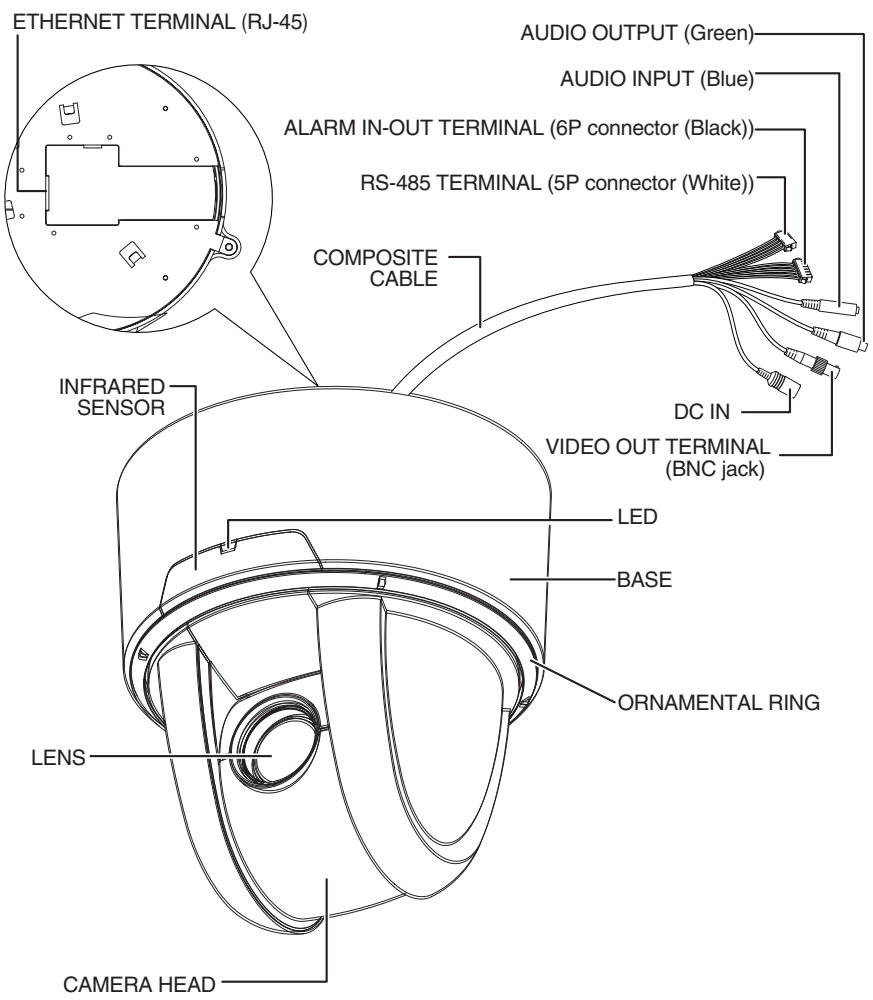

● Wireless Remote Controller

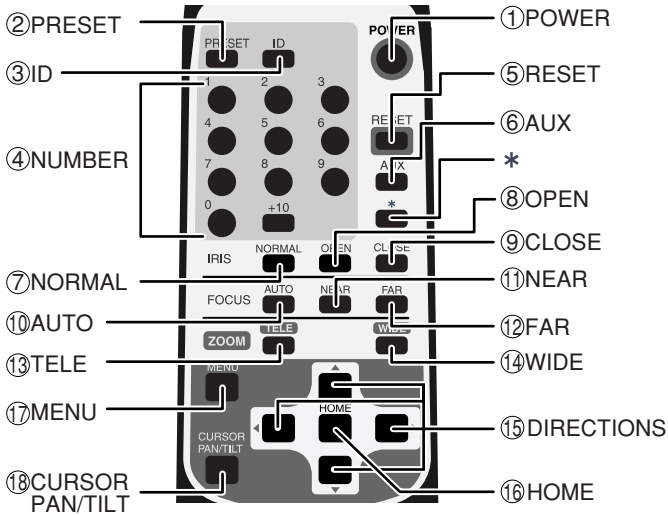

Note: The "*" and "AUX" buttons are not used for normal operation.

Button Name	Function	Ref. Page	
① POWER	To turn ON/OFF the Camera power.	P.16	
② PRESET	To register the preset position.	P.19	
③ ID	To set the ID No. when multiple Cameras are used.	P.20	
④ NUMBER	To move and register the preset position and set the ID No.	P.19	
⑤ RESET	To readjust the position of the Camera head.	P.17	
⑥ AUX	Not available.	-	
⑦ IRIS	NORMAL	To return the iris to the factory setting automatically.	P.18
	OPEN	To open the iris.	P.18
	CLOSE	To close the iris.	P.18
⑩ FOCUS	AUTO	To adjust the focal point automatically to maintain it in the "in focus" status.	P.18
	NEAR	To move the focal point near.	P.18
	FAR	To move the focal point far.	P.18
⑬ ZOOM	TELE	To zoom in (TELE) the image.	P.17
	WIDE	To zoom in (WIDE) the image.	P.17
⑮ DIRECTIONS	To change the Camera head direction by operating the cursor on the OSD.	P.17, 21	
⑯ HOME	To move the Camera head direction by operating the cursor on the OSD.	P.17, 21	
⑰ MENU	To turn ON/OFF the OSD display. In the hierarchical menu, the screen immediately before appears.	P.20, 21	
⑱ CURSOR PAN/TILT	To suspend the menu operation.	P.21	

2. WIRELESS REMOTE CONTROLLER

Point the infrared emitter of the wireless remote controller to the infrared sensor located on the front of the Camera main unit, and press the button of the intended operation.

For the receivable range, refer to the below figures.

● Receivable range

Distance : Within approx. 7m from the infrared sensor front

Angle : Within approx. 60° right and left, approx. 10° above and approx 30° below from the infrared sensor front

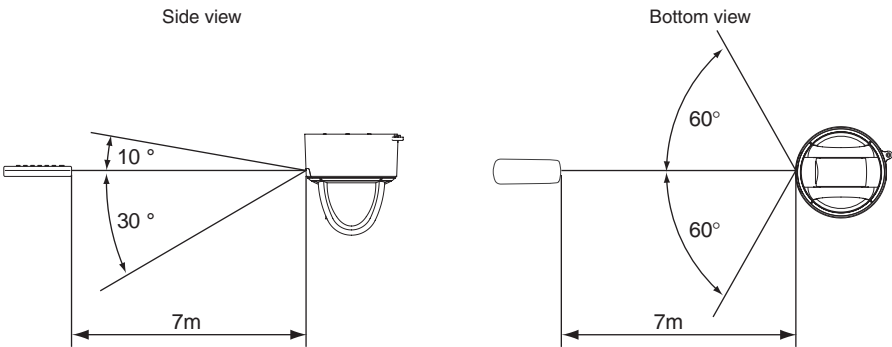

Note: The infrared sensors may receive the infrared rays only within a narrower receivable range or may not receive them at all depending on the ambient environment, such as being placed under the sunlight or near an inverter fluorescent lamp. In such case, relocate the installation place of the receiving side or block off the sunlight.

● Precaution for the battery

Remove the battery case cover by pressing downward on the [▼] mark part in the direction as indicated by the arrow.

Install 2 pcs. of batteries (type R03,AAA) into the case in the direction as indicated there.

Note: Install the batteries with the proper ⊕ to ⊕ and ⊖ to ⊖ polarity.

Note: For dry cells, be sure to use the size AAA.

Note: Change the batteries at least once a year or when even necessary.

Note: The batteries supplied with the Camera are only for use in initially confirming the operation of the Camera.

It is not guaranteed that these batteries will work effectively for the indicated period.

- When multiple Cameras are operated through the wireless remote controller

Refer to "5. THE ID NUMBER SETTING" on P. 20.

3. SETTING UP

[1] Installation

Note: When carrying the Camera, be sure to hold the base.

Note: Do not turn the Camera head in the PAN-TILT direction by hand, or the Camera head could be broken.

(1) Mounting the Fixing Plate

1. Make mounting holes and a cord hole in the place (ceiling) to which this Camera is installed.

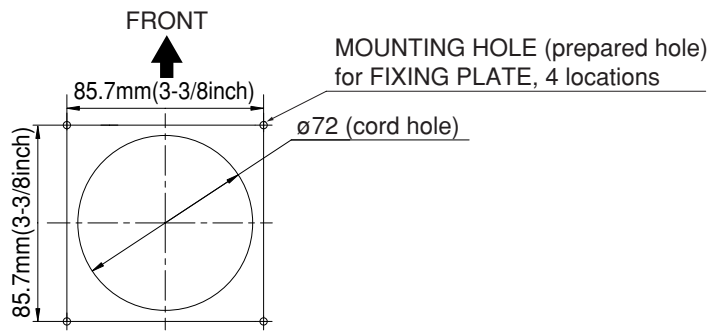

WARNING: The total mass of the main unit and fixing plate is approx. 1,200g. Check whether the ceiling to which the Camera is installed is strong enough to hold the total mass of the main unit and fixing plate. If not, the Camera could fall, causing injury.

2. Lock the fixing plate (supplied) firmly with 4 fixing screws (supplied).

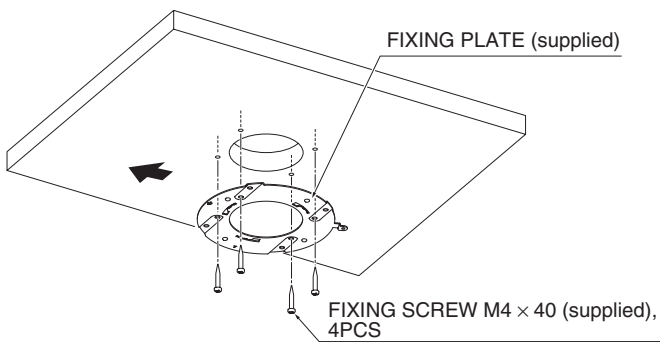

WARNING:Fasten the fixing screws of the fixing plate firmly, or the Camera could fall, causing injury.

(2) Mounting the Camera to the Fixing Plate

- 1.Match the [Δ] mark on the fixing plate with the [Δ] mark on the back face of the main unit, set the tabs (3 locations) of the back face of the main unit in the mating cuts (3 locations) of the fixing plate, and turn the main unit clockwise by 25° (Refer to A)

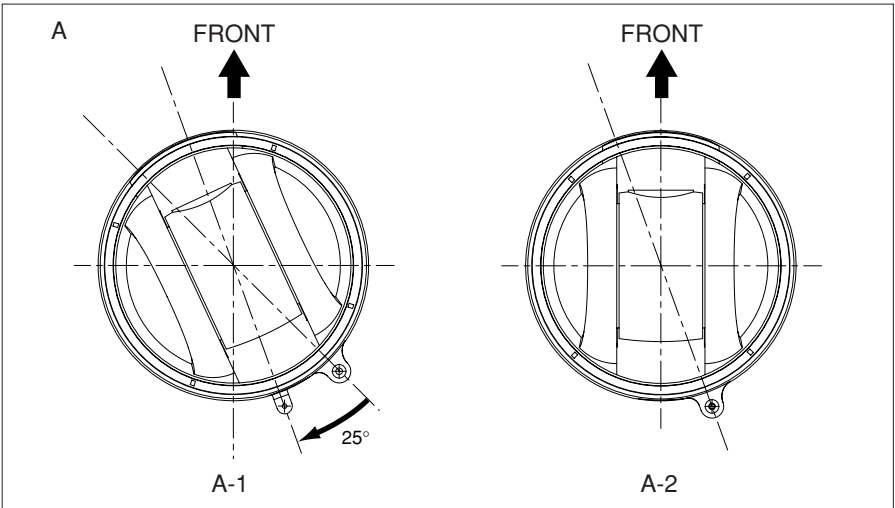
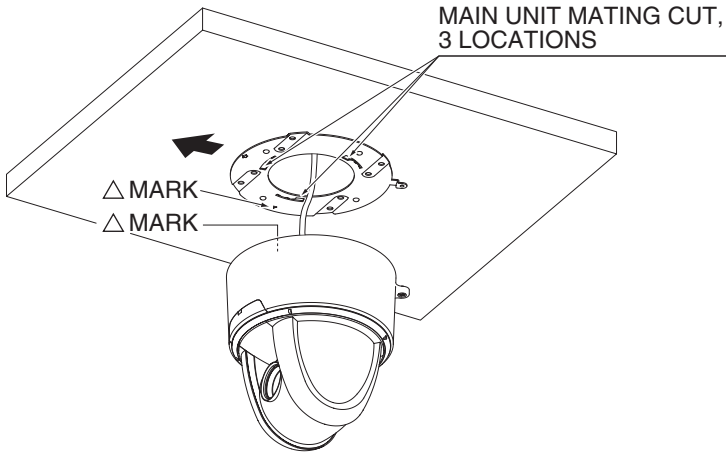

(3) Mounting the Safety Wires

1. Loop up one end of the Safety Wires through the respective safety wire looping holes made on the Ceiling Plate, and then loop up the other end of the same around the beams or anything that is used to mount ceiling tile channel for structure safety.

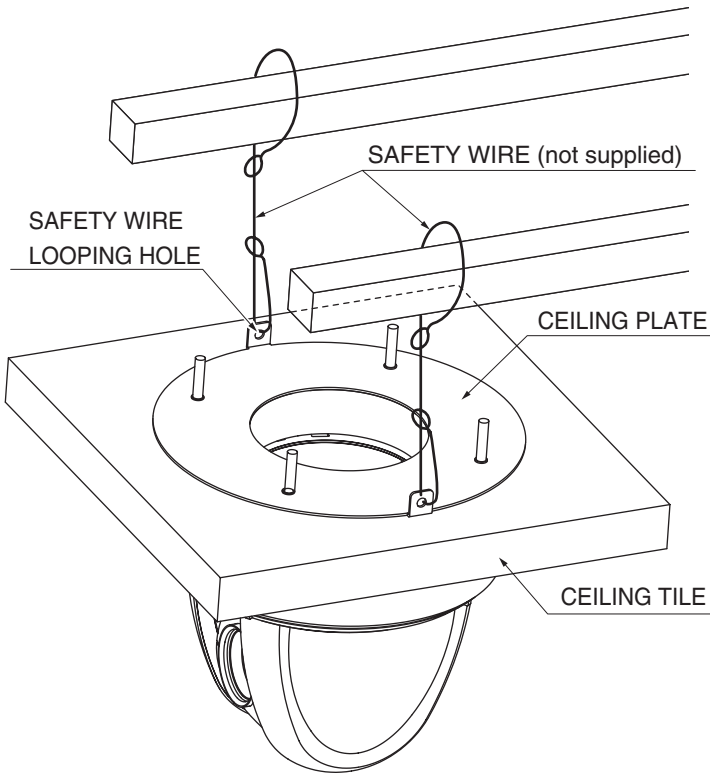

2.Lock the Camera and the fixing plate with the set screws (supplied).

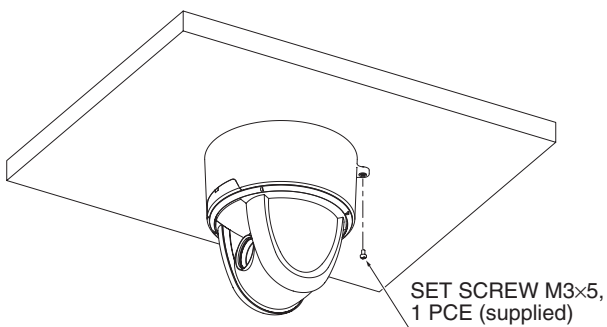

[2] Drawing the Composite Cable from the Camera Back Face

(1) Cut off the blank cover from the back face of the Camera base with pliers or the like, and draw the composite cable from the back face of the Camera.

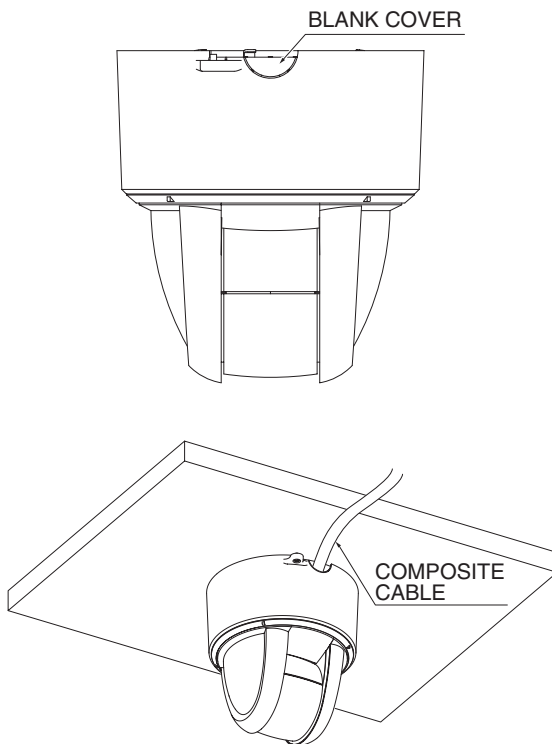

● Connection of the Camera

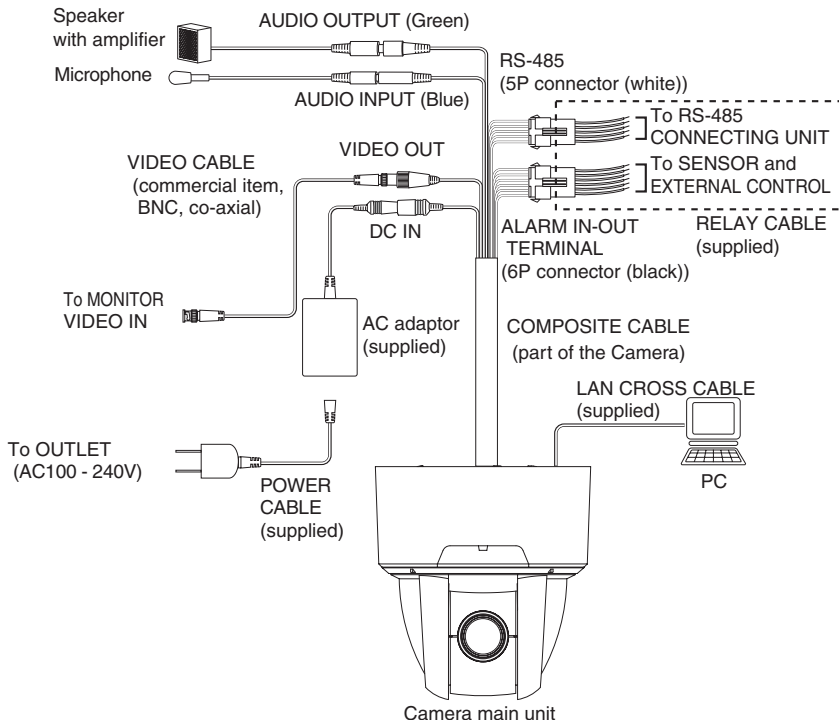

RS-485 terminal
(5P connector (white))

Pin No.	Terminal Name	Cord Color
①	DATA (+) IN	Brown
②	DATA (-) IN	Red
③	DATA (+) OUT	Orange
④	DATA (-) OUT	Yellow
⑤	GND	Green

ALARM IN-OUT terminal
(6P connector (black))

Pin No.	Terminal Name	Cord Color
①	ALARM IN1	Blue
②	GND	Purple
③	ALARM IN2	Gray
④	GND	White
⑤	ALARM OUT	Black
⑥	General-purpose output	Pink

Note: When wiring, note the following:

- For the RS-485 ALARM IN-OUT cable, insulate the bare conductor part not to be exposed after wiring.
- For the video cable, keep the BNC connector (metal part) away from any other metal material.

4. OPERATION PROCEDURES

[1] Power ON/OFF

The Camera has no POWER switch. The power supply to the Camera is turned ON when the power cord and AC adapter are connected to the outlet and the Camera.

Once the Camera is turned ON, it automatically starts initial setting.

[2] Turning ON/OFF of the Camera power

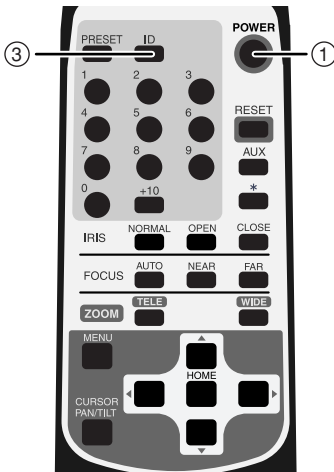

(1) Turning OFF the Camera

- When the Camera is ready for operation through the wireless remote controller and ① **POWER** button is pressed, the Camera power is turned OFF. (However, even after the Camera is turned OFF, power is still being supplied to the Camera as power supply to the Camera is not OFF.)
- The image disappears, and the LED on the Camera lights up in red. Now, no buttons on the wireless remote controller are functional other than ① **POWER** button and ③ **ID** button.
- When the OFF TIME function is ON (refer to the settings in the OSD (On-Screen Display) Menu screen on P.22), Camera power is turned OFF automatically upon the lapse of the set time.

(2) Turning ON the Camera

- When the Camera is OFF and ① **POWER** button is pressed, the Camera power is turned ON.
- The image appears, and the LED on the Camera goes out. Now, the Camera is ready for operation of all functions through the wireless remote controller.
- If the ID number is changed, the Camera power may not be turned ON. In such case, redo the ID number setting, and press ① **POWER** button.

[3] PAN/TILT operation

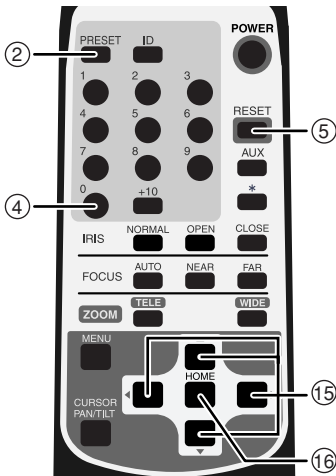

- While watching the screen, press any of ⑮ (UP, DOWN, LEFT, RIGHT) direction buttons for the desired direction in which you want to watch the image.
- To change the direction minutely, jog the direction button. To change the direction largely, hold down the direction button.
- Two operation modes are available according to the speed: AUTO mode changing the speed according to the zoom position, and MANUAL mode setting the speed manually. (Refer to the settings in the OSD (On-Screen Display) Menu screen on P.27)

- When ⑯ **HOME** button is pressed, the Camera turns to the front (and the lens moves to the WIDE end) according to the factory settings. The home position can be set freely with the preset No. "0." (Press ② **PRESET** button and then press ④ **0** button.) After setting, when ④ **0** button or ⑯ **HOME** button is pressed, the home position is called in. (Refer to P. 19)
- If the Camera direction is changed manually by mistake, press ⑤ **RESET** button. Then, the Camera remembers the last PAN/TILT position in memory.

[4] Lens operation

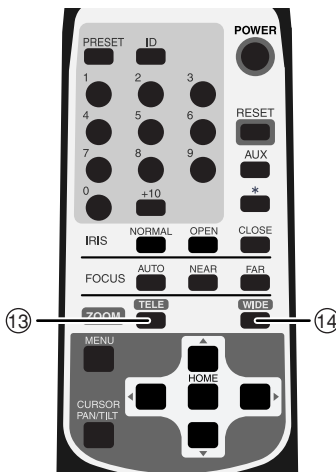

(1) Zoom operation

- The object is zoomed in (appears larger in the screen) when ⑬ **TELE** button of ZOOM is pressed, or zoomed out (appears smaller in the screen) when ⑭ **WIDE** button of ZOOM is pressed.
- When ⑬ **TELE** button or ⑭ **WIDE** button is held down for over one second, the zoom speed increases.

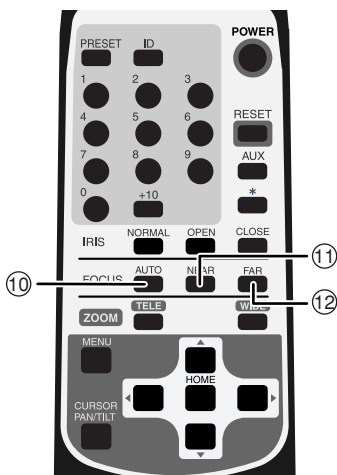

(2) Focus operation

- When ⑩ **AUTO** button of FOCUS is pressed, the FULL AUTO FOCUS status is established. However, focusing may be difficult for such objects as listed below.
 - Objects with no contrast between light and shade, such as white walls and night views
 - Objects reflecting an intensive light
 - Objects moving fast
 - Objects with many horizontal stripes, such as blinds
 - Objects viewed through a glass pane with water drops or stains
 - Objects with vertical fine stripes
- To adjust the focus manually, press ⑪ **NEAR** button or ⑫ **FAR** button.

When ⑪ **NEAR** button is pressed, the focus shifts near to you.

When ⑫ **FAR** button is pressed, the focus shifts far away from you.

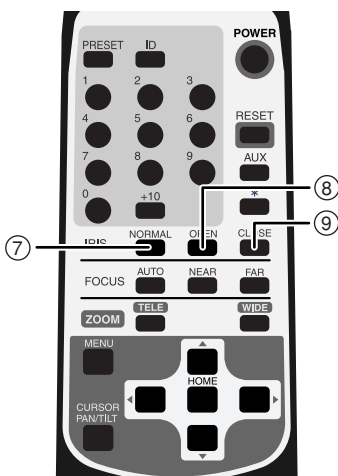

(3) Iris

- The iris remains in the AUTO IRIS status (in the Auto Control mode in which the brightness remains unchanged even if the object is changed).
- When ⑧ **OPEN** button or ⑨ **CLOSE** button of the iris is pressed, the brightness changes in the AUTO IRIS status. (The reference level of the AUTO IRIS changes.)
- ⑧ **OPEN** button or ⑨ **CLOSE** button cannot be held down. To operate the iris continuously, repeat pressing and releasing the button.
- When ⑦ **NORMAL** button is pressed (in the AUTO IRIS state), the brightness is reset to the standard level.

[5] Preset operation

The Camera head direction, the zoom position, the focus status and the brightness level can be registered. In addition to these items, when [MAIN CONTROL] – [CAMERA2 PRESET] is set to [ON] in the OSD menu, the [CAMERA2] settings can also be registered together (Refer to P. 24). Up to 17 setting can be registered (Nos. 0 – 16). Even if the main unit power is turned OFF, the registered contents are preserved.

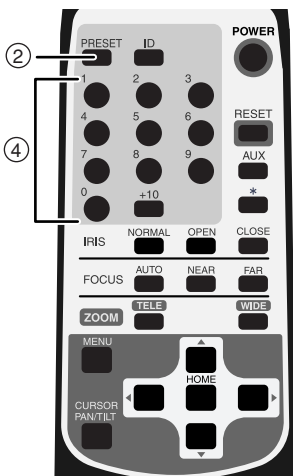

(1) Registration in the Preset Contents

- Set the Camera head direction, the zoom position, the focus status and the brightness level. (To register the [CAMERA2] settings together, set [MAIN CONTROL] – [CAMERA2 PRESET] to [ON] in the OSD menu.)
- When ② **PRESET** button is pressed (once), the LED (light emitting diode) on the main unit blinks in green (at intervals of 0.2 sec). To cancel this step, press ② **PRESET** button again.
- Then, input the preset No. within 0 through 16 by pressing ④ corresponding one or two of the **0** through **+10** buttons. (**+10** button is used to input numeric of 10 or larger. For “10,” press **+10** button and then **0** button.)
- Upon pressing, the LED on the main unit goes out and the registration of the preset contents is completed. (The preset contents already registered, if any, are overwritten.)
- The home position can be registered freely to any position by using the preset No. “0.”

(2) Execution of the Preset

- When ④ intended one or two of the **0** through **+10** buttons is pressed, the Camera head direction, the zoom position, the focus status and the brightness level are set as per registered. (**+10** button is used to input numeric of 10 or larger. For “10,” press **+10** button and then **0** button.)

5. THE ID NUMBER (REMOTE ID) SETTING

When multiple Cameras are laid out adjacently and operated via the wireless remote controller, the Cameras receiving the infrared rays operates in unison in the same way. When each Camera is allocated with a different ID No., the Camera can be operated selectively when its ID No. is specified via the wireless remote controller. The ID Nos. can be allocated to up to 9 Cameras.

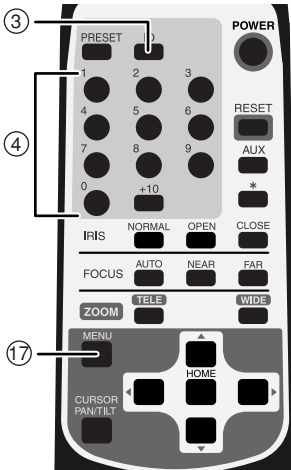

(1) Setting an ID No.

- Turn ON only the camera to be set with an ID No. Turn OFF the other adjacent Cameras. (Unplug from the outlet.)
- Set the remote ID No. to the Camera. (See "6. OSD (On-Screen Display) on P.22) After setting, close the Menu screen by pressing ⑰ MENU button. Then, repeat the ID No. setting for all other Cameras in the same way.

(2) Operating the Cameras selectively

- Press ③ ID button, and the LED's of all adjacent Cameras will start blinking (at intervals of 0.4 sec). To cancel this, press ③ ID button again. Then, press ④ 1 through ⑨ buttons, and the LED's will go out, and selective operation by specifying the ID No. will be ready. Now, only the selected Camera can be operated via the wireless remote controller.

(3) Canceling the specific ID of the Cameras

- Hold down ③ ID button for over 2 sec, and the blinking LED on the Camera will light up. Then, unhand ③ ID button. Now, the selective operation has been cancelled, and all adjacent Cameras start operation via the wireless remote controller.
- Even if the Camera is rebooted, the selective operation by specifying the ID No. is cancelled.

6. SETTING IN THE OSD (ON-SCREEN DISPLAY) MENU

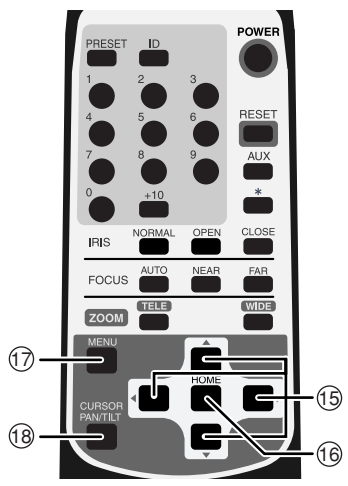

Each time ⑰ **MENU** button is pressed, the OSD menu is turned ON/OFF. In the hierarchical menu, when ⑰ **MENU** button is pressed, the screen immediately before appears.

In the OSD menu, ⑮ **▲ ▼ ◀ ▶** buttons and ⑯ **HOME** button are used for menu operation. To suspend the menu operation and perform the PAN-TILT operation, press ⑱ **CURSOR/PAN-TILT** button.

To resume the menu operation, press ⑱ **CURSOR/PAN-TILT** button again.







● OSD menu





















[1] MAIN CONTROL			
Name	Function	Factory Settings	
1	TITLE	To turn ON/OFF the character display in the bottom of the screen.	OFF
	SELECT	To select the title [CAMERA/PRESET] to be character-displayed (enabled only when the above [TITLE] is ON). [PRESET]: Preset position names 1 – 16 [CAMERA]: Name of camera.	CAMERA

[1] MAIN CONTROL			
Name		Function	Factory Settings
2	SET INDICATE	To turn ON/OFF the screen display of the preset position upon its registration. The No. of the registered preset position is screen-displayed for seconds.	OFF
3	REMOTE ID	To set the ID No. [1 – 9] for the Camera main unit for selective operation by using the wireless remote controller. When the ID No. is not to be set, input [0]. Up to 9 Cameras can be controlled selectively with one wireless remote controller.	0
4	OFF TIME	To set the time of the Low Power Consumption mode [OFF, 40min, 1h, 2h, 3h, 4h, 5h]. If it has passed over this set time with no operation, the Camera power will be turned OFF automatically. (When ① [POWER] button is pressed again, the Camera power is turned ON again.)	OFF
5	AUTO RETURN	To set the time of automatic return to the home position [OFF, 30s, 1min, 2min, 5min, 10min, 20min, 30min] If it has passed over this set time with no operation after the PAN-TILT-ZOOM operation, the Camera will return automatically to the home position. The home position can be registered freely with the preset No. "0."	OFF
6	CAMERA2 PRESET	When this function is set to [ON], the setting of each item of [CAMERA2] can be registered in its preset position. (Set this button to [ON/OFF].)	OFF
[2] CAMERA1			
Name		Function	Factory Settings
1	E-ZOOM MAX	To set the maximum magnification [OFF, 1.5×, 2×, 2.5×, 3×, 4×, 6×, 8×, 16×]. When ⑬ [TELE] button on the wireless remote controller is held down, the optical zoom 12× enters automatically from its end point into the digital zoom zone.	OFF

[2] CAMERA1			
	Name	Function	Factory Settings
2	HS-SHUTTER	To select the high-speed shutter speed [OFF (1/60s), 1/100s, 1/250s, 1/500s, 1/1000s, 1/2000s, 1/4000s, 1/10000s, 1/20000s, 1/50000s]. When [LS-SHUTTER] is [ON], the shutter speed can be selected from [1/60s 1/100s]. If the shimmer of fluorescent lamp is annoying when the shutter speed is set to [OFF (1/60s)], set the shutter speed to [1/100s], and the shimmer will be eased.	OFF
3	LS-SHUTTER	To set the low-speed shutter (electronic sensitivity up) to [ON/OFF]. When the object becomes dark, this function automatically varies the CCD accumulated time across several fields up to the set maximum level to optimize the brightness of the object.	OFF
	LS-MAX	To set the maximum number of fields of the low-speed shutter [2fields, 3fields, 4fields, 5fields, 6fields, 8fields, 12fields, 20fields, 40fields, 80fields]. If the CCD accumulated time is set longer, the frame rate will decrease, and moving object could not be seen well.	4fields
	PRIORITY	To select the image attributes [MOTION, COLOR, S/N (fineness)] to be prioritized when [LS-SHUTTER] is selected and the object becomes dark.	MOTION
4	ICR	To set the DAY/NIGHT function (IR cut filter removable function). When this function is set to [AUTO], the filter is attached/removed automatically according to the brightness. When the IR cut filter is removed, the color image is switched to B&W image.	OFF
5	AUTO LEVEL	To select the timing of switching from B&W to color [1 – 15]. Particularly when the infrared illumination is intensive, select larger numeric value to prevent hunting.	5
6	INFRARED	To set the infrared illumination using mode to [ON/OFF]. To use the infrared illumination, set this function to [ON]. If the infrared illumination is used with this function in the [OFF] status, the image could be out of focus.	OFF
7	AGC GAIN	To set the maximum gain of the AGC [0dB, 4dB, 8dB, 16dB, 20dB, 24dB]. The AGC is a function of amplifying the signal from the CCD to make the object visible when the object becomes dark.	8dB

[3] CAMERA2												
	Name	Function	Factory Settings									
1	BLC	To set the backlight compensation function to [ON/OFF]. When there is an intensive light in the background, this function prevents the object from becoming dark.	OFF									
	BLC MODE	To select the Backlight Compensation Setting mode [AREA/HIST].	AREA									
	About the Backlight Compensation Setting mode											
	AREA	To select the image area of the object that needs an appropriate brightness and weighing according to the selected area.										
	HIST	To make the dark (blackened) part of the image visible regardless of the area.										
AREA	To select the area [0 – 4] on the image where the backlight compensation function works when [AREA] is selected.	4										
		<table border="1" style="margin: auto;"> <tr> <td colspan="3">AREA0</td> </tr> <tr> <td>AREA3</td> <td>AREA4</td> <td>AREA2</td> </tr> <tr> <td colspan="3">AREA1</td> </tr> </table>	AREA0			AREA3	AREA4	AREA2	AREA1			
AREA0												
AREA3	AREA4	AREA2										
AREA1												
2	AP GAIN	To select the detail compensation level [-5~10]	±0									
3	WB	To select the White Balance Setting mode [ATW, AWC, INDOOR, OUTDOOR, FL-LIGHT, MWB].	ATW									
	About the White Balance Setting mode											
	ATW	To adjust the white balance by way of continuous, automatic following. (When the image is in a single color all over, the white balance may not be adjusted correctly.)										
	AWC	To adjust the white balance by one-push of button. When [AWC] is selected and  [HOME] button is pressed, the white balance is adjusted automatically in the then screen status. (This adjustment ends in seconds, and the adjusted value is fixed.)										

[3] CAMERA2			
Name		Function	Factory Settings
	INDOOR	This function is selected when the Camera is used indoors. The color temperature is assumed to be 3200K.	
	OUTDOOR	This function is selected when the Camera is used outdoors. The color temperature is assumed to be 6300K.	
	FL-LIGHT	This function is selected when the Camera is used under the fluorescent illumination. The color temperature is assumed to be 4200K.	
	MWB	To change the color tendency as desired.	
	MWB-R	To set the red color tendency [-30~+30] when [MWB] is selected.	±0
	MWB-B	To set the blue color tendency [-30~+30] when [MWB] is selected.	±0
[4] MASKING			
Name		Function	Factory Settings
1	MASK	To select [ON/OFF] of the masking function. When there is any part to be masked in the image to be captured, this function masks such part. (However, during the PAN-TILT-ZOOM operation, mask is not displayed.) After setting the area data, even if [OFF] is selected and the mask display disappears, the area data will not be cleared.	OFF
	AREA1-6	To select [ON/OFF] of the masking for 6 areas, individually, when [ON] is selected in [MASK]. When the area to be set is selected from [AREA1 – 6] and  [HOME] button is pressed, the Detail Set window for the selected area appears.	
	About the detail setting of [AREA1 – 6]		
	SIZE	To set the mask size, display the [SIZE] Set window, move the size by using     buttons, and then press  [HOME] button.	

[4] MASKING			
Name		Function	Factory Settings
	LOCATION	To set the mask position, display the [LOCATION] Set window, move the position by using $\textcircled{15}$     buttons, and then press $\textcircled{16}$  button.	
	SAVE	When the cursor is moved to [SAVE] and $\textcircled{16}$  button is pressed, the mask data (position, size) is saved and enabled. However, when the rotating angle of TILT is 45° – 135° ($\pm 45^\circ$ from the beneath-facing status of the Camera), the mask data cannot be saved.	
	CANCEL	When the cursor is moved to [CANCEL] and $\textcircled{16}$  button is pressed, the unsaved mask is disabled, and the image returns to the status before the mask setting.	
	CLEAR	When the cursor is moved to [CLEAR] and $\textcircled{16}$  button is pressed, the mask in display disappears, and the image falls into the status without the mask setting.	
[Note] The masking function is not complete since it may make a part to be masked visible depending on the zoom position or Camera direction. Therefore, do not try to mask any confidential information by using this function.			
[5] TITLE SET			
Name		Function	Factory Settings
1	CAMERA	To register the Camera main unit name. This function is convenient when multiple Cameras are used. Move the cursor to [CAMERA] to make the cursor blink. Go to the character to be set by using the  button. Change the character by using the   buttons, and move from character to character by using the   buttons. By setting the characters one by one, up to 10 characters can be set. After setting, press $\textcircled{16}$  button for saving.	CAMERA -1
2	PRESET1-16 HOME	To register all preset position names selectively. Move the cursor to [PRESET1 – 16] to make the cursor blink. Go to the character to be set by using the  button. Change the character by using the   buttons, and move from character to character by using the   buttons. By setting the characters one by one, up to 10 characters can be set. After setting, press $\textcircled{16}$  button for saving.	PRESET -1-16, HOME

[6] PAN TILT			
Name		Function	Factory Settings
1	MOTOR SPEED	To select the motor speed setting [AUTO/MANUAL] for the PAN-TILT operation. When [AUTO] is selected, the operation speed varies automatically according to the zoom position. When [MANUAL] is selected, the operation speed can be selected freely.	AUTO
	SPEED	To select the operation speed [0 – 7] (0: Fastest) when [MOTOR SPEED] is set to [MANUAL].	0
2	L/R DIRECTION	To change the direction of the PAN operation left and right.	OFF
3	DOME COVER	When the Clear Dome Cover (PTC40CL) or the Smoke Dome Cover (PTC40SM), both available on option, is attached, set this function to [ON]. According to the dome cover, this function limits the TILT operation range. (When the dome cover is not attached, set this function to [OFF].)	OFF
4	PRESET STILL	When this function is set to [ON], the image during the movement between the preset positions becomes static (the image before the movement). In this mode, movement is enabled between the preset positions (including the home position), but the PAN-TILT-ZOOM operation is disabled. This function is useful to mask the images other than the home position image and the preset position images. (However, only when the ⑤ PRESET button is pressed, the image cannot be static.) (Set this function to [ON/OFF].)	OFF

[6] PAN TILT			
Name		Function	Factory Settings
5	FLIP ANGLE	<p>When the rotation angle exceeds 90°(the Camera is facing beneath) for the TILT operation, the image reverses upside down. For example, the ceiling comes to the bottom of the image. In this case, this Camera automatically reverses the image vertically or horizontally.</p> <p>To select the image reverse angle [OFF, 100°, 110°, 120°, 130°, 140°]</p> <p>(When the image should not be reserved, set this</p>	120
[7] ALARM			
Name		Function	Factory Settings
1	ALARM IN1	To set the preset position [PRESET1 – 16] for movement in case of input in the ALARM IN terminal <1>	PRESET1
	ALRAM LOCK	When this function is set to [ON], as long as the input is in the ALARM IN terminal <1>, other operations are disabled. (Set this function to [ON/OFF].)	OFF
2	ALARM IN2	To set the preset position [PRESET1 – 16] for movement in case of input in the ALARM IN terminal <2>.	PRESET2

7. Alarm

Alarms are caused by “alarm 1,” “alarm 2,” and “motion detection.”

You can set an alarm action for each cause. “Preset,” “With/Without alarm,” “Send e-mail/Send FTP/Both/None” are available.

For alarm input 1, “lock mode,” which disables other operations during input, can be set. (See page 28.)

Note: Another set alarm action takes place. caused by alarm input 1 or 2 takes place after moving to corresponding preset number “1” or “2.”

Note: Since a preset action does not take place when a motion is detected, another set alarm action takes place.

Note: An alarm remains output from the alarm output terminal for ten seconds. The alarm output period is fixed.

Specifications of the alarm output terminal: Open collector output, maximum rating: DC12 V, 30 mA

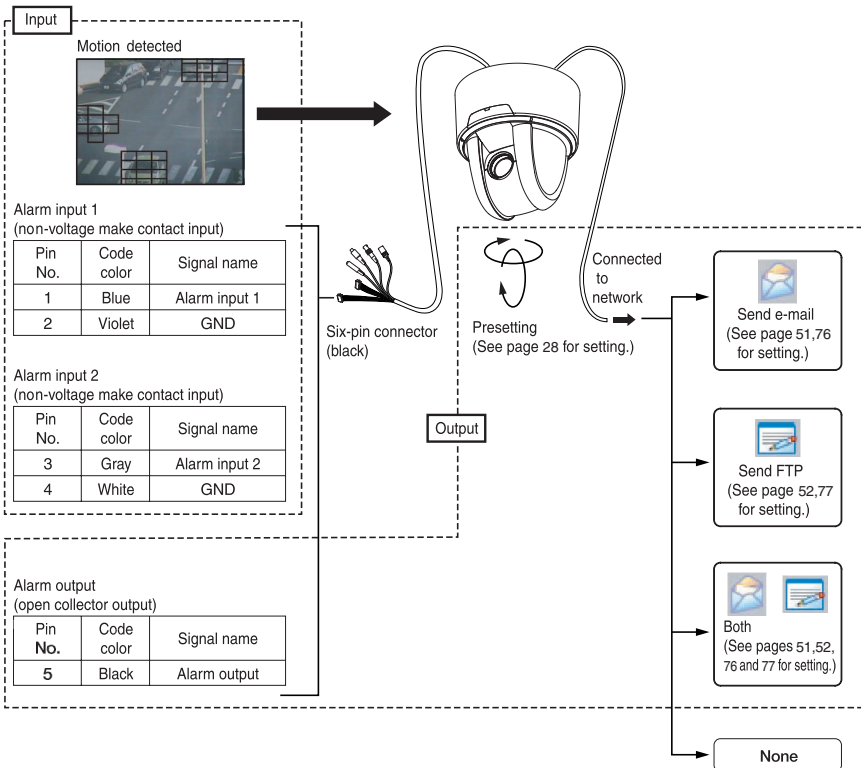

8. RS-485

By wiring and connecting the RS-485 terminal of the 5P connector (white) to an RS-485 control equipment, the Camera can be controlled externally.

By setting the ID address for the RS-485 communication in each Camera, up to 223 Cameras can be controlled by a single PC or a controller.

To assure the reliability, connect DATA(+) and DATA(-) with a shielding twist pair wire. To protect the Camera main unit and the controller, be sure to turn OFF all the equipment before starting connection.

● Transmission specifications

- Transmission mode : Synchronous half duplex
- Transmission speed : 9600bps
- Start bit : 1 bit
- Stop bit : 1 bit
- Parity bit : None

● RS-485 terminal (5P connector (white))

Pin No.	Code Color	Signal Name	Signal Function
①	Brown	DATA(+)	+ side: To input the transmitted/received data
②	Red	DATA(-)	- side: To input the transmitted/received data
③	Orange	DATA(+)	+ side: To output the transmitted/received data
④	Yellow	DATA(-)	- side: To output the transmitted/received data
⑤	Green	GND	GND

[1] Setting the terminating resistance (Refer to P. 32)

For the telecommunication equipment to be connected to the RS-485 interface, a terminating resistance should be attached to both ends of the equipment having the longest route to prevent signal damping.

The terminal resistor will be connected by setting DIP switch No. 3 on the bottom of the Camera to ON.

[2] Setting the ID address (Refer to P. 20, 48, 73)

Set an ID address for RS-485 communication between 1 and 223 based on the settings of “ELMO 1Channel Viewer” or Web browser.

For the information of the data format specifications and command list, please contact our dealer.

9. SOUND

Sound of the microphone connected to the Camera can be output from the speaker connected to a client (PC, etc.) on the network, and sound of the microphone connected to a client can be output from the speaker with amplifier connected to the Camera. For further information about operation, see “Speaker” on page 42 and “(4) Sound” on page 69.

Note: When dedicated software for MPEG4 is used for the connection between a client and the Camera, no sound will be transmitted or received if you select [MPEG4 Setting] – [Frame Rate] (page 46 or 70) and set 1 at “Frame Rate.”

Note: When a Web browser is used for connecting a client to the Camera, sound will not be transmitted from the Camera to the client.

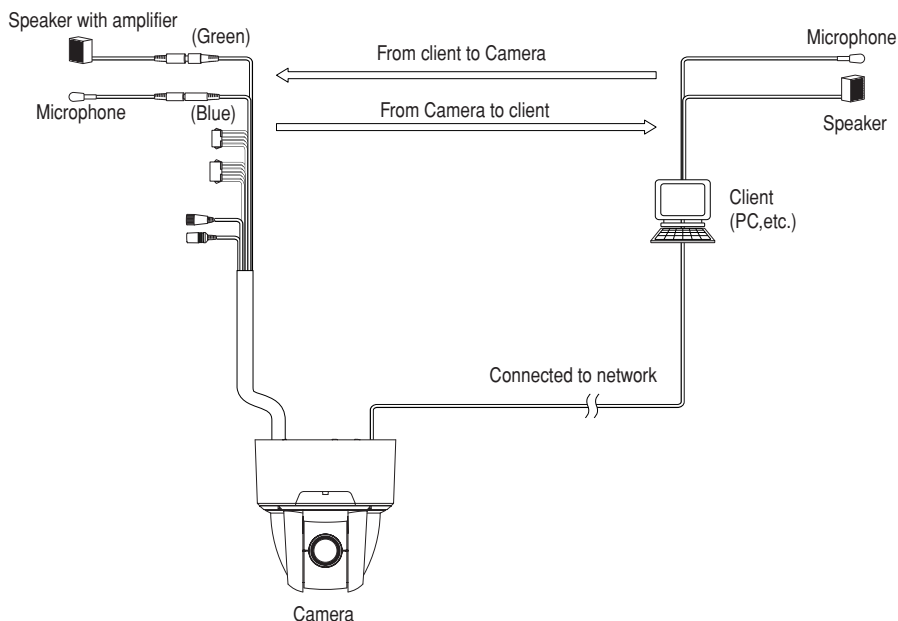

10. SETTING OF VARIOUS MODES

The following mode can be selected by setting 4-pin DIP switches No. 2 to No. 3 on the bottom of the Camera to ON or OFF.

Note: Switch No. 4 is not available. Keep it OFF.

[1] Initializing the settings

Set DIP switch No. 2 to ON to turn ON the power. In ten seconds, all of the PAN-TILT settings, lens settings, preset settings, OSD (on-screen display)-based Camera settings, and network function settings will be reset to the factory settings. After the power is turned OFF, set the DIP switch to OFF.

Note: Set the DIP switch to OFF after initialization. If the power is turned ON with the switch kept ON, all settings will be initialized each time and will not be saved.

[2] Setting the RS-485 terminal resistor

The terminal resistor will be turned ON by setting DIP switch No. 3 to ON or turned OFF by setting it to OFF.

● Pin assignment

Pin No.	Normal	Operation	Function
1	OFF	Leave in OFF	—
2	OFF	ON → OFF	To initialize the settings
3	OFF	ON	RS-485 terminal resistor connection
4	OFF	Leave in OFF	—

● 4-pin DIP switch

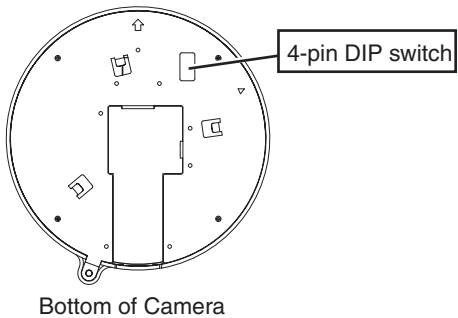
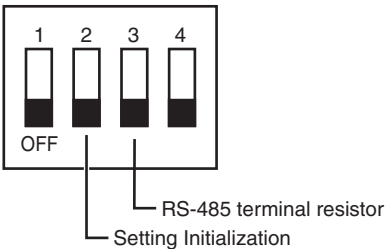

11. NETWORK FUNCTION

You can use the following functions of the Camera from the host (PC) on a network by connecting it to the network via Ethernet (10BASE-T/100BASE-TX):

- Web server function.....For displaying live images and snapshots and remote-operating the Camera on a Web browser.
- MPEG4 server functionFor displaying live images and snapshots and remote-operating the Camera on dedicated client software (ELMO 1 Channel Viewer: hereinafter called “Viewer”),
- Sound server functionFor receiving sound on a Web browser. For receiving or transmitting sound on a Viewer.
- Alarm functionFor saving image files in the server and transmitting e-mail by alarm input.
- IP filtering function.....For restricting hosts permitted to access the Camera.

Note: The Camera is not connectable to some network systems.

Note: Some restrictions may be placed on the host in access to the Camera via a Web browser or Viewer. For further information, see “(1) Restrictions under [3] Web browser” and “(1) Restrictions under [4] MPEG Viewer software ELMO 1Channel Viewer.”

[1] Preparations for connection

Before connecting the Camera to a network, an IP address and other settings relating to the network must be made.

The Camera offers the following two ways to make network settings:

- Accessing the Camera from the host on the network via a Web browser
- Accessing the Camera from the host on the network via Viewer

● Preparations before connection

Before connection, determine an IP address and a subnet mask to be set in the Camera. For the IP address and the subnet mask, contact the administrator of the network you intend to use.

The network settings of the Camera made by the factory are as follows:

IP address: 192.168.1.10

Subnet mask: 255.255.255.0

Note: If the address of the network you are going to use is not 192.168.1.0 or there is a host on the network whose IP address is 192.168.1.10, you cannot connect the Camera to the network and make settings. In this case, it is necessary to configure a network of 192.168.1.0 comprising the Camera and a host for setting it. Prepare a host with an IP address of 192.168.1.X (X: 1 to 254 except 10) and a subnet mask of 255.255.255.0, and connect the Camera to it.

● Connection to the network

• Connection using a hub

Connect the Ethernet terminal (RJ-45) of the Camera and a port of the hub with each other using an Ethernet straight cable (UTP category 5 or more) commercially available. Do not use the MDI port of the hub.

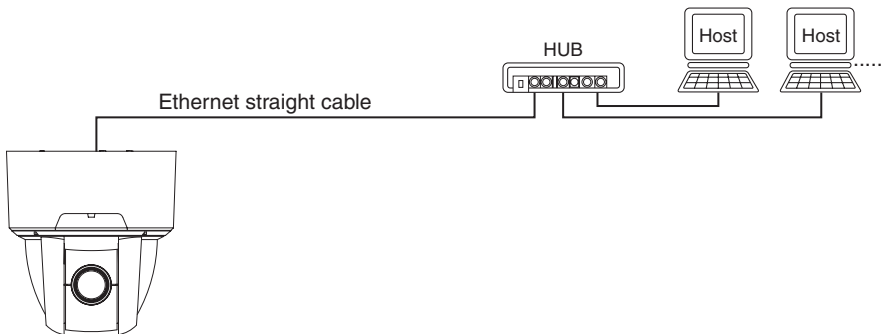

- Connection to a host

Connect the Ethernet terminal (RJ-45) of the Camera and that of the host with each other using the attached Ethernet cross cable or an Ethernet cross cable (UTP category 5 or more) commercially available.

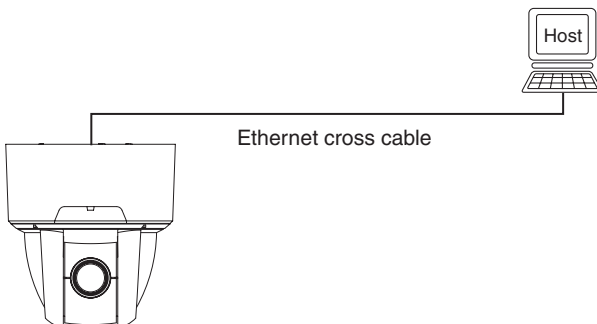

Note: As soon as a network unit is connected to its Ethernet terminal, the Camera automatically adjusts and sets the 10BASE-T/100BASE-TX and half-duplex/full-duplex communication conditions with the connected unit (automatic negotiation).
The Camera does not always guarantee operation with all devices compatible with automatic negotiation.

[2] Install

● Using a Web browser

Access to the Camera via a Web browser requires JRE1.5.0 (Sun Microsystems) or a later version to have been installed and valid.

You can download Java Runtime Environment (JRE) from the company's website. For the installation of JRE, see the website.

● Using Viewer

Access to the Camera via Viewer requires DirectX 9.0C or a later version to have been installed.

DirectX is contained in the Viewer install program on the CD-ROM. Install it according to the instructions of the Viewer Install wizard.

● Installing Viewer

Install Viewer by running the "ELMO 1Channel Viewer install program" on the attached CD-ROM and opening Install Wizard.

As soon as the wizard begins to run, the following screen appears.

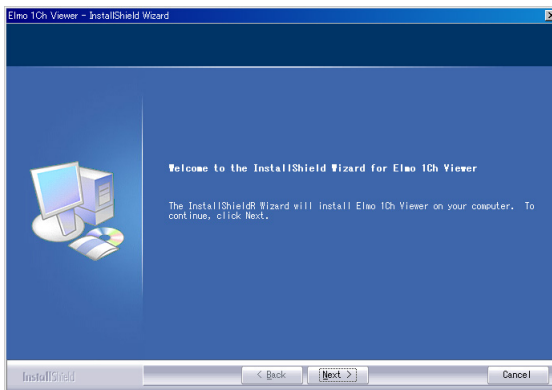

Install the program according to the instructions displayed on Wizard.

Upon completion of installation, an icon for "ELMO 1Channel Viewer" is displayed on the desktop. You can start the Viewer software by clicking on this icon.

● Uninstalling Viewer

Open “Add/Delete Software” on “Control Panel,” select “ELMO IChannel Viewer” from the installed program, and delete it.

On the screen shown below, select “Remove” and press the [Next] button. Viewer will be uninstalled.

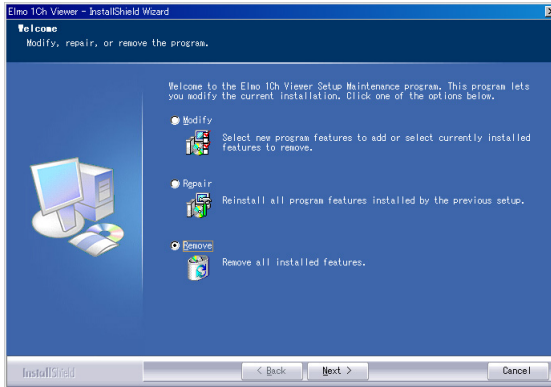

[3] Web browser

(1) Restrictions

Access to the Camera via a Web browser requires the PC to meet the following requirements:

- Microsoft Windows 2000 or XP.
- JRE (Java Runtime Environment) 1.5.0 (Sun Microsystems) or a later version is installed and valid.
- A browser is installed, which properly runs on Microsoft Windows 2000 or XP.

Note: The Camera does not ensure access via some Web browsers.

(2) Connection

Start the Web browser on the host networked to the Camera.

Note: In the example of connection, Microsoft Internet Explorer is used.

1. Enter the IP address of the Camera in the URL input field on the Web browser.
 1. Enter http:// at [Address (D)].
 2. When the IP address or host name of the Camera is assigned, enter the host name, and put “/” at the end.

Example)

Since the IP address of the Camera set by the factory is 192.168.1.10, enter http://192.168.1.10/.

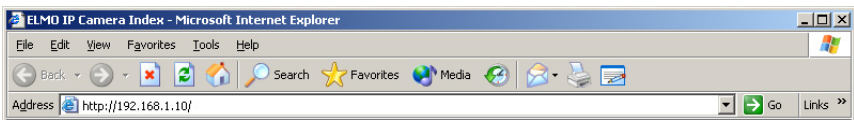

2. You may be requested to enter the ID and password of the Camera depending on the settings for it. Enter them to log in. The administrator login ID and password set by the factory are both “root.”

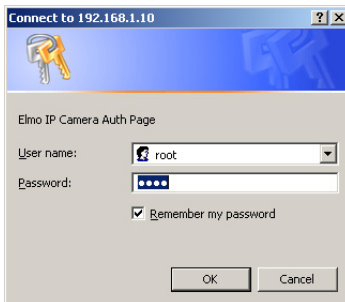

3. The page shown below is displayed on the Web browser.



4. Select English or Japanese.

Note: To display information in Japanese, the browser must be capable of properly displaying Japanese pages.

5. The main page is displayed.



- Home Displays the main page.
- Setup Displays the Setup screen.
- Live View (Half-D1) Displays live images with a size of 704 × 480.
- Live View (SIF) Displays live images with a size of 352 × 240.

- Live View (QQVGA) Displays live images with a size of 160×120 .
- Capture View (Half-D1) Displays capture images with a size of 704×480 .
- Capture View (SIF) Displays capture images with a size of 352×240 .
- Capture View (QQVGA) Displays capture images with a size of 160×120 .

6. For each function, see (3) to (20) that follow.

(3) Live display

Live images taken by the Camera are displayed.

On the main page, select the size of images you want to display live from [Live View (Half-D1)], [Live View (SIF)], and [Live View (QQVGA)].

The sizes of live images are shown below.

- Half-D1 (704 × 240)
- SIF (352 × 240)
- QQVGA (160 × 120)

Note: Half-D1 displays 704 x 240 images in the size of 704 x 480.

Example) Live View (SIF) (352 × 240)

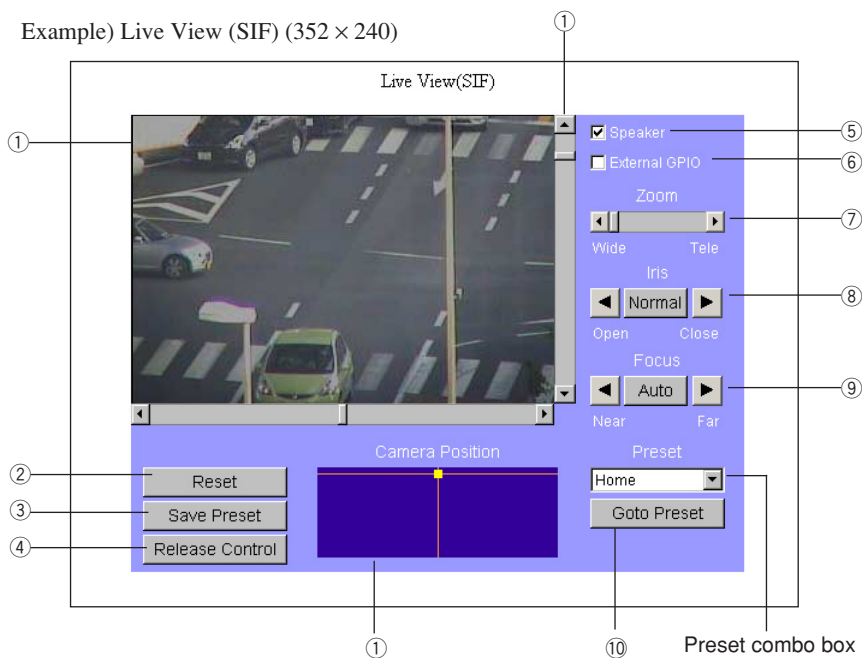

- ① PAN-TILT..... By sliding the scroll bar or clicking on Camera Position, the image moves to the designated coordinates. Clicking on the image moves it so that the clicked position will be the center of the image.
- ② Reset..... Matches the PAN-TILT position saved by the Camera with the actual position.

- ③ Save Preset Registers the current direction of the Camera head, the zoom position, the state of the focus, brightness level, and the preset number designated in the Preset combo box .
- ④ Release Control Registers the state of the focus and brightness at the preset number designated in the Preset combo box when the control policy is released on the Camera Control Setup screen (page 57).
- ⑤ Speaker..... Set whether to output sound from the client when sound is input through a microphone or another device connected.
- ⑥ External GPIO..... Turns ON or OFF a external GPIO terminal.
- ⑦ Zoom Zooms in or out the object.
Wide: The Wide side. The object is displayed small.
Tele: The Tele side. The object is displayed large.
- ⑧ Iris Adjusts the iris. The auto iris (the automatic adjustment function to keep brightness at the same level even if the state of the object changes) is valid at all times. Use the “Open” and “Close” buttons to “increase” or “decrease” brightness. By clicking on the “Normal” button, brightness will be adjusted to the normal level.
- ⑨ Focus For manual focal adjustment, use the “Near” and “Far” buttons. For automatic focal adjustment, click on the “Auto” button.
- ⑩ Preset..... Select in the preset combo box a preset you want to display the image to (setting range: Home, Preset 1-16.).
By clicking on the “Goto Preset” button, the registered preset appears.
By clicking on the “Save Preset” button, the current state will be registered at the preset number selected above.

(4) Capture display

Snapshots can be obtained in the JPEG format.

On the main page, select the image size you want to obtain from [Capture View (Half-D1)], [Capture View (SIF)], and [Capture View (QQVGA)].

The sizes of capture images are shown below.

- Half-D1 (704 × 240)
- SIF (352 × 240)
- QQVGA (160 × 120)

Note: Half-D1 displays 704 x 240 images in the size of 704 x 480.

Example) Capture View (SIF) (352 × 240)



• How to save snapshots

1. Click the right mouse button on the image.
2. Select “Save Image As” from the menu.
3. The image to be saved appears. Set a location for saving and a file name, and click on the [Save] button.

Note: Half-D1 size images are saved in 704 x 240, meaning that they are landscape. They can be viewed in the size of 704 x 480 on “Image Viewer” that is installed together with “ELMO 1Channel Viewer.”

Note: The procedure described above may depend on the browser.

(5) Settings

You can make all settings relating to the Camera.

You can jump to pages on which settings for the Camera can be made. To go to each setup page, click on the corresponding link on the screen shown below.

Note: You must log in with the authority of administrator to change settings.

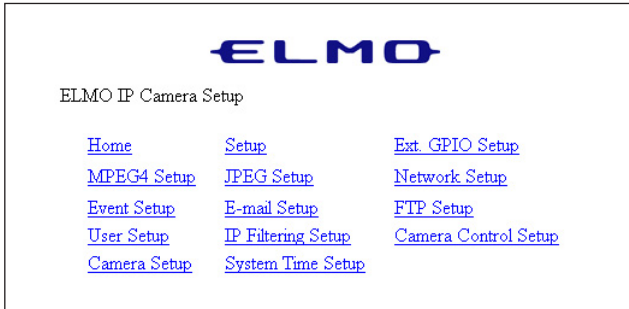

(6) External GPIO Setup

You can set the activation mode of the external GPIO.

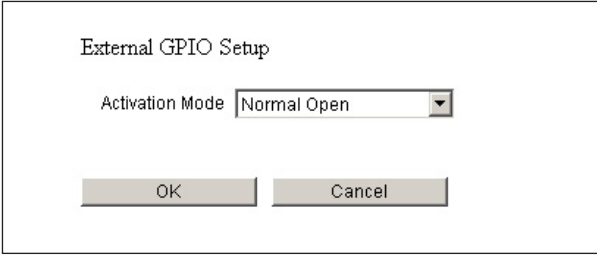

The image shows a dialog box titled "External GPIO Setup". Inside the dialog, there is a label "Activation Mode" followed by a dropdown menu. The dropdown menu is currently set to "Normal Open". Below the dropdown menu, there are two buttons: "OK" and "Cancel".

- Activation Mode Used to set the output mode of the external GPIO output terminal.
 - Normal Open..... Close the contact during output to keep continuity.
 - Normal Close Open the contact during output.

(7) MPEG4 Setup

Make settings for obtaining MPEG4 images.

Note: By changing this setting, the Camera itself may be reset and become incapable of distributing images for a while.

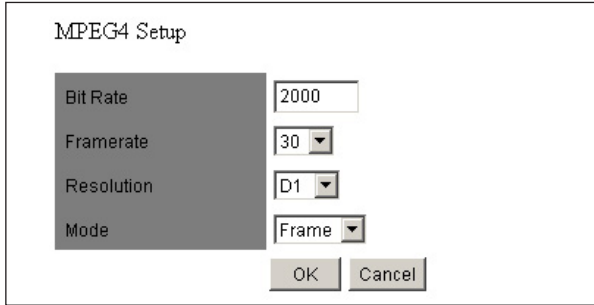

MPEG4 Setup

Bit Rate: 2000

Framerate: 30

Resolution: D1

Mode: Frame

OK Cancel

- Bit Rate Designate the upper limit to the data amount to limit the data amount generated during communication or image distribution (setting range: 64 to 2000 kbps).
- Framerate Designate the number of frames to be displayed per second (setting range: 30, 15, 10, 5, and 1 frames/second).

Note: Sound will not be received or transmitted when “1” is set at Framerate.

- Resolution Designate the size of images to be displayed.
D1: 704 × 480
SIF: 352 × 240
- Mode Set a delay for images according to the network environment.
Frame Reduces the delay for images.
GOP Enables the Camera to deal with a poor-performance network environment to some extent although the delay for image is long.

(8) JPEG Setup

Set image quality for JPEG images.

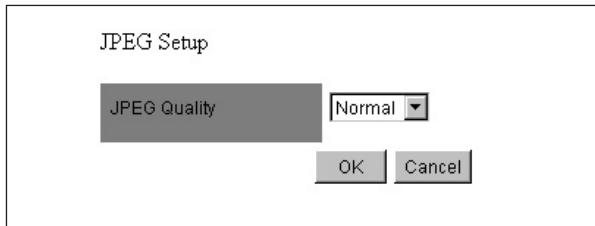

- JPEG Quality Designate image quality.
 - High..... High image quality. Although high-quality images can be obtained, the load on the transmission line increases.
 - Normal Medium image quality with a compression rate between High and Low.
 - Low Low image quality. The load on the transmission line decreases.

(9) Network Setup

Make settings relating to the network.

Note: Before making network settings, consult the administrator of the network you are going to use.

Note: If this item is changed, the connection setting for the Camera may need to be changed. In this case, make the proper connection setting, and reconnect the Camera.

Network Setup						
Send Type	UDP Unicast ▾					
IP	192	168	1	10		
Gateway	192	168	1	1		
DNS1	0	0	0	0		
DNS2	0	0	0	0		
Netmask	255	255	255	0		
Broadcast	192	168	1	255		
MAC Address	00	0c	2f	00	00	9a
Ports						
Start Port Range	3000					
End Port Range	4000					
HTTP Port	80					
Option Port	3491					
Multicast Port	3490					
RS-485						
RS-485 ID	1					
			OK	Cancel		

- Send Type Select a mode of distributing MPEG4 images.
 - UDP Unicast UDP image data is distributed at the request of the host for connection. Up to 3 addresses can be connected from Viewer to the Camera.
 - Multicast UDP image data is distributed, irrespective of whether the Camera is connected or is not connected from the host, resulting in a decrease in the load on the Camera and the transmission line. Although any number of addresses can be set, image data may not be distributed properly depending on the network environment.
 - TCP Unicast TCP image data is distributed at the request of the host for connection. Up to 3 addresses can be connected from Viewer to the Camera.
- IP Set the IP address of the Camera.
- Gateway Designate the IP address of a router when it is used to connect the Camera to an external network.
- DNS1/DNS2 Set the address of a DNS server to which the Camera is to be connected. At DNS2, set the address of the DNS server to which the Camera will be connected if it cannot connect to DNS1.
- Net mask Set the subnet mask address of the Camera.
- Broadcast Set the broadcast address of the Camera.
- MAC Address Displays the MAC address of the Camera.
- Start Port Range Designate the first of the ports the Camera opens to the network.
- End Port Range Designate the last of the ports the Camera opens to the network.
- HTTP Port Designate the port to be used for the Web server for the Camera (80, 1024 to 65535).
- Option Port Designate the port to be used for distributing images from the Camera (1024 to 65535).
- Multicast Port Designate the port to be used when the Camera is in multicast mode (1024 to 65535).
- Audio Port Designate the port to be used for transmitting and receiving sound to/from the Camera (1024 to 65535).
- RS-485 ID Set the ID address of the RS-485 of the Camera (1 to 223).

(10) Alarm Setup

Make settings relating to alarms.

Event1 Title	Event1
Event1 Action	None
Event1 Matched Resolution	SIF
Event2 Title	Event2
Event2 Action	None
Event2 Matched Resolution	SIF
Motion Detection Title	Motion
Motion Detection Action	None
Motion Detection Matched Resolution	SIF
Alarm1 Out	<input type="checkbox"/> Enable
Alarm2 Out	<input type="checkbox"/> Enable
Motion Detection Alarm Out	<input type="checkbox"/> Enable

OK Cancel

- Alarm 1 / 2 / Motion Detection Title

.....Set any desired title of alarm 1/ 2 or motion detection.

Note: Two-byte characters, including Japanese characters, are not available for a title. Use one-byte alphanumerical characters.

- Alarm 1 / 2 / Motion Detection Action

.....Select the action of the alarm when an alarm signal is input to the alarm input terminal.

None No action will take place.

Send FTP The JPEG file of the obtained snapshot will be transferred by FTP.

Send E-Mail E-mail will be transmitted.

Both The JPEG file of the obtained snapshot will be transferred by FTP and e-mail will be transmitted at the same time.

- Alarm 1 / 2 / Motion Detection Matched ResolutionDesignate the size of JPEG images to be attached when transferring the FTP or transmitting e-mail as set at Alarm 1/2 Action.
Half-D1: 704 × 240 SIF: 352 × 240 QQVGA: 160 × 120
- Alarm 1/2 Out Set whether to output an alarm when an alarm signal is input to alarm input 1 or 2.
- Motion Detection Alarm OutSet whether to give alarm output when a motion is detected.

(11) E-mail Setup

Make settings relating to e-mail.

The screenshot shows the 'E-mail Setup' dialog box with the following fields and options:

- To: [Text Input]
- From: [Text Input]
- CC1: [Text Input]
- CC2: [Text Input]
- CC3: [Text Input]
- SMTP: [Text Input]
- Use Authentication: Enable
- Use POP Before SMTP: Enable
- User ID: [Text Input]
- User PW: [Text Input]
- Message: [Text Input]
- Action: [Both] (Dropdown)

Buttons: OK, Cancel

- To..... Designate the address to which e-mail will be transmitted.
- From..... Designate the e-mail address of the Camera.
- CC1 to CC3 Designate an address to which e-mail will be transmitted at the same time when it is sent to the e-mail address set at To.
- SMTP..... Designate the SMTP server to be used.
- Use Authentication Designate whether to use user authentication on the SMTP server to be used.

- Use POP Before SMTP Designate whether to use POP before SMTP on the SMTP server to be used.
 - User ID Set a login ID for logging in to the SMTP server.
 - User PW Set a password for logging in to the SMTP server.
 - Message Set a character string to be sent as a message when transmitting e-mail.
- Note:** Two-byte characters, including Japanese characters, are not available for a message. Use one-byte alphanumeric characters.
- Action Select what to be sent when transmitting e-mail.
 - Text Only Only a character string will be sent when e-mail is transmitted.
 - Picture Only Only an image will be sent when e-mail is transmitted.
 - Both Both a character string and an image will be sent when e-mail is transmitted.

(12) FTP Setup

Make settings relating to FTP connection.

FTP Setup

IP		0	0	0	0
Port		21			
User ID					
User PW					
Directory					
Passive Mode		<input type="checkbox"/> Passive			
Time Store		<input type="checkbox"/> Enable			
Time Store login each send		<input type="checkbox"/> Login each send			
Time Store dwell time		30			
Time Store resolution		SIF			
Time Store filename		ptc401cip			

- IP Designate the IP address of the server to which the FTP will be transmitted.
- Port..... Designate the port number of the FTP server to which the FTP will be transmitted. It is not generally necessary to change the setting.
- User ID Designate an account name for connection to the server to which the FTP will be transmitted.
- User PW..... Designate a password for the account name shown above.
- Directory Designate a directory for saving an image file, or a directory with a write authority for the designated account name.
- Passive Mode..... Designate whether to use passive mode or active mode for transmitted the FTP. Use passive mode when there are restrictions on the ports because of a firewall, etc.
- Time Store Set whether to regularly transmit and save images in the FTP server.
- Time Store login each send .. Set whether to connect to the FTP server each time images are transmitted or not (always connected).
- Time Store dwell time Set the interval at which images will be saved when Time Store is valid (30 to 180 seconds).
- Time Store resolution Designate the size of images to be saved.
Half-D1: 704 × 240
SIF: 352 × 240
QQVGA: 160 × 120
- Time Store filename Designate a file name for the file to be saved. A file name consists of the “entered file name” and “time.” The extension “.jpg” will be added automatically to each file name. If a file with the same name already exists in the directory for saving, the data of the older file will be overwritten. Designate a different file name.

Note: Two-byte characters, including Japanese characters, are not available for a file name to be saved. Use one-byte alphanumerical characters.

(13) User Setup

Make settings relating to user administration.

The screenshot shows a 'User Setup' dialog box. At the top, the title is 'User Setup'. Below the title is a list box containing the text 'root,Admin'. Underneath the list box are three input fields: 'ID', 'Password', and 'Authority'. The 'Authority' field is a dropdown menu with 'Operator' selected. At the bottom of the dialog, there are three buttons: 'Add', 'Modify', and 'Remove', and two larger buttons: 'OK' and 'Cancel'.

- Adding a new user

You can register a login ID, a password, and authority for connection to the Camera. Designate an authority, enter a login ID and a password, and then click on the [Add] button. The entered data will be displayed in the list.

The following three items can be registered.

- Administrator..... The login ID for the administrator. The login ID is fixed to “root”. With this ID, you can view images, operate the Camera, and make settings.
- Operator..... You can view images and operate the Camera.
- User..... You can only view images.

* Only “root” can be registered for Administrator, and up to 99 names can be registered for Operator and User combined. You can use up to 16 one-byte characters for a name, including alphanumerical characters and upper-case and lower-case alphabetic characters.

Note: Two-byte characters, including Japanese characters, are not available for a login ID and pass word. Use one-byte alphanumerical characters.

- **Modifying a user**

You can modify the registered login ID, password, and authority of any user for connection to the Camera.

Select the user you want to modify from the list.

The currently registered data is displayed in the input area. Change the item(s) you desire, and click on the [Modify] button.

Note: With regard to “root,” only the password can be changed.

- **Deleting a user**

You can delete the registered login ID, password, and authority of any user for connection to the Camera.

Select the user you want to delete from the list, and click on the [Remove] button.

Note: You can not delete “root.”

(14) IP filtering Setup

Make settings relating to the IP filter.

Note: Making the settings described here may prevent connection to the Camera. Perform the setting operation with extreme care.

IP Filtering Setup

Enable IP Filter

Accept all

Reject all

Exception List

Start IP

End IP

- IP Filter Select whether to use the IP filter function.
- Accept all Accepts any client connected to the Camera, except connections from the IP addresses shown in Exception List. (Only connections from the IP addresses contained in the client list will be rejected.)
- Reject allRejects all clients attempting to connect to the Camera. It can be connected from the IP addresses shown in Exception List. (Only connections from the IP addresses in Exception List will be permitted.)

• Adding an address

You can add addresses between the start and end addresses to the list.

Enter an address at each of “Start IP” and “End IP,” and click on the [Add] button.

Note: Up to 100 addresses can be registered.

- **Modifying an address**

Select the address you want to modify from the list.

Change the “start address” and the “end address,” and click on the [Modify] button. The data will be corrected.

- **Deleting an address**

Select the address you want to delete from the list, and click on the [Remove] button.

(15) Camera Control Setup

Make settings relating to the Camera.

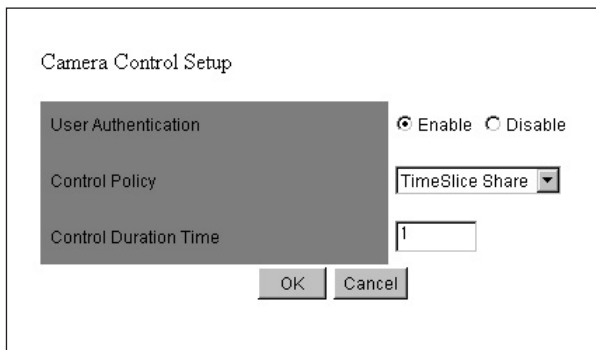

- **User Authentication**..... Select whether to output the Authentication screen to each client connected to the Camera. If authentication is not made, the authority of the client becomes operator. In this case, the Setting screen displays the Authentication window. Enter the ID and password of the administrator.
- **Control Policy**..... Designate the mode of controlling the Camera.
 - All-Time Share..... Constantly accepts operations from all clients.
 - Time Slice Share..... The operation authority will be released as soon as the time set at “Control Duration Time” passes away, and will be assigned to another connecting client. It will remain when there is no other connecting client.
- **Control Duration Time** Designate the period during which a client maintains control when “Time Slice Share” is selected at “Control Policy” (setting range: 1 to 60 minutes).

• Motion Detection Ignore Time After PTZ

..... Set a period for which motion detection is prevented after the Camera performs PAN/TILT/ZOOM when the motion detection function is enabled and a detection area is set.
(setting range : 1 to 10 seconds)

(16) Camera Settings

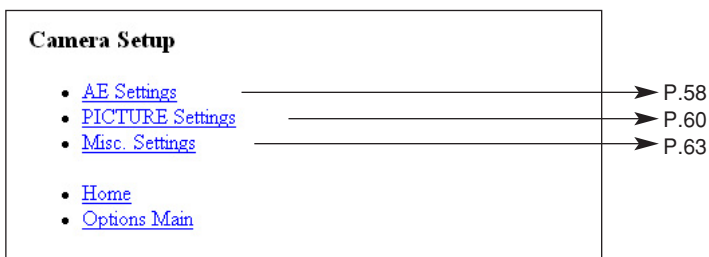

(17) Camera Settings (AE Settings)

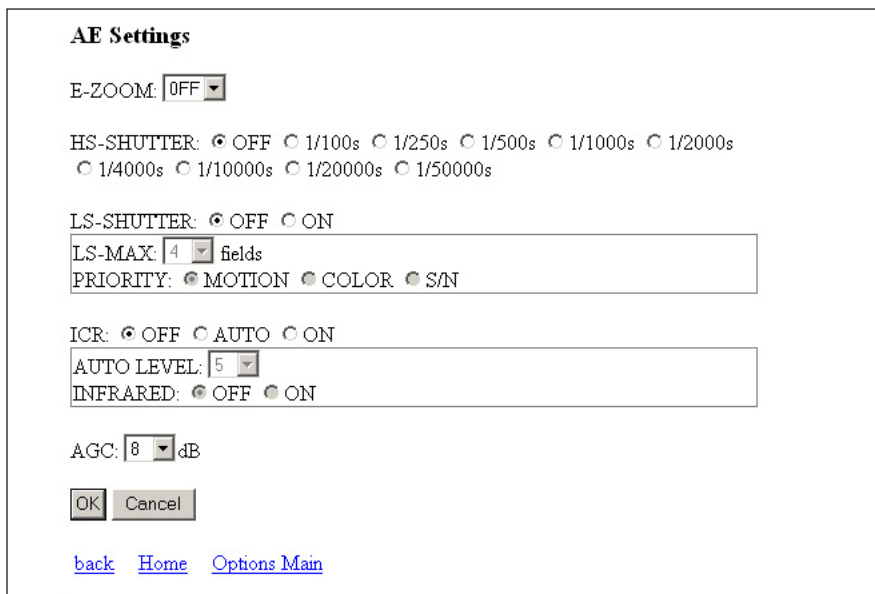

Name	Function	Factory Settings
E-ZOOM MAX	To set the maximum magnification [OFF, 1.5×, 2×, 2.5×, 3×, 4×, 6×, 8×, 16×]	OFF
HS-SHUTTER	To select the high-speed shutter speed [OFF (1/60s), 1/100s, 1/250s, 1/500s, 1/1000s, 1/2000s, 1/4000s, 1/10000s, 1/20000s, 1/50000s]. When [LS-SHUTTER] is [ON], the shutter speed can be selected from [1/60s 1/100s]. If the shimmer of fluorescent lamp is annoying when the shutter speed is set to [OFF (1/60s)], set the shutter speed to [1/100s], and the shimmer will be eased.	OFF
LS-SHUTTER	To set the low-speed shutter (electronic sensitivity up) to [ON/OFF]. When the object becomes dark, this function automatically varies the CCD accumulated time across several fields up to the set maximum level to optimize the brightness of the object.	OFF
LS-MAX	To set the maximum number of fields of the low-speed shutter [2fields, 3fields, 4fields, 5fields, 6fields, 8fields, 12fields, 20fields, 40fields, 80fields]. If the CCD accumulated time is set longer, the image frame rate will decrease, and moving object could not be seen well.	4fields
PRIORITY	To select the image attributes [MOTION, COLOR, S/N (fineness)] to be prioritized when [LS-SHUTTER] is selected and the object becomes dark.	MOTION
ICR	To set the DAY/NIGHT function (IR cut filter removable function). When this function is set to [AUTO], the filter is attached/removed automatically according to the brightness. When the IR cut filter is removed, the color image is switched to B&W image.	OFF
AUTO LEVEL	To select the timing of switching from B&W to color [1 – 15]. Particularly when the infrared illumination is intensive, select larger numeric value to prevent hunting.	5
INFRARED	To set the infrared illumination using mode to [ON/OFF] To use the infrared illumination, set this function to [ON]. If the infrared illumination is used with this function in the [OFF] status, the image could be out of focus.	OFF
AGC GAIN	To set the maximum gain of the AGC [0dB, 4dB, 8dB, 16dB, 20dB, 24dB]. The AGC is a function of amplifying the signal from the CCD to make the object visible when the object becomes dark.	8dB

(18) Camera Settings (Picture Settings)

PICTURE Settings

- [ALL POSITION](#)
- [HOME POSITION](#)
- [PRESET1](#)
- [PRESET2](#)
- [PRESET3](#)
- [PRESET4](#)
- [PRESET5](#)
- [PRESET6](#)
- [PRESET7](#)
- [PRESET8](#)
- [PRESET9](#)
- [PRESET10](#)
- [PRESET11](#)
- [PRESET12](#)
- [PRESET13](#)
- [PRESET14](#)
- [PRESET15](#)
- [PRESET16](#)

[back](#) [Home](#) [Options Main](#)

By clicking on an item, the corresponding setting screen appears.

PICTURE Settings - All Position

The selected item is displayed here.

BLC: OFF ON

BLC MODE: AREA HIST

AREA: 0 1 2 3 4

AP GAIN: ▾

WB: ATW AWC INDOOR OUTDOOR FL-LIGHT MWB

TRIGGER: OFF ON

MWB-R: ▾ MWB-B: ▾

[back](#) [Home](#) [Options Main](#)

Name	Function	Factory Settings									
BLC	To set the backlight compensation function to [ON/OFF]. When there is an intensive light in the background, this function prevents the object from becoming dark.	OFF									
BLC MODE	To select the Backlight Compensation Setting mode [AREA/HIST].	AREA									
About the Backlight Compensation Setting mode											
AREA	To select the image area of the object that needs an appropriate brightness and weighing according to the selected area.										
HIST	To make the dark (blackened) part of the image visible regardless of the area.										
AREA	To select the area [0 – 4] on the image where the backlight compensation function works when [AREA] is selected. <div style="text-align: center; border: 1px solid black; padding: 5px; width: fit-content; margin: 0 auto;"> <table border="1" style="border-collapse: collapse;"> <tr> <td colspan="3" style="text-align: center;">AREA0</td> </tr> <tr> <td style="text-align: center;">AREA3</td> <td style="text-align: center;">AREA4</td> <td style="text-align: center;">AREA2</td> </tr> <tr> <td colspan="3" style="text-align: center;">AREA1</td> </tr> </table> </div>	AREA0			AREA3	AREA4	AREA2	AREA1			4
AREA0											
AREA3	AREA4	AREA2									
AREA1											
AP GAIN	To select the detail compensation level [-5 ~10]	±0									
WB	To select the White Balance Setting mode [ATW, AWC, INDOOR, OUTDOOR, FL-LIGHT, MWB].	ATW									
About the White Balance Setting mode											
ATW	To adjust the white balance by way of continuous, automatic following. (When the image is in a single color all over, the white balance may not be adjusted correctly.)										
AWC	To adjust the white balance by one-push of button. When [AWC] is selected and TRIGGER is ON, the white balance is adjusted automatically in the then screen status. (This adjustment ends in seconds, and the adjusted value is fixed.)										

Name		Function	Factory Settings
	INDOOR	This function is selected when the Camera is used indoors. The color temperature is assumed to be 3200K.	
	OUTDOOR	This function is selected when the Camera is used outdoors. The color temperature is assumed to be 6300K.	
	FL-LIGHT	This function is selected when the Camera is used under the fluorescent illumination. The color temperature is assumed to be 4200K.	
	MWB	To change the color tendency as desired.	
	MWB-R	To set the red color tendency [-30~+30] when [MWB] is selected.	±0
	MWB-B	To set the blue color tendency [-30~+30] when [MWB] is selected.	±0

(19) Camera Settings (Misc. Settings)

Misc. Settings

AUTO RETURN: OFF 30s 1m 2m 5m 10m 20m 30m

PRESET STILL: OFF ON

FLIP ANGLE: OFF 100 110 120 130 140

ALARM IN1:

ALARM LOCK: OFF ON

ALARM IN2:

[back](#) [Home](#) [Options Main](#)

Name	Function	Factory Settings
AUTO RETURN	To set the time of automatic return to the home position [OFF, 30s, 1min, 2min, 5min, 10min, 20min, 30min] If it has passed over this set time with no operation after the PAN-TILT-ZOOM operation, the Camera will return automatically to the home position.	OFF
PRESET STILL	When this function is set to [ON], the image during the movement between the preset positions becomes static (the image before the movement). In this mode, movement is enabled between the preset positions (including the home position), but the PAN-TILT-ZOOM operation is disabled. This function is useful to mask the images other than the home position image and the preset position images. (However, only when the PRESET button is pressed, the image cannot be static.)	OFF
FLIP ANGLE	To select the image reverse angle [OFF, 100°, 110°, 120°, 130°, 140°] (When the image should not be reserved, set this function to [OFF].)	120
ALARM IN1	To set the preset position [PRESET1 – 16] for movement in case of input in the ALARM IN terminal <1>	PRESET1
ALRAM LOCK	When this function is set to [ON], as long as the input is in the ALARM IN terminal <1>, other operations are disabled. (Set this function to [ON/OFF].)	OFF
ALARM IN2	To set the preset position [PRESET1 – 16] for movement in case of input in the ALARM IN terminal <2>.	PRESET2

(20) System Time Setup

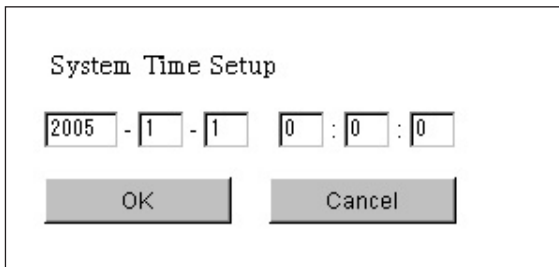

A dialog box titled "System Time Setup" with a white background and a black border. It contains a date and time input field. The date is set to 2005-1-1 and the time is set to 0:0:0. Below the input field are two buttons: "OK" and "Cancel".

System Time Setup

2005 - 1 - 1 0 : 0 : 0

OK Cancel

Set the internal clock of the Camera. The time of this clock will be added to the file name when sending an E-mail or FTP.

[4] MPEG4 Viewer software [ELMO 1Channel Viewer]

(1) Restrictions

Access to the Camera through “ELMO 1Channel Viewer” (hereinafter referred to as “Viewer”) needs your computer to meet the following operating requirements:

- Microsoft Windows 2000 or XP.
- DirectX 9.0C or a later version is installed.

Note: The camera does not always ensure the proper operation of Viewer in all environments.

(2) Connection

• At the time of the initial startup

1. Run the Viewer program, and a window for registering a Viewer ID and a password appears.

Register your ID and password.



Note: Do not forget your Viewer ID and password because they are required whenever you use the Viewer software. If you forget them, the software must be reinstalled.

2. After the registration of your Viewer ID and password, the languages you can select, “Japanese” and “English” are displayed. Select either language in which you will use the software.

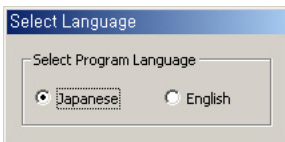

- At the second and subsequent startups

1. Once you run the Viewer program, the window for entering a login ID and a password appears. Enter your registered login ID and password.

Note: If you enter a wrong login ID or password three times, the program will be exited.

2. Viewer's main screen is displayed.

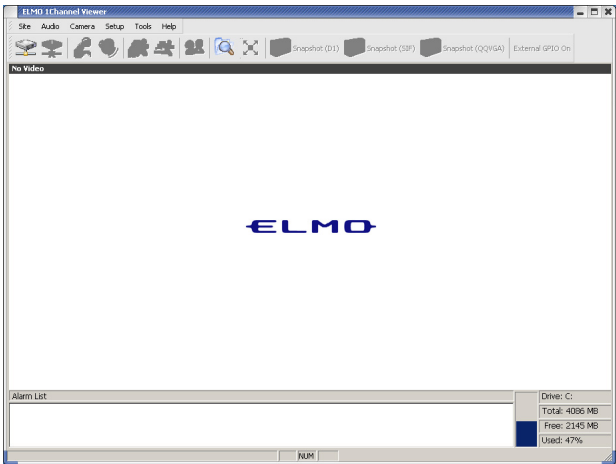

3. Select [Camera] – [Connect], and the Connect Dialog screen appears.

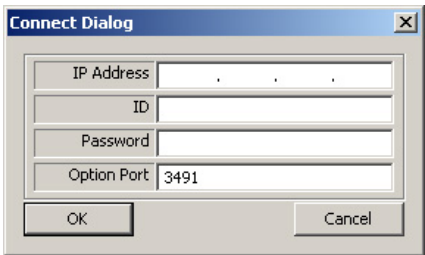

4. Enter the IP address, login name (ID), password, and connection port of the Camera you want to connect, and click on the [OK] button. Viewer will be connected to the Camera, and the screen will display an MPEG4 image and the PTZ Control Panel.

(3) Live display

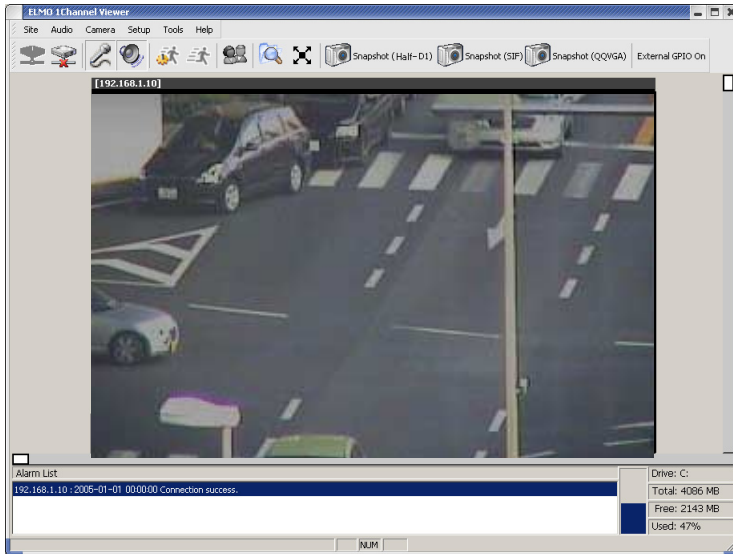

On the image, it displays in a full monitor of the window when double-clicking, and the image is displayed in a full window. It returns to former display when double-clicking it again.

• Obtaining snapshots

You can save snapshots, which are in sizes of Half-D1, SIF, and QQVGA, on the Camera in a specific folder.

Select [Still] from the menu bar, or click on one of the [Half-D1], [SIF], and [QQVGA] buttons on the tool bar.



The specific sizes of snapshots are shown below.

- Half-D1 (704 × 240)
- SIF (352 × 240)
- QQVGA (160 × 120)

- PTZ Control

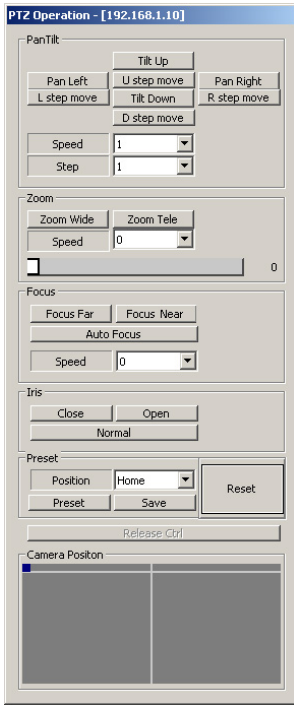

- Camera Position..... By sliding the scroll bar or clicking on Camera Position, the image moves to the designated coordinates. Clicking on the image moves it so that the clicked position will be the center of the image.
- Pan Tilt
 - Pan & Tilt buttons Used to operate PAN-TILT.
 - Step move..... PAN-TILT takes place at designated intervals of move according to the setting of “Step” each time the button is pressed.
 - Speed..... The operating speed of PAN-TILT can be set (setting range: 1 to 15).
 - Step The number of steps can be set (setting range: 1 to 7).
- Zoom
 - Zoom Wide The WIDE side. The object is displayed small.
 - Zoom Tele..... The TELE side. The object is displayed large.
 - Zoom Speed Used to set the zoom speed (setting range: 0 to 2).
 - Zoom Scroll The zoom position can be set using the scroll bar.

- Focus
 - Focus Near/Focus Far Used to adjust the focus manually.
 - Auto Focus Used to adjust the focus automatically.
- Iris
 - Open / Close.....Adjusts the iris.
 - NormalAdjusts the brightness to the normal level.



*The auto iris (the automatic adjustment function to keep brightness at the same level even if the state of the object changes) is valid at all times.
- Preset
 - Select a preset you want to display in Camera Position
(setting range: Home, Preset: 1 to 16).
 - Preset..... The registered preset is displayed.
 - Save..... Registers the current coordinates in the preset selected above.
 - Reset..... The PAN-TILT position saved by the Camera and the actual position match each other.
- Preset Control This function is available when Time Slice Share is set for Control Policy in camera control setup (page 87) and opens the control of the Camera. It does not open control when there is no client requesting it.

(4) Sound



You can set the receipt and transmission of Camera sound.

Note: This function does not operate when 1 is set at Frame Rate on the MPEG4 Setup screen.

- Receiving sound

Confirm that the speaker is connected properly to the host. When sound is input into the Camera with the [Audio] – [Speaker] button in the Viewer menu or the  icon on the icon bar clicked on, the speaker connected to the host outputs it. No sound will be output from the speaker connected to the host if the  icon is not clicked on.

- **Outputting sound**

Confirm that the connection between the Camera and the loudspeaker with an amplifier and the connection between the client and the microphone are proper. When sound is input into the microphone connected to the client with [Audio] – [Microphone] button in the Viewer menu or the  icon on the icon bar clicked on, the loudspeaker with an amplifier connected to the Camera outputs it. No sound will be output from the loudspeaker with an amplifier connected to the Camera if the  icon is not clicked on.

(5) Settings

You can change the settings for the Camera.

Select [Setup] from the menu bar, and the setting menu shown below appears.

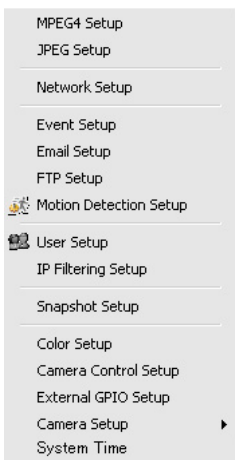

For further information about each setting, see (6) to (22) that follow.

(6) MPEG4 Setup

Make settings for obtaining MPEG4 images.

Note: By changing this setting, the Camera itself may be reset and become incapable of distributing images for a while.

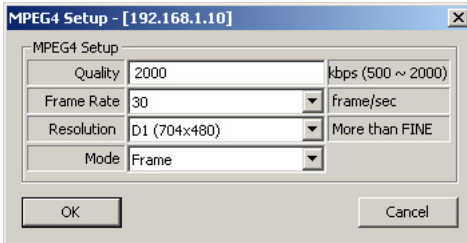

- Quality Designate the upper limit to the data amount to limit the data amount generated during communication or image distribution (setting range: 64 to 2000 kbps).
- Frame Rate..... Designate the number of frames to be displayed per second (setting range: 30, 15, 10, 5, and 1 frames/second).

Note: Sound will not be received or transmitted when “1” is set at Framerate.

- Resolution..... Designate the size of images to be displayed.
D1: 704 × 480
SIF: 352 × 240
- Mode..... Set a delay for images according to the network environment.
Frame Reduces the delay for images.
GOP..... Enables the Camera to deal with a poor-performance network environment to some extent although the delay for image is long.

(7) JPEG Setup

Set image quality for JPEG images.

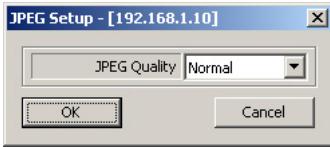

- JPEG Quality Designate image quality.
 - High..... High image quality. Although high-quality images can be obtained, the load on the transmission line increases.
 - Normal Medium image quality with a compression rate between High and Low.
 - Low Low image quality. The load on the transmission line decreases.

(8) Network Setup

Make settings relating to the network.

Note: Before making network settings, consult the administrator of the network you are going to use.

Note: If this item is changed, the connection setting for the Camera may need to be changed. In this case, make the proper connection setting, and reconnect the Camera.

Send Type	
Send Type	UDP Unicast

Network			
IP	192 . 168 . 1 . 10	Broadcast	192 . 168 . 1 . 255
Netmask	255 . 255 . 255 . 0	Gateway	192 . 168 . 1 . 1
DNS1	0 . 0 . 0 . 0	DNS2	0 . 0 . 0 . 0
MAC address	00:0c:2f:00:00:9a		

Port			
HTTP Port	80	Option Port	3491
Multicast Port	3490	Audio Port	3493

Unicast Mode Port Range			
Start Port	3000	End Port	4000

RS-485	
RS-485 ID (1~223)	1

OK Cancel

- Send Type Select a mode of distributing MPEG4 images.
 - UDP Unicast UDP Image data is distributed at the request of the host for connection. Up to 3 addresses can be connected from Viewer to the Camera.
 - Multicast UDP Image data is distributed, irrespective of whether the Camera is connected or is not connected from the host, resulting in a decrease in the load on the Camera and the transmission line. Although any number of addresses can be set, image data may not be distributed properly depending on the network environment.
 - TCP Unicast TCP image data is distributed at the request of the host for connection. Up to 3 addresses can be connected from Viewer to the Camera.
- IP Set the IP address of the Camera.
- Broadcast Set the broadcast address of the Camera.

- Net mask Set the subnet mask of the Camera.
- Gateway Designate the IP address of a router when it is used to connect the Camera to an external network.
- DNS1/DNS2 Set the address of a DNS server to which the Camera is to be connected. At DNS2, set the address of the DNS server to which the Camera will be connected if it cannot connect to DNS1.
- MAC Address Displays the MAC address of the Camera.

- HTTP Port..... Designate the port to be used for the Web server for the Camera (80, 1024 to 65535).
- Option Port Designate the port to be used for distributing images from the Camera (1024 to 65535).
- Multicast Port Designate the port to be used when the Camera is in multicast mode (1024 to 65535).
- Audio Port..... Designate the port to be used for transmitting and receiving sound to/from the Camera (1024 to 65535).

- Start Port Range Designate the first of the ports the Camera opens to the network.
- End Port Range Designate the last of the ports the Camera opens to the network.

- RS-485 ID Set the ID address of the RS-485 of the Camera (1 to 223).

(9) Alarm Setup

Make settings relating to alarms.

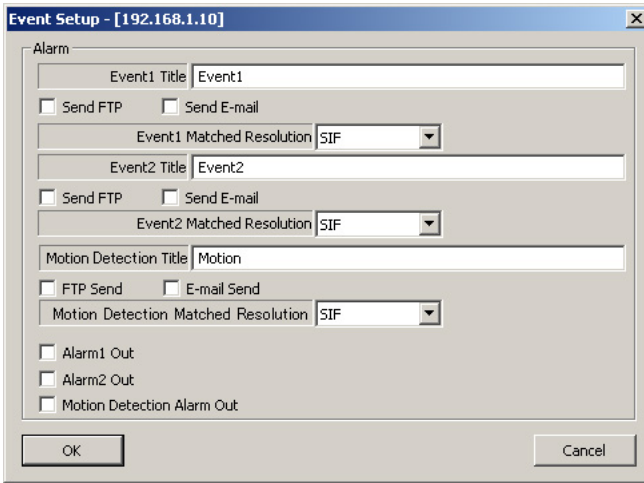

- Alarm 1 / 2 / Motion Detection Title

.....Set any desired title of alarm 1/ 2 or motion detection .

Note: Two-byte characters, including Japanese characters, are not available for a title. Use one-byte alphanumeric characters.

- Alarm 1 / 2 / Motion Detection Action

.....Select the action of the alarm when an alarm signal is input to the alarm input terminal.

None No action will take place.

Send FTP..... The JPEG file of the obtained snapshot will be transferred by FTP.

Send E-Mail E-mail will be transmitted.

Both..... The JPEG file of the obtained snapshot will be transferred by FTP and e-mail will be transmitted at the same time.

- Alarm 1 / 2 / Motion Detection Matched Resolution

.....Designate the size of JPEG images to be attached when transferring the FTP or transmitting e-mail as set at Alarm 1/2 Action or motion detection.

Half-D1: 704 × 240

SIF: 352 × 240

QQVGA: 160 × 120

- Alarm 1/2 Output..... Set whether to output an alarm when an alarm signal is input to alarm input 1 or 2.
- Motion Detection Alarm Out.....Set whether to give alarm output when a motion is detected.

(10) E-mail Setup

Make settings relating to e-mail.

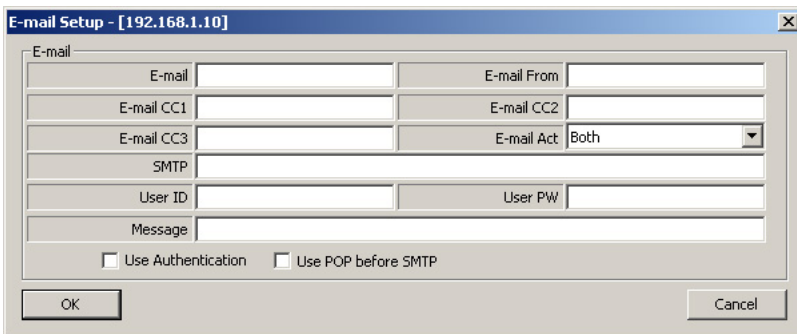

- E-mail Designate the address to which e-mail will be transmitted.
- E-mail From..... Designate the e-mail address of the Camera.
- E-mail CC1 to CC3..... Designate an address to which e-mail will be transmitted at the same time when it is sent to the e-mail address set at To.
- E-mail Act..... Select what to be sent when transmitting e-mail.
 - Text Only Only a text will be sent when e-mail is transmitted.
 - Picture Only Only an image will be sent when e-mail is transmitted.
 - Both..... Both a text and an image will be sent when e-mail is transmitted.
- SMTP..... Designate the SMTP server to be used.
- User ID Set a login ID for logging in to the SMTP server.
- User PW..... Set a password for logging in to the SMTP server.
- Message Set a text to be sent as a message when transmitting e-mail.

Note: Two-byte characters, including Japanese characters, are not available for a title. Use one-byte alphanumerical characters.

- Use Authentication Designate whether to use user authentication on the SMTP server to be used.
- Use POP before SMTP Designate whether to use POP before SMTP on the SMTP server to be used.

(11) FTP Setup

Make settings relating to connection.

The screenshot shows a dialog box titled "FTP Setup - [192.168.1.10]". It has two main sections: "FTP Server" and "Action".

FTP Server section:

- IP: 0 . 0 . 0 . 0
- Port: 21
- Directory: (empty)
- User ID: (empty)
- User PW: (empty)
- Passive Mode

Action section:

- Time Store Dwell Time: 30
- Time Store Resolution: SIF (dropdown menu)
- Time Store filename: ipcam
- Time Store Enable
- Login each send

Buttons: OK, Cancel

- IP..... Designate the IP address of the server to which the FTP will be transmitted.
- Port..... Designate the port number of the FTP server to which the FTP will be transmitted. It is not generally necessary to change the setting.
- Directory..... Designate a directory for saving an image file, or a directory with a write authority for the designated account name.
- User ID Designate an account name for connection to the FTP server to which the FTP will be transmitted.
- User PW..... Designate a password for the account name shown above.
- Passive Mode..... Designate whether to use passive mode or active mode for transferring the FTP. Use passive mode when there are restrictions on the ports because of a firewall, etc.
- Time Store Dwell Time Set the interval at which images will be saved when Time Store is valid (30 to 180 seconds).
- Time Store Resolution..... Designate the size of images to be saved.
Half-D1: 704 × 240
SIF: 352 × 240
QQVGA: 160 × 120

- Time Store filename Designate a file name for the file to be saved. A file name consists of the “entered file name” and “time.” The extension “.jpg” will be added automatically to each file name. If a file with the same name already exists in the directory for saving, the data of the older file will be overwritten. Designate a different file name.

Note: Two-byte characters, including Japanese characters, are not available for a file name to be saved. Use one-byte alphanumerical characters.

- Time Store Enable Set whether to regularly save images in the FTP server.
- Login each send Set whether to connect to the FTP server each time images are transmitted or not (always connected).

(12) Motion Detection Setup

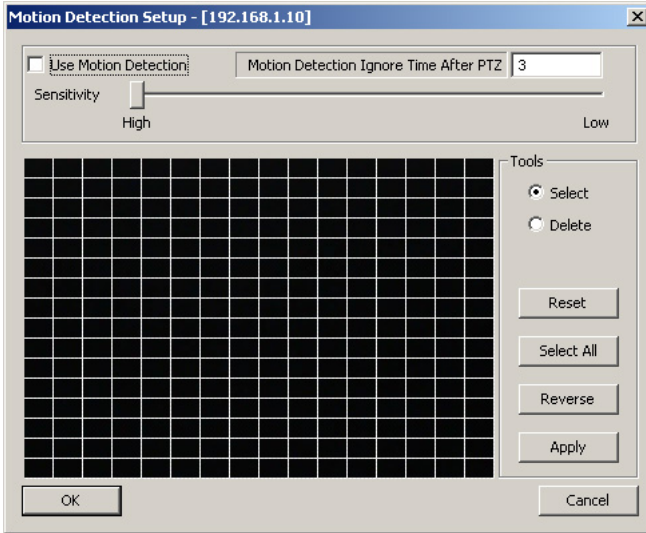

- Use Motion Detection..... Set whether to perform motion detection.
- Motion Detection Ignore Time After PTZ
..... Set a time for which motion detection is prevented after the Camera performs PAN/TILT/ZOOM (1 to 10 seconds).
- Sensitivity Set the sensitivity of motion detection.

• Area settings

When “Select” under “Tools” is checked, the area on the screen that is selected by drag & drop will be set for a motion detection area. When “Delete” is checked, the set motion detection area will be cancelled.

[Reset] button: Cancels all areas.

[Select All] button: Sets all areas.

[Reverse] button: Reverses a detection area to non-detection area and vice versa.

[Apply] button: Applies the settings made.

(13) User Setup

Make settings relating to user administration.

User ID	User Authority
root	Admin

Form fields and buttons:

- ID:
- Password:
- Authority: (dropdown menu)
- Confirm:
- Buttons: Add, Modify, Remove, OK, Cancel

• Adding a new user

You can register a login ID, a password, and authority for connection to the Camera. Designate an authority, enter a login ID and a password, and then click on the [Add] button. The entered data will be displayed in the list.

The following three items can be registered.

- Administrator..... The login ID for the administrator. The login ID is “root” that is unchangeable. With this ID, you can view images, operate the Camera, and make settings.
 - Operator You can view images and operate the Camera.
 - User..... You can only view images.
- * Only “root” can be registered for Administrator, and up to 99 names can be registered for Operator and User combined. You can use up to 16 one-byte characters for a login ID and password, including alphanumerical characters and upper-case and lower-case alphabetic characters.

Note: Two-byte characters, including Japanese characters, are not available for a login ID and password. Use one-byte alphanumerical characters.

- **Modifying a user**

You can modify the registered login ID, password, and authority of any user for connection to the Camera.

Select the user you want to modify from the list.

The currently registered data is displayed in the input area. Change the item(s) you desire, and click on the [Modify] button.

Note: With regard to “root,” only the password can be changed.

- **Deleting a user**

You can delete the registered login ID, password, and authority of any user for connection to the Camera.

Select the user you want to delete from the list, and click on the [Remove] button.

Note: You cannot delete “root.”

(14) IP filtering Setup

Make settings relating to the IP filter.

Note: Making the settings described here may prevent connection to the Camera. Perform the setting operation with extreme care.

No.	Start IP	End IP
1	0.0.0.0	0.0.0.0
2	0.0.0.0	0.0.0.0
3	0.0.0.0	0.0.0.0
4	0.0.0.0	0.0.0.0
5	0.0.0.0	0.0.0.0
6	0.0.0.0	0.0.0.0
7	0.0.0.0	0.0.0.0
8	0.0.0.0	0.0.0.0
9	0.0.0.0	0.0.0.0
10	0.0.0.0	0.0.0.0
11	0.0.0.0	0.0.0.0
12	0.0.0.0	0.0.0.0
13	0.0.0.0	0.0.0.0

- **Enable IP Filtering**..... Select whether to use the IP filter function.
- **Accept All**..... Accepts any client connected to the Camera, except connections from the IP addresses shown in Exception List. (Only connections from the IP addresses contained in the client list will be rejected.)
- **Reject All**.....Rejects all clients attempting to connect to the Camera. It can be connected from the IP addresses shown in Exception List. (Only connections from the IP addresses in Exception List will be permitted.)
- **Modifying an address**
Select the address you want to modify from the list.
Change the address set at each of “Start IP” and “End IP,” and click on the [Modify] button.
- **Deleting an address**
Select the address you want to delete from the list, and click on the [Remove] button.
- **Reset**
The button sets all addresses registered in the list at “0.0.0.0.”

(15) Snapshot Setup

Make settings relating to snapshots on this screen.

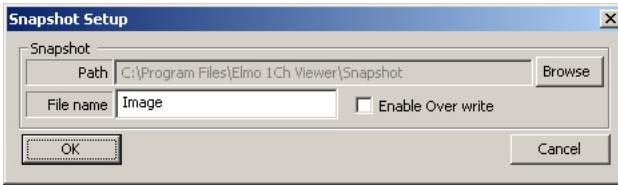

- Path Set a directory for saving snapshots. You can refer to folders with the [Browse] button.
- File name Designate a file name to be saved.
- Enable Overwrite Enables the overwrite of the last saved snapshot when saving a new snapshot with the same file name.

(16) Color Setup

Set the brightness, contrast, hue, and saturation of images on this screen.

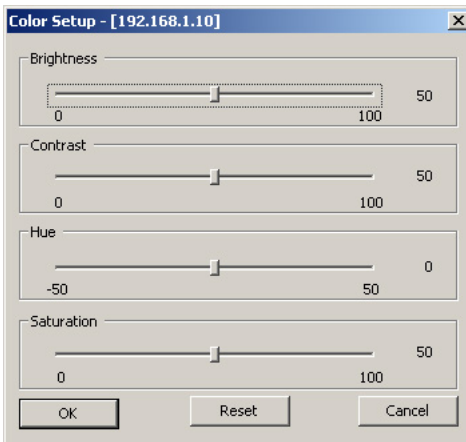

(17) Camera Control Setup

Make settings relating to the Camera.

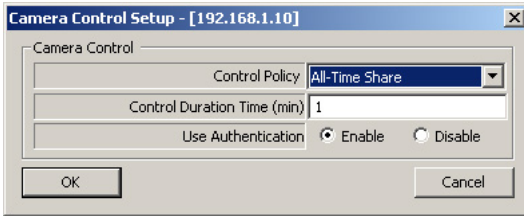

- Control Policy Designate the mode of controlling the Camera.
 - All-Time Share The control policy remains unless the client having an operation authority cuts off the connection.
 - Time Slice Share The operation authority will be released as soon as the time set at “Control Duration Time” passes away, and will be assigned to another connecting client. It will remain when there is no other connecting client.
- Control Duration Time Designate the period during which a client maintains control when “Time Slice Share” is selected at “Control Policy” (setting range: 1 to 60 minutes).
- User Authentication Select whether the login ID and the password must be input on the authentication screen for a client to be connected to the Camera. When “Disable” is selected, you do not need to input the login ID and the password on the Connection Setting screen, and “operator control” becomes valid once you log in. When you desire to log in as administrator, input the login ID and password for it.

(18) External GPIO Setup

You can set the activation mode of the external GPIO.

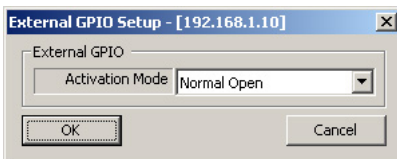

- Activation Mode Used to set the output mode of the external GP10 output terminal.
 Normal Open..... Closes the contact during output to keep continuity.
 Normal Close Opens the contact during output.

(19) Camera Settings (AE Settings)

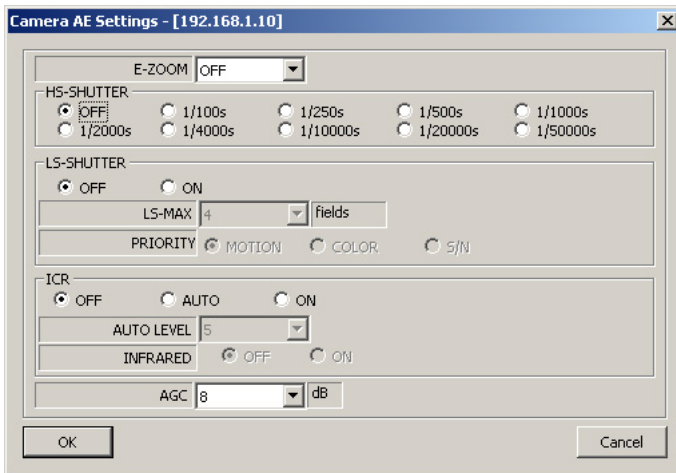

For each setting item, see the description of each function on page 59.

(20) Camera Settings (Picture Settings)

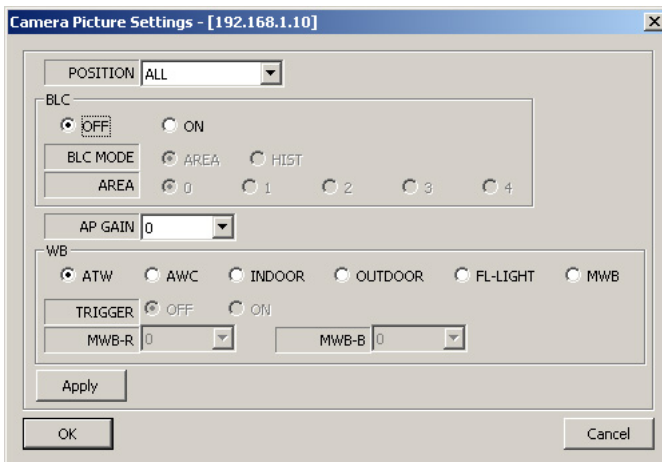

For each setting item, see the description of each function on page 61.

(21) Camera Settings (Misc. Settings)

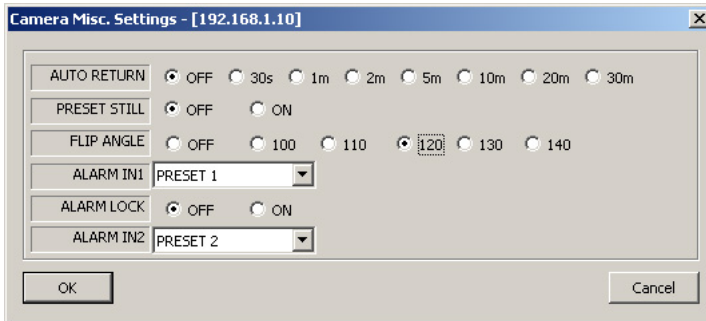

For each setting item, see the description of each function on page 63.

(22) System Time Setup

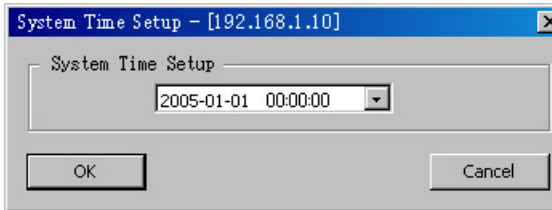

Set the internal clock of the Camera. The time of this clock will be added to the file name when sending an E-mail or FTP.

(23) Tools

Select [Tools] from the menu bar, and the Tool menu shown below appears.

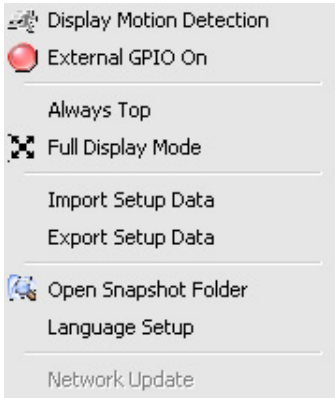

- Display Motion Detection Displays an area in which some motion is detected on the MPEG4 live image screen.
- External GPIO On Turns ON or OFF output from the general-purpose output terminal.
- Always Top..... Displays Viewer on top of the other screens displayed at all times even if it is not active.
- Full Display Mode Displays the image in the entire window, irrespective of the image's aspect ratio.
- Import Setup Data..... Enables you to set on the Camera set values saved in the PC (available only when the Camera is connected).
- Export Setup Data..... Enables you to save set values in the PC (available only when the Camera is connected).
- Open Snapshot Folder Opens the file designated at Path on the Snapshot Setup screen.
- Language Setup Set English or Japanese for Viewer (the selection becomes valid after Viewer is turned OFF and ON again).
- Network Update..... Rewrites the firmware for the Camera networked.

(24) Firmware update

You can update the firmware for the Camera (Camera operation programs) via a network for the purpose of improving its functions.

Since an update changes the key functions of the Camera, it may fail to get started or malfunction if the update is not carried out correctly.

Update the firmware according to the procedure described below with extreme care.

Note: Updating the firmware may clear some settings stored in the Camera. Export all of the settings for the Camera before updating the firmware, and import them back into it after the update is completed.

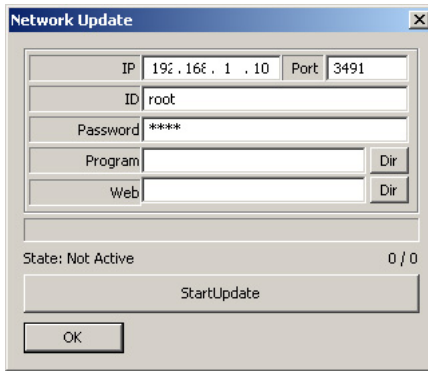

Do not attempt to modify the firmware for firmware updating that was distributed by the shop where you purchased the product or our branch or sales office nearby. Using another firmware or modified firmware may cause the Camera to malfunction.

1. To save the current set data on the Camera in the host, select [Tool] – [Export Setup Data] from the menu of Viewer.
2. Turn OFF the power to the Camera, and connect it and the host one-to-one with a cross cable.
3. Set the network for the host according to the network address of the Camera.
4. Turn ON the power to the Camera, and select [Tool] – [Network Update] from the menu of Viewer on the host.
5. The Net Update window opens. Set correct data at each of IP (the Camera's IP address), Port (the Camera's optional port number), ID (the Camera's root login name), and Password (the Camera's root login password).

6. Designate the program file for updating firmware distributed by the shop where you purchased the product or our branch or sales office nearby, and the program file for the Web.
7. Click on the [Start Update] button at the bottom of the screen.
8. The state shown on the line named [State] is updated, and “Complete” is displayed after the update is properly completed. If “Error Connect” is displayed, the connection or any of the network settings is incorrect. Reconfirm the connection between the Camera and the host and the network settings.
9. After the firmware is updated properly, the Camera completes getting restarted within several seconds and gets ready to be connected. Click on the [OK] button to close the Firmware Update window.
10. Confirm the network settings, and select [Tool] -> [Import Setup Data] from the menu of Viewer to import the setting before firmware updating into the Camera.
11. Connect the Camera to the network to which it was connected before updating to confirm that it properly works.

[5] Set items

● Camera ID, password

Name	Function	Factory settings
ID	<p>The following three items can be set according to the user settings:</p> <p>Administrator: The login ID for the administrator. The login ID is “root” that is unchangeable. With this login ID, you can view images, operate the Camera, and make settings.</p> <p>Operator: You can view images and operate the Camera.</p> <p>User: You can only view images.</p> <p>* Only “root” can be registered for Administrator, and up to 99 names can be registered for Operator and User combined.</p> <p>* You can use up to 16 one-byte characters for a name, including alphanumerical characters and upper-case and lower-case alphabetic characters.</p>	root (Administrator)
Password	<p>Set a password for the ID.</p> <p>* You can use up to 16 one-byte characters for a password, including alphanumerical characters and upper-case and lower-case alphabetic characters.</p>	root

● ELMO 1Channel Viewer ID, password

Name	Function	Factory settings
ID	<p>Set an ID.</p> <p>Set it at the initial use of ELMO 1Channel Viewer after it was installed. Once it is registered, you cannot change it.</p>	(none)
Password	<p>Set a password for the ID.</p> <p>Set it at the initial use of ELMO 1Channel Viewer after it was installed. Once it is registered, you cannot change it.</p>	(none)

● External GPIO

Name	Function	Factory settings
Activation Mode	<p>Set the output mode.</p> <p>Normal Open: High impedance is usually activated, and the GND level becomes valid during output.</p> <p>Normal Close: The GND level is usually activated, and high impedance becomes valid during output.</p>	Normal Open

● MPEG4

Make settings for MPEG4 display using “ELMO 1Channel Viewer.”

Name	Function	Factory settings
Quality	Designate the upper limit to the data amount to limit the data amount generated during communication or image distribution. Frame: 500 - 2000 (kbps) GOP: 64 - 2000 (kbps)	2000(kbps)
Framerate	Designate the number of frames to be displayed per second. (setting range: 30, 15, 10, 5, and 1 frames/second).	30(frames/second)
Resolution	Designate the size of images to be displayed. D1 (704 x 480) , SIF(352 x 240)	D1
Mode	Set a delay for images according to the network environment. Frame: Reduces the delay for images. GOP: Enables live images to be viewed even on a poor-performance network although the delay for images is long.	frame

● JPEG

Make settings for motion JPEG display and capture display using a browser and for snapshot acquisition using “ELMO 1Channel Viewer.”

Name	Function	Factory settings
JPEG Quality	Designate image quality. High: High image quality. Normal: Medium image quality with a compression rate between High and Low. Low: Low image quality.	Normal

● Network

Consult the administrator of the network you intend to use before making network settings.

Name	Function	Factory settings
MPEG4 Send Type	Select a MPEG4 distribution method. Unicast: The mode of transmitting data to each address designated. Multicast: The mode of transmitting the same data to plural addresses on the same network.	UDP Unicast
IP address	Set the IP address of the Camera.	192.168.1.10
Gateway	Designate the IP address of a router when it is used to connect the Camera to an external network.	0.0.0.0
DNS1	Set the address of a DNS server to which the Camera is to be connected.	0.0.0.0
DNS2	Set the address of the DNS server to which the Camera will be connected if it cannot connect to DNS1.	0.0.0.0
Subnet mask	Set the subnet mask address of the Camera.	255.255.255.0
Broadcast	Set the broadcast address of the Camera.	192.168.1.255
Start Port Range	Designate the first of the ports the Camera opens to the network.	3000
End Port Range	Designate the last of the ports the Camera opens to the network.	4000
HTTP Port	Designate the port to be used for the Web server for the Camera.	80
Option Port	Designate the port to be used for distributing images from the Camera	3491
Multicast Port	Designate the port to be used when the Camera is in multicast mode.	3490
Audio Port	Designate the port to be used for transmitting and receiving sound to/from the Camera.	3493
RS-485 ID	Set the ID address of the RS-485 of the Camera. 1~223	1

● Alarm

Name	Function	Factory settings
Alarm 1 Title	Set any desired title of alarm 1. *Two-byte characters, including Japanese characters, are not available for a title. Use one-byte alphanumerical characters.	Event1
Alarm 1 Action	Select the mode of the alarm to be effective when an alarm input signal (no-voltage make contact) is input to alarm input/output terminal (six-pin connector (black)) pin 1 “ALARM IN1 (blue).” None: No action will take place. Send FTP: The JPEG file of the obtained snapshot will be transmitted by FTP. Send E-Mail: E-mail will be transmitted. Both: The JPEG file of the obtained snapshot will be transmitted by FTP and e-mail will be transmitted at the same time.	None
Matched Resolution (Alarm 1)	Designate the size of JPEG images to be attached when transmitting the FTP or transmitting e-mail as set at Alarm 1 Action. Half-D1/SIF/QQVGA	SIF
Alarm 2 Title	Set any desired title of alarm 2. *Two-byte characters, including Japanese characters, are not available for a title. Use one-byte alphanumerical characters.	Event2
Alarm 2 Action	Select the mode of the alarm to be effective when an alarm input signal (no-voltage make contact) is input to alarm input/output terminal (six-pin connector (black)) pin 3 “ALARM IN2 (gray).” None: No action will take place. Send FTP: The JPEG file of the obtained snapshot will be transferred by FTP. Send E-Mail: E-mail will be transmitted. Both: The JPEG file of the obtained snapshot will be transferred by FTP and e-mail will be transmitted at the same time.	None

● Alarm

Name	Function	Factory settings
Matched Resolution (Alarm 2)	Designate the size of JPEG images to be attached when transmitting the FTP or transmitting e-mail as set at Alarm 2 Action. Half-D1/SIF/QQVGA	SIF
Motion Detection Title	Set any desired title of Motion Detection. Two-byte characters, including Japanese characters, are not available for a title. Use one-byte alphanumerical characters.	Motion Detection
Motion Detection Action	Select an alarm action to take place when an action is detected under the action detection settings made on Viewer. None: No action will take place. Send FTP: The JPEG file of the obtained snapshot will be transmitted by FTP. Send E-Mail: E-mail will be transmitted. Both: The JPEG file of the obtained snapshot will be transmitted by FTP and e-mail will be transmitted at the same time.	None
Matched Resolution (Motion Detection)	Designate the size of JPEG images to be attached when transmitting the FTP or transmitting e-mail as set at Motion Detection Action. Half-D1/SIF/QQVGA	SIF
Alarm 1 Output	An alarm output signal (open collector output) will be output to alarm input/output terminal (six-pin connector (black)) pin 5 "ALARM OUT (black)" when alarm 1 is activated.	None
Alarm 2 Output	An alarm output signal (open collector output) will be output to alarm input/output terminal (six-pin connector (black)) pin 5 "ALARM OUT (black)" when alarm 2 is activated.	None
Motion Detection Alarm Out	An alarm output signal (open collector output) will be output to alarm input/output terminal (six-pin connector (black)) pin 5 "ALARM OUT (black)" when a motion is detected.	None

● E-mail

Name	Function	Factory settings
E-mail	Designate the address to which e-mail will be transmitted.	None
E-mail from	Designate the e-mail address of the Camera.	None
E-mail CC1 / CC2 / CC3	Designate an address to which e-mail will be transmitted at the same time when it is sent to the e-mail address set at To.	None
SMTP	Designate the SMTP server to be used.	None
Use Authentication	Designate whether to use user authentication on the SMTP server to be used.	None
POP before SMTP	Designate whether to use POP before SMTP on the SMTP server to be used.	None
User ID	Set a login ID for logging in to the SMTP server.	None
User PW	Set a password for logging in to the SMTP server.	None
Message	Set a text to be sent as a message when transmitting e-mail.	None
Action	<p>Text Only: Only a text will be sent when e-mail is transmitted.</p> <p>Picture Only: Only an image will be sent when e-mail is transmitted.</p> <p>Both: Both a text and an image will be sent when e-mails transmitted.</p>	Both

● FTP

Name	Function	Factory settings
IP address	Designate the IP address of the server to which the FTP will be transferred.	0.0.0.0
Port number	Designate the port number of the FTP server to which the FTP will be transferred. It is not generally necessary to change the setting.	21
User ID name	Designate an account name for connection to the server to which the FTP will be transmitted.	None
User Password	Designate a password for the account name shown above.	None
Directory	Designate a directory for saving an image file, or a directory with a write authority for the designated account name.	None
Passive Mode	Designate whether to use passive mode or active mode for transmitting the FTP. Use passive mode when there are restrictions on the ports because of a firewall, etc.	None
Time Store	Set whether to regularly save images in the FTP server.	None
Time Store login each send	Set whether to connect to the FTP server each time images are transmitted or not (always connected).	None
Time Store dwell time (seconds)	Set the interval at which images will be saved when Time Store is valid (30 to 180 seconds).	30
Image size	Designate the size of images to be saved. Half-D1: 704 × 240 SIF: 352 × 240 QQVGA: 160 × 120	SIF
Time Store filename	Designate a file name for the file to be saved. A file name consists of the “entered file name” and “time.” The extension “.jpg” will be added automatically to each file name. If a file with the same name already exists in the directory for saving, the data of the older file will be overwritten. Designate a different file name.	ptc401cip

● User

Name	Function	Factory settings
User list	Registered login IDs and authorities are displayed.	root,Admin
Adding a new user	<p>You can register a login ID, a password, and authority for connection to the Camera. Designate one of the following authorities, and enter a login ID and a password.</p> <p>Administrator: The login ID for the administrator. The login ID is “root” that is unchangeable. With this ID, you can view images, operate the Camera, and make settings.</p> <p>Operator: You can view images and operate the Camera.</p> <p>User: You can only view images.</p> <p>* You can use up to 16 one-byte characters for a name, including alphanumerical characters and upper-case and lower-case alphabetic characters.</p>	
Modifying a user	<p>You can modify the registered login ID, password, and authority of any user for connection to the Camera. Designate one of the following authorities, and correct the login ID or password.</p> <p>Administrator: The login ID for the administrator. The login ID is “root” that is unchangeable. With this ID, you can view images, operate the Camera, and make settings.</p> <p>Operator: You can view images and operate the Camera.</p> <p>User: You can only view images.</p> <p>* You can use up to 16 one-byte characters for a name, including alphanumerical characters and upper-case and lower-case alphabetic characters.</p>	
Deleting a user	You can delete the registered login ID, password, and authority of any user for connection to the Camera.	

● IP Filtering

Name	Function	Factory settings
Start IP End IP	Set in the Exception list IP addresses whose access to the Camera will not be permitted or rejected. Example: When Start IP is 192.168.1.50 and End IP is 192.168.1.100 All addresses between them will be set.	0.0.0.0
Add	Adds all addresses between the addresses set at Start IP and End IP to the list.	(None)
Modify	Modifies addresses selected in the Exception list.	(None)
Remove	Deletes selected addresses in the list.	(None)
IP Filter	Select whether to use the IP filtering function.	None
Accept all	Permits access from all IP addresses except those in the range of addresses set in the Exception list.	Effective
Reject all	Rejects access from all IP addresses except those in the range of addresses set in the Exception list.	Invalidity

● Camera Control

Name	Function	Factory settings
Camera Policy	All-Time Share: The control policy remains unless the client having an operation authority cuts off the connection. Time Slice Share: The operation authority will be released as soon as the time set at “Control Duration Time” passes away, and will be assigned to another connecting client. It will remain when there is no other connecting client.	Time Slice Share
Control Duration Time	Designate the period during which a client maintains control when “Time Slice Share” is selected at “Control Policy” (setting range: 1 to 60 minutes).	1 minute
User Authentication	Select whether to authenticate access from the Web browser and from Viewer.	Enable

● Motion Detection Setup (for ELMO 1Channel Viewer only)

Name	Function	Factory settings
Use Motion Detection	Used to set whether to use motion detection.	No
Motion Detection Ignore Time After PTZ	Set a period for which motion detection is prevented after the Camera performs PAN/TILT/ZOOM when the motion detection function is enabled and a detection area is set. * This function prevents the operation of the automatic iris function from being detected as a motion after PAN/TILT/ZOOM.	3
Sensitivity	Set the sensitivity of motion detection. High – (adjustable using the scroll bar) – Low	High
Set/Clear	Used to select Set or Clear. Set: Sets the area dragged on the screen as a detection area. Clear: Sets the area dragged on the screen as a non-detection area.	Set
Detection Area	Detect: Hatching display enabled Not Detect: Hatching display disabled	(None)
Reset	Sets all areas on the screen as non-detection areas.	(None)
Select All	Sets all areas on the screen as detection areas.	(None)
Reverse	Reverses set detection and non-detection areas.	(None)
Apply	Applies area settings.	(None)

● Select Language (for ELMO 1Channel Viewer only)

Name	Function	Factory settings
Select Program Language	Japanese/English	None
System Time	Used to set the current date and time of the Camera.	(none)

12. TROUBLESHOOTING HINTS

Symptom	Checking Point	Ref. Page
No image or dark image on the monitor	Is the Camera main unit connected correctly with the monitor with the video cable? Isn't the MONITOR IN terminal of the monitor wrong?	P. 15
	Is the power cord connected correctly to the outlet?	P. 15
	Is the plug of the AC adapter connected correctly to the DC jack on the Camera?	P. 15
	Aren't the power cord, the AC adapter cord, and the video cable damaged, broken or contacted incompletely?	P. 15
	Is the correct voltage (100-240V AC) supplied to the power outlet? Isn't the breaker active?	P. 15
	Is the iris in proper position?	P. 18
	Isn't the zoom on the TELE side and imaging a dark, monochromatic object?	P. 17
	Isn't the LED lighting in red? If yes, the Camera power should be OFF.	P. 16
	Isn't the OFF TIME function activated, turning OFF the Camera power? (If the Camera power is turned ON without being aware of this and the no-operation status continues, the Camera power will be turned OFF again.)	P. 16, 22
	Is the high-speed shutter set?	P. 23
	Isn't the monitor TV system different from the signal of this Camera (NTSC)?	
	Out of auto focus	Isn't mode the Manual Setting mode? If yes, press the AUTO button to return the mode to the Auto Focus mode.
Isn't the auto focus taking an object with less contrast or a fast moving object? (There are some objects that are difficult for the auto focus to trace.)		P. 18
Isn't the infrared illumination intensive? Set [CAMERA1] – [INFRARED] to [ON] in the OSD menu.		P. 23

Symptom	Checking Point	Ref. Page
No operation via wireless remote controller	Isn't wrong ID number set?	P. 20
	Check the remaining battery power of the wireless remote controller.	P. 9
	If the sunlight or the fluorescent lamp light of the inverter enters the infrared sensor, the signal from the wireless remote controller could not be sensed normally. If yes, block the light, and then operate the wireless remote controller.	P. 9
	Isn't the 4P DIP switch No. 1 located on the bottom of the main unit set to [ON]? If yes, the wireless remote controller cannot be operated.	P. 30
	Isn't [PAN TILT] – [PRESET STILL] set to [ON] in the OSD menu? If yes, the PAN-TILT-ZOOM operation is disabled.	P. 27
B&W image	This Camera has the B&W/color switching function. Check the settings.	P. 23
No switching to B&W image	Isn't [CAMERA1] – [ICR] set to [OFF] in the OSD menu? If yes, the DAY/NIGHT function is disabled.	P. 23
Frequent color/B&W screen switching	Isn't the infrared illumination intensive? Increase the numeric of [CAMERA1] – [AUTO LEVEL] in the OSD menu.	P. 23
Shimmer when imaging fluorescent lamp	When [CAMERA1] – [HS-SHUTTER] is set to [OFF] in the OSD menu, the shimmer will be eased by setting the shutter speed to [1/100s]. (However, since this will change the brightness, the iris operation may be required.)	P. 23
No adjustment of preset position	The Camera head direction may have been changed by hand. Correct the position by pressing the RESET button on the wireless remote controller.	P. 17

Symptom	Checking Point	Ref. Page
The network function does not work.	<p>Recheck the Camera and the network configuration of the PC connected to it, and check them for the phenomena described below.</p> <p>Recheck the restraints on the Camera, including the number of connections, and the settings as well.</p>	P. 33
The operation of the network is unstable.	<ul style="list-style-type: none"> • The network operates only in the environment shown below when it is connected to the Web: <ol style="list-style-type: none"> 1. The OS is Microsoft Windows 2000 or XP. 2. JRE 1.5.0 or a later version is installed. 3. Java (Sun) is enabled. <p>“ELMO 1Channel Viewer” operates only in the environment shown below.</p> <ol style="list-style-type: none"> 1. The OS is Microsoft Windows 2000 or XP. 2. DirectX 9.0C or a later version is installed. 	P. 33
The LAN cable cannot be connected.	The LAN connector (RJ45) is provided in the back of the Camera.	P. 7
The LAN connector link indicator lamp does not light.	<ul style="list-style-type: none"> • The power to the Camera or a device connected to it is not turned ON. Confirm that the cable is connected securely, and turn ON the power. 	
	<ul style="list-style-type: none"> • The network address set on the Camera and that of the network to which the Camera is connected do not match. If the initial setting for the Camera is not changed and the network address is 192.168.1.*, the link indicator lamp lights only when a computer whose set IP address is 192.168.1.* (except 192.168.1.10) is connected to it using the LAN cable. 	
	<ul style="list-style-type: none"> • The LAN cable is broken. Check if continuity appears across cable connector terminals. 	
	<ul style="list-style-type: none"> • A wrong cable is used. Basically, use a “LAN cross cable (supplied)” when a PC is connected to the Camera, or a “straight cable” when a hub or router is used. Check the specifications of the device to be connected. 	P. 34, 35

Symptom	Checking Point	Ref. Page
The PC cannot be connected to the Camera.	<ul style="list-style-type: none"> The IP address of the Camera is not designated. Designate the IP address set in the Camera. 	P. 38 48,66 73
	<ul style="list-style-type: none"> The IP address set on the PC does not match the network. The connection from a client to the Camera requires the network address to be the same (192.168.1.* when the Camera is in the initial setting). 	P. 34 35
	<ul style="list-style-type: none"> The setting for the router is not correct. Check the network configuration of the Camera and PC, and set the router correctly. * If you have forgotten the IP address of the Camera, see "Returning the Camera to the initial state (page 32)." 	P. 34 35
The Camera cannot be logged in from the Web browser.	<ul style="list-style-type: none"> The login ID and password set on the Camera are not entered. Enter the login ID and password set on the Camera. * If you have forgotten the login ID or password set on the Camera, see "[1] Initializing the setting (page 32)." 	P. 38 54,55 80,81 90
"ELMO 1Channel Viewer" cannot be logged in.	<ul style="list-style-type: none"> The viewer ID and password set on "ELMO 1Channel Viewer" are not designated. Enter the login ID and password set on "ELMO 1Channel Viewer." * If you have forgotten the login ID or password set on "ELMO 1Channel Viewer," reinstall the program according to "[2] Install (page 36)," and set a login ID and a password when it is first run. 	P. 65 66,90
The Camera cannot be logged in from "ELMO 1Channel Viewer."	<ul style="list-style-type: none"> The login ID and password set on the Camera are not designated. Enter the login ID and password set on the Camera. * If you have forgotten the login ID or password set on the Camera, see "[1] Initializing the setting (page 32)." 	P. 38 54,55 80,81 90
The Camera cannot be operated.	<ul style="list-style-type: none"> It is logged in with the authority "user." Log in with the authority "administrator" or "operator." 	P. 38 65
A setting page cannot be accessed.	<ul style="list-style-type: none"> It is logged in with the authority "user" or "operator." Log in with the authority "administrator." 	P. 38 65

If the problem still remains after checking the above and apply the remedy, consult our dealer from whom you have purchased the Camera or our branch office or sales office nearest to you.

13. SPECIFICATIONS

Note: The specifications are subject to change without notice.

● General

Item	Specifications		
Power source	DC12V (DC11V-16V)		
Current consumption	MAX. 1A		
Outside dimensions	Diameter 142mm (5.74in.), Height 153mm (4.76in.) (Projections and fitting plate not included)		
Weight / mass	1200g (2.6416) (Fitting plate included)		
Television system	NTSC		
Video signal output terminal	Composite video	BNC jack / 75Ω unbalanced	1
External control terminal	RS-485	5P connector (white)	1
	ALARM IN-OUT	6P connector (black)	1
Audio input	3.5mm monaural mini-Jack		
Audio output	RCA pin Jack		

● Lens

Item	Specifications
Optical zoom	Powered 12 times
Focal length	F = 3.8 – 45.6mm
F No.	F1.6 – 2.7
Field of view (horizontal)	4.5° – 52.8°
Iris	Auto (OPEN / CLOSE / NORMAL)
Focus adjustment	Full-auto / Manual

● PAN-TILT

Item	Specifications
PAN range	Left 175°, Right 175°
TILT range	Up 15°, Down 195°
PAN-TILT speed	Auto / Manual (8 speeds)
Preset point	16 points
Auto return to home position	Provided
Pan / Tilt movable range limit	Provided (Setting enabled when dome cover is mounted)

● Camera

Item	Specifications
Image pickup device	1/4-in CCD
Effective picture element	768 (Horizontal) × 494 (Vertical)
Total picture element	811 (Horizontal) × 508 (Vertical) (410,000 pixels)
Minimum illumination (Note)	Color: 1 lx (DAY/NIGHT function OFF, 30IRE) B&W: 0.3 lx (DAY/NIGHT function ON, 30IRE)
Digital zoom	Max. 16 times
Backlight compensation	ON/OFF
White balance	Auto / One-push / Manual / Indoor mode / /Outdoor mode / Fluorescent lamp mode
Sync. system	Internal sync
Resolution	Horizontal: 470 TV lines or more Vertical: 360 TV lines or more
S/N ratio	49dB
DAY/NIGHT function	Provided
Masking function	Provided
Image flip (vertical, horizontal) function	Provided
AGC gain adjustment	Provided
Detail compensation level adjustment	Provided
High-speed shutter	Provided (1/60s – 1/50000s)
Low-speed shutter (Electronic sensitivity up)	Provided (Max. 80 fields)

Note: Measured in flat lamp light. The numeric value depends on the light source.

● Network

Item	Description
Interface	10Base-T/100Base-TX (automatic switching)
Compatible protocol	IP, ARP, ICMP, TCP, UDP, HTTP, FTP, SMTP
IP filtering	IP filtering Function (Packet filtering by connection source IP address/network address)
Web server functions	
Compatible browser	Internet Explorer 6.0 or later version
Compatible OS	Windows 2000/XP
Number of ports	TCP 80, 1024 to 65535 (changeable)
User authentication	BASIC authentication (enabled/disabled switchable)
Number of registrable accounts	100 (Administrator, operator, and viewer authorities can be set for each account.)
Language	Japanese, English
Live image display	
Image format	Motion-JPEG
Image size	Half-D1(704×240)/SIF(352×240)/QQVGA(160×120), simultaneous distribution possible.
Frame rate	Up to 30 fps (when SIF is selected). The rate is variable dynamically according to the bandwidth.
Image quality setting function	Three levels
Number of simultaneous logins	50 clients
Compatibility with sound	Image asynchronous (enabled/disabled switchable)
Snapshot display	
Image format	JPEG
Image size	Half-D1(704×240)/SIF(352×240)/QQVGA(160×120), simultaneous distribution possible.
Remote operation	
Pan/Tilt	Designate an absolute value using the scroll bar or on the position panel. The current position will be displayed.
Zoom	Designate an absolute value using the scroll bar or on the position panel. The current position will be displayed.
Iris	Move at constant value (Close/Open), NORMAL
Focus	Move at constant value, automatic
Preset	Move, setting
Home	Move
Reset	PAN/TILT/ZOOM position initialization
Centering function	The position clicked on the screen will move to the center.
General-purpose output control	Provided
Control management	Time sharing (1 to 60 minutes, infinite) or normal is selectable.

Item	Description
Setting	
Set value import/export function	Provided (text data) (for Viewer only)
Firmware update function	Provided (for Viewer only)
Firmware version information display function	Provided (for Viewer only)
Stream server functions	
Transmission mode	Unicast/Multicast (switchable)
Live image display	
Compatible browser	Dedicated application
Compatible OS	Microsoft Windows 2000/XP
Image format	MPEG4
Image size	D1 (704×480) / SIF (352×240)
Frame rate	30/15/10/5/1 fps (changeable according to setting)
Bandwidth limit function	Can be set between 64 kbps and 2 Mbps.
Number of simultaneous logins	Three clients (in Unicast)
Compatibility with sound	Image synchronization (enabled/disabled switchable)
Snapshot display	Snapshots can be displayed by using a Web server.
Motion detection	Provided
Remote operation	According to the Web server function.
Sound reproduction server function	Provided
FTP client functions	
Alarm transmission function	A JPEG image file of the designated size will be saved in the designated FTP server when an alarm is input or after the corresponding preset move takes place.
Periodical save function Select and use either of the abovementioned functions.	A JPEG image file of the designated size will be saved in the designated FTP server at the designated intervals. (For the control connection, "Maintain" or "Connect each time" can be selected.)
SMTP client functions	
Alarm transmission function	When an alarm is input, the input channel and the time of the alarm will be transmitted to the designated e-mail address. Transmits a JPEG image file of the designated size.
JPEG image attachment function	Half-D1, SIF, QQVGA or not attached can be selected.
Authentication	Compatible with POP before SMTP and SMTP-AUTH.

● Others

Item	Specifications
OSD Menu window	Provided (Camera setting)
Daisy chain connection (RS-485)	Max. 223 Cameras

14. SUPPLIED ACCESSORIES

Name	Quantity
AC adapter (AC120V 60Hz)	1
Power code	1
Wireless remote controller (RC-PTY)	1
Battery size AAA	2
RS-485, Relay cable (5P connector color: White)	1
ALARM IN-OUT, Relay cable (6P connector color: Black)	1
LAN cross cable	1
Ceiling plate	1
Main unit set screw M3 × 5	1
Fixing plate (for under the roof)	1
Fixing screw M4 × 40	4
Instruction Manual (CD-ROM)	1
Installation manual	1

Note: Weight and dimensions are approximate.

Note: Design and specification are subject to change without notice.

15. OPTIONS

Name
Clear dome cover PTC40CL
Smoke dome cover PTC40SM

~~ELMO~~ is a trademark of ELMO CO., LTD.

“Microsoft,” “Windows,” and “Internet Explorer” are registered trademarks of Microsoft Corporation of the U.S. in the U.S. and other countries.

Java is a trademark of Sun Microsystems, Inc.

All other companies and product names contained herein are each company’s trademarks or registered trademarks.

WARNING:

- Unauthorized recording of copyrighted, materials, photographs, etc. may infringe on the rights of copyright owners and be contrary to copyright laws.

ELMO CO., LTD.

6-14, Meizen-cho, Mizuho-ku,
Nagoya, 467-8567, Japan

OVERSEAS SUBSIDIARY COMPANIES

U.S.A

ELMO USA CORP.

1478 Old Country Road, Plainview, NY 11803-5034
Tel:(516)501-1400 Fax:(516)501-0429
E-mail:elmo@elmousa.com
Web : <http://www.elmousa.com>

Canada

ELMO CANADA CORP.

44 West Drive, Brampton, Ontario L6T 3T6
Tel:(905)453-7880 Fax:(905)453-2391
E-mail : info@elmocanada.com
Web : <http://www.elmocanada.com>

Germany

ELMO (Europe) G.m.b.H

Neanderstr. 18, 40233 Düsseldorf
Tel:(0211)3864-70 Fax:(0211)376630
E-mail : info@elmoeurope.com
Web : <http://www.elmoeurope.com>

Printed in Japan
6X1PTYN02