

ARITERM

INSTALLATION, OPERATION AND
MAINTENANCE

+Multijet 500-1500 hydraulic



TABLE OF CONTENTS:

FOR THE NEW OWNER	3
INFORMATION ABOUT THE BURNER	4
GENERAL	5
TRANSPORT, HANDLING AND STORAGE	6
MECHANICAL INSTALLATION	7-8
CONTENTS OF DELIVERY	9
INSTALLATION	10-15
INTRODUCTION INTO USE	16-17
OPERATION-RELATED RISKS AND WARNINGS	18
SERVICING	19
TROUBLESHOOTING	20-21
INSTRUCTIONS IN CASE OF EMERGENCY	22
TECHNICAL SPECIFICATIONS	23
HYDRAULIC SYSTEM	24
HYDRAULIC DIAGRAM	25-26
500 - 1500 kW DIMENSIONS	27
500 kW INTERNAL PARTS EXPLODED VIEW	28
500 kW SURFACE PARTS EXPLODED VIEW	29
700 kW INTERNAL PARTS EXPLODED VIEW	30
700 kW SURFACE PARTS EXPLODED VIEW	31
1000 kW INTERNAL PARTS EXPLODED VIEW	32
1000 kW SURFACE PARTS EXPLODED VIEW	33
1500 kW INTERNAL PARTS EXPLODED VIEW	34
1500 kW SURFACE PARTS EXPLODED VIEW	35
PROPERTIES OF BIO-FUELS	36
WARRANTY	37
DECLARATION OF COMFORMITY	38
NOTES	39-43

■ FOR THE NEW OWNER

In this guide, we have compiled the key facts on installation, operation and servicing. Ariterm Oy's bio-burners have been designed to be easy to operate and reliable, and risks such as burn back have been eliminated through the introduction of several safety systems. By observing the instructions in this guide, your burner will achieve optimal operation. The quality of fuel used also fundamentally affects the ease of use.

The model of burner and level of accessories are selected at the order stage to suit the needs of the customer. These instructions are a general guide to the Ariterm Multijet range of products. Because of this, there may be differences between the burner delivered to you and these instructions, due to different power ratings. During the installation stage, situations may emerge for which these instructions do not provide a direct answer.

■ INFORMATION ABOUT THE BURNER

Enter the burner's information into the table below. This will mean that we can act quickly for servicing and repair.

Write here the model of burner, serial number, date of purchase and date of installation.	
MODEL	
SERIAL NUMBER / YEAR	
DATE OF PURCHASE	
DATE OF INSTALLATION	
FUEL	
INSTALLATION ENGINEER / INSTALLATION COMPANY	

Ariterm's bio-burners meet the most up-to-date operational and safety standards for the burning of bio-fuels. The Multijet is a burner equipped with a moving grate which is installed in the burner compartment of the boiler's fire chamber. The burner grate is located entirely inside the fire chamber.

An automation system controls the burner by feeding it fuel and combustion air. The air is divided through separate fans into primary and secondary air, and the fuel is gasified in the burner's grate. The feed system may consist of one or more feed augers and a fuel storage. The augers and storage are selected according to the fuel being used. The movement of the grate can be separately adjusted to suit each kind of main fuel.

Between the augers in the multi-auger systems is a sensor, which monitors the fuel feed to the burner. If a moving floor storage unit is part of the equipment, the automation system also controls this. When using pellets as fuel, no special control is required for the silo.

The burner's automation system controls the equipment based on the boiler's water temperature which is measured by a PT-100 sensor (with 4...20 mA transmitter). With the Arimatic control unit (AM200, AM1000, AM2000 or AM3000), the burner can be maintained on constant partial power settings and reverts to its inactive mode only when the power requirement falls below the minimum level. In normal operation, the automation system runs the burner based on the power requirement at a level between 21% and 100%.

The equipment must have burn back protection. Such equipment varies depending on the fuel and feed system selected. Please note that the fuel selected also affects other parts of the equipment.

ALWAYS CHECK WITH THE PRODUCT SUPPLIER ON THE SUITABILITY OF THE FUEL FOR YOUR BURNER!

■ TRANSPORT, HANDLING AND STORAGE

The burner is packed at the factory for transportation and short-term storage. Depending on the means of transport and place of storage, however, the package may require additional protection to ward off moisture, knocks, etc.

The burner is often part of a larger entity. If you are transporting the system by itself, in order to avoid transport damage and for the sake of traffic safety it is important to tie the packages together as well as possible and to secure them to the vehicle. The transport company is always responsible for the correct loading and securing of the equipment.

Use caution when handling components in order to prevent damage.

The equipment can be stored in the open air if protected from rain and ground moisture. Long-term storage, however, requires a better storage location. Storage indoors is recommended as the equipment contains sensitive parts such as electric motors, sensors and a control unit.

■ MECHANICAL INSTALLATION

■ Receiving delivery and handling

When you receive the delivery, check that the contents correspond to your order and that the final inspection report and list of accessories are included. If anything is unclear, contact the seller immediately.

Before commencing assembly, it is advisable to read not only these burner installation and operating instructions carefully but also the installation instructions for the boiler, automation system and fuel storage.

This way you can ensure beforehand that the main facts and measurements are all satisfactory for a successful installation. Please note: Keep all operating and installation instructions in a safe place where you can easily find them when you need them, for example in their own folder in the boiler room.

The parts of the Arterm bio-heating system should always be installed by an expert and in accordance with requirements. We recommend that you carry out installation in the following order:

1. Put the boiler in position with the burner attached, and ensure that the pipes and flue are not yet connected.
2. Put the moving floor or other fuel storage unit in position.
3. Fit the augers between the storage and burner.
4. It is advisable not to carry out the final precise positioning of the boiler and fuel storage until the suitability of the augers has been checked. In the TPYM storage system, the discharger is fitted to the floor and is the checkpoint for the system.
5. Plumbing and electrical work is done last.

■ Requirements concerning the installation and operating environment

- The boiler room must be built in accordance with the relevant regulations (E9 Building Regulations, further information available from your local fire authority)
- Air vent in the boiler room wall. Recommended surface area $5 \text{ cm}^2 / 1 \text{ kW}$
- Installation and operating temperature $0 - +40 \text{ }^\circ\text{C}$
- The humidity of the boiler room should be $20 - 80 \%$ (in order to prevent condensation)

■ Necessary connections

- Electrical supply through the control unit to the actuators and instrumentation
- Flue in accordance with the instructions for the boiler to be used. Remember that the correct underpressure is important for the system to function properly!
- Water for the automatic extinguishing system (a powder extinguishing system is recommended if pellets are used as fuel)
- Installation of the storage discharger hydraulics
- Connecting the hoses of the hydraulic unit that move the grates of the Multijet burner to the burner's cylinders

■ Space requirement

Please note that there must be sufficient space for the burner and burner auger between the boiler and boiler room wall. When planning, it is advisable to make allowance for the possible dismantling of the burner and burner auger/motor for maintenance purposes (e.g. door openings). We recommend a distance of at least 1 metre between the boiler and the wall on the sides where sweeping and maintenance work will be carried out.

■ MECHANICAL INSTALLATION

The system delivery usually also includes a boiler, burner auger, auger motor, automation system and storage. These are selected based on the type of fuel and fuel storage being used.

■ Installing the burner in the boiler

The burner can be installed in a solid fuel boiler, the power rating of which corresponds to the power of the burner. The underpressure required for the reliable and correct operation of the burner (25-30 pa in the fire chamber) can be ensured either by a correctly dimensioned chimney or an underpressure-controlled flue gas extractor.

We recommend that compatibility with anything other than an Ariterm boiler is checked by the burner manufacturer.

The burner is fixed by its flange to the boiler with bolts and the seam is sealed with heat-resistant silicone (1). The joints must be sealed so well that they are completely air-tight! The bolts are tightened diagonally. If the boiler opening and burner flange are of different sizes, for the purposes of installation, a suitable installation flange must be made.

■ CONTENTS OF DELIVERY

Nr.	Part (delivered with burner)	Power			
		500	700	1000	1500
1	Multijet burner	1	1	1	1
2	Hexagonal screw M12x25 for burner fastening	18	22	22	22
3	Washer M12	18	22	22	22
4	Cleaning rake, rounded	1	1	1	1
5	Heat-resistant silicone, tube	1	1	1	1

Nr.	Part (installed to burner)		Power			
			500	700	1000	1500
1	Fan Sodeca CMP-512-2T, 3~, 0.08 kW	13370	4	-	-	-
2	Fan Sodeca CMP-514-2T, 3~, 0.18 kW	13346	-	4	-	-
3	Fan Sodeca CMP-616-2T, 3~, 0.37 kW	13372	-	-	5	6
4	Screw for fan fastening M6x20		16	16	20	24
5	Nut M6		16	16	20	24
6	Inductive sensor Omron E2A-M12KS04-WP-B1	13962	8	8	8	12
7	Hydraulic unit HTR 1030-PU05, 0,37 kW	17565	1	1	1	
8	Hydraulic unit HTR 1017-PU05 , 0,37 kW	17546				1

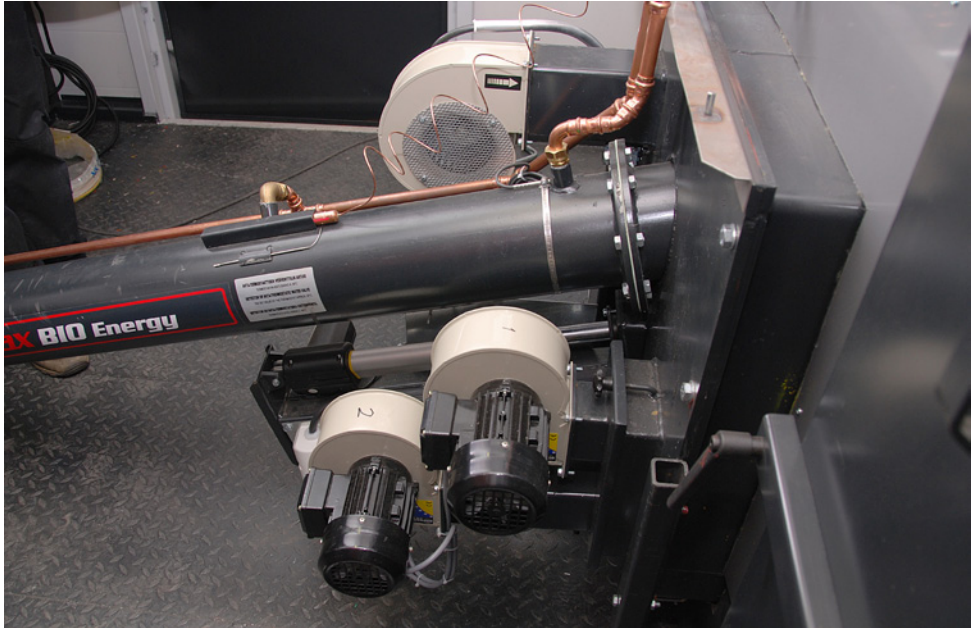

■ Installing the burner auger

1. After attaching the burner, the fireproof burner pipe is inserted into the burner's feed opening.
2. The feed auger is inserted into the burner pipe.
3. The burner auger pipe and gasket are installed into the burner auger with fastening bolts.
4. The depth of the feed auger is adjusted so that the head of the feed auger extends 0 to 10 mm past the level of the burner's back wall.
5. The seam between the burner tube and burner head is sealed with heat-resistant silicone from the outside.

■ INSTALLATION

■ Installation of other equipment

1. Four to six combustion air fans are ready installed on the burner, depending on its size. The attached table lists the models of different burners and the number of fans in each with data about their motors. For example, the Multijet 700 burner has two primary fans (Sodeca CMP-514-2T) and two secondary fans (Sodeca CMP-514-2T).
2. Moving the burner grate is operated hydraulically. The burners MJ500, MJ700 and MJ1000 have two hydraulic cylinders and the MJ1500 has three. For example, the MJ700 burner has one cylinder on top and one at the bottom. Each cylinder is equipped with four inductive limit switches. The system's logic controls the cylinders based on information from the switches. For more information on the installation and operations of the power unit, see the chapter "HYDRAULIC SYSTEM" (p.24).

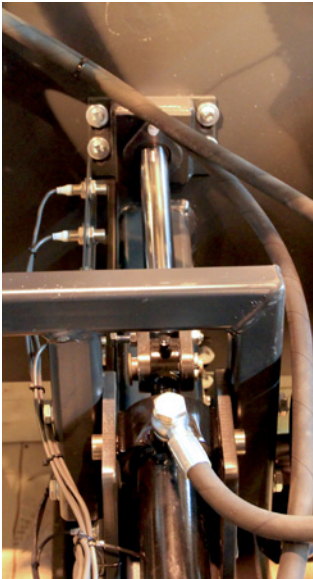

INSTALLATION

Electrical installation

The wiring diagrams for the burner's electrical equipment can be found in the automatic control unit instructions.

ELECTRICAL INSTALLATION MUST ONLY BE CARRIED OUT BY A QUALIFIED ELECTRICIAN!

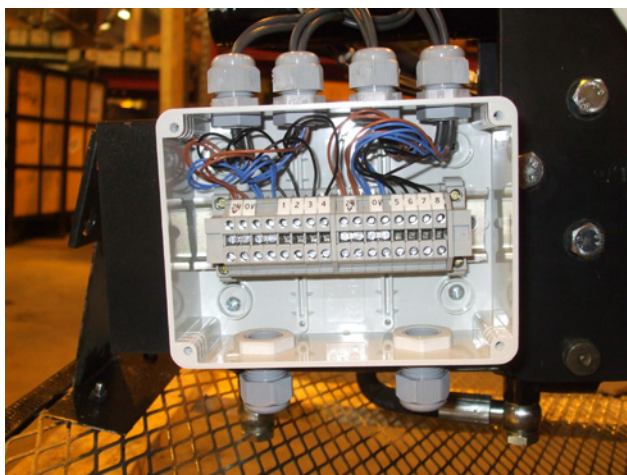
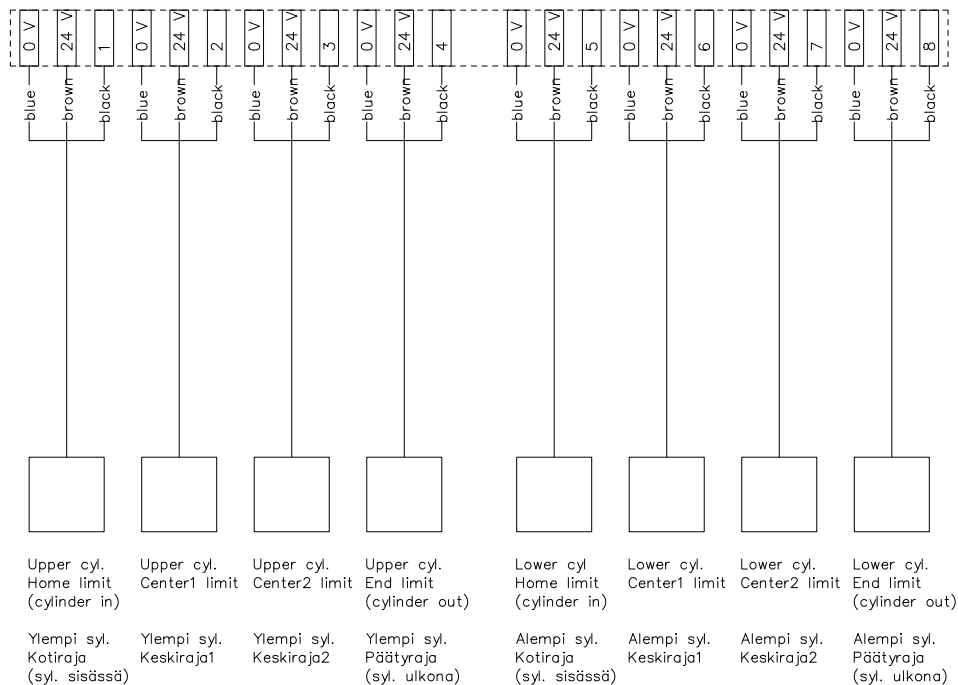

■ INSTALLATION

■ Powder extinguishing system

- The powder extinguishing system consists of a bottle (+ spare bottle), a valve, extinguishing hoses and a red plastic sensor pipe.
- Install the 3 hoses of the system between the powder extinguisher, auger pipe and intermediate tank units.
- Install the red sensor pipe in the powder extinguisher unit and tighten it. Install the other end of the pipe under the visor located on the auger pipe surface (see figure).
- PLEASE NOTE! Open the extinguishing bottle slowly and in several stages to ensure the even distribution of the sensor pipe gas pressure and prevent the content of the bottle from being discharged by accident.
- When heated, the pipe melts and breaks. This releases the pressure that keeps the extinguishing bottle valve closed. The sensor pipe can be used again after cutting off the melted part. Install the sealing plug again.
- PLEASE NOTE! The powder extinguishing system is an accessory. When using pellets as fuel, it is recommended to replace the water extinguishing system with a powder extinguishing system.
- Install the red hose filled with gas so that, when overheated, it melts and discharges the powder extinguishing device. The powder penetrates into the burner auger and puts out the fire.
- The bottles must be replaced and refilled during factory maintenance.

■ Installation of safety systems guarding against burn back

The Arterm bio-burner must be equipped with an extinguishing system to prevent burn back. To ensure safe use of the equipment, it is important to install all extinguishing systems before the equipment is started.

If the burner has two feed augers (MJ700-1500), separate safety equipment must be installed in both feed augers.

The extinguishing systems are as follows (a-d):

a. Connecting the AVTA safety valve to the water supply system (wood chip-burning systems)

- The Danfoss AVTA15 (50–+90 °C) thermostat valve (1) is connected to the burner auger pipe and intermediate tank. The valve sensor is manually pushed above the sensor pocket (2) (see picture), and the valve is connected to the water supply system. In order to avoid possible network pressure loss, you can fit an expansion tank (4) equipped with a non-return valve and a pressure warning gauge (PIA).
- Through manual override, the water can be sprayed into the fuel system manually.
- The AVTA valve must be adjusted to about 80 °C (on scale no. 4).

Please pay attention to the installation instructions for the valve sensor!

- The burn back thermostat sensor and AVTA valve sensor are each installed in their own sensor pocket on the surface of the auger pipe. Please note that the sensors must be tight against the auger pipe housing. If necessary, use heat-conducting material or screws. The screws must not, however, damage the sensor! The burn back thermostat is connected to the burner's automation system. The AVTA operates on water pressure.

■ INSTALLATION

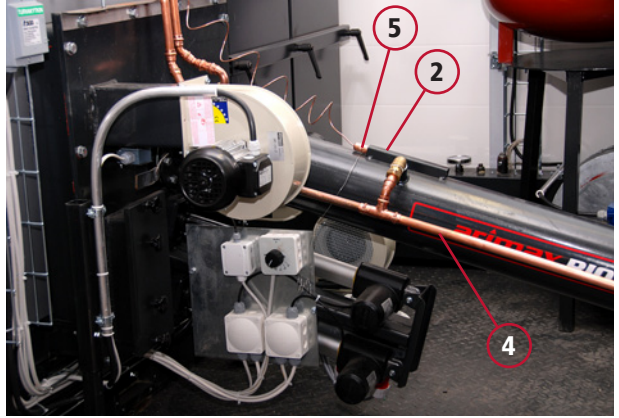
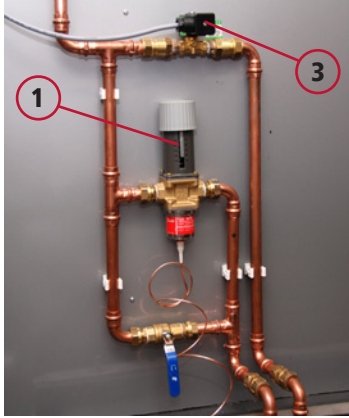

b Pulse-controlled extinguishing system connected to the water supply system

- ✦ The magnetic valve pipe (5) is connected to the feed auger pipe. The valve is controlled by the Arimatic automatic control system. The pulse-controlled burn back protector is adjusted to a temperature of 60 – 70°C, where it operates before the AVTA valve. THE SETTINGS FOR THE PULSE EXTINGUISHING CAN BE FOUND FROM THE AUTOMATION SYSTEM OPERATING INSTRUCTIONS!.
- ✦ The operation of the magnetic valve during power cuts can be ensured using UPS equipment.
- ✦ Possible loss of supply pressure can be avoided by installing an expansion tank and pressure warning gauge (PIA).
- ✦ The sensor of the pulse-controlled burn back system is installed close to the burner head so that it is tripped first.
- ✦ The pulse-controlled burn back system is no substitute for an AVTA or powder extinguishing system!

■ INSTALLATION

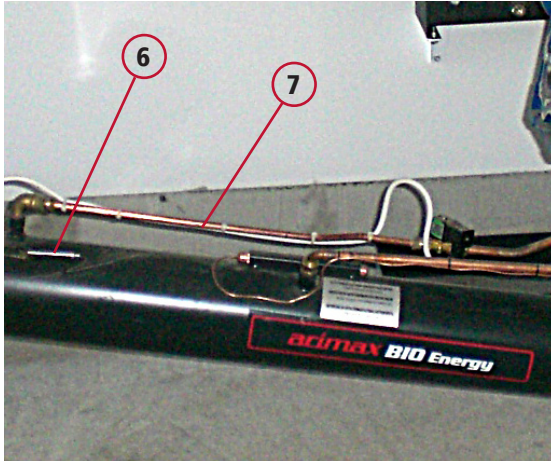

PLEASE NOTE! We recommend that water-powered extinguishing systems are fitted with a 50-litre membrane expansion tank (RST), non-return valve and pressure warning gauge. This means that a possible drop in supply pressure does not jeopardise the operation of the safety equipment.

c. Burn back thermostat

- The burn back thermostat sensor is installed in the burner auger pipe, under the visor beside the AVTA sensor. In a burn back situation, the automated system shuts off the combustion air fans and stops all operations in the storage. The fuel in the burner auger is driven to the burner head. After this, the burner auger also stops. The automation system maintains flue gas extractor operation. Adjustment range 60-70 °C.

d. Other safety systems

- A shut-off valve is fitted from the water supply system through which the user may draw water manually into the feed auger and hopper.

4. AVTA system extinguishing pipe
5. AVTA system temperature sensor
6. Pulse-controlled system temperature sensor
7. Pulse-controlled system extinguishing pipe

■ INTRODUCTION INTO USE

■ INTRODUCTION INTO USE

Operational testing

The operation of the equipment is tested before use as follows:

Start the motors (augers and fans) one at a time and check the following:

- directions of rotation of the augers
- operation and direction of rotation of the combustion air fans and flue gas extractor
- countermanding of fuel augers
- pump operation
- check the direction of rotation of the pump of the power unit
- operation of moving grate

Check the safety equipment

- Adjust the tripping temperature of the burn back thermostat to a level low enough to set off an alarm.
- Turn the thermostat of the AVTA valve so that it trips and check that the nozzles are open. Please note that this may create a large volume of water, and we recommend that you direct it into a separate receptacle.
- Adjust the tripping temperature of the pulse-controlled burn back thermostat to a level low enough that it trips.
- If necessary, carefully heat the sensors.
- Check the over-heat protection, boil-dry protector and other connected safety equipment.
- Check the alarm function and that a remote alarm is set off, if it has been connected

Read the operating instructions for the automatic control system before starting the system!

Adjustment

The burner and boiler should be run slowly up to operating temperature in order to minimise the heat stress on the structures. Automatic control should be shut off and a suitably low power level selected while the temperature is rising (about 1 hour).

Once the burner and boiler have been warmed up, the burner must be adjusted for clean and economic operation. An experienced burner operator can adjust the burner visually. The flame must be pale yellow and combustion must be even. Precise adjustment, however, requires the use of a flue gas analyser and this is recommended.

The excessive movement of fuel in the grate can be reduced by restricting the movement of the grate. If ash sticks to the grate, increase its movement.

Target values for combustion	
Oxygen (O ₂)	7-9%
Carbon monoxide (CO)	100-400 ppm, chip
Carbon monoxide (CO)	50-200 ppm, pellet

■ INTRODUCTION INTO USE

The temperature of the flue gas does not have a direct impact on combustion, but it has a significant impact on overall efficiency. At low power settings, the fan power must be sufficiently great to ensure that the burner's air ducts stay clean. The above-mentioned guidance values can then be exceeded.

The quantity and consistency of the ash is a good indication of the cleanliness of combustion. A large amount of ash or ash mixed with unburned substances is a sign of impure combustion.

PLEASE NOTE! The quantity of ash can fluctuate up to ten times depending on the fuel selected!

The lower burner fan acts as a primary air fan. Adjusting the primary air adjusts the power of the burner. Fine adjustment of the secondary air fan adjusts combustion. Burners of 150 kW or more have two primary air fans.

PLEASE NOTE! Any changes to the settings will take at least a couple of minutes to take effect.

Adjustment tips

- If too much unburned fuel has accumulated on the grate and/or in the ash, the feed rate of fuel to the burner auger should be cut and/or the fan revolutions increased. The movement of the grate should be shortened.
- If the tip of the flame is black and the boiler is getting dirty quickly, the secondary fan revolutions should be increased and/or the fuel feed rate cut.
- If the flame is bluish and burns unevenly, the secondary fan revolutions should be reduced.
- If the fuel includes lightweight particles, some of them may fly out of the burner with airflow before the fuel has burned completely. This is evidenced by sparks in the fire chamber and increased ash production. Some of this fly-out can be avoided by reducing the air flow (fans).
- When the fuel or its consistency changes, the settings must be readjusted.
- At low power settings, depending on the fuel being used, it is possible to ventilate the combustion air openings in the burner and prevent them from clogging. In that case, the adjustment value of the primary air blower must be raised, then the increased airflow keeps the holes open.

Please note! For the adjustments to be made, the equipment should be run with an almost full load. An under-loaded boiler reaches its set temperature quickly and the burner moves into an inactive stage, so the time required for adjustment can easily be too short. If the boiler is introduced into use in the summer (under-loaded), it should be re-adjusted as soon as it can be properly loaded.

Burner shutdown

The fuel in the burner, burner auger and intermediate tank must be burned away before the device is shut down. The shutdown function in Arimatic automatic systems can be activated from the USE menu. This function stops the operations of the storage auger and storage discharger (if in use). Other functions of the system continue to work normally and will stop at the flame control alarm when the fuel in the burner auger and hopper has burned out.

PLEASE NOTE! Ensure that the fuel is completely extinguished before you leave!

■ OPERATION-RELATED RISKS AND WARNINGS

■ Information about risks concerning operation

In a burn back situation, the fire has spread from the burner to the burner auger. Preventive measures:

- The fire chamber of the boiler must constantly have sufficient underpressure, even during combustion
- The automatic extinguishing systems must always be kept in operating condition
- This risk can be minimised in design by making the burner auger sufficiently long for the safety systems to have time to trip in a burn back situation
- A short (< 1,000 mm) burner auger requires a fire-resistant fan-wheel lift for permanent burn back protection.
- Fill the fuel tank in good time before the fuel runs out, so that the airflow cannot be sent off in the wrong direction.
- This solid fuel heating unit always generates heat, even when it is in inactive mode.
- Do not keep the unit running, if there is insufficient need for heat.
- A risky situation develops when the unit is kept running when it is under-loaded: **these risks include burn back, corrosion of the boiler and reduced efficiency.**
- Before you open the boiler hatches or begin servicing the boiler, switch off the automatic sweeping!
- Use hearing protection!
- Do not open the boiler hatches during a power failure. Danger of carbon monoxide explosion!
- Check whether there is a healthy flame in the burner before opening the hatches. If not, air the boiler by raising the revolutions of the flue gas extractor for about two minutes prior to opening the hatches.

■ Injuries caused by power transmission or fuel storage moving parts

Preventive measures:

- Always keep the covers of mechanical moving parts in place during operation.
- Always turn the power off at the mains before carrying out servicing on the equipment.
- Do not open the fuel tank when the equipment is running.
- Safety switches must be installed in motors, pumps and fans. PLEASE NOTE! EMC safety switches must be used in frequency converter-controlled motors!

■ Exposure to harmful dust

Preventive measures:

- Do not use wood chip that has gone mouldy.
- Re-fill the tank in good time before the fuel runs out
- Use a breathing mask.

WARNINGS!

- Do not enter an unventilated fuel storage. The enclosed space can be oxygen-free and so highly dangerous. Do not work alone in the fuel storage.
- BEWARE OF THE HOT BURNER SURFACES! The burner is insulated, but certain steel parts are connected to the burner flange and so may be hot.
- THE SAFETY SWITCH MUST BE LOCKED OPEN DURING MAINTENANCE WORK!!
- THE EQUIPMENT MUST NOT BE USED UNTIL IT HAS BEEN FULLY INSTALLED, THE SAFETY EQUIPMENT HAS BEEN TESTED AND CERTIFIED AS FUNCTIONAL, AND THE OPERATOR HAS BEEN TRAINED IN ITS USE AND UNDERSTANDS HOW TO OPERATE IT CORRECTLY.
- THE EMERGENCY STOP BUTTON DOES NOT STOP THE FLUE GAS EXTRACTOR IN ARIMATIC AUTOMATIC SYSTEMS
- NEVER INSERT YOUR HANDS INTO THE HOPPER HATCH – THE HOPPER'S LIMIT SWITCH DOES NOT STOP THE BURNER AUGER IN ARIMATIC AUTOMATIC SYSTEMS

Maintenance and inspection

PLEASE NOTE! Cut power to the equipment before starting repair or maintenance work!

In order to guarantee fault-free operation and a long service life, the following maintenance procedures must be carried out:

Procedure	Interval
Lubrication of feed auger bearings during first use	Twice a year
Operational testing of flame control thermostat Raise the setting value of the thermostat until an alarm is set off	Twice a year
Operational testing of burn back thermostat Lower the setting value of the thermostat until an alarm is set off	Twice a year
Operational testing of AVTA valve Immerse the sensor in hot water (°C over the setting value) until the valve opens Recommendation: disconnect the water pipe from the burner auger and intermediate tank and direct the water down a floor drain, for example.	Twice a year
Operational testing of pulse-controlled burn back protector. Adjust the settings value to a lower temperature until the magnetic valve opens. Recommendation: disconnect the water pipe from the burner auger and direct the water down a floor drain, for example.	Once a year
Check that the powder extinguisher system bottle is pressurised.	Weekly
Check that the use-by date on the bottle has not expired.	Weekly
In principle, the fan motors do not require servicing. The auger motor gearboxes are lubricated for life.	
Other devices installed in the equipment in accordance with the relevant instructions	

Burner cleaning	Interval
Inspection of condition of grate surfaces and ceramics. Open the airholes from grate blocks and remove the ash from grate surfaces. Check the condition of side ceramics. If ceramics have worn out, they must be changed.	Twice a month or, if necessary
<p>Checking and cleaning the bottom of the grate.</p> <p>This operation must be carried out, otherwise petrified ash will prevent moving grates from functioning and the grate actuating mechanism will break. The warranty does not cover damage resulting from faulty servicing.</p> <p>Twice a month or more often if necessary:</p> <ul style="list-style-type: none"> • Open the end service hatches (8) and remove one of them along with its fans. • Remove the ash accumulated under the moving grates with a vacuum cleaner or a rake. • Make sure that all rammers can move freely and close the hatches. 	
Operational inspection of the hydraulics and fans	Once a month

■ TROUBLE-SHOOTING

■ Instructions when malfunctions may arise

Malfunction	Cause	Action
The safety apparatus has stopped the equipment.	The motor guard has tripped owing to excessive resistance.	Remove the obstacle preventing movement of the auger by turning the auger backwards and check that the auger turns freely. Reset the alarm.
	The motor guard has tripped due to lack of phase.	Check the power supply. Reset the alarm.
	The boiler or burner head overheat protection has tripped as a result of boiler overheat.	Find out the reason for the overheat. Remove the causes of the malfunction. Reset the overheat protection. Reset the alarm.
	The flame control thermostat has tripped because the flue gas temperature has fallen below the settings value.	Check fuel feed: Restart the unit. If necessary, reduce the flame control thermostat settings value.
	The burn back thermostat has tripped because the surface temperature of the auger pipe has risen above the settings value.	Find out the causes of the burn back. Start up the unit if it is safe to do so. If necessary, change the adjustment values (e.g. the temperature of the unit may cause a false alarm).
	The AVTA valve has tripped due to auger pipe overheat, and has filled the intermediate tank with water.	Drain the water out through the drain hole in the bottom of the water tank. Send the wet fuel through the burner head to the ashbox. Feed dry fuel into the burner head and start the unit.
	The displacement limit has tripped because the boiler or burner auger has been displaced.	Remove excess fuel from the boiler and burner. Check the pipe- and other connections of the unit as well as the operation of the flame control.
	The limit switches of the hatches have tripped because one of the hatches was open.	Find out the reason for the tripping. Shorten the discharger operating time. Check the operation of the intermediate tank photocell.
	The flue gas extractor has stopped.	Find out the cause of the malfunction, in the power supply or the frequency converter.

■ TROUBLE-SHOOTING

Malfunction	Cause	Action
The AVTA valve is leaking water.	Impurities in the valve.	Remove and clean.
The pulse-controlled burn back protector valve is leaking water.	Impurities in the valve or the flow direction of the valve is wrong.	Remove and clean, check flow direction.
The pulse-controlled burn back protector valve does not open.	Network pressure too high.	Reduce pressure to 3 bar.
Insufficient heat.	Storage auger feed insufficient, smoke entering the intermediate tank and disturbing the photocell.	Ensure sufficient underpressure in the boiler.
	Dust from the fuel disturbing the photocell in the intermediate tank.	Hopper filling time must be shortened to 8-12 secs.
The unit has stopped. Alarm.		Check what is causing the alarm. Find out the reason for the alarm..

■ INSTRUCTIONS IN CASE OF EMERGENCY

The Ariterm bio-burner is a safe piece of equipment, if it is used correctly and serviced according to the instructions.

Some possible emergencies are described here together with instructions for dealing with them.

■ **Burn back** (fire has spread from the burner to the burner auger)

The burn back protectors react to a rise in temperature of the burner auger as follows:

1. The pulse-controlled burn back protector sprays water onto the fuel, increasing its moisture content and the fire is doused before it has time to spread further. The unit does not stop and does not emit an alarm. Protection can be extended with a non-return valve, pressure tank and pressure warning gauge. **FOR MORE INFORMATION SEE THE AUTOMATION SYSTEM OPERATING INSTRUCTIONS!**
2. The burn back thermostat emits an alarm for the burn back, the burner auger and hopper are forced to empty. The combustion air fans are stopped and flue gas extractor continues to function. The objective of the safety measures is to force the fire pocket back to the burner and bring the equipment to a halt. The storage auger does not move and does not transport new fuel to the burner auger.
3. The AVTA valve trips and fills the auger pipe and hopper with water. Protection can be extended with a non-return valve, pressure tank and pressure warning gauge. Only for wood chip systems!

If the fire has spread to the fuel storage, **DO NOT** open the storage door or hatch. **CALL THE FIRE BRIGADE!** Open the storage sprinkler system valve slowly (if fitted).

■ TECHNICAL SPECIFICATIONS

	500 kW	700 kW	1000 kW	1500 kW
Power supply	Through the control centre. The parameters of the main fuse must be checked on a case-by-case basis			
Power supply cable	See wiring diagram !			
Hydraulic cylinders	2 x PN Q40/25x150 LAP700-HS	2 x PN Q40/25x150 LAP700-HS	2 x PN Q40/25x240 PN LAP1000-HS	3 x PN Q40/25x240 PN LAP1000-HS
Limit switch	Omron E2A-M12KS04-WP-B1			
Combustion air fan	2+2 x CMP-512-2T (13370)	2+2 x CMP-514-2T (13346)	2+3 x CMP-616-2T (13372)	3+3 x CMP-616-2T (13372)
Augers for pellet use angle 15°	Ø114 mm	Ø114 mm, 2 pcs	Ø114 mm, 2 pcs	Ø114 mm, 2 pcs
Augers for other fuels angle 15°	Ø194 mm	Ø159 mm, 2 pcs	Ø194 mm, 2 pcs	Ø194 mm, 2 pcs

Burner auger motors used in the systems

Burner auger 114 mm	0.55 kW
Burner auger 159 and 194 mm	1.1 kW / 1.5 kW

■ HYDRAULIC SYSTEM

■ COMMISSIONING AND MAINTENANCE INSTRUCTIONS OF HYDRAULIC SYSTEMS

Contents:

1. General Instructions
2. Installation
3. Tank Inspection and Filling
4. Starting and Commissioning
5. Maintenance
6. Oil Recommendations

■ GENERAL INSTRUCTIONS

The hydraulic system consists of selected components that must be installed, maintained and calibrated according to operating conditions. It is essential, not only to select the right components for the hydraulic system, but also to install, commission and maintain them in accordance with the given instructions. The maintenance and operating instructions must be read and followed carefully to ensure that the supplied equipment work normally. These instructions are intended primarily for equipment that is operated under normal site/industrial conditions. If, for example, the operating temperature varies significantly or the environmental conditions are exceptionally humid or dusty, please contact the manufacturer. We are happy to provide you with further information.

■ INSTALLATION Power Units

The installation site should be dry and the environmental temperature should be as constant as possible. You should additionally leave sufficient space between the tank, electric motor and walls for adequate air circulation around the tank. Air circulation plays an important role in the cooling process. The equipment has to be fastened on a level surface using all of the equipment's anchor points. In unclean environments and especially in outdoor use we recommend the use of protective roof or casing. When using a protective casing, it is important to take free air circulation into consideration to prevent overheating. The protective casing should be designed to enable easy maintenance of the equipment and to ensure visibility of the pressure gauges and oil level indicators.

HYDRAULIC DIAGRAM

Multijet 500-1000 kW

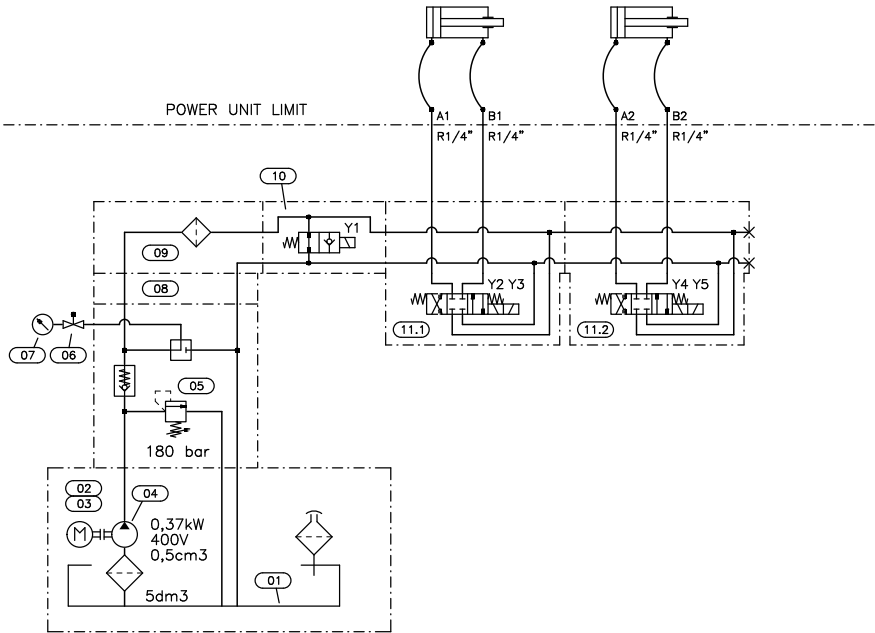

POS	QTY	COMPONENT DESCRIPTION	TYPE	MANUFACTURER
01	1	RESERVOIR	SL65H	TECFLUID
02	1	ELECTRIC MOTOR	MS71B-4 B34 (0,37kW 400V 1370r/min)	MOVES
03	1	COUPLING	FAM71	TECFLUID
04	1	GEAR PUMP	P004 (0,50cm ³)	TECFLUID
05	1	CENTRAL MANIFOLD	M1A/180	TECFLUID
06	1	SHUT-OFF VALVE	FPE1/4 1GB	
07	1	PRESSURE GAUGE	ø63 0-250bar	
08	1	MODULAR BLOCK	B09	TECFLUID
09	1	PRESSURE FILTER	B39_40	TECFLUID
10	1	2/2 CARTRIDGE VALVE	V05_38	TECFLUID
	1	SOLENOID 24VDC 18W	C1500010B	TECFLUID
11.1-2	2	4/3 CARTRIDGE VALVE	V61	TECFLUID
	4	SOLENOID 24VDC 22W	C1500120B	TECFLUID

HYDRAULIC DIAGRAM

Multijet 1500 kW

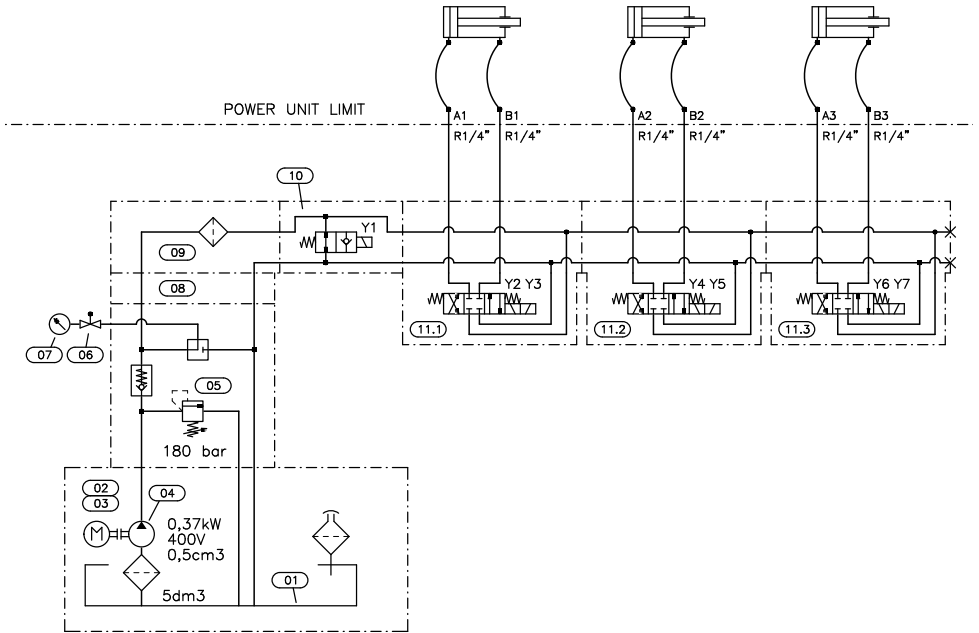

POS	QTY	COMPONENT DESCRIPTION	TYPE	MANUFACTURER
01	1	RESERVOIR	SL65H	TECFLUID
02	1	ELECTRIC MOTOR	MS71B-4 B34 (0,37kW 400V 1370r/min)	MOVES
03	1	COUPLING	FAM71	TECFLUID
04	1	GEAR PUMP	P004 (0,50cm ³)	TECFLUID
05	1	CENTRAL MANIFOLD	M1A/180	TECFLUID
06	1	SHUT-OFF VALVE	FPE1/4 1GB	TECFLUID
07	1	PRESSURE GAUGE	ø63 0-250bar	
08	1	MODULAR BLOCK	B09	TECFLUID
09	1	PRESSURE FILTER	B39_40	TECFLUID
10	1	2/2 CARTRIDGE VALVE	V05_38	TECFLUID
11.1-3	1	SOLENOID 24VDC 18W	C1500010B	TECFLUID
	3	4/3 CARTRIDGE VALVE	V61	TECFLUID
	6	SOLENOID 24VDC 22W	C1500120B	TECFLUID

500 - 1500 kW DIMENSIONS

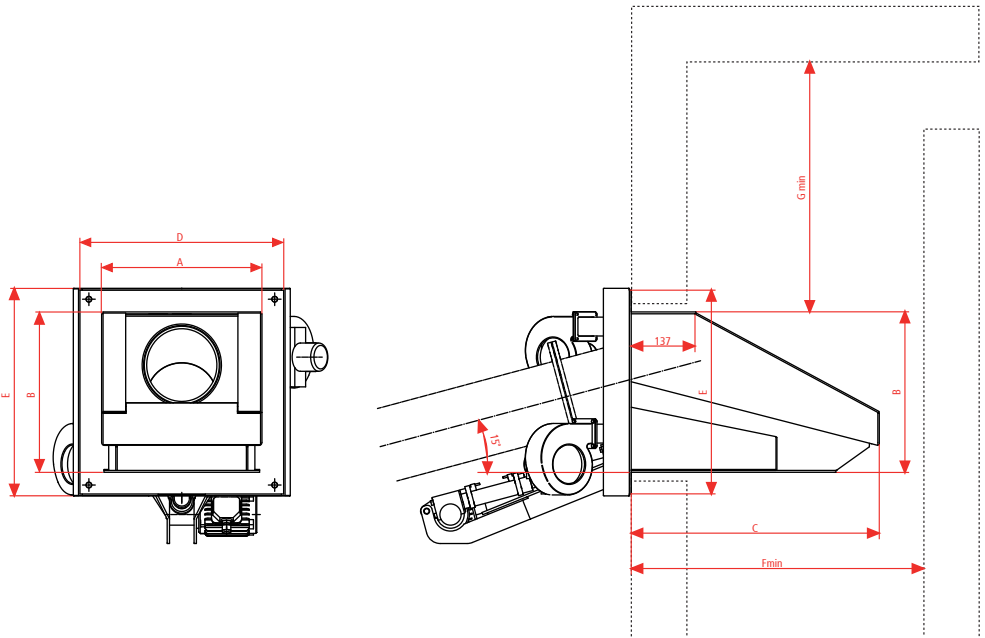

Main measurements of the Multijet burner

Burner kW	A	B	C	D	E	F min	G min	Weight kg
500	850	685	1216	942	777	1240	1200	800
700	920	768	1402	1012	860	1430	1400	1130
1000	1106	924	1727	1266	1085	1750	1700	1430
1500	1406	1094	2022	1566	1255	2060	2000	1720

MULTIJET 500 kW

Burner kW	Blocks in a row	Block rows	Blocks total	Long shafts	Short shafts
500	10	9	90	4	10

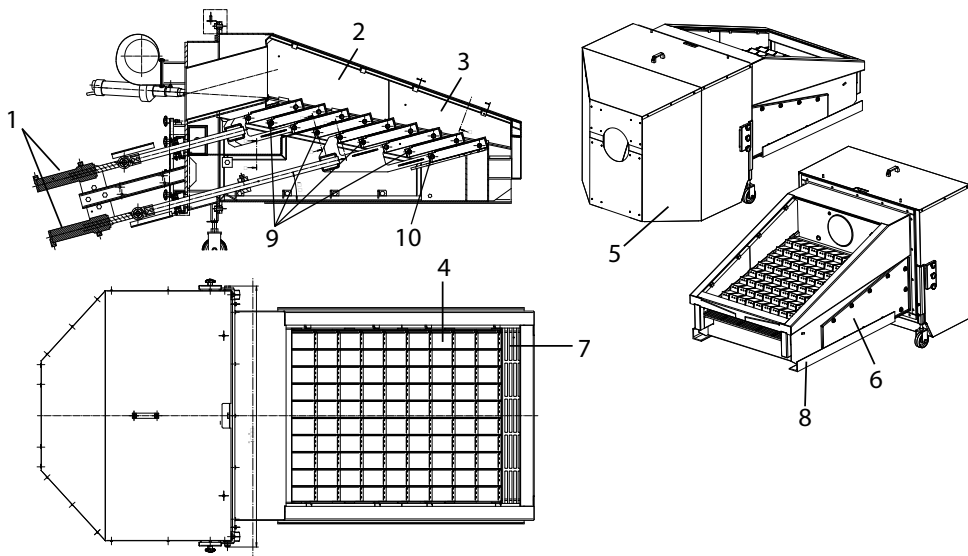

Parts in burner			
No	Part	pcs	Art no
1	Cylinder d40/25x150	2	13952
2	Side ceramic, upper (right/left)	2	13896 / 14539
3	Side ceramic, lower (right/left)	2	13897 / 14540
4	Grate block	90	13911
5	Protective housing	1	
6	Lower side box	2	
7	Ash grate (ACCESSORY)	1	LAP-500006
8	Angle iron	2	
9	Grate shaft, long	4	13893
10	Grate shaft, short	14	13892

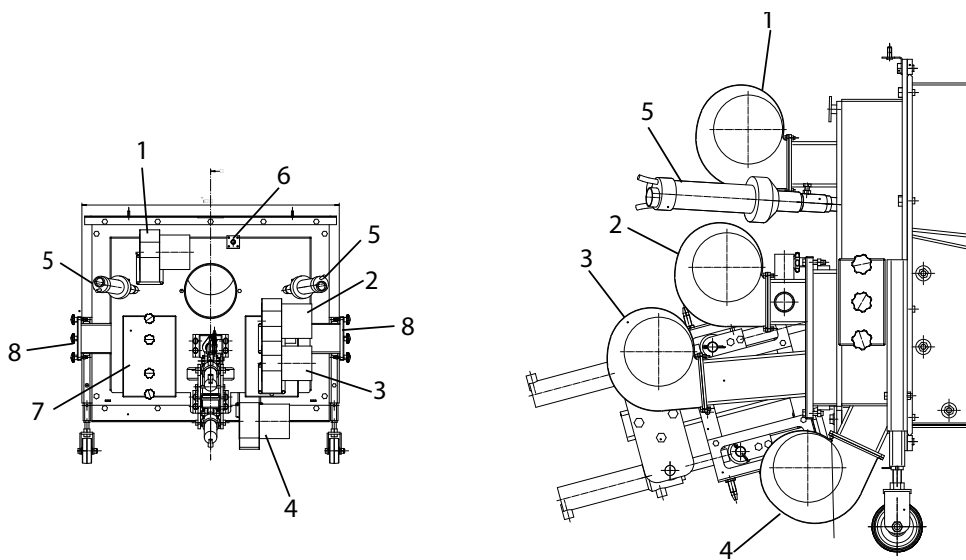

Parts in burner

No	Part	pcs	Art no
1	Secondary fan 1, Sodeca CMP-512-2T, 3~, 0.08 kW	1	13370
2	Primary fan 1, Sodeca CMP-512-2T, 3~, 0.08 kW	1	13370
3	Primary fan 2, Sodeca CMP-512-2T, 3~, 0.08 kW	1	13370
4	Secondary fan 2, Sodeca CMP-512-2T, 3~, 0.08 kW	1	13370
5	Ignition fan, Leister Triac S (ACCESSORY)	1-2	13734
6	Flame sensor pipe (ACCESSORY)	1	
7	Cleaning hatch	1	
8	Side hatch	2	
	Inductive sensor Omron E2A-M12KS04-WP-B1	8	13962
	Joint bearing GE 30ES FK 001	2	13467

MULTIJET 700 kW

Burner kW	Blocks in a row	Block rows	Blocks total	Long shafts	Short shafts	Front shafts
700	11	11	121	5	6	14

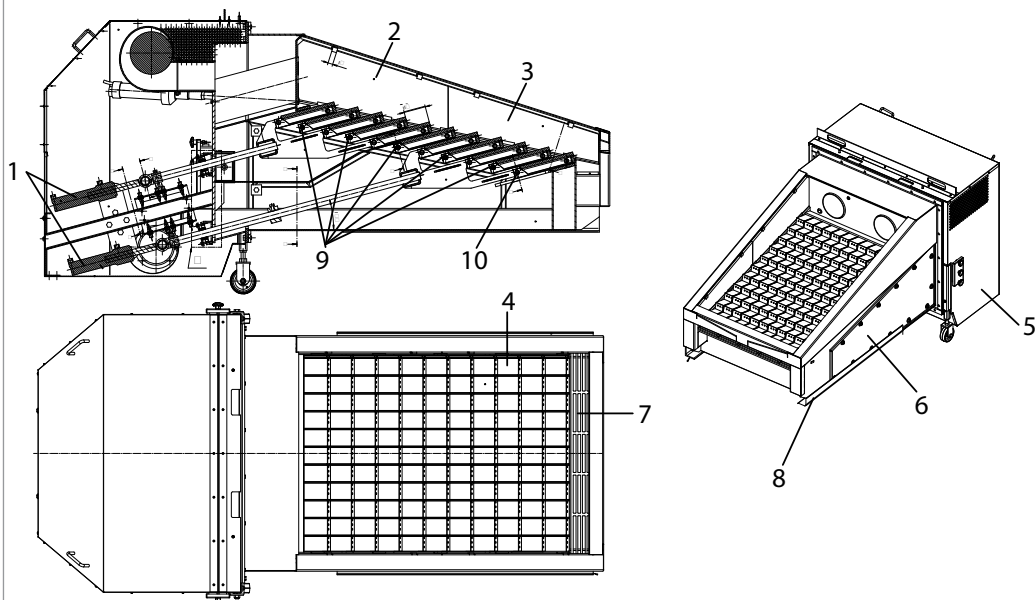

Parts in burner			
No	Part	pcs	Art no
1	Cylinder d40/25x150	2	13952
2	Side ceramic, upper (right/left)	2	13945 / 14542
3	Side ceramic, lower (right/left)	2	13946 / 14543
4	Grate block	121	13911
5	Protective housing	1	
6	Lower side box	2	
7	Ash grate (ACCESSORY)	1	LAP-700006
8	Angle iron	2	
9	Grate shaft, long	5	13941
10	Grate shaft, short	6	13944

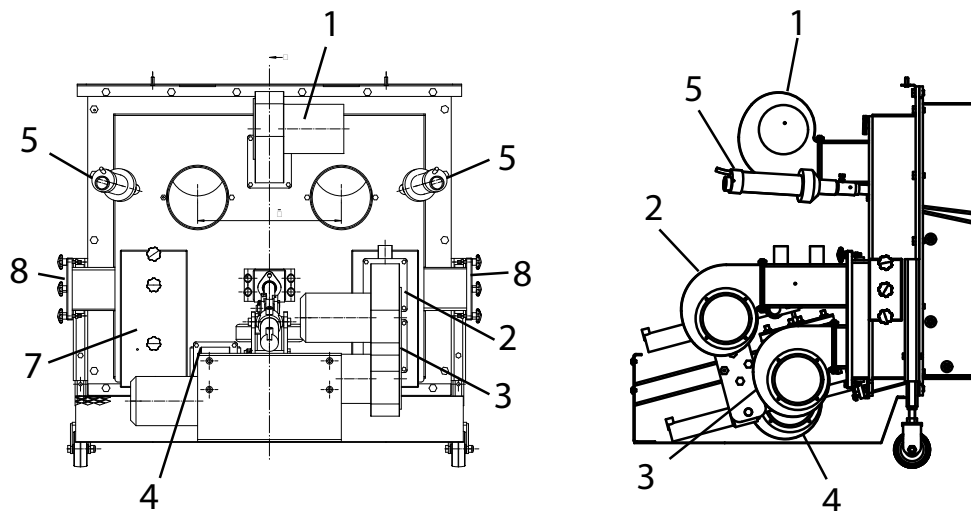

Parts in burner

No	Part	pcs	Art no
1	Secondary fan 1, Sodeca CMP-514-2T, 3~, 0.18 kW	1	13346
2	Primary fan 1, Sodeca CMP-514-2T, 3~, 0.18 kW	1	13346
3	Primary fan 2, Sodeca CMP-514-2T, 3~, 0.18 kW	1	13346
4	Secondary fan 2, Sodeca CMP-514-2T, 3~, 0.18 kW	1	13346
5	Ignition fan, Leister Triac S (ACCESSORY)	1-2	13734
6	Flame sensor pipe (ACCESSORY)	1	
7	Cleaning hatch	1	
8	Side hatch	2	
	Inductive sensor Omron E2A-M12KS04-WP-B1	8	13962
	Joint bearing GE 30ES FK 001	2	13467

MULTIJET 1000 kW

Burner kW	Blocks in a row	Block rows	Blocks total	Long shafts	Middle shafts
1000	9	9	81	4	14

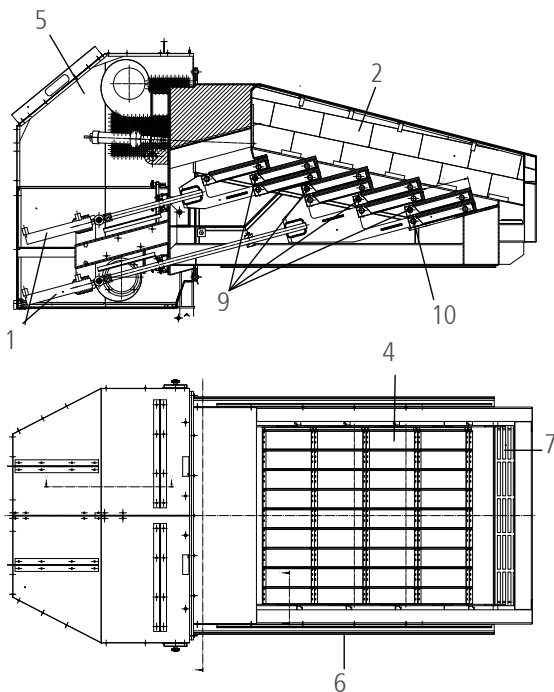

Parts in burner				
No	Part	pcs	Art no	
1	Cylinder d40/25x240	2	13961	
2	Side ceramic	2		
4	Grate block	81	13943	
5	Protective housing	1		
6	Lower side box	2		
7	Ash grate (ACCESSORY)	1	LAP-1000133a	
9	Grate shaft, long	4	13958	
10	Grate shaft, short	14	14046	

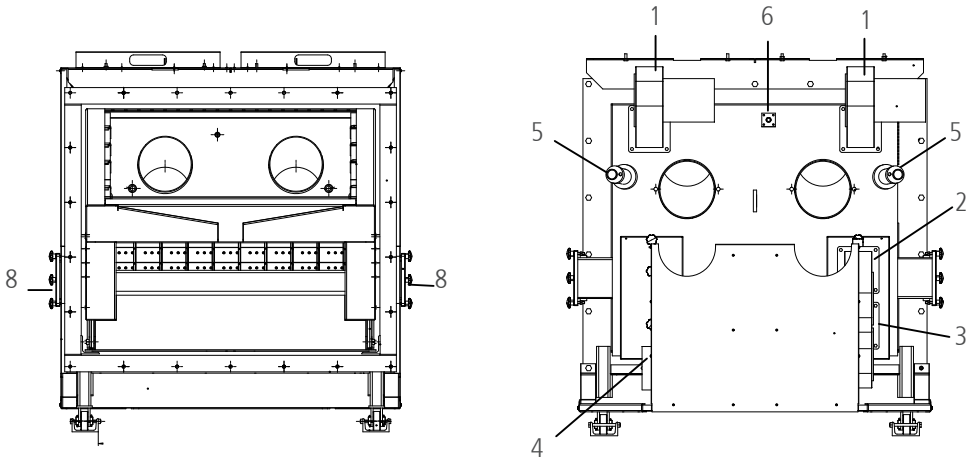

Parts in burner			
No	Part	pcs	Art no
1	Secondary fan 1, Sodeca CMP-616-2T, 3~, 0.37 kW	2	13372
2	Primary fan 1, Sodeca CMP-616-2T, 3~, 0.37 kW	1	13372
3	Primary fan 2, Sodeca CMP-616-2T, 3~, 0.37 kW	1	13372
4	Secondary fan 2, Sodeca CMP-616-2T, 3~, 0.37 kW	1	13372
5	Ignition fan, Leister Triac S (ACCESSORY)	1-2	13734
6	Flame sensor pipe (ACCESSORY)	1	
7	Cleaning hatch	1	
8	Side hatch	2	
	Inductive sensor Omron E2A-M12KS04-WP-B1	8	13962
	Joint bearing GE 30ES FK 001	2	13467

MULTIJET 1500 kW

Burner kW	Blocks in a row	Block rows	Blocks total	Long shafts	Short shafts	Front shafts
1500	12	11	132	5	6	11

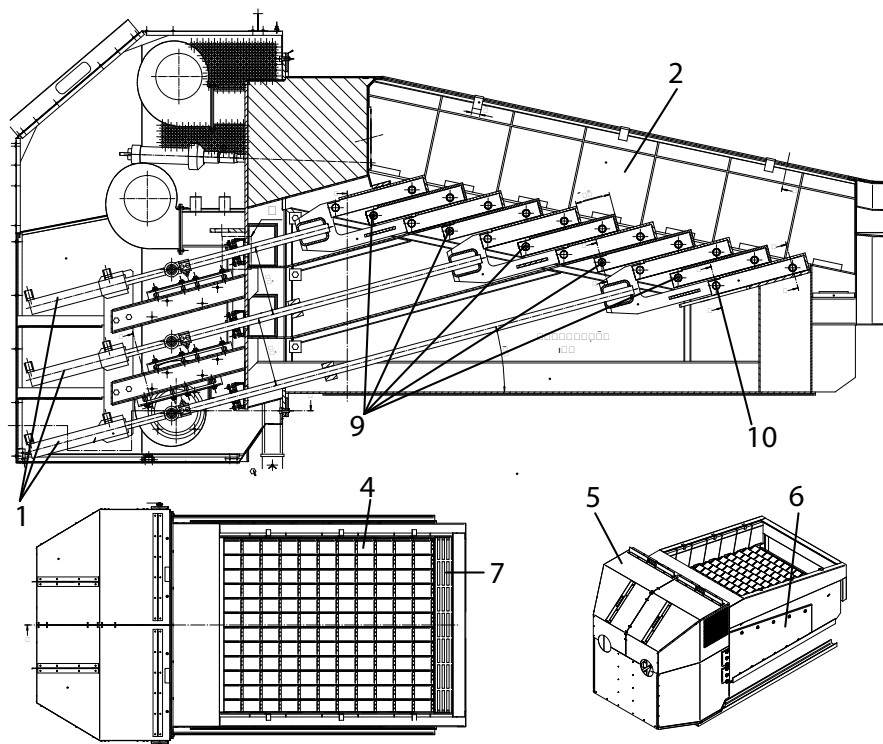

Parts in burner			
No	Part	pcs	Art no
1	Cylinder d40/25x240	3	13961
2	Side ceramic	2	
4	Grate block	132	13943
5	Protective housing	1	
6	Lower side box	2	
7	Ash grate (ACCESSORY)	1	
9	Grate shaft, long	5	
10	Grate shaft, short	6	

MULTIJET 1500 kW

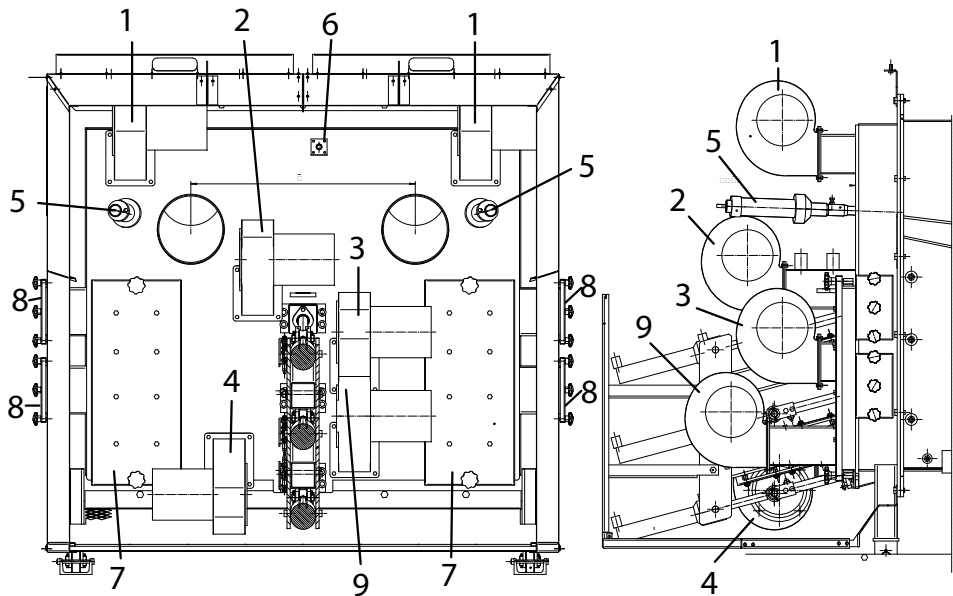

Parts in burner			
No	Part	pcs	Art no
1	Secondary fan 1, Sodeca CMP-616-2T, 3~, 0,37 kW	2	13372
2	Primary fan 1, Sodeca CMP-616-2T, 3~, 0,37 kW	1	13372
3	Primary fan 2, Sodeca CMP-616-2T, 3~, 0,37 kW	1	13372
4	Secondary fan 2, Sodeca CMP-616-2T, 3~, 0,37 kW	1	13372
5	Ignition fan, Leister Triac S (ACCESSORY)	1-2	13734
6	Flame sensor pipe (ACCESSORY)	1	
7	Cleaning hatch	1	
8	Side hatch	2	
9	Primary fan 3, Sodeca CMP-616-2T, 3~, 0,37 kW	1	13372
	Inductive sensor Omron E2A-M12KS04-WP-B1	12	13962
	Joint bearing GE 30ES FK 001	3	13467

PROPERTIES OF BIO-FUELS

Property	Density	Size of piece	Moisture	Power rating	Amount of ash	Temp. softening	Temp. melting	Suitability
Unit	kg / 1-m ³	mm	%	kWh / i-m ³	% (of ka)	C	C	to MJ burner
Wood chip, dry	180 - 300	20 - 50	20 - 25	800 - 1000	0.5 - 2.0	1200 - 1400	1300 - 1600	Suitable
Wood chip, moist	250 - 350	20 - 50	45 - 50	700 - 900	0.5 - 2.0	1200 - 1400	1300 - 1600	Suitable
Bark, mixed	200 - 400	(60 - 200)	40 - 60	400 - 700	1.5 - 3.5	950 - 1050	1400 - 1450	Suitable
Wood pellet	550 - 670	ø 6 - 12	6 - 12	2900 - 3200	0.5 - 1.0	1120 - 1350	1250 - 1550	Suitable
Sawdust	250 - 300	1 - 5	45 - 55	400 - 700	0.4 - 1.0	1120 - 1350	1250 - 1550	Suitable with reservations (must be tested on case-by-case basis)
Cutter chips	80 - 120	-	5 - 15	450 - 550	0.4 - 0.5	1120 - 1350	1250 - 1550	Suitable with reservations (must be tested on case-by-case basis)
REF pellets	300 - 500	ø 6 - 15	2 - 5	2000 - 3000	5.0 - 10.0	1150 - 1250	1200 - 1300	Suitable with reservations (must be tested on case-by-case basis)
Grain (oats)	550 - 650	-	10 - 20	2300 - 3000	2.0 - 4.0	1050 - 1150	1350 - 1500	Suitable
Straw (loose)	70 - 90	-	15 - 25	300 - 400	4.0 - 6.0	750 - 1000	1150 - 1400	Suitable with reservations (must be tested on case-by-case basis)

The quality and properties of fuels vary greatly, even when they go by the same name. In order to determine fuel quality, standards and other quality guidelines exist for different substances. A Pan-European guideline for all bio-fuels is ready and awaiting final approval.

There is also a lot of quality information on fuels available in print and also from fuel suppliers.

■ WARRANTY

The equipment delivered by Ariterm is guaranteed for 1 year. The guarantee is valid for one year from the start-up date or up to 18 months from the date of delivery. The pressure vessels manufactured by Ariterm are guaranteed for 5 years from the date of delivery.

New parts are delivered to replace the faulty ones and the guarantee covers manufacturing and material faults. The guarantee does not cover consumables or travel expenses.

The guarantee does not cover possible faults due to faulty design or installation, improper service or use errors, or damages caused by off-specification fuel.

Guarantee for spare parts is 12 months. Ariterm will supply the replacement parts to replace the damaged ones. Unless required by mandatory law, the agreement does not include any other guarantees. This paragraph determines exhaustively the defect liability of the Vendor and the buyer's legal remedies in a defect situation.

DECLARATION OF CONFORMITY



VAATIMUSTENMUKAISUUSVAKUUTUS

Valmistaja: ARITERM OY
Osoite: PL 59, 43101 SAARIJÄRVI

Laite: **Multijet –biopoltin**

Valmistaja vakuuttaa,

- että valmistuksessa on noudatettu oheisten direktiivien vaatimuksia:

Konedirektiivi	2006/42/EY
Pienjännitedirektiivi	2006/95/EY
EMC-direktiivi	2004/108/EY

DECLARATION OF CONFORMITY - MANUFACTURERS DECLARATION

Manufacturer: ARITERM OY
Address: P.O.BOX 59, FIN-43101 SAARIJÄRVI

Equipment: **Multijet bio burner**

Manufacturer assures,

- that in the production of the burner following directives have been applied:

Machine directive	2006/42/EC
Low voltage directive	2006/95/EC
EMC directive	2004/108/EC

FÖRSÄKRAN OM ÖVERENSSTÄMMELSE - TILLVERKAREDEKLARATION

Tillverkare: ARITERM OY
Adress: P.O.BOX 59, FIN-43101 SAARIJÄRVI

Apparat: **Multijet biobrännare**

Tillverkare försäkrar,

- att vid tillverkningen av brännaren har man iakttagit följande direktiven:

Maskindirektivet	2006/42/EG
Lågspänningsdirektivet	2006/95/EG
EMC direktivet	2004/108/EG

20.1.2011, Ariterm Oy

Petteri Korpioja
Toimitusjohtaja
Managing director
Verkställande direktör



ARITERM

ARITERM OY | PL 59 (Uuraistentie 1), 43101 Saarijärvi | Finland
Tel +358 14 426 300, fax +358 14 422 203 | www.ariterm.fi

ORGANISATION
CERTIFIED BY
Inspecta

ISO 9001
ISO 14001