

BIC 1B0-ITA50-M30MF1-SM4A5A  
BIC 2B0-ITA50-M30MF1-SM4A5A  
User's Guide



## Table of Contents

<b>1</b>	<b>Safety</b>	<b>2</b>
1.1.	<b>Installation and Startup</b>	<b>2</b>
1.2.	<b>General Safety Notes</b>	<b>2</b>
	Dangerous Voltage	2
	Approved Use	2
1.3.	<b>Safety Precautions</b>	<b>2</b>
	Protection from electromagnetic fields	3
1.4.	<b>Resistance to Aggressive Substances</b>	<b>3</b>
<b>2</b>	<b>System Overview</b>	<b>4</b>
2.1.	<b>System Overview</b>	<b>4</b>
<b>3</b>	<b>Installation</b>	<b>5</b>
3.1.	<b>Mutual Interference</b>	<b>5</b>
3.2.	<b>Installation in metal</b>	<b>5</b>
<b>4</b>	<b>Energy Transmission</b>	<b>6</b>
4.1.	<b>Derating</b>	<b>6</b>
	Derating curve	6
	Note	6
	Permitted Angle Offset	7
	Ambient temperature	7
4.2.	<b>Power reduction</b>	<b>7</b>
<b>5</b>	<b>IO-Link communication</b>	<b>8</b>
5.1.	<b>Transmission properties</b>	<b>8</b>
	IO-Link communication	8
	PIN2	8
5.2.	<b>Connection Time</b>	<b>8</b>
<b>6</b>	<b>Technical Data</b>	<b>9</b>
6.1.	<b>Base</b>	<b>9</b>
	LED 1 / LED 2	9
	Mechanical Data	9
	Electrical Data	10
	Operating conditions	10
	Pin assignment	10
6.2.	<b>Remote</b>	<b>11</b>
	LED 1 / LED 2	11
	Mechanical Data	11
	Electrical Data	11
	Operating conditions	11
	Pin assignment	11
<b>7</b>	<b>Ordering information</b>	<b>12</b>

**1 Safety**

**1.1. Installation and Startup**



**Attention!**

Installation and startup are to be performed by trained technical personnel only. Skilled specialists are people who are familiar with the work such as installation and the operation of the product and have the necessary qualifications for these tasks. Any damage resulting from unauthorized tampering or improper use shall void warranty and liability claims against the manufacturer. The operator is responsible for ensuring that the valid safety and accident prevention regulations are observed in specific individual cases.

**1.2. General Safety Notes**

**Commissioning and inspection**

The operating company shall be responsible for observance of locally applicable safety regulations.

Before commissioning, carefully read the User's Guide.

The system must not be used in applications in which the safety of persons depends on the function of the device.

**Intended use**

Warranty and liability claims against the manufacturer shall be rendered void by damage from:

- Unauthorized tampering
- Improper use
- Use, installation or handling contrary to the instructions provided in this User's Guide.

**Obligations of the Operating Company**

The device is a piece of equipment in accordance with EMC Class A. Such equipment may generate RF noise. The owner/operator must take appropriate precautionary measures against this for its use. The device may be used only with a power supply approved for this. Only approved cables may be connected.

**Malfunctions**

In the event of defects and device malfunctions that cannot be rectified, the device must be taken out of operation and protected against unauthorized use.

**Dangerous Voltage**



**Attention!**

Before working on the device, switch off its power supply.

**Approved Use**



**Attention!**

Inductive coupling systems (BIC) are devices for contact-free energy and signal transmission in industrial environments.

Use is particularly not allowed:

- In environments with explosive atmospheres
- In application in which the safety of people or machines can be affected by transmitted signals (safety-relevant circuits).

**1.3. Safety Precautions**



**Caution!**

Risk of burning on hot surfaces! The sensing surface heats up even under normal operating conditions. Keep hands and objects away from the sensing surface. Metallic objects must not get distances A, B or between the sensing surfaces of the base and remote. Fire hazard! (cf. Section 3.2)

**Protection from electromagnetic fields**



**Protection from electromagnetic fields during operation and assembly**

At a distance of 300 mm the magnetic field strength of a BIC is less than 0.092  $\mu\text{T}$ . Based on the EU Council recommendation 1999/5/EC, in accordance with EN 62311:2008, this distance is regarded as the basic limit value or reference value for the safety of persons in electromagnetic fields. For persons with live medical implants, additional (operational) limit values may apply.

**1.4. Resistance to Aggressive Substances**



**Attention!**

The BNI modules always have good chemical and oil resistance. When used in aggressive media (such as chemicals, oils, lubricants and coolants, each in a high concentration (i.e. too little water content)), the material must first be checked for resistance in the particular application. No defect claims may be asserted in the event of a failure or damage to the BIC modules caused by such aggressive media.



**Note**

In the interest of continuous improvement of the product, Balluff GmbH reserves the right to change the technical data of the product and the content of these instructions at any time without notice.

**Balluff Inductive Coupler System**  
**BIC 1B0-ITA50-M30MF1-SM4A5A (Base)**  
**BIC 2B0-ITA50-M30MF1-SM4A5A (Remote)**

**2 System Overview**

**2.1. System Overview**

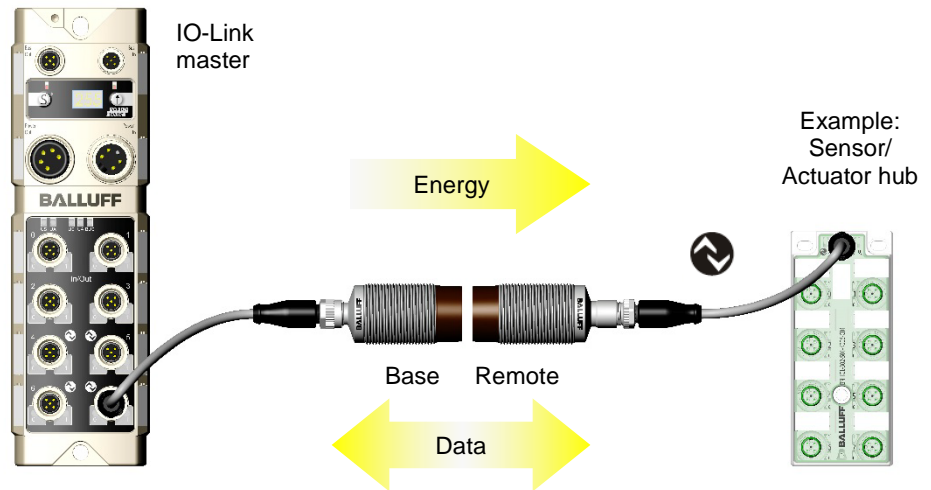

**System description:**

The BIC system consists of two components, the Base and the Remote. It transmits electrical power from the stationary component (Base) over the air gap to the mobile component (Remote). The transmission distance of the Base and Remote may be up to 10mm depending on the power consumed.

In SIO mode the BIC system sends the IO signal of the device to the BIC system Base.

In IO-Link mode the BIC system transmits the IO-Link port data from the IO-Link master (see previous figure) to the BIC system Remote. In this way, the IO-Link functionality of the IO-Link master port is made available without contact on the remote.

Operation of the BIC system is possible using Balluff IO-Link masters. Use of masters from other manufacturers has been successfully tested, but this is not guaranteed.



**Note**

Please pay special attention to the inrush peak currents of the devices connected to the remote during system planning. The transient behavior (inrush peak current value and duration) of the remote unit depends on the distance of the base unit, the distance of metallic objects and the temperature.

When using a Profibus IO-Link master module from Balluff GmbH only modules having the following hardware version are compatible.

PBS Master	Hardware version
BNI PBS-502-101-Z001	HW07
BNI PBS-504-002-K008	HW03
BNI PBS-507-002-Z011	HW06

### 3 Installation

#### 3.1. Mutual Interference

To prevent mutual interference of data transmission with adjacent bases or remotes, the specified minimum distances must be adhered to:

Typ	A (mm)
BIC 1B0-ITA50-M30MF1-SM4A5A	$\geq 70$
BIC 2B0-ITA50-M30MF1-SM4A5A	$\geq 70$

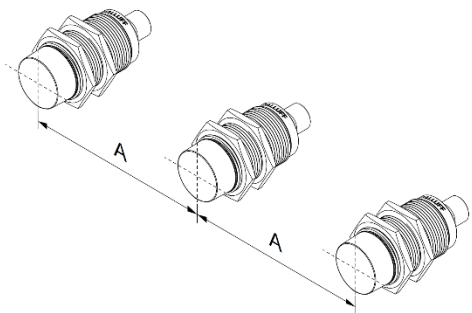

#### 3.2. Installation in metal



**Attention!**

Metallic surroundings may generate induction effects that can damage the device!



**Attention!**

Metallic objects in front of and on the coil cap cause the sensing surface to be heated. The sensing surface is marked by the crosshairs on the housing (see figure in Section 3.1).



**Note**

Install the components so that no metallic objects are in the zone produced by distances A and B. Distances A and B must be maintained independently of each other!

Type	A (mm)	B (mm)
BIC 1B0-ITA50-M30MF1-SM4A5A	$\geq 20$	$\geq 15$
BIC 2B0-ITA50-M30MF1-SM4A5A	$\geq 20$	$\geq 15$

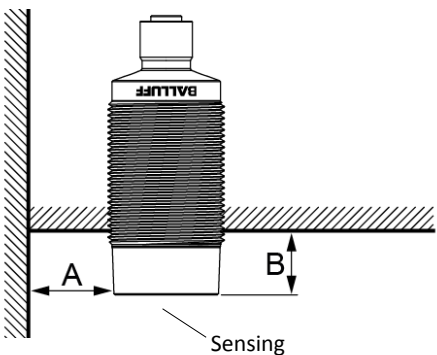

**A:** Lateral separation

**B:** Separation of the sensing surface from the rear mounting surface.

**Balluff Inductive Coupler System**  
**BIC 1B0-ITA50-M30MF1-SM4A5A (Base)**  
**BIC 2B0-ITA50-M30MF1-SM4A5A (Remote)**

**4 Energy Transmission**

The maximum transmittable power with the BIC system depends on the separation, lateral axial offset and angular offset.

**4.1. Derating**

Explanations for increasing the maximum transmittable power as well as increasing the maximum transmission distance.

Reducing the ambient temperature as well as the separation, lateral axial offset and angular offset can increase the maximum transmittable power. Similarly, if the power requirements are low, the transmission distance of the BIC system, for example, can be increased.



**Note**

If the BIC system is operated with a correspondingly large overload, the output voltage of the Remote will collapse.

**Derating curve**

The following illustration shows the typical transmittable power with respect to the transmission distance A without any offset of the BIC system.

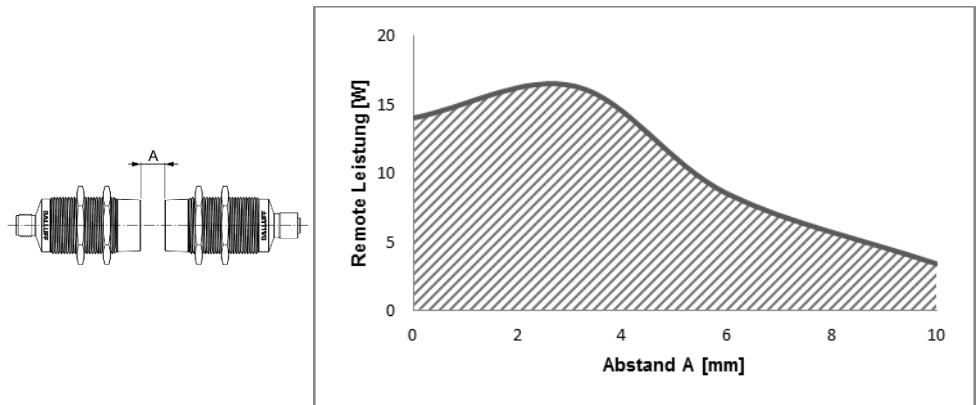

The following illustration shows the typical transmittable power at separation A = 3mm with respect to lateral offset B of the BIC system.

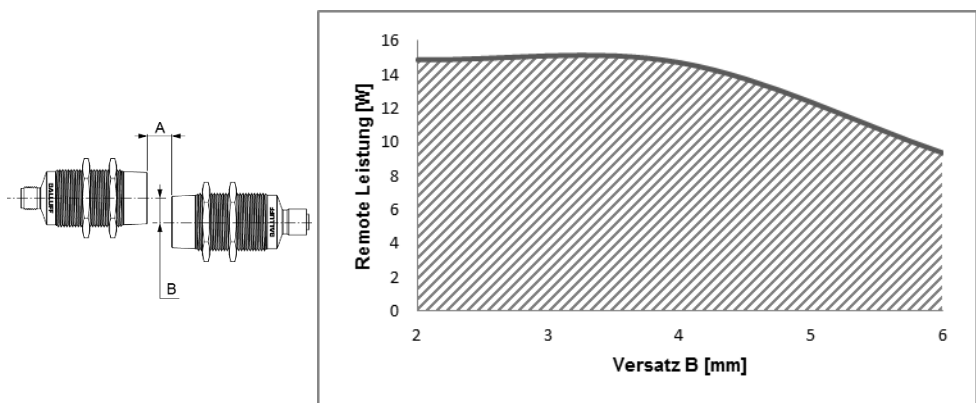

**Note**

The measurements used for the derating curves were performed without any angular offset. The value ranges of the derating curves are to be interpreted as typical values.

## 4 Energy transmission

### Permitted Angle Offset

The following illustration shows the typical angular offset with a load of 500mA of the BIC system.

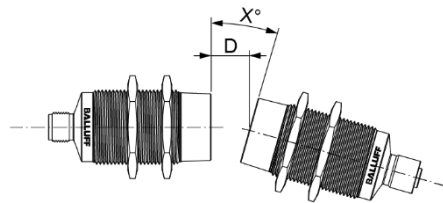

Distance D (mm)	Angle X (°)
1	11
2	8
3	5
4	0

### Ambient temperature

The continuous transmittable power of the system is reduced as a function of the ambient temperature. To protect from damage caused by overheating the power and data transmission are turned off when overtemperature occurs. (cf. Sec. 6.1).

The following illustration shows a typical derating curve of the BIC system at a distance of 3 mm and without lateral offset between the Base and Remote. The BAM01U0 holder was used for attaching the BIC system.

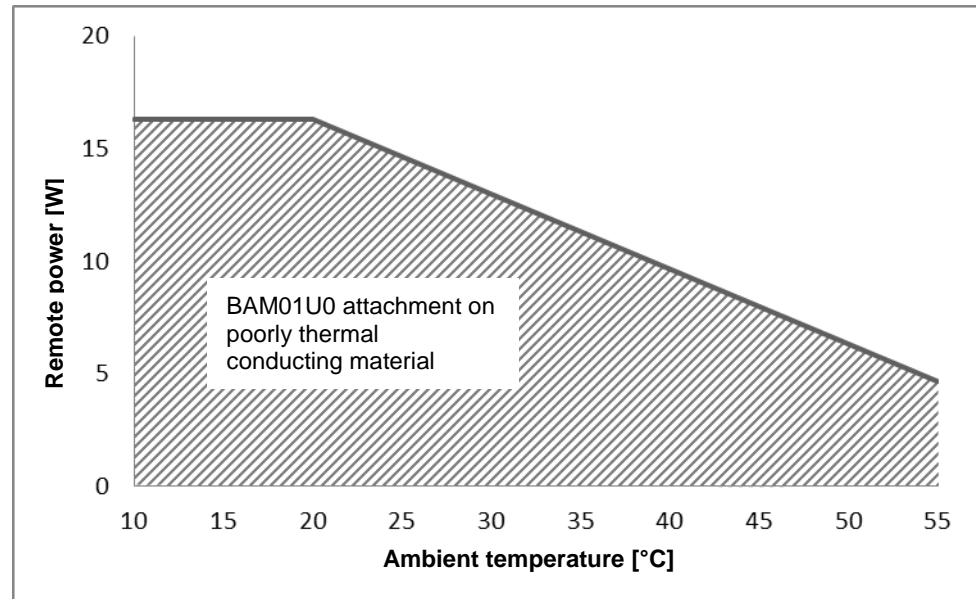

#### Note

If an average greater output current at higher ambient temperature is required than shown above, the continuous output power of the Remote can be increased by means of thermal transfer (e.g. using a heat sink or by attaching to a material which is heat conducting).

### 4.2. Power reduction

To protect people and the environment, the base component automatically reduces power, which is emitted in the form of electromagnetic fields, as soon as the remote component is disconnected.

The technical benefit is the prevention of heating metallic objects that end up in front of the base when the remote is disconnected.



**Balluff Inductive Coupler System**  
**BIC 1B0-ITA50-M30MF1-SM4A5A (Base)**  
**BIC 2B0-ITA50-M30MF1-SM4A5A (Remote)**

**5 IO-Link communication**

**5.1. Transmission properties**

<b>BIC 1B0-ITA50-M30MF1-SM4A5A, BIC 2B0-ITA50-M30MF1-SM4A5A</b>	
Transmission rate	COM2 (38.4 kBaud)
Min cycle time	Device + 2 ms
Process data cycle	Device + 2 ms
SIO mode	yes
Type of master port	A
Process data in	0...32 bytes
Process data out	0...32 bytes

**IO-Link communication**

The BIC system transmits the IO-Link protocol (all IO-Link input and output data as well as diagnostic data), regardless of the length of the process data. The IO-Link protocol is transmitted without any restrictions so the BIC system parameters do not need adjusting. Only the IO-Link device connected to the BIC system has to be integrated in the control.

**This means there is no IODD for the bi-directional BIC M30.**



**Note**

The BIC system can only be operated using Balluff IO-Link masters. Use of masters from other manufacturers has been successfully tested, but this is not guaranteed.

**PIN2**

Pin 2 on the Base transmits the signal status "High Active" from the IO-Link port on the master to the IO-Link device.

**5.2. Connection Time**

The time needed to establish the connection of base and remote is affected by many different variables. Start-up speed and angle play just as much of a role as the IO-Link device connected to the Remote and the IO-Link parameters set within it. The type of IO-Link master used and its parameter settings also affect the connection time. These variables are all application-specific and therefore cannot be generalized.

The measurements carried out by Balluff to determine the connection time were done using a Balluff EtherNet-IP master in combination with the Balluff IO-Link device "BNI IOL-302-00-Z012". The distance from base to remote was 4 mm without axis and angular offset. A total of 100,000 connection cycles comprising a variety of directions and speeds were evaluated.

<b>typical connection time</b>
≤ 500 ms

## 6 Technical Data

### 6.1. Base

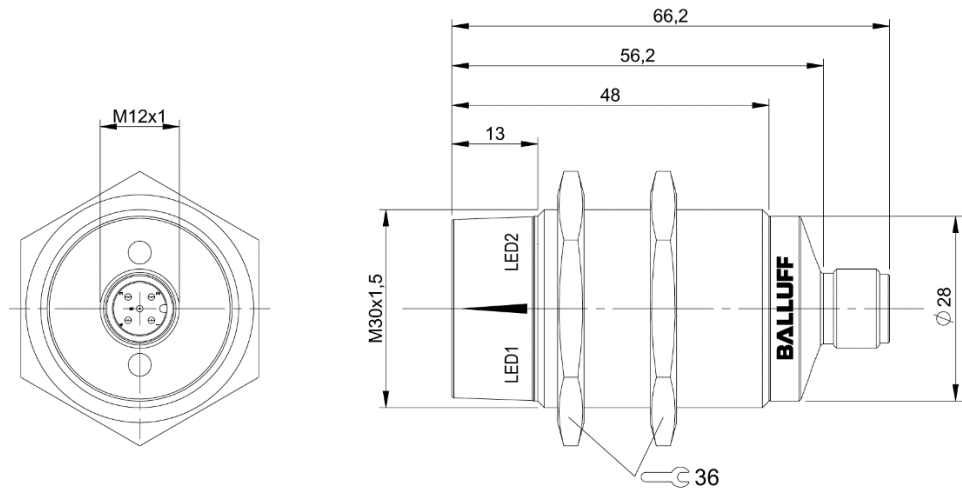

#### LED 1 / LED 2

LED	Indicator	Function
LED 1	Green, static	Supply voltage OK
	Green, inverted flashing	IO-Link communication OK
LED 2	Yellow on	Pin 2 high
	Yellow off	Pin 2 low
	Red, flashing	Undervoltage or overvoltage
	Red, illuminated and stays on	Excess temperature

#### Mechanical Data

Sensing surface material	PC
Housing material	CuZn coated
Housing degree of protection	IP 67 (only in plugged-in and screwed-down state)
Type	M30 x 66,3
Weight	95 g

## 6 Technical Data

<b>Electrical Data</b>	Operating voltage	24 V DC $\pm 10\%$ , corresponding to EN 61131-2
	Current consumption	< 1.4 A
	No-load current	$\leq 200$ mA
	Overload protection	yes
	Ripple	< 1%

<b>Operating conditions</b>	Operating temperature Ta Storage temperature	-5°C ... 55°C (cf. Sec. 4.1) -25°C ... 70°C
	EMC	This product meets the EMC requirements according to the separately provided Declaration of Conformity.
	Vibration/shock	EN 60068-2-6, EN 60068-2-27

### Pin assignment

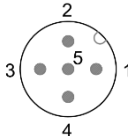
Power (M12, 5-pin connector)		
	Pin	Signal
	1	+24 V
	2	PIN 2 Input
	3	GND, 0
	4	C/Q, IO-Link
	5	nc

6.2. Remote

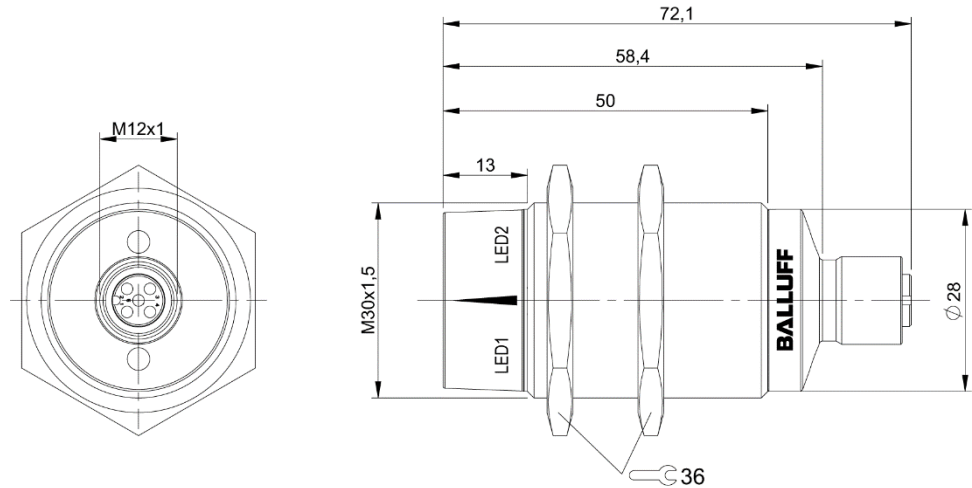

LED 1 / LED 2

LED	Indicator	Function
LED 1	Green, static	Supply voltage OK
	Green, inverted flashing	IO-Link communication OK
LED 2	Yellow on	Pin 2 high
	Yellow off	Pin 2 low

Mechanical Data

Sensing surface material	PC
Housing material	CuZn coated
Housing degree of protection	IP 67 (only in plugged-in and screwed-down state)
Dimensions (W x H x D in mm)	M30 x 72,1
Weight	110 g

Electrical Data

Output voltage	24 V DC ±5%
Short-circuit protected	yes

Operating conditions

Operating temperature $T_a$	-5°C ... 55°C (cf. Sec. 4.1)
Storage temperature	-25°C ... 70°C
EMC	This product meets the EMC requirements according to the separately provided Declaration of Conformity.
Vibration/shock	EN 60068-2-6, EN 60068-2-27

Pin assignment

Power (M12, 5-pin socket)		
	Pin	Signal
	1	+24 V
	2	PNP output
	3	GND, 0 V
	4	C/Q, IO-Link, SIO
	5	NC

**Balluff Inductive Coupler System**  
**BIC 1B0-ITA50-M30MF1-SM4A5A (Base)**  
**BIC 2B0-ITA50-M30MF1-SM4A5A (Remote)**

**7 Ordering information**

**Ordering  
information**

<b>Product</b>	<b>Order code</b>
BIC 1B0-ITA50-M30MF1-SM4A5A (Base)	BIC007L
BIC 2B0-ITA50-M30MF1-SM4A5A (Remote)	BIC007E

**[www.balluff.com](http://www.balluff.com)**

Balluff GmbH  
Schurwaldstrasse 9  
73765 Neuhausen a.d.F.  
Germany  
Tel. +49 7158 173-0  
Fax +49 7158 5010  
[balluff@balluff.de](mailto:balluff@balluff.de)

No. 933817-726 EN • 01.126214 • Edition D18 • Replaces Edition B17 • Subject to modifications