

T A B L E O F C O N T E N T S

INSTALLATION SECTION

PART	DESCRIPTION	PAGE
1	<u>PRE-INSTALLATION INFORMATION</u>	
1.1	SITE REQUIREMENTS.....	1.1
1.2	GROUNDING CONDITIONS.....	1.2
1.3	POWER CONDITIONS.....	1.4
1.4	UNPACKING AND INSPECTION.....	1.4
2	<u>INSTALLING CABINETS</u>	
2.1	SYSTEM INSTALLATION PROCEDURE.....	2.1
2.2	SELECTING INSTALLATION METHOD.....	2.1
2.3	INSTALLING IN A RACK.....	2.1
2.4	INSTALLING ON A WALL USING THE TWO PIECE BRACKET KIT.....	2.4
2.5	INSTALLING ON A WALL USING THE BRACKET KIT.....	2.8
2.6	CONNECTING GROUND WIRES.....	2.12
3	<u>INSTALLING AND REPLACING BOARDS</u>	
3.1	CABINET CONFIGURATION.....	3.1
3.2	MP10/MP10a PROCESSOR CARD.....	3.2
3.3	INTERFACE CARDS.....	3.12
3.4	DAUGHTERCARD MODULES.....	3.15
3.5	OTHER INTERFACE CARDS.....	3.22
3.6	CONNECTING POWER FAIL TRANSFER.....	3.37
4	<u>CONNECTING EXTERNAL BATTERIES</u>	
4.1	CONNECTING EXTERNAL BATTERIES.....	4.1
5	<u>CONNECTING POWER</u>	
5.1	BEFORE CONNECTING POWER.....	5.1
5.2	PROCEDURE FOR CONNECTING POWER.....	5.1

6	<u>CONNECTING C.O. LINES</u>	
6.1	<u>SAFETY PRECAUTIONS</u>	<u>6.1</u>
6.2	<u>CONNECTING C.O. LINES</u>	<u>6.2</u>
7	<u>CONNECTING STATIONS AND ADDITIONAL EQUIPMENT</u>	
7.1	<u>CONNECTING STATIONS</u>	<u>7.1</u>
7.2	<u>CONNECTING ADDITIONAL EQUIPMENT</u>	<u>7.23</u>
8	<u>POWER UP PROCEDURES</u>	
8.1	<u>PRE-CHECK.....</u>	<u>8.1</u>
8.2a	<u>STARTING THE SYSTEM (MP10).....</u>	<u>8.1</u>
8.2b	<u>STARTING THE SYSTEM (MP10a).....</u>	<u>8.2</u>
8.2c	<u>UPGRADING MP10 with MP10a CARDS</u>	<u>8.3</u>
8.3	<u>PRECONFIGURED NUMBERING EXTENSIONS AND C.O. LINES</u>	<u>8.3</u>
9	<u>SOFTWARE AND DATABASE MANAGEMENT</u>	
9.1a	<u>SOFTWARE MANAGEMENT WITH MP10 INSTALLED.....</u>	<u>9.1</u>
9.1b	<u>SOFTWARE MANAGEMENT WITH MP10a INSTALLED</u>	<u>9.1</u>
9.2	<u>DATABASE MANAGEMENT</u>	<u>9.2</u>
10	<u>ADDING CARDS TO THE SYSTEM</u>	
10.1	<u>ADDING STATIONS AND TRUNKS.....</u>	<u>10.1</u>

FIGURES

<u>Figure 2.1</u>	<u>Tools Required for Rack Installation</u>
<u>Figure 2.2</u>	<u>Rack Installation (1)</u>
<u>Figure 2.3</u>	<u>Rack Installation (2)</u>
<u>Figure 2.4</u>	<u>Rack Installation (3)</u>
<u>Figure 2.5</u>	<u>Required Tools for Wall Mounting</u>
<u>Figure 2.6</u>	<u>7100 Cabinet Side View--Bracket Angle Out</u>
<u>Figure 2.7</u>	<u>7100 Cabinet with Brackets</u>
<u>Figure 2.8</u>	<u>Mounting the 7100 Cabinet on the Wall</u>
<u>Figure 2.9</u>	<u>Making Holes for Top and Bottom Brackets</u>
<u>Figure 2.10</u>	<u>Hammering Plastic Anchors</u>
<u>Figure 2.11</u>	<u>Side View Wall Mounted 7100 Cabinet</u>
<u>Figure 2.12</u>	<u>Required Tools for the Installation on a Wall</u>
<u>Figure 2.13</u>	<u>Installation on a Wall (1)</u>

- [Figure 2.14 Installation on a Wall \(2\)](#)
- [Figure 2.15 Installation on a Wall \(3\)](#)
- [Figure 2.16 Installation on a Wall \(4\)](#)
- [Figure 2.17 Installation on a Wall \(5\)](#)
- [Figure 2.18 Installation on a Wall \(6\)](#)
- [Figure 2.19 Installation on a Wall \(7\)](#)
- [Figure 2.20 Grounding](#)
- [Figure 3.1 Front/Rear View of OfficeServ 7100 Cabinet](#)
- [Figure 3.2a Switch Setting \(MP10\)](#)
- [Figure 3.2.b Switch Setting \(MP10a\)](#)
- [Figure 3.3 Mounting a Modem Card on the MP10/MP10a](#)
- [Figure 3.4 Mounting a 4SWM or 4DLM on the MP10/MP10a Card](#)
- [Figure 3.4a Real Time Clock Battery \(RTC\)](#)
- [Figure 3.5 Mounting the MP10/MP10a into Slot 0](#)
- [Figure 3.6 Secure the MP10/MP10a into Slot 0](#)
- [Figure 3.7a Front View of the MP10](#)
- [Figure 3.7b Front View of the MP10a](#)
- [Figure 3.8 Installing Interface Cards](#)
- [Figure 3.9 Inserting Interface Card into Slots 1 and 2](#)
- [Figure 3.10 Turning the Cabinet Power Off](#)
- [Figure 3.11 Removing a Card](#)
- [Figure 3.12 Replacing a Card](#)
- [Figure 3.13 Installing the UNI Card](#)
- [Figure 3.14 Front View of UNI Card](#)
- [Figure 3.15 4SWM](#)
- [Figure 3.16 Modem Card](#)
- [Figure 3.17 4TRM](#)
- [Figure 3.18 4DLM](#)
- [Figure 3.19 4SLM](#)
- [Figure 3.20 Setting Switches on the TEPRI/TEPRIa](#)
- [Figure 3.21 Front View of the TEPRI/TEPRIa](#)
- [Figure 3.22 Front View of the 8TRK](#)
- [Figure 3.23 Front View of the 8TRK2](#)
- [Figure 3.24 Front View of the 16TRK](#)
- [Figure 3.25 Front View of the 16DLI2](#)
- [Figure 3.26 Front View of the 8DLI](#)
- [Figure 3.27 Front View of the 8COMBO](#)
- [Figure 3.28 Front View of the 8COMBO2](#)

- [Figure 3.29 Front View of the 16MWSLI](#)
- [Figure 3.30 Front View of the 8SLI](#)
- [Figure 3.31 Front View of the 8SLI2](#)
- [Figure 3.32 Front View of the MGI16](#)
- [Figure 3.33 Front View of the OAS Card](#)
- [Figure 3.34 Example of Power Fail Transfer Connection to 8SLI](#)
- [Figure 4.1 Connecting an External Battery](#)
- [Figure 5.1 Connecting Power](#)
- [Figure 6.1 Tip and Ring Connections to Trunk Cards](#)
- [Figure 6.2 RJ-45 Port of TEPRI/TEPRIa](#)
- [Figure 7.1 RJ-45 Port of the 8SLI](#)
- [Figure 7.2 RJ-45 Port of the 16MWSLI](#)
- [Figure 7.3 RJ-45 Port of the 8COMBO/8COMBO2 \(For Analog Phone\)](#)
- [Figure 7.4 RJ-45 4SLM Port on the UNI Card](#)
- [Figure 7.5 RJ-45 4DLM Port on the UNI Card](#)
- [Figure 7.6 RJ-45 Port of the 8DLI \(For Digital Phone\)](#)
- [Figure 7.7 RJ-45 Port of the 16DLI2 \(For Digital Phone\)](#)
- [Figure 7.8 RJ-45 Port of 8COMBO/8COMBO2 \(For Digital Phone\)](#)
- [Figure 7.9 LAN Connections](#)
- [Figure 7.10 Connecting a Door Phone and a Door Lock](#)
- [Figure 7.11 Adding an iDCS KDBF Keypad Daughtercard Module](#)
- [Figure 7.12 Wall-Mounting an iDCS Keypad](#)
- [Figure 7.13 Wall-Mounting DS 5000, ITP-5121D and ITP-5107S Keypads](#)
- [Figure 7.14 Attaching iDCS 64 Button Module to an iDCS Keypad](#)
- [Figure 7.15 Attaching iDCS 14 Button Module to an iDCS Keypad](#)
- [Figure 7.16 Attaching DS 64 Button Modules to a DS5021D or a DS5014D Keypad](#)
- [Figure 7.17 Attaching SMT-i5264 AOM to Phone](#)
- [Figure 7.18 Setting-Up SMT-i5264 AOM](#)
- [Figure 7.19 IP AOM Network Configuration](#)
- [Figure 7.20 Connecting Access Point to Ethernet Port](#)
- [Figure 7.21 Connecting MOH/BGM Sources](#)
- [Figure 7.22 Connecting External/Additional Page Equipment](#)
- [Figure 7.23 Connecting Common Bells](#)
- [Figure 7.24 OIT Connection to LAN Port](#)
- [Figure 7.25 OIT and LAN Connection](#)
- [Figure 7.26 OIT and Modem Connection](#)
- [Figure 7.27 Connecting SMDR](#)
- [Figure 7.28 Connecting to Printer](#)

[Figure 8.1 iDCS 28 Button Line Key Default](#)

[Figure 8.2 iDCS 18 Button Line Key Default](#)

TABLES

[Table 1.1 Power Specifications](#)

[Table 3.1 Card Installation Configuration](#)

[Table 3.2 Parts on the Rear Panel of the Cabinet](#)

[Table 3.3a Ports and LEDs of the MP10](#)

[Table 3.3b Ports and LEDs of the MP10a](#)

[Table 3.4 UNI Card Ports and LEDs](#)

[Table 3.5 Ports and LEDs of the TEPRI/TEPRIa](#)

[Table 3.6 Ports and LEDs of the 8TRK](#)

[Table 3.7 Ports and LEDs of the 16TRK](#)

[Table 3.8 Ports of the 16DLI2](#)

[Table 3.9 Ports and LEDs of the 8DLI](#)

[Table 3.10 16MWSLI Ports](#)

[Table 3.11 Ports and LEDs of the 8SLI/8SLI2](#)

[Table 3.12 MGI16 Front Panel Components](#)

[Table 3.13 OAS Front Panel Components](#)

[Table 6.1 OfficeServ 7100 Line Conditions](#)

[Table 7.1 Distance Between Stations and the System](#)

[Table 7.2 Specification for Wireless LAN Connection](#)

[Table 7.3 Installation Tool Specification](#)

PART 1. PRE-INSTALLATION INFORMATION

1.1 SITE REQUIREMENTS

Select a location that satisfies the following conditions for safety, temperature, humidity, power and grounding.

1.1.1 Safety Conditions

- The OfficeServ 7100 system should not be installed near materials that can cause a fire, such as explosive gas and inflammables. The OfficeServ 7100 system should not be near equipment that generates electromagnetic waves, such as monitors or copying machines.
- The installation location should be convenient for distributing trunk lines and extension lines, for connecting power and grounding wires, and for maintenance and repair.
- The OfficeServ 7100 system should not be installed in aisles or passageways that are populated or used for moving equipment.
- Always maintain cleanliness to prevent dust from damaging the card connectors of the cabinet.
- Before installing the OfficeServ 7100 system, check items such as the electrical wiring status, grounding status, voltage and frequency.
- Do not expose equipment to direct sunlight, corrosive fumes, and constant vibrations.
- Do not install in close proximity to a fire sprinkler or other sources of water.
- A dedicated commercial AC power outlet is required. Do not use extension cords.
- Ensure that all wires and cables to and from the OfficeServ 7100 do not cross fluorescent lights or run in parallel with AC wires.
- This equipment is to be installed only in restricted access areas (dedicated, equipment closets, etc.) in accordance with articles 110-16, 110-17, 110-18 of the National Electric Code, ANSI/NFPA 70.

1.1.2 Temperature/Humidity Conditions

The conditions for temperature and humidity are as follows:

- Operation temperature: 32°F~113°F
- Storage temperature: 14°F~122°F
- Humidity: 10~90%

1.2 GROUNDING CONDITIONS

An equipment grounding conductor that is not smaller in size than the ungrounded branch-circuit supply conductors is to be installed as part of the circuit that supplies the product or system. Bare, covered, or insulated grounding conductors are acceptable. Individually covered or insulated equipment grounding conductors shall have a continuous outer finish that is either green or green with one or more yellow stripes. The equipment grounding conductor is to be connected to ground at the service equipment.

The attachment-plug receptacles in the vicinity of the product or system are all to be of a grounding type, and the equipment grounding conductors serving these receptacles are to be connected to earth ground at the service equipment.

WARNING: HIGH LEAKAGE CURRENT! Earth connection is essential before connecting supply.

The OfficeServ 7100 system requires that a supplementary earth ground be connected to the system. This is the preferred method of grounding the OfficeServ 7100. It should be noted that when the third wire ground becomes inferior it may prevent the digital data bus from canceling out noise. This may result in erratic operation of the OfficeServ 7100. Another problem that has occurred is that some UPS battery systems do not pass the ground through to the power cord resulting in no ground to the system. The ground lug in the back of the cabinet must be connected to one of the following: bonded building steel, cold water pipe or a ground rod using at least #16 AWG copper wire. The third wire AC ground or Field Ground is connected to the system frame via the ground strap from the ground connector on the AC socket.

A supplementary equipment grounding conductor shall be installed between the system and ground that is in addition to the equipment grounding conductor in the power supply cord.

The supplementary equipment grounding conductor shall not be smaller in size than the ungrounded branch-circuit supply conductors. The supplementary equipment grounding conductor shall be connected to the product at the terminal provided, and shall be connected to ground in a manner that will retain the ground connection when the product is unplugged from the receptacle. The connection to ground of the supplementary equipment grounding conductor shall be in compliance with the rules for terminating bonding jumpers in Part K of Article 250 of the National Electrical Code ANSI/NFPA 70 and Article 10 of Part 1 of the Canadian Electrical Code, Part 1, C22.1. Termination of the supplementary equipment grounding conductor is permitted to be made to building steel, to a metal electrical raceway system, or to any grounded item that is permanently and reliably connected to the electrical service equipment ground.

Bare, covered, or insulated grounding conductors are acceptable. A covered or insulated grounding conductor shall have a continuous outer finish that is either green or green with one or more yellow stripes.

Failure to provide an adequate ground may cause a safety hazard, confusing trouble symptoms or even circuit card failure.

WARNING: Unplug the power cord from the AC outlet before attempting to connect the ground. Hazardous voltage may cause death or injury. Observe extreme caution when working with AC power. Remove lines from trunk cards.

What the above paragraphs mean is that when conventional analog telephone circuits are connected to the OfficeServ 7100 system, under fault conditions (i.e., the tip and/or ring conductor is crossed with a power line, or the circuit is affected by lightning during a storm), it is possible for hazardous potentials to appear across the tip and ring wiring coming into the OfficeServ 7100 cabinet from the outside plant (i.e., overhead cables, buried cables, cable head pedestal). These circuits are provided with both primary and secondary protection circuitry which will attempt to drain off these high voltages and currents to earth ground. Obviously, it is important to have a good source of ground connected to the OfficeServ 7100 system to drain this energy off. Again, a good earth ground source is required by the OfficeServ 7100 system.

The OfficeServ 7100 system has two ground reference points. One point is via the green wire in the power cord connected to the AC power outlet. This ground connection is provided to meet local electrical codes when the AC ground is required to be common with the earth ground. However, this can be disconnected either intentionally or unintentionally. Consequently, a more permanent ground connection is required by connecting a high current/voltage capacity ground wire which is bonded to ground at the electric service power entrance or via some other method approved by the National Electrical Code to the OfficeServ 7100 system ground lug. This is a more secure ground connection, which can only be disconnected intentionally. These precautions are taken for safety reasons to protect personnel working on the OfficeServ 7100 system and also for operational reasons to accommodate ground return and/or ground-referenced analog telephone circuits, which require this solid earth ground connection for normal functioning.

1.3 POWER CONDITIONS

The power supply card of the OfficeServ 7100 system receives AC input power or battery power, and supplies -48V, -5V, +5V, +3.3V, +12V, and -54V (Battery Backup) to the system cabinet.

The rating is as follows:

- RATING: AC 110-120V; 3A; 50/60Hz or DC -48V 3A

Table 1.1 Power Specifications

Power Supply Unit(PSU)		Specification
PSU	Input power	AC 110V DC 48V (-48VDC, 3A for battery backup ONLY)
	Output power	- DC -54V, 1.1A - DC +5V, 5.0A - DC -5.3V, 0.3A - DC +3.3V, 5A - DC +12V, 0.4A - DC -54V, 0.25A (for battery backup)
Power Consumption	105 Watts	

1.4 UNPACKING AND INSPECTION

The OfficeServ 7100 can only be configured as a single cabinet system.

After unpacking the cabinet, inspect for signs of physical damage. If any damage is detected, do not attempt to install the system. Contact Samsung Telecommunications America Technical Support Department.

Check to see that each cabinet carton includes the following:

- OfficeServ 7100 cabinet
- AC Power Cable
- Wall mount plate
- Screw Pack
- Battery Cable Assembly
- Blanking Plates (1)

PART 2. INSTALLING CABINETS

This section describes how to install an OfficeServ 7100 cabinet on a table/desktop in a data rack or on a wall, depending on the installation environment.

2.1 SYSTEM INSTALLATION PROCEDURE

The procedure of system installation is as follows.

- 1) Install the OfficeServ 7100 cabinet on a table, inside a data rack or on the wall depending on the installation environment.
- 2) Connect the ground to the ground lug located in the back of the cabinet.
- 3) Install the MP10/MP10a card into slot 0 of the cabinet.
- 4) Install interface cards or UNI cards (with the required daughtercards modules installed on them) into universal slots (slots 1 or 2) of the cabinet.
- 5) Connect an external battery with proper capacity if required.
- 6) Connect AC 110V input power.

2.2 SELECTING INSTALLATION METHOD

The OfficeServ 7100 cabinet can be installed on a table, inside a 19-inch rack or on a wall depending on the installation environment or customer requirements.

2.3 INSTALLING IN A RACK

2.3.1 Cautions for Installation

Take the following precautions when installing the OfficeServ 7100 cabinet inside a rack:

- The 19-inch rack should be a standard equipment rack.
- When using an enclosed-type rack, check if the rack is properly ventilated. Vents should be equipped on the side of the rack and fans should be attached to ventilate cool air into the rack.
- Take special caution when using an enclosed-type rack that has vents on top of the rack since hot air coming out of the vent may enter the intake vent of a system installed above the rack.
- When using an open rack, do not block the entrance of a port or the OfficeServ 7100 fan.

2.3.2 Required Tools

- A mid-sized Phillips screwdriver
- Two brackets and six screws for attaching rack
- Two clamp screws

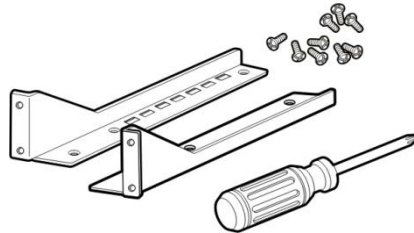

Figure 2.1 Tools Required for Rack Installation

2.3.3 Installing in a Rack

The procedure for installing the OfficeServ 7100 cabinet inside a 19-inch rack is as follows (NOTE: The optional rack mount kit is required for this method. This kit is sold separately):

- 1) Attach the cabinet bracket to the bottom surface of the OfficeServ 7100 cabinet and fasten the bracket firmly with the two screws.

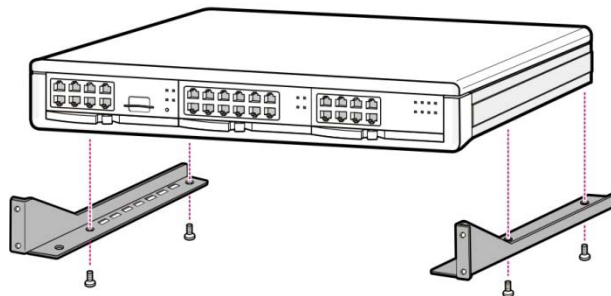

Figure 2.2 Rack Installation (1)

- 2) Slide the cabinet attaching the bracket in step 1.

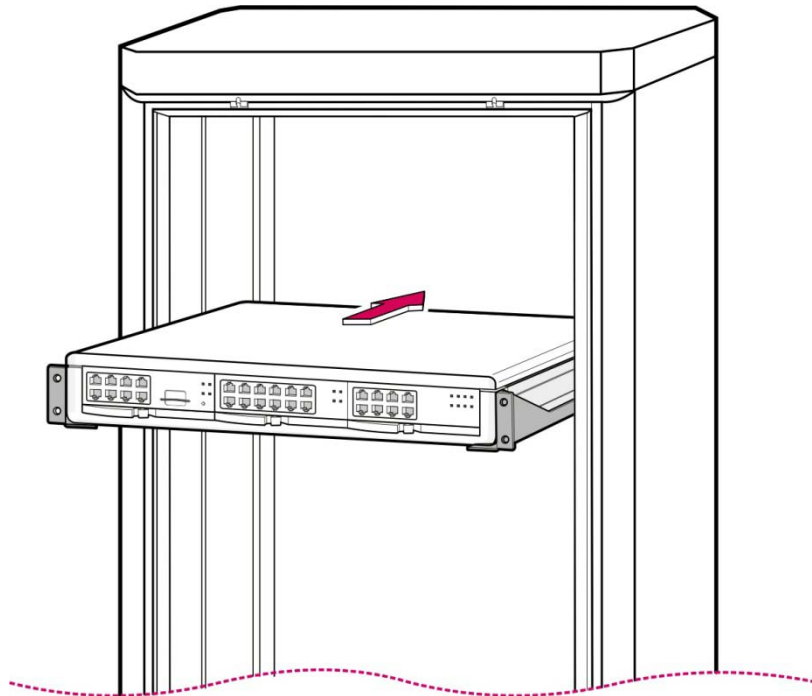

Figure 2.3 Rack Installation (2)

- 3) Align the two holes of the cabinet bracket and the holes of the rack brackets, and fasten the cabinet to the rack with the two screws.

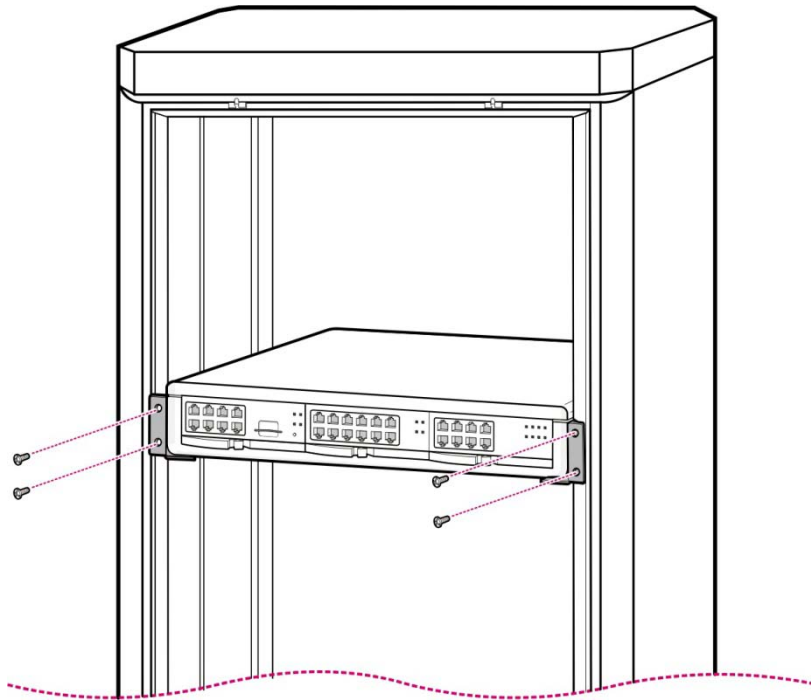

Figure 2.4 Rack Installation (3)

2.4 INSTALLING ON A WALL USING THE TWO PIECE BRACKET KIT

This section describes how to install the OfficeServ 7100 cabinet on a wall. The OfficeServ 7100 wall mount bracket is required (included with the cabinet).

2.4.1 Required Tools

- ① Four plastic anchors
- ② Four cross-type screws (shorter)
- ③ Four locking screws (longer)

Mid-sized Phillips screw driver

Electric drill

Hammer

Wall-mount bracket



Figure 2.5 Required Tools for Wall Mounting

2.4.2 Wall Installation

CAUTION: Only mount OfficeServ 7100 onto a wall capable of supporting the 7100 cabinet, associated blocks, cables and peripheral equipment.

- 1) Turn the 7100 cabinet onto its bottom side. Using the four short screws, install the two wall mount brackets to the bottom of the cabinet. *The wall mount brackets must be correctly installed onto the cabinet with the star shaped holes angled out away from the cabinet as shown below.*



Figure 2.6 7100 Cabinet Side View—Bracket Angle Out

- 2) Using the four (shorter) screws screw both wall mount brackets in the proper direction securely onto the bottom of the cabinet.



Figure 2.7 7100 Cabinet with Brackets

- 3) Hold the 7100 cabinet against the wall in the desired direction. There are four (plus + shaped) holes on the top and bottom of the bracket (see positions marked A in the figure below). Mark the top two holes on the desired wall then mark the two holes on the bottom brackets.



Figure 2.8 Mounting the 7100 Cabinet on the Wall

- 4) Using a 3/16" drill bit, make holes on the marked positions of the top and bottom brackets.



Figure 2.9 Making Holes for Top and Bottom Brackets

- 5) With a hammer, drive the plastic anchors into the drilled holes.



Figure 2.10 Hammering Plastic Anchors

- 6) Align the screw holes of the wall mount bracket to the position that the plastic anchors are driven. Insert the remaining (longer) screws to each hole and tighten the screws with a Phillips screw driver.



Figure 2.11 Side View Wall Mounted 7100 Cabinet

2.5 INSTALLING ON A WALL USING THE BRACKET KIT

This section describes how to install the OfficeServ 7100 cabinet on a wall. The OfficeServ 7100 wall mount bracket is required (included with the cabinet).

2.5.1 Required Tools

- Mid-sized Phillips screw driver
- Electric drill
- Hammer
- Wall-mount bracket
- Four plastic anchors
- Four cross-type screws
- Four mount locking screws

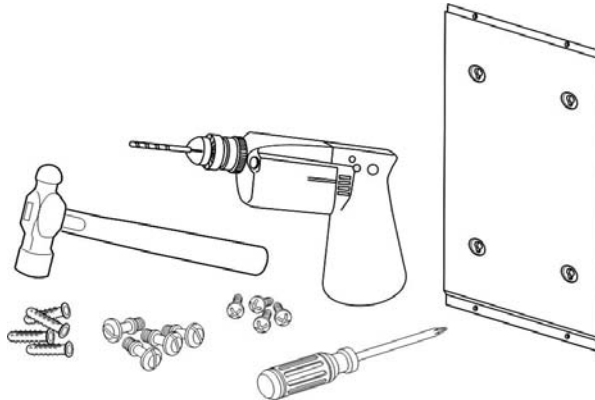

Figure 2.12 Required Tools for the Installation on a Wall

2.5.2 Wall Installation

CAUTION: Only mount OfficeServ 7100 onto a wall capable of supporting the 7100 cabinet, associated blocks, cables and peripheral equipment.

- 1) There are four holes for the screws on the top/bottom of the bracket (see positions marked 'A' in the figure below). Mark four holes on a desired wall by using the bracket.

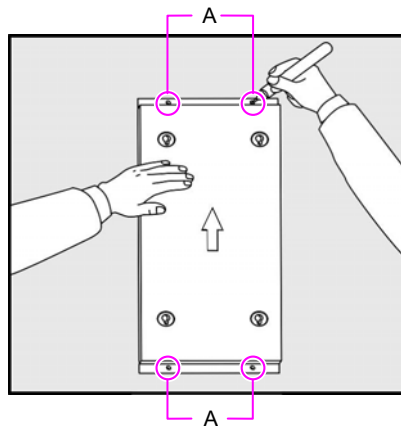

Figure 2.13 Installation on a Wall (1)

- 2) Make holes on the marked positions of the wall mount bracket. Make the depths and the diameters of the holes more than 35mm and around 5.5mm such that the plastic anchors can be inserted.

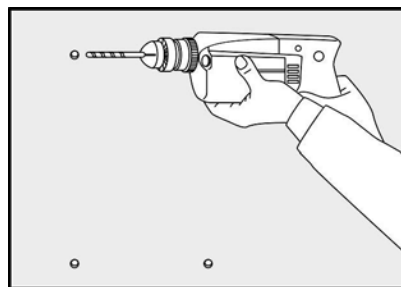

Figure 2.14 Installation on a Wall (2)

- 3) With a hammer, drive plastic anchors into the drilled holes.

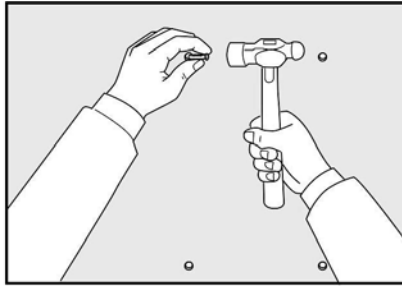

Figure 2.15 Installation on a Wall (3)

- 4) Align the screw holes of the wall mount bracket to the position that the plastic anchors are driven. Insert screws to each hole and tighten the screws with a Phillips screw driver.

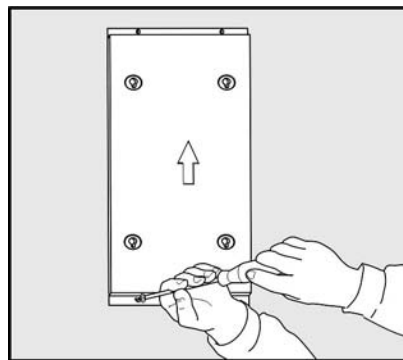

Figure 2.16 Installation on a Wall (4)

- 5) Two screws exist in the two screw holes among the four screw holes on the bottom side of the OfficeServ 7100 cabinet. Unscrew the two screws to a height of about 2mm.

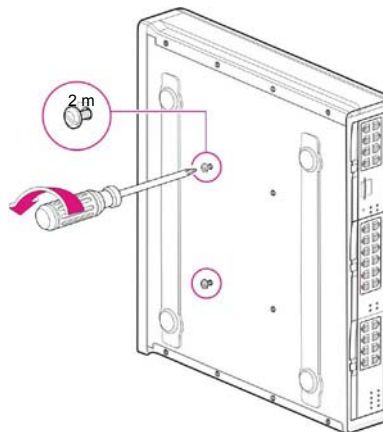

Figure 2.17 Installation on a Wall (5)

- 6) Tighten the mount locking screws into the remaining two holes along the four screw holes on the bottom of the OfficeServ 7100 cabinet. At this point, do not tighten completely, but keep the screws out about 2mm.

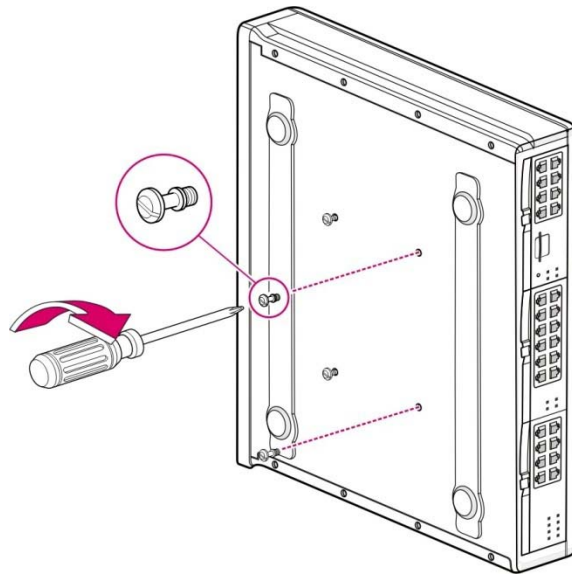

Figure 2.18 Installation on a Wall (6)

- 7) Align the screws on the bottom of the OfficeServ 7100 cabinet to the bracket holes, then pull down the cabinet to lock the cabinet securely.

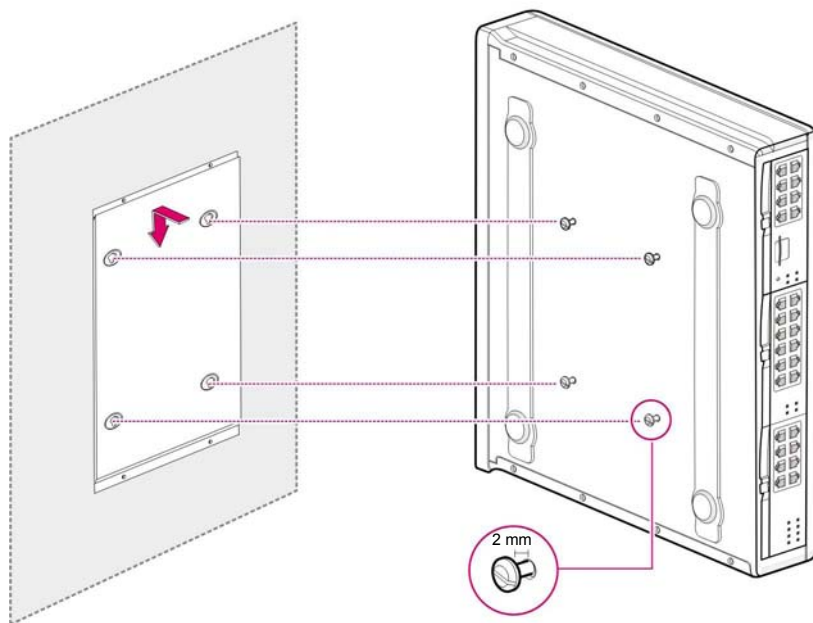

Figure 2.19 Installation on a Wall (7)

2.6 CONNECTING GROUND WIRES

This section describes how to connect an external grounding wire to the OfficeServ 7100 system.



External Grounding

External grounding is required to prevent human injuries and system damage caused by lightning, static electricity, or voltage surge. The OfficeServ 7100 must be grounded with a grounding wire that has a thickness more than **4.0mm²**.

As shown in the figure below, connect an earth ground to the ground lug behind the OfficeServ 7100.

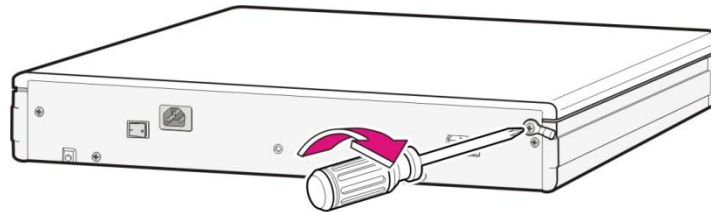

Figure 2.20 Grounding

IMPORTANT: Follow the grounding requirements described in Section 1.2 (Grounding Conditions) when connecting a ground to the system.

PART 3. INSTALLING AND REPLACING CARDS

This section describes how to install and replace various cards of the OfficeServ 7100 system.

3.1 CABINET CONFIGURATION

The OfficeServ 7100 system has 3 slots (slots 0~2). Slot 0 is a processor slot only used for either the MP10/MP10a processor card. Slots 1 and 2 are universal slots for station and trunk interface cards as described below.

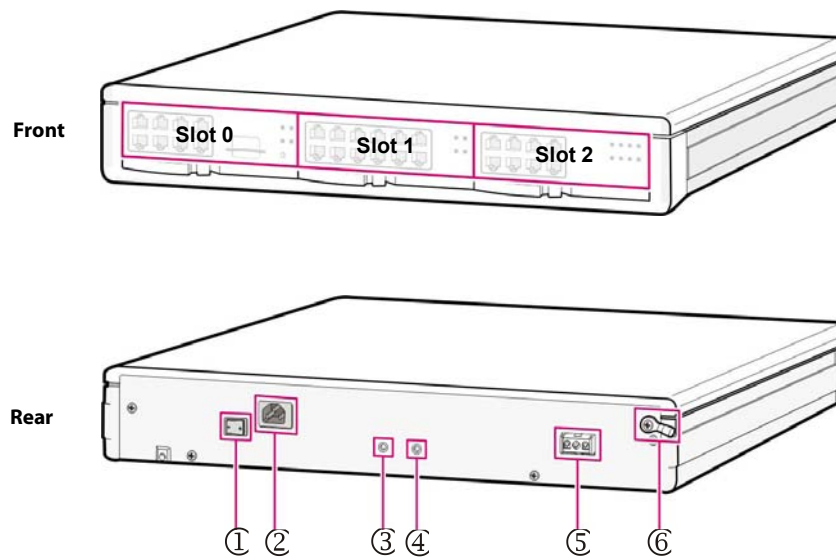

Figure 3.1 Front/Rear View of OfficeServ 7100 Cabinet

Following cards are allowed to be installed in the 7100 as shown below:

NOTE: ONLY THESE CARDS ARE ALLOWED IN THE SPECIFIED SLOTS. ALL OTHER CARDS ARE NOT ALLOWED IN THE OS7100 SYSTEM.

Table 3.1 Card Installation Configuration

Slot	Cards Allowed
Slot 0 (processor slot)	MP10/MP10a ONLY

Slot	Cards Allowed
Slot 1 and Slot 2 (universal slots)	- OS7100 Card allowed: UNI cards - OS7200/OS7400 Cards allowed: 8DLI, 16DLI2, 8SLI, 16MWSLI, 8COMBO/8COMBO2, 8TRK, 8TRK2, 16TRK, TEPRIa, MGI-16

NOTE: The OfficeServ 7100 only supports PRI service and does not support T1 service even though the TEPRI and TEPRIa cards support both.

The descriptions about each part on the rear of the cabinet are listed in the table below.

Table 3.2 Parts on the Rear Panel of the Cabinet

Part	Function
① Power Switch	Power on/off switch for the OfficeServ 7100 system.
② AC Power connector	Connector for the power cable connection
③ AC LED	The LED indicates the input of AC power.
④ DC LED	The LED indicates the normal output of DC power.
⑤ Battery Socket	Connector for an external battery
⑥ Ground Lug	Connection for system ground cable.

3.2 MP10/MP10a PROCESSOR CARD

This section describes the procedures for setting switches and installing optional daughter cards on the MP10/MP10a as well as installing the MP cards in the processor slot.

The OfficeServ 7100 MP10/MP10a (Main Control Processor) controls the system operation. The MP10/MP10a is required for all configurations and goes only in slot 0 of the cabinet.

The MP10/MP10a comes standard with a built-in 4 port Voice Mail/Auto Attendant and 8 VoIP MGI (Media Gateway Interface) channels. The MGI features and capacities are controlled by license keys entered in system programming.

NOTE: This manual covers the installation and startup of both the MP10 and MP10a processor cards. Take note that the SD media cards are different and they are not compatible. Verify that the MP10 MMC+/SD card is installed in the MP10 and the MP10a SD card is installed in the MP10a.

3.2.1a Setting Switches on MP10

On the MP10 set the switches for the required configuration. The description for the settings is described below.

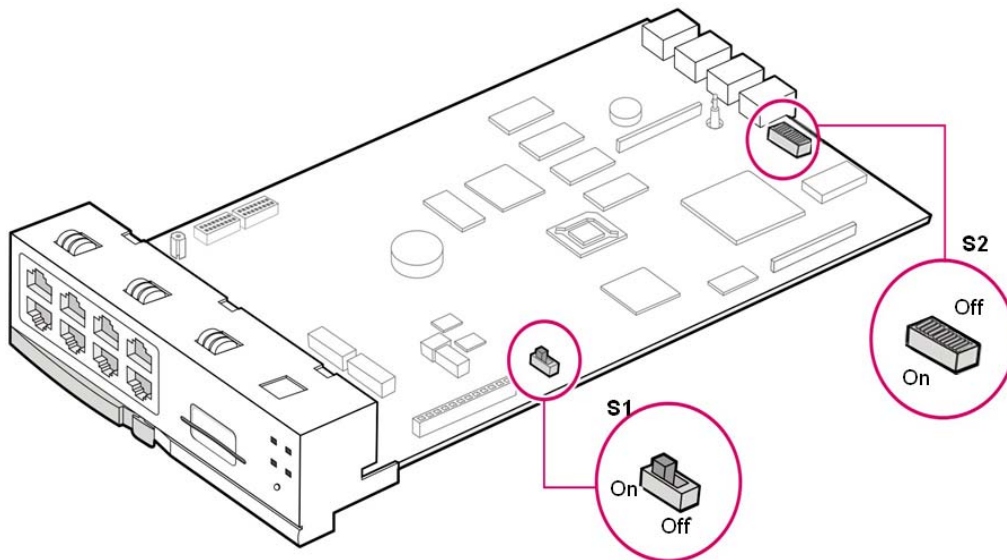

Figure 3.2a Switch Setting (MP10)

- **Memory Backup Switch (S1):** When set to ON, all system programming is saved in SRAM even when system is rebooted or powered OFF. This will be saved in SRAM until the Super Capacitor has been drained of all charge (this charge will last only up to 24 hours with system power OFF). At that point all programming will be lost. It is recommended that all programming is saved to the MP10 MMC+/SD card or to a PC using the OfficeServ Installation Tool application. Turning the switch (S1) OFF will set the system to DEFAULT. To default the system, keep this switch (S1) in the OFF position for 30 seconds. Switch to ON position before powering up the system.

Note: The S2 dip switches are set properly by the factory for a 3-digit numbering plan and the country of USA. These dip switches should be left at default and should never be changed. If a 4-digit numbering plan is required, the numbering plan should be changed in the software by using MMC 724.

DIP SWITCH USE (S2)

ON (left)		OFF (right)
4 DIGIT STATION NUMBERS	SW8	3 DIGIT STATION NUMBERS
4 DIGIT STATION GROUPS	SW7	3 DIGIT STATION GROUPS
4 DIGIT TRUNK NUMBERS	SW6	3 DIGIT TRUNK NUMBERS
RESERVED	SW5	RESERVED
COUNTRY SELECT	SW4	COUNTRY SELECT
COUNTRY SELECT	SW3	COUNTRY SELECT
COUNTRY SELECT	SW2	COUNTRY SELECT
COUNTRY SELECT	SW1	COUNTRY SELECT

- Switches 1 through 4 select the country the system is installed in.

4	3	2	1	Country
OFF	OFF	OFF	OFF	Korea
OFF	OFF	OFF	ON	USA
OFF	OFF	ON	OFF	UK
OFF	OFF	ON	ON	Italy
OFF	ON	OFF	OFF	Australia
OFF	ON	OFF	ON	New Zealand
OFF	ON	ON	OFF	Holland
OFF	ON	ON	ON	Denmark

- Switch 5 is reserved.
- These DIP switches will not take effect unless the switches are set in the wanted position and the system memory is cleared manually by using the Memory Backup switch.

3.2.1b Setting Switches on MP10a

On the MP10a set the switches for the required configuration. The description for the settings is described below.

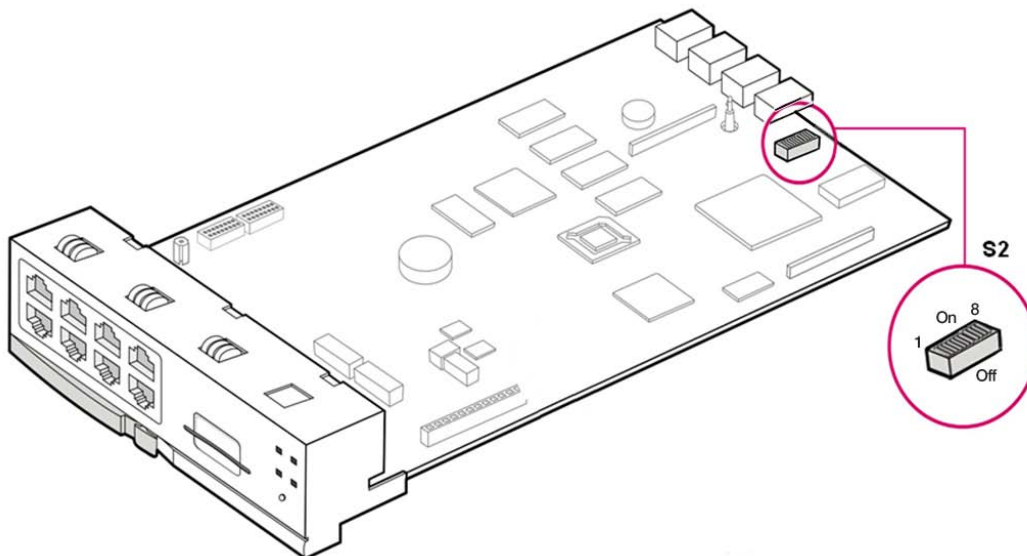

Figure 3.2b Switch Setting (MP10a)

- Memory Backup Switch (S1): There is no memory backup switch on the MP10a card. All the system programming is saved by NAND flash even when the system is restarted or powered off. System programming is saved in NAND flash indefinitely until the system is defaulted. It is recommended that all system programming be periodically saved to the MP10a SD card or to a PC using the OfficeServ Installation Tool Application. To default the system programming on the MP10a card, press and hold in the RST (reset) switch for 7 to

10 seconds during the bootup sequence or during live operation. When the boot up sequence is complete in about 3 to 5 minutes, the system's database will be defaulted.

Note: The S2 dip switches are set properly by the factory for a 3-digit numbering plan and the country of USA. These dip switches should be left at default and should never be changed. If a 4-digit numbering plan is required, the numbering plan should be changed in the software by using MMC 724.

DIP SWITCH USE (S2)

ON (left)		OFF (right)
4 DIGIT STATION NUMBERS	SW8	3 DIGIT STATION NUMBERS
4 DIGIT STATION GROUPS	SW7	3 DIGIT STATION GROUPS
4 DIGIT TRUNK NUMBERS	SW6	3 DIGIT TRUNK NUMBERS
RESERVED	SW5	RESERVED
COUNTRY SELECT	SW4	COUNTRY SELECT
COUNTRY SELECT	SW3	COUNTRY SELECT
COUNTRY SELECT	SW2	COUNTRY SELECT
COUNTRY SELECT	SW1	COUNTRY SELECT

- Switches 1 through 4 select the country the system is installed in.

4	3	2	1	Country
OFF	OFF	OFF	OFF	Korea
OFF	OFF	OFF	ON	USA
OFF	OFF	ON	OFF	UK
OFF	OFF	ON	ON	Italy
OFF	ON	OFF	OFF	Australia
OFF	ON	OFF	ON	New Zealand
OFF	ON	ON	OFF	Holland
OFF	ON	ON	ON	Denmark

- Switch 5 is reserved.
- These DIP switches will not take effect unless the switches are set in the wanted position and the system memory is cleared manually by using the Memory Backup switch.

3.2.2 Installing Optional Daughtercards on the MP10/MP10a

Three (3) types of optional daughtercards can be installed on the MP10/MP10a:

- Optional modem daughtercard (installed in the connector located towards the back of the MP10/MP10a)
- The optional 4SWM PoE LAN daughtercard (installed in the connector located towards the front of the MP10/MP10a)

3) The optional 4DLM daughtercard (installed in the connector located towards the front of the MP10/MP10a)

The optional modem daughtercard is mounted to connector P7 of the MP10/MP10a card. This modem daughtercard allows remote dial up connection to the system for system administration and configuration. This is an alternative method for connecting to the system when a LAN/WAN connection is unavailable. The modem board has the following functions:

- The MP10/MP10a board supports a 2-Wire Full Duplex modem board. This is the same modem used on the OfficeServ 500 system.
- The modem board operates in OfficeServ 7100 via V.24 interface. In addition, the modem board supports V.90 protocol. OfficeServ 7100 controls the modem board via serial communication using standard AT commands. When mounting a modem card, the holes on the corners of the modem should be aligned such that the spacer fits in the hole in the following figure.

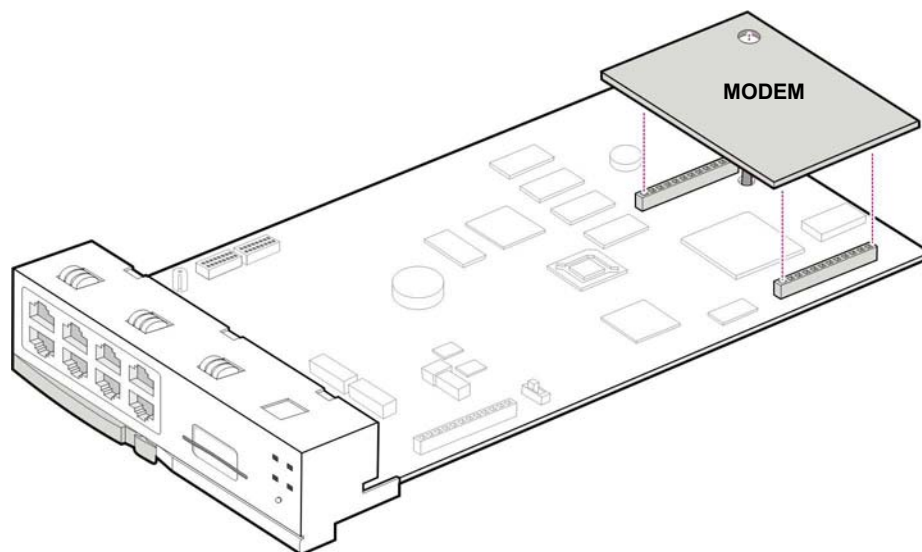

Figure 3.3 Mounting a Modem Card on the MP10/MP10a

The 4SWM (optional 4 port POE LAN module) or 4DLM (optional 4 port Digital Line module) daughtercards can be mounted to connector P11, P12 and P13 of the MP10/MP10a card. A screw is installed to the support located next to connector P13. Remove this screw, install the daughtercard and install the screw to secure the card as shown below.

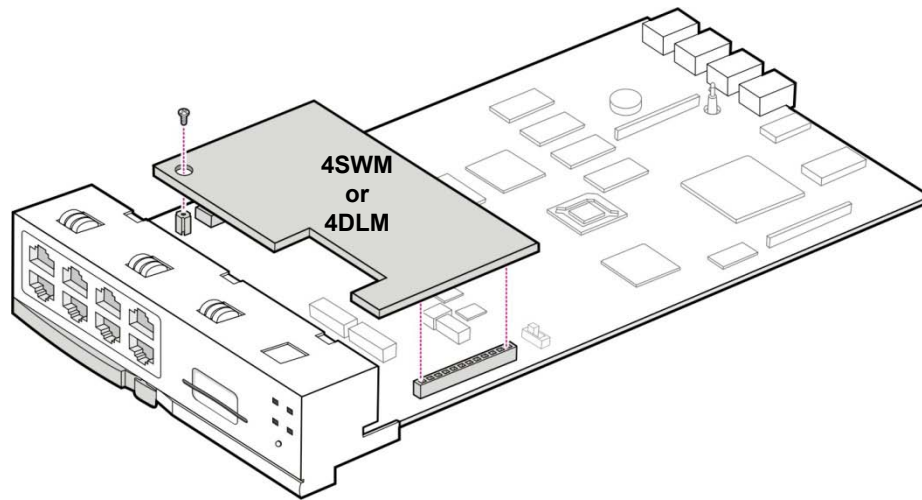

Figure 3.4 Mounting a 4SWM or 4DLM on the MP10/MP10a Card

A small battery is added to the MP10a card that is called the RTC (real-time clock). The purpose of the battery is to maintain the time, date and day of week information in memory during system powered off conditions. This insures that the time and date in the display keyset is always up to date even after powering off or rebooting.

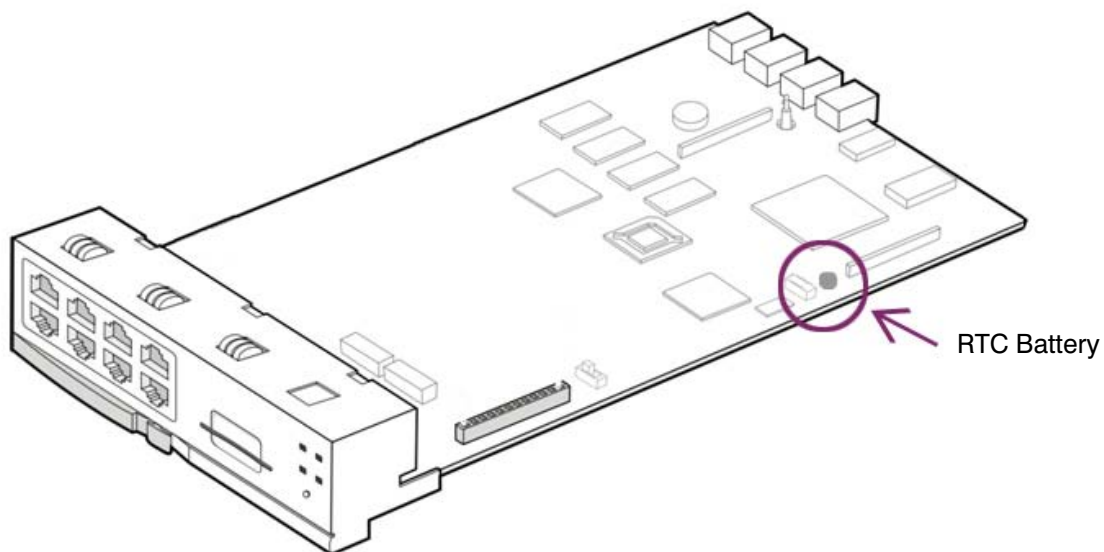

Figure 3.4a Real Time Clock Battery (RTC)

3.2.3 Installing MP10/MP10a

Install processor card (MP10/MP10a) in slot 0. The locations of slot 0 through slot 2 are described in Figure 3.1.

- 1) Check the exterior of the MP10/MP10a card for any damage. If damage is found, do not proceed with installation. Contact Samsung Technical Support.



Power the system OFF when installing or removing cards. POWER TO THE CABINET MUST BE TURNED OFF. Failure to do so will damage the card, cabinet and/or corrupt the data moving along the data bus.

- 2) Align the MP10/MP10a card to the guardrail of slot 0 and carefully slide it in.

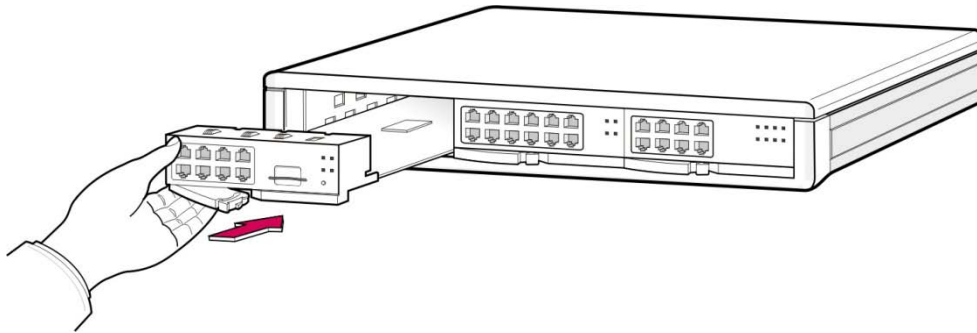

Figure 3.5 Mounting the MP10/MP10a into Slot 0

- 3) Press and lock the lever to fully insert into the slot.

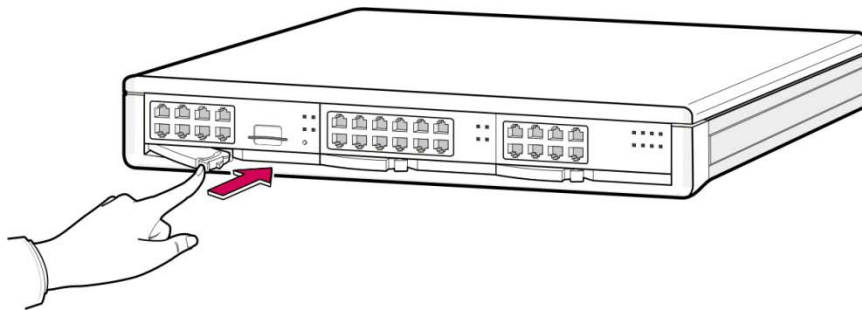

Figure 3.6 Secure the MP10/MP10a into Slot 0

3.2.4a MP10 LEDs

The front view of the MP10 card is shown in the picture below.

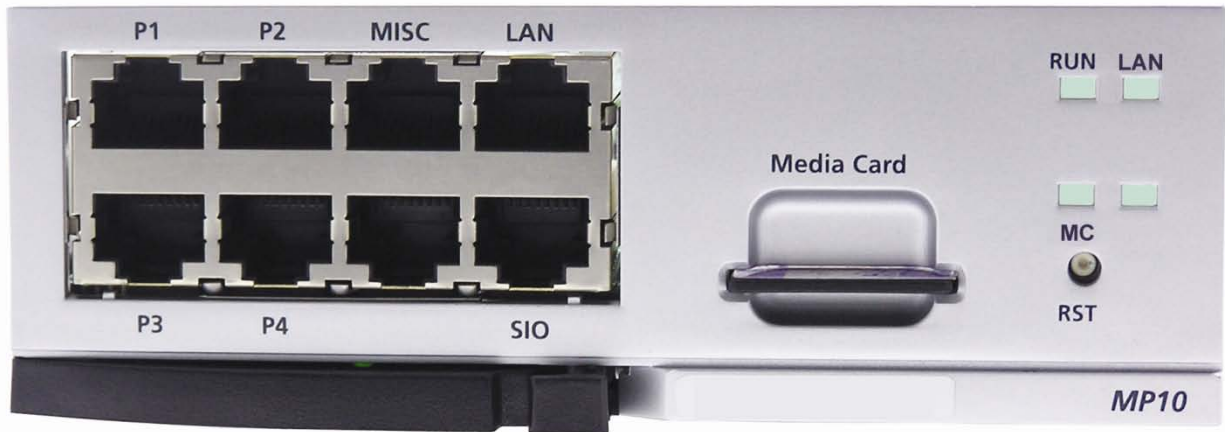

Figure 3.7a Front View of the MP10

The MP10 front panel components have the functions below:

Table 3.3a Ports and LEDs of the MP10

Ports & LEDs	Function Description
P1~P4 Ports	Connection ports for the 4DLM or 4SWM daughtercards when installed on the MP10.
MISC Port	Port that connects external MOH/BGM sources, paging device, loud bell or common bell.
Media Card	Slot for installing the MP10 MMC+/SD media storage card. This card contains the main system software, system configuration database, and voicemail greetings and messages.
LAN Port	Port for establishing the 10 Base-T/100 Base-Tx Ethernet connection. This allows the MP10 to be connected to a data network.
SIO Port	Serial port (Samsung Use ONLY).
RST Button	Button for resetting the MP10 card.
RUN LED	This LED indicates the status of the main CPU operation. - Off: Power is not connected. - On (Green): Booting, reset. - Blink (Green): The program is operating properly.
LAN LED	This LED indicates the status of the connection to LAN. - Off: MP10 is not connected to LAN. - On (Green): MP10 is connected LAN. - Blink (Green): MP10 is transmitting or receiving data through LAN port.

Ports & LEDs	Function Description
MC LED	<p>This LED indicates the status of the MP10 MMC+/SD card access.</p> <ul style="list-style-type: none"> - Off: The MP10 MMC+/SD card is not installed. - On: The MP10 MMC+/SD card is installed, however, is not being accessed. - Blink: The MP10 MMC+/SD card is installed and is being accessed.

3.2.4b MP10a LEDs

The front view of the MP10a card is shown in the picture below.

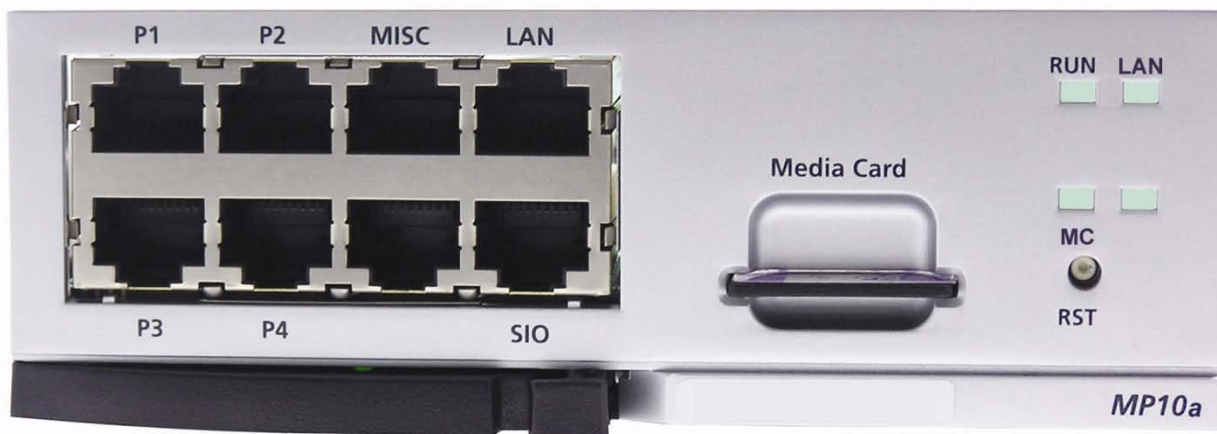

Figure 3.7b Front View of the MP10a

The MP10a front panel components have the functions below:

Table 3.3b Ports and LEDs of the MP10a

Ports & LEDs	Function Description
P1~P4 Ports	Connection ports for the 4DLM or 4SWM daughtercards when installed on the MP10a.
MISC Port	Port that connects external MOH/BGM sources, paging device, loud bell or common bell.
Media Card	Slot for installing the MP10a SD media storage card. This card contains the main system software, system configuration database, and voicemail greetings and messages.
LAN Port	Port for establishing the 10 Base-T/100 Base-Tx Ethernet connection. This allows the MP10a to be connected to a data network.
SIO Port	Serial port (Samsung use ONLY).
RST Button	Button for resetting the MP10a card.

Ports & LEDs	Function Description
RUN LED	This LED indicates the status of the main CPU operation. - Off: Power is not connected. - On (Green): Booting, reset. - Blink (Green): The program is operating properly.
LAN LED	This LED indicates the status of the connection to LAN. - Off: MP10a is not connected to LAN. - On (Green): MP10a is connected LAN. - Blink (Green): MP10a is transmitting or receiving data through LAN port.
MC LED	This LED indicates the status of the MP10a SD card access. - Off: The MP10a SD card is not installed. - On: The MP10a SD card is installed, however, is not being accessed. - Blink: The MP10a SD card is installed and is being accessed.

Note: The write protection switch of the MP10a SD card must always remain in the unlocked position. Placing the MP10a SD write protect in the locked position will cause voicemail misoperation and/or system resets.

3.3 INTERFACE CARDS

This section describes how to set jumpers and switches of an interface card, how to install optional daughtercards to an interface card, and how to install interface cards into slots.

3.3.1 Installing Interface Cards

Interface cards are installed in slot 1 and slot 2 of the cabinet. [Refer to Table 3.1](#) for slot/card configuration rules.

The procedure for installing interface cards is as follows:

- 1) Check the exterior of the interface card for damage. Do not install if damaged.
- 2) Align each interface card to the guardrail of the universal slot and slide it in.

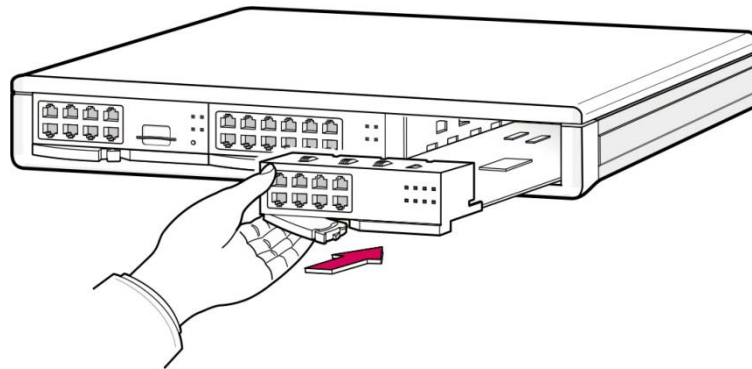

Figure 3.8 Installing Interface Cards

- 3) Press and lock the lever to fully insert.

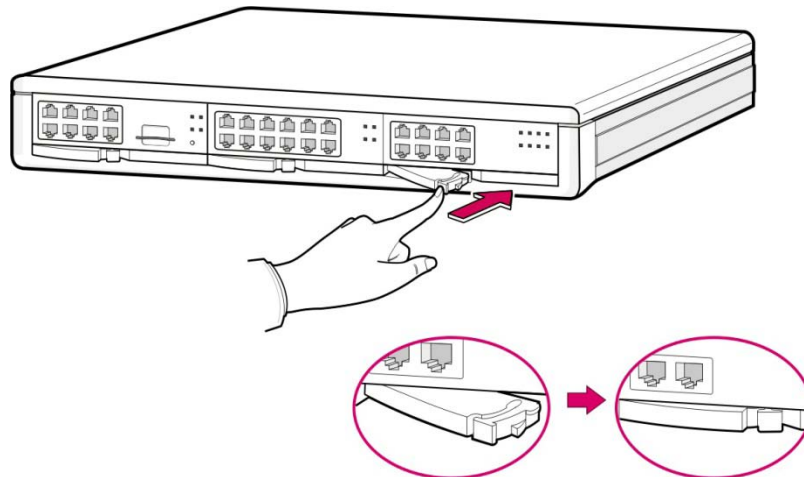



Figure 3.9 Inserting Interface Card into Slot 1 and 2

3.3.2 Replacing Cards

 **Removing Cables**
Replace a card after removing all cables connected to the card.

The procedure for replacing a card is as follows:

 **POWER TO THE CABINET MUST BE TURNED OFF BEFORE REMOVING CARDS.**
Failure to do so will damage the card, cabinet and/or corrupt the data moving along the data bus.

- 1) Turn off system power using the power switch in the back of the system.

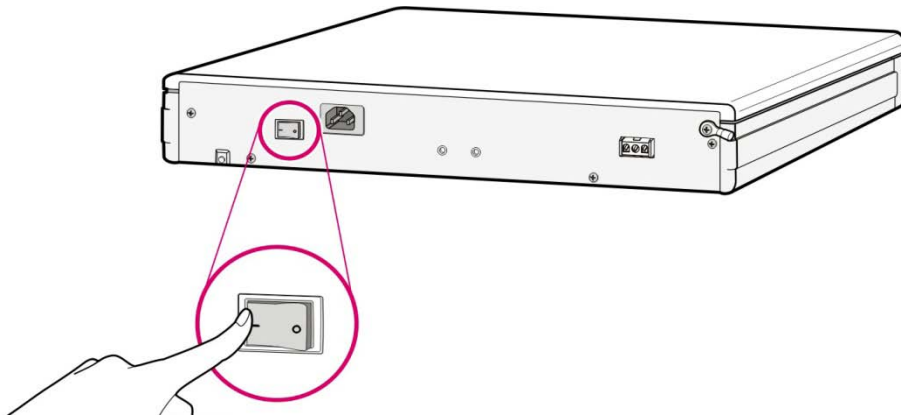

Figure 3.10 Turning the Cabinet Power Off

- 2) Extract the card by pulling the lever of the card carefully.

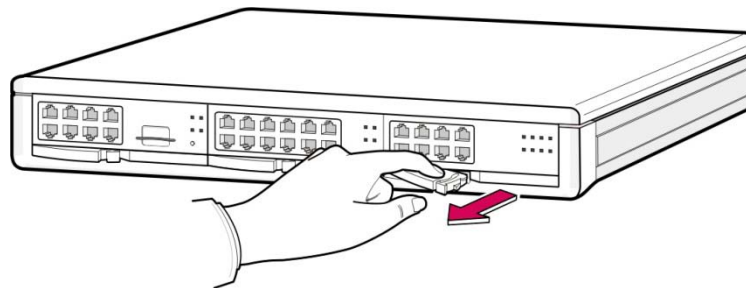

Figure 3.11 Removing a Card

- 3) Align the new card to the guardrail of the slot, and slide the new card into the slot. Then lock the lever in the front panel of the card to fully secure into the connector of the OfficeServ 7100 main card.

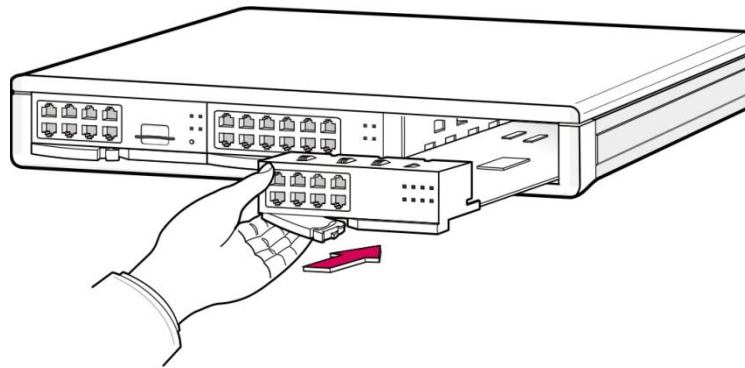

Figure 3.12 Replacing a Card

3.3.3 Installing UNI Cards and Daughtercard Modules

The UNI card is a universal base carrier card that can accommodate up to 3 optional daughtercards. The UNI card by itself serves no function. The UNI card can be installed in slot 1 and/or slot 2.

The UNI card has three positions to mount optional daughtercard modules. The mountable daughtercard modules are 4TRM, 4DLM and 4SLM. Up to three modules can be mounted regardless of the option module type. Any of these daughtercards can go into any of the 3 positions. The interface ports for each card are located on the front panel of the UNI card and are labeled accordingly.

Align the module to be mounted to the top connector (16-pin connector). After that, match the bottom connector (100-pin connector). Push the daughtercard in carefully until the card is fully seated into the connectors. Lock the supporter between the grooves and the top of each option card with screws.

Remove screws from UNI card before mounting the daughtercards then re-screw them in to lock down the daughtercards.

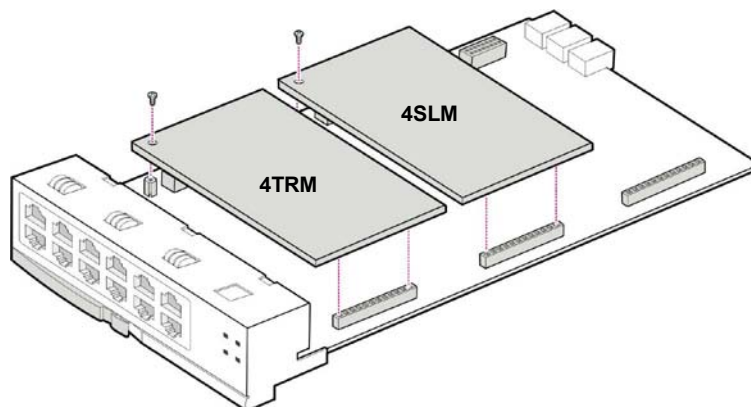

Figure 3.13 Installing the UNI Card

The front view of the UNI card is shown in the picture below.

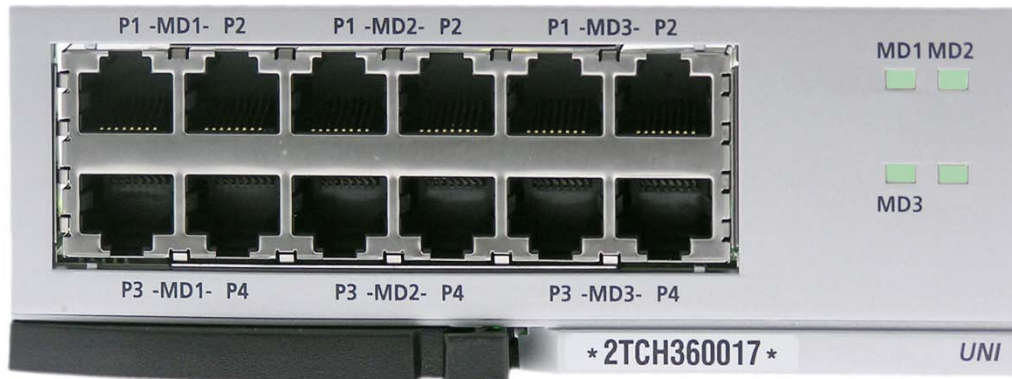

Figure 3.14 Front View of UNI Card

Table 3.4 UNI Card Ports and LEDs

Port, LED	Function Description
MD1 P1~P4 MD2 P1~P4 MD3 P1~P4	Ports that correspond with the daughtercard modules installed in the specific MD1, MD2 and MD3 connectors on the UNI card.
MD(1~3) LEDs	Shows the status of each daughterboard connector (MD1, MD2, and MD3) on the UNI card: - Off: No module mounted - On (Green): TRM mounted. - On (Red): DLM mounted. - On (Amber): SLM mounted.

3.4 DAUGHTERCARD MODULES

There are 5 different daughtercards available on the OfficeServ 7100:

- 1) **4SWM** (installed on MP10/MP10a only): 4 port PoE layer 2 LAN switch.
- 2) **Modem Daughtercard** (Installed on MP10/MP10a only): Provides modem communication for the OfficeServ 7100 system.
- 3) **4TRM** (installed on UNI card only): 4 port loop start trunk interface module.
- 4) **4DLM** (installed on UNI card or MP10/MP10a): 4 port digital phone interface module.
- 5) **4SLM** (installed on UNI card only): 4 port Single Line Analog telephone interface.

3.4.1 4SWM (4 Port PoE LAN Switch Daughtercard)

THIS DAUGHTERCARD CAN ONLY BE INSTALLED ON THE MP10/MP10a MAIN PROCESSOR BOARD ([refer to Section 3.2.3 "Installing the MP10/MP10a"](#)). This daughtercard CANNOT be installed on the UNI card. Only one 4SWM can be mounted per system. The 4SWM is a 4 port LAN Switch that

receives/transmits data from/to Intranet or Internet. The 4SWM provides four 10/100 Base-T Ethernet ports and performs the Layer 2 Switching function. These four ports support Power Over Ethernet (PoE) and are IEEE 802.3af compliant.

Power constraints must be taken into consideration when plugging ITP/SMT-i phones and WAP devices into the 4SWM PoE module.

- The OfficeServ 7100 power supply supports a maximum of 24 TDM phones or SEPU (Samsung equivalent power units). One power unit is equal to one (2 line TDM phone).
- A maximum of 4 ITP/SMT-i phones or 4 WAPs can be supported by the 4SWM PoE module.
- Each time an ITP/SMT-i phone is plugged into the 4SWM PoE port, the system capacity for TDM phones is decreased by 5.
- Each time a WAP is plugged into the 4SWM PoE port, the system capacity for TDM phones is decreased by 6.
- External power can be used to power the ITP/SMT-i phones and WAPs. If external power is used to supply power to the ITP/SMT-i phones or WAPs, no SEPU are used from the OS7100 4SWM PoE module.

POWER CONSUMPTION

OS7100 Samsung Equivalent Power Units (SEPU)		
Devices	KSU Power Units	Optional Power
iDCS Phones	1	N/A
DS 5000 Phones	1	N/A
ITP/SMT-i Phones	5	AC adapter or External PoE Switch
SMT 5000 WAPs	6	AC adapter or External PoE Switch

If you need more than 4 Ethernet ports, you can uplink this to an external Layer 2 data switch providing additional ports.

The main functions of the 4SWM board are as follows:

- Auto-sensing 10/100 Base-T and Full/Half duplex Ethernet switch
- Layer 2 LAN Switch function

The 4SWM is shown in the figure below:

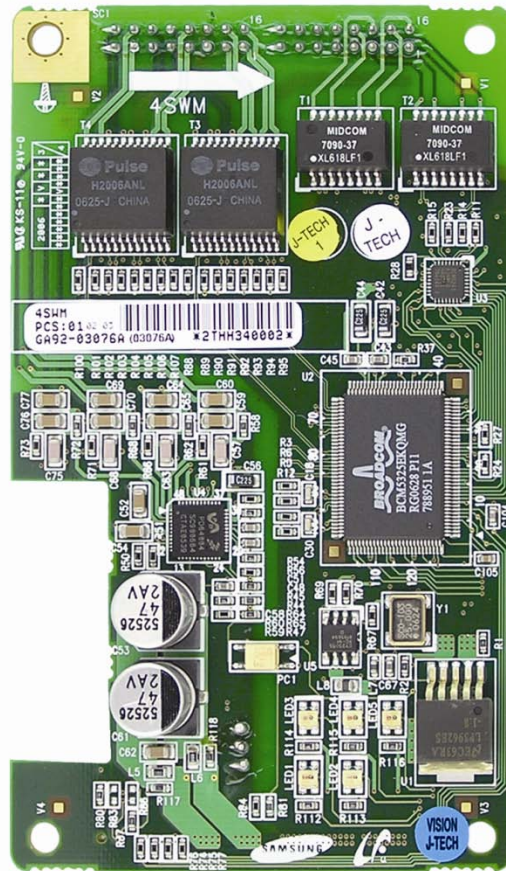

Figure 3.15 4SWM

3.4.2 Modem Daughtercard

The optional modem daughtercard is mounted to connector P7 of the MP10/MP10a card. This modem daughtercard allows remote dial up connection to the system for system administration and configuration. This is an alternative method for connecting to the system when a LAN/WAN connection is unavailable. The modem board has the following functions:

The modem board operates in OfficeServ 7100 via V.24 interface. In addition, the modem board supports the V.90 protocol. The OfficeServ 7100 controls the modem board via serial communication using standard AT commands.

[See Section 3.2.3 "Installing MP10/MP10a".](#)

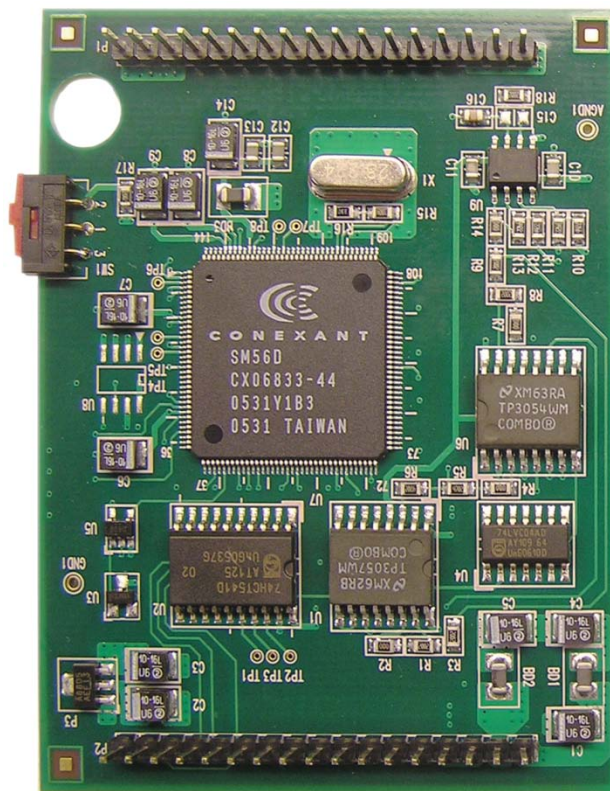

Figure 3.16 Modem Card

3.4.3 4TRM (4 Port Loop Start Trunk Interface Module)

This daughtercard provides 4 loop start trunk interface ports to connect to loop start analog trunk lines with Caller ID. This card provides analog trunks for your system. This daughtercard can only be installed on the UNI card. It can be installed in any of the 3 positions on the UNI card. This daughtercard cannot be installed on the MP10/MP10a. Add as many as needed.

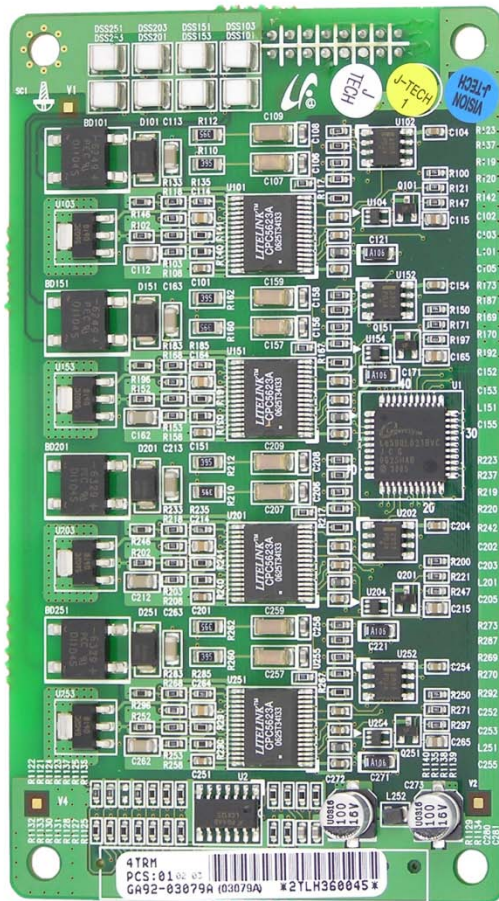

Figure 3.17 4TRM

3.4.4. 4DLM (4 Port Digital Phone Interface Module)

This daughtercard provides 4 ports for connecting Samsung Digital Key Sets. It can be installed on the MP10/MP10a card and any UNI card in any of the UNI card daughtercard positions. Add as many as needed.

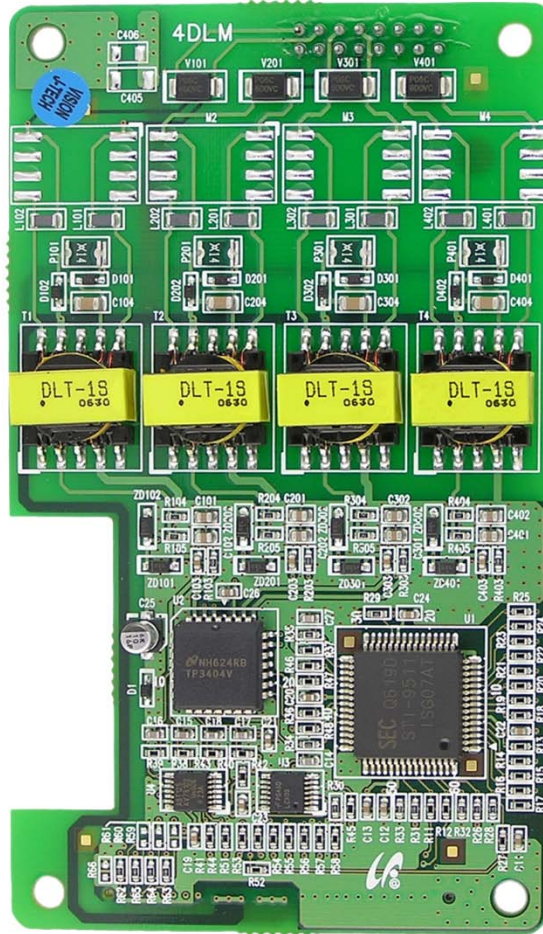

Figure 3.18 4DLM

3.4.5 4SLM (4 Port Single Line Telephone Interface Module)

This daughtercard provides 4 ports for connecting analog telephones. It also provides the message waiting lamp functionality for phones supporting this feature. It can ONLY be installed on the UNI card in any of the UNI card daughtercard positions. THIS DAUGHTERCARD CANNOT BE INSTALLED ON THE MP10/MP10a. Add as many as needed.

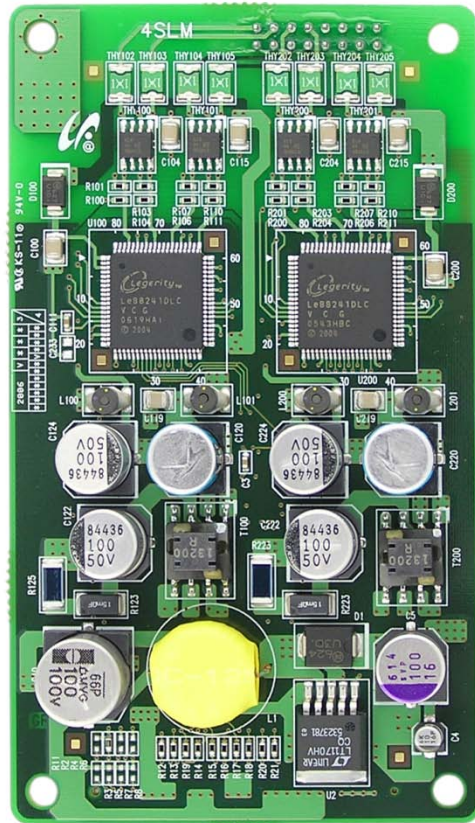

Figure 3.19 4SLM

3.5 OTHER INTERFACE CARDS

3.5.1 TEPRI and TEPRIa

The TEPRI(TEPRI/TEPRIa) card is a digital trunk interface that supports either T1 or ISDN PRI service. It also supports Q-Sig/PRI signalling required for networking multiple systems.

NOTE: The OfficeServ 7100 only supports PRI and does not support T1 service even though the TEPRI and TEPRIa cards support both.

The TEPRI/TEPRIa card can be installed in slots 1 and/or 2. The first four LEDs on the front of the card provide the status of the service (Sync, AIS, Loss and Layer 2 Active states). The second four LEDs on the front of the card display the type of service. The first TEPRI/TEPRIa card installed in the OfficeServ 7100 is the primary source of external clocking. The second TEPRI/TEPRIa installed is the secondary source of external clocking. Default clock selection is left to right in the cabinet. The clock priority can be changed by using MMC 826. Regardless of position, a CO PRI circuit should always be given clocking priority over T1 circuits. There are two RJ45 modular jacks on the face of the card. The settings for T1 or PRI service are selected by a bank of dip switches as defined below. The PRI supports NI1, NI2, AT&T No. 5 ESS, and DMS 100 offices. A maximum of 2 TEPRI/TEPRIa cards can be provided per system. **NOTE: Do not insert this card with system power ON.**

TEPRI/TEPRIa Card Dip Switch

Switch No.	ON	OFF
1	T1	E1
2	PRI	T1
3	NFAS (24B)	NFAS (23B + D)
4	NETWORK*	USER
5	AFT	NORMAL
6	**	**
7	**	**
8	**	**

*If this TEPRI/TEPRIa card is to be the master of a pair of TEPRI/TEPRIa cards that are used to connect two systems together via PRI networking then this DIP switch, DIP switch 4 must be set to ON.

**Do not change the settings of DIP switches 3, 5, 6, 7, and 8. Switches 3, 5, 6, and 7 must remain OFF and 8 must be ON.

See the S1 switch and jumpers of the TEPRI/TEPRIa card as shown below.

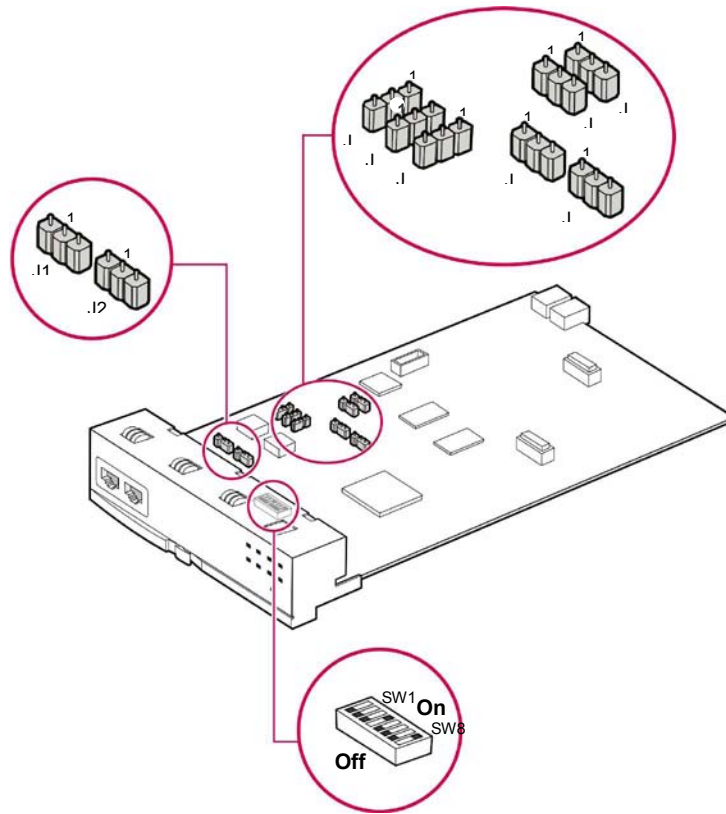

Figure 3.20 Setting Switches on the TEPRI/TEPRIa

JUMPER SETTING

The TEPRI/TEPRIa card comes from the factory with the following jumper settings. **These settings should NOT be changed.**

- J1 & J2: Pins 2 & 3 connected
- J3: Pins 2 & 3 connected
- J4~J9: Pins 1 & 2 connected
- Pin 1 is labeled on the card for each jumper

FRONT VIEW OF TEPRI/TEPRIa

The front view of the TEPRI/TEPRIa card is shown in the picture below.



Figure 3.21 Front View of the TEPRI/TEPRIa

Front panel components of the TEPRI/TEPRIa:

Table 3.5 Ports and LEDs of the TEPRI/TEPRIa

Ports & LEDs	Function Description
PRI	Ports that connect the PRI cable. (T1 is not supported)
SIO	Serial port (for Samsung Use ONLY)
RST	Button for resetting the TEPRI/TEPRIa card.
SYNC LED	Clock synchronization. - On: Indicates loss of framing (Error Condition). - Off: Clocks are synchronized when they inter-work with the counterpart station (Normal).
LOS LED	This LED indicates loss of signal. - On: Signals have been lost; no PCM clocking is being received. - Off: Signals being received (Normal).
AIS LED	This LED indicates whether the PRI remote alarm has been generated. - On: The remote alarm has been generated. All ones are being received (Error). - Off: The remote alarm has not been generated (Normal).
L2 LED	This LED indicates the operation status of Layer 2. - On: The PRI Layer 2 is operating properly. PRI message is being received. - Off: The PRI Layer 2 is operating abnormally.
IPC LED	This LED indicates that this card is inter-working with the higher-level module. - On: The card is inter-working with the MP10/MP10a. - Off: The card is not inter-working with the MP10/MP10a.

Ports & LEDs	Function Description
CLK LED	This LED indicates whether this card is a master or slave. - On: The card has received the synchronization clock from the counterpart station. - Off: Using synchronous clock for internal clock.
TP1 LED	This LED indicates whether the T1 is established. - This LED turns on once the T1 is established. (T1 is not supported)
TP2 LED	This LED indicates whether the PRI is connected. - This LED turns on once the PRI is connected. (T1 is not supported)

[Refer to Section 6.2.2 for Port Pinout and Wiring.](#)

3.5.2 8TRK

The 8TRK card provides 8 ports for analog trunk lines with Caller ID capabilities. This card can go into any universal slot (1~2). Add as many as needed.

FRONT VIEW OF 8TRK

The front view of the 8TRK card is shown in the picture below.

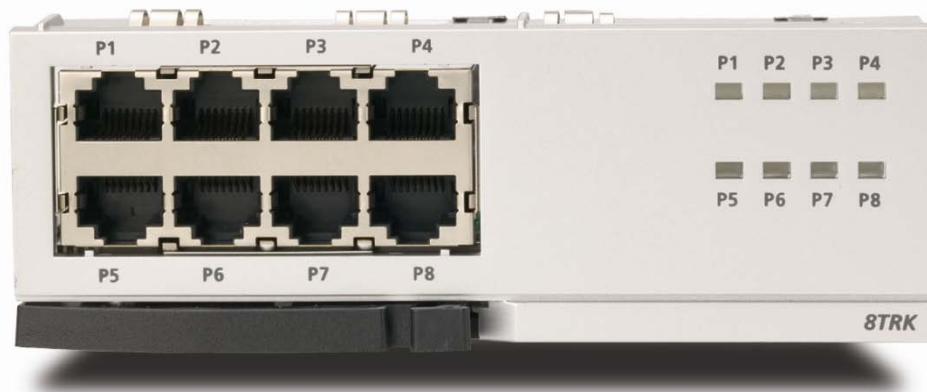

Figure 3.22 Front View of the 8TRK

The components on the front panel of the 8TRK have the functions below:

Table 3.6 Ports and LEDs of the 8TRK

Ports & LEDs	Function Description
P1~P8	Trunk ports.
P1~P8 LED (8TRK ONLY)	These LEDs indicate the status of the ports. - Off: The trunk line is not being used. - On: The trunk line is being used.

[Refer to Section 6.2.1 for Port Pinout and Wiring.](#)

3.5.3 8TRK2

There are no LEDs on this board compared to the 8TRK card.

FRONT VIEW OF 8TRK2

The front view of the 8TRK2 board is shown in the picture below.

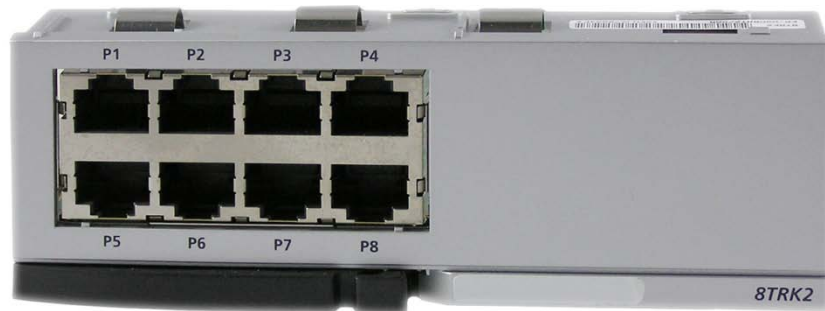

Figure 3.23 Front View of the 8TRK2

3.5.4 16TRK

This card contains sixteen loop start C.O. line interface circuits with C.O. disconnect detection. It also contains the circuitry needed for Caller ID. It can be inserted in any universal slot in either cabinet.

FRONT VIEW OF 16TRK

The front view of the 16TRK board is shown in the picture below.

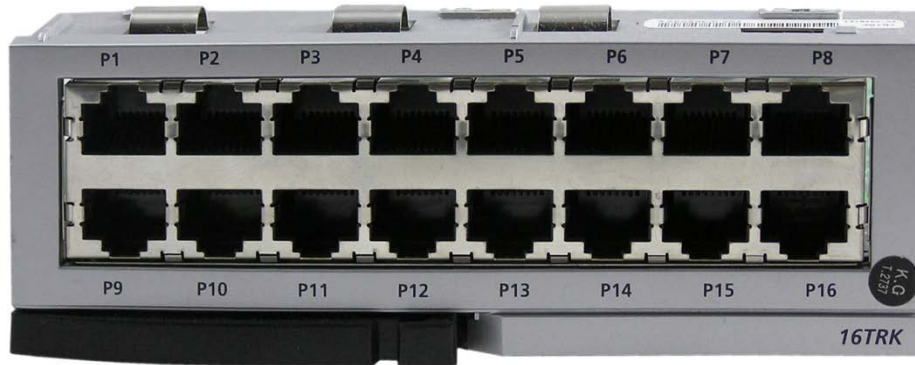

Figure 3.24 Front View of the 16TRK

The components on the front panel of the 16TRK have the functions below:

Table 3.7 Ports and LEDs of the 16TRK

Ports & LEDs	Function Description
P1~P16	Trunk ports.
LED	There are no LEDs on this card.

3.5.5 16DLI2

This card provides 16 ports for connecting Samsung Digital Keysets. Each port provides 1B+D. This means only one station/one voice channel per port. This card can go into slots 1 and/or 2. Add as many as needed.

FRONT VIEW OF 16DLI2

The front view of the 16DLI2 card is shown in the picture below.

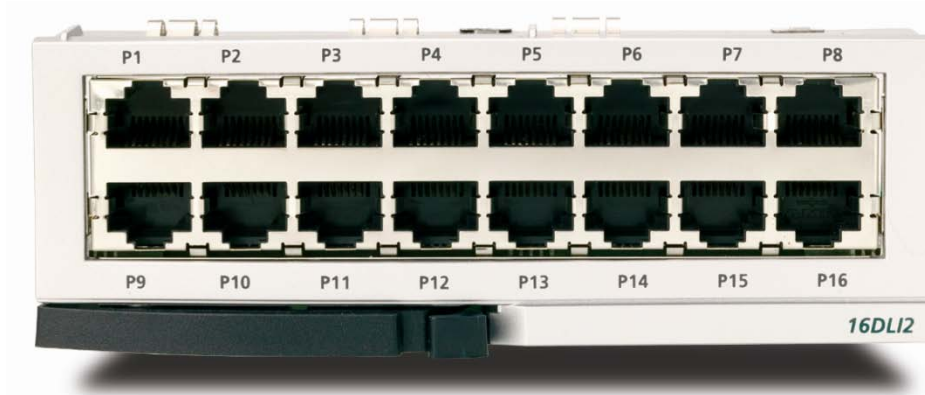

Figure 3.25 Front View of the 16DLI2

16DLI2 front panel components:

Table 3.8 Ports of the 16DLI2

Ports	Function Description
P1~P16	Samsung Digital Telephone Extension Port

[Refer to Section 7.1.3 \(Connecting a Digital Phone\) for port Pinout and Wiring.](#)

3.5.6 8DLI

This card provides 8 ports for connecting Samsung Digital Key sets. This card can go into slots 1 and/or 2. Add as many as needed.

SPECIFICATIONS

The specifications of the 8DLI card are as follows:

- 8 station ports

NOTE: KDB-D or KDB-S adapters are not supported on the OfficeServ 7100 system.

FRONT VIEW OF 8DLI

The front view of the 8DLI card is shown in the picture below.

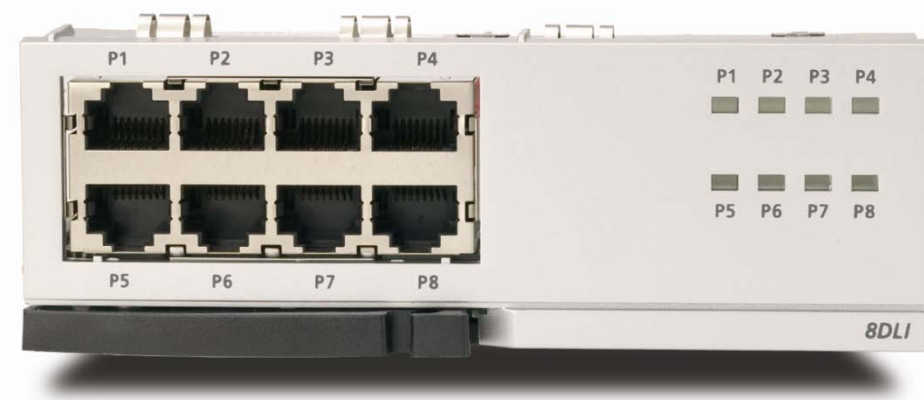

Figure 3.26 Front View of the 8DLI

Front panel components of the 8DLI card have the functions below:

Table 3.9 Ports and LEDs of the 8DLI

Ports & LEDs	Function Description
P1~P8	Station ports of Samsung Digital Phones.
P1~P8 LED	These LEDs indicate the status of the ports. -Off: The station is not being used. -On: The station is being used.

[Refer to Section 7.1.3 for Port Pinout and Wiring.](#)

3.5.7 8COMBO/8COMBO2

The 8COMBO/8COMBO2 cards provide 8 ports for connecting analog stations and 8 ports for connecting Samsung Digital Key sets. This card can go into slots 1 and/or 2. Add as many as needed.

FRONT VIEW OF 8COMBO/8COMBO2

The front view of the cards is shown in the pictures below.

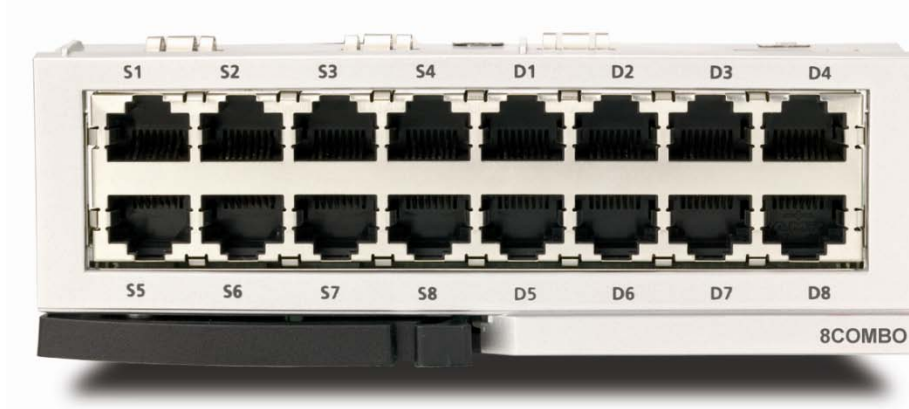

Figure 3.27 Front View of the 8COMBO

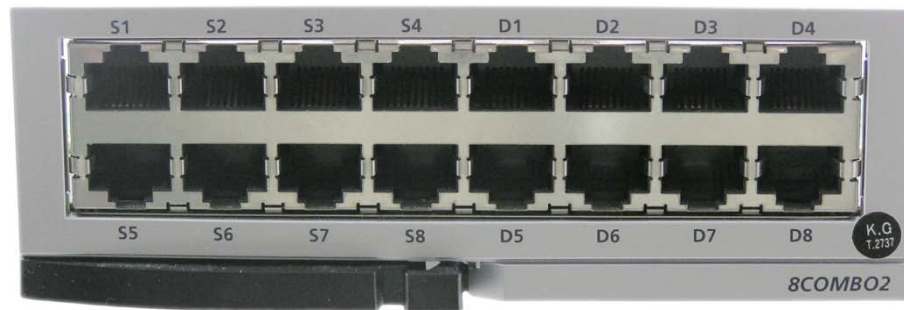

Figure 3.28 Front View of the 8COMBO2

- Ports S1~S8 are for analog stations only.
- Ports D1~D8 are for Samsung Digital Stations only.

[See Sections 7.1.2 and 7.1.3 for Port Pinout and Wiring.](#)

3.5.8 16MWSLI

This card provides 16 ports for connecting analog stations. It can go into slots 1 and/or 2. Add as many as needed. This card automatically detects DTMF or dial pulse signals from the SLT. This card has no DTMF receiver. It will share the system resources.

FRONT VIEW OF 16MWSLI

The front view of the 16MWSLI card is shown in the picture below.

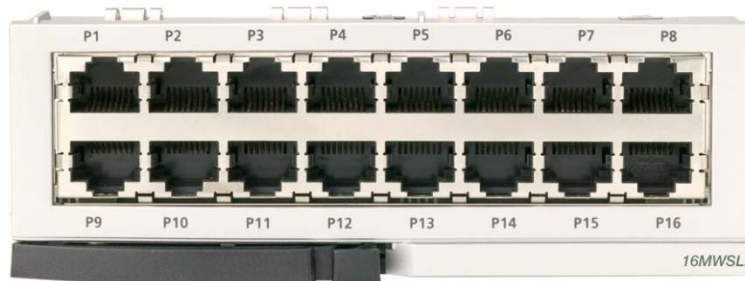

Figure 3.29 Front View of the 16MWSLI

Front panel components of the 16MWSLI:

Table 3.10 16MWSLI Ports

Ports & LEDs	Function Description
P1~P16	Analog Extension Ports

- The 16MWSLI supports Message Waiting Lamp functionality for analog stations that have this capability.
- Port 1 (Pins 7 & 8) supports Power Failure Transfer function ([Refer to Section 3.4](#)).
- [See Section 7.1.2 for Port Pinout and Wiring](#).
- Do not connect devices with a total REN greater than 5.0 to this card.

3.5.9 8SLI/8SL2

The 8SLI/8SLI2 cards provide 8 ports for connecting analog stations. It can go into slots 1 and/or 2. Add as many as needed. This card automatically detects DTMF or dial pulse signals from SLT. This card does not have any DTMF receivers; it uses system resources.

FRONT VIEW OF 8SLI/8SLI2

The front view of the 8SLI/8SLI2 cards is shown in the figure below:

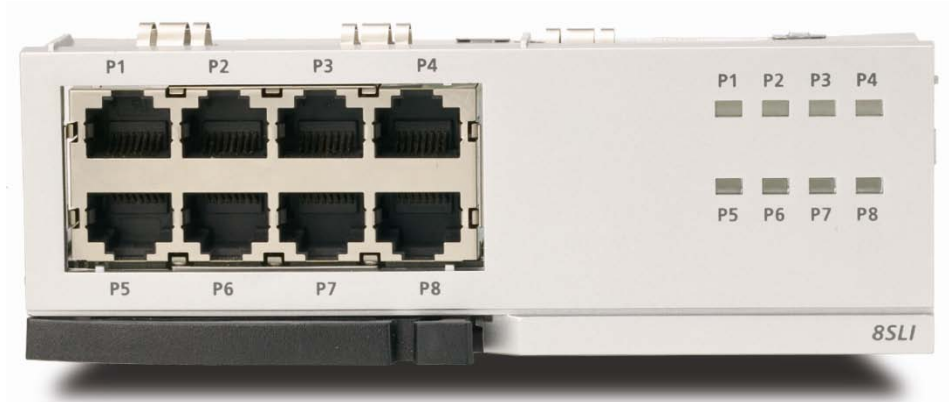

Figure 3.30 Front View of the 8SLI Card



Figure 3.31 Front View of the 8SLI2 Card

Front panel components of the 8SLI/8SLI2:

Table 3.11 Ports and LEDs of the 8SLI/8SLI2

Ports & LEDs	Function Description
P1~P8	Station ports for analog phones.
P1~P8 LED	These LEDs indicate the operation status of the ports. - Off: The station is not active on a call. - On: The station is active on a call.

- Port 1 (Pins 1 & 2) supports Power Failure Transfer function ([Refer to Section 3.4](#)).
- [See Section 7.1.2 for port Pinout/Wiring](#).
- Do not connect devices with a total REN greater than 5.0 to this card.

3.5.10 MGI16

The MGI16 is a 16-channel Media Gateway Card. The MGI16 card provides a variety of Voice over IP (VoIP) services for the OfficeServ 7100. This card is used for ITP/SMT-i phones, IP networking, IP trunking or any application that require VoIP functionality.

NOTE: The MP10/MP10a processor cards have 8 MGI channels built-in. However, these channels have to be activated with the appropriate license key entered in MMC 841. Refer to the OfficeServ 7100 Programming Manual for details. The MGI16 does NOT require any licenses to operate.

SPECIFICATIONS

- The MGI16 does not require any daughtercards. It offers 16 VoIP channels (respectively) on board.
- The MGI16 can be installed in slot 1 or 2.



Figure 3.32 Front View of the MGI16 Card

Table 3.12 MGI16 Front Panel Components

Ports & LEDs	Function Description
LAN	Port that connects the Ethernet.
SIO	Serial Port (for Samsung Use ONLY)
RST	Button for resetting the MGI.
PWR LED	This LED indicates the power supply status. - Off: Power is not being supplied. - On: Power is being supplied properly.
RUN LED	This LED indicates MP10/MP10a status. - Off: Power is not being supplied. - On: Booting. - Blink: The RAM program is operating.
LAN Tx LED	This LED indicates the transmit status of the LAN port. - Off: Data is not being transmitted. - On or blink: Data is being transmitted.
LAN Rx LED	This LED indicates the receive status of the LAN port. - Off: Data is not being received. - On or blink: Data is being received.
SVC LED	This LED indicates if the service is being offered. - This LED blinks when program is being modified or configuration is being loaded.
DSP LED	This LED indicates if the VoIP DSP is operating. - This LED blinks when the VoIP channels are engaged.
RTPT LED	This LED indicates if the voice packets are being forwarded. - This LED turns on when the voice packets are forwarded.
RTPR LED	This LED indicates if the voice packets are being received. - This LED turns on when the voice packets are received.

3.5.11 OAS (OPTIONAL APPLICATION SERVICES)

The OAS card is a lower-cost alternative to the MGI-16 card, and provides all the same functionality and capacities as an MGI-16 in OfficeServ 7100 systems. The MGI channels can be configured in MMC 831 and MMC 835.

SPECIFICATIONS

- The OAS card can be installed in slots 1 or 2 if the OfficeServ 7100.
- Only one (1) OAS card can be installed in the OfficeServ 7100.
- The MOBEX DSP and MPS channel features of the OAS card are not available on the OfficeServ 7100 as these features are embedded on the MP10/MP10a processor card.



Figure 3.33 Front View of the OAS Card

Table 3.13 OAS Front Panel Components

Ports & LEDs	Function Description
LAN	Port that connects the Ethernet.
SIO	Serial Port (for Samsung Use ONLY)
RST	Button for resetting the OAS.
PWR LED	This LED indicates the power supply status. - Off: Power is not being supplied. - On: Power is being supplied properly.
RUN LED	This LED indicates MP40 status. - Off: Power is not being supplied. - On: Booting. - Blink: The RAM program is operating.
LAN Tx LED	This LED indicates the transmit status of the LAN port. - Off: Data is not being transmitted. - On or blink: Data is being transmitted.
LAN Rx LED	This LED indicates the receive status of the LAN port. - Off: Data is not being received. - On or blink: Data is being received.
SVC1 LED	This LED indicates if the MOBEX DSP service is being offered. - This LED blinks when program is being modified or configuration is being loaded.
SVC2 LED	This LED indicates if the LAN connection is alive. - This LED blinks when program is being modified or configuration is being loaded.
SVC3 LED	This LED indicates if the MPS channel service is being offered. - This LED blinks when program is being modified or configuration is being loaded.

Ports & LEDs	Function Description
SVC4 LED	This LED indicates if the MGI channel service is being offered. - This LED blinks when program is being modified or configuration is being loaded.

HARDWARE CAPACITIES

Interface Card	Location	Maximum per System
UNI card	Slots 1 & 2	2
4SWM	MP10/MP10a only	1
4DLM	UNI card & MP10/MP10a	6
4SLM	UNI card	6
4TRM	UNI card	5
8TRK	Slots 1 & 2	2
8COMBO/8COMBO2	Slots 1 & 2	1
8SLI/8SLI2	Slots 1 & 2	2
8DLI	Slots 1 & 2	2
16DLI2	Slots 1 & 2	1
16MWSLI	Slots 1 & 2	1
TEPRIa	Slots 1 & 2	1
MGI16	Slots 1 & 2	1
OAS	Slots 1 & 2	1

3.6 CONNECTING POWER FAIL TRANSFER

The OfficeServ 7100 offers a Power Fail Transfer feature for analog single line telephones that are connected to port 1 (pins 1 & 2) on the 8SLI or port 1 (pins 7 & 8) on the 16MWSLI cards.

In case the OfficeServ 7100 loses power from its AC source, and no battery backup is available, this feature is automatically activated. The SLT connected to port 1 of the SLI will get C.O. dial tone (direct C.O. line access) activated by an internal relay. For this feature to work, the SLI ports must be wired as shown in [Figure 3.29](#) Pin 4 (TIP) and Pin 5 (RING) from a port on the 8TRK/8TRK2 card (or a port of the 4TRM module) must be connected to Pin 1 (TIP) and Pin 2 (RING) on port 1 (pins 1 & 2) of an 8SLI card or port 1 (pins 7 & 8) of 16MWSLI card.

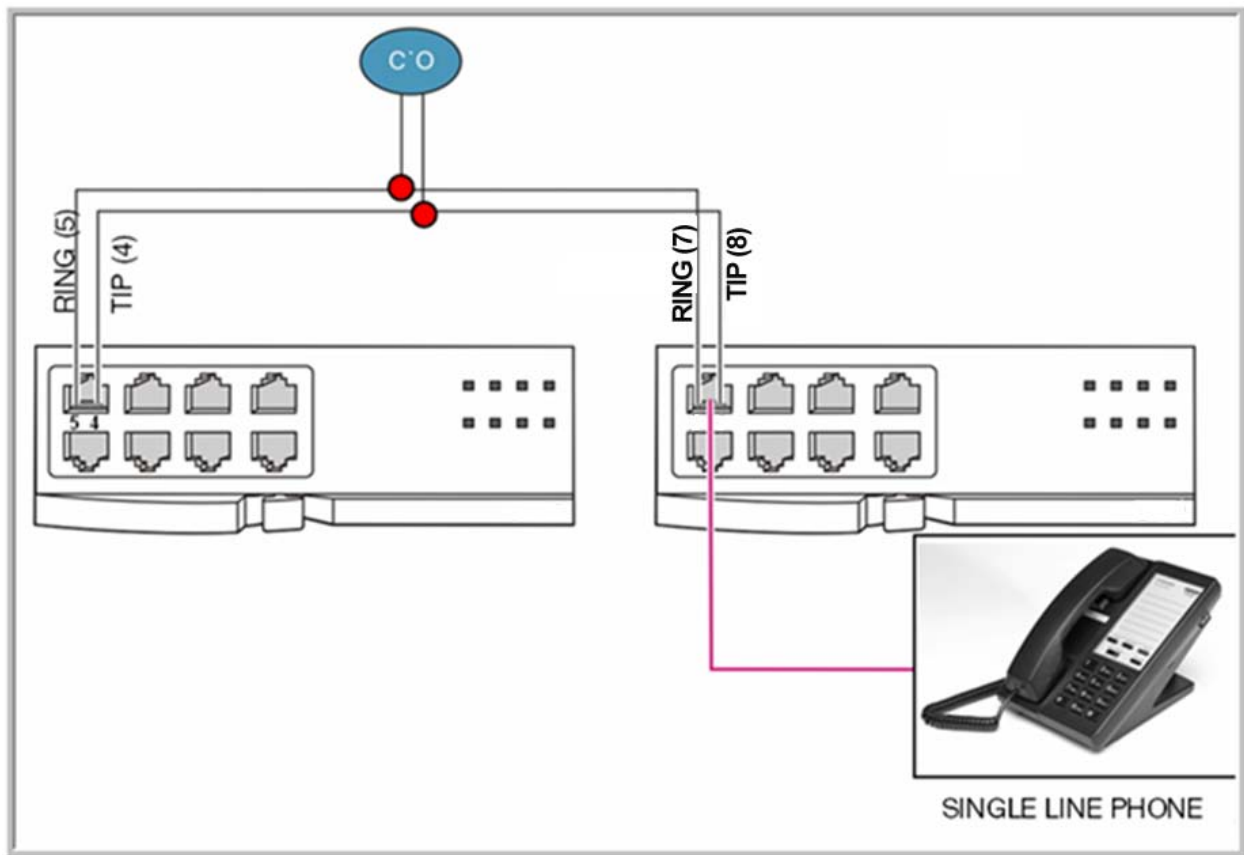

Figure 3.34 Example of Power Fail Transfer Connection to 8SLI

PART 4. CONNECTING EXTERNAL BATTERIES

This section describes how to connect external batteries to the OfficeServ 7100 system.

4.1 CONNECTING EXTERNAL BATTERIES

CAUTIONS FOR CONNECTING EXTERNAL BATTERIES

External batteries are required to maintain stable operation of the OfficeServ 7100 system in case a power failure occurs. The capacity for this battery should be rated at DC 48V. A fuse (125VAC, 5Amp) should be positioned between the output terminal of the battery and the cabinet.



Cautions for connecting external batteries

Do not connect external AC power to the system before completing the connection between batteries and the system. If so, it may cause electric shock. Check the specified polarity (+ or -) to connect external batteries.



To reduce risk of fire and injury, use only a sealed nickel cadmium or lead-acid battery supply capable of handling a charge current of 0.25A, a charge voltage of -54V DC, and a discharge rate of 26Ah.

Observe the following precautions when installing batteries:

- Make sure the batteries you install conform to local building, fire and safety codes. Some battery types emit hydrogen gas during the charging state and may require venting to fresh air.
- Do not place batteries directly on a concrete floor. This causes them to discharge very quickly.
- Follow the battery manufacturer's recommended installation and maintenance procedures.

PROCEDURE FOR CONNECTING EXTERNAL BATTERY

The procedure for using a battery cable to connect an external battery to the OfficeServ 7100 system is as follows:

- 1) Use the battery cable that was provided with the OfficeServ 7100 system. The battery cable consists of a white wire and a black wire.
- 2) Connect the white wire of the battery cable to the (+) terminal, and the black wire to the (-) terminal of the battery. Connect the other end of the battery cable to the external battery socket on the rear panel of the OfficeServ 7100 cabinet.

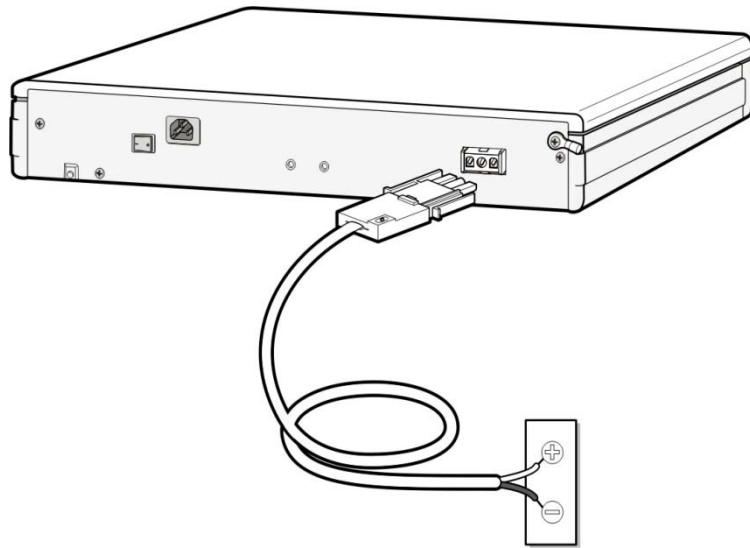

Figure 4.1 Connecting an External Battery

PART 5. CONNECTING POWER

This section describes how to connect power to the OfficeServ 7100 system.

5.1 BEFORE CONNECTING POWER

When input power is normally supplied, the AC power is supplied to the Power Supply Unit (PSU), which charges the external battery. If the input power is interrupted, the system can be operated using the charged power of the external battery.

- System supports only 110V AC power connections.
- A single AC outlet should be used solely for the system's AC power. Sharing the AC power with other devices can cause noise or a voltage drop, resulting in a system malfunction or fire.
- Use a stable power source that can always supply AC power since instantaneous power failures can cause malfunctions or battery failures.
- [System should be grounded as described in Part 1.2 and Part 2.5.](#)

5.2 PROCEDURE FOR CONNECTING POWER

Use the power cable provided with the OfficeServ 7100 system to connect the input power terminal on the back panel to a grounded outlet.

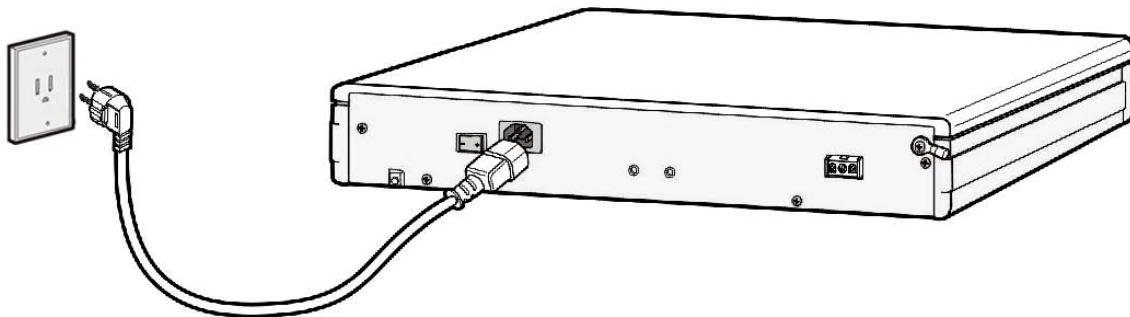

Figure 5.1 Connecting Power

PART 6. CONNECTING C.O. LINES

This section describes how to connect C.O. lines to the OfficeServ 7100 system after installation.

6.1 SAFETY PRECAUTIONS

To reduce the risk of personal injury, follow these precautions before connecting TELCO circuits:

- Wires with AWG #24 or AWG #26 width should be used as subscriber lines.
- Never touch non-insulated telephone wires or terminals unless the telephone line has been disconnected at the Network Interface.
- When wiring cables in high-humidity areas, remove moisture before wiring.
- Never install telephone jackets in a wet location unless the jack is specifically designed for wet locations.
- Wires should be handled carefully to prevent any changes or damages.
- Subscriber lines should be kept indoors if possible.
- High voltage power lines should not be wired near a subscriber line.
- Never install telephone wiring during a lightening storm.

Leak resistance for C.O. lines connected to the OfficeServ 7100 system is as follows:

Table 6.1 OfficeServ 7100 Line Conditions

Line Condition	Leak Resistance
Leak Resistance Between Lines	20 k Ω or higher
Leak Resistance Between Grounds	20 k Ω or higher

6.2 CONNECTING C.O. LINES

6.2.1 Connecting Analog Loop Start Lines

Use a twisted pair (AWG #24 (or AWG #26) wire or cord to connect an analog loop start C.O. line to pins 4 & 5 of the RJ45 jack on the 8TRK/8TRK2/16TRK or 4TRM installed in the OfficeServ 7100 system.

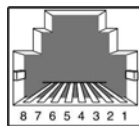

P1-P8 Port
(RJ-45)

Pin No.	1	2	3	4	5	6	7	8
Function	-	-	-	C.O.TIP	C.O. RING	-	-	-

Figure 6.1 TIP and RING connections to Analog Trunk Cards

6.2.2 Connecting ISDN-PRI

Connect an ISDN-PRI C.O. circuit to the RJ-45 port on the OfficeServ TEPRI/TEPRIa card.

Using a standard, straight through eight conductor data cable or straight through eight conductor line cord to connect the customer provided Channel Service Unit (CSU) to the TEPRI/TEPRIa card as shown in [Figure 6.2](#).

NOTES:

1. It may be necessary to cut off the CSU end of the cable and attach a different connector to match that of the CSU. If possible, this connection should be soldered because good connections are critical.
2. It is recommended that the CSU be connected to the network interface with a cable supplied by the CSU manufacturer. If this is not possible or practical, a custom cable has to be made up. This cable should be made from 22 gauge two pair cable with each pair individually shielded. It is recommended that the connections on this cable be soldered wherever possible to ensure good connections. The shielding of the cable should be connected to ground at the CSU end only to prevent a ground loop.
3. T1/E1 is not supported on the OfficeServ 7100 system.

PARAMETERS supported on OfficeServ all TEPRI cards installed in the 7100

FRAMING	T1 Circuit	PRI Circuit
Super Frame (D4 56K Frame)	Not Supported	Not Supported
Extended Super Frame (ESF 64K Frame)	Not Supported	Yes
CODING	T1 Circuit	PRI Circuit
AMI - 56K Coding	Not Supported	Not Supported
B8ZS - ESF 64k Coding	Not Supported	Yes
NFAS (Non Facility Associated Signaling)	Not Supported	Not Supported

Use MMC 808 to set the parameters to match the Telco PRI circuit.

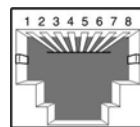

PRI Port
(RJ-45)

Pin No.	1	2	3	4	5	6	7	8
PRI Function	Rx+	Rx-	-	Tx+	Tx-	-	-	-

Figure 6.2 RJ-45 Port of TEPRI/TEPRIa

6.2.3 Connecting a SIP Trunk

There is no physical SIP trunk card required to use the SIP trunking service. However, in order to use the SIP trunking service, the OfficeServ system must be IP-enabled. That means that the OfficeServ system must have an MGI card with the latest MP software and have high speed Internet connection.

Please refer to the "OfficeServ Series SIP Trunking Quick Reference Document" for configuration.

PART 7. CONNECTING STATIONS AND ADDITIONAL EQUIPMENT

This section describes how to connect various stations and additional equipment, such as analog/digital phones, door phones and door locks, to the OfficeServ 7100 system.

7.1 CONNECTING STATIONS

7.1.1 Safety Precautions

To reduce the risk of personal injury, follow these precautions before connecting telephone circuits:

- Never install telephone wiring during a lightening storm.
- Never install telephone jacks in a wet location unless the jack is specifically designed for wet locations.
- Do not connect stations in a humid area.
- Never touch non-insulated telephone wires or terminals unless the telephone line has been disconnected at the network interface.
- Connect stations using #24 AWG or #26 AWG cables.

The maximum distance between stations and the OfficeServ 7100 are as follows:

Table 7.1 Distance Between Stations and the System

Station	Distance
Digital phone	Maximum 400m/1312ft (for AWG #24)
Analog phone	Maximum 1km/3280ft (for AWG #24)
Door phone	Maximum 400m/1312ft (for AWG #24)
AOM (Add-On Module)	Maximum 400m/1312ft (for AWG #24)

7.1.2 Connecting an Analog Phone

Connect an analog phone to the 8SLI, 16MWSLI, 8COMBO/8COMBO2 (analog ports only) cards or the 4SLM (mounted on UNI card) installed in the OfficeServ 7100 system.

CONNECTING TO THE 8SLI/8SLI2

Connect an analog phone to the 8SLI/8SLI2 card by using a twisted pair of AWG #24 or AWG #26 wire.



P1 Port

Pin No.	1	2	3	4	5	6	7	8
Function	PFT TIP	PFT RING	-	SLI 1 TIP	SLI 1 RING	-	-	-

P2-P8 Ports

Pin No.	1	2	3	4	5	6	7	8
Function	-	-	-	SLI TIP	SLI RING	-	-	-

Figure 7.1 RJ-45 Port of the 8SLI

CONNECTING TO THE 16MWSLI

Connect an analog phone to the 16MWSLI card by using a twisted pair of AWG #24 or AWG #26 wires.



P1 Port

Pin No.	1	2	3	4	5	6	7	8
Function			-	SLI 1 TIP	SLI 1 RING	-	PFT TIP	PFT RING

P2-P16 Ports

Pin No.	1	2	3	4	5	6	7	8
Function	-	-	-	SLI TIP	SLI RING	-	-	-

Figure 7.2 RJ-45 Port of the 16MWSLI

CONNECTING TO THE 8COMBO/8COMBO2

Connect an analog phone to the 8COMBO/8COMBO2 card by using a twisted pair of AWG #24 or AWG #26 wires.

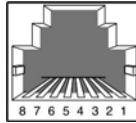

S1-S8 Port
(RJ-45)

S1-S8 Ports

Pin No.	1	2	3	4	5	6	7	8
Function	-	-	-	SLI TIP	SLI RING	-	-	-

Figure 7.3 RJ-45 Port of the 8COMBO/8COMBO2 (For Analog Phone)

CONNECTING TO THE 4SLM PORT ON A UNI CARD

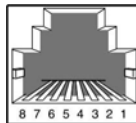

Pin No.	1	2	3	4	5	6	7	8
Function	-	-	-	SLI TIP	SLI RING	-	-	-

Figure 7.4 RJ-45 4SLM Port on the UNI Card

7.1.3 Connecting a Digital Phone

Connect a digital phone to 8DLI, 16DLI2, 8COMBO/8COMBO2 (digital ports only) or 4DLM (mounted on a UNI Card) card.

CONNECTING TO 4DLM MOUNTED ON A UNI CARD

Connect a digital phone to the 4DLM port by using a twisted pair AWG #24 or AWG #26 wires.

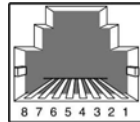

P1~P4 Port
(RJ-45)

P1-P4 Ports

Pin No.	1	2	3	4	5	6	7	8
Function	-	-	-	DLI TIP	DLI RING	-	-	-

Figure 7.5 RJ-45 4DLM Port on the UNI Card

CONNECTING TO 8DLI CARD

Connect a digital phone to the 8DLI card by using a twisted pair AWG #24 or AWG #26 wires.

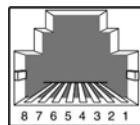

P1~P8 Port
(RJ-45)

P1-P8 Ports

Pin No.	1	2	3	4	5	6	7	8
Function	-	-	-	DLI TIP	DLI RING	-	-	-

Figure 7.6 RJ-45 Port of the 8DLI (For Digital Phone)

CONNECTING TO 16DLI2

Connect a digital phone to the 16DLI2 card by using a twisted pair of AWG #24 or AWG #26 wires.

P1-P16 Ports

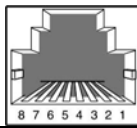

P1-P16
Port
(RJ-45)

Pin No.	1	2	3	4	5	6	7	8
Function	-	-	-	DLI TIP	DLI RING	-	-	-

Figure 7.7 RJ-45 Port of the 16DLI2 (For Digital Phone)

CONNECTING TO 8COMBO/8COMBO2

Connect a digital phone to the 8COMBO/8COMBO2 card by using a twisted pair of AWG #24 or AWG #26 wires.

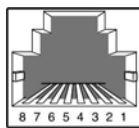

D1~D8
Port
(RJ-45)

D1-D8 Ports

Pin No.	1	2	3	4	5	6	7	8
Function	-	-	-	DLI TIP	DLI RING	-	-	-

Figure 7.8 RJ-45 Port of the 8COMBO/8COMBO2 (For Digital Phone)

7.1.4 Connecting an IP Phone

[Refer to the ITP-5121D Keyset User Guide, ITP-5112L Keyset User Guide, ITP-5107S Keyset User Guide, SMT-i3105 User Guide, SMT-i5210 User Guide, SMT-i5220 User Guide, SMT-i5230 User Guide, and SMT-i5243 User Guide for information on connecting IP keysets.](#)

Note: If using the on-board MGI resources of the MP10/MP10a, you must activate the MGI license key in system programming to enable the specific number of MGI channels.

7.1.5 Connecting Cards to LAN

4SWM (P1~P4), MGI-16, OAS, and MP-10 (LAN port) cards can be connected to a LAN by using an Ethernet cable.



Pin No.	1	2	3	4	5	6	7	8
Function	Tx+	Tx-	Rx+	-	-	Rx-	-	-

Figure 7.9 LAN Connections

- 4SWM Ports (P1~P4)
- MGI16/OAS, LAN Port
- MP10/MP10a LAN Port

7.1.6 Connecting a Door Phone and a Door Lock

Connect a door phone and a door lock to the OfficeServ 7100 system using a Door Phone Interface Module (DPIM).

- 1) Connect the Door Phone Interface Module (DPIM) line jack to any DLI port in the OfficeServ 7100 system using twisted pair (24AWG/26AWG). Use MMC 221 to assign a directory number to the doorphone. [See figure 7.10.](#)
- 2) Connect the Door Phone to the DPIM-door box jack using 4 conductor twisted pair cable. [See figure 7.10](#) for power and voice pair pin assignments.
- 3) If required connect a custom provided door lock to the lock contact pair on the DPIM using twisted pair wire (24/26 AWG) as indicated in [figure 7.10.](#)

The door lock contact pair is designed to control a low-voltage relay rated at 24VDC and 100mA. Do not attempt to connect commercial AC power to these contacts.



NOTE

MMC

[MMC 211](#) is used to assign call numbers to door phones. Use [MMC 501](#) to program duration of contact closure. [For detailed instruction on the MMC program, refer to OfficeServ 7100 Programming Section.](#)

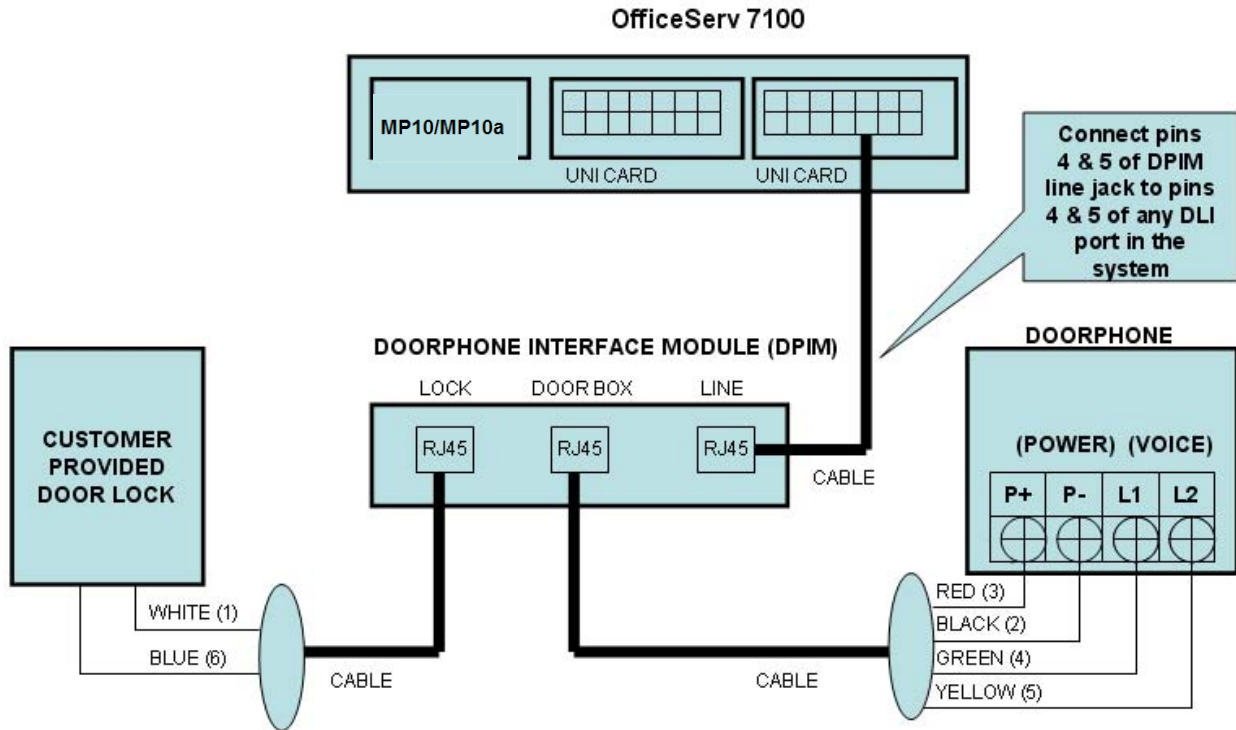

Figure 7.10 Connecting a Door Phone and a Door Lock

7.1.7 Connecting KDBF

Keypad Daughterboard module installed on a speakerphone connected to the OfficeServ 7100 system. The module enhances the function to full-duplex functionality.

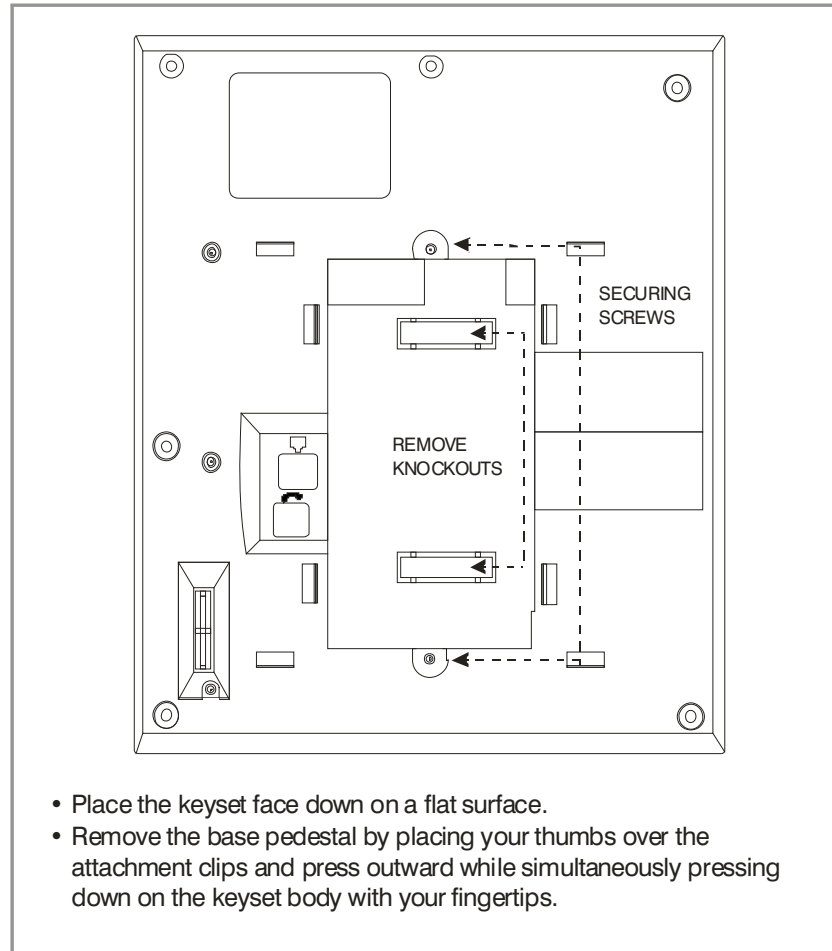

Figure 7.11 Adding an iDCS KDBF Keypad Daughtercard Module

iDCS KDB-FULL DUPLEX (FKDBF)

This daughtercard can only be installed in the iDCS 28 and iDCS 18 button phones. The standard speakerphone mode of operation for an iDCS keypad is "half duplex". This means that you cannot transmit and receive speech at the same time. Adding a FKDBF to your keypad will convert the speakerphone into full duplex mode enhancing its operation. In addition, the FKDBF may have up to 3 external microphones attached to it for conference room type applications. These microphones require an "EXTMIC" key programmed on the keypad to activate or deactivate them. ([See Figure 7.11](#)).

DS KDB-FULL DUPLEX (KDBF)

This is a daughtercard that can only be installed in the 21D or 14D button keysets. The standard speakerphone mode of operation for a DS keyset is “half duplex”. This means that you cannot transmit and receive speech at the same time. Adding a KDBF to your keyset will convert the speakerphone into full duplex mode enhancing its operation. In addition the KDBF may have up to 3 external microphones attached to it for conference room type applications. These microphones require an “EXTMIC” key programmed on the keyset to activate or deactivate them.

The KDB-D/KDB-S daughterboards are not supported on the iDCS and DS keysets when connected to the OfficeServ 7100 system.

7.1.8 Wall-Mounting Keysets

WALL-MOUNTING iDCS KEYSETS

iDCS keysets come equipped with a reversible base wedge. To wall-mount a keyset, remove the wedge from the keyset and mount the wedge to the wall using one of the methods below ([see Figure 7.12](#)).

Use screw holes 1 and 2 to attach the base wedge to a standard electrical outlet box.

OR

Use screw holes 1 and 3 to attach to a standard telephone wall-mount plate with locking pins. This method can cause the keyset to wobble as the keyset feet do not fit securely to the mounting surface.

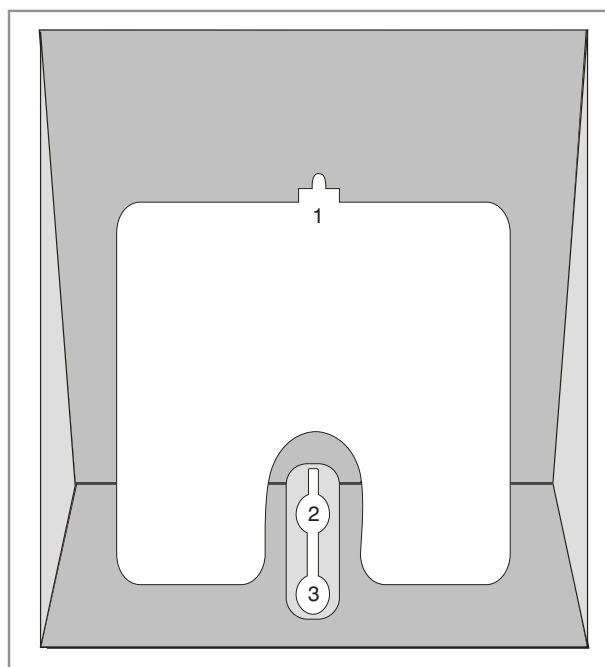

Figure 7.12 Wall-Mounting an iDCS Keyset

WALL-MOUNTING DS, ITP-5121D and ITP-5107S KEYSETS

DS, ITP 5121D and ITP 5107S keysets come equipped with a reversible base stand. To wall-mount a keyset, remove the base stand, reverse it, and attach stand in the bottom slots of the keyset. Use screw holes 1 and 2 to attach the keysets to the wall ([see Figure 7.13](#)).

To secure the handset once you have wall-mounted your keyset, you must remove the handset retaining clip and reverse it such that the extended clip is facing the top of the phone ([see Figure 7.13](#)).

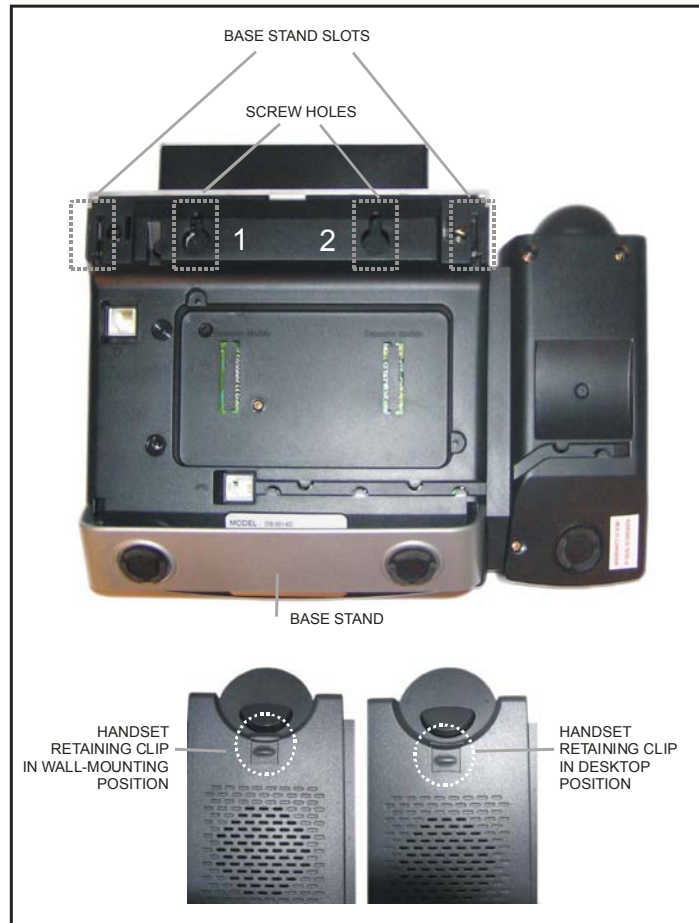
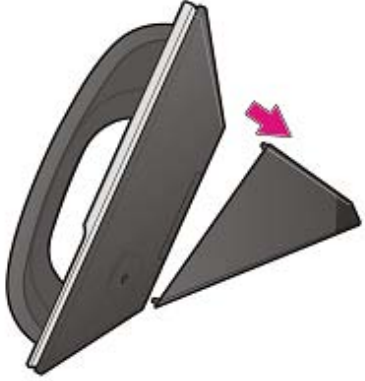

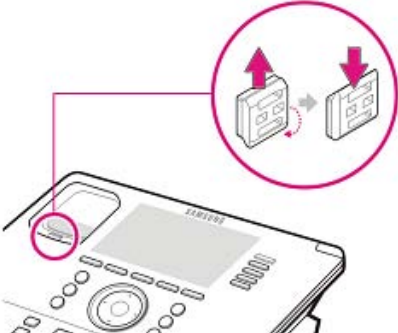

Figure 7.13 Wall-Mounting DS 5000, ITP-5121D and ITP-5107S Keysets

WALL-MOUNTING SMT-i5200 KEYSETS

Assemble the wall-mount bracket where you want to use the phone. The wall-mount bracket is an optional item.

To install the wall-mounting bracket follow the steps below:

<p>1. First, choose the location where you want to install the phone, and then determine the positions of the screws by placing the phone at the target location on the wall.</p>	
<p>2. Remove the desk cradle of the phone.</p> <ol style="list-style-type: none">Fix one latch of the cradle to the top or bottom groove of the phone.Push the remaining latch into the remaining groove on the opposite side.	
<p>3. Insert the wall-mount bracket as shown in the figure.</p>	
<p>4. Pull out the handset rack, and then insert it in the opposite direction, as shown in the figure.</p> <p>Only the up-down direction changes. The front-back remains unchanged.</p>	
<p>5. Install the phone on the wall.</p>	

To detach the wall-mounting bracket follow the steps below:

1. You can detach the phone from the bracket by pressing the **[Push]** section at the bottom of the bracket.

Detach the phone more easily by pulling the entire bottom of the bracket instead of only the **[Push]** section.

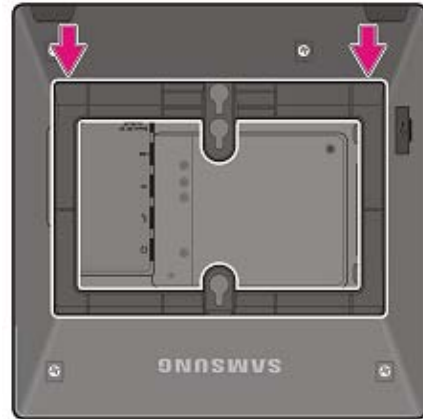

2. Pull out the handset rack, change the direction and then insert it again.



WALL-MOUNTING SMT-i3105 KEYSETS

The SMT-i3105 keysets do not require an optional wall-mounting bracket.

To wall-mount the SMT-i3105 follow the steps below:

1. First, choose the location where you want to install the phone, and then determine the positions of the screws by placing the phone at the target location on the wall.

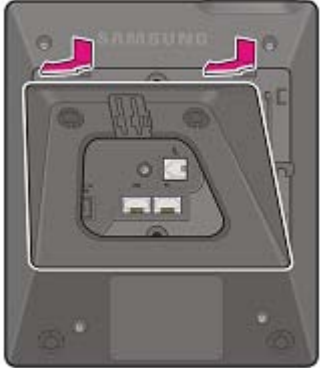
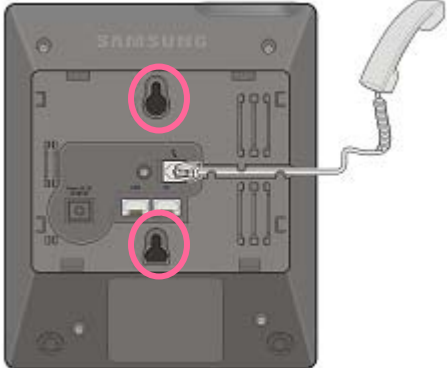
<p>2. Remove the cradle of the phone by pressing the [Push] mark on the top of the cradle to push it out</p>	
<p>3. Use screw holes 1 and 2 to attach the base wedge to a standard electrical outlet box.</p>	

7.1.9 Attaching Add-On Modules (AOMs) to Keysets

MAXIMUM AOM CAPACITIES

	Maximum per Station	Maximum per System
TDM 64 Button AOM	2	Limited by available DLI ports
IP 64 Button AOM	2	Limited by available IP/Virtual Ports

ATTACHING iDCS 64 BUTTON MODULES TO AN iDCS KEYSET

First, remove the base wedge from the iDCS 64 button module and attach the bracket to it with two of the screws provided ([see Figure 7.14](#)).

Remove the base wedge of the keyset and place it to the right of the 64 button module and attach the bracket/64 button module to the keyset with the remaining two screws.

The base wedge can now be replaced.

NOTE: If you wish to attach two 64 button modules to a keyset, connect the 64 button module together first and then attach them to the keyset.

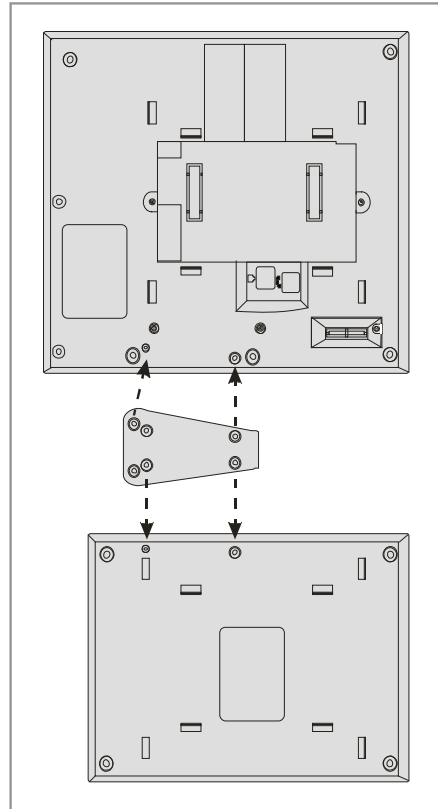

Figure 7.14 Attaching iDCS 64 Button Module to an iDCS Keypad

ATTACHING iDCS 14 BUTTON AOMs TO AN iDCS KEYSSET

To add an iDCS 14 Button Key Strip to your iDCS keyset, follow these steps: [\(see Figure 7.15\)](#)

- 1) Place the keyset face down on a flat surface.
- 2) Remove the base pedestal by placing your thumbs over the attachment clips and press outward while simultaneously pressing down on the keyset body with your fingertips.
- 3) Remove the ribbon cable knockout from the bottom of the keyset.
- 4) Clip the 14 button strip to the side of the keyset.
- 5) Plug one end of the ribbon cable into the keyset and the other end into the 14 button strip.
- 6) Place the support bracket over the ribbon cable and secure with the six screws provided.
- 7) Reattach the base pedestal.

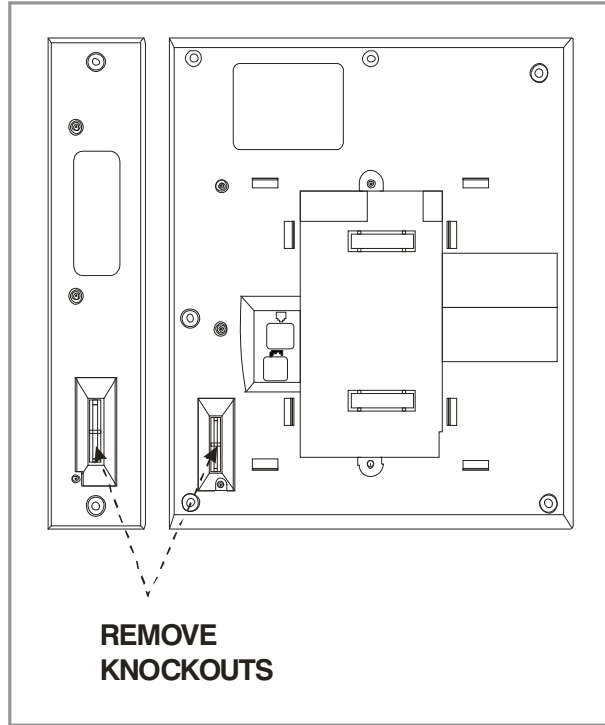

Figure 7.15 Attaching iDCS 14 button AOM to an iDCS Keyset

ATTACHING DS 64 BUTTON MODULES TO A DS 5021D OR A DS 5014D KEYSSET

First, attach the bracket to the keyset with two of the screws provided. Then attach the 64 button module to the bracket with the remaining two screws. ([See Figure 7.16](#)).

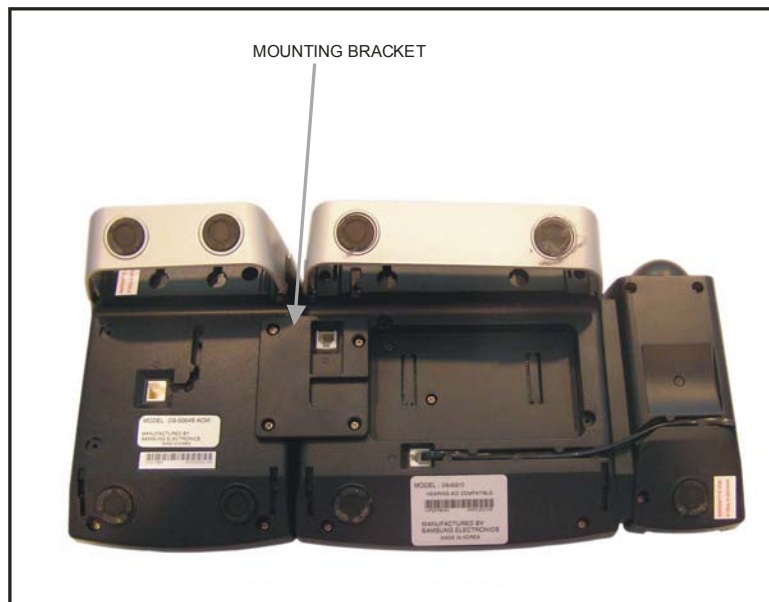

Figure 7.16 Attaching DS 64 Button Module to a DS 5021D or a DS 5014D Keyset

SMT-i5264 ADD ON MODULE

The SMT-i5264 module can be used beside any ITP 5100 keysets, SMT-i Series, and TDM phones . The cosmetic design matches the SMT-I 5000 Series phones. The SMT-i5264 Add On Module only attaches to SMT-i5200 Series.

To attach the SMT-i5264 AOM to any SMT-I 5000 Series phones follow the steps below:

- 1) Remove the SMT-i5264 AOM stand and the cradle of the phone by pressing the [Push] mark on the top of the cradle to push it out.
- 2) Attach the bracket to the keyset with two of the screws provided.
- 3) Attach the SMT-i5264 AOM module to the bracket with the remaining two screws.
- 4) To connect to the phone, connect the UTP cable between the port and the LAN port of the IP phone. [\(See Figure 7.17\).](#)
- 5) To connect to the switch, connect the UTP cable between the LAN port and a port of the switch.
- 6) Add the stands back to the phone and AOM unit.

NOTE: SMT-i5264 AOM requires either PoE or a Power Adaptor (sold separately).

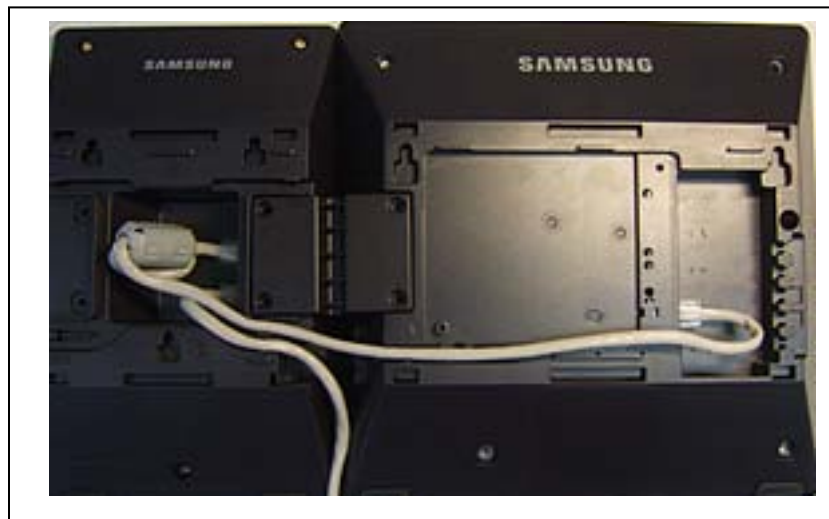

Figure 7.17 Attaching SMT-i5264 AOM to phone

If PoE is used, PoE connection should be connected to the LAN port of the SMT-i5264 (AOM) first then transfer over to the phone. As shown in Figure 7.17 the SMT-i5264 (AOM) can transfer the power from the LAN port to the phone port, but the phone can't transfer power to the AOM.

SETTING-UP SMT-i5264 AOM

SMT-i5264 AOM will register to the OfficeServ system as an IP phone device. It needs the IP phone ID and password during the registration. The SMT-i5264 will receive an IP phone extension. It can be paired to any IP phone or digital phone as the add-on module. MMC 209 is used to pair the AOM extension to a master phone.



Figure 7.18 Setting-Up SMT-i5264 AOM

- Prepare AOM to the set up mode
 - Press and hold 2nd key from the 1st column (left most columns) to enter the set up mode.
 - Press the 3rd key from the 4th column (right most columns) after this key is flashing.
 - (Press the 2rd key from the 4th column (right most columns) after this key is flashing will default the AOM to the factory settings.)
- Two methods to set up the AOM
 - Use SMT-i5243 phone to set up the AOM.
 - Enter SMT-i5243 phone to the engineering mode
 - Menu -> phone -> phone information -> *153#
 - Select Network -> AOM to enter into the set up mode
 - Enter the following data
 - If IP setting is DHCP skip this step
 - IP address: (assign an AOM IP address)
 - Gateway: (from MMC 830)
 - Subnet Mask: (from MMC 830)

- Server IP Address: (OfficeServ IP address from MMC 830)
- (use navigation key to move to the following fields)
- Server ID: (ITP ID from MMC 840)
- Server Password: (ITP password from MMC 840)
- Server Port: **6000 (press * key twice to switch input mode to numeric mode)**
- Use Web UI
 - Type IP address with port 8080 in the address bar of IE browser. Default AOM IP address is 10.0.0.3.
 - Ex.
 - <http://10.0.0.3:8080>
 - ID: admin
 - Password: samsung
 - Fill in the required data. Must enter the following information.
 - Server IP address is the OfficeServ MP IP address
 - Ex. 192.168.1.10
 - Enter an ITP ID and password
 - Ex:
 - id: 3210
 - pw: 1234
 - default port is **6000**
 - Press [Save] then [ReStart]
 - Use **MMC 209** to pair AOM to any IP/TDM phone.
 - Use MMC 722 to assign buttons.

		Server IP Address	105.52.21.37	Connected	
SYSTEM INFORMATION	Multi Server	ID / Password	ID : 6901	Password : ****	PORT : 6000
		2nd Server IP Address	10.0.0.2		
		ID / Password	ID :	Password :	PORT : FFFFFFFF
		3rd Server IP Address	10.0.0.2		
		ID / Password	ID :	Password :	PORT : FFFFFFFF
NETWORK	MAC Address	00-16-32-cd-44-60			
	Connection Mode	Static IP (selected) / DHCP			
	IP Address	105.52.21.156			
	Subnet Mask	255.255.255.0			
	Default Gateway	105.52.21.1			
VLAN	AOM	Use	Not Us		
	PHONE	ID / Priority	ID [2 ~ 4094] : 2	Priority : 7	
802.1x	Use	Not Us			
	ID / Password	ID :	Password :		
UPGRADE	S/W Version	V01.10(0812010900)			
	Server IP	105.52.21.194			

Figure 7.19 IP AOM Network Configuration

7.1.10 Connecting the SMT-A52GE Gigabit Adaptor

The Gigabit Adaptor processes the Gigabit data for a Gigabit LAN connection on the PC connected to the SMT-i5200 series IP phone.

COMPONENTS

The SMT-A52GE comes with the following components:



Gigabit Adaptor



2 Fixing Screws



LAN Cable

CONFIGURATION AND FUNCTIONS

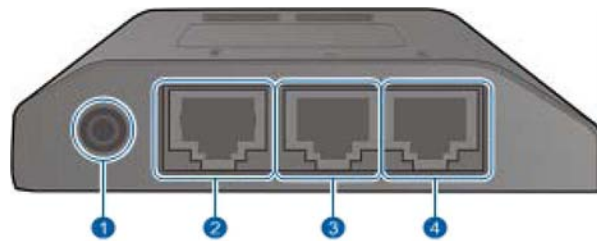

Port	Function
① Power (DC 5 V)	DC power adaptor connection port
② IP Phone PSE	<ul style="list-style-type: none"> A port connected to the IP phone's LAN port via the LAN cable. This is shipped together with the Gigabit Adaptor (10/100BASE-TX) If PoE (Power over Ethernet) is provided via the G-LAN PD port, it supplies PoE to the IP phone.
③ G-PC	<ul style="list-style-type: none"> LAN cable port connected to the PC (10/100/1000BASE-T)
④ G-LAN PD	<ul style="list-style-type: none"> LAN cable port connected to the network (10/100/1000BASE-T) If PoE is supplied via the LAN, a power supply is not required for the IP phone or adaptor.

NOTE: DC power adaptor is not included.

HOW TO CONNECT TO A PHONE

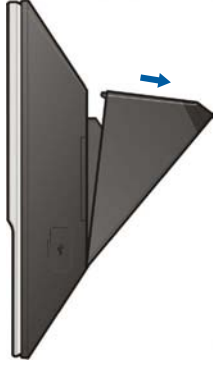
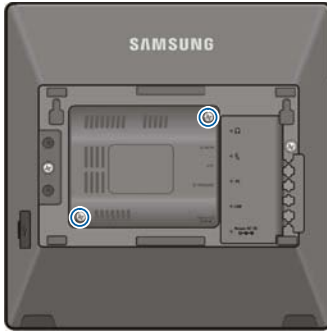
<p>1. Separate the cradle at the back of the phone.</p>	
<p>2. Mount the Gigabit Adaptor onto the back of the body.</p> <p>NOTE: The back of the Gigabit Adaptor is sharp, so take care to avoid injury. When you connect the Gigabit Adaptor to the IP phone which is currently in use, disconnect the PC cable connected to the IP phone, and connect it to the G-PC port of the Gigabit Adaptor. This will leave the PC connection port, usually used for the IP phone, vacant.</p>	

3. Connect the cable.

When PoE is supplied via the LAN:

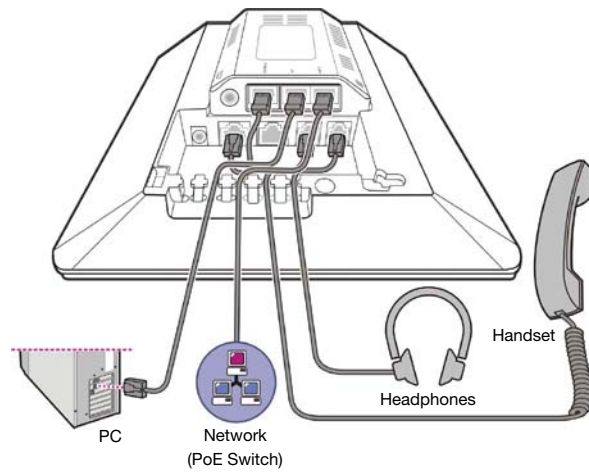

When PoE is not supplied via the LAN:

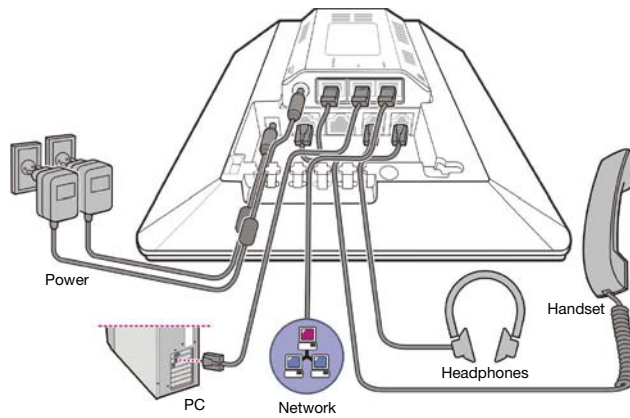

4. Attach the cradle to the back of the phone.

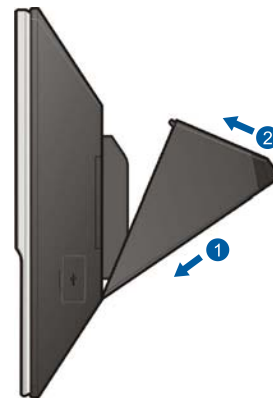

7.1.11 Connecting a Wireless LAN Access Point

Wireless LAN service offered by the OfficeServ 7100 system requires the following equipment:

1. SMT-R2000: Wireless LAN Access Point (AP)
2. SMT-W5100E: Wireless LAN IP Phone

Item	OfficeServ 7100 System (Basic Cabinet)
Maximum Number of Users	24
Number of Simultaneous Users	MMC 845 Setting

Table 7.2 Specification for Wireless LAN Connection

REFERENCES: For information on how to install and use SMT-R2000 and SMT-W5100E, refer to Wireless Documentation.

Connect 4SWM board and SMT-R2000 WAN port by using RJ-45 Ethernet cable (100m maximum distance). SMT-R2000 does not need to connect to additional power because it can get power through 4SWM which supports PoE.

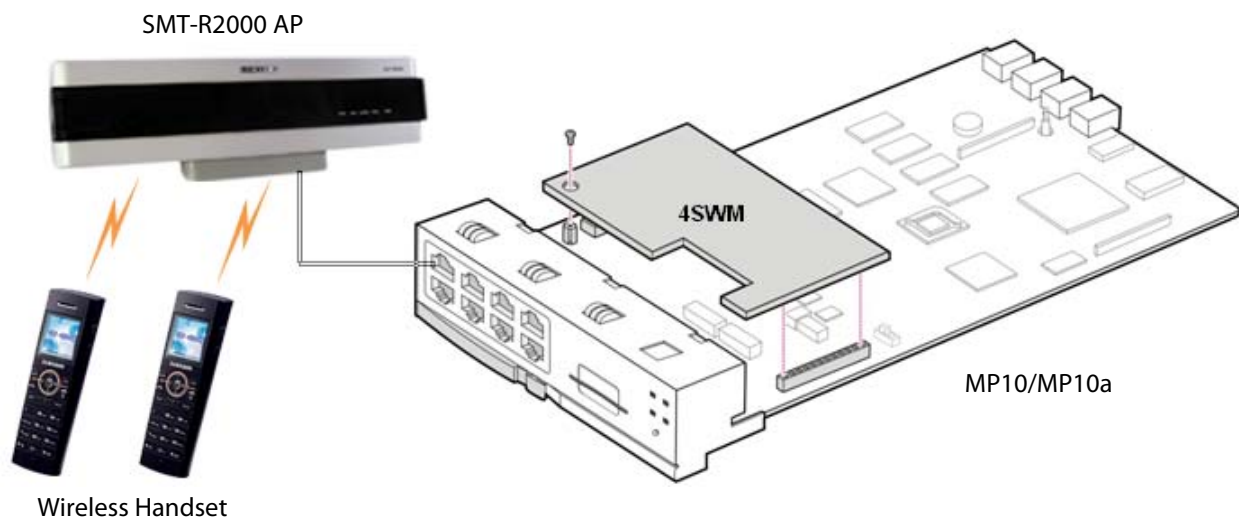

Figure 7.20 Connecting Access Point to Ethernet Port

7.2 CONNECTING ADDITIONAL EQUIPMENT

This section describes how to connect optional equipment, such as Music on Hold (MOH)/Background Music (BGM) sources, external page devices, common bells, and PCs for OSM/SMDR/CTI, to the OfficeServ 7100 system.

The following table lists the default MISC Numbering Plan defined in MMC 724.

MISC FUNCTION # IN MMC 724	DEFAULT DN	HARDWARE ITEM
01	371	MOH/BGM
02 (Voice)	361	Page Tip and Ring
03 (Relay 1)	362	Dry Contact (MMC 218)
04 (Relay 2)	363	Dry Contact (MMC 218)
05	3999	Internal Modem

7.2.1 Connecting MOH/BGM Equipment

The OfficeServ 7100 system offers Music on Hold. The system provides internal tone/music and external music sources per C.O. or extension lines as the music source.

One external MOH source connection is provided on the MP10/MP10a MISC port. Connect the music source to this MISC port of the MP10/MP10a card.



NOTE

IMPORTANT NOTICE: In accordance with US copyright law, a license may be required from the American Society of Composers, Authors and Publishers (ASCAP) or another similar organization if copyrighted music is transmitted through the Music on Hold feature. Samsung Telecommunications America hereby disclaims any liability arising out of failure to obtain such a license.

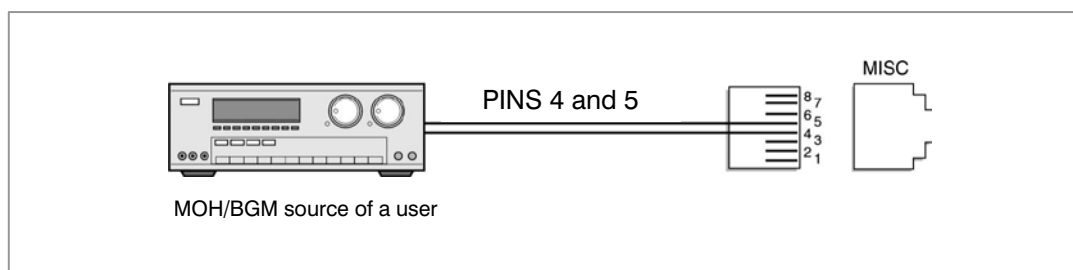



Figure 7.21 Connecting MOH/BGM Sources

- The MISC port located on the front panel of the MP10/MP10a.

 NOTE	<p>MMC</p> <p>Select music sources for C.O. lines in MMC 408 and music sources for extensions in MMC 308. For detailed instructions on the MMC programs, refer to OfficeServ 7100 Programming Manual.</p>
---	--

The following ports are assigned to the external MOH inputs on the MIS daughtercard:

HARDWARE ITEM	MISC FUNCTION # in MMC 724	DEFAULT DN (Ports)
MOH/BGM Ext. Source	01	371

7.2.2 Connecting External/Additional Page Equipment

Instead of an internal speaker, external broadcasting equipment, such as amps or speakers, and additional equipment that can broadcast page ring) signals outside a building can be connected to the OfficeServ 7100 system.

Connect external/additional paging equipment to the MP10/MP10a MISC port. The power of the external/additional paging equipment should be connected separately.

The MP10/MP10a MISC port provides a voice pair and a one dry contact to be used with customer-provided paging equipment. Connect the customer-provided paging equipment to the page output pins of the MISC port ([see Figure 7.22](#)).

The Page Zone Relay ports assigned to the dry contact pair are listed in the following table. Assign the DN number to the selected page zone using Default DN (Ports).

HARDWARE ITEM	MISC FUNCTION # in MMC 724	DEFAULT DN (Ports)
Page Tip & Ring (600 ohms)	02	361
Contact Pair #1	03	362
Contact Pair #2	04	363

- MISC port is located on the front panel of the MP10/MP10a.

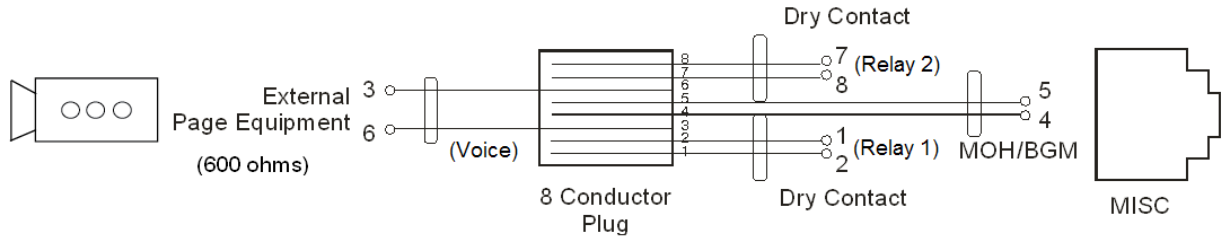

Figure 7.22 Connecting External/Additional Page Equipment



Dry Contact

Dry Contact is a switch that can connect or cut the power or line to external equipment.

7.2.3 Loud Bell Interface

When a station requires loud ringing, assign or pair that station to an audible ring tone output on the MISC port using MMC 205. Relay type can be assigned to Loud Bell in MMC 218.

MISC FUNCTION # in MMC 724	DEFAULT DN
03~04	362 or 363

Next, connect the output MISC port to a customer provided paging system or other suitable customer provided speaker ([see Figure 7.23](#)).

7.2.4 Connecting Common Bell

A customer-provided loud ringing device can be controlled using a dry contact pair on the MP10/MP10a MISC port.

Common bell connections should be wired to the MP10/MP10a MISC port.

By using MMC 204, programming allows for interrupted or continuous operation of the contacts. The interrupted selection follows the CO ring cadence, 1 sec ON/3 sec OFF. Relay type can be assigned to Common Bell in MMC 218.

MISC FUNCTION # in MMC 724	DEFAULT DN
03 or 04	362 or 363

The OfficeServ 7100 system supports only one dry contact for the common bell. The MISC port is located on the front panel of the MP10/MP10a.

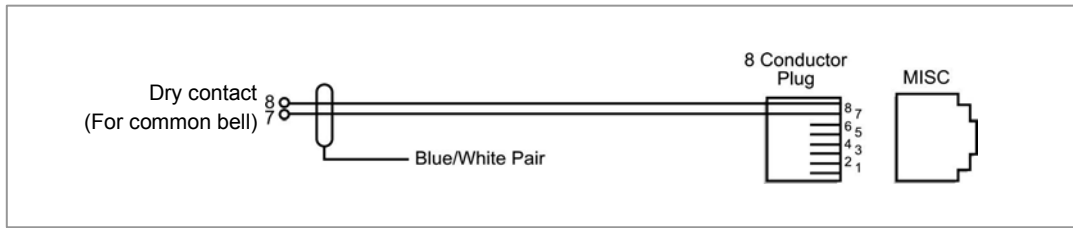

Figure 7.23 Connecting Common Bells

WARNING: Do not attempt to connect commercial AC power to these contacts.

- 1) After connecting a common bell, you must assign it in MMC 601 to a group as a ring destination by using the code for common bell.
- 2) After wiring to the contact pair, set contacts for continuous or steady operation.
- 3) Next, program hunt group to include the common bell.
- 4) Assign the trunk to ring the hunt group containing the common bell. Common bell control can be used with station hunt groups, individual stations and universal answer.

7.2.5 Ring Over Page

When a customer-provided paging system is installed, incoming calls can be assigned to ring over page. Program the C.O. line or C.O. lines to ring a hunt group. Using MMC 601, assign the DN number of the Page Output (voice) for the MISC port being used as a member of the group or as the NEXT PORT for the overflow destination. Other stations may be assigned to the same group to provide ringing to phones and the paging system at the same time.

MISC FUNCTION # in MMC 724	DEFAULT DN
02	361

7.2.6 Connecting OfficeServ Installation Tool

Installation Tool is a computer application that provides various maintenance and management functions for the OfficeServ 7100. The minimum requirements for a PC running Installation Tool are as follows:

Table 7.3 Installation Tool Specification

Category	Specification
Platform	IBM PC
CPU	Pentium III or higher
OS	Windows 2000 or higher
Main Memory	64Mb or higher
Hard Disk	1Gb or higher

CONNECTING INSTALLATION TOOL (OIT) TO LAN PORT

The OIT application can communicate to the OfficeServ 7100 system via the LAN or MODEM connection. The OIT can connect to the MP10/MP10a via LAN connection using a customer provided LAN switch or using the 4SWM module as shown in [Figure 7.24](#).

- Set up the MP10/MP10a LAN parameters in MMC 830.
- If an MP10/MP10a is behind a firewall and the OIT is outside the firewall, ports 5090 and 5003 must be open to the private IP address of the MP10/MP10a.

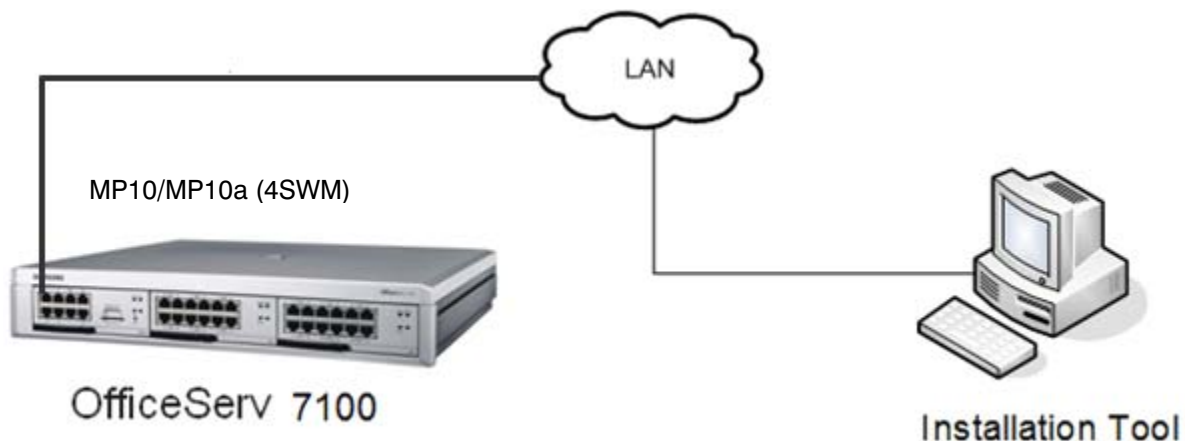

Figure 7.24 OIT Connection to LAN Port

Detail procedures for each of the steps above are as follows:

SETTING NETWORK PARAMETERS THROUGH MMC 830

Set the network parameters of the system. Contact the network manager when setting values for the network parameters.

- 1) Set the IP address of the system.
- 2) Set the subnet.
- 3) Set the gateway address.
- 4) Reset the MP10/MP10a.



MP10/MP10a Reset

New settings are applied only after the card is reset. The system may malfunction if the card is not properly initialized.

INSTALLATION TOOL AND LAN CONNECTION

1. Execute OIT.
2. Click [System] -> [Link Control] menu to set the communications link.

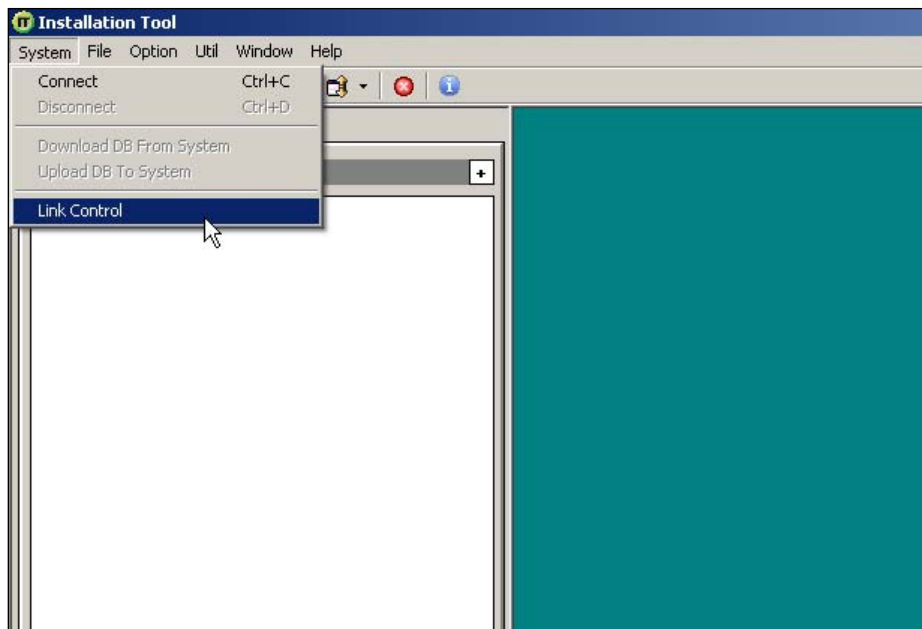

Figure 7.25 OIT and LAN Connection

3. Enter System name (e.g. ABC Company).
4. Select the <link type> (e.g. LAN).
5. Input the IP address (e.g. 192.169.9.209).
6. Click [Apply].
7. Dialog box shows: "Do you want to apply new setting value?"
8. Click [Yes].
9. Dialog box shows: "The new setting value is applied."
10. Click [OK]. Click [Close].
11. Click [System]. Click [Connect].
12. Enter Password [Samsung], then [OK].

INSTALLATION TOOL AND MODEM CONNECTION VIA TELCO LINE

This example is based on a PC using an internal modem card. Connect Telephone line cord from internal modem connection of PC directly to loop start telco line.

1. Execute OIT.
2. Click [System] -> [Link Control] menu to set the communications link.
3. Enter System Name (e.g. ABC Company).
4. Select the <link type> (e.g. MODEM).

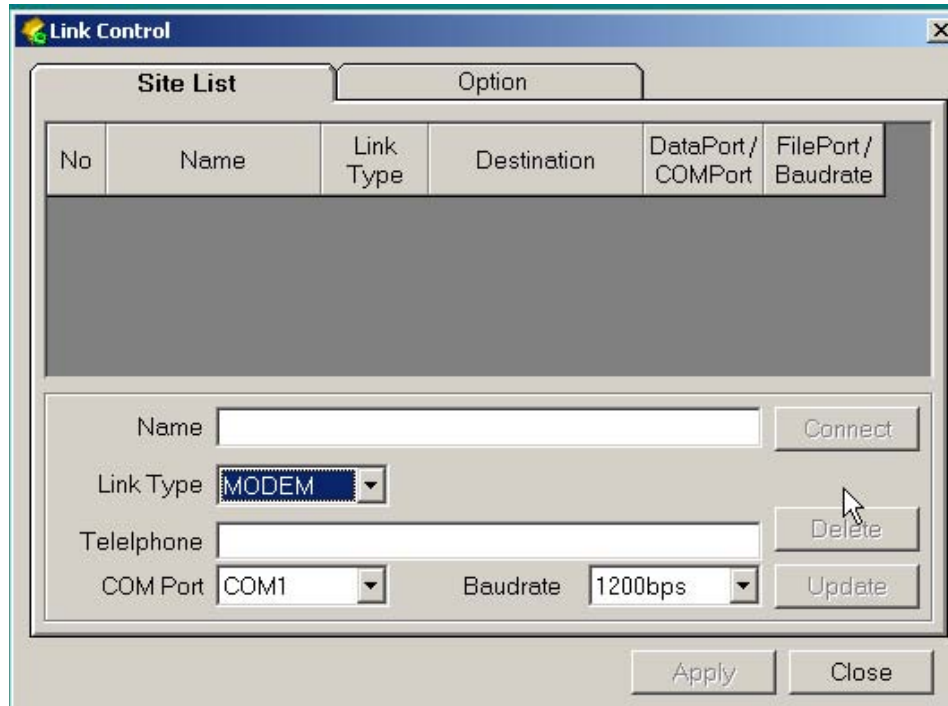

Figure 7.26 OIT and Modem Connection

5. Input the Telephone number (e.g. 972-372-4812).
6. Input the Com Port (e.g. COM1).
7. Input the Baud Rate (e.g. 38400bps).
8. Click [Apply].
9. Dialog box shows: "Do you want to apply new setting value?"
10. Click [Yes].
11. Dialog box shows: "The new setting value is applied."
12. Click [OK]. Click [Close].
13. Click [System]. Click [Connect].
14. Enter Password [Samsung], then [OK].

NOTE: Internal modem card must be installed for the connection to work. The incoming telco line may need to be programmed to ring directly to modem port of OfficeServ 7100 system in MMC 406 (e.g. Trunk 701 ring to port 3999).

7.2.7 SYSTEM DATA/ACTIVITY REPORTS

The following type of reports can be output to a PC or LAN printer that is connected to the same network as the MP10/MP10a: SMDR (Station Message Detail Records), UCD Reports, Traffic Reports, Alarm Reports and much more. [Refer to MMC 829](#) to configure the report type and data output network configuration ([See OfficeServ 7100 Programming Manual](#)). This MMC can also configure the reports to be sent to PCs running 3rd party applications (i.e. SMDR Reporting Packages, etc.).

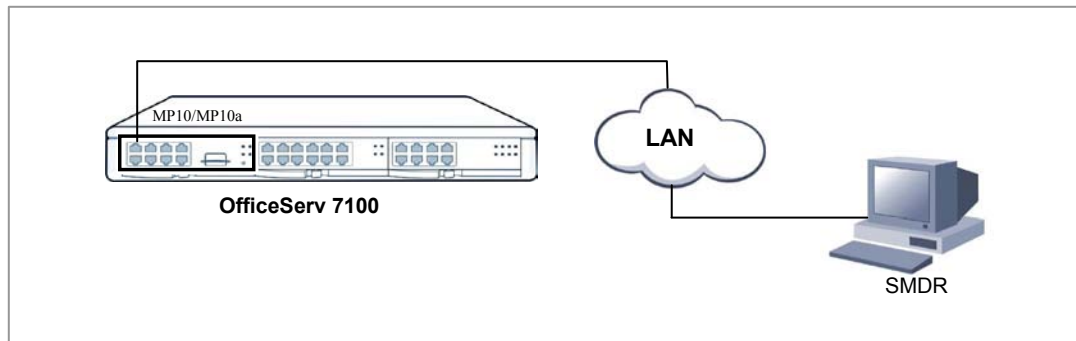

Figure 7.27 Connecting SMDR

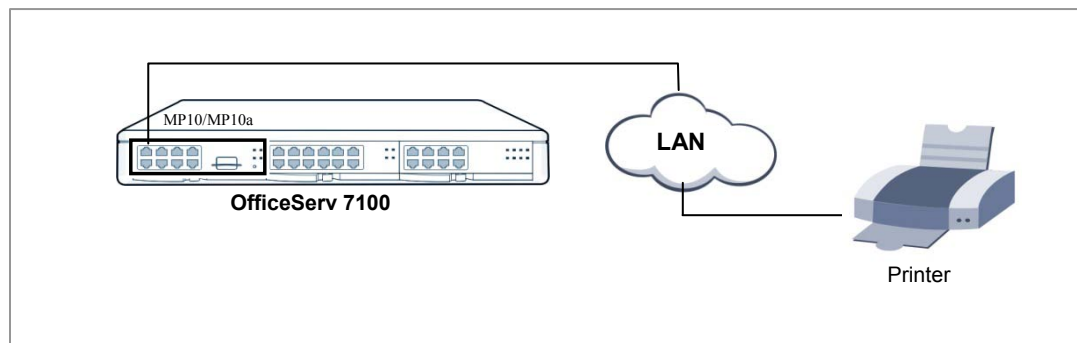

Figure 7.28 Connecting to Printer

7.2.8 OS 7100 and ANALOG TERMINAL ADAPTERS (ATAs)

The OfficeServ 7100 can be SIP enabled (SIP licenses required) to interface with other 3rd party analog terminal adapters (ATA) devices, to provide voice connectivity to a VoIP network. The SIP enabled adapters can be used to support specialized voice applications such as:

- VoIP connectivity to remote analog stations.
- VoIP connectivity to remote Fax Machines.
- 911 routing to remote SIP-PSTN Gateway.

These 3rd party analog terminal adapters (ATA) are not available through Samsung, and must be purchase separately. [For more details, please refer to the special application section 2.11 of the manual.](#)

PART 8. POWER UP PROCEDURES

This section describes items to check before starting the OfficeServ 7100 system and the procedure for starting the system.

8.1 PRE-CHECK

This section describes items to check before starting the OfficeServ 7100 system.

8.1.1 Safety Precautions

- **Temperature:** Check if the temperature of the room where the system is installed is between 32°F and 113°F. If the room temperature is higher or lower than the normal operation temperature, install a heating/cooling device to maintain normal temperature.
- **Humidity:** Check if the room humidity where the system is installed is between 10% and 90%. Take special caution since humidity affects the electrical components and connectors of the system.
- **Direct sunlight and dust:** The room where the OfficeServ 7100 system is installed should be protected from direct sunlight and should have ventilation systems to prevent the system from malfunctioning due to dust.

8.1.2 Safety Conditions

The building where the OfficeServ 7100 system is installed should have lightning rods and grounding to protect the system against lightning and electric leakage.

- Check if the OfficeServ 7100 system is not inclined and is maintained horizontally.
- Do not place devices that may cause electromagnetic interference near the system.
- Place a fire extinguisher near the system.
- Check if the AC voltage switch of the PSU is properly set to 110VAC power.
- Check if the grounding terminal on the rear panel of the system is properly connected to the external grounding.

8.2a STARTING THE SYSTEM (MP10)

The procedure for starting the OfficeServ 7100 system is as follows:

- 1) Check if the cards and cables are properly mounted and connected to the OfficeServ 7100 cabinet.
- 2) Make sure the MP10 MMC+/SD Card with system software is in the Media slot.
- 3) Make sure the memory backup switch on MP10 is in the ON position.
- 4) Turn on the power of the OfficeServ 7100 cabinet.
- 5) Check the LEDs of the MP10.

- 6) The RUN LED of the MP10 card lights green and the MC LED flashes when the system normally starts the booting process.
- 7) Once the booting is complete, the RUN LED of the MP10 card flashes green, and the MC LED stops flashing and remains lit. (It takes approximately 2 ½ to 3 minutes to boot up).
- 8) Enable MGI channels by entering the appropriate license key in system programming (if MGI services are required).



NOTE

If the MP10 MMC+/SD card is not detected

If the system cannot detect the MP10 MMC+/SD card, the MC LED might not light or flash. In such cases, turn off the power, replace the MP10 MMC+/SD card and turn the power on again. If the MP10 MMC+/SD card is still not detected, turn off the power and replace the MP10.

- 9) Check if the LED status of other interface cards is normal.



NOTE

If the LED status of the MP10, or interface card is abnormal, turn off system power and turn the power on again.

8.2b STARTING THE SYSTEM (MP10a)

It is required to clear memory and start with a default database when using the new MP10a card. The MP10a card no longer has a battery switch to clear memory. The system memory is cleared to default by the performing the following procedure:

- 1) Check if the cards and cables are properly mounted and connected to the OfficeServ 7100 cabinet.
- 2) Make sure the MP10a SD Card with system software is in the Media slot.
- 3) To start MP10a from default (Clear memory): Power up the system and let the system begin to boot.
- 4) About 10 seconds into the bootup sequence, press in the RST (reset) switch on the front of the MP10a card.
- 5) Hold in the RST switch for approximately 7 to 10 seconds (this will default the database).
- 6) Release the RST switch and wait for system to complete the boot up process. Check the LEDs of the MP10a.
- 7) The RUN LED of the MP10a card lights green and the MC LED flashes when the system normally starts the booting process.
- 8) Once the booting is complete, the RUN LED of the MP10a card flashes green, and the MC LED stops flashing and remains lit (approximately 3 minutes).
- 9) When the system completes the bootup, the system memory is cleared and the database is at default.
- 10) Enable MGI channels by entering the appropriate license key in system programming (if MGI services are required).

11) Test system for normal operation.



If the MP10a SD card is not detected

If the system cannot detect the MP10a SD card, the MC LED might not light or flash. In such cases, turn off the power, replace the MP10a SD card and turn the power on again. If the MP10a SD card is still not detected, turn off the power and replace the MP10a.



If the LED status of the MP10a, or interface card is abnormal, turn off system power and turn the power on again.

8.2c UPGRADING MP10 with MP10a CARDS

Existing customers can be upgraded from MP10 to MP10a card to receive the improvements to the new processor. When this is required, the IT tool can be used to backup and restore the telephone setting of the customer's database, however the voicemail settings should not be saved. All voicemail prompts and stored messages and greetings must be deleted and re-recorded on the new MP10a card. This will insure that the customer will benefit for the improved audio qualities of the new MP10a card.

8.3 PRECONFIGURED NUMBERING OF EXTENSION AND CO LINES AND STATIONS

The OfficeServ 7100 has been designed as plug-n-play to operate right out of the box with minimum programming and little installation time required. The OfficeServ 7100 comes prepackaged with hardware to support 4 CO lines and 8 digital stations (Only 6 iDCS 28 button keyset are provided), and 4 ports of embedded voicemail. Other types of iDCS, DS, ITP Series, and SMT-I Series phones can be connected if necessary.

When the system is powered up, it will read the hardware components and self-configure a default database to support the following:

- iDCS 28 button phones (pre-labeled) in a squared 4 lines X 8 stations configuration
 - CO lines 701 through 704
 - Stations 201 through 208
 - Direct Station Select key (DSS) keys 201 through 208
 - Speed dial keys 01 through 05
 - Feature keys (Directory, Call Log, Group Listen, Intercom, DND)
 - 50 CID review blocks per station

- 50 Call Log blocks per station
- 50 Station speed dial buffers per station

- 500 System speed dial buffers
- Operator group 500 (normal) with members 201 through 208
- Voicemail group (BI-VMS) 519 with member 301 through 304

Six iDCS 28 button keyset are packaged with the OS7100 system and the line keys are preset and pre-labeled to support the OS7100 default configuration. If the iDCS 18 button keysets are connected to the OS7100 system they will also come up pre-configured to support the default line key layout. Please see the following diagrams for the iDCS 28 and 18 button line key defaults.

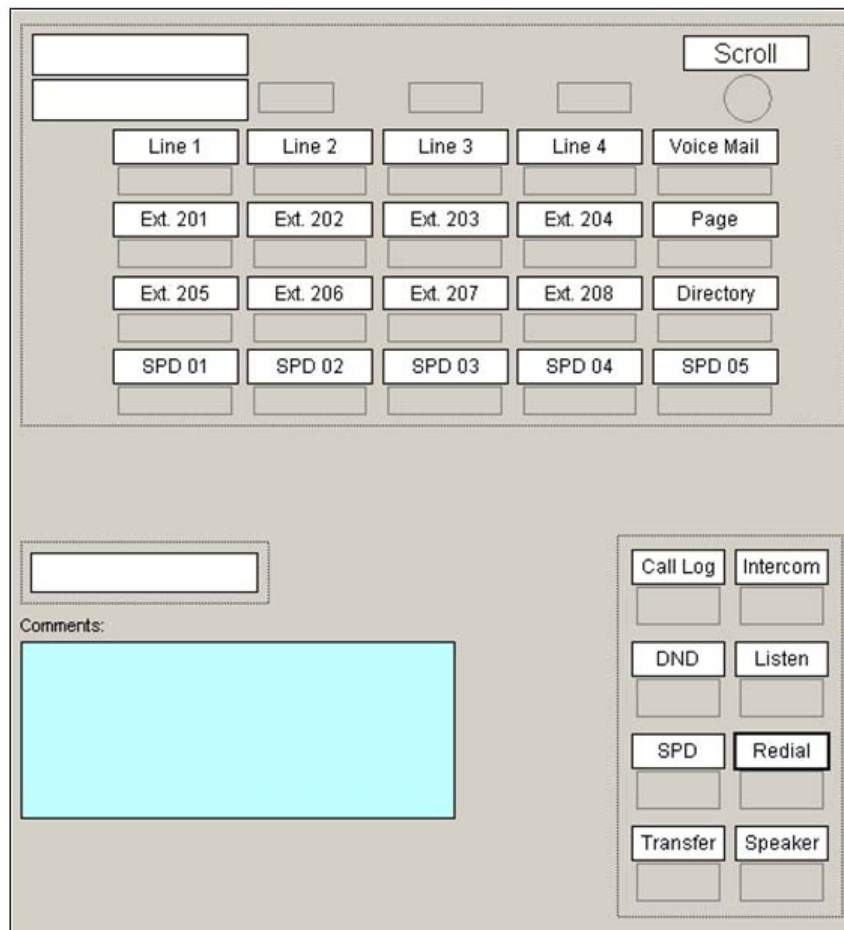

Figure 8.1 iDCS 28 Button Line Key Default

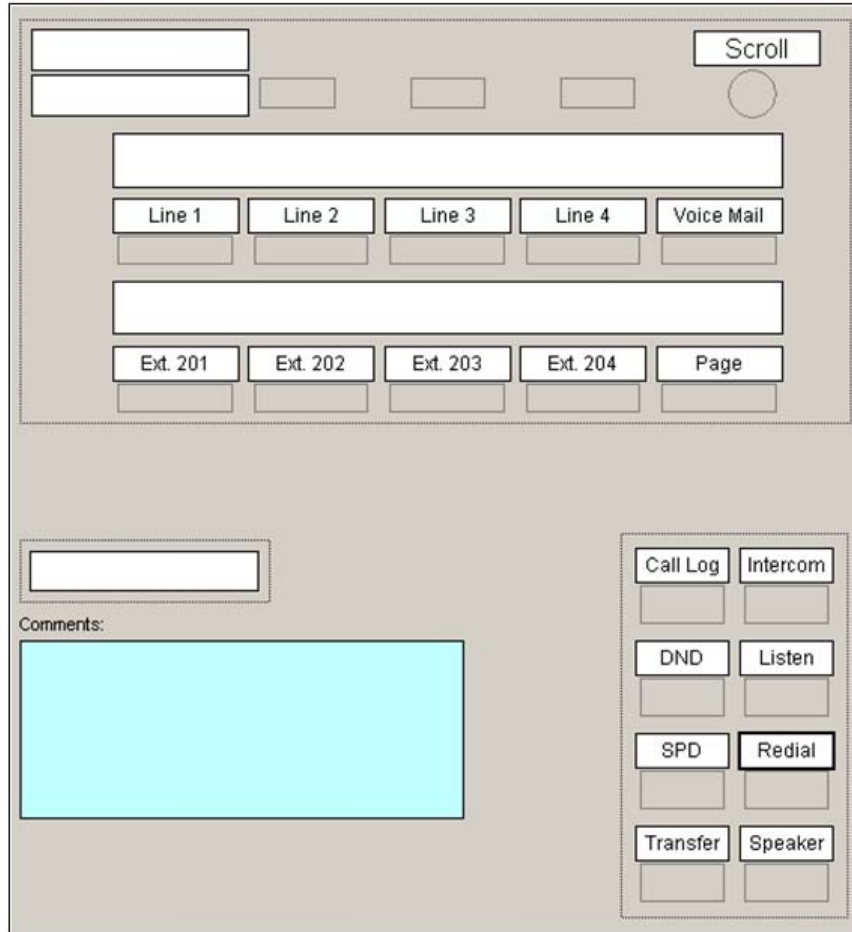

Figure 8.2 iDCS 18 Button Line Key Default

NOTE: Other types of iDCS, DS and ITP/SMT-i phones can be connected however the line keys will have a different default button configuration.

Once the OfficeServ 7100 system is booted, the MP10/MP10a card verifies the cards mounted on each slot and saves this information as the default configuration of the system. At default, the OfficeServ 7100 system assigns 3 digits to CO lines, extensions, and extension groups. Refer to [Section 3. Installing and Replacing cards](#) of this manual for details on switch 2.

CO line numbers from 701 through 7XX are sequentially assigned (by default) to the first CO line card installed in the system from left to right and following numbers are continuously assigned to the next CO line card of the next slot.

Extension numbers from 201 through 2XX are sequentially assigned to the first station type card mounted in the system from left to right (starting from 4DLM if mounted on the MP10/MP10a) and following numbers are continuously assigned to the next extension card of the next slot. This numbering process continues until the extension numbers are assigned to all extensions.

The first 8 ports are assigned to the operator group as default. Group 500 with members 201 through 208, and Voicemail Group 519 with members 301 through 304. The numbering plan of CO lines, extensions, and extension groups can also be changed in the database at any time using [MMC 724 \(STATION NUMBERING PLAN\)](#).

PART 9. SOFTWARE AND DATABASE MANAGEMENT

9.1a SOFTWARE MANAGEMENT WITH MP10 INSTALLED

The OfficeServ 7100 operating software, Voicemail/Auto Attendant software, and all saved messages and greetings are stored on the MP10 MMC+/SD card which is inserted into the media Ccard slot on the MP10. The MMC+ card has 256Mb of NAND flash memory and is formatted, with a custom format to allow faster loading, in a similar manner to a hard disk. The MP10 SD card has 1G of NAND flash memory and is formatted, with a custom format to allow faster loading, in a similar manner to a hard disk. The MP10 SD card also has the capability to store a backup copy of the system database in addition to the operating software files. The MP10 MMC+/SD card also has the capability to store a backup copy of the system database in addition to the operating software files.

Software can be downloaded from the MP10 MMC+/SD card to the cards listed above using MMC 818 and will be stored in those cards on-card flash memory. The cards will automatically reboot, load and run the new software when the download process is complete. Files can be deleted using MMC 819, File Control. This is necessary to manage files on the MP10 MMC+/SD card.

Using Installation Tool over a LAN connection to the system, the software files can be uploaded to the MP10 MMC+/SD card. The files are first uploaded to the MP10 card and then transferred to the MP10 MMC+/SD card. Once the files are loaded onto the MP10 MMC+/SD card they can be manipulated with MMC 818.

9.1b SOFTWARE MANAGEMENT WITH MP10a INSTALLED

The OfficeServ 7100 operating software, Voicemail/Auto Attendant software, and all saved messages and greetings are stored on the MP10a SD card which is inserted into the Media Card slot on the MP10a. The MP10a SD card has 1G of NAND flash memory and is formatted, with a custom format to allow faster loading, in a similar manner to a hard disk. The MP10a SD card also has the capability to store a backup copy of the system database in addition to the operating software files.

Software can be downloaded from the MP10a SD card to the cards listed above using MMC 818 and will be stored in those cards on-card flash memory. The cards will automatically reboot, load and run the new software when the download process is complete. Files can be deleted using MMC 819, File Control. This is necessary to manage files on the MP10a SD card.

Using Installation Tool over a LAN connection to the system, the software files can be uploaded to the MP10a SD card. The files are first uploaded to the MP10a card and then

transferred to the MP10a SD card. Once the files are loaded onto the MP10a SD card they can be manipulated with MMC 818.

9.2 DATABASE MANAGEMENT

The customer database can be saved to the media card using MMC 815 where it is stored as a single file. This save can be performed manually or the system can be programmed to save the database automatically at a designated time every day. Using Installation Tool, the database can be downloaded from the system and stored on the PC or it can be uploaded from the PC to the system. The database uploaded from Installation Tool is not stored on the media card but is loaded directly into active memory.

PART 10. ADDING CARDS TO THE SYSTEM

10.1 ADDING STATIONS AND TRUNKS

- 1) Power the OfficeServ 7100 OFF before adding a new card. Locate a suitable empty card slot. Having located a suitable slot, insert the new card into the slot and push firmly in the middle of the card to ensure that it is fully inserted into the back plane connector.
- 2) After the new cards are inserted, the system must be told to recognize the new cards. This is done through the use of MMC 806 Card Pre-Install. Use this MMC for each new card that is installed.
- 3) The new cards must be assigned directory numbers according to the system numbering plan in MMC 724. The technician must know the software port assignments of the new cards so the ports can be assigned correct numbers.