

Wideband RF LDMOS Integrated Power Amplifier 45 W, 1900 – 2200 MHz

Description

The PTMA210452FL and PTMA210452EL are wideband, 45-watt, 2-stage, LDMOS integrated amplifiers intended for use in all typical modulation formats from 1900 to 2200 MHz. These devices are offered in thermally-enhanced ceramic packages with solder-friendly plating for cool and reliable operation.

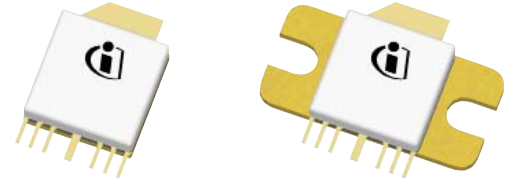

PTMA210452FL
 Package H-34265-8

PTMA210452EL
 Package H-33265-8

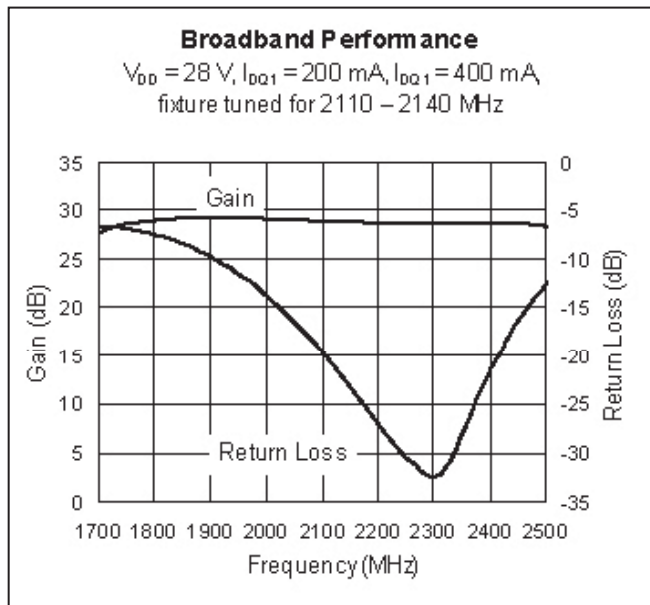

Features

- Designed for wide RF and modulation bandwidths and low memory effects
- Typical two-carrier WCDMA performance at 2140 MHz, 28 V
 - Average output power = 3.2 W
 - Linear Gain = 28 dB
 - Efficiency = 10.5%
 - IMD3 = -47 dBc
- Typical two-tone performance, 2140 MHz, 28 V
 - Output power (PEP) = 45 W at IM3 = -30 dBc
 - Efficiency = 32%
- Capable of handling 10:1 VSWR @ 28 V, 45 W (CW) output power
- Integrated ESD protection. Meets HBM Class 1B (minimum), per JESD22-A114F
- Thermally-enhanced packages, Pb-free and RoHS compliant, with solder-friendly plating

RF Characteristics

Two-carrier WCDMA Measurements (tested in Infineon test fixture)

$V_{DD} = 28\text{ V}$, $I_{DQ1} = 200\text{ mA}$ (tuned for linearity), $I_{DQ2} = 450\text{ mA}$ (tuned for linearity & efficiency), $P_{OUT} = 3.2\text{ W}$ average, $f_1 = 2135\text{ MHz}$, $f_2 = 2145\text{ MHz}$, 3GPP signal, channel bandwidth = 3.84 MHz, peak/average = 8 dB @ 0.01% CCDF

Characteristic	Symbol	Min	Typ	Max	Unit
Input Return Loss	IRL	—	-16	-10	dB
Gain	G_{ps}	26.5	28	—	dB
Drain Efficiency	η_D	9	10.5	—	%
Intermodulation Distortion, 2-channel WCDMA	IMD	-43	-47	—	dBc

All published data at $T_{CASE} = 25^\circ\text{C}$ unless otherwise indicated

ESD: Electrostatic discharge sensitive device—observe handling precautions!

RF Characteristics

Small-signal CW Measurements (not subject to production test—verified by design/characterization in Infineon test fixture)
 $V_{DD} = 28\text{ V}$, $I_{DQ1} = 200\text{ mA}$, $I_{DQ2} = 450\text{ mA}$, $P_{OUT} = 1\text{ W}$, $f = 2140\text{ MHz}$

Characteristic	Conditions	Symbol	Min	Typ	Max	Unit
Gain Flatness	1 W / 30 MHz	ΔG	—	0.10	0.5	dB
Phase Linearity		—	-1	+0.6	+1	°/60 MHz
Group Delay	$f = 2140\text{ MHz}$	td	—	2.16	—	ns

DC Characteristics

Stage 1 Characteristics	Conditions	Symbol	Min	Typ	Max	Unit
Drain Leakage Current	$V_{DS} = 28\text{ V}$, $V_{GS} = 0\text{ V}$	I_{DSS}	—	—	1.0	μA
	$V_{DS} = 63\text{ V}$, $V_{GS} = 0\text{ V}$	I_{DSS}	—	—	10.0	μA
Gate Leakage Current	$V_{GS} = 10\text{ V}$, $V_{DS} = 0\text{ V}$	I_{GSS}	—	—	1.0	μA
On-state Resistance	$V_{GS} = 10\text{ V}$, $V_{DS} = 0.1\text{ V}$	$R_{DS(on)}$	—	1.1	—	Ω
Operating Gate Voltage	$V_{DS} = 28\text{ V}$, $I_{DQ1} = 200\text{ mA}$,	V_{GS}	2.0	2.5	3.0	V

Stage 2 Characteristics	Conditions	Symbol	Min	Typ	Max	Unit
Drain-source Breakdown Voltage	$V_{GS} = 0\text{ V}$, $I_{DS} = 10\text{ mA}$	$V_{(BR)DSS}$	65	—	—	V
Drain Leakage Current	$V_{DS} = 28\text{ V}$, $V_{GS} = 0\text{ V}$	I_{DSS}	—	—	1.0	μA
	$V_{DS} = 63\text{ V}$, $V_{GS} = 0\text{ V}$	I_{DSS}	—	—	10.0	μA
Gate Leakage Current	$V_{GS} = 10\text{ V}$, $V_{DS} = 0\text{ V}$	I_{GSS}	—	—	1.0	μA
On-state Resistance	$V_{GS} = 10\text{ V}$, $V_{DS} = 0.1\text{ V}$	$R_{DS(on)}$	—	0.16	—	Ω
Operating Gate Voltage	$V_{DS} = 28\text{ V}$, $I_{DQ2} = 450\text{ mA}$	V_{GS}	2.0	2.5	3.0	V

Maximum Ratings

Parameter	Symbol	Value	Unit
Drain-Source Voltage	V_{DSS}	65	V
Gate-Source Voltage	V_{GS}	-0.5 to +12	V
Junction Temperature	T_J	200	°C
Input Power	P_{IN}	25	dBm
Storage Temperature Range	T_{STG}	-40 to +150	°C
Thermal Resistance ($T_{CASE} = 70^{\circ}C$)	Stage 1	$R_{\theta JC}$	3.5 °C/W
	Stage 2	$R_{\theta JC}$	1.3 °C/W

Ordering Information

Type and Version	Package Outline	Package Description	Shipping
PTMA210452EL V1	H-33265-8	Thermally-enhanced slotted flange	Tray
PTMA210452EL V1 R250	H-33265-8	Thermally-enhanced slotted flange	Tape & Reel
PTMA210452FL V1	H-34265-8	Thermally-enhanced earless flange	Tray
PTMA210452FL V1 R250	H-34265-8	Thermally-enhanced earless flange	Tape & Reel

Typical Performance (data taken in a production test fixture)

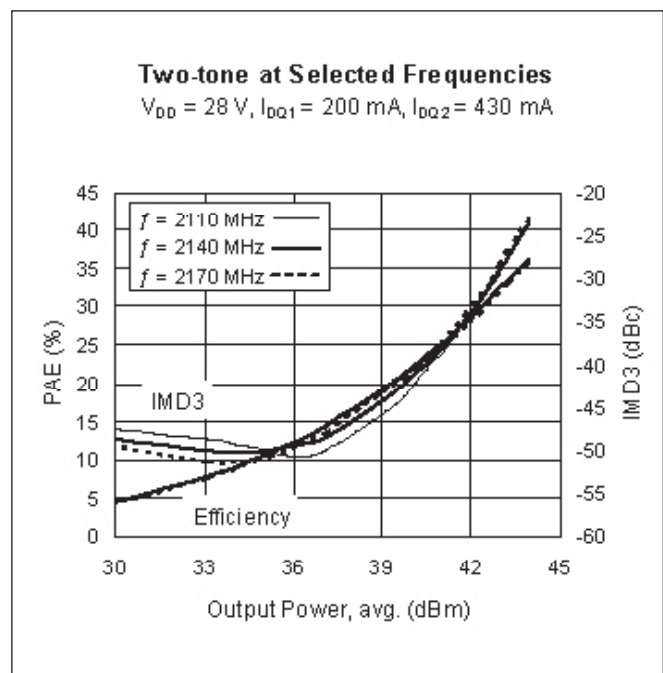
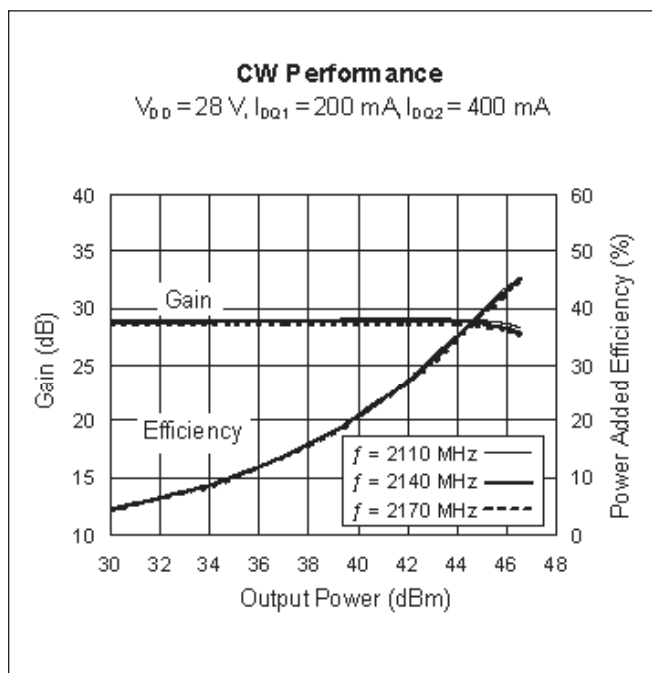

Typical Performance (cont.)

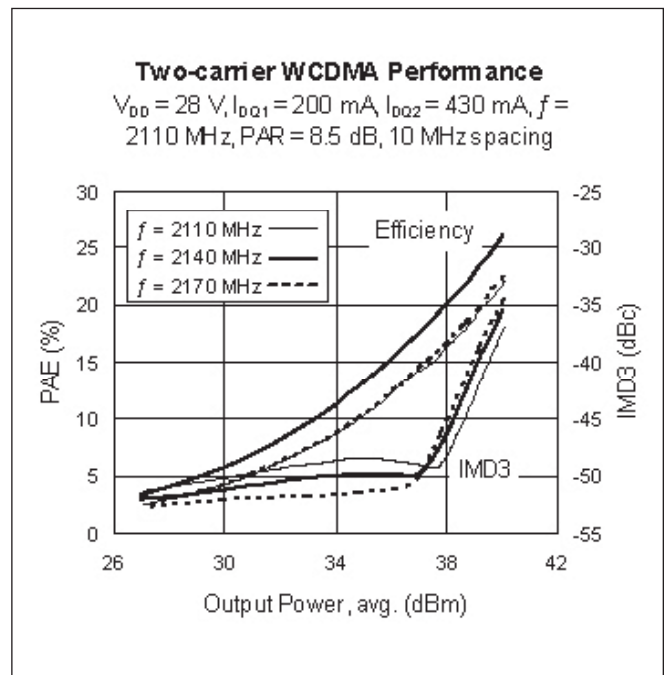
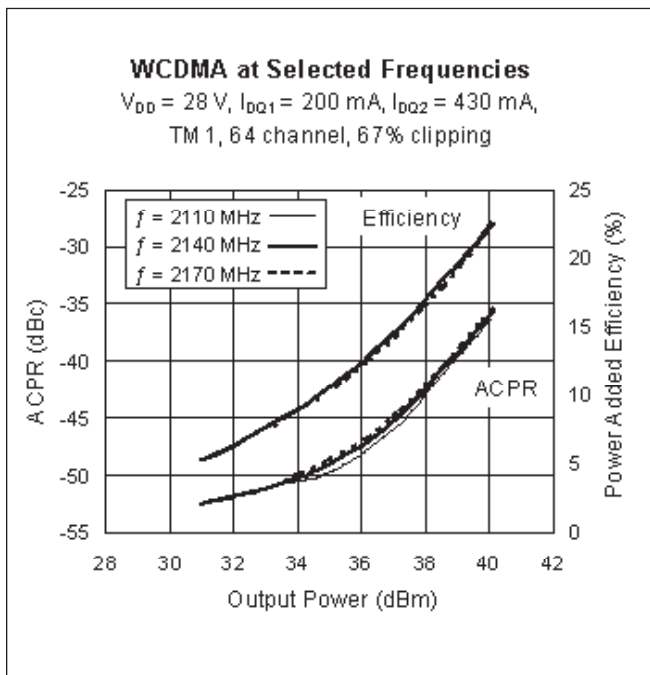
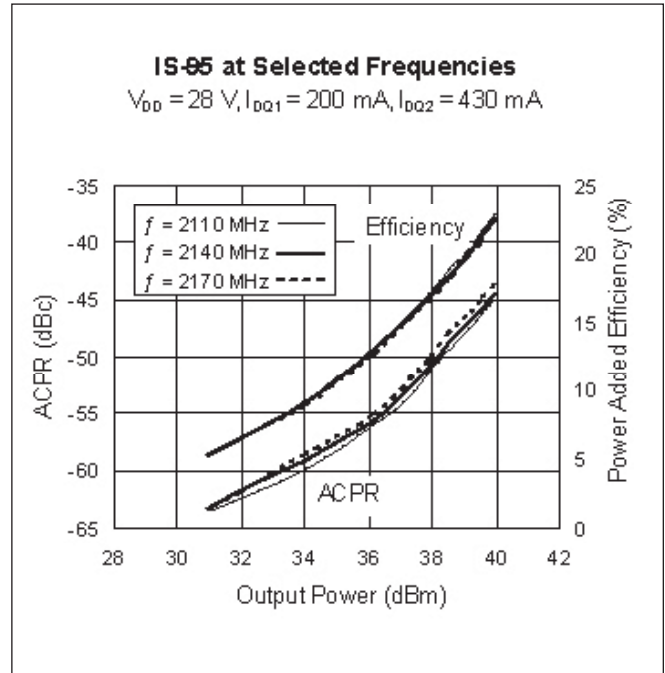
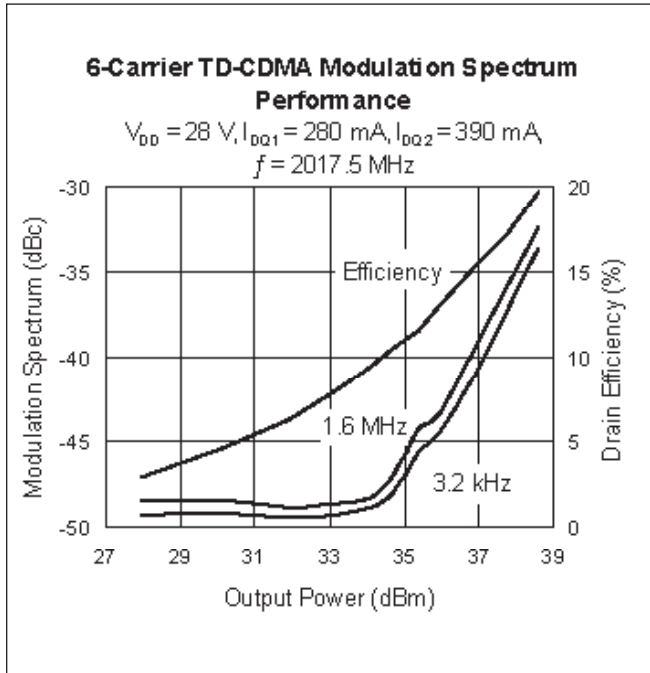

Typical Performance (cont.)

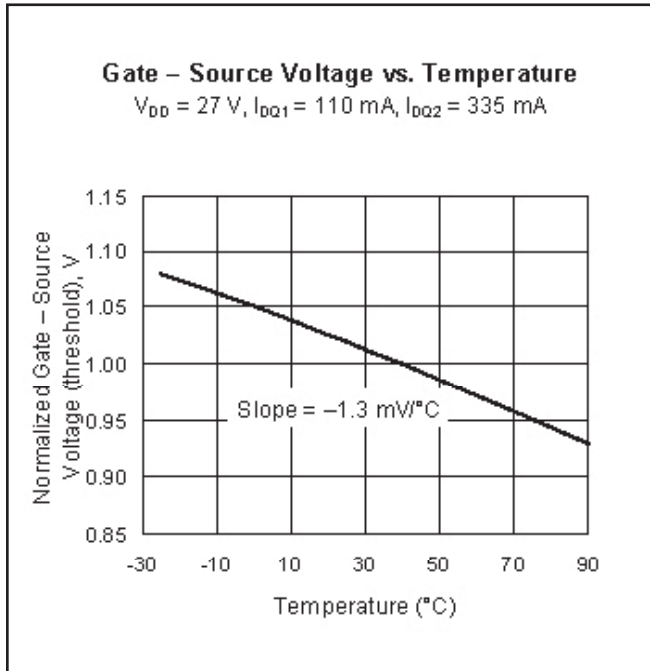

Broadband Circuit Impedance

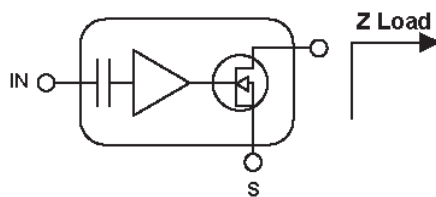

Frequency MHz	Z Source Ω		Z Load Ω	
	R	jX	R	jX
1900	25.2	20.4	8.8	12.2
2110	26.1	27.8	6.1	16.5
2140	26.2	28.9	5.9	17.1
2170	26.5	30.3	5.6	17.8
2200	26.6	31.6	5.2	18.6

Reference Circuit — for evaluation only

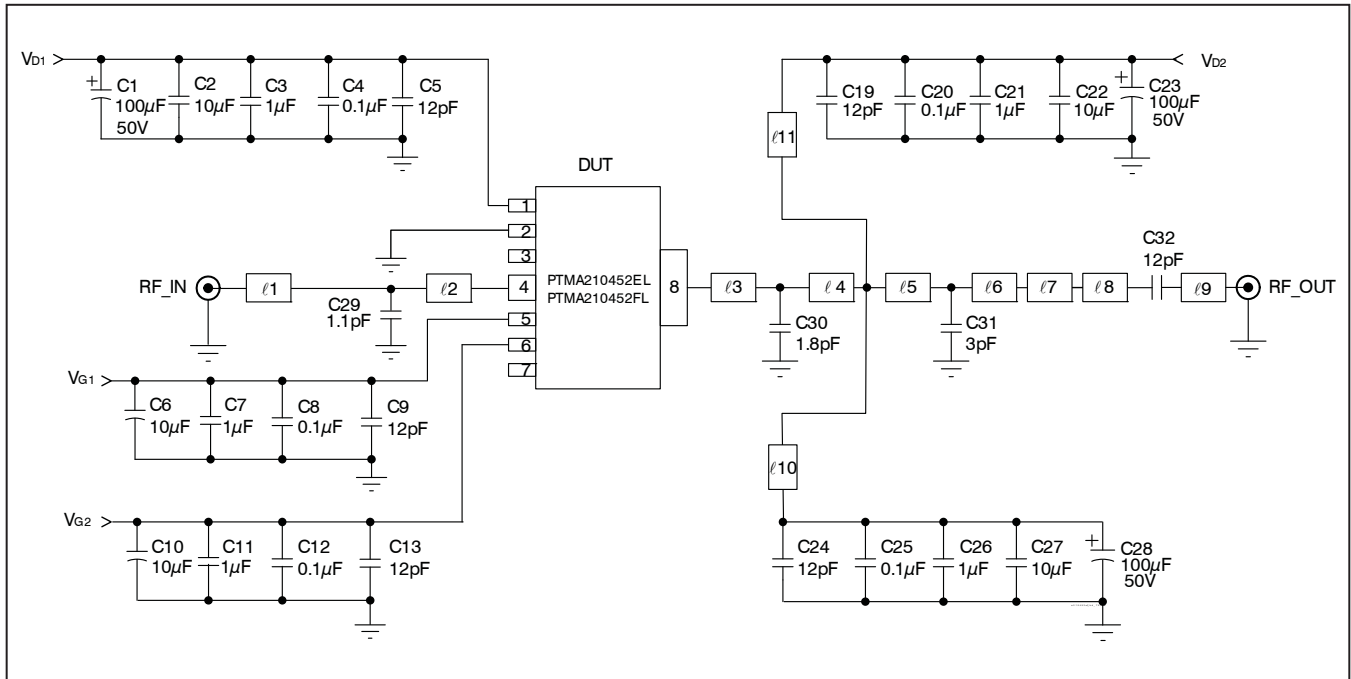

Reference circuit schematic for $f = 2140$ MHz

Circuit Assembly Information

DUT	PTMA210452EL or PTMA210452FL	RF LDMOS Integrated Power Amplifier ICs
Test Fixture Part No.	LTN/PTMA210452	
PCB	Rogers RO4350	$\epsilon_r = 3.48$, 0.76 mm [.030"] thick, 1 oz. copper
Find Gerber files for this test fixture on the Infineon Web site at http://www.infineon.com/rfpower		

Microstrip	Electrical Characteristics at 2140 MHz	Dimensions: L x W (mm)	Dimensions: L x W (in.)
l1	0.129 λ , 49.7 Ω	11.00 x 1.70	0.433 x 0.067
l2	0.114 λ , 49.7 Ω	9.68 x 1.70	0.381 x 0.067
l3	0.040 λ , 10.4 Ω	3.10 x 13.00	0.122 x 0.512
l4	0.013 λ , 10.4 Ω	1.02 x 13.00	0.039 x 0.512
l5	0.024 λ , 34.1 Ω	2.01 x 3.00	0.079 x 0.118
l6	0.066 λ , 34.1 Ω	5.46 x 3.00	0.215 x 0.118
l7	0.162 λ , 43.4 Ω	13.67 x 2.11	0.538 x 0.083
l8	0.004 λ , 49.7 Ω	0.38 x 1.70	0.015 x 0.067
l9	0.050 λ , 49.7 Ω	4.24 x 1.70	0.167 x 0.067
l10, l11	0.128 λ , 61.2 Ω	11.00 x 1.19	0.433 x 0.047

Reference Circuit (cont.)

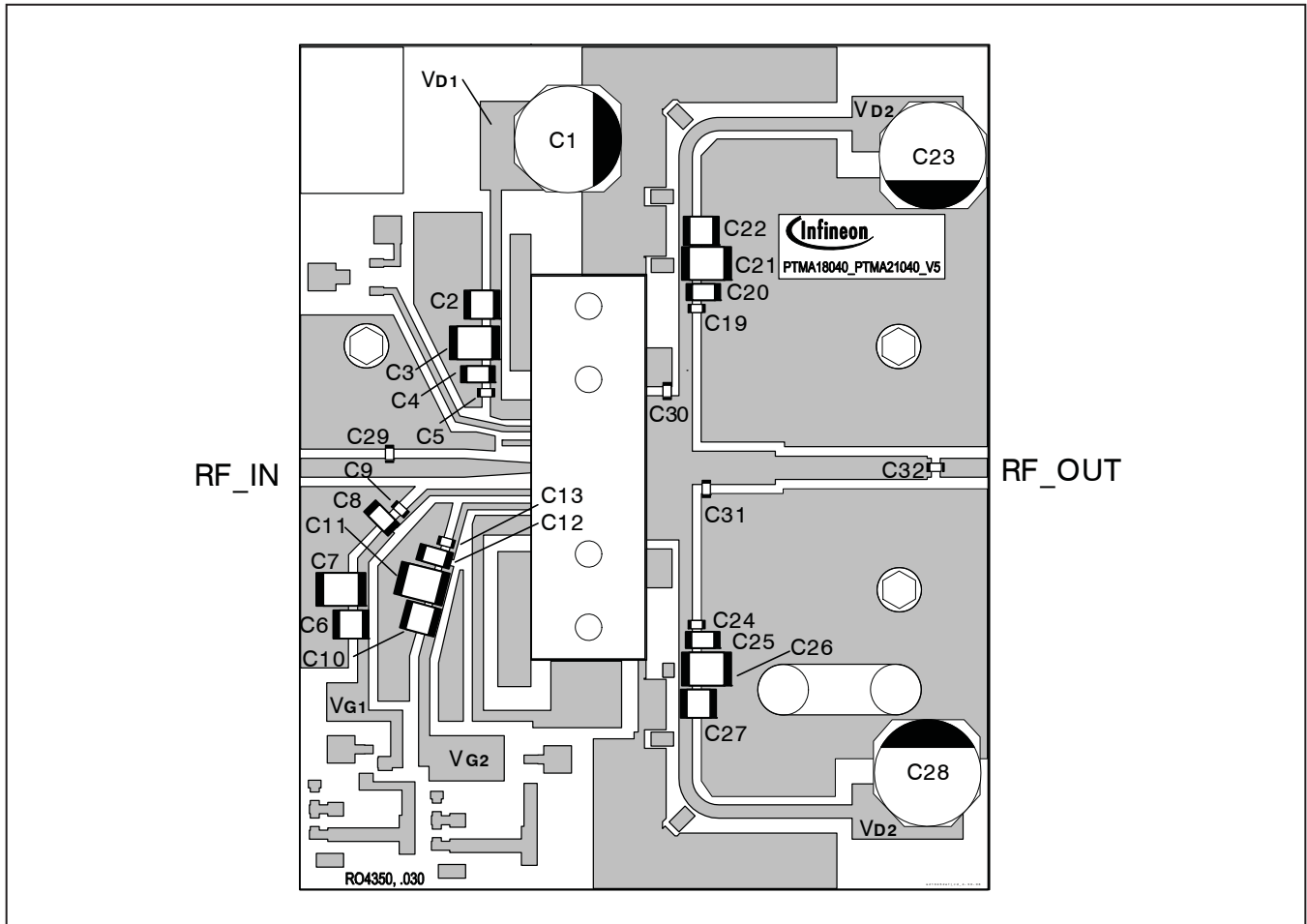

Reference circuit assembly diagram (not to scale)

Circuit Assembly Table

Component	Description	Suggested Supplier	P/N or Comment
C1, C23, C28	Electrolytic capacitor 100 µF, 50 V	Digi-Key	PCE3718CT-ND
C2, C6, C10, C22, C27	Ceramic capacitor 10 µF	Murata	GRM422Y5V106Z050AL
C3, C7, C11, C21, C26	Ceramic capacitor 1 µF	Digi-Key	445-1411-2-ND
C4, C8, C12, C20, C25	Capacitor, 0.1 µF	Digi-Key	399-1267-2-ND
C5, C9, C13, C19, C24, C32	Ceramic capacitor 12 pF	ATC	600S120JT
C29	Ceramic capacitor 1.1 pF	ATC	600S1R1BT
C30	Ceramic capacitor 1.8 pF	ATC	600S1R8BT
C31	Ceramic capacitor 3 pF	ATC	600S3R0BT
Not used	C14, C15, C16, C17, C18		

Package Specifications

Package H-33265-8 Outline

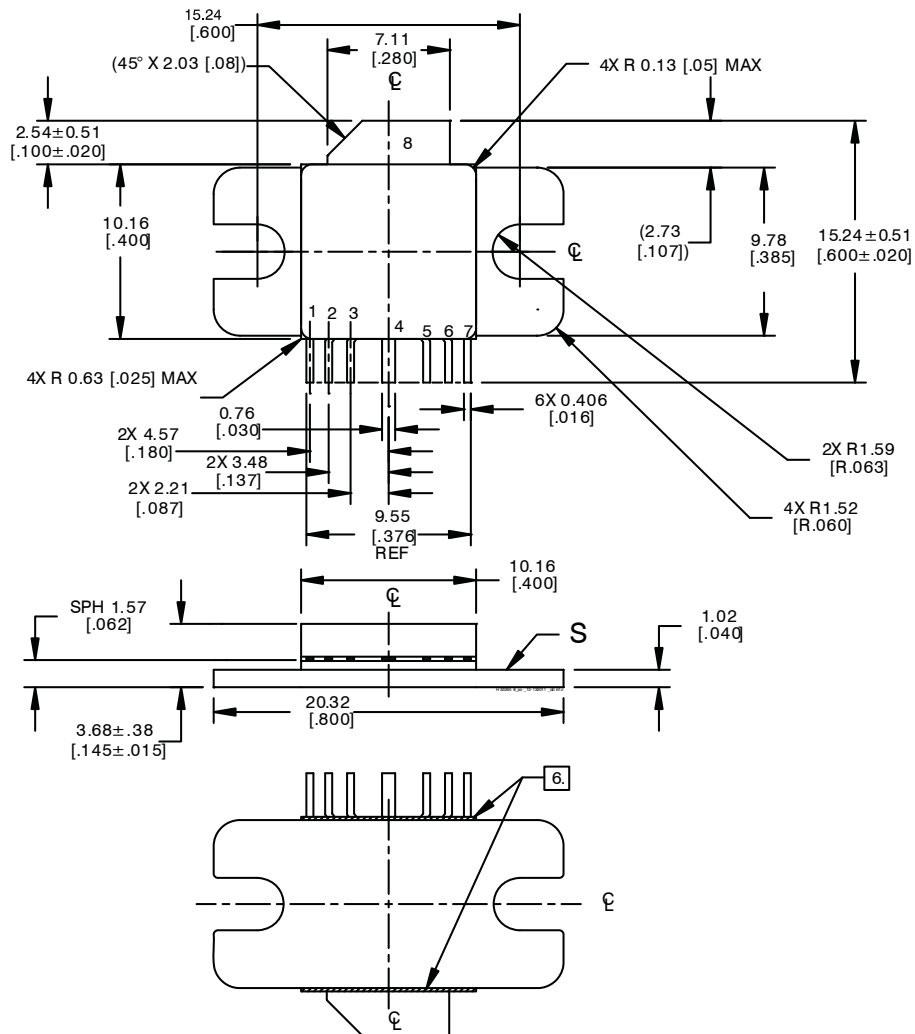

Diagram Notes—unless otherwise specified:

1. Interpret dimensions and tolerances per ASME Y14.5M-1994.
2. Pins: see page 10 for complete list and pinout diagram.
3. Lead thickness: 0.127 ± 0.025 [0.005 ± 0.001].
4. Gold plating less than 0.25 micron [10 microinch].
5. All tolerances ± 0.127 [0.005] unless specified otherwise.
6. Exposed metal plane on bottom of ceramic insulator.
7. Primary dimensions are inches, alternate dimensions are mm.

Package Specifications (cont.)

Package H-34265-8 Outline

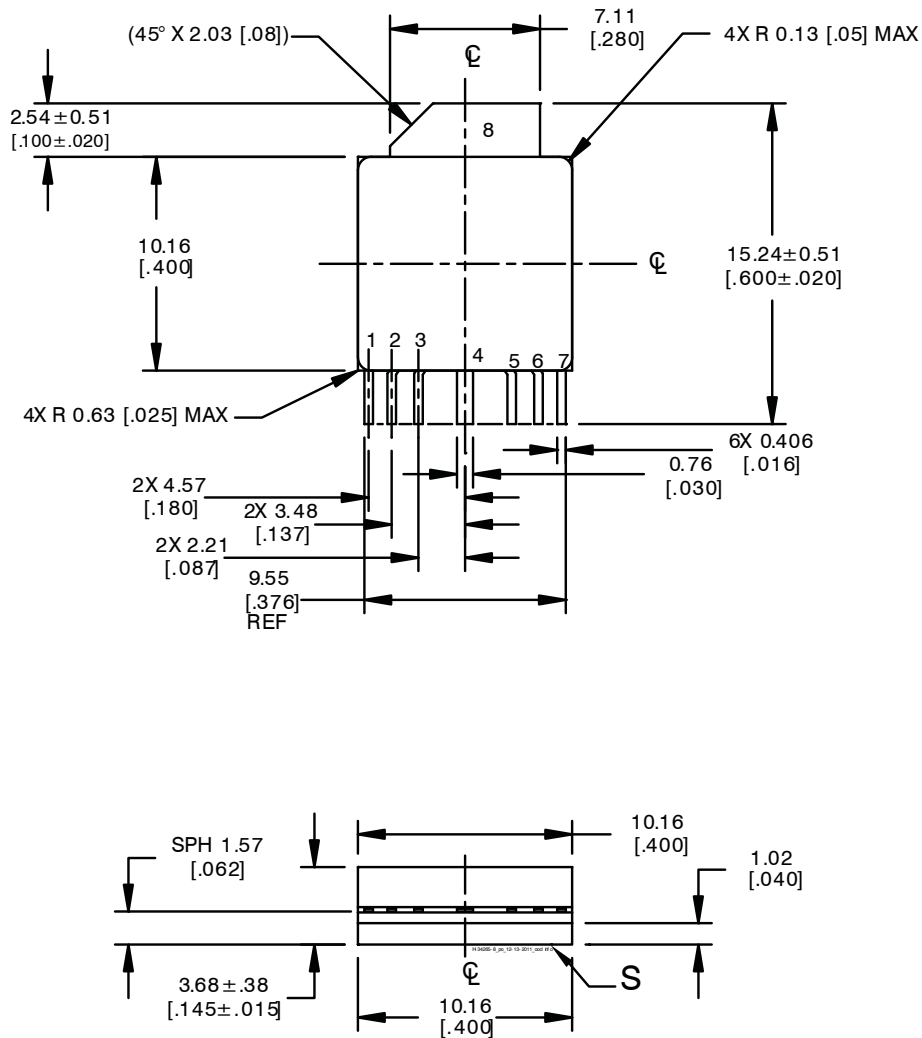
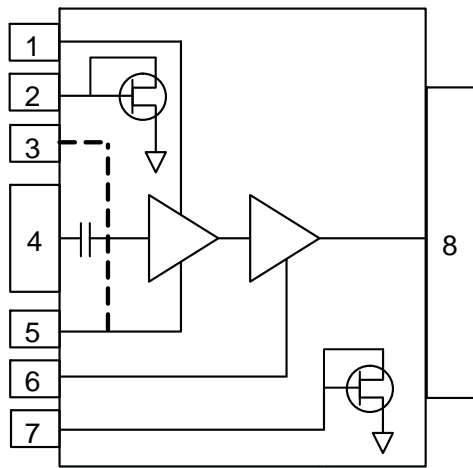

Diagram Notes—unless otherwise specified:

1. Interpret dimensions and tolerances per ASME Y14.5M-1994.
2. Pins: see page 10 for complete list and pinout diagram.
3. Lead thickness: 0.127 ± 0.025 [0.005 ± 0.001].
4. Gold plating less than 0.25 micron [10 microinch].
5. All tolerances ± 0.127 [0.005] unless specified otherwise.
6. Primary dimensions are inches, alternate dimensions are mm.

Package Specifications (cont.)

Package H-3X265-8 Pinout



Pin #	Function
S (Flange)	Source
1	V _{D1}
2	V _{G1} thermal FET
3	V _{G1}
4	RF In
5	V _{G1}
6	V _{G2}
7	V _{G2} thermal FET
8	RF Out

Find the latest and most complete information about products and packaging at the Infineon Internet page
<http://www.infineon.com/rfpower>

Previous Version: 2009-09-01, Data Sheet

Page	Subjects (major changes since last revision)
	Revised DC Characteristics table for clarity.

We Listen to Your Comments

Any information within this document that you feel is wrong, unclear or missing at all?
 Your feedback will help us to continuously improve the quality of this document.
 Please send your proposal (including a reference to this document) to:

highpowerRF@infineon.com

To request other information, contact us at:
 +1 877 465 3667 (1-877-GO-LDMOS) USA
 or +1 408 776 0600 International

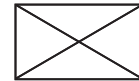

Edition 2011-11-10

Published by
Infineon Technologies AG
81726 Munich, Germany

© 2007 Infineon Technologies AG
All Rights Reserved.

Legal Disclaimer

The information given in this document shall in no event be regarded as a guarantee of conditions or characteristics. With respect to any examples or hints given herein, any typical values stated herein and/or any information regarding the application of the device, Infineon Technologies hereby disclaims any and all warranties and liabilities of any kind, including without limitation, warranties of non-infringement of intellectual property rights of any third party.

Information

For further information on technology, delivery terms and conditions and prices, please contact the nearest Infineon Technologies Office (www.infineon.com/rfpower).

Warnings

Due to technical requirements, components may contain dangerous substances. For information on the types in question, please contact the nearest Infineon Technologies Office.

Infineon Technologies components may be used in life-support devices or systems only with the express written approval of Infineon Technologies, if a failure of such components can reasonably be expected to cause the failure of that life-support device or system or to affect the safety or effectiveness of that device or system. Life support devices or systems are intended to be implanted in the human body or to support and/or maintain and sustain and/or protect human life. If they fail, it is reasonable to assume that the health of the user or other persons may be endangered.