



2360

# Radio Test Report

## Cambridge Communication Systems Ltd

### Metnet 60G

47 CFR Part 15.255 Effective Date 1st October 2018  
DXX: Part 15 Low Power Communication Device Transmitter

Test Date: 28th November 2018 to 13th February 2019  
Report Number: 02-9927-4-19 Issue 03  
Supersedes Report Number: 02-9927-4-19 Issue 02

**R.N. Electronics Ltd.**  
Arnolds Court  
Arnolds Farm Lane  
Mountnessing  
Essex  
CM13 1UT  
U.K.

[www.RNelectronics.com](http://www.RNelectronics.com)

Telephone: +44 (0) 1277 352219  
Email: [sales@RNelectronics.com](mailto:sales@RNelectronics.com)

This report is not to be reproduced by any means except in full and in any case not without the written approval of R.N. Electronics Ltd.



Arnolds Court, Arnolds Farm Lane, Mountnessing, Brentwood Essex, CM13 1UT

### Certificate of Test 9927-4

The equipment noted below has been fully tested by R.N. Electronics Limited and, where appropriate, conforms to the relevant subpart of 47 CFR Part 15C. This is a certificate of test only and should not be confused with an equipment authorisation. Other standards may also apply.

Equipment:	Metnet 60G
Model Number:	Metnet 60G
Unique Serial Number:	128 (TX radiated spurious 30 MHz-1 GHz only) 25 (all other tests)
Applicant:	Cambridge Communication Systems Ltd Victory House, Chivers Way Histon, Cambridge CB24 9ZR
Full measurement results are detailed in Report Number:	02-9927-4-19 Issue 03
Test Standards:	47 CFR Part 15.255 Effective Date 1 <sup>st</sup> October 2018 DXX: Part 15 Low Power communication device transmitter

**NOTE:**

Certain tests were not performed based upon manufacturer's declarations. Certain other requirements are subject to manufacturer declaration only and have not been tested/verified. For details refer to section 3 of this report.

**DEVIATIONS:**

No deviations have been applied.

This certificate relates only to the unit tested as identified by a unique serial number and in the condition at the time it was tested. It does not relate to any other similar equipment and performance of the product before or after the test cannot be guaranteed. Whilst every effort is made to assure quality of testing, type tests are not exhaustive and although no non-conformances may be found, this doesn't exclude the possibility of unit not meeting the intentions of the standard or the requirements of the Federal Regulations, particularly under different conditions to those during testing. Any compliance statements are made reliant on (a) the application of the product and use of the assigned band being acceptable to the FCC and (b) the modes of operation as instructed to us by the Customer based on their specific knowledge of the application and functionality of the EUT. Statements of compliance, where measurements were made, do not include the measurement uncertainty. The measurement uncertainty, where stated, is the expanded uncertainty based on a standard uncertainty multiplied by a coverage factor of k=2, providing a level of confidence of approximately 95%.

Date Of Test: 28th November 2018 to 13th February 2019

Test Engineer:

Approved By:  
Radio Approvals Manager

Customer  
Representative:



## 1 Contents

1	Contents .....	3
2	Equipment under test (EUT) .....	4
2.1	Equipment specification .....	4
2.2	Configurations for testing .....	4
2.3	Functional description .....	5
2.4	Modes of operation.....	5
2.5	Emissions configuration .....	7
3	Summary of test results .....	9
4	Specifications .....	10
4.1	Relevant standards .....	10
4.2	Deviations .....	10
4.3	Tests at extremes of temperature & voltage .....	10
4.4	Test fixtures .....	10
5	Tests, methods and results .....	11
5.1	AC power line conducted emissions .....	11
5.2	Radiated emissions 9 - 150 kHz.....	13
5.3	Radiated emissions 150 kHz - 30 MHz .....	13
5.4	Radiated emissions 30 MHz -1 GHz .....	14
5.5	Radiated emissions above 1 GHz.....	16
5.6	Frequency stability .....	20
5.7	Peak & Average EIRP .....	22
5.8	Peak Conducted Power.....	25
5.9	6dB Occupied bandwidth .....	26
6	Plots/Graphical results .....	31
6.1	AC power line conducted emissions .....	31
6.2	Radiated emissions 30 MHz -1 GHz .....	33
6.3	Radiated emissions above 1 GHz .....	35
6.4	6dB Occupied bandwidth .....	50
7	Explanatory Notes.....	76
7.1	Explanation of Table of Signals Measured.....	76
7.2	Explanation of limit line calculations for radiated measurements .....	76
8	Photographs .....	78
8.1	EUT Front View .....	78
8.2	EUT Reverse Angle.....	78
8.3	EUT Left side View.....	79
8.4	EUT Right side View .....	79
8.5	EUT Antenna .....	80
8.6	EUT Display & Controls.....	81
8.7	EUT Internal photos .....	82
8.8	EUT ID Label .....	83
8.9	AC power line conducted emissions .....	84
8.10	Radiated emissions 30 MHz -1 GHz .....	86
8.11	Radiated emissions above 1 GHz .....	87
8.12	Radiated emission diagrams .....	92
8.13	AC powerline conducted emission diagram .....	93
9	Test equipment calibration list .....	94
10	Auxiliary and peripheral equipment.....	95
10.1	Customer supplied equipment.....	95
10.2	RN Electronics supplied equipment .....	95
11	Condition of the equipment tested .....	96
11.1	Modifications before test .....	96
11.2	Modifications during test.....	96
12	Description of test sites .....	97
13	Abbreviations and units.....	98

## 2 Equipment under test (EUT)

### 2.1 Equipment specification

Applicant	Cambridge Communication Systems Ltd Victory House Chivers Way Histon Cambridge CB24 9ZR	
Manufacturer of EUT	Jabil Malaysia	
Full Name of EUT	Metnet 60G	
Model Number of EUT	Metnet 60G	
Serial Number of EUT	128 (TX radiated spurious 30 MHz-1 GHz only) 25 (All other tests)	
Date Received	27th November 2018	
Date of Test:	28th November 2018 to 13th February 2019	
Purpose of Test	To demonstrate design compliance to the relevant rules of Chapter 47 of the Code of Federal Regulations.	
Date Report Issued	25th April 2019	
Main Function	60 GHz mmwave backhaul.	
Information Specification	Height	257 mm
	Width	137 mm
	Depth	100 mm
	Weight	3.3 kg
	Voltage	100-240V AC
	Current	1.2 A

### 2.2 Configurations for testing

General Parameters	
EUT Normal use position	Mounted on a lamppost
Choice of model(s) for type tests	Prototype sample
Antenna details	20 dBi phased array beamforming
Antenna port	No
Baseband Data port (yes/no)?	No
Highest Signal generated in EUT	64.8 GHz
Lowest Signal generated in EUT	45 MHz
Hardware Version	Metnet60G V1
Software Version	Archimedes V 0.3. (Archimedes V 0.31 for radiated emissions above 1 GHz)
Firmware Version	Not applicable
Type of Equipment	mmWave multipoint to multipoint
Technology Type	802.11 ad
Geo-location (yes/no)	Yes
TX Parameters	
Alignment range – transmitter	57-66 GHz
EUT Declared Modulation Parameters	BPSK, QPSK, 16QAM
EUT Declared Power level	+40 dBm EIRP

EUT Declared Signal Bandwidths	2.16 GHz
EUT Declared Channel Spacing's	2.16 GHz
EUT Declared Duty Cycle	Not declared
Unmodulated carrier available?	Yes
Declared frequency stability	+/-2.5 ppm/20 years
<b>RX Parameters</b>	
Alignment range – receiver	57-66 GHz
EUT Declared RX Signal Bandwidth	2.16 GHz
Receiver Signal Level (RSL)	Not declared
Method of Monitoring Receiver BER	PER
<b>FCC Parameters</b>	
FCC Transmitter Class	DXC: Part 15 Low Power Communication Device Transmitter

## 2.3 Functional description

Multipoint to multipoint mmwave backhaul. The equipment contains four 60 GHz transceivers each connected to its own steerable multi element antenna array.

## 2.4 Modes of operation

Mode Reference	Description	Used for testing
TX1	58.32 GHz CW (99.687 MHz tone)	Yes
TX2	60.48GHz CW (99.687 MHz tone)	Yes
TX3	62.64 GHz CW (99.687 MHz tone)	Yes
TX4	64.80 GHz CW (99.687 MHz tone)	Yes
TX5	58.32GHz 40dBm MCS0	Yes
TX6	58.32GHz 40dBm MCS1	Yes
TX7	58.32GHz 40dBm MCS2	Yes
TX8	58.32GHz 40dBm MCS3	Yes
TX9	58.32GHz 40dBm MCS4	Yes
TX10	58.32GHz 40dBm MCS5	Yes
TX11	58.32GHz 40dBm MCS6	Yes
TX12	58.32GHz 40dBm MCS7	Yes
TX13	58.32GHz 40dBm MCS8	Yes
TX14	58.32GHz 40dBm MCS9	Yes
TX15	58.32GHz 40dBm MCS10	Yes
TX16	58.32GHz 40dBm MCS11	Yes
TX17	58.32GHz 40dBm MCS12	Yes
TX18	60.48GHz 40dBm MCS0	Yes
TX19	60.48GHz 40dBm MCS1	Yes
TX20	60.48GHz 40dBm MCS2	Yes
TX21	60.48GHz 40dBm MCS3	Yes
TX22	60.48GHz 40dBm MCS4	Yes
TX23	60.48GHz 40dBm MCS5	Yes
TX24	60.48GHz 40dBm MCS6	Yes
TX25	60.48GHz 40dBm MCS7	Yes
TX26	60.48GHz 40dBm MCS8	Yes
TX27	60.48GHz 40dBm MCS9	Yes
TX28	60.48GHz 40dBm MCS10	Yes
TX29	60.48GHz 40dBm MCS11	Yes
TX30	60.48GHz 40dBm MCS12	Yes
TX31	62.64GHz 40dBm MCS0	Yes

TX32	62.64GHz 40dBm MCS1	Yes
TX33	62.64GHz 40dBm MCS2	Yes
TX34	62.64GHz 40dBm MCS3	Yes
TX35	62.64GHz 40dBm MCS4	Yes
TX36	62.64GHz 40dBm MCS5	Yes
TX37	62.64GHz 40dBm MCS6	Yes
TX38	62.64GHz 40dBm MCS7	Yes
TX39	62.64GHz 40dBm MCS8	Yes
TX40	62.64GHz 40dBm MCS9	Yes
TX41	62.64GHz 40dBm MCS10	Yes
TX42	62.64GHz 40dBm MCS11	Yes
TX43	62.64GHz 40dBm MCS12	Yes
TX44	64.8GHz 40dBm MCS0	Yes
TX45	64.8GHz 40dBm MCS1	Yes
TX46	64.8GHz 40dBm MCS2	Yes
TX47	64.8GHz 40dBm MCS3	Yes
TX48	64.8GHz 40dBm MCS4	Yes
TX49	64.8GHz 40dBm MCS5	Yes
TX50	64.8GHz 40dBm MCS6	Yes
TX51	64.8GHz 40dBm MCS7	Yes
TX52	64.8GHz 40dBm MCS8	Yes
TX53	64.8GHz 40dBm MCS9	Yes
TX54	64.8GHz 40dBm MCS10	Yes
TX55	64.8GHz 40dBm MCS11	Yes
TX56	64.8GHz 40dBm MCS12	Yes

Note: The EUT has 4 identical radios and test modes above are available for each radio.

## 2.5 Emissions configuration

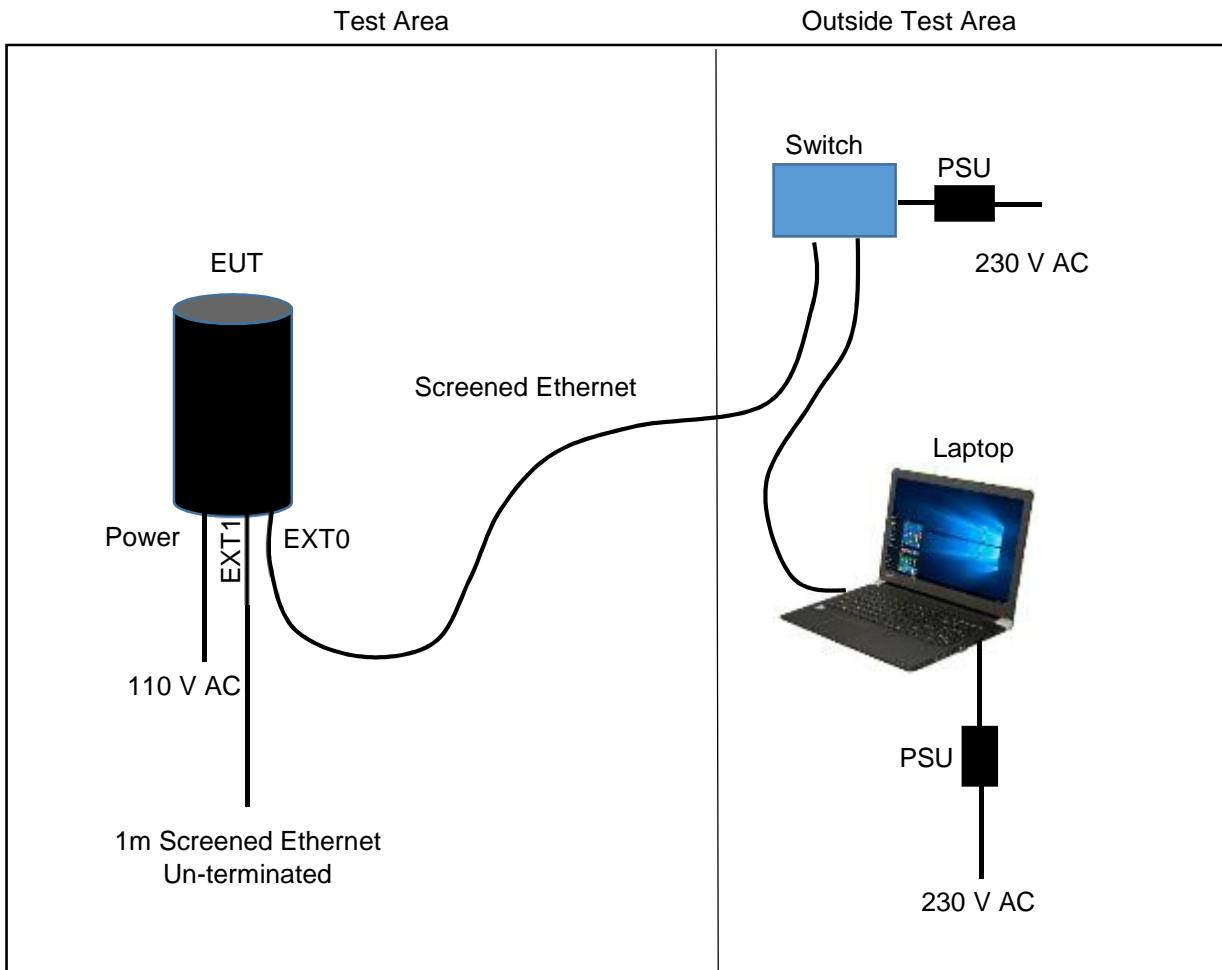

The unit was powered from 110 V AC mains. The unit was configured with engineering menus via a terminal program to allow permanent transmit modes of the device on the each of 4 radios, and on the channels and modulation schemes as stated within section 2.4 of this report. The applicant declares that each radio operates on a different channel and that they can transmit at the same time. In addition, each radio allows circular beam steering as defined in ANSI C63.10 section 13. The beam value is settable between 0 and 64, with 0 being omnidirectional and 1 to 63 being a sector angle. The applicant declares that it is possible for beam overlap from adjacent radios (but each radio is on a different channel). RN Electronics performed initial investigations in 0.5° steps on each of the radios through a 360° EUT rotation for all beam settings. The -3 dB beamwidth was found to be approximately  $\pm 4^\circ$  and is steerable over roughly 95° thereby providing near 360° coverage with all four radios. It was found that individual antenna beamwidth increased slightly on antenna beams at each end of the antenna arrays. From this information it was possible to determine the effect of having adjacent radios with beam overlap and where maximum EIRP would occur.

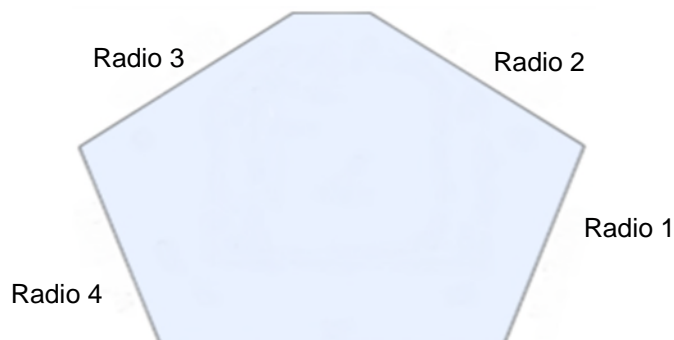

View from above showing arrangement of radios

Beam overlap between radio 3 (Beam 57) and radio 4 (Beam 7) proved to be the highest summed power out of the 4 radios where any beam overlapping occurred– but this summed level was not higher than the power measured out of a single antenna (beam) setting in the middle of the array (see section 5.7 within this report for results).

The transmit mode was declared as 250  $\mu$ s off time with on times varying from 300  $\mu$ s for MCS0 to 7.5  $\mu$ s for MCS12 with modulation and the power settings for each channel were as stated below:-

Channel 1 = 58.32 GHz, power level +40 dBm (all modulation schemes)

Channel 2 = 60.48 GHz, power level +40 dBm (all modulation schemes)

Channel 3 = 62.64 GHz, power level +40 dBm (all modulation schemes)

Channel 4 = 64.8 GHz, power level +40 dBm (all modulation schemes)

Modulation schemes available were DBPSK (MCS0), BPSK (MCS1 to MCS5), QPSK (MCS6 to MCS9) and 16QAM (MCS10 to MCS12).

### 2.5.1 Signal leads

Port Name	Cable Type	Connected
Power	Mains	Yes
EXT0	Ethernet shielded	Yes
EXT1	Ethernet shielded	Yes



### 3 Summary of test results

The Metnet 60G was tested for compliance to the following standard(s) :

47 CFR Part 15.255 Effective Date 1st October 2018  
DXX: Part 15 Low Power Communication Device Transmitter

Any compliance statements are made reliant on (a) the application of the product and use of the assigned band being acceptable to the FCC and (b) the modes of operation as instructed to us by the Customer based on their specific knowledge of the application and functionality of the EUT. Whilst every effort is made to assure quality of testing, type tests are not exhaustive and although no non-conformances may be found, this doesn't exclude the possibility of equipment not meeting the intentions of the standard or the essential requirements of the directive, particularly under different conditions to those during testing. Statements of compliance, where measurements were made, do not include the measurement uncertainty. The measurement uncertainty, where stated, is the expanded uncertainty based on a standard uncertainty multiplied by a coverage factor of k=2, providing a level of confidence of approximately 95%.

Title	References	Results
<b>Transmitter Tests</b>		
1. AC power line conducted emissions	47 CFR Part 15C Part 15.207	PASSED
2. Radiated emissions 9 - 150 kHz	47 CFR Part 15C Part 15.209	NOT APPLICABLE <sup>1</sup>
3. Radiated emissions 150 kHz - 30 MHz	47 CFR Part 15C Part 15.209	NOT APPLICABLE <sup>1</sup>
4. Radiated emissions 30 MHz -1 GHz	47 CFR Part 15C Part 15.255(d)(2)	PASSED
5. Radiated emissions above 1 GHz	47 CFR Part 15C Part 15.255(d)(2)/(3)/(4)	PASSED <sup>3</sup>
6. Frequency stability	47 CFR Part 15C Part 15.255(f)	PASSED
7. Peak & Average EIRP	47 CFR Part 15C Part 15.255(c)(1)(i)/(ii)	PASSED
8. Peak Conducted Power	47 CFR Part 15C Part 15.255(c)(3)/(4)	NOT APPLICABLE <sup>2</sup>
9. 6dB Occupied bandwidth	47 CFR Part 15C Part 15.255(e)1	PASSED

<sup>1</sup> Lowest frequency generated within the unit is declared as 45MHz

<sup>2</sup> EUT does not have a conducted RF port.

<sup>3</sup> Spectrum investigated started at a frequency of 30MHz up to a frequency of 200GHz. The highest channel/ signal generated in the equipment is 64.8GHz.

## 4 Specifications

The tests were performed and operated in accordance with R.N. Electronics Ltd procedures and the relevant standards listed below.

### 4.1 Relevant standards

Ref.	Standard Number	Version	Description
4.1.1	47 CFR Part 15C	2018	Federal Communications Commission PART 15 – RADIO FREQUENCY DEVICES
4.1.2	ANSI C63.10	2013	American National Standard of Procedures for Compliance Testing of Unlicensed Wireless Devices
4.1.3	ANSI C63.4	2014	American National Standard for Methods of Measurement of Radio-Noise Emissions from Low-Voltage Electrical and Electronic Equipment in the Range of 9 kHz to 40 GHz

### 4.2 Deviations

No deviations were applied.

### 4.3 Tests at extremes of temperature & voltage

The following test conditions were used to simulate testing at nominal or extremes.

Temperature Test Conditions		Voltage Test Conditions	
T nominal	20 °C	V nominal	110V AC
T minimum	-20 °C	V minimum	93.5V AC
T maximum	50 °C	V maximum	126.5V AC

Extremes of voltage are based on nominal +/-15%.

Extremes of temperature are based upon manufacturer's declaration.

The ambient test conditions of humidity and pressure in the laboratory were as specified in each specific test section within this report

### 4.4 Test fixtures

In order to measure RF parameters at temperature extremes, the EUT was tested in a temperature controlled chamber as follows:

A test fixture was used for testing.

## 5 Tests, methods and results

### 5.1 AC power line conducted emissions

#### 5.1.1 Test methods

Test Requirements: 47 CFR Part 15C Part 15.207 [Reference 4.1.1 of this report]  
 Test Method: ANSI C63.10 Clause 6.2 [Reference 4.1.2 of this report]  
 Limits: 47 CFR Part 15C Part 15.207 [Reference 4.1.1 of this report]

#### 5.1.2 Configuration of EUT

The EUT was placed on a wooden table 0.8m above the ground plane and connected to a LISN via a 1m mains cable. Details of the Peripheral and Ancillary Equipment connected for this test are listed in section 10.

During the initial scan, no discernible difference in emissions could be observed when operating on different channels or modulation schemes. For final test the EUT was operated in mode TX14 on Radio 1, TX27 on Radio 2, TX40 on Radio 3 and TX53 on Radio 4.

#### 5.1.3 Test procedure

Tests were made in accordance with FCC Part 15 using the measuring equipment listed in the 'Test Equipment' Section. Measurements were made on the live and neutral conductors using both average and quasi-peak detection.

At least 6 signals within 20dB and/or all signals within 10dB of the limit were investigated.

Tests were performed in Test Site F.

#### 5.1.4 Test equipment

E150, E035, ZSW1, E624, E411, E465

See Section 9 for more details

#### 5.1.5 Test results

Temperature of test environment 17°C  
 Humidity of test environment 50%  
 Pressure of test environment 102kPa

Band	57-66 GHz
Power Level	40 dBm
Channel Spacing	2.16 GHz
Mod Scheme	QPSK (MCS9)
Channel	Radio 1 58.32 GHz, Radio 2 60.48 GHz, Radio 3 62.64 GHz, Radio 4 64.8 GHz

Plot refs
9927-4 Cond 1 AC Live 150k-30M Average
9927-4 Cond 1 AC Live 150k-30M Quasi-Peak
9927-4 Cond 1 AC Neutral 150k-30M Average
9927-4 Cond 1 AC Neutral 150k-30M Quasi-Peak

**Table of signals measured for Cond 1 AC Live 150k-30M**

Signal No.	Freq (MHz)	Peak Amp (dBuV)	QP Amp (dBuV)	QP -Lim (dB)	AV Amp (dBuV)	AV -Lim (dB)
1	0.180	51.4	48.8	-15.7	37.3	-17.2
2	0.242	45.8	43.1	-18.9	33.9	-18.1
3	0.298	46.8	44.8	-15.5	33.5	-16.8
4	0.359	42.0	38.5	-20.3	26.2	-22.6
5	0.462	45.6	41.9	-14.8	19.4	-27.3
6	0.547	44.0	41.1	-14.9	29.9	-16.1
7	3.418	37.8	33.1	-22.9	24.1	-21.9
8	3.531	39.5	35.0	-21.0	25.9	-20.1
9	3.716	41.1	36.0	-20.0	26.2	-19.8
10	3.822	40.4	36.9	-19.1	26.5	-19.5
11	3.878	39.5	35.5	-20.5	25.5	-20.5
12	3.878	39.6	35.3	-20.7	24.9	-21.1

**Table of signals measured for Cond 1 AC Neutral 150k-30M**

Signal No.	Freq (MHz)	Peak Amp (dBuV)	QP Amp (dBuV)	QP -Lim (dB)	AV Amp (dBuV)	AV -Lim (dB)
1	0.177	48.6	38.3	-26.3	16.5	-38.1
2	0.248	37.5	31.5	-30.3	11.3	-40.5
3	0.320	35.1	31.0	-28.7	23.5	-26.2
4	0.451	35.1	30.8	-26.1	22.3	-24.6
5	0.536	43.8	41.1	-14.9	33.1	-12.9
6	0.641	39.1	38.0	-18.0	36.3	-9.7
7	3.701	40.3	36.4	-19.6	26.1	-19.9
8	3.730	42.3	36.3	-19.7	25.9	-20.1
9	3.793	39.8	35.7	-20.3	24.8	-21.2
10	3.829	38.0	34.5	-21.5	23.5	-22.5
11	3.970	37.3	34.3	-21.7	23.5	-22.5

Peak detector "Max held" Analyser plots against the Quasi-Peak / Average limit line(s) can be found in Section 6 of this report.

**LIMITS:**

15.207: as given in the above tables / drawn on the respective plots.

These results show that the EUT has PASSED this test.

The uncertainty gives a 95% confidence interval in the measurement. Expanded uncertainty (K=2) is as follows:

150kHz to 30MHz ±3.6dB.

## 5.2 Radiated emissions 9 - 150 kHz

NOT APPLICABLE: Lowest frequency generated is 45 MHz

## 5.3 Radiated emissions 150 kHz - 30 MHz

NOT APPLICABLE: Lowest frequency generated is 45 MHz

## 5.4 Radiated emissions 30 MHz -1 GHz

### 5.4.1 Test methods

Test Requirements: 47 CFR Part 15C Part 15.255(d)(2) [Reference 4.1.1 of this report]  
 Test Method: ANSI C63.10 Clause 6.3 & 6.5 [Reference 4.1.2 of this report]  
 Limits: 47 CFR Part 15C Part 15.255(d)(2) [Reference 4.1.1 of this report]

### 5.4.2 Configuration of EUT

The EUT was placed on a 0.8 metres high turntable. The front edge of the EUT was initially positioned facing the antenna. The EUT was measured at a distance of 3 metres. The EUT was examined in its normal use position. Radiated Emissions testing was performed whilst powered from 110 V AC. During the initial scan, no discernible difference in emissions could be observed when operating on different channels or modulation schemes. For final test the EUT was operated in mode TX14 on Radio 1, TX27 on Radio 2, TX40 on Radio 3 and TX53 on Radio 4.

### 5.4.3 Test procedure

Tests were made in accordance with FCC Part 15 using the measuring equipment listed below.

Measurements were made on a site listed with the FCC. The equipment was rotated 360 degrees and the antenna scanned 1 – 4 metres in both horizontal and vertical polarisations to record the worst case emissions.

At least 6 signals within 20dB and all signals within 10dB of the limit were investigated.

Tests were performed using Test Site M.

### 5.4.4 Test equipment

LPE364, E743, NSA-M, ZSW1, E624, E411, E465

See Section 9 for more details

### 5.4.5 Test results

Temperature of test environment 22°C  
 Humidity of test environment 42%  
 Pressure of test environment 103kPa

Band	57-66 GHz
Power Level	40 dBm
Channel Spacing	2.16 GHz
Mod Scheme	QPSK (MCS9)
Channel	Radio 1 58.32 GHz, Radio 2 60.48 GHz, Radio 3 62.64 GHz, Radio 4 64.8 GHz

Plot refs
9927-4 Rad 1 VHF Horiz
9927-4 Rad 1 VHF Vert
9927-4 Rad 1 UHF Horiz
9927-4 Rad 1 UHF Vert

Peak detector “Max held” Analyser plots against the Quasi-Peak / Average limit line(s) can be found in Section 6 of this report.

**Table of signals measured for Rad 1 Vertical 30M-1G**

Signal No.	Freq (MHz)	Peak Amp (dBuV/m)	QP Amp (dBuV/m)	QP -Lim (dB)
1	52.364	22.6	13.1	-26.9
2	63.103	19.9	11.9	-28.1
3	63.398	20.3	11.9	-28.1
4	73.580	20.5	12.3	-27.7

**Table of signals measured for Rad 1 Horizontal 30M-1G**

Signal No.	Freq (MHz)	Peak Amp (dBuV/m)	QP Amp (dBuV/m)	QP -Lim (dB)
No emissions were observed				

No discernible difference was noted in emissions between channel settings (exploratory measurements), therefore final measurements are presented for all four radios transmitting, each on a different channel.

**LIMITS:**

15.209 limits are applicable in the restricted bands of 15.205 with the relevant detector. The general limits of 15.209 are as drawn on the respective plots.

These results show that the EUT has PASSED this test.

The uncertainty gives a 95% confidence interval in the measurement. Expanded uncertainty (K=2) is as follows:  
30MHz - 1000MHz  $\pm 6.1$ dB

## 5.5 Radiated emissions above 1 GHz

### 5.5.1 Test methods

Test Requirements:	47 CFR Part 15C Part 15.255(d)(2)/(3)/(4) [Reference 4.1.1 of this report]
Test Method:	ANSI C63.10 Clause 6.3 & 6.6 & 9.8 [Reference 4.1.2 of this report]
Limits:	47 CFR Part 15C Part 15.255(d)(2)/(3)/(4) [Reference 4.1.1 of this report]

### 5.5.2 Configuration of EUT

The EUT was placed on a 1.5 metres high turntable. The front edge of the EUT was initially positioned facing the antenna. The EUT was measured at distances listed in 5.5.3. The EUT was examined in its normal use position. Radiated Emissions testing was performed whilst powered from 110 V AC. During the initial scan, worst modulation scheme was seen to be MCS0. All four radios were tested on all four channels. An assessment was made on the effect of having the beams from adjacent radios steered such that they overlapped. No increase in emission levels was noted and no extra intermodulation products were noted. The EUT was operated in TX5 and TX18 and TX31 and TX44 modes.

### 5.5.3 Test procedure

Tests were made in accordance with FCC Part 15 using the measuring equipment listed below.

Measurements were made in a semi-anechoic chamber with appropriate absorbing material for use in this range. Horn antennas were used at heights where the whole of the EUT was contained within the main beam. The EUT was rotated through 360 degrees to record the worst case emissions. A measurement distance of 3m was used between the test range 1 - 6GHz, 1.2m was used in the test range 6 - 18GHz, 0.3m was used in the test range 18 - 75GHz, 0.1m was used in the test range 75-110GHz and 0.1/0.03m was used in the test range 110-200 GHz. Pre scans over the EUT in all planes were made to identify any point sources of radiation, prior to any referenced measurements/plots taken.

At least 6 signals within 20dB and all signals within 10dB of the limit were investigated.

Tests were performed using test Sites A and B.

### 5.5.4 Test equipment

E289, E296-6, E329, E330, E412, E428, E485, E486-2, E487, E503, E562, E577, E579, E602, E638, E712, E714, E716, E719, E720, E722, E755, E760, E771, E781, TMS78, TMS79

See Section 9 for more details

### 5.5.5 Test results

Temperature of test environment	15-20°C
Humidity of test environment	40-49%
Pressure of test environment	100-102kPa

Setup Table

Band	57-66 GHz
Power Level	40 dBm
Channel Spacing	2.16 GHz
Mod Scheme	DBPSK (MCS0)
Low channel	58.32 GHz



Spurious Frequency (MHz)	Measured Peak Level (dBµV/m)	Difference to Peak Limit (dB)	Measured Average Level (dBµV/m)	Difference to Average Limit (dB)	EUT Polarisation	Antenna Polarisation
1562 (all radios)	42.2	-31.8	40.8	-13.2	Upright	Vertical
1562 (all radios)	40.7	-33.3	39.3	-14.7	Upright	Horizontal
1600 (all radios)	42.1	-31.9	41.1	-12.9	Upright	Vertical
1600 (all radios)	41.4	-32.6	39.9	-14.1	Upright	Horizontal
2500 (all radios)	42.0	-32.0	40.3	-13.7	Upright	Vertical
2500 (all radios)	42.1	-31.9	40.2	-13.8	Upright	Horizontal
5000 (all radios)	49.1	-24.9	47.3	-6.7	Upright	Vertical
5000 (all radios)	50.2	-23.8	48.3	-5.7	Upright	Horizontal
19440 (radio 1)	51.3	-22.7	49.4	-4.6	Upright	Vertical
19440 (radio 2)	46.0	-28.0	44.2	-9.8	Upright	Vertical
19440 (radio 3)	47.2	-26.8	44.9	-9.1	Upright	Vertical
19440 (radio 4)	48.2	-25.8	45.9	-8.1	Upright	Vertical

Setup Table

Band	57-66 GHz
Power Level	40 dBm
Channel Spacing	2.16 GHz
Mod Scheme	DBPSK (MCS0)
Mid channel 1	60.48 GHz

Spurious Frequency (MHz)	Measured Peak Level (dBµV/m)	Difference to Peak Limit (dB)	Measured Average Level (dBµV/m)	Difference to Average Limit (dB)	EUT Polarisation	Antenna Polarisation
1562 (all radios)	42.2	-31.8	40.8	-13.2	Upright	Vertical
1562 (all radios)	40.7	-33.3	39.3	-14.7	Upright	Horizontal
1600 (all radios)	42.1	-31.9	41.1	-12.9	Upright	Vertical
1600 (all radios)	41.4	-32.6	39.9	-14.1	Upright	Horizontal
2500 (all radios)	42.0	-32.0	40.3	-13.7	Upright	Vertical
2500 (all radios)	42.1	-31.9	40.2	-13.8	Upright	Horizontal
5000 (all radios)	49.1	-24.9	47.3	-6.7	Upright	Vertical
5000 (all radios)	50.2	-23.8	48.3	-5.7	Upright	Horizontal
20159 (radio 1)	47.9	-26.1	44.5	-9.5	Upright	Vertical
20159 (radio 2)	47.6	-26.4	44.5	-9.5	Upright	Vertical
20159 (radio 3)	44.8	-29.2	41.6	-12.4	Upright	Vertical
20159 (radio 4)	44.6	-29.4	41.4	-12.6	Upright	Vertical

Setup Table

Band	57-66 GHz
Power Level	40 dBm
Channel Spacing	2.16 GHz
Mod Scheme	DBPSK (MCS0)
Mid channel 2	62.64 GHz

Spurious Frequency (MHz)	Measured Peak Level (dBµV/m)	Difference to Peak Limit (dB)	Measured Average Level (dBµV/m)	Difference to Average Limit (dB)	EUT Polarisation	Antenna Polarisation
1562 (all radios)	42.2	-31.8	40.8	-13.2	Upright	Vertical
1562 (all radios)	40.7	-33.3	39.3	-14.7	Upright	Horizontal
1600 (all radios)	42.1	-31.9	41.1	-12.9	Upright	Vertical
1600 (all radios)	41.4	-32.6	39.9	-14.1	Upright	Horizontal
2500 (all radios)	42.0	-32.0	40.3	-13.7	Upright	Vertical
2500 (all radios)	42.1	-31.9	40.2	-13.8	Upright	Horizontal
5000 (all radios)	49.1	-24.9	47.3	-6.7	Upright	Vertical
5000 (all radios)	50.2	-23.8	48.3	-5.7	Upright	Horizontal
20879 (radio 1)	47.1	-26.9	42.8	-11.2	Upright	Vertical
20879 (radio 2)	43.9	-30.1	41.8	-12.2	Upright	Vertical
20879 (radio 3)	49.7	-24.3	47.5	-6.5	Upright	Vertical
20879 (radio 4)	46.5	-27.5	42.8	-11.2	Upright	Vertical

Plots	
9927-4 Rad 1 62.64 GHz mcs 0 beam 33 rad em 1-3 GHz horiz	
9927-4 Rad 1 62.64 GHz mcs 0 beam 33 rad em 1-3 GHz vert	
9927-4 Rad 1 62.64 GHz mcs 0 beam 33 rad em 3-6 GHz horiz	
9927-4 Rad 1 62.64 GHz mcs 0 beam 33 rad em 3-6 GHz vert	
9927-4 Rad 1 62.64 GHz mcs 0 beam 33 rad em 6-9 GHz horiz	
9927-4 Rad 1 62.64 GHz mcs 0 beam 33 rad em 6-9 GHz vert	
9927-4 Rad 1 62.64 GHz mcs 0 beam 33 rad em 9-12.5 GHz horiz	
9927-4 Rad 1 62.64 GHz mcs 0 beam 33 rad em 9-12.5 GHz vert	
9927-4 Rad 1 62.64 GHz mcs 0 beam 33 rad em 12.5-15 GHz	
9927-4 Rad 1 62.64 GHz mcs 0 beam 33 rad em 15-18 GHz	
9927-4 Rad 1 62.64 GHz mcs 0 beam 33 rad em 18-22 GHz	
9927-4 Rad 1 62.64 GHz mcs 0 beam 33 rad em 22-26 GHz	
9927-4 Rad 1 62.64 GHz mcs 0 beam 33 rad em 26-26.5 GHz	
9927-4 Rad 1 62.64 GHz mcs 0 beam 33 rad em 26.5-30 GHz	
9927-4 Rad 1 62.64 GHz mcs 0 beam 33 rad em 30-34 GHz	
9927-4 Rad 1 62.64 GHz mcs 0 beam 33 rad em 34-38 GHz	
9927-4 Rad 1 62.64 GHz mcs 0 beam 33 rad em 38-40 GHz	
9927-4 Rad 1 62.64 GHz mcs 0 beam 33 rad em 40-44 GHz	
9927-4 Rad 1 62.64 GHz mcs 0 beam 33 rad em 44-48 GHz	
9927-4 Rad 1 62.64 GHz mcs 0 beam 33 rad em 48-50 GHz	
9927-4 Rad 1 62.64 GHz mcs 0 beam 33 rad em 50-54 GHz	
9927-4 Rad 1 62.64 GHz mcs 0 beam 33 rad em 54-58 GHz	
9927-4 Rad 1 62.64 GHz mcs 0 beam 33 rad em 70.9-75 GHz	
9927-4 Rad 1 62.64 GHz mcs 0 beam 33 rad em 75-79 GHz	
9927-4 Rad 1 62.64 GHz mcs 0 beam 33 rad em 79-83 GHz	
9927-4 Rad 1 62.64 GHz mcs 0 beam 33 rad em 83-87 GHz	
9927-4 Rad 1 62.64 GHz mcs 0 beam 33 rad em 87-90 GHz	
9927-4 Rad 1 62.64 GHz mcs 0 beam 33 rad em 90-140 GHz	
9927-4 Rad 1 62.64 GHz mcs 0 beam 33 rad em 140-170 GHz	
9927-4 Rad 1 62.64 GHz mcs 0 beam 33 rad em 170-200 GHz	

Peak detector "Max held" Analyser plots against the Average limit line can be found in Section 6 of this report.

Note: Whilst all channels were tested on all four radios, plots are for illustrative purposes only and only plots for channel 62.64 GHz on Radio 1 are shown in this report.

Setup Table

Band	57-66 GHz
Power Level	40 dBm
Channel Spacing	2.16 GHz
Mod Scheme	DBPSK (MCS0)
High channel	64.8 GHz

Spurious Frequency (MHz)	Measured Peak Level (dB $\mu$ V/m)	Difference to Peak Limit (dB)	Measured Average Level (dB $\mu$ V/m)	Difference to Average Limit (dB)	EUT Polarisation	Antenna Polarisation
1562 (all radios)	42.2	-31.8	40.8	-13.2	Upright	Vertical
1562 (all radios)	40.7	-33.3	39.3	-14.7	Upright	Horizontal
1600 (all radios)	42.1	-31.9	41.1	-12.9	Upright	Vertical
1600 (all radios)	41.4	-32.6	39.9	-14.1	Upright	Horizontal
2500 (all radios)	42.0	-32.0	40.3	-13.7	Upright	Vertical
2500 (all radios)	42.1	-31.9	40.2	-13.8	Upright	Horizontal
5000 (all radios)	49.1	-24.9	47.3	-6.7	Upright	Vertical
5000 (all radios)	50.2	-23.8	48.3	-5.7	Upright	Horizontal
21600 (radio 1)	49.0	-25.0	45.0	-9.0	Upright	Vertical
21600 (radio 2)	52.7	-21.3	51.6	-2.4	Upright	Vertical
21600 (radio 3)	52.1	-21.9	51.3	-2.7	Upright	Vertical
21600 (radio 4)	46.5	-27.5	44.8	-9.2	Upright	Vertical

**LIMITS:**

15.209 limits are applicable in the restricted bands of 15.205 with the relevant detector.

15.255 (d)(3) between 40 GHz and 200 GHz the level of the emissions shall not exceed 90pW/cm<sup>2</sup> at a distance of 3m. This is equivalent to 85.1dB $\mu$ V/m @ a distance of 3m. Calculations are based on ANSI C63.10 clauses 9.4 – 9.7.

The general limits of 15.209 are as drawn on the respective plots.

These results show that the EUT has PASSED this test.

The uncertainty gives a 95% confidence interval in the measurement. Expanded uncertainty (K=2) is as follows:

1 – 18 GHz  $\pm$ 3.5dB, 18 – 26.5 GHz  $\pm$ 3.9dB, 26.5 – 60 GHz  $\pm$ 3.9dB, 60 – 110 GHz  $\pm$ 4.4dB, 110 – 200 GHz  $\pm$ 5.9dB.

## 5.6 Frequency stability

### 5.6.1 Test methods

Test Requirements:	47 CFR Part 15C Part 15.255(f) [Reference 4.1.1 of this report]
Test Method:	ANSI C63.10 Clause 6.8 / 9.14 [Reference 4.1.2 of this report]
Limits:	47 CFR Part 15C Part 15.255(f) [Reference 4.1.1 of this report]

### 5.6.2 Configuration of EUT

The EUT was placed in a temperature controlled chamber. The EUT's emissions were observed by means of a test fixture. The EUT was operated in TX1 and TX2 and TX3 and TX4 modes for this test.

### 5.6.3 Test procedure

Tests were made in accordance with FCC Part 15 using the measuring equipment listed below. Temperature stability was achieved at each test temperature level before taking measurements using a counter function of a spectrum analyser, adjusted for the tone offset (99.687MHz).

Tests were performed using Test Site N.

### 5.6.4 Test equipment

E412, E485, E503, E555, E638, E807, S036, TMS57, TMS80

See Section 9 for more details

### 5.6.5 Test results

Temperature of test environment	18-24°C
Humidity of test environment	42-54%
Pressure of test environment	100kPa

Band	57-66 GHz
Power Level	40 dBm
Channel Spacing	2.16 GHz
Mod Scheme	CW (99.687MHz tone)
Low channel	58.32 GHz
Mid channel 1	60.48 GHz
Mid channel 2	62.64 GHz
High channel	64.8 GHz

Test conditions		Frequency Error (MHz) Low channel	Frequency Error (MHz) Mid channel 1	Frequency Error (MHz) Mid channel 2	Frequency Error (MHz) High channel
-20°C	Volts Nominal (110)	58319.801622	60479.794387	62639.787404	64799.779922
-10°C	Volts Nominal (110)	58319.806999	60479.799742	62639.792454	64799.785247
0°C	Volts Nominal (110)	58319.806302	60479.799322	62639.792249	64799.785243
10°C	Volts Nominal (110)	58319.808455	60479.801567	62639.794734	64799.787812
20°C	Volts Minimum (93.5)	58319.809554	60479.794304	62639.795820	64799.788940
	Volts Nominal (110)	58319.809593	60479.802682	62639.795875	64799.789037
	Volts Maximum (126.5)	58319.809563	60479.794267	62639.795858	64799.788952

30°C	Volts Nominal (110)	58319.809762	60479.803090	62639.796298	64799.789537
40°C	Volts Nominal (110)	58319.812456	60479.805639	62639.798782	64799.791888
50°C	Volts Nominal (110)	58319.813616	60479.806465	62639.799284	64799.791852
Max Frequency Error per chan (Hz)		+186384 / -198378	+193535 / -205733	+200716 / -212596	+208112 / -220078
Max Frequency Error observed (MHz)		-0.198378	-0.205733	-0.212596	-0.220078

Results shown above have been corrected for the offset tone of 99.687 MHz.

Maximum variation observed was -0.220078 MHz. Refer to 6dB BW test results for BW of signal contained within the band 57-66GHz.

**LIMITS:**

15.255 (f) Fundamental emissions must be contained within the frequency band specified during all conditions of operation.

These results show that the EUT has PASSED this test.

The uncertainty gives a 95% confidence interval in the measurement. Expanded uncertainty (K=2) is as follows:

<± 0.7 ppm

## 5.7 Peak & Average EIRP

### 5.7.1 Test methods

Test Requirements:	47 CFR Part 15C Part 15.255(c)(1)(i)/(ii) [Reference 4.1.1 of this report]
Test Method:	ANSI C63.10 Clause 9.10 & 9.11 [Reference 4.1.2 of this report]
Limits:	47 CFR Part 15C Part 15.255(c)(1)(i)/(ii) [Reference 4.1.1 of this report]

### 5.7.2 Configuration of EUT

The EUT was placed on a 1.5 metres high turntable. The EUT antenna was positioned and aligned with the measuring antenna. The EUT was measured at a distance of 25 centimetres. EIRP testing was performed whilst powered from 110 V AC. During the initial scan, no discernible difference in emissions could be observed when operating using different modulation schemes. Each of the four radios were tested on all four channels. An assessment was made on the effect of having the beams from adjacent radios steered such that they overlapped. Power levels noted from overlapped beams from adjacent radios was not higher than the maximum power observed from single steered beams around the middle of the antenna arrays. The EUT was operated in TX14 and TX27 and TX40 and TX53 modes.

### 5.7.3 Test procedure

Tests were made in accordance with FCC Part 15 using the measuring equipment listed below.

Measurements were made in a semi-anechoic chamber with appropriate absorbing material for use in this range. A Horn antenna was used to align with and measure the radiated power from the EUT. A wideband RF detector was used with a digital oscilloscope to measure the Peak and Average power. A measurement distance of 25 cm was used to maintain the far field condition at the frequency of interest whilst maintaining enough EUT transmitted signal into the mixer. Substitution was performed to determine results.

Tests were performed using test Site A.

### 5.7.4 Test equipment

E500, E503, E577, E600, E602, E627, E781, E829, E852

See Section 9 for more details

### 5.7.5 Test results

Temperature of test environment	18°C
Humidity of test environment	34%
Pressure of test environment	104kPa

Band	57-66 (radio 1) GHz
Power Level	40 dBm
Channel Spacing	2.16 GHz
Mod Scheme	QPSK (MCS9)
Low channel	58.32 GHz
Mid channel 1	60.48 GHz
Mid channel 2	62.64 GHz
High channel	64.8 GHz

Test conditions	dBm	dBm	dBm	dBm
Peak EIRP measured	38.80	38.00	38.30	37.30
Beam setting for maximum	26	29	33	32

Band	57-66 (radio 2) GHz
Power Level	40 dBm
Channel Spacing	2.16 GHz
Mod Scheme	QPSK (MCS9)

Low channel	58.32 GHz
Mid channel 1	60.48 GHz
Mid channel 2	62.64 GHz
High channel	64.8 GHz

Test conditions	dBm	dBm	dBm	dBm
Peak EIRP measured	38.10	37.40	37.90	37.90
Beam setting for maximum	26	15	12	11

Band	57-66 (radio 3) GHz
Power Level	40 dBm
Channel Spacing	2.16 GHz
Mod Scheme	QPSK (MCS9)
Low channel	58.32 GHz
Mid channel 1	60.48 GHz
Mid channel 2	62.64 GHz
High channel	64.8 GHz

Test conditions	dBm	dBm	dBm	dBm
Peak EIRP measured	39.10	38.50	38.50	37.00
Beam setting for maximum	26	29	30	11

Band	57-66 (radio 4) GHz
Power Level	40 dBm
Channel Spacing	2.16 GHz
Mod Scheme	QPSK (MCS9)
Low channel	58.32 GHz
Mid channel 1	60.48 GHz
Mid channel 2	62.64 GHz
High channel	64.8 GHz

Test conditions	dBm	dBm	dBm	dBm
Peak EIRP measured	39.90	39.40	39.60	39.10
Beam setting for maximum	26	20	30	14

Band	57-66 GHz (radio 4 & 3)
Power Level	40 dBm
Channel Spacing	2.16 GHz
Mod Scheme	QPSK (MCS9)
Low channel	58.32 GHz Radio 4
Mid channel 1	60.48 GHz Radio 3

Test conditions	dBm
Peak EIRP measured	38.10
Beam setting for maximum overlap	Rad 4 Beam 7 with Rad 3 Beam 57

As the peak EIRP measured does not exceed the average EIRP limit, only peak values are recorded.

**LIMITS:**

15.255 (c)(i) the average power of any emission shall not exceed 40 dBm and the peak power of any emission shall not exceed 43 dBm .

These results show that the EUT has PASSED this test.

The uncertainty gives a 95% confidence interval in the measurement. Expanded uncertainty (K=2) is as follows:  
 $\pm 5.3$  dB.



## 5.8 Peak Conducted Power

NOT APPLICABLE: EUT does not have a conducted RF port.

## 5.9 6dB Occupied bandwidth

### 5.9.1 Test methods

Test Requirements: 47 CFR Part 15C Part 15.255(e)1 [Reference 4.1.1 of this report]  
 Test Method: ANSI C63.10 Clause 9.3 [Reference 4.1.2 of this report]  
 Limits: 47 CFR Part 15C Part 15.255(e)1 [Reference 4.1.1 of this report]

### 5.9.2 Configuration of EUT

The EUT was placed on a 1.5 metres high turntable. The front edge of the EUT was initially positioned facing the antenna. The EUT was measured at a distance of 3 metres. The EUT was tested whilst connected to the AC power for maximised emissions. The EUT was operated in TX5 to TX56 modes.

### 5.9.3 Test procedure

Tests were made in accordance with FCC Part 15 using the measuring equipment listed below. A 100 kHz RBW, 3x VBW, peak detector, auto sweep time and max hold settings were used for the 6 dB bandwidth.

Tests were performed using test Site A.

### 5.9.4 Test equipment

E412, E485, E503, E555, E638

See Section 9 for more details

### 5.9.5 Test results

Temperature of test environment 18-22°C  
 Humidity of test environment 45-58%  
 Pressure of test environment 101-102kPa

Band	57-66 GHz
Power Level	40 dBm
Channel Spacing	2.16 GHz
Mod Scheme	DBPSK (MCS0)
Low channel	58.32 GHz
Mid channel 1	60.48 GHz
Mid channel 2	62.64 GHz
High channel	64.8 GHz

	Low channel	Mid channel 1	Mid channel 2	High channel
6 dB Bandwidth (MHz) Nominal Temp & Volts	1581.7	1581.7	1554.8	1554.3
Plot for 6 dB Bandwidth (MHz) Nominal Temp & Volts	9927-4 radio1 58.32GHz mcs0 6dB	9927-4 radio1 60.48GHz mcs0 6dB	9927-4 radio1 62.64GHz mcs0 6dB	9927-4 radio1 64.8GHz mcs0 6dB

Band	57-66 GHz
Power Level	40 dBm
Channel Spacing	2.16 GHz
Mod Scheme	BPSK (MCS1)
Low channel	58.32 GHz
Mid channel 1	60.48 GHz
Mid channel 2	62.64 GHz
High channel	64.8 GHz

	Low channel	Mid channel 1	Mid channel 2	High channel
6 dB Bandwidth (MHz) Nominal Temp & Volts	1588.6	1598.6	1602.8	1592.2
Plot for 6 dB Bandwidth (MHz) Nominal Temp & Volts	9927-4 radio1 58.32GHz mcs1 6dB	9927-4 radio1 60.48GHz mcs1 6dB	9927-4 radio1 62.64GHz mcs1 6dB	9927-4 radio1 64.8GHz mcs1 6dB

Band	57-66 GHz
Power Level	40 dBm
Channel Spacing	2.16 GHz
Mod Scheme	BPSK (MCS2)
Low channel	58.32 GHz
Mid channel 1	60.48 GHz
Mid channel 2	62.64 GHz
High channel	64.8 GHz

	Low channel	Mid channel 1	Mid channel 2	High channel
6 dB Bandwidth (MHz) Nominal Temp & Volts	1622.3	1640.2	1529	1581.2
Plot for 6 dB Bandwidth (MHz) Nominal Temp & Volts	9927-4 radio1 58.32GHz mcs2 6dB	9927-4 radio1 60.48GHz mcs2 6dB	9927-4 radio1 62.64GHz mcs2 6dB	9927-4 radio1 64.8GHz mcs2 6dB

Band	57-66 GHz
Power Level	40 dBm
Channel Spacing	2.16 GHz
Mod Scheme	BPSK (MCS3)
Low channel	58.32 GHz
Mid channel 1	60.48 GHz
Mid channel 2	62.64 GHz
High channel	64.8 GHz

	Low channel	Mid channel 1	Mid channel 2	High channel
6 dB Bandwidth (MHz) Nominal Temp & Volts	1584.9	1654	1622.3	1582.8
Plot for 6 dB Bandwidth (MHz) Nominal Temp & Volts	9927-4 radio1 58.32GHz mcs3 6dB	9927-4 radio1 60.48GHz mcs3 6dB	9927-4 radio1 62.64GHz mcs3 6dB	9927-4 radio1 64.8GHz mcs3 6dB

Band	57-66 GHz
Power Level	40 dBm
Channel Spacing	2.16 GHz
Mod Scheme	BPSK (MCS4)
Low channel	58.32 GHz
Mid channel 1	60.48 GHz
Mid channel 2	62.64 GHz
High channel	64.8 GHz

	Low channel	Mid channel 1	Mid channel 2	High channel
6 dB Bandwidth (MHz) Nominal Temp & Volts	1553.7	1649.7	1581.2	1599.1
Plot for 6 dB Bandwidth (MHz) Nominal Temp & Volts	9927-4 radio1 58.32GHz mcs4 6dB	9927-4 radio1 60.48GHz mcs4 6dB	9927-4 radio1 62.64GHz mcs4 6dB	9927-4 radio1 64.8GHz mcs4 6dB

Band	57-66 GHz
Power Level	40 dBm
Channel Spacing	2.16 GHz
Mod Scheme	BPSK (MCS5)
Low channel	58.32 GHz
Mid channel 1	60.48 GHz
Mid channel 2	62.64 GHz
High channel	64.8 GHz

	Low channel	Mid channel 1	Mid channel 2	High channel
6 dB Bandwidth (MHz) Nominal Temp & Volts	1526.3	1594.9	1632.9	1550.1
Plot for 6 dB Bandwidth (MHz) Nominal Temp & Volts	9927-4 radio1 58.32GHz mcs5 6dB	9927-4 radio1 60.48GHz mcs5 6dB	9927-4 radio1 62.64GHz mcs5 6dB	9927-4 radio1 64.8GHz mcs5 6dB

Band	57-66 GHz
Power Level	40 dBm
Channel Spacing	2.16 GHz
Mod Scheme	QPSK (MCS6)
Low channel	58.32 GHz
Mid channel 1	60.48 GHz
Mid channel 2	62.64 GHz
High channel	64.8 GHz

	Low channel	Mid channel 1	Mid channel 2	High channel
6 dB Bandwidth (MHz) Nominal Temp & Volts	1581.2	1664	1622.3	1613.3
Plot for 6 dB Bandwidth (MHz) Nominal Temp & Volts	9927-4 radio1 58.32GHz mcs6 6dB	9927-4 radio1 60.48GHz mcs6 6dB	9927-4 radio1 62.64GHz mcs6 6dB	9927-4 radio1 64.8GHz mcs6 6dB

Band	57-66 GHz
Power Level	40 dBm
Channel Spacing	2.16 GHz
Mod Scheme	QPSK (MCS7)
Low channel	58.32 GHz
Mid channel 1	60.48 GHz
Mid channel 2	62.64 GHz
High channel	64.8 GHz

	Low channel	Mid channel 1	Mid channel 2	High channel
6 dB Bandwidth (MHz) Nominal Temp & Volts	1608.6	1667.1	1677.7	1636
Plot for 6 dB Bandwidth (MHz) Nominal Temp & Volts	9927-4 radio1 58.32GHz mcs7 6dB	9927-4 radio1 60.48GHz mcs7 6dB	9927-4 radio1 62.64GHz mcs7 6dB	9927-4 radio1 64.8GHz mcs7 6dB

Band	57-66 GHz
Power Level	40 dBm
Channel Spacing	2.16 GHz
Mod Scheme	QPSK (MCS8)
Low channel	58.32 GHz
Mid channel 1	60.48 GHz
Mid channel 2	62.64 GHz
High channel	64.8 GHz

	Low channel	Mid channel 1	Mid channel 2	High channel
6 dB Bandwidth (MHz) Nominal Temp & Volts	1581.7	1654	1663.4	1636.5
Plot for 6 dB Bandwidth (MHz) Nominal Temp & Volts	9927-4 radio1 58.32GHz mcs8 6dB	9927-4 radio1 60.48GHz mcs8 6dB	9927-4 radio1 62.64GHz mcs8 6dB	9927-4 radio1 64.8GHz mcs8 6dB

Band	57-66 GHz
Power Level	40 dBm
Channel Spacing	2.16 GHz
Mod Scheme	QPSK (MCS9)
Low channel	58.32 GHz
Mid channel 1	60.48 GHz
Mid channel 2	62.64 GHz
High channel	64.8 GHz

	Low channel	Mid channel 1	Mid channel 2	High channel
6 dB Bandwidth (MHz) Nominal Temp & Volts	1595.4	1677.7	1635.5	1636.5
Plot for 6 dB Bandwidth (MHz) Nominal Temp & Volts	9927-4 radio1 58.32GHz mcs9 6dB	9927-4 radio1 60.48GHz mcs9 6dB	9927-4 radio1 62.64GHz mcs9 6dB	9927-4 radio1 64.8GHz mcs9 6dB

Band	57-66 GHz
Power Level	40 dBm
Channel Spacing	2.16 GHz
Mod Scheme	QPSK (MCS10)
Low channel	58.32 GHz
Mid channel 1	60.48 GHz
Mid channel 2	62.64 GHz
High channel	64.8 GHz

	Low channel	Mid channel 1	Mid channel 2	High channel
6 dB Bandwidth (MHz) Nominal Temp & Volts	1621.8	1609.1	1595.4	1636.5
Plot for 6 dB Bandwidth (MHz) Nominal Temp & Volts	9927-4 radio1 58.32GHz mcs10 6dB	9927-4 radio1 60.48GHz mcs10 6dB	9927-4 radio1 62.64GHz mcs10 6dB	9927-4 radio1 64.8GHz mcs10 6dB

Band	57-66 GHz
Power Level	40 dBm
Channel Spacing	2.16 GHz
Mod Scheme	QPSK (MCS11)
Low channel	58.32 GHz
Mid channel 1	60.48 GHz
Mid channel 2	62.64 GHz
High channel	64.8 GHz

	Low channel	Mid channel 1	Mid channel 2	High channel
6 dB Bandwidth (MHz) Nominal Temp & Volts	1581.7	1595.4	1663.4	1636.5
Plot for 6 dB Bandwidth (MHz) Nominal Temp & Volts	9927-4 radio1 58.32GHz mcs11 6dB	9927-4 radio1 60.48GHz mcs11 6dB	9927-4 radio1 62.64GHz mcs11 6dB	9927-4 radio1 64.8GHz mcs11 6dB

Band	57-66 GHz
Power Level	40 dBm
Channel Spacing	2.16 GHz
Mod Scheme	QPSK (MCS12)
Low channel	58.32 GHz
Mid channel 1	60.48 GHz
Mid channel 2	62.64 GHz
High channel	64.8 GHz

	Low channel	Mid channel 1	Mid channel 2	High channel
6 dB Bandwidth (MHz) Nominal Temp & Volts	1526.3	1636	1636.5	1636.5
Plot for 6 dB Bandwidth (MHz) Nominal Temp & Volts	9927-4 radio1 58.32GHz mcs12 6dB	9927-4 radio1 60.48GHz mcs12 6dB	9927-4 radio1 62.64GHz mcs12 6dB	9927-4 radio1 64.8GHz mcs12 6dB

Analyser plots for the 6dB bandwidth can be found in Section 6 of this report.

**LIMITS:**

15.255(e)1 & 15.255(f) The 6dB bandwidth of the emission must be contained within the designated frequency band.

These results show that the EUT has PASSED this test.

The uncertainty gives a 95% confidence interval in the measurement. Expanded uncertainty (K=2) is as follows:

<± 1.9 %.

## 6 Plots/Graphical results

### 6.1 AC power line conducted emissions

RF Parameters: Band 57-66 GHz, Power 40 dBm, Channel Spacing 2.16 GHz, Modulation QPSK (MCS9), Channel All radios TX

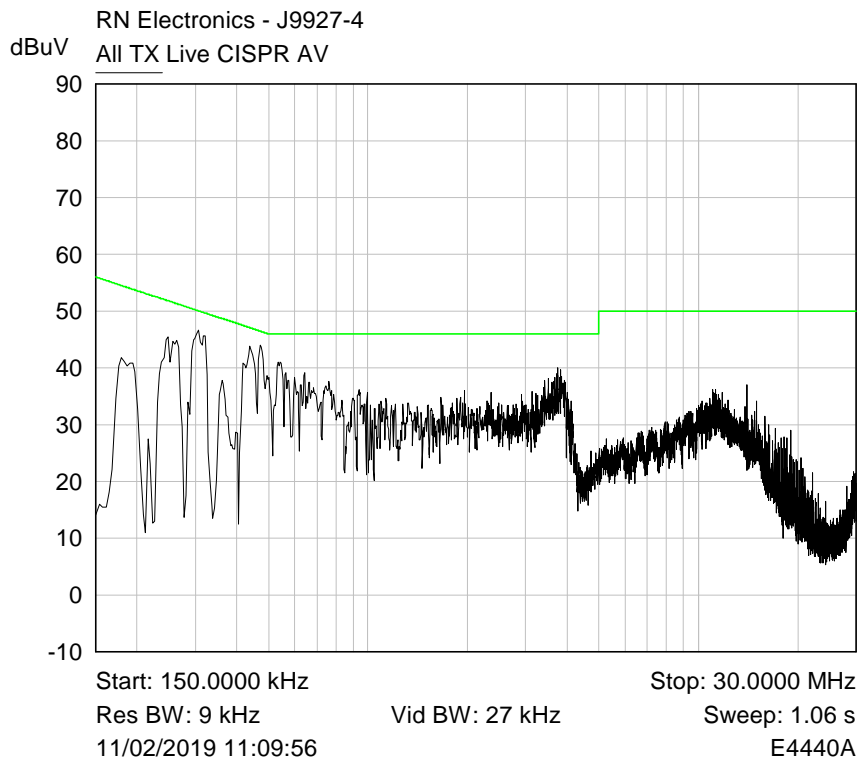

Plot of Live150k-30M Average

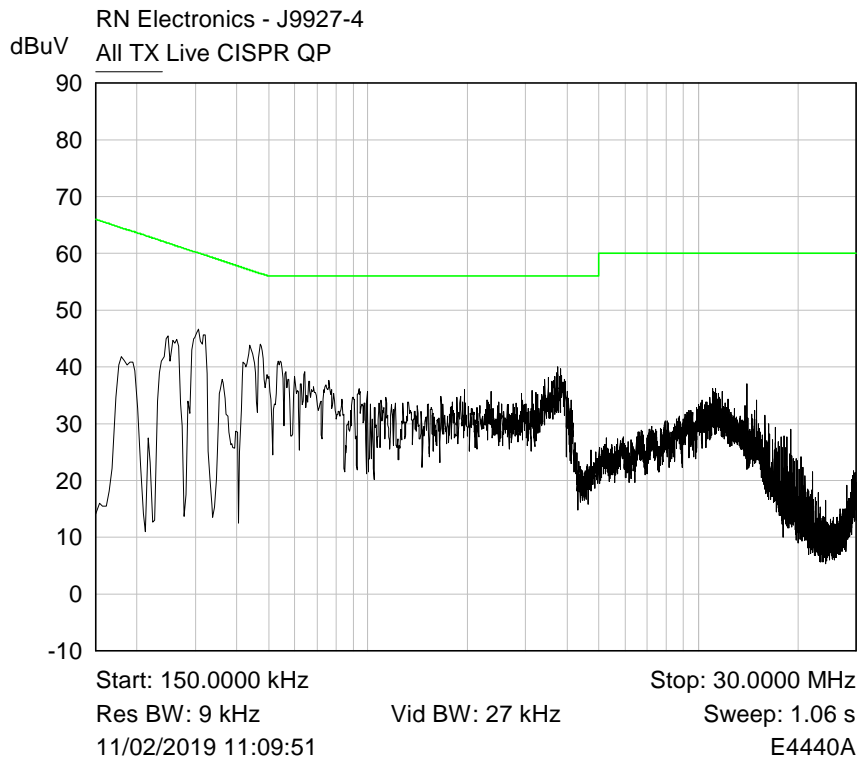

Plot of Live150k-30M Quasi-Peak

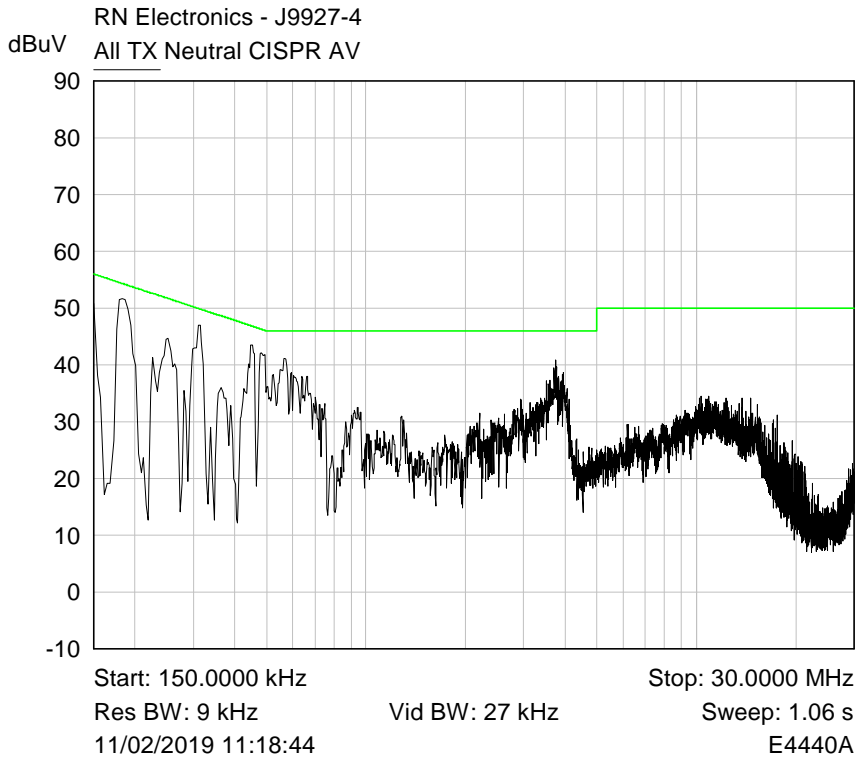

Plot of Neutral150k-30M Average

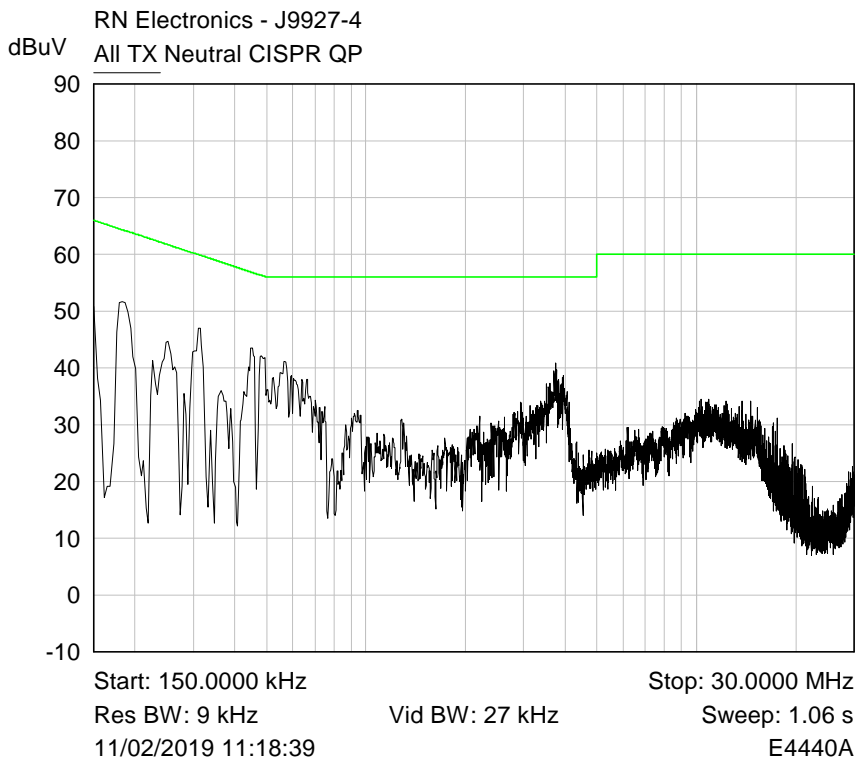

Plot of Neutral150k-30M Quasi-Peak



## 6.2 Radiated emissions 30 MHz -1 GHz

RF Parameters: Band 57-66 GHz, Power 40 dBm, Channel Spacing 2.16 GHz, Modulation QPSK (MCS9), Channel All radios TX

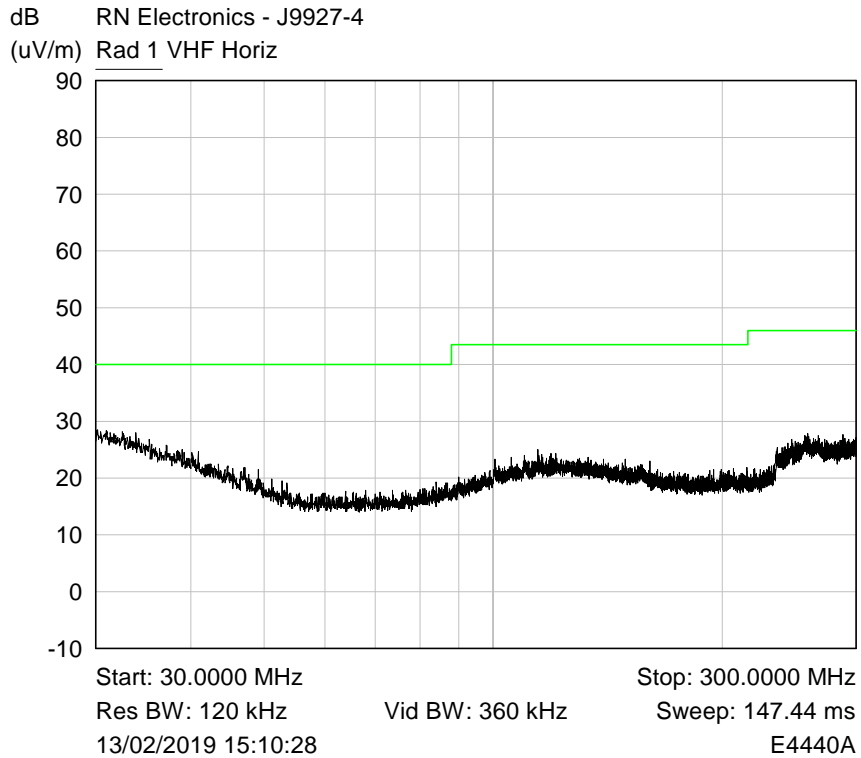

Plot of Peak emissions for VHF Horizontal against the QP limit line.

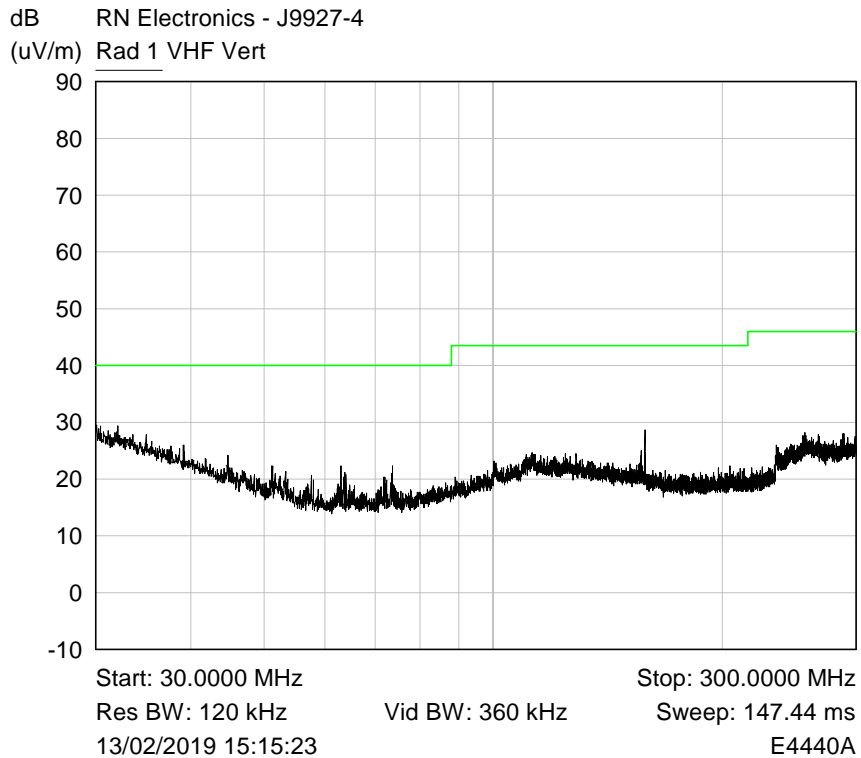

Plot of Peak emissions for VHF Vertical against the QP limit line.

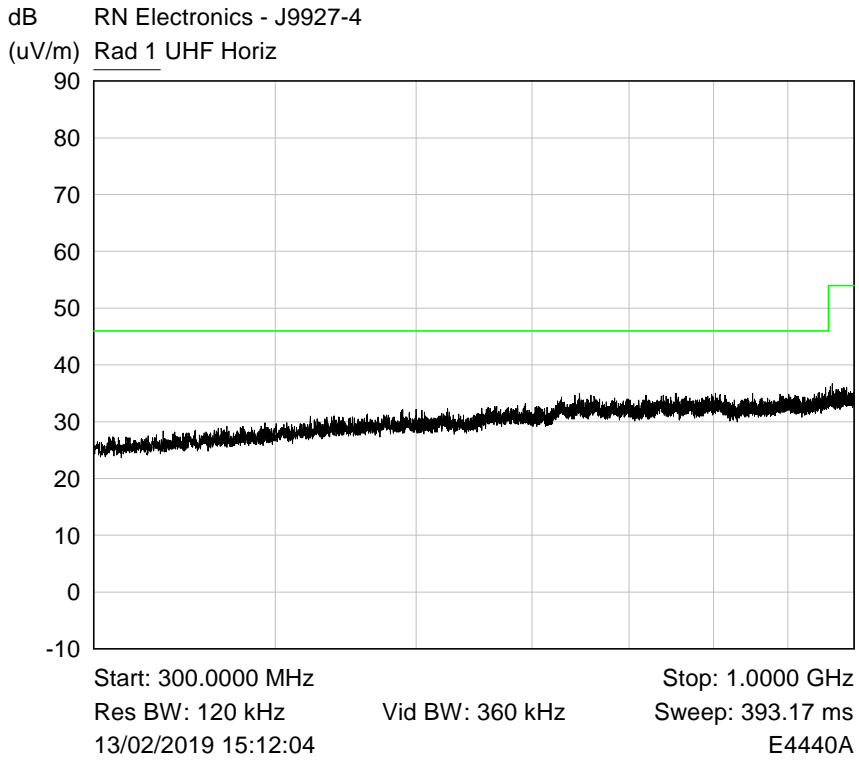

Plot of Peak emissions for UHF Horizontal against the QP limit line.

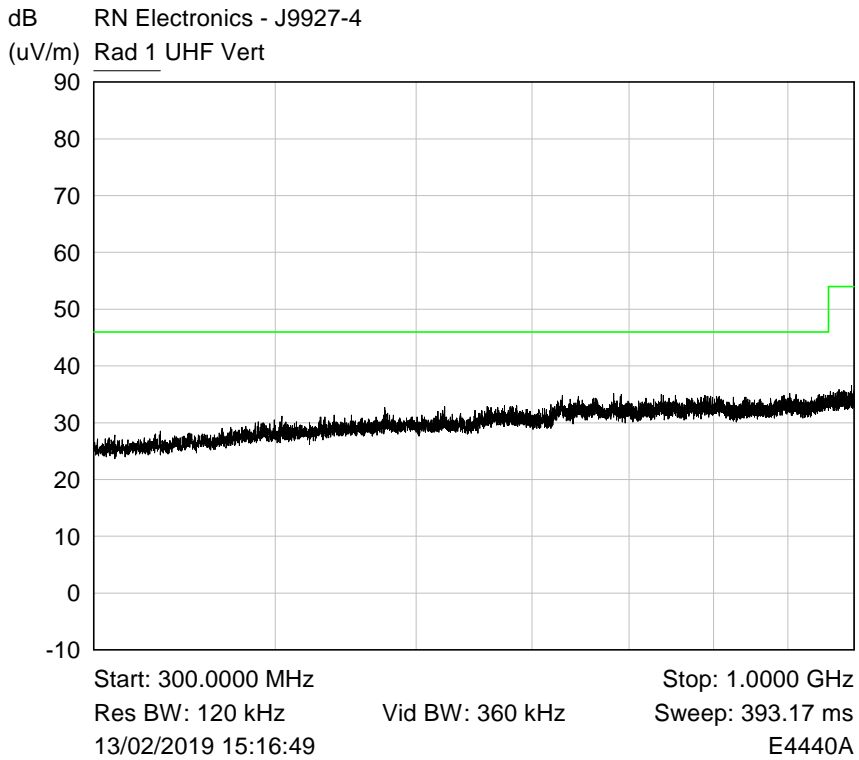

Plot of Peak emissions for UHF Vertical against the QP limit line.

### 6.3 Radiated emissions above 1 GHz

RF Parameters: Band 57-66 GHz, Power 40 dBm, Channel Spacing 2.16 GHz, Modulation DBPSK (MCS0), Channel 62.64 GHz

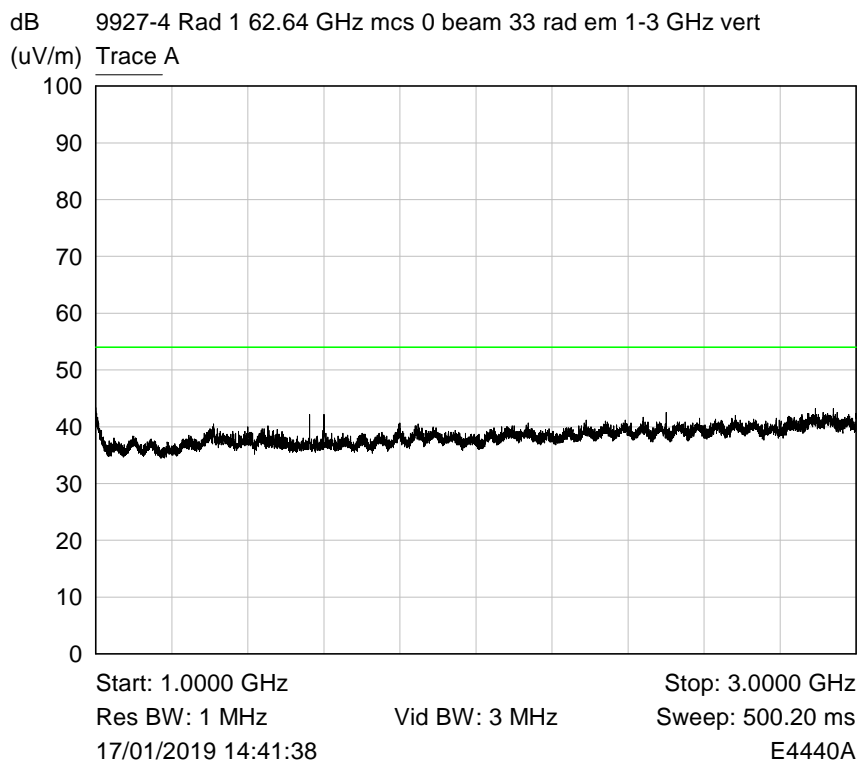
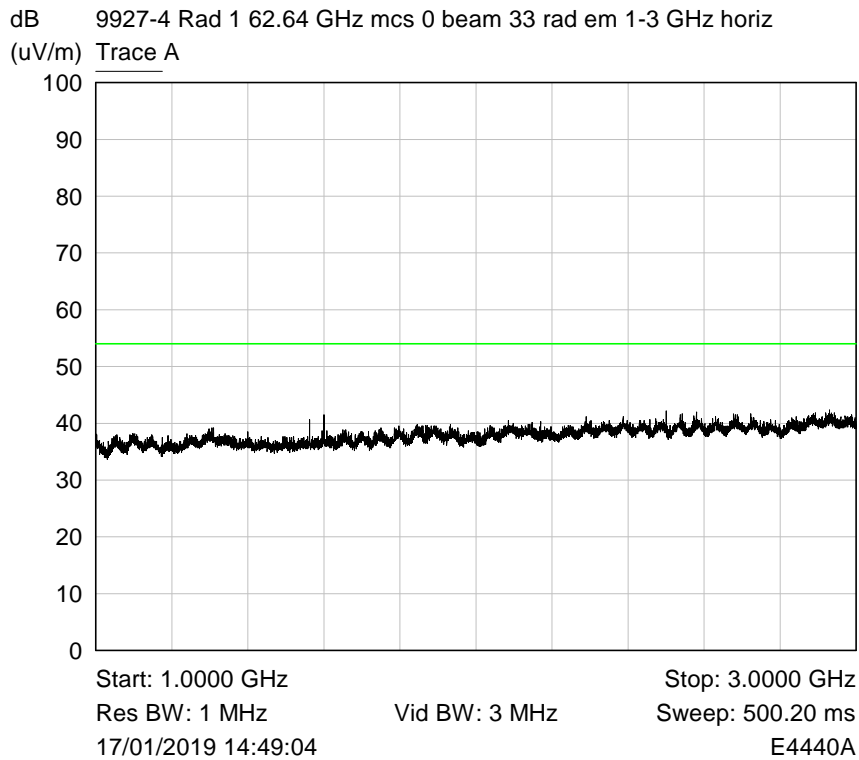

dB 9927-4 Rad 1 62.64 GHz mcs 0 beam 33 rad em 3-6 GHz horiz

(uV/m) Trace A

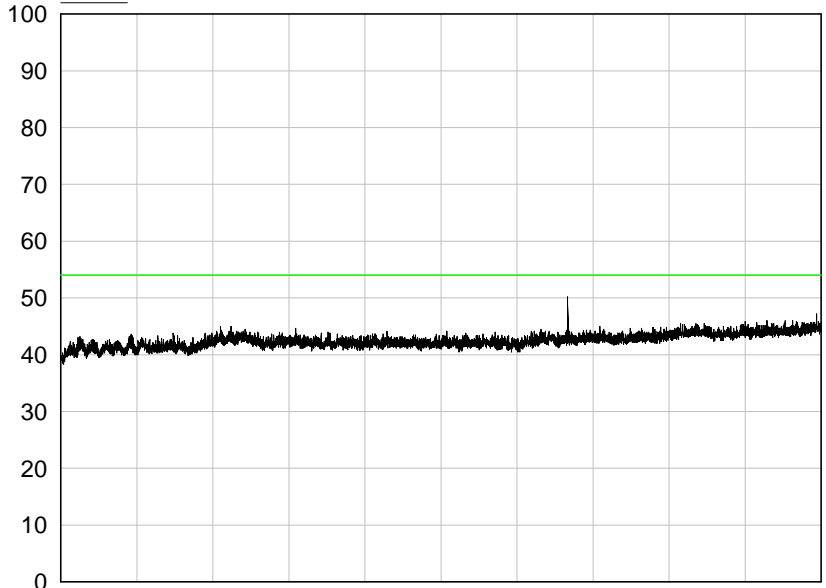

Start: 3.0000 GHz Stop: 6.0000 GHz  
Res BW: 1 MHz Vid BW: 3 MHz Sweep: 500.20 ms  
17/01/2019 14:52:21 E4440A

dB 9927-4 Rad 1 62.64 GHz mcs 0 beam 33 rad em 3-6 GHz vert

(uV/m) Trace A

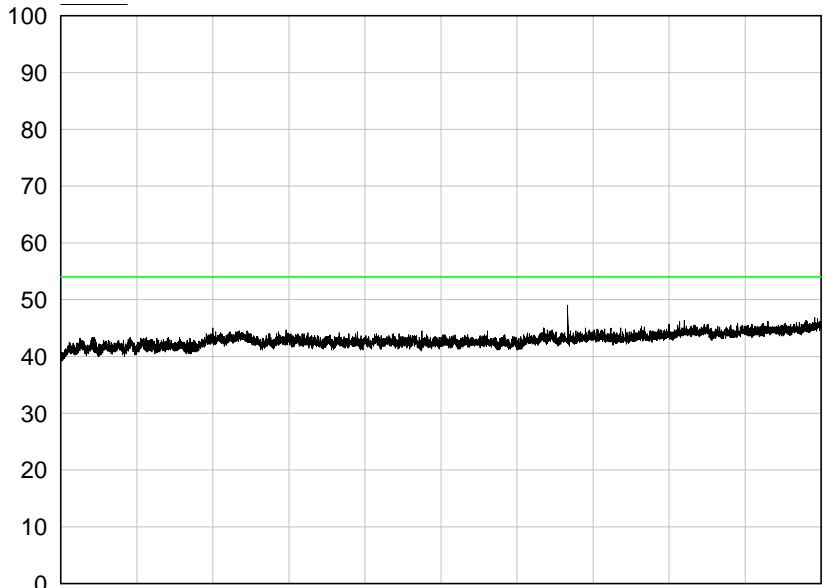

Start: 3.0000 GHz Stop: 6.0000 GHz  
Res BW: 1 MHz Vid BW: 3 MHz Sweep: 500.20 ms  
17/01/2019 14:34:24 E4440A

dB 9927-4 Rad 1 62.64 GHz mcs 0 beam 33 rad em 6-9 GHz horiz

(uV/m) Trace A

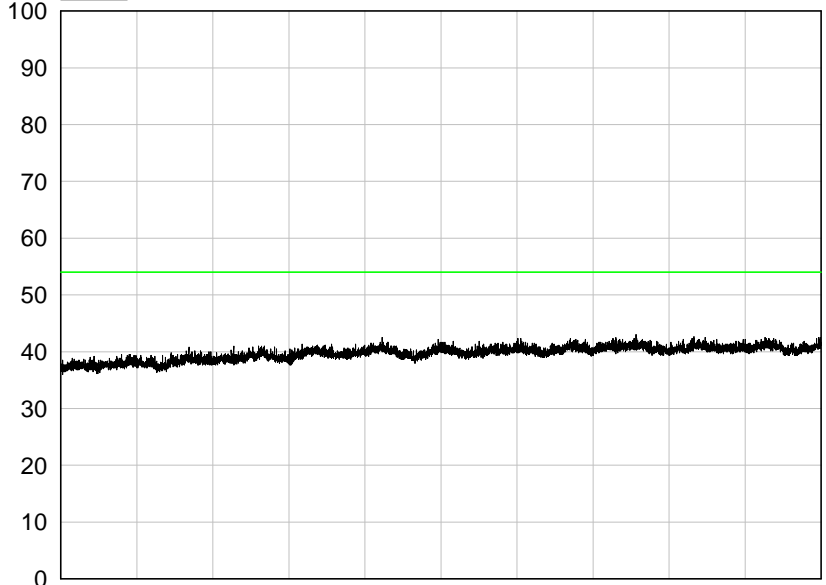

Start: 6.0000 GHz Stop: 9.0000 GHz  
Res BW: 1 MHz Vid BW: 3 MHz Sweep: 500.20 ms  
17/01/2019 14:17:15 E4440A

dB 9927-4 Rad 1 62.64 GHz mcs 0 beam 33 rad em 6-9 GHz vert

(uV/m) Trace A

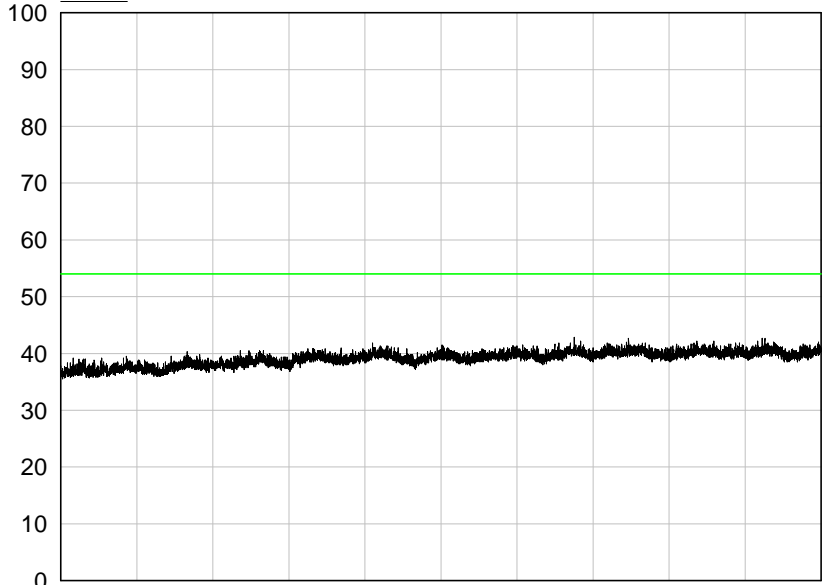

Start: 6.0000 GHz Stop: 9.0000 GHz  
Res BW: 1 MHz Vid BW: 3 MHz Sweep: 500.20 ms  
17/01/2019 14:11:19 E4440A

dB 9927-4 Rad 1 62.64 GHz mcs 0 beam 33 rad em 9-12.5 GHz horiz

(uV/m) Trace A

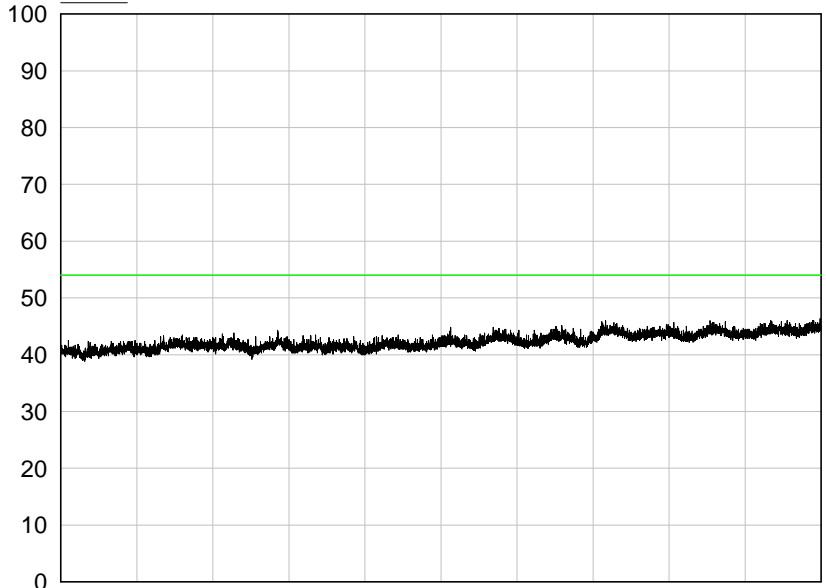

Start: 9.0000 GHz Stop: 12.5000 GHz  
Res BW: 1 MHz Vid BW: 3 MHz Sweep: 500.20 ms  
17/01/2019 14:21:13 E4440A

dB 9927-4 Rad 1 62.64 GHz mcs 0 beam 33 rad em 9-12.5 GHz vert

(uV/m) Trace A

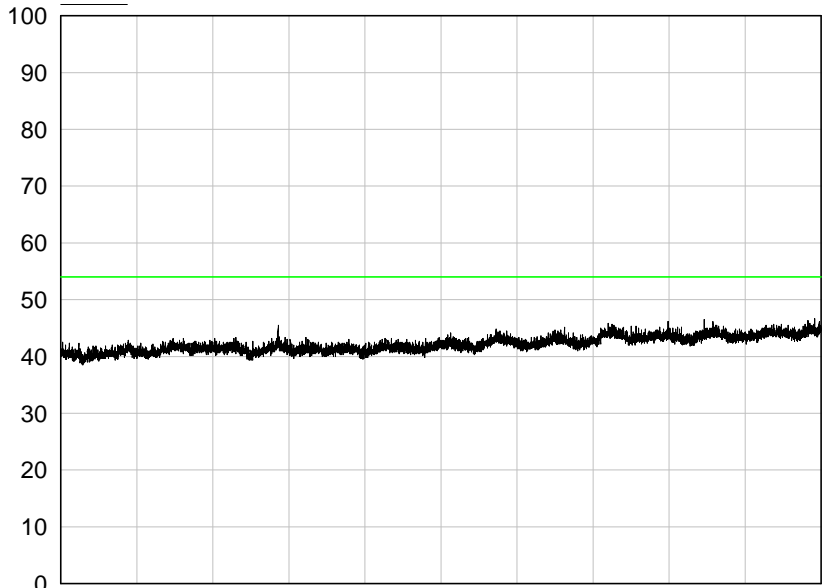

Start: 9.0000 GHz Stop: 12.5000 GHz  
Res BW: 1 MHz Vid BW: 3 MHz Sweep: 500.20 ms  
17/01/2019 14:09:34 E4440A

dB 9927-4 Rad 1 62.64 GHz mcs 0 beam 33 rad em 12.5-15 GHz

(uV/m) Trace A

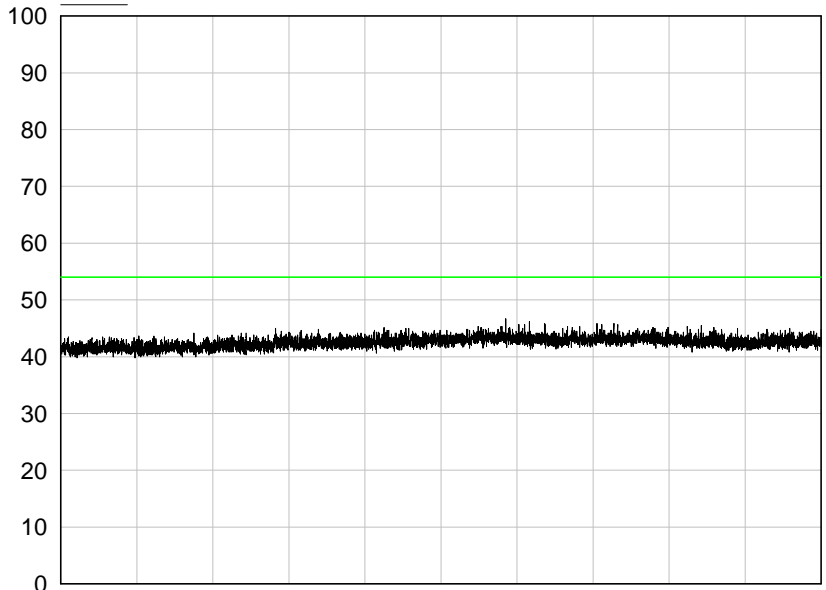

Start: 12.5000 GHz Stop: 15.0000 GHz  
Res BW: 1 MHz Vid BW: 3 MHz Sweep: 5.46 ms  
17/01/2019 09:22:31 E4440A

dB 9927-4 Rad 1 62.64GHz mcs 0 beam 33 rad em 15-18 GHz

(uV/m) Trace A

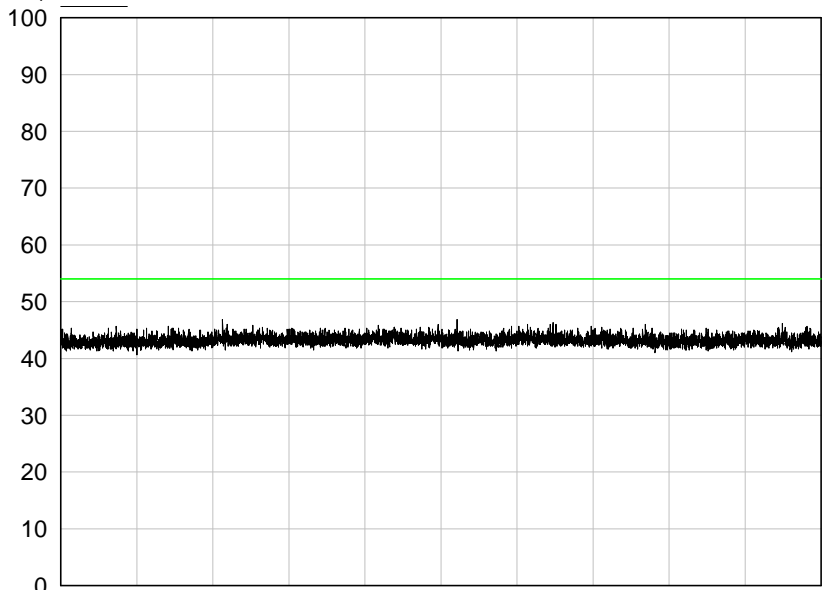

Start: 15.0000 GHz Stop: 18.0000 GHz  
Res BW: 1 MHz Vid BW: 3 MHz Sweep: 6.55 ms  
17/01/2019 09:24:26 E4440A

dB 9927-4 Rad 1 62.64 GHz mcs 0 beam 33 rad em 18-22 GHz

(uV/m) Trace A

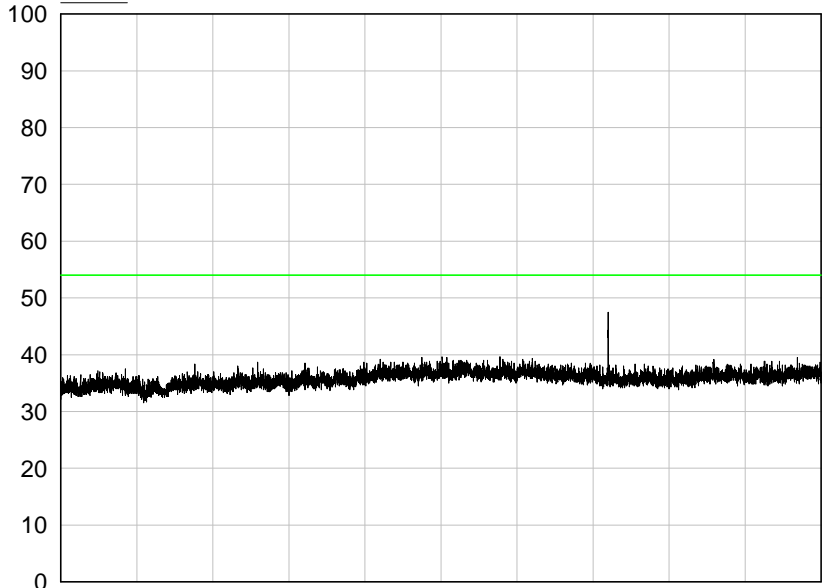

Start: 18.0000 GHz Stop: 22.0000 GHz  
Res BW: 1 MHz Vid BW: 3 MHz Sweep: 10.38 ms  
13/02/2019 16:17:43 E4440A

dB 9927-4 Rad 1 62.64 GHz mcs 0 beam 33 rad em 22-26 GHz

(uV/m) Trace A

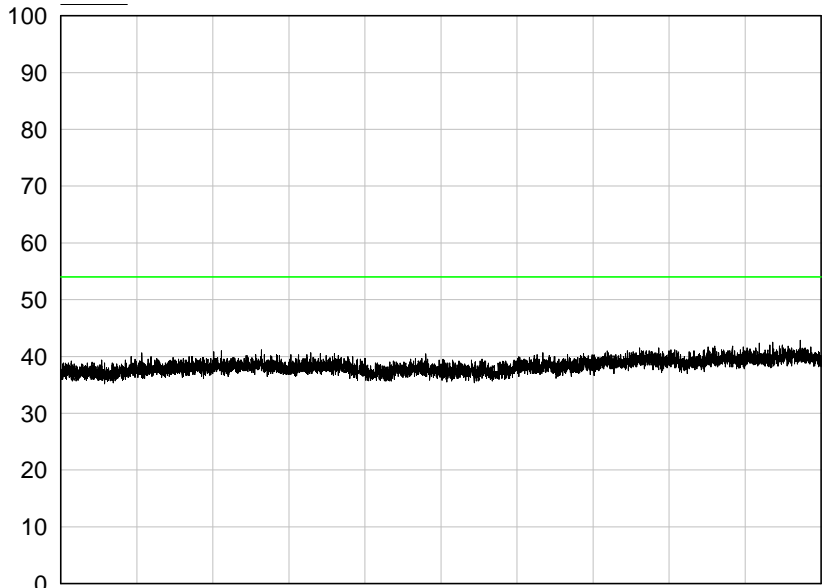

Start: 22.0000 GHz Stop: 26.0000 GHz  
Res BW: 1 MHz Vid BW: 3 MHz Sweep: 10.38 ms  
16/01/2019 15:52:41 E4440A



dB 9927-4 Rad 1 62.64 GHz mcs 0 beam 33 rad em 26-26.5 GHz

(uV/m) Trace A

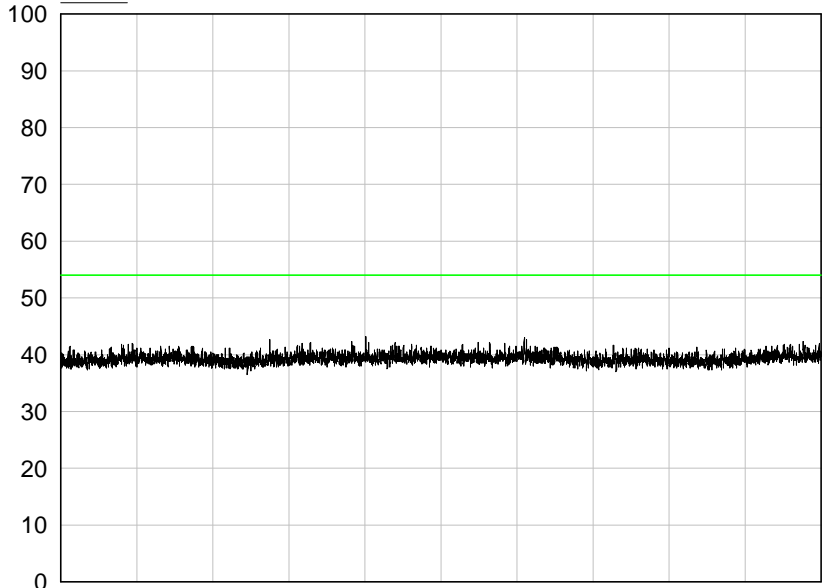

Start: 26.0000 GHz Stop: 26.5000 GHz  
Res BW: 1 MHz Vid BW: 3 MHz Sweep: 1.64 ms  
16/01/2019 15:55:10 E4440A

dB 9927-4 Rad 1 62.64 GHz mcs 0 beam 33 rad em 26.5-30 GHz

(uV/m) Trace A

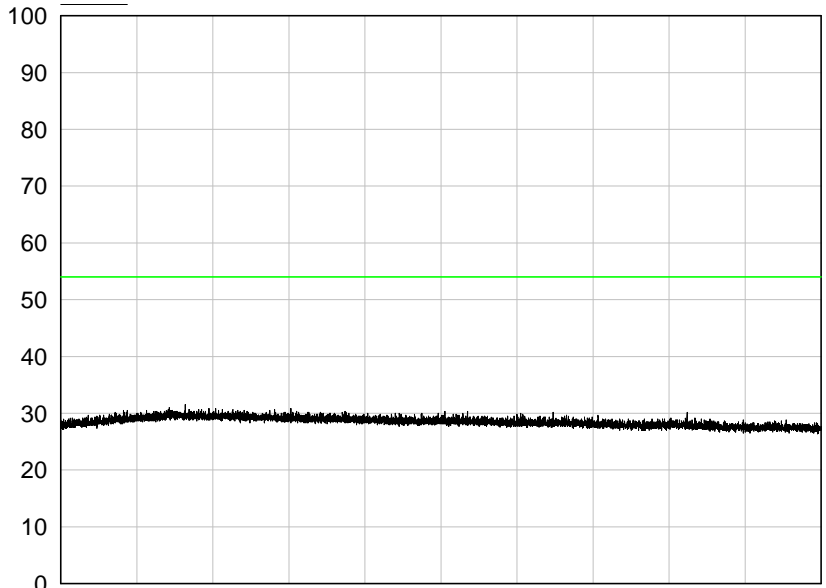

Start: 26.5000 GHz Stop: 30.0000 GHz  
Res BW: 1 MHz Vid BW: 3 MHz Sweep: 87.92 ms  
15/01/2019 16:12:21 E4440A

dB 9927-4 Rad 1 62.64 GHz mcs 0 beam 33 rad em 30-34 GHz

(uV/m) Trace A

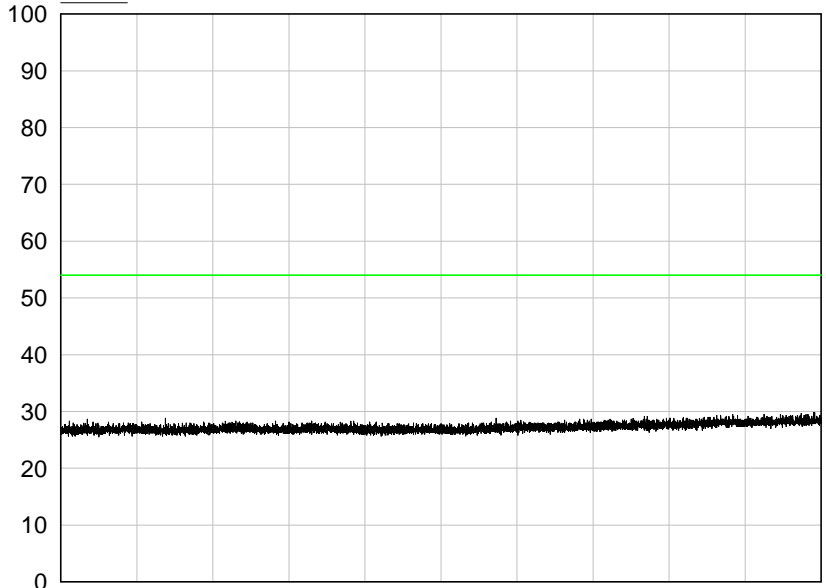

Start: 30.0000 GHz Stop: 34.0000 GHz  
Res BW: 1 MHz Vid BW: 3 MHz Sweep: 100.48 ms  
15/01/2019 16:16:13 E4440A

dB 9927-4 Rad 1 62.64 GHz mcs 0 beam 33 rad em 34-38 GHz

(uV/m) Trace A

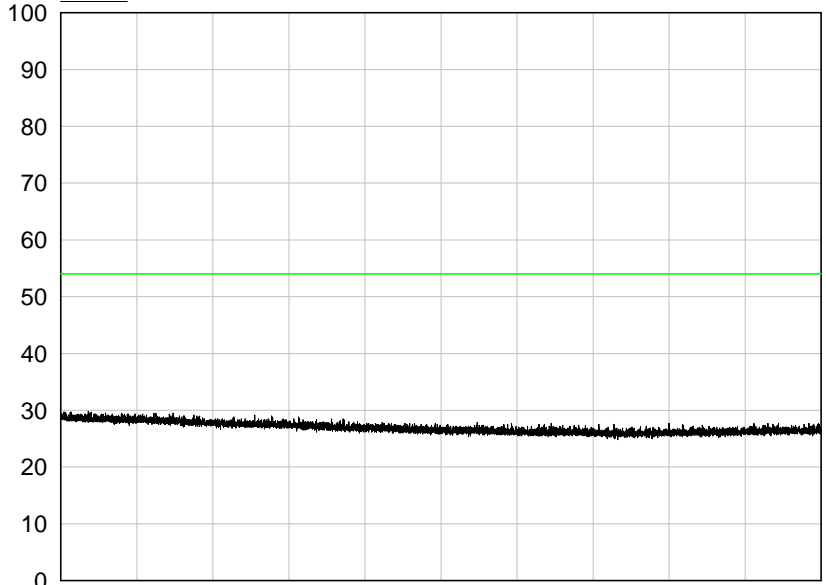

Start: 34.0000 GHz Stop: 38.0000 GHz  
Res BW: 1 MHz Vid BW: 3 MHz Sweep: 100.48 ms  
15/01/2019 16:20:02 E4440A

dB 9927-4 Rad 1 62.64 GHz mcs 0 beam 33 rad em 38-40 GHz

(uV/m) Trace A

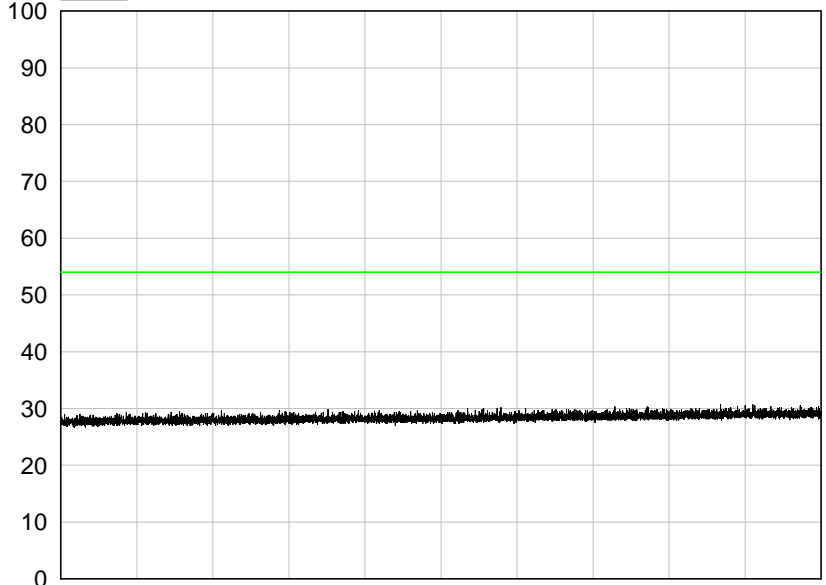

Start: 38.0000 GHz Stop: 40.0000 GHz  
Res BW: 1 MHz Vid BW: 3 MHz Sweep: 50.24 ms  
15/01/2019 16:22:03 E4440A

9927-4 Rad 1 62.64 GHz mcs 0 beam 33 rad em 40-44 GHz

dBuV Trace A

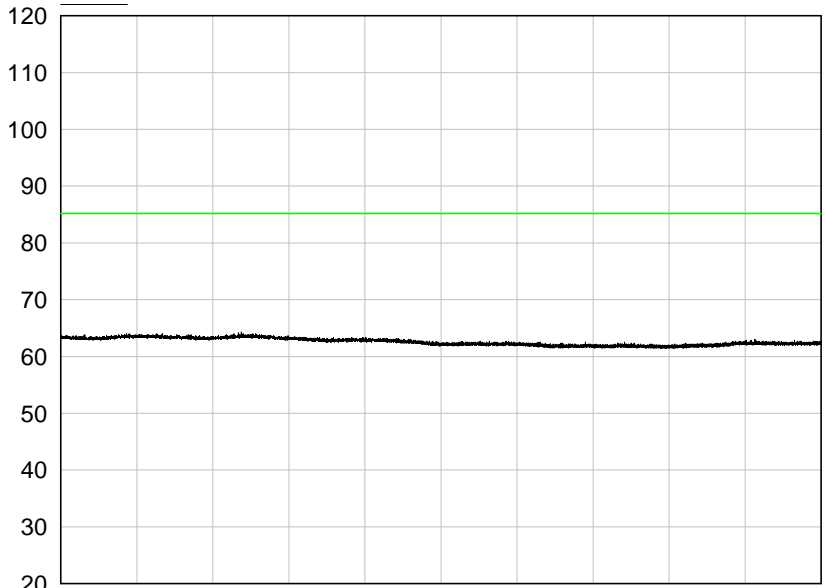

Start: 40.0000 GHz Stop: 44.0000 GHz  
Res BW: 1 MHz Vid BW: 3 MHz Sweep: 1.00 s  
15/01/2019 14:52:13 E4440A

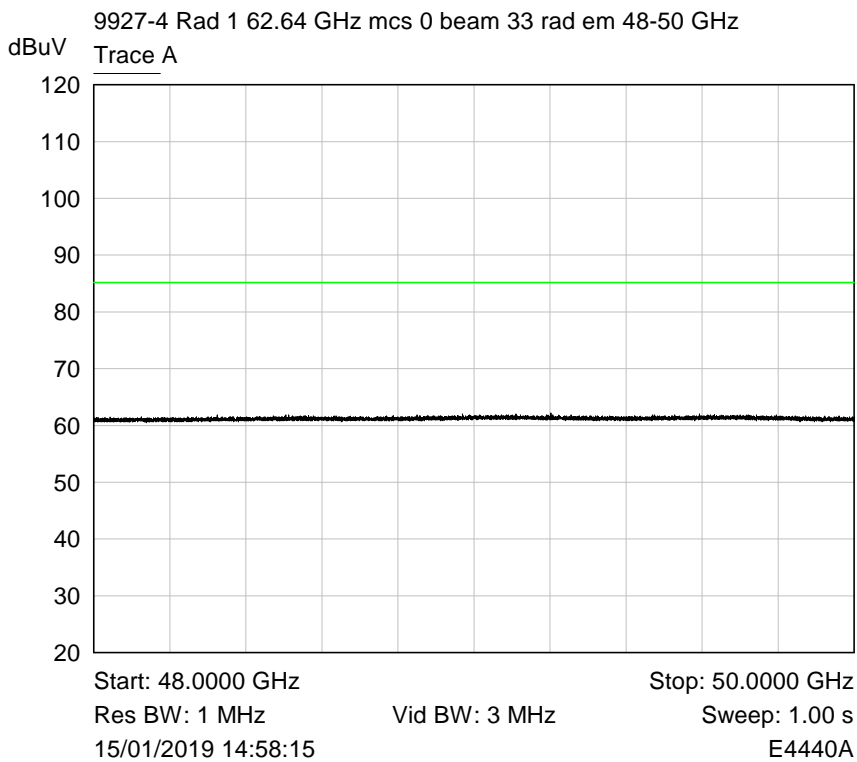
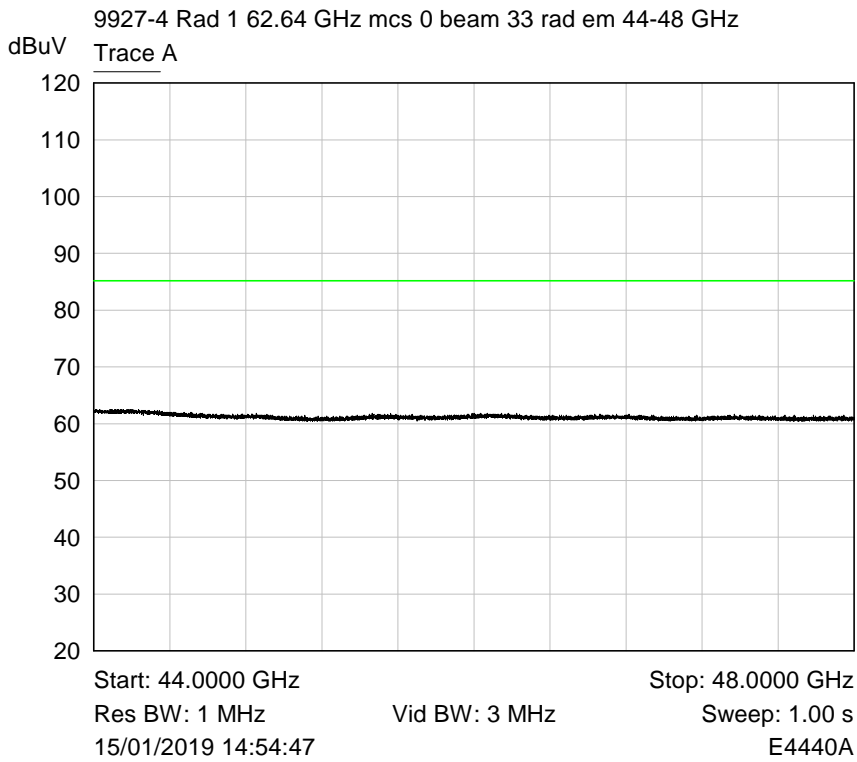

dB 9927-4 Rad 1 62.64 GHz mcs 0 beam 33 rad em 50-54 GHz

(uV/m) Trace A

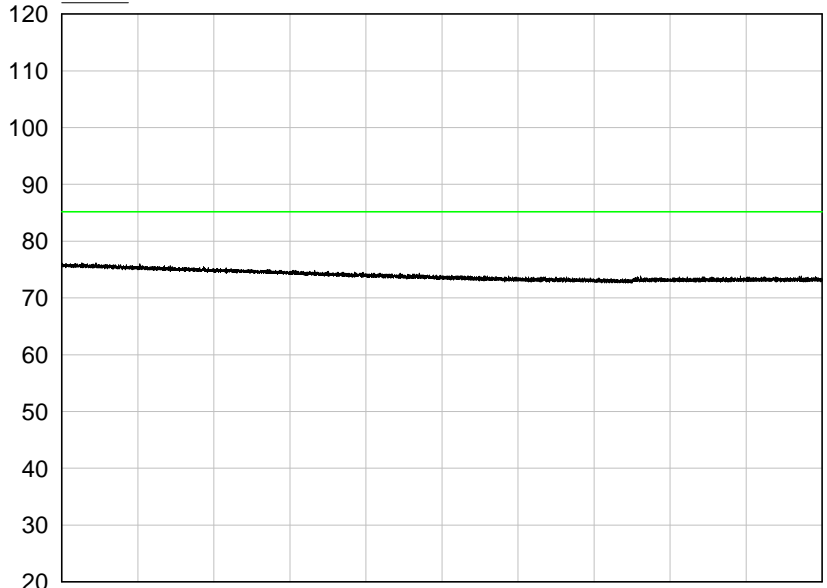

Start: 50.0000 GHz Stop: 54.0000 GHz  
Res BW: 1 MHz Vid BW: 3 MHz Sweep: 1.00 s  
15/01/2019 13:26:16 E4440A

dB 9927-4 Rad 1 62.64 GHz mcs 0 beam 33 rad em 54-58 GHz

(uV/m) Trace A

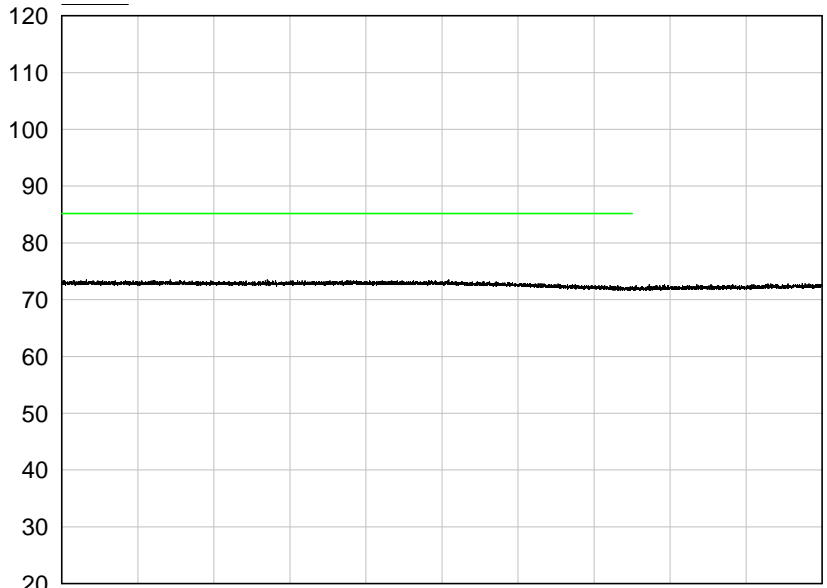

Start: 54.0000 GHz Stop: 58.0000 GHz  
Res BW: 1 MHz Vid BW: 3 MHz Sweep: 1.00 s  
15/01/2019 13:16:24 E4440A

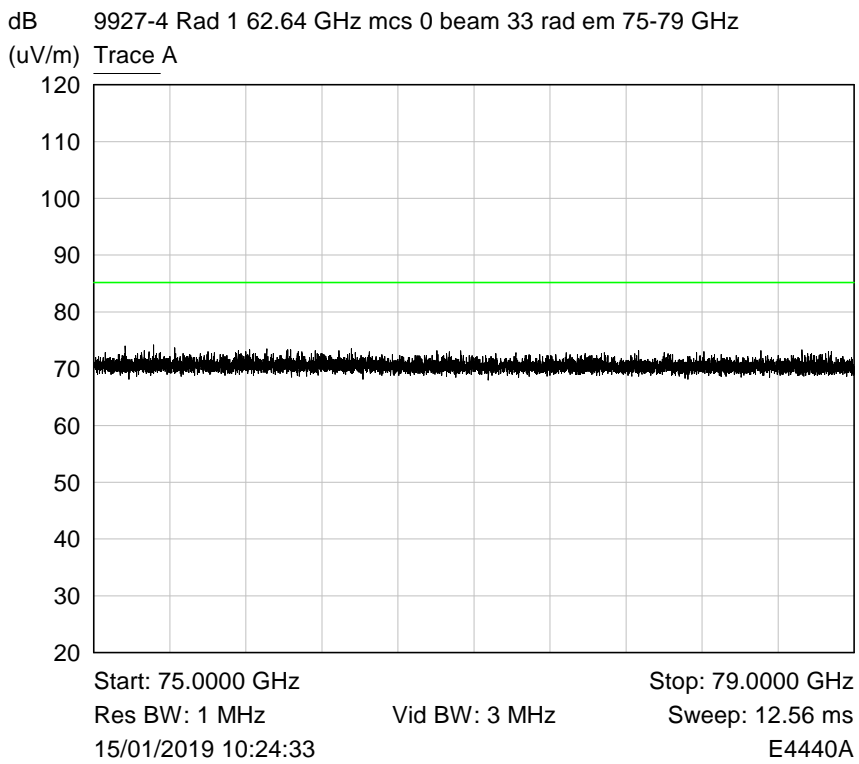
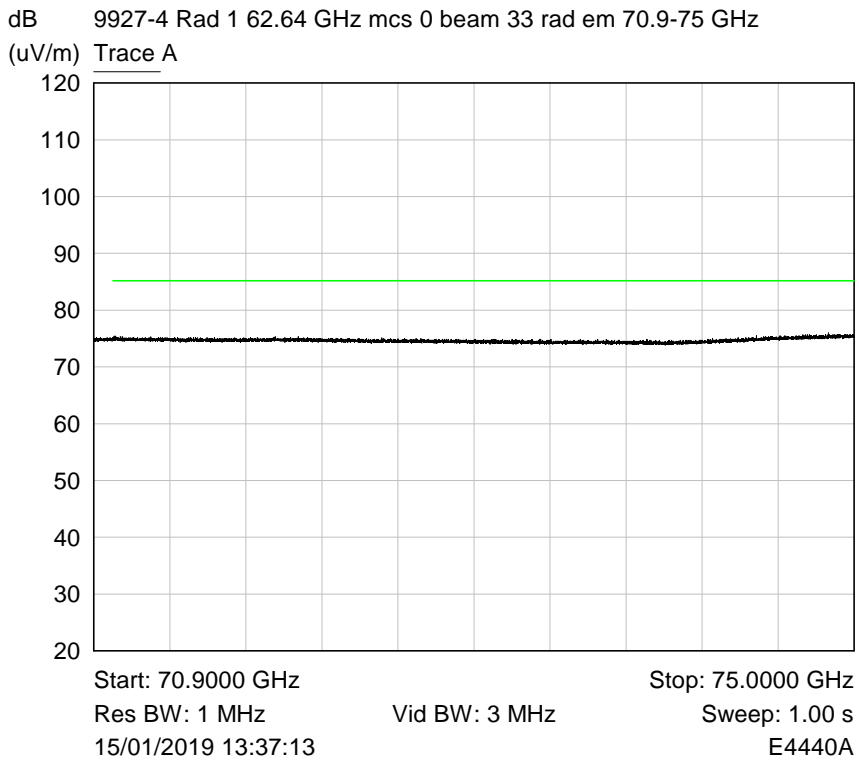

dB 9927-4 Rad 1 62.64 GHz mcs 0 beam 33 rad em 79-83 GHz

(uV/m) Trace A

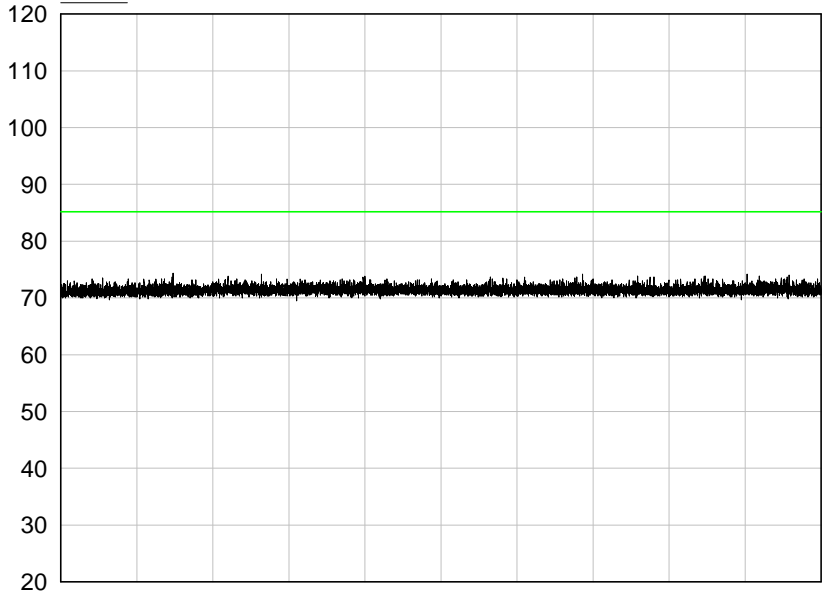

Start: 79.0000 GHz Stop: 83.0000 GHz  
Res BW: 1 MHz Vid BW: 3 MHz Sweep: 12.56 ms  
15/01/2019 10:27:16 E4440A

dB 9927-4 Rad 1 62.64 GHz mcs 0 beam 33 rad em 83-87 GHz

(uV/m) Trace A

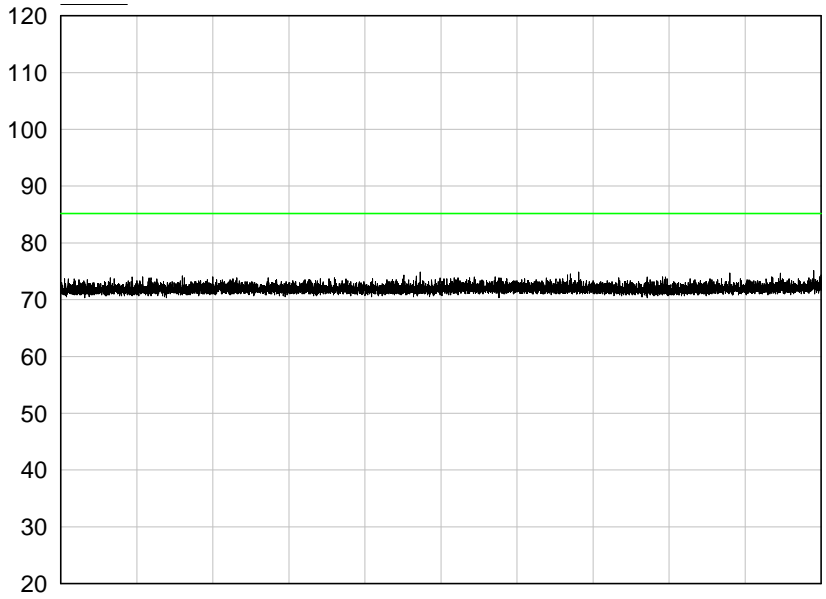

Start: 83.0000 GHz Stop: 87.0000 GHz  
Res BW: 1 MHz Vid BW: 3 MHz Sweep: 12.56 ms  
15/01/2019 10:35:36 E4440A

dB 9927-4 Rad 1 62.64 GHz mcs 0 beam 33 rad em 87-90 GHz

(uV/m) Trace A

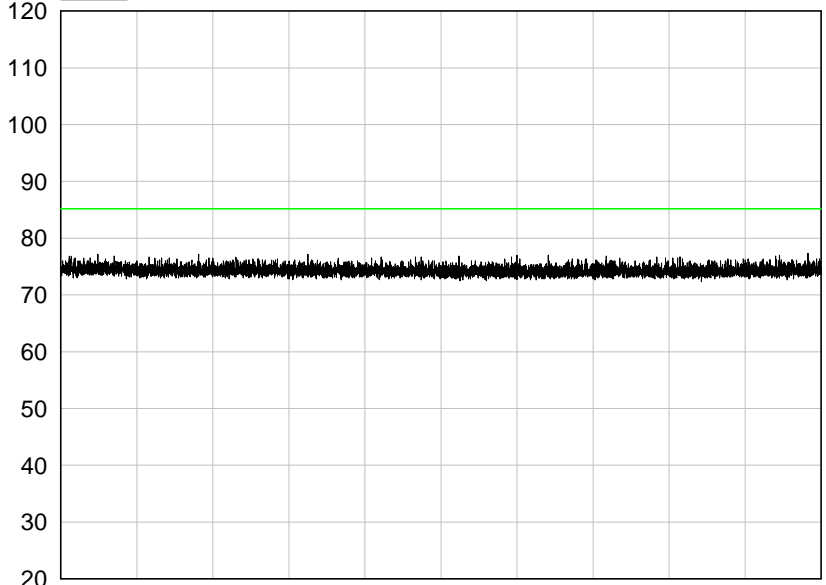

Start: 87.0000 GHz Stop: 90.0000 GHz  
Res BW: 1 MHz Vid BW: 3 MHz Sweep: 9.28 ms  
15/01/2019 10:38:40 E4440A

dB 9927-4 Rad 1 62.64 GHz mcs 0 beam 33 rad em 90-140 GHz

(uV/m) Trace A

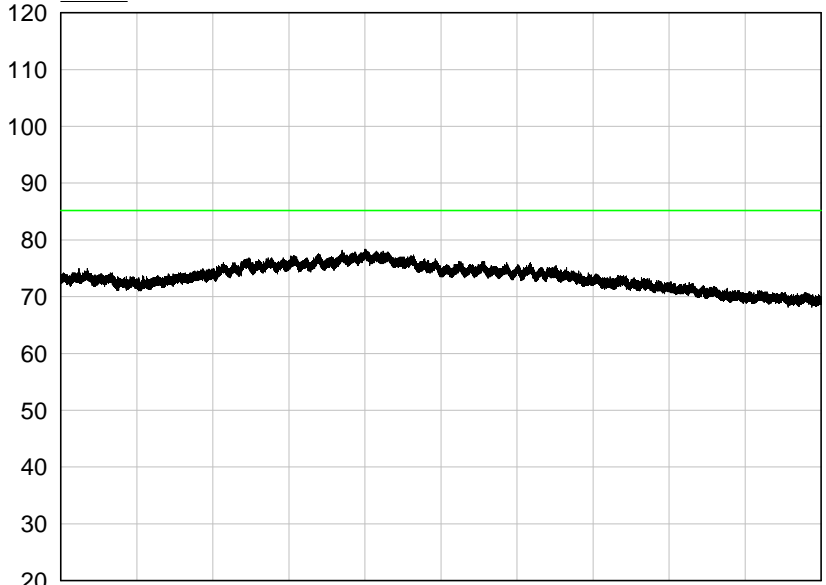

Start: 90.0000 GHz Stop: 140.0000 GHz  
Res BW: 1 MHz Vid BW: 3 MHz Sweep: 2.01 s  
20/12/2018 11:08:04 N9030B



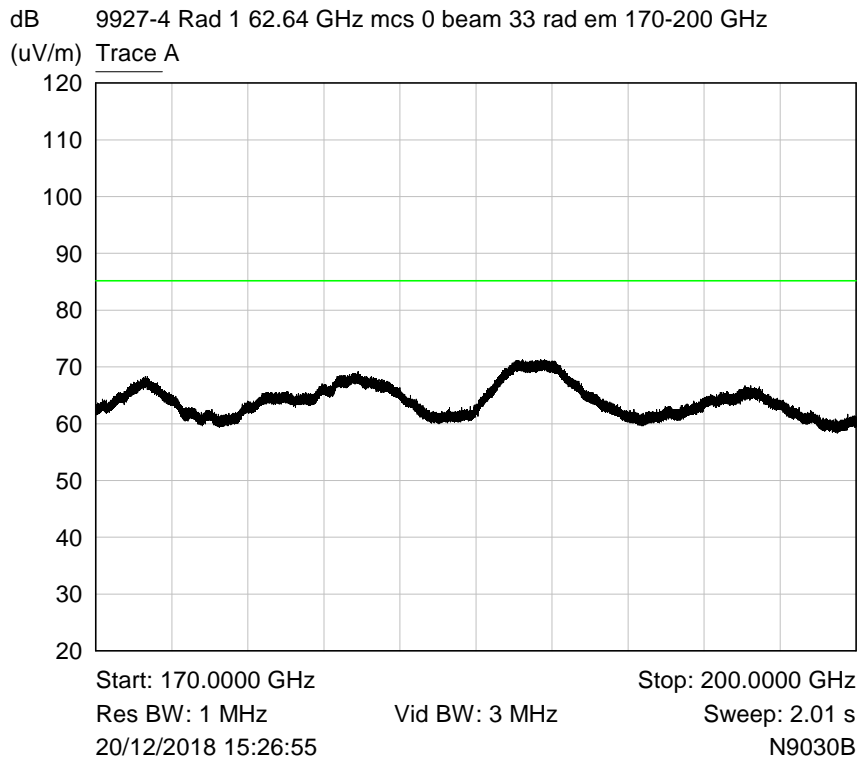

### 6.4 6dB Occupied bandwidth

RF Parameters: Band 57-66 GHz, Power 40 dBm, Channel Spacing 2.16 GHz, Modulation DBPSK (MCS0), Channel 58.32 GHz

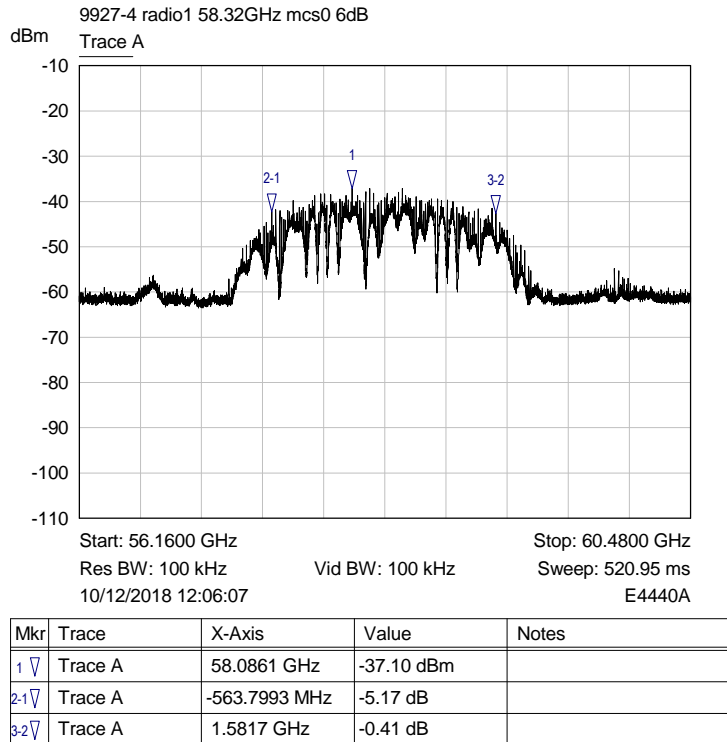

Plot for 6 dB Bandwidth (MHz) Nominal Temp & Volts

RF Parameters: Band 57-66 GHz, Power 40 dBm, Channel Spacing 2.16 GHz, Modulation DBPSK (MCS0), Channel 60.48 GHz

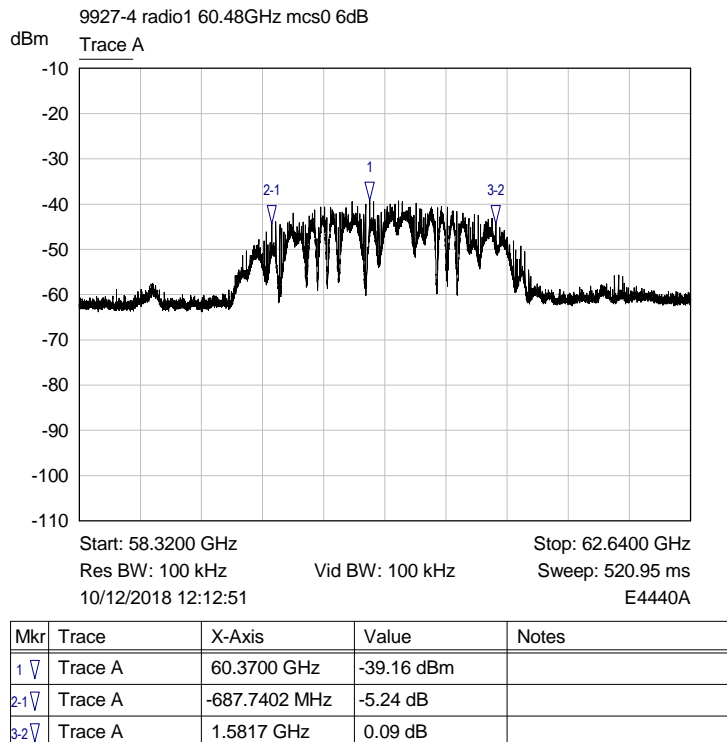

Plot for 6 dB Bandwidth (MHz) Nominal Temp & Volts

RF Parameters: Band 57-66 GHz, Power 40 dBm, Channel Spacing 2.16 GHz, Modulation DBPSK (MCS0), Channel 62.64 GHz

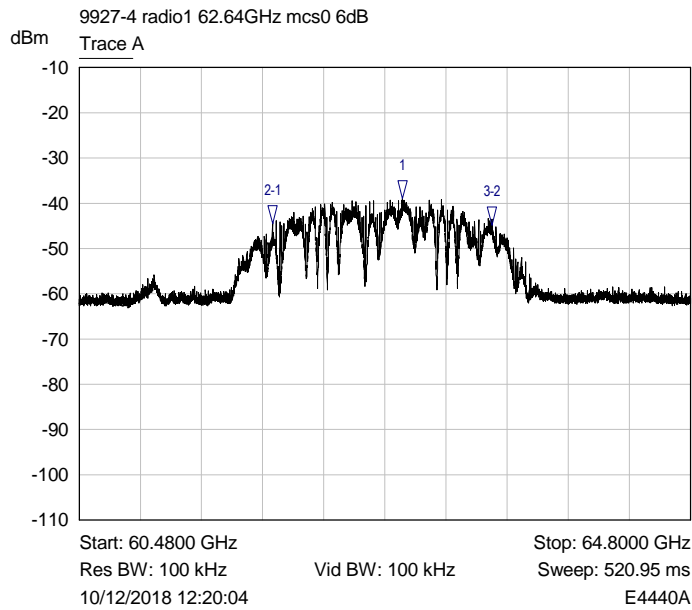

Mkr	Trace	X-Axis	Value	Notes
1 ▽	Trace A	62.7663 GHz	-39.01 dBm	
2-1 ▽	Trace A	-922.4368 MHz	-5.42 dB	
3-2 ▽	Trace A	1.5548 GHz	-0.37 dB	

Plot for 6 dB Bandwidth (MHz) Nominal Temp & Volts

RF Parameters: Band 57-66 GHz, Power 40 dBm, Channel Spacing 2.16 GHz, Modulation DBPSK (MCS0), Channel 64.8 GHz

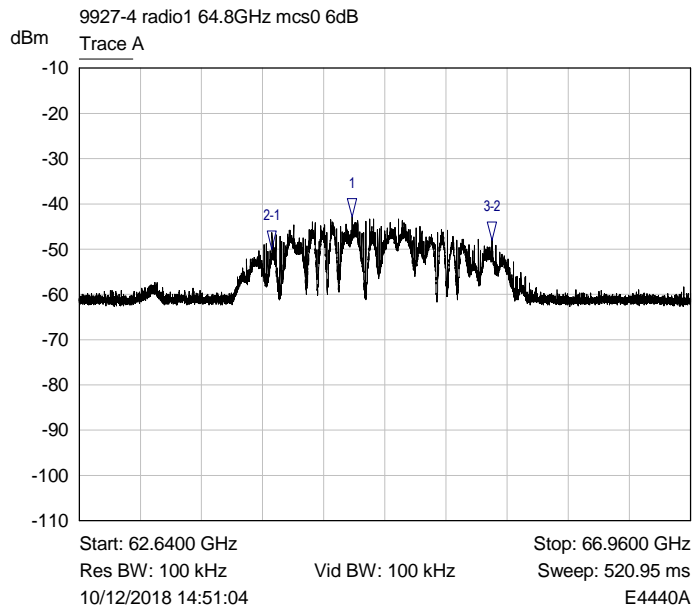

Mkr	Trace	X-Axis	Value	Notes
1 ▽	Trace A	64.5671 GHz	-42.82 dBm	
2-1 ▽	Trace A	-564.3267 MHz	-7.23 dB	
3-2 ▽	Trace A	1.5543 GHz	1.98 dB	

Plot for 6 dB Bandwidth (MHz) Nominal Temp & Volts

RF Parameters: Band 57-66 GHz, Power 40 dBm, Channel Spacing 2.16 GHz, Modulation BPSK (MCS1), Channel 58.32 GHz

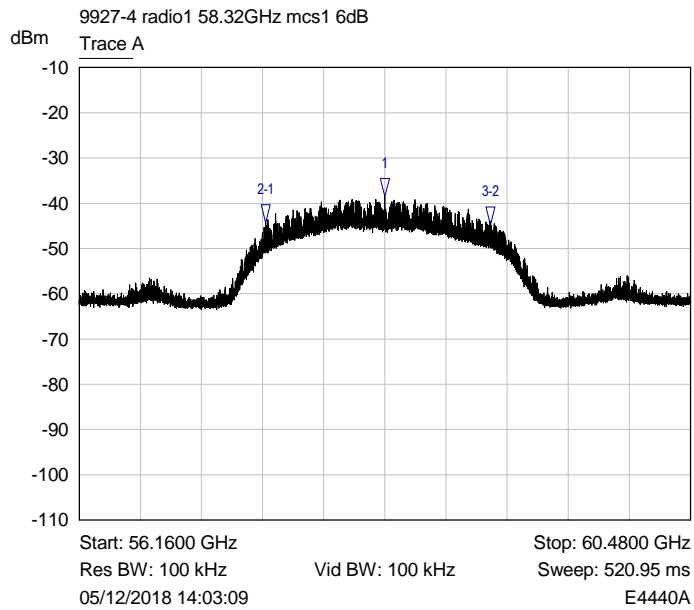

Mkr	Trace	X-Axis	Value	Notes
1	Trace A	58.3197 GHz	-38.51 dBm	
2-1	Trace A	-842.2708 MHz	-5.88 dB	
3-2	Trace A	1.5886 GHz	-0.45 dB	

Plot for 6 dB Bandwidth (MHz) Nominal Temp & Volts

RF Parameters: Band 57-66 GHz, Power 40 dBm, Channel Spacing 2.16 GHz, Modulation BPSK (MCS1), Channel 60.48 GHz

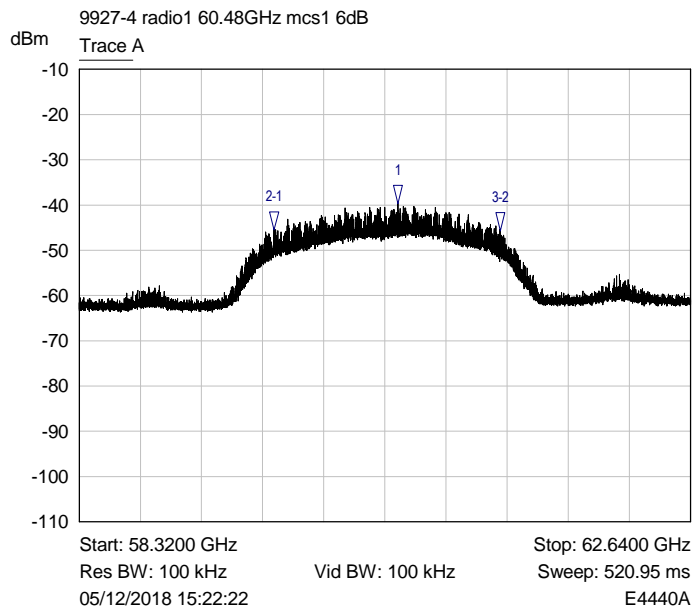

Mkr	Trace	X-Axis	Value	Notes
1	Trace A	60.5726 GHz	-39.73 dBm	
2-1	Trace A	-876.5523 MHz	-5.81 dB	
3-2	Trace A	1.5986 GHz	-0.08 dB	

Plot for 6 dB Bandwidth (MHz) Nominal Temp & Volts

RF Parameters: Band 57-66 GHz, Power 40 dBm, Channel Spacing 2.16 GHz, Modulation BPSK (MCS1), Channel 62.64 GHz

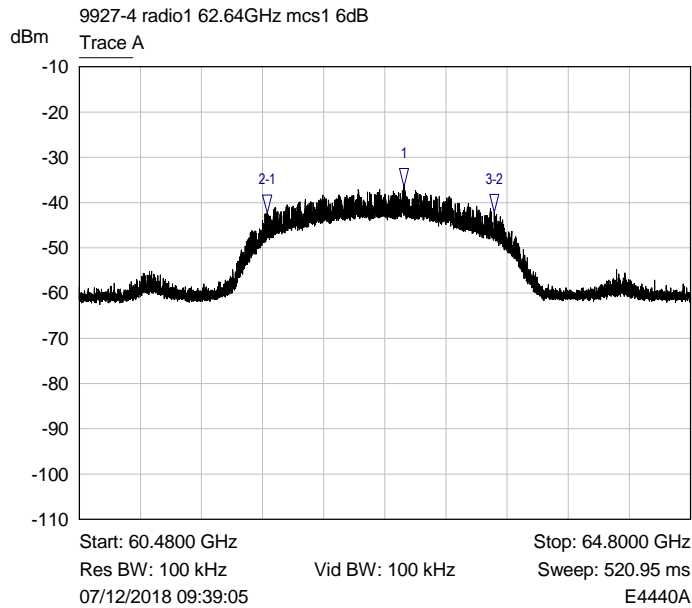

Mkr	Trace	X-Axis	Value	Notes
1 ▽	Trace A	62.7737 GHz	-36.45 dBm	
2-1 ▽	Trace A	-966.2117 MHz	-5.89 dB	
3-2 ▽	Trace A	1.6028 GHz	0.25 dB	

Plot for 6 dB Bandwidth (MHz) Nominal Temp & Volts

RF Parameters: Band 57-66 GHz, Power 40 dBm, Channel Spacing 2.16 GHz, Modulation BPSK (MCS1), Channel 64.8 GHz

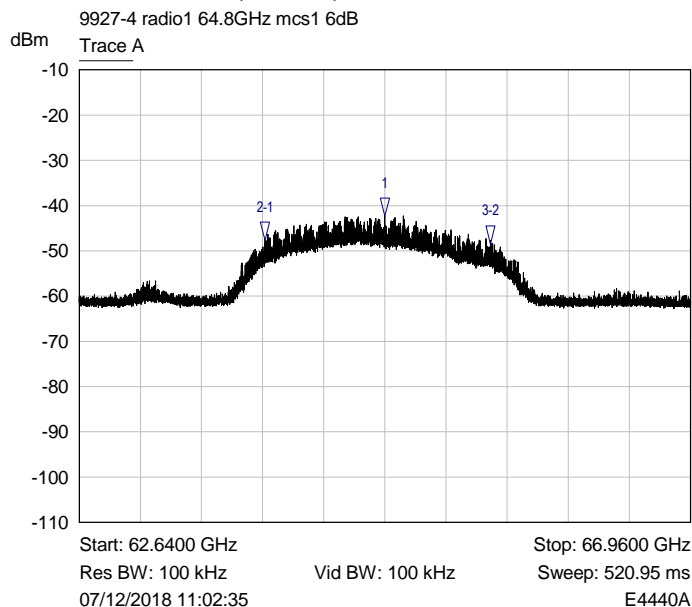

Mkr	Trace	X-Axis	Value	Notes
1 ▽	Trace A	64.7997 GHz	-42.29 dBm	
2-1 ▽	Trace A	-845.9626 MHz	-5.35 dB	
3-2 ▽	Trace A	1.5922 GHz	-0.87 dB	

Plot for 6 dB Bandwidth (MHz) Nominal Temp & Volts

RF Parameters: Band 57-66 GHz, Power 40 dBm, Channel Spacing 2.16 GHz, Modulation BPSK (MCS2), Channel 58.32 GHz

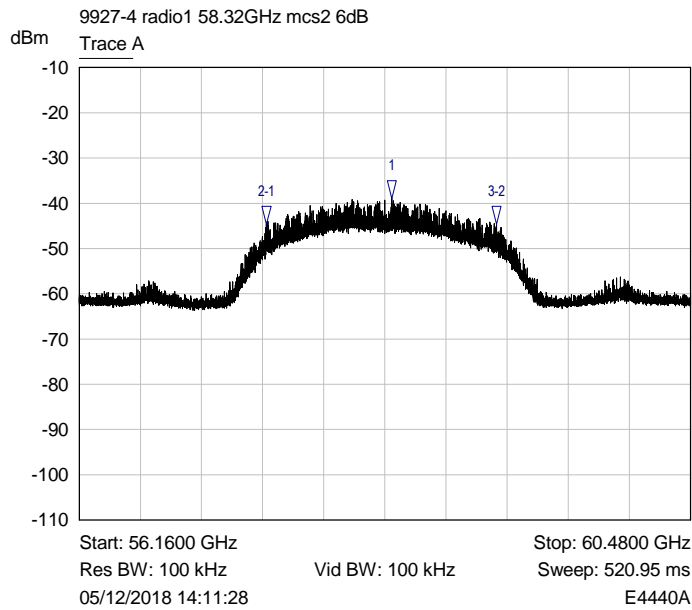

Mkr	Trace	X-Axis	Value	Notes
1 ▽	Trace A	58.3677 GHz	-38.98 dBm	
2-1 ▽	Trace A	-883.4086 MHz	-5.73 dB	
3-2 ▽	Trace A	1.6223 GHz	0.09 dB	

Plot for 6 dB Bandwidth (MHz) Nominal Temp & Volts

RF Parameters: Band 57-66 GHz, Power 40 dBm, Channel Spacing 2.16 GHz, Modulation BPSK (MCS2), Channel 60.48 GHz

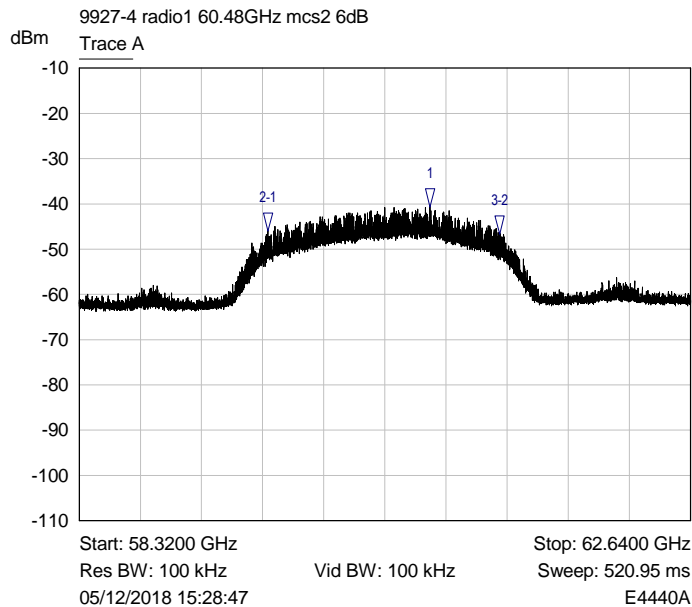

Mkr	Trace	X-Axis	Value	Notes
1 ▽	Trace A	60.7993 GHz	-40.67 dBm	
2-1 ▽	Trace A	-1.1482 GHz	-5.36 dB	
3-2 ▽	Trace A	1.6402 GHz	-0.63 dB	

Plot for 6 dB Bandwidth (MHz) Nominal Temp & Volts

RF Parameters: Band 57-66 GHz, Power 40 dBm, Channel Spacing 2.16 GHz, Modulation BPSK (MCS2), Channel 62.64 GHz

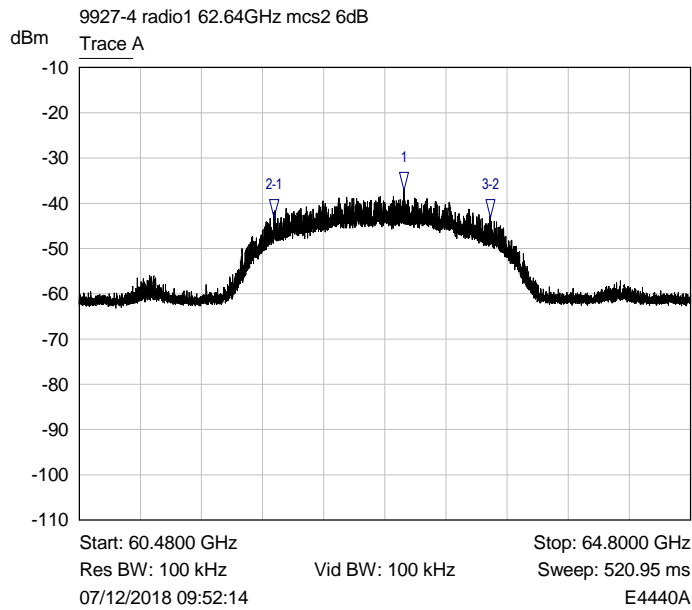

Mkr	Trace	X-Axis	Value	Notes
1 ▽	Trace A	62.7769 GHz	-37.22 dBm	
2-1 ▽	Trace A	-920.3272 MHz	-5.93 dB	
3-2 ▽	Trace A	1.5290 GHz	0.03 dB	

Plot for 6 dB Bandwidth (MHz) Nominal Temp & Volts

RF Parameters: Band 57-66 GHz, Power 40 dBm, Channel Spacing 2.16 GHz, Modulation BPSK (MCS2), Channel 64.8 GHz

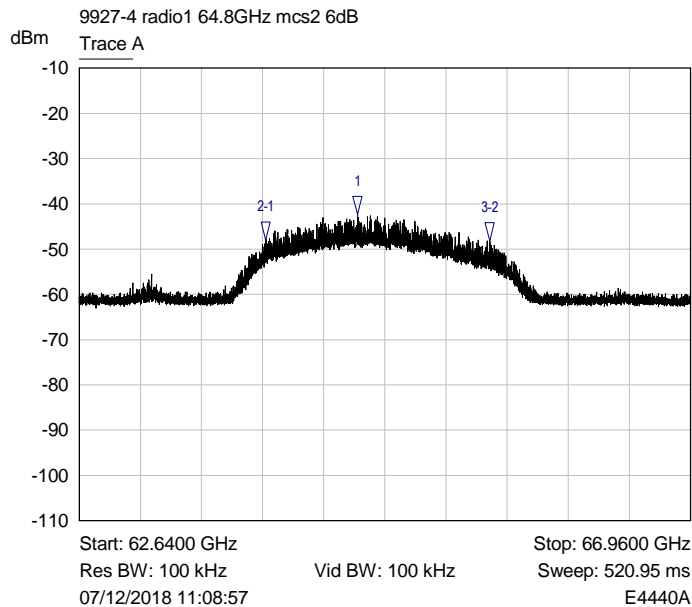

Mkr	Trace	X-Axis	Value	Notes
1 ▽	Trace A	64.6067 GHz	-42.35 dBm	
2-1 ▽	Trace A	-649.2394 MHz	-5.65 dB	
3-2 ▽	Trace A	1.5812 GHz	-0.17 dB	

Plot for 6 dB Bandwidth (MHz) Nominal Temp & Volts

RF Parameters: Band 57-66 GHz, Power 40 dBm, Channel Spacing 2.16 GHz, Modulation BPSK (MCS3), Channel 58.32 GHz

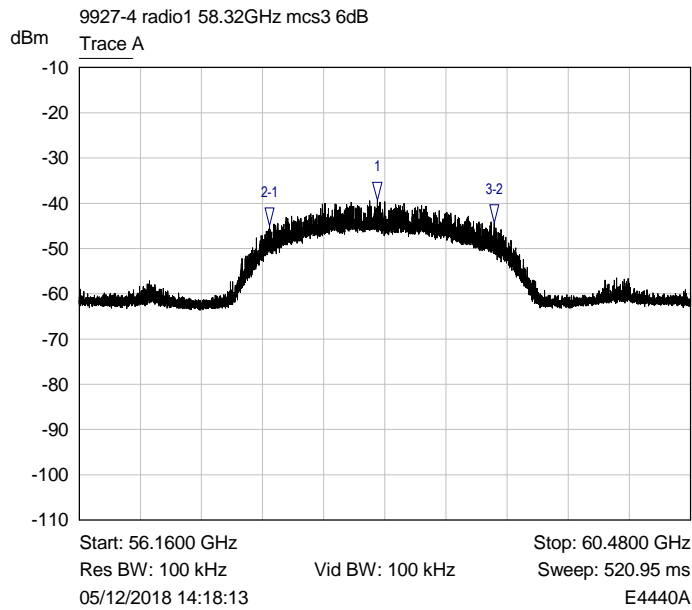

Mkr	Trace	X-Axis	Value	Notes
1	Trace A	58.2681 GHz	-39.28 dBm	
2-1	Trace A	-763.1596 MHz	-5.77 dB	
3-2	Trace A	1.5849 GHz	0.78 dB	

Plot for 6 dB Bandwidth (MHz) Nominal Temp & Volts

RF Parameters: Band 57-66 GHz, Power 40 dBm, Channel Spacing 2.16 GHz, Modulation BPSK (MCS3), Channel 60.48 GHz

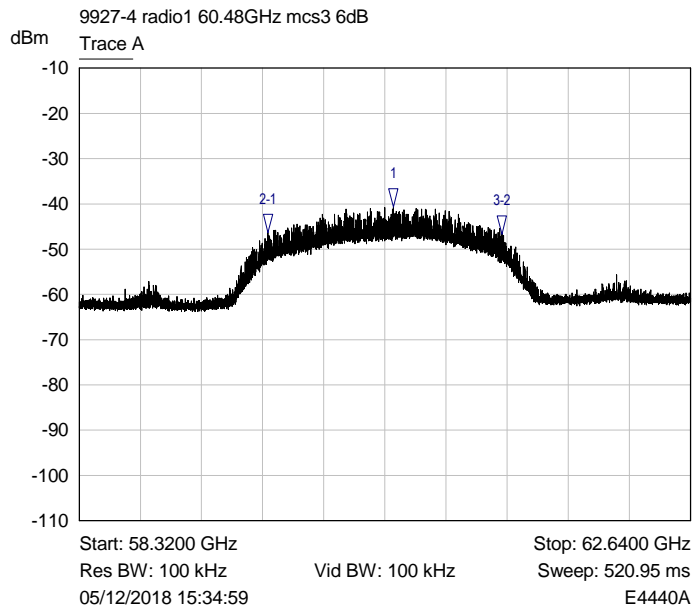

Mkr	Trace	X-Axis	Value	Notes
1	Trace A	60.5383 GHz	-40.75 dBm	
2-1	Trace A	-887.1005 MHz	-5.51 dB	
3-2	Trace A	1.6540 GHz	-0.34 dB	

Plot for 6 dB Bandwidth (MHz) Nominal Temp & Volts



RF Parameters: Band 57-66 GHz, Power 40 dBm, Channel Spacing 2.16 GHz, Modulation BPSK (MCS3), Channel 62.64 GHz

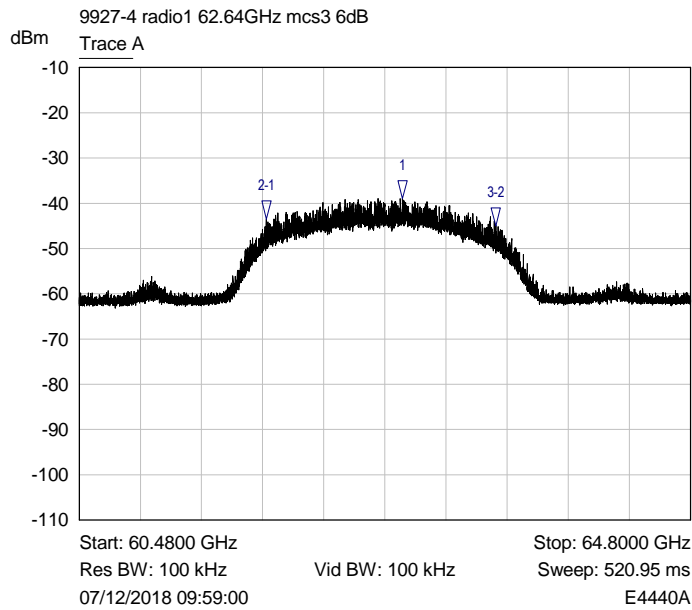

Mkr	Trace	X-Axis	Value	Notes
1 ▾	Trace A	62.7663 GHz	-38.99 dBm	
2-1 ▾	Trace A	-965.6843 MHz	-4.46 dB	
3-2 ▾	Trace A	1.6223 GHz	-1.50 dB	

Plot for 6 dB Bandwidth (MHz) Nominal Temp & Volts

RF Parameters: Band 57-66 GHz, Power 40 dBm, Channel Spacing 2.16 GHz, Modulation BPSK (MCS3), Channel 64.8 GHz

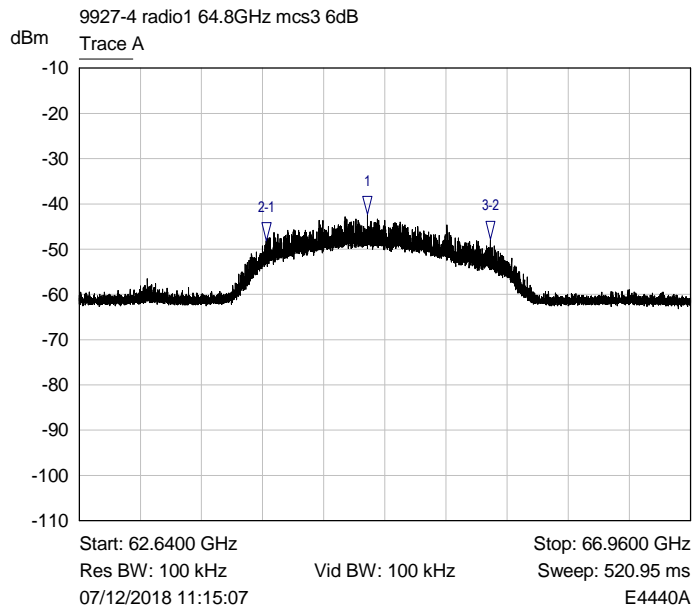

Mkr	Trace	X-Axis	Value	Notes
1 ▾	Trace A	64.6769 GHz	-42.39 dBm	
2-1 ▾	Trace A	-716.2202 MHz	-5.83 dB	
3-2 ▾	Trace A	1.5828 GHz	0.46 dB	

Plot for 6 dB Bandwidth (MHz) Nominal Temp & Volts

RF Parameters: Band 57-66 GHz, Power 40 dBm, Channel Spacing 2.16 GHz, Modulation BPSK (MCS4), Channel 58.32 GHz

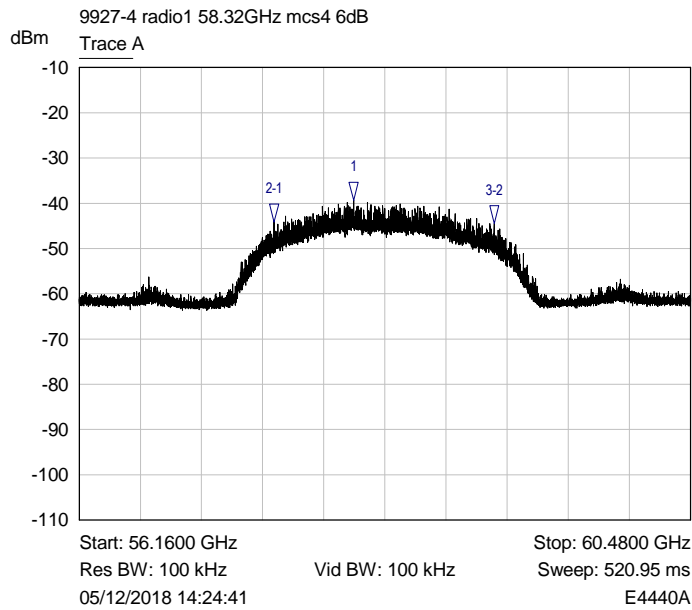

Mkr	Trace	X-Axis	Value	Notes
1 ▽	Trace A	58.0998 GHz	-39.36 dBm	
2-1 ▽	Trace A	-563.7993 MHz	-4.81 dB	
3-2 ▽	Trace A	1.5537 GHz	-0.34 dB	

Plot for 6 dB Bandwidth (MHz) Nominal Temp & Volts

RF Parameters: Band 57-66 GHz, Power 40 dBm, Channel Spacing 2.16 GHz, Modulation BPSK (MCS4), Channel 60.48 GHz

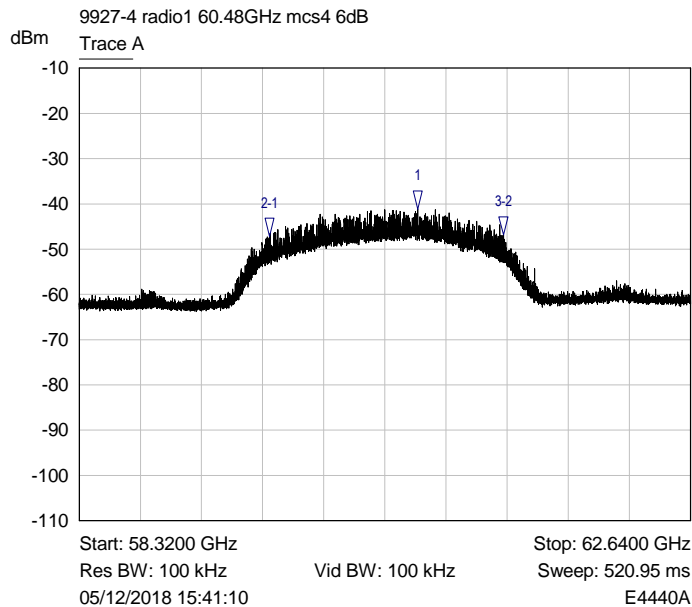

Mkr	Trace	X-Axis	Value	Notes
1 ▽	Trace A	60.7134 GHz	-41.22 dBm	
2-1 ▽	Trace A	-1.0480 GHz	-5.89 dB	
3-2 ▽	Trace A	1.6497 GHz	0.26 dB	

Plot for 6 dB Bandwidth (MHz) Nominal Temp & Volts

RF Parameters: Band 57-66 GHz, Power 40 dBm, Channel Spacing 2.16 GHz, Modulation BPSK (MCS4), Channel 62.64 GHz

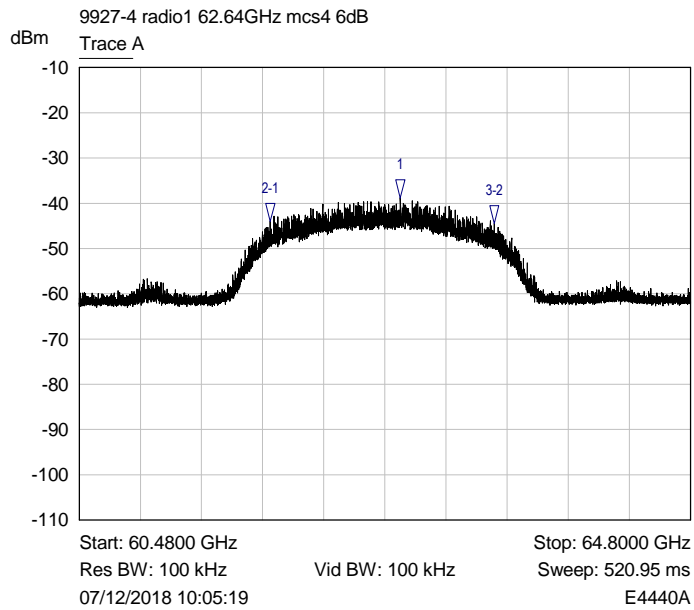

Mkr	Trace	X-Axis	Value	Notes
1 ▽	Trace A	62.7505 GHz	-38.84 dBm	
2-1 ▽	Trace A	-921.3820 MHz	-5.16 dB	
3-2 ▽	Trace A	1.5812 GHz	-0.43 dB	

Plot for 6 dB Bandwidth (MHz) Nominal Temp & Volts

RF Parameters: Band 57-66 GHz, Power 40 dBm, Channel Spacing 2.16 GHz, Modulation BPSK (MCS4), Channel 64.8 GHz

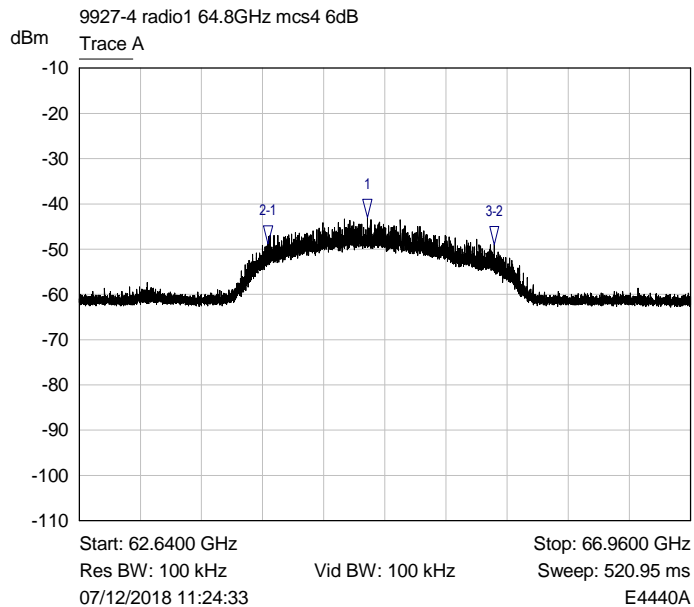

Mkr	Trace	X-Axis	Value	Notes
1 ▽	Trace A	64.6769 GHz	-42.96 dBm	
2-1 ▽	Trace A	-705.6721 MHz	-5.95 dB	
3-2 ▽	Trace A	1.5991 GHz	-0.01 dB	

Plot for 6 dB Bandwidth (MHz) Nominal Temp & Volts

RF Parameters: Band 57-66 GHz, Power 40 dBm, Channel Spacing 2.16 GHz, Modulation BPSK (MCS5), Channel 58.32 GHz

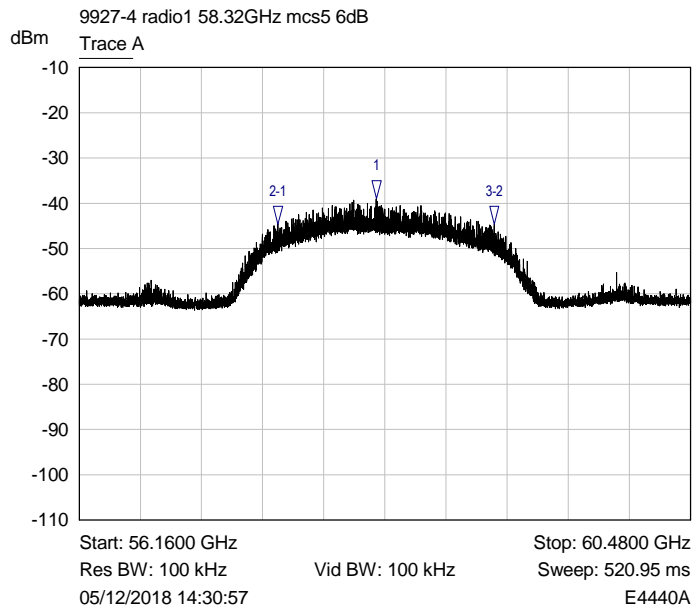

Mkr	Trace	X-Axis	Value	Notes
1	Trace A	58.2580 GHz	-38.98 dBm	
2-1	Trace A	-694.5965 MHz	-5.64 dB	
3-2	Trace A	1.5263 GHz	-0.02 dB	

Plot for 6 dB Bandwidth (MHz) Nominal Temp & Volts

RF Parameters: Band 57-66 GHz, Power 40 dBm, Channel Spacing 2.16 GHz, Modulation BPSK (MCS5), Channel 60.48 GHz

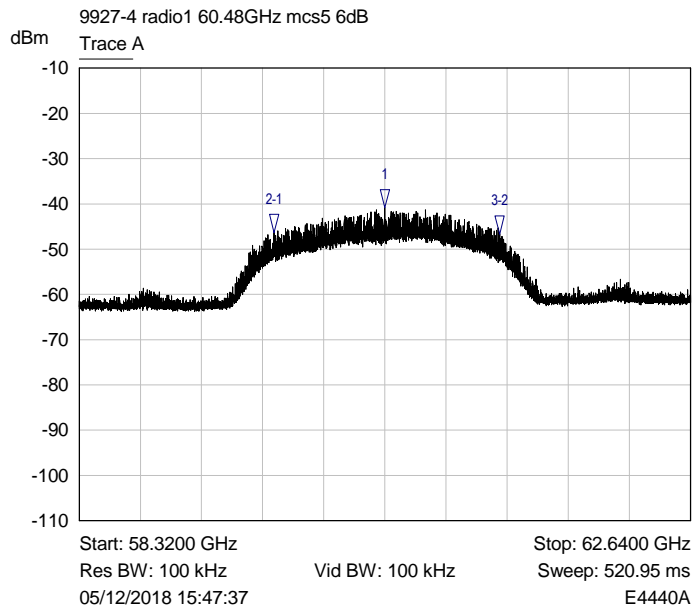

Mkr	Trace	X-Axis	Value	Notes
1	Trace A	60.4797 GHz	-40.82 dBm	
2-1	Trace A	-783.7285 MHz	-5.59 dB	
3-2	Trace A	1.5949 GHz	-0.23 dB	

Plot for 6 dB Bandwidth (MHz) Nominal Temp & Volts

RF Parameters: Band 57-66 GHz, Power 40 dBm, Channel Spacing 2.16 GHz, Modulation BPSK (MCS5), Channel 62.64 GHz

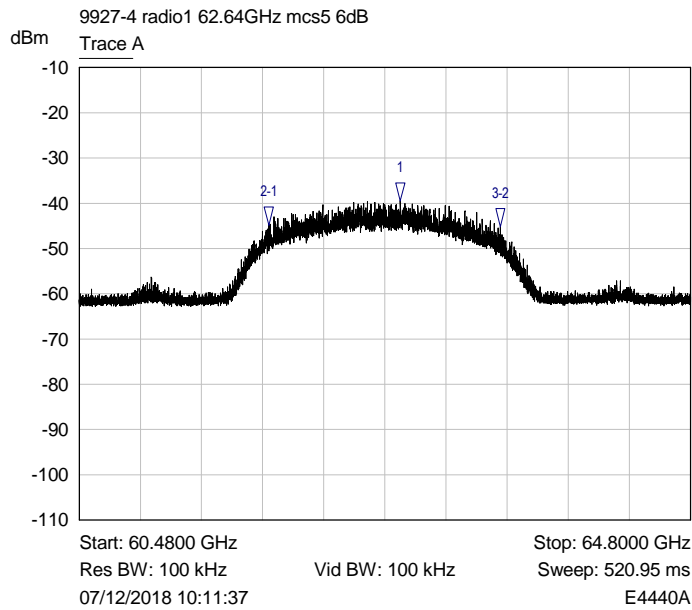

Mkr	Trace	X-Axis	Value	Notes
1	Trace A	62.7505 GHz	-39.45 dBm	
2-1	Trace A	-929.2931 MHz	-5.37 dB	
3-2	Trace A	1.6329 GHz	-0.27 dB	

Plot for 6 dB Bandwidth (MHz) Nominal Temp & Volts

RF Parameters: Band 57-66 GHz, Power 40 dBm, Channel Spacing 2.16 GHz, Modulation BPSK (MCS5), Channel 64.8 GHz

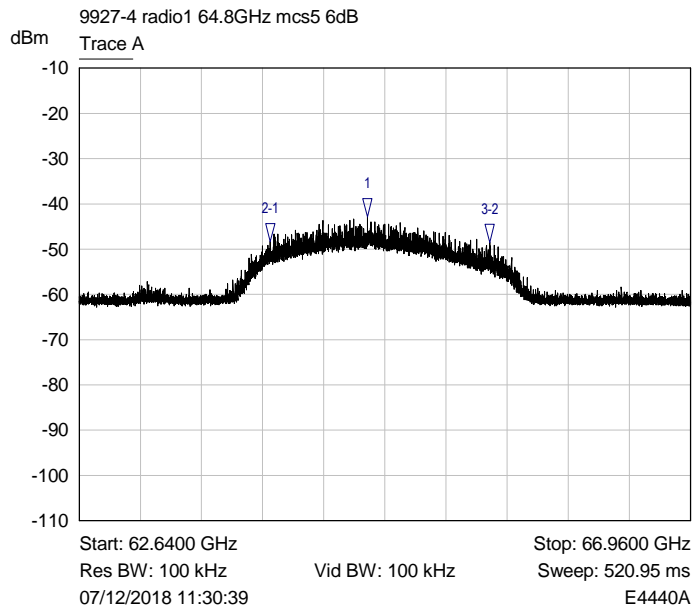

Mkr	Trace	X-Axis	Value	Notes
1	Trace A	64.6769 GHz	-42.82 dBm	
2-1	Trace A	-687.7402 MHz	-5.57 dB	
3-2	Trace A	1.5501 GHz	-0.18 dB	

Plot for 6 dB Bandwidth (MHz) Nominal Temp & Volts

RF Parameters: Band 57-66 GHz, Power 40 dBm, Channel Spacing 2.16 GHz, Modulation QPSK (MCS6), Channel 58.32 GHz

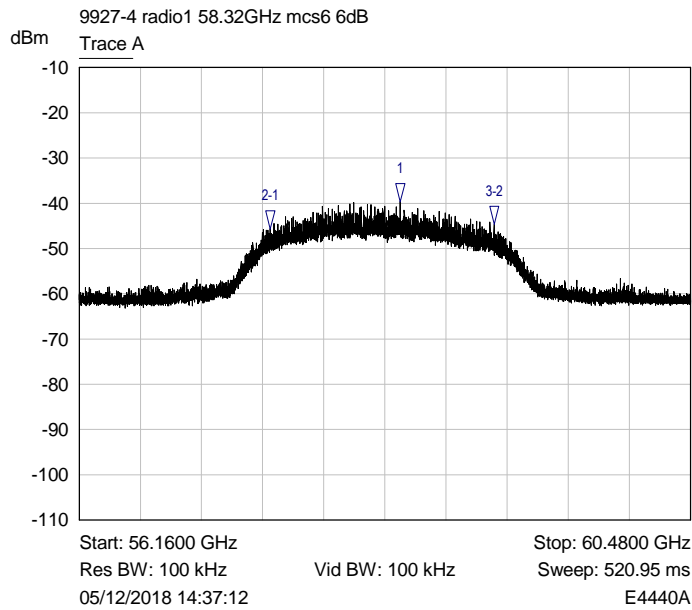

Mkr	Trace	X-Axis	Value	Notes
1	Trace A	58.4300 GHz	-39.67 dBm	
2-1	Trace A	-921.3820 MHz	-5.92 dB	
3-2	Trace A	1.5812 GHz	0.97 dB	

Plot for 6 dB Bandwidth (MHz) Nominal Temp & Volts

RF Parameters: Band 57-66 GHz, Power 40 dBm, Channel Spacing 2.16 GHz, Modulation QPSK (MCS6), Channel 60.48 GHz

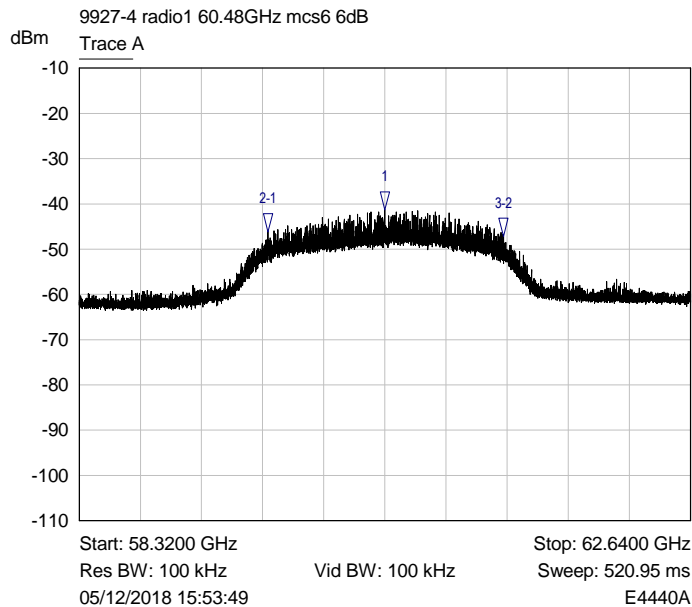

Mkr	Trace	X-Axis	Value	Notes
1	Trace A	60.4797 GHz	-41.27 dBm	
2-1	Trace A	-824.8663 MHz	-4.96 dB	
3-2	Trace A	1.6640 GHz	-0.88 dB	

Plot for 6 dB Bandwidth (MHz) Nominal Temp & Volts

RF Parameters: Band 57-66 GHz, Power 40 dBm, Channel Spacing 2.16 GHz, Modulation QPSK (MCS6), Channel 62.64 GHz

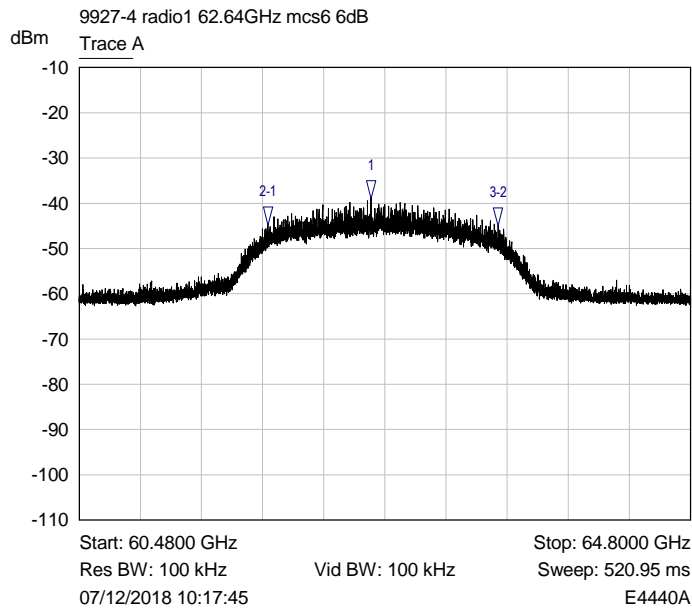

Mkr	Trace	X-Axis	Value	Notes
1 ▽	Trace A	62.5443 GHz	-39.06 dBm	
2-1 ▽	Trace A	-728.8780 MHz	-5.77 dB	
3-2 ▽	Trace A	1.6223 GHz	-0.22 dB	

Plot for 6 dB Bandwidth (MHz) Nominal Temp & Volts

RF Parameters: Band 57-66 GHz, Power 40 dBm, Channel Spacing 2.16 GHz, Modulation QPSK (MCS6), Channel 64.8 GHz

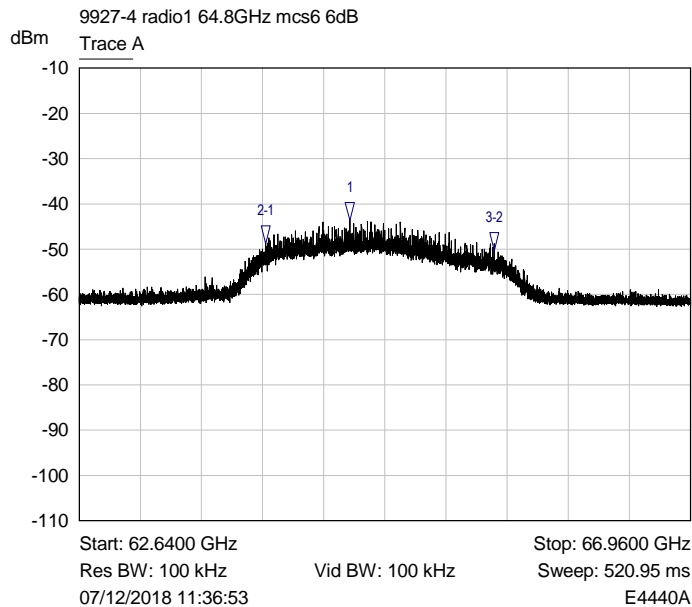

Mkr	Trace	X-Axis	Value	Notes
1 ▽	Trace A	64.5529 GHz	-43.67 dBm	
2-1 ▽	Trace A	-595.4438 MHz	-5.23 dB	
3-2 ▽	Trace A	1.6133 GHz	-1.45 dB	

Plot for 6 dB Bandwidth (MHz) Nominal Temp & Volts

RF Parameters: Band 57-66 GHz, Power 40 dBm, Channel Spacing 2.16 GHz, Modulation QPSK (MCS7), Channel 58.32 GHz

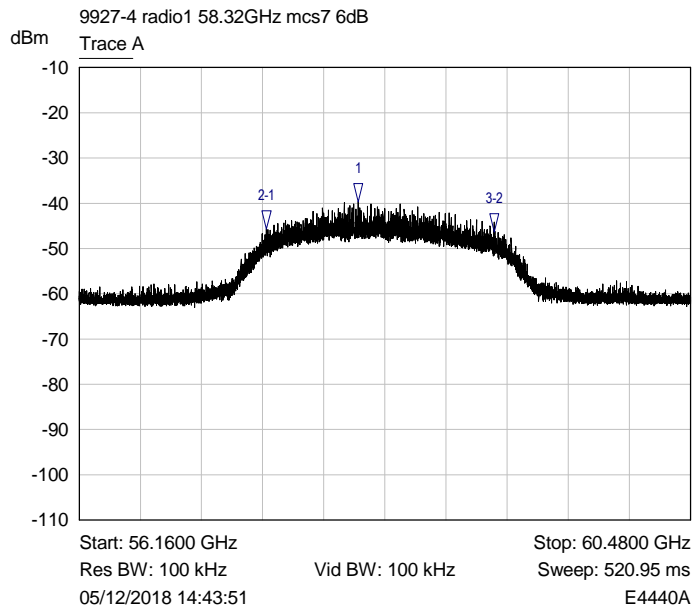

Mkr	Trace	X-Axis	Value	Notes
1	Trace A	58.1309 GHz	-39.69 dBm	
2-1	Trace A	-649.2394 MHz	-5.95 dB	
3-2	Trace A	1.6086 GHz	-0.64 dB	

Plot for 6 dB Bandwidth (MHz) Nominal Temp & Volts

RF Parameters: Band 57-66 GHz, Power 40 dBm, Channel Spacing 2.16 GHz, Modulation QPSK (MCS7), Channel 60.48 GHz

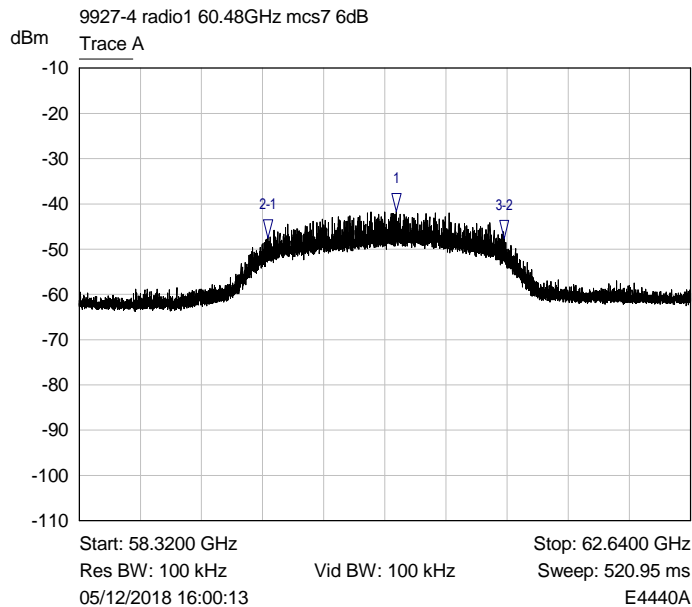

Mkr	Trace	X-Axis	Value	Notes
1	Trace A	60.5625 GHz	-41.62 dBm	
2-1	Trace A	-907.6694 MHz	-5.85 dB	
3-2	Trace A	1.6671 GHz	-0.13 dB	

Plot for 6 dB Bandwidth (MHz) Nominal Temp & Volts



RF Parameters: Band 57-66 GHz, Power 40 dBm, Channel Spacing 2.16 GHz, Modulation QPSK (MCS7), Channel 62.64 GHz

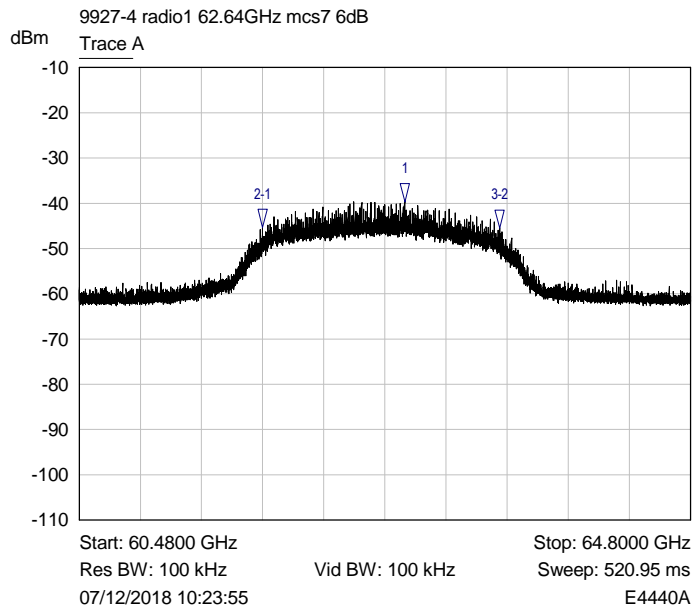

Mkr	Trace	X-Axis	Value	Notes
1 ▽	Trace A	62.7779 GHz	-39.65 dBm	
2-1 ▽	Trace A	-1.0037 GHz	-5.64 dB	
3-2 ▽	Trace A	1.6777 GHz	-0.16 dB	

Plot for 6 dB Bandwidth (MHz) Nominal Temp & Volts

RF Parameters: Band 57-66 GHz, Power 40 dBm, Channel Spacing 2.16 GHz, Modulation QPSK (MCS7), Channel 64.8 GHz

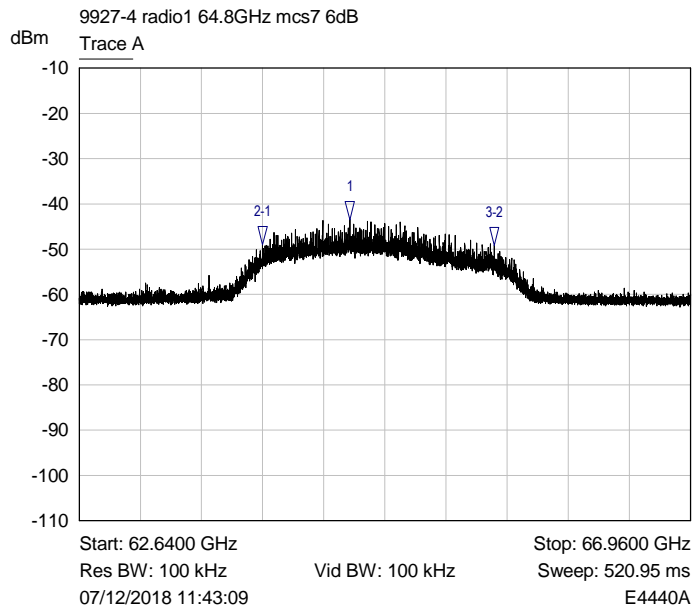

Mkr	Trace	X-Axis	Value	Notes
1 ▽	Trace A	64.5529 GHz	-43.43 dBm	
2-1 ▽	Trace A	-618.6497 MHz	-5.51 dB	
3-2 ▽	Trace A	1.6360 GHz	-0.18 dB	

Plot for 6 dB Bandwidth (MHz) Nominal Temp & Volts

RF Parameters: Band 57-66 GHz, Power 40 dBm, Channel Spacing 2.16 GHz, Modulation QPSK (MCS8), Channel 58.32 GHz

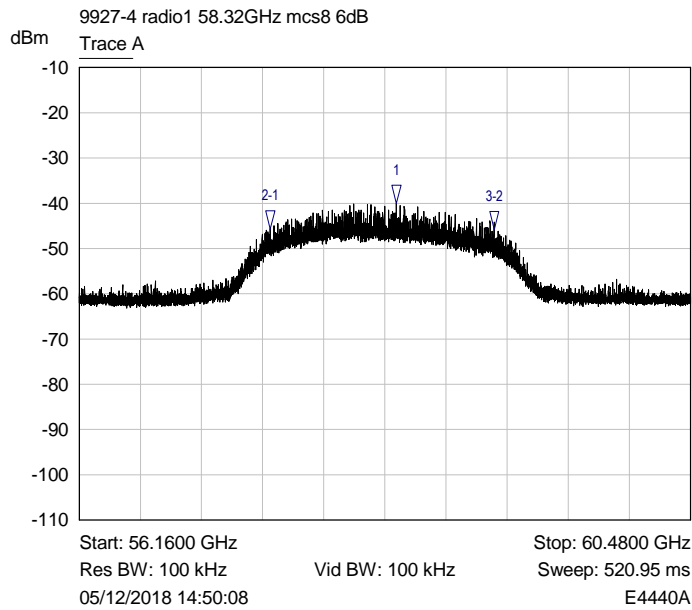

Mkr	Trace	X-Axis	Value	Notes
1 ▽	Trace A	58.4025 GHz	-40.00 dBm	
2-1 ▽	Trace A	-893.9568 MHz	-5.70 dB	
3-2 ▽	Trace A	1.5817 GHz	-0.21 dB	

Plot for 6 dB Bandwidth (MHz) Nominal Temp & Volts

RF Parameters: Band 57-66 GHz, Power 40 dBm, Channel Spacing 2.16 GHz, Modulation QPSK (MCS8), Channel 60.48 GHz

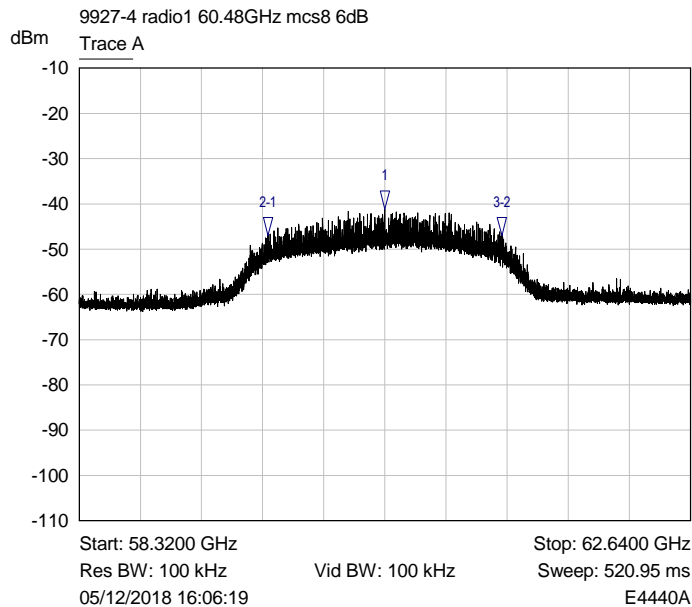

Mkr	Trace	X-Axis	Value	Notes
1 ▽	Trace A	60.4797 GHz	-41.16 dBm	
2-1 ▽	Trace A	-828.5582 MHz	-5.85 dB	
3-2 ▽	Trace A	1.6540 GHz	-0.07 dB	

Plot for 6 dB Bandwidth (MHz) Nominal Temp & Volts

RF Parameters: Band 57-66 GHz, Power 40 dBm, Channel Spacing 2.16 GHz, Modulation QPSK (MCS8), Channel 62.64 GHz

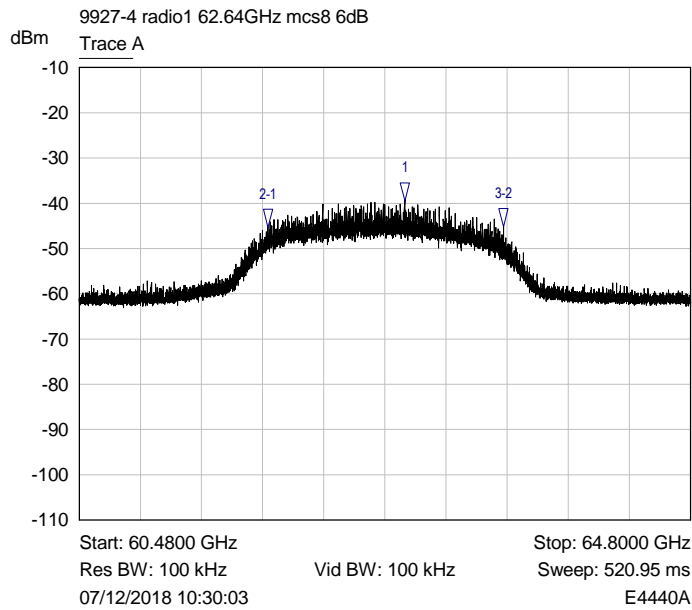

Mkr	Trace	X-Axis	Value	Notes
1 ▽	Trace A	62.7779 GHz	-39.46 dBm	
2-1 ▽	Trace A	-962.5198 MHz	-5.95 dB	
3-2 ▽	Trace A	1.6634 GHz	0.31 dB	

Plot for 6 dB Bandwidth (MHz) Nominal Temp & Volts

RF Parameters: Band 57-66 GHz, Power 40 dBm, Channel Spacing 2.16 GHz, Modulation QPSK (MCS8), Channel 64.8 GHz

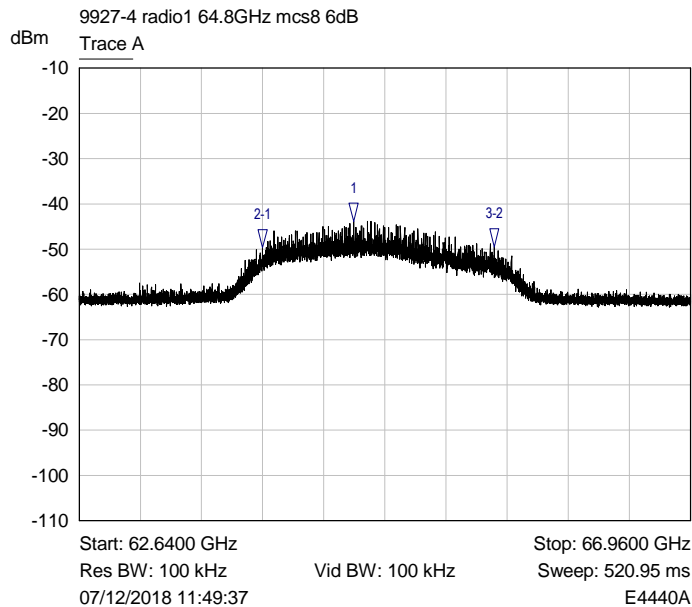

Mkr	Trace	X-Axis	Value	Notes
1 ▽	Trace A	64.5803 GHz	-43.84 dBm	
2-1 ▽	Trace A	-646.0750 MHz	-5.75 dB	
3-2 ▽	Trace A	1.6365 GHz	0.11 dB	

Plot for 6 dB Bandwidth (MHz) Nominal Temp & Volts

RF Parameters: Band 57-66 GHz, Power 40 dBm, Channel Spacing 2.16 GHz, Modulation QPSK (MCS9), Channel 58.32 GHz

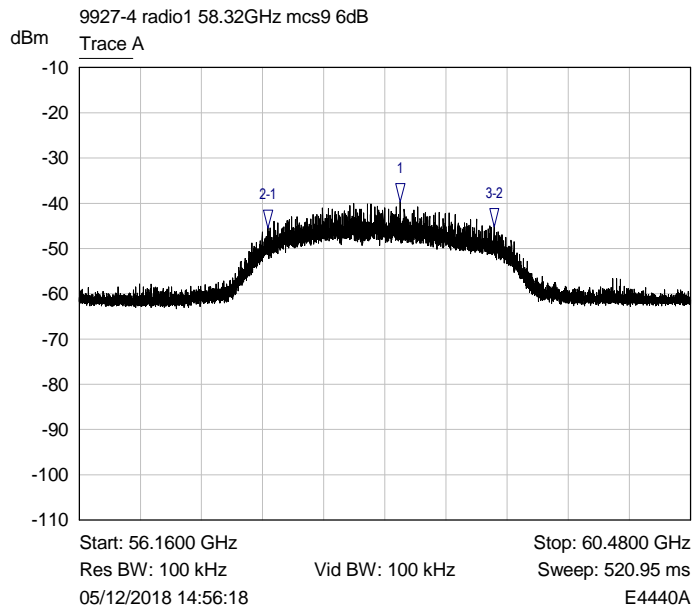

Mkr	Trace	X-Axis	Value	Notes
1	Trace A	58.4300 GHz	-39.72 dBm	
2-1	Trace A	-935.0946 MHz	-5.84 dB	
3-2	Trace A	1.5954 GHz	0.40 dB	

Plot for 6 dB Bandwidth (MHz) Nominal Temp & Volts

RF Parameters: Band 57-66 GHz, Power 40 dBm, Channel Spacing 2.16 GHz, Modulation QPSK (MCS9), Channel 60.48 GHz

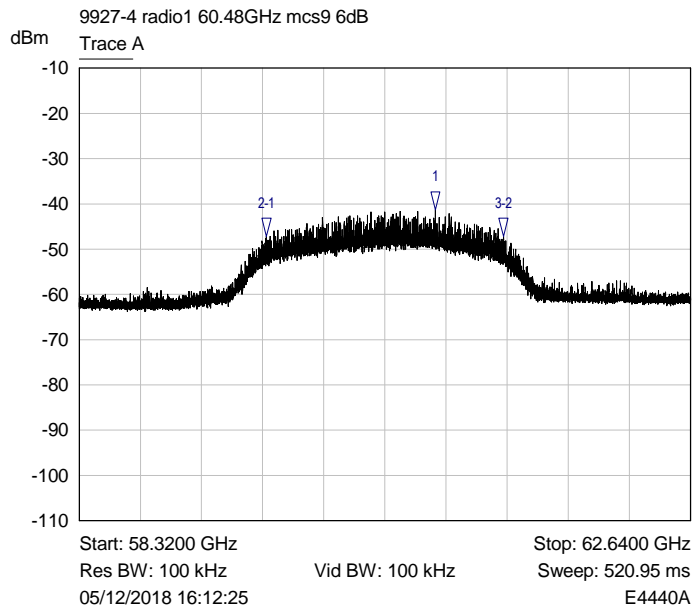

Mkr	Trace	X-Axis	Value	Notes
1	Trace A	60.8373 GHz	-41.30 dBm	
2-1	Trace A	-1.1962 GHz	-5.93 dB	
3-2	Trace A	1.6777 GHz	0.11 dB	

Plot for 6 dB Bandwidth (MHz) Nominal Temp & Volts

RF Parameters: Band 57-66 GHz, Power 40 dBm, Channel Spacing 2.16 GHz, Modulation QPSK (MCS9), Channel 62.64 GHz

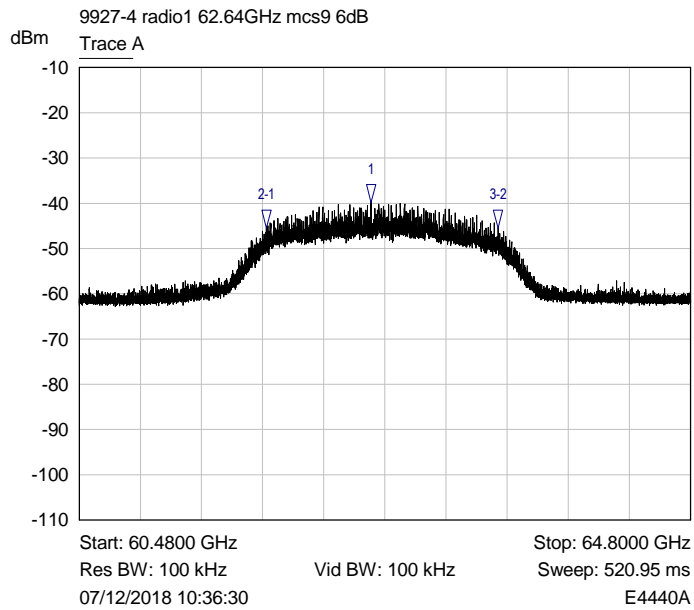

Mkr	Trace	X-Axis	Value	Notes
1	Trace A	62.5443 GHz	-39.85 dBm	
2-1	Trace A	-742.0632 MHz	-5.63 dB	
3-2	Trace A	1.6355 GHz	0.06 dB	

Plot for 6 dB Bandwidth (MHz) Nominal Temp & Volts

RF Parameters: Band 57-66 GHz, Power 40 dBm, Channel Spacing 2.16 GHz, Modulation QPSK (MCS9), Channel 64.8 GHz

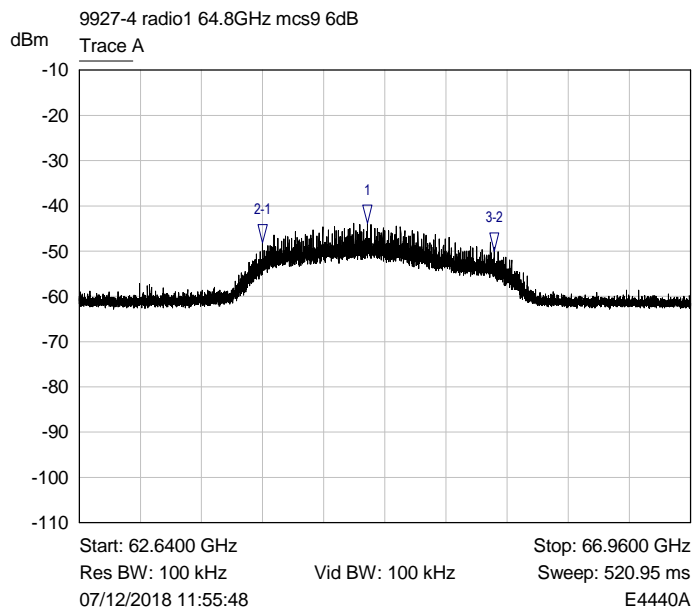

Mkr	Trace	X-Axis	Value	Notes
1	Trace A	64.6769 GHz	-43.91 dBm	
2-1	Trace A	-742.5906 MHz	-4.33 dB	
3-2	Trace A	1.6365 GHz	-1.70 dB	

Plot for 6 dB Bandwidth (MHz) Nominal Temp & Volts

RF Parameters: Band 57-66 GHz, Power 40 dBm, Channel Spacing 2.16 GHz, Modulation QPSK (MCS10), Channel 58.32 GHz

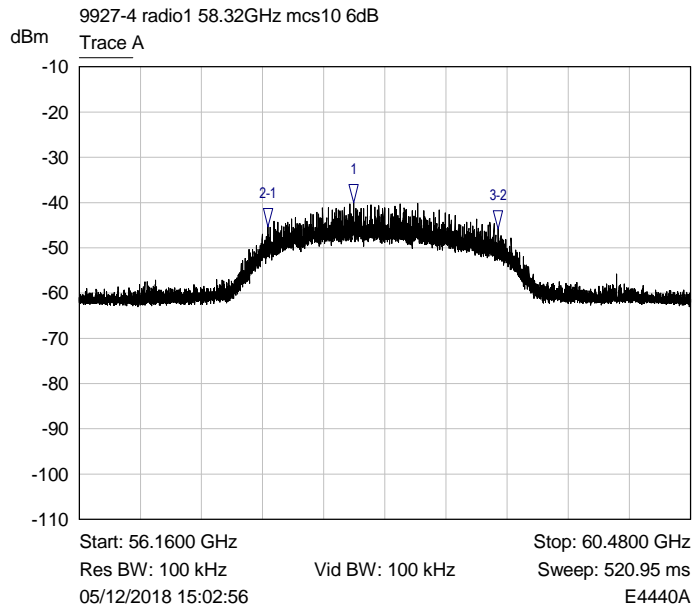

Mkr	Trace	X-Axis	Value	Notes
1 ▽	Trace A	58.0998 GHz	-39.92 dBm	
2-1 ▽	Trace A	-604.4097 MHz	-5.37 dB	
3-2 ▽	Trace A	1.6218 GHz	-0.51 dB	

Plot for 6 dB Bandwidth (MHz) Nominal Temp & Volts

RF Parameters: Band 57-66 GHz, Power 40 dBm, Channel Spacing 2.16 GHz, Modulation QPSK (MCS10), Channel 60.48 GHz

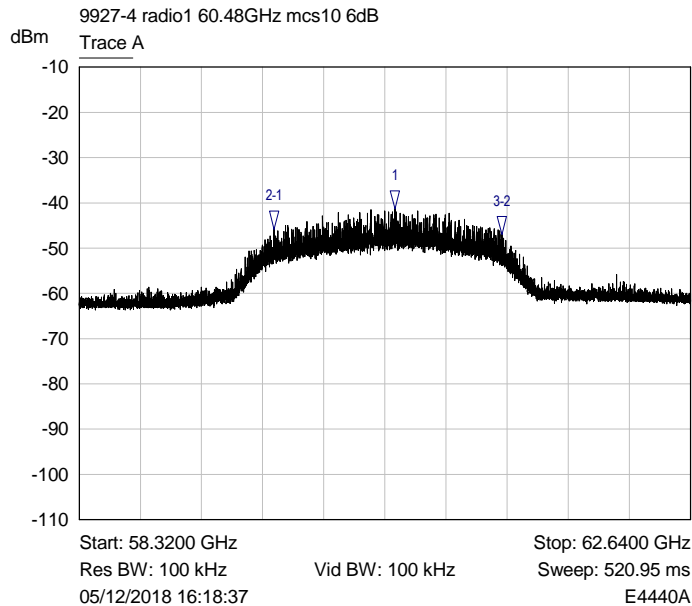

Mkr	Trace	X-Axis	Value	Notes
1 ▽	Trace A	60.5488 GHz	-41.27 dBm	
2-1 ▽	Trace A	-852.8189 MHz	-4.63 dB	
3-2 ▽	Trace A	1.6091 GHz	-1.03 dB	

Plot for 6 dB Bandwidth (MHz) Nominal Temp & Volts

RF Parameters: Band 57-66 GHz, Power 40 dBm, Channel Spacing 2.16 GHz, Modulation QPSK (MCS10), Channel 62.64 GHz

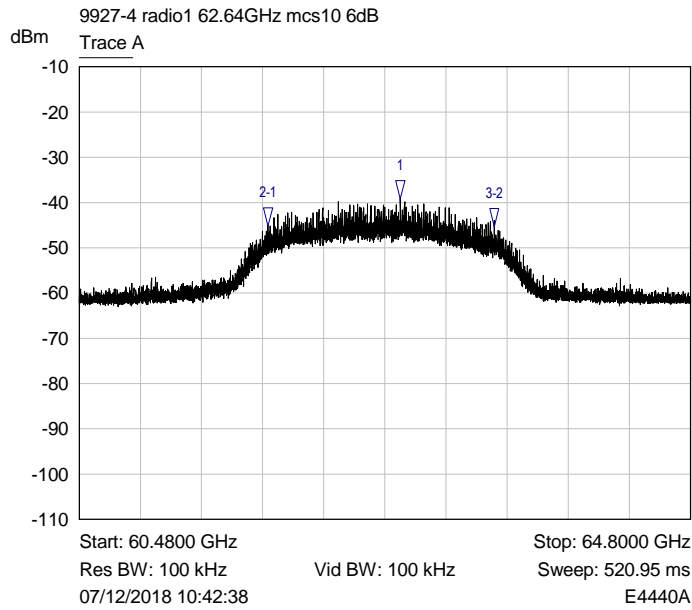

Mkr	Trace	X-Axis	Value	Notes
1 ▽	Trace A	62.7505 GHz	-39.24 dBm	
2-1 ▽	Trace A	-935.0946 MHz	-5.88 dB	
3-2 ▽	Trace A	1.5954 GHz	-0.25 dB	

Plot for 6 dB Bandwidth (MHz) Nominal Temp & Volts

RF Parameters: Band 57-66 GHz, Power 40 dBm, Channel Spacing 2.16 GHz, Modulation QPSK (MCS10), Channel 64.8 GHz

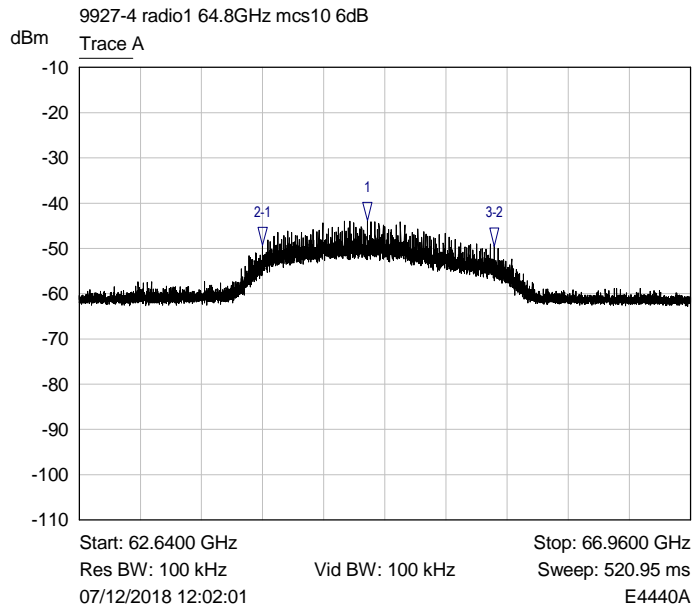

Mkr	Trace	X-Axis	Value	Notes
1 ▽	Trace A	64.6769 GHz	-43.75 dBm	
2-1 ▽	Trace A	-742.5906 MHz	-5.60 dB	
3-2 ▽	Trace A	1.6365 GHz	-0.07 dB	

Plot for 6 dB Bandwidth (MHz) Nominal Temp & Volts

RF Parameters: Band 57-66 GHz, Power 40 dBm, Channel Spacing 2.16 GHz, Modulation QPSK (MCS11), Channel 58.32 GHz

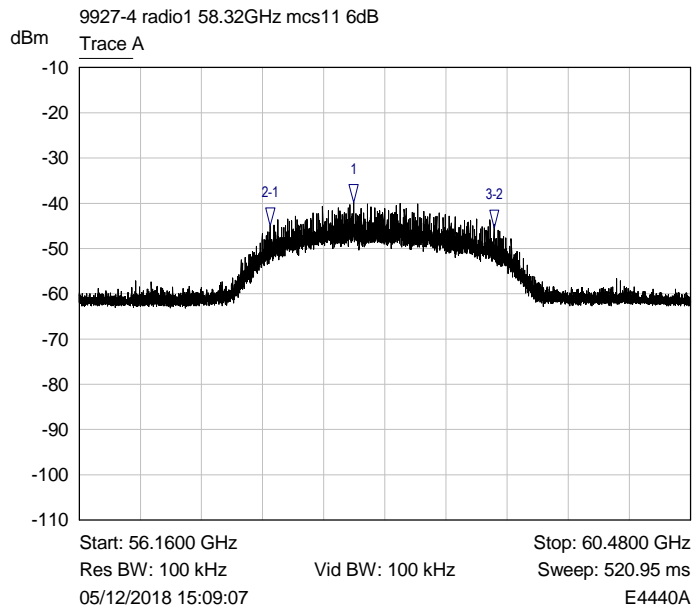

Mkr	Trace	X-Axis	Value	Notes
1 ▽	Trace A	58.0998 GHz	-39.81 dBm	
2-1 ▽	Trace A	-591.2245 MHz	-5.23 dB	
3-2 ▽	Trace A	1.5817 GHz	-0.52 dB	

Plot for 6 dB Bandwidth (MHz) Nominal Temp & Volts

RF Parameters: Band 57-66 GHz, Power 40 dBm, Channel Spacing 2.16 GHz, Modulation QPSK (MCS11), Channel 60.48 GHz

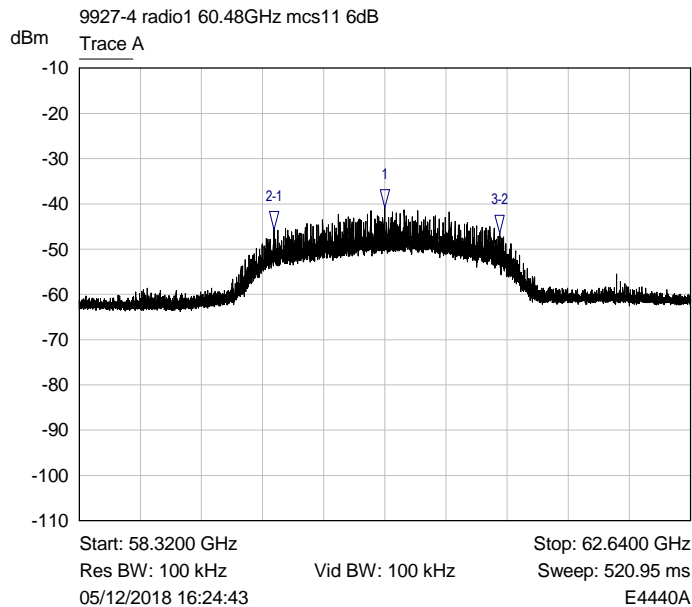

Mkr	Trace	X-Axis	Value	Notes
1 ▽	Trace A	60.4797 GHz	-40.90 dBm	
2-1 ▽	Trace A	-783.7285 MHz	-4.82 dB	
3-2 ▽	Trace A	1.5954 GHz	-0.78 dB	

Plot for 6 dB Bandwidth (MHz) Nominal Temp & Volts



RF Parameters: Band 57-66 GHz, Power 40 dBm, Channel Spacing 2.16 GHz, Modulation QPSK (MCS11), Channel 62.64 GHz

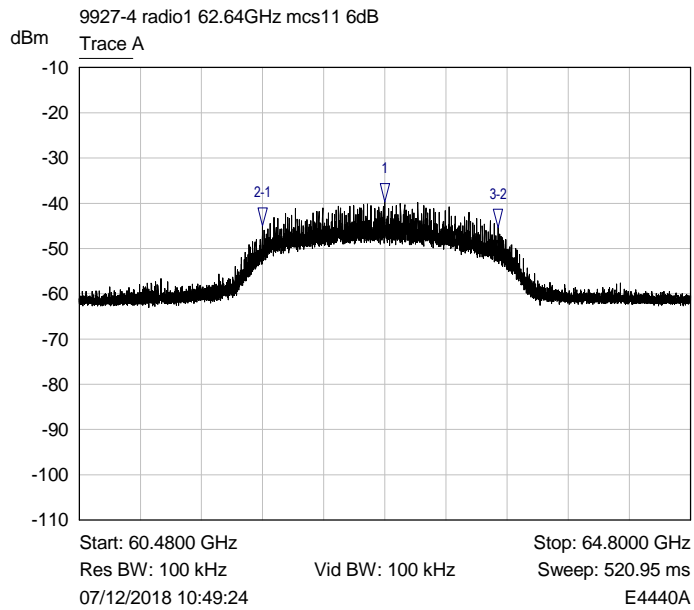

Mkr	Trace	X-Axis	Value	Notes
1	Trace A	62.6408 GHz	-39.64 dBm	
2-1	Trace A	-866.5316 MHz	-5.42 dB	
3-2	Trace A	1.6634 GHz	-0.36 dB	

Plot for 6 dB Bandwidth (MHz) Nominal Temp & Volts

RF Parameters: Band 57-66 GHz, Power 40 dBm, Channel Spacing 2.16 GHz, Modulation QPSK (MCS11), Channel 64.8 GHz

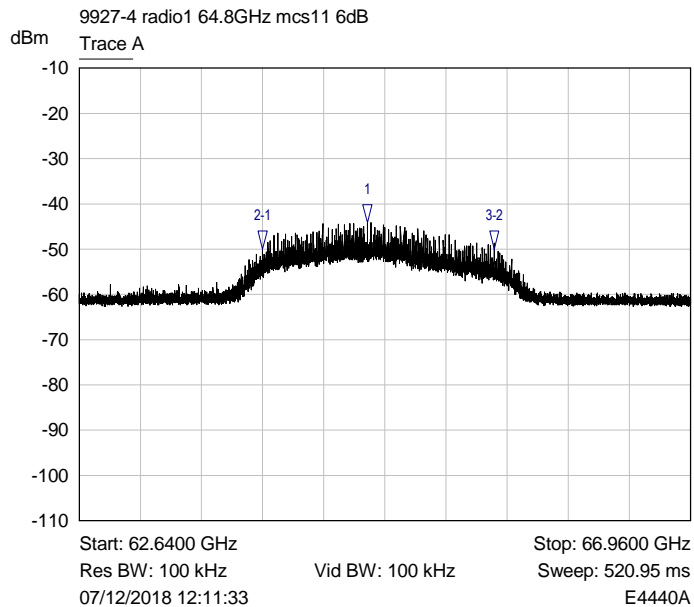

Mkr	Trace	X-Axis	Value	Notes
1	Trace A	64.6769 GHz	-44.14 dBm	
2-1	Trace A	-742.5906 MHz	-5.88 dB	
3-2	Trace A	1.6365 GHz	-0.01 dB	

Plot for 6 dB Bandwidth (MHz) Nominal Temp & Volts

RF Parameters: Band 57-66 GHz, Power 40 dBm, Channel Spacing 2.16 GHz, Modulation QPSK (MCS12), Channel 58.32 GHz

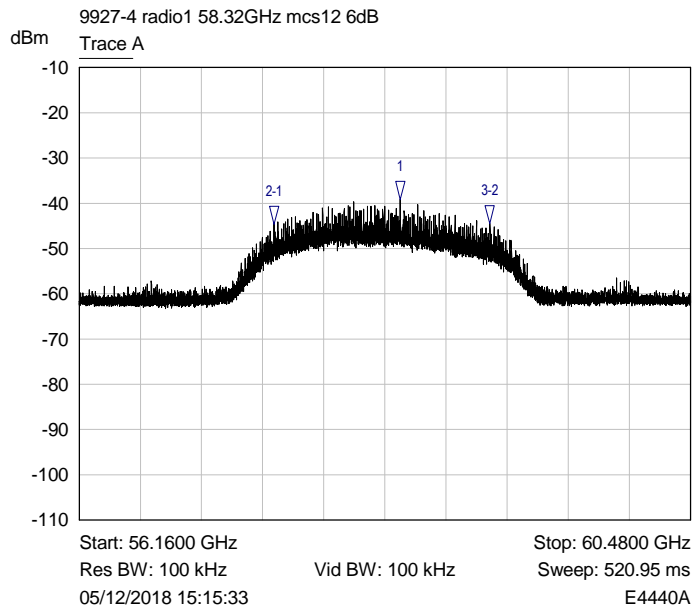

Mkr	Trace	X-Axis	Value	Notes
1 ▽	Trace A	58.4300 GHz	-39.10 dBm	
2-1 ▽	Trace A	-893.9568 MHz	-5.61 dB	
3-2 ▽	Trace A	1.5263 GHz	0.12 dB	

Plot for 6 dB Bandwidth (MHz) Nominal Temp & Volts

RF Parameters: Band 57-66 GHz, Power 40 dBm, Channel Spacing 2.16 GHz, Modulation QPSK (MCS12), Channel 60.48 GHz

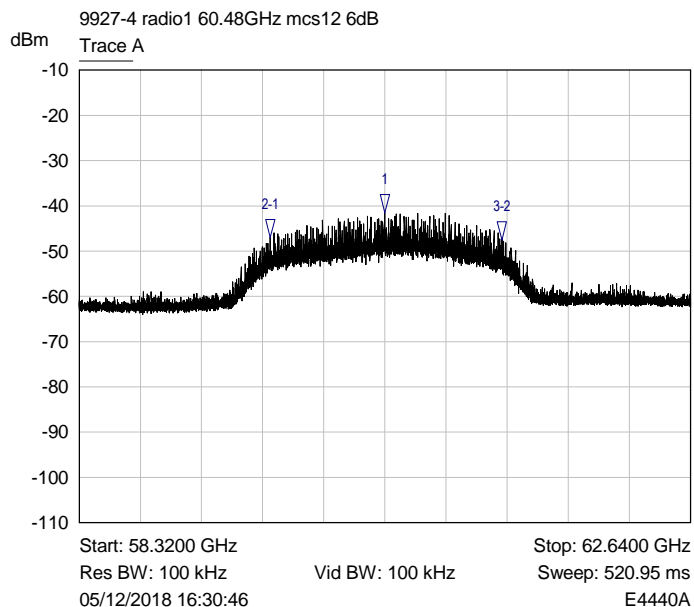

Mkr	Trace	X-Axis	Value	Notes
1 ▽	Trace A	60.4797 GHz	-41.51 dBm	
2-1 ▽	Trace A	-811.1537 MHz	-5.45 dB	
3-2 ▽	Trace A	1.6360 GHz	-0.49 dB	

Plot for 6 dB Bandwidth (MHz) Nominal Temp & Volts

RF Parameters: Band 57-66 GHz, Power 40 dBm, Channel Spacing 2.16 GHz, Modulation QPSK (MCS12), Channel 62.64 GHz

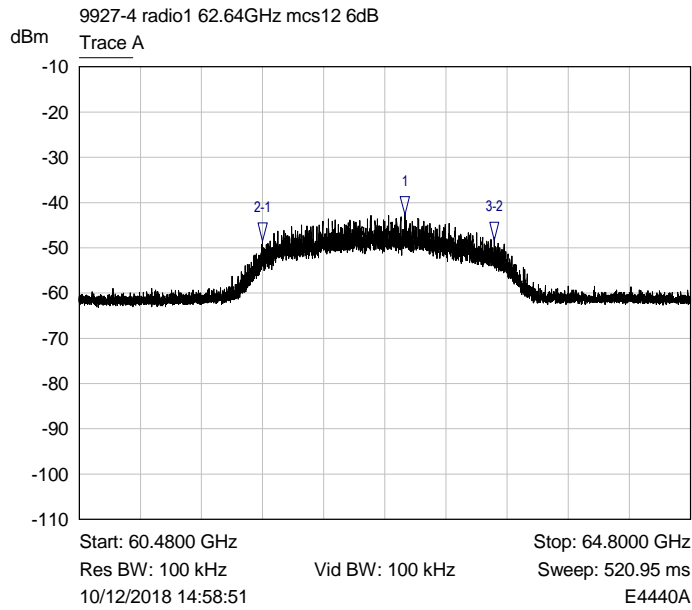

Mkr	Trace	X-Axis	Value	Notes
1 ▾	Trace A	62.7784 GHz	-42.65 dBm	
2-1 ▾	Trace A	-1.0037 GHz	-5.88 dB	
3-2 ▾	Trace A	1.6365 GHz	0.21 dB	

Plot for 6 dB Bandwidth (MHz) Nominal Temp & Volts

RF Parameters: Band 57-66 GHz, Power 40 dBm, Channel Spacing 2.16 GHz, Modulation QPSK (MCS12), Channel 64.8 GHz

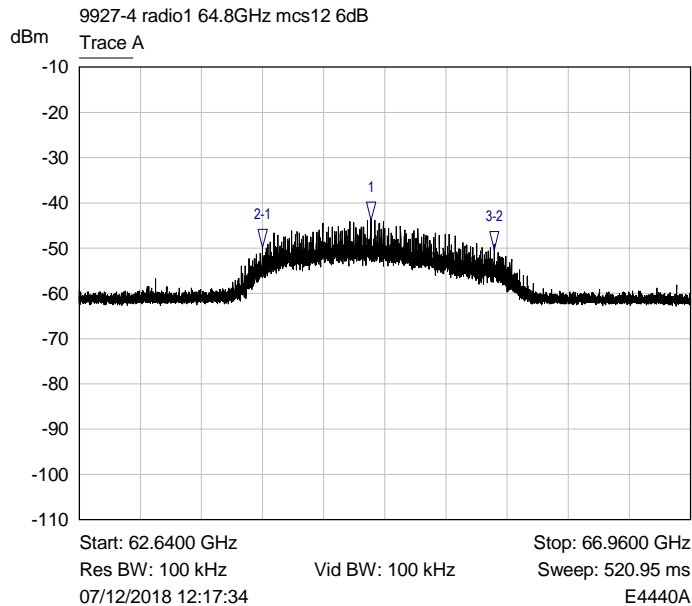

Mkr	Trace	X-Axis	Value	Notes
1 ▾	Trace A	64.7043 GHz	-43.84 dBm	
2-1 ▾	Trace A	-770.0159 MHz	-5.98 dB	
3-2 ▾	Trace A	1.6365 GHz	-0.42 dB	

Plot for 6 dB Bandwidth (MHz) Nominal Temp & Volts

## 7 Explanatory Notes

### 7.1 Explanation of Table of Signals Measured

Measurements are made as required by the standard. These measurements are made and recorded using detectors, either peak, quasi peak or average dependant on the test. A table of results has been given following the relevant plots. This table looks similar to the one illustrated below dependant on the measurements required by the test: -

Signal No.	Freq (MHz)	Peak Amp (dB $\mu$ V)	Pk – Lim 1 (dB)	QP Amp (dB $\mu$ V)	QP - Lim1 (dB)	Av Amp (dB $\mu$ V)	Av - Lim1 (dB)
1	12345	54.9	-10.5	48	-12.6	37.6	-14.4

Column One - Labelled Signal No. is an incremental number that the receiver has given to each signal that has been measured.

Column Two - Labelled Freq (MHz) is the approximate frequency of the signal received.

Column Three - Labelled Peak Amp (dB $\mu$ V) is the level of received signal that was measured in dB above 1 $\mu$ V using the peak detector.

Column Four - Labelled Pk - Lim1 (dB) is the difference in level from the peak signal given to the active limit line. If this column appears in the table the peak detector measurement is required by the standard for this test. The results entered in this column indicate the signal level relative to the compliance limit required. Negative numbers indicate that the product is compliant.

Column Five - Labelled QP Amp (dB $\mu$ V) is the level of received signal that was measured in dB above 1 $\mu$ V using the quasi-peak detector.

Column Six - Labelled QP - Lim1 (dB) is the difference in level from the quasi-peak signal given to the active limit line. If this column appears in the table the quasi-peak detector measurement is required by the standard for this test. The results entered in this column indicate the signal level relative to the compliance limit required. Negative numbers indicate that the product is compliant.

Column Seven - Labelled Av Amp (dB $\mu$ V) is the level of received signal that was measured in dB above 1 $\mu$ V using the average detector.

Column Eight - Labelled Av - Lim1 (dB) is the difference in level from the average signal given to the active limit line. If this column appears in the table the average detector measurement is required by the standard for this test. The results entered in this column indicate the signal level relative to the compliance limit required. Negative numbers indicate that the product is compliant.

Only signals highlighted in red are deemed to exceed the limit of the detector required.

### 7.2 Explanation of limit line calculations for radiated measurements

The limits given in the test standard are normally expressed as absolute values (e.g. in  $\mu$ V/m at a specified distance), whereas the measured values are expressed as peak, quasi peak or average values in dB $\mu$ V/m referenced to the measuring instrument inputs. RN Electronics calibrate the test set-up to account for any path losses, antenna gains, etc. so that the value read at the receiver relates directly to the absolute value required, except that it is expressed in dB relative to one microVolt and may need to take account of any alternative measuring distance used. Examples:

(a) limit of 500  $\mu$ V/m equates to  $20.\log(500) = 54$  dB  $\mu$ V/m.

(b) limit of 300  $\mu$ V/m at 10m equates to  $20.\log(300 \cdot 10/3) = 60$  dB  $\mu$ V/m at 3m

(c) limit of 30 µV/m at 30m, but below 30MHz, equates to  $20 \cdot \log(30) + 40 \cdot \log(30/3) = 69.5$  dBµV/m at 3m, as extrapolation factor below 30MHz is 40dB/decade per 15.31(f)(2).

The measurement receiver used for emissions testing, performs the field strength (FS) calculations automatically. The receiver combines the signal amplitude (RA), Antenna Factor (AF) and Cable Loss (CL) factors for the frequency to be measured.

Example calculation: - FS = RA + AF + CL.

Receiver amplitude (RA)	Antenna factor (3m) (AF)	Cable loss (CL)	Field strength result (3m) (FS)
20dBuV	25 dB	3 dB	48dBuV/m

Additional calculation examples per ANSI C63.10 clause 9.4 – 9.6 equations 21, 22, 25 & 26:

**Equation 21:**  $E_{\text{Linear}} = 10^{((E_{\text{Log}} - 120)/20)}$

And therefore equation 21 transposed is:  $E_{\text{Log}} = 20 \times \log(E_{\text{Linear}}) + 120$

Where:

$E_{\text{Linear}}$  is the field strength of the emission in V/m

$E_{\text{Log}}$  is the field strength of the emissions in dBµV/m

**Equation 22:**  $\text{EIRP} = E_{\text{Meas}} + 20 \log(d_{\text{Meas}}) - 104.7$

Where:

EIRP is equivalent isotropically radiated power in dBm

$E_{\text{Meas}}$  is the field strength of the emission at the measurement distance in dBµV/m

$d_{\text{Meas}}$  is the measurement distance in metres

**Equation 25:**  $\text{PD} = \text{EIRP}_{\text{Linear}} / 4\pi d^2$

And therefore equation 25 transposed is:  $\text{EIRP}_{\text{Linear}} = \text{PD} \times 4\pi d^2$

Where:

PD is the power density at distance specified by the limit, in W/m<sup>2</sup>

$\text{EIRP}_{\text{Linear}}$  is the equivalent isotropically radiated power in Watts

d is the distance at which the power density limit is specified in metres

**Equation 26:**  $\text{PD} = E_{\text{Spec limit}}^2 / 377$

And therefore equation 26 transposed is:  $E_{\text{Spec limit}} = \sqrt{(\text{PD} \times 377)}$

Where:

PD is the power density at distance specified by the limit, in W/m<sup>2</sup>

$E_{\text{Spec limit}}$  is the field strength at the distance specified by the limit in V/m

**Example:**

Radiated spurious emissions limit at 3metres of 90pW/cm<sup>2</sup>.

$90 \text{pW/cm}^2 \times 100^2 = 0.9 \text{ µW/m}^2 = (\text{EIRP Linear})$

Equation 25 transposed:  $0.9 \times 10^{-6} \times 4 \times \pi \times 3^2 = 0.0001017876 \text{ W}$

And

Equation 26 transposed:  $E_{\text{Spec limit}} = \sqrt{(0.9 \times 10^{-6} \times 377)} = 0.01842 \text{ V/m.}$

And

Equation 21 transposed:  $E_{\text{Log}} = 20 \log(0.01842) + 120 = 85.3 \text{ dBµV/m @ 3m.}$

## 8 Photographs

### 8.1 EUT Front View



### 8.2 EUT Reverse Angle

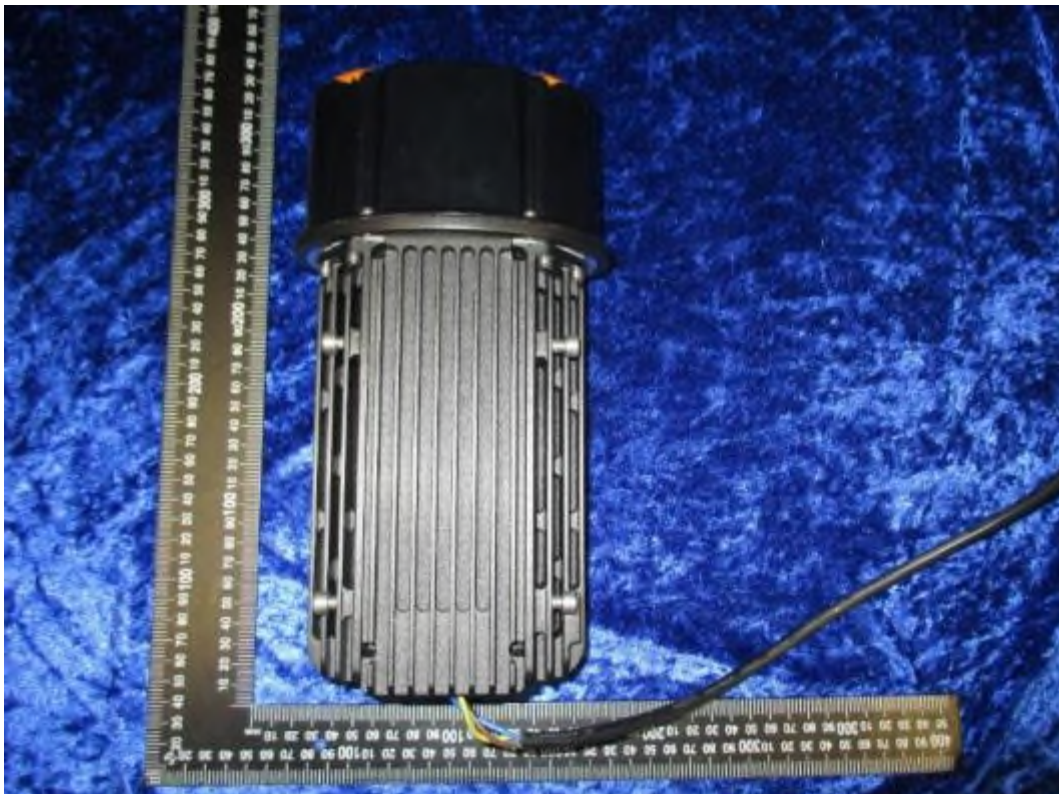

### 8.3 EUT Left side View



### 8.4 EUT Right side View



## 8.5 EUT Antenna

Note: Photos are blacked out due to confidentiality of internal photos

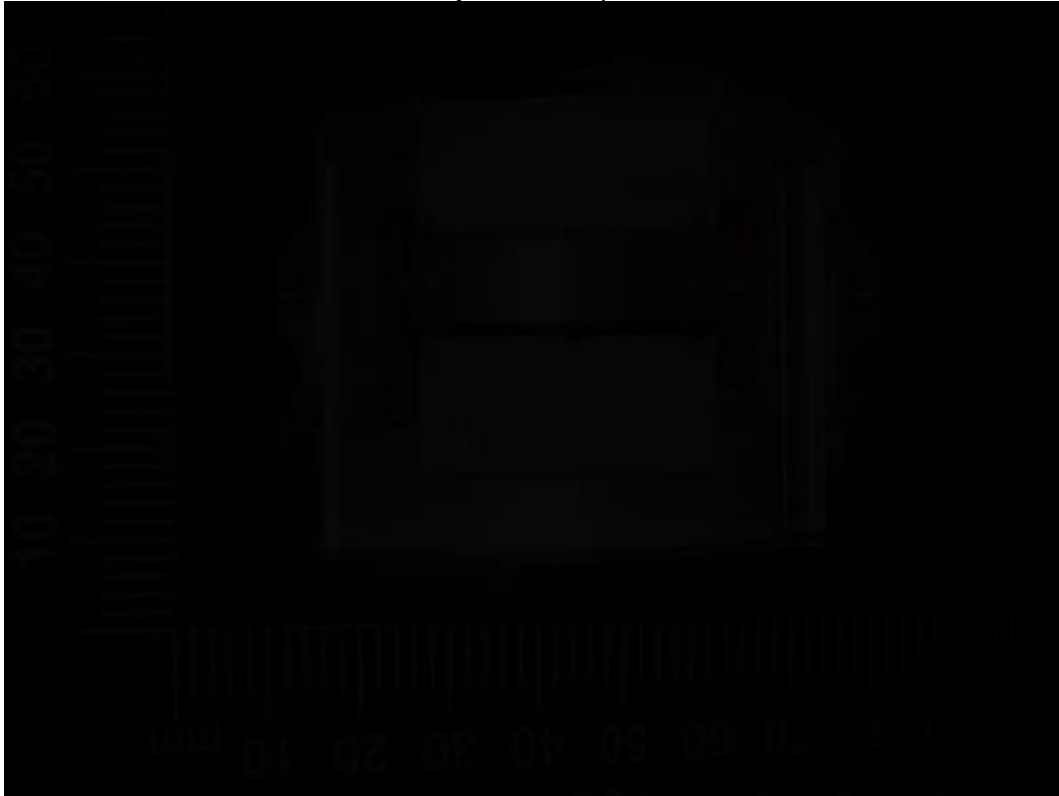





GPS antenna.

## 8.6 EUT Display & Controls



## 8.7 EUT Internal photos

Note: Photos are blacked out due to confidentiality of internal photos





No further disassembly was possible.

## 8.8 EUT ID Label





### 8.9 AC power line conducted emissions





### 8.10 Radiated emissions 30 MHz -1 GHz



### 8.11 Radiated emissions above 1 GHz

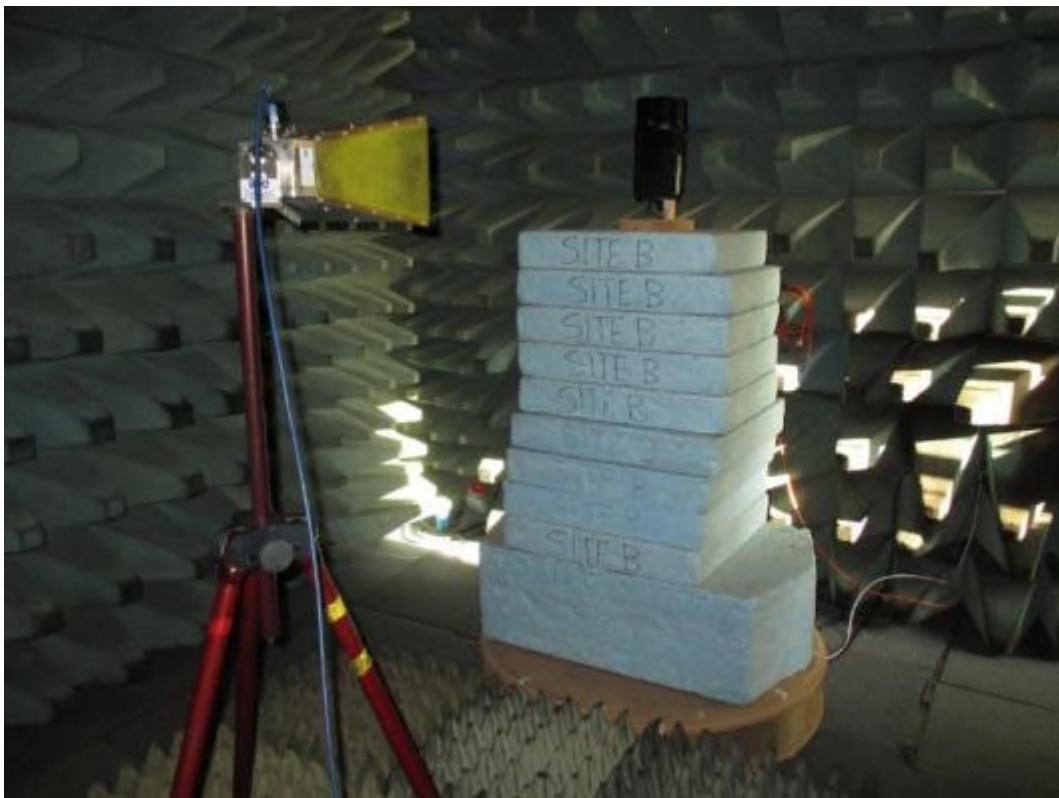
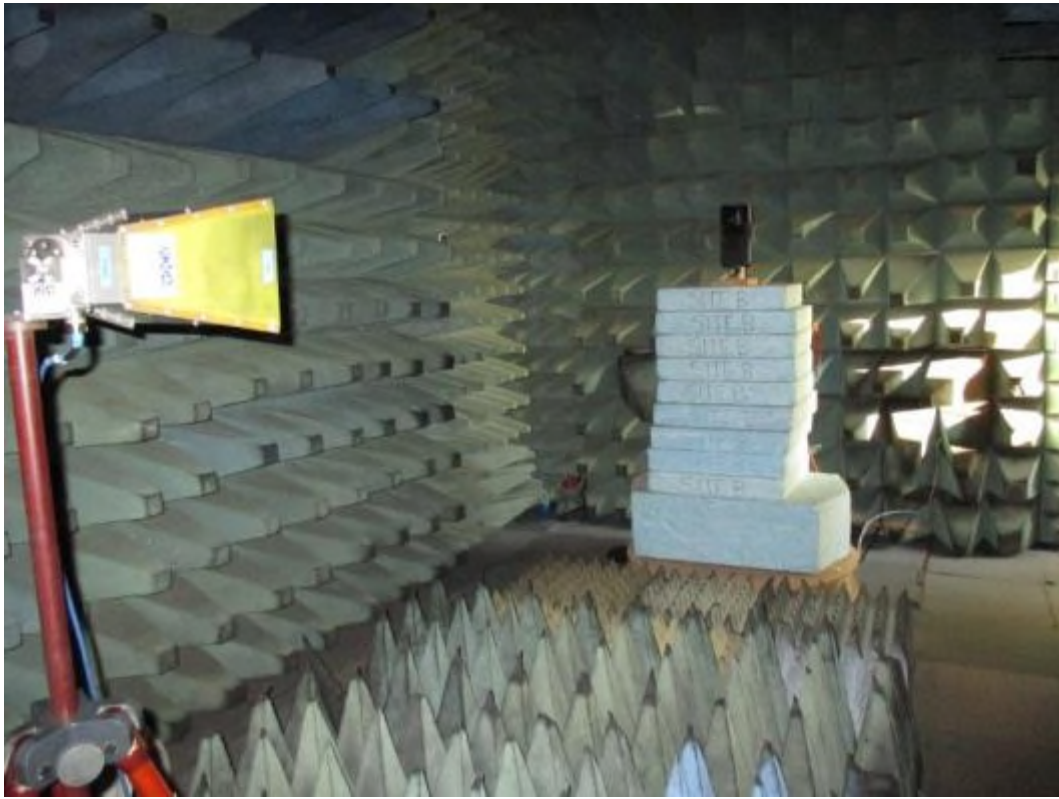

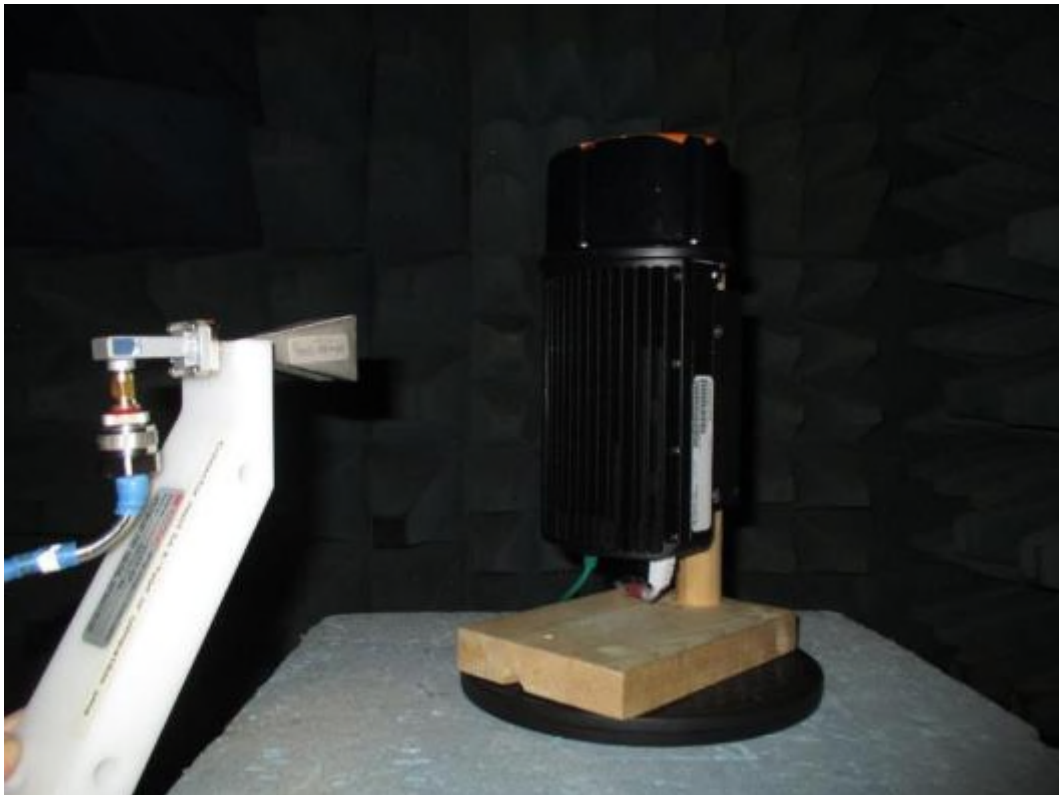



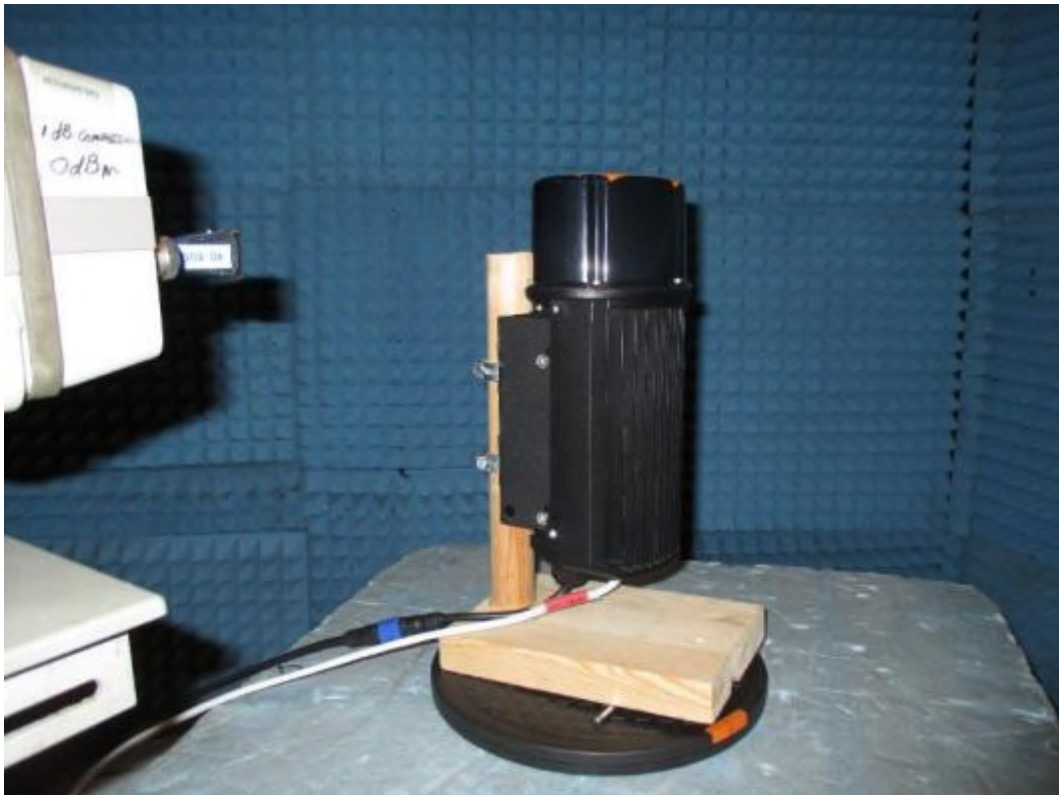

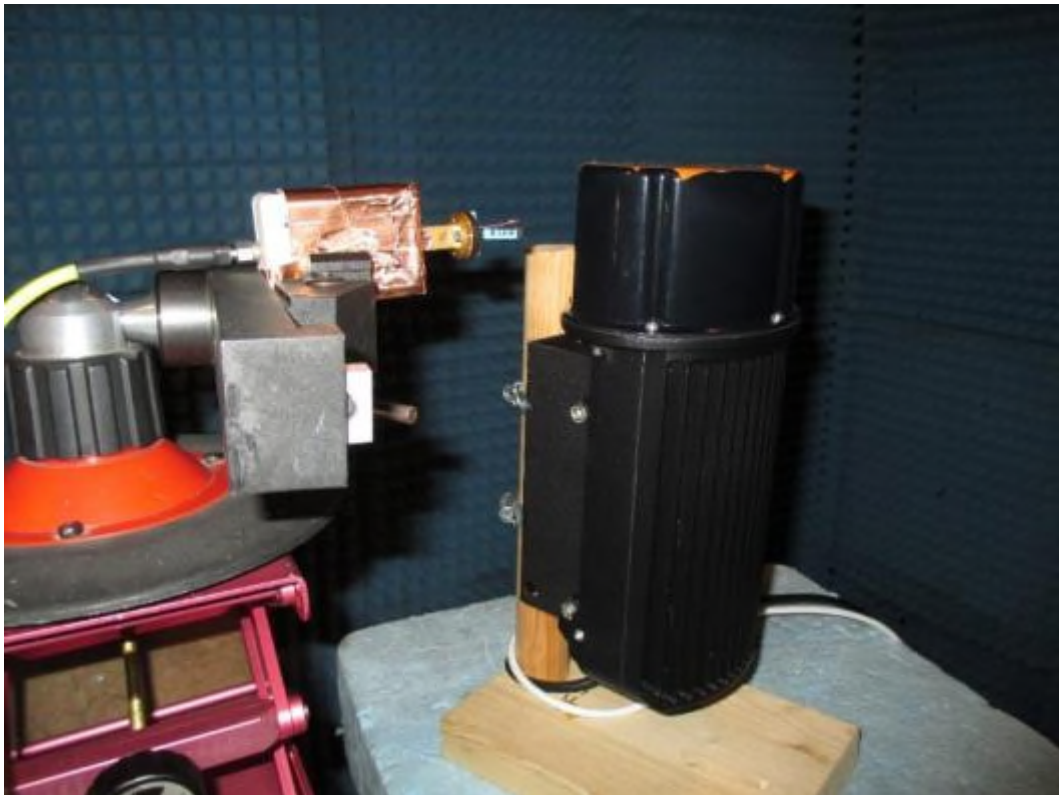



### 8.12 Radiated emission diagrams

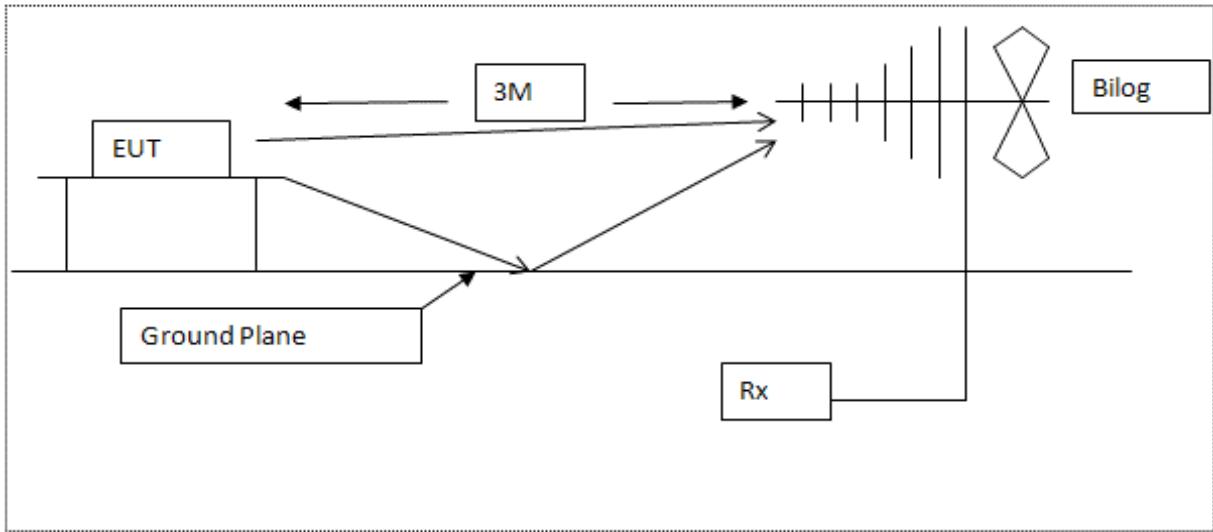

Diagram of the radiated emissions test setup 30 - 1000 MHz

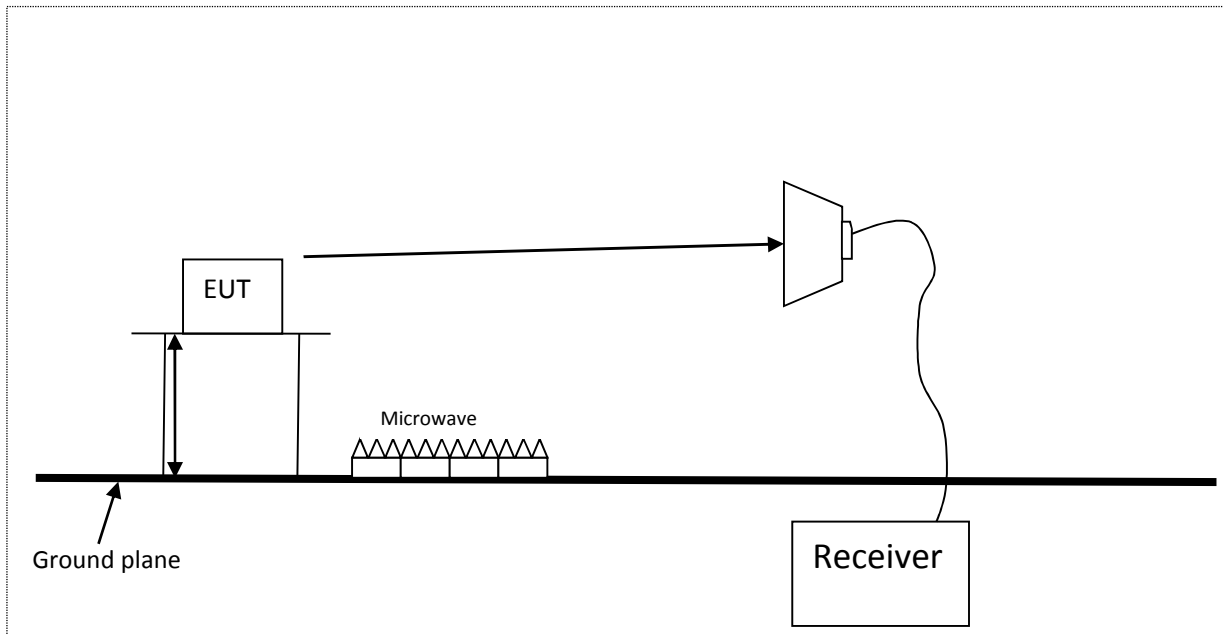

Diagram of the radiated emissions test setup above 1GHz

### 8.13 AC powerline conducted emission diagram

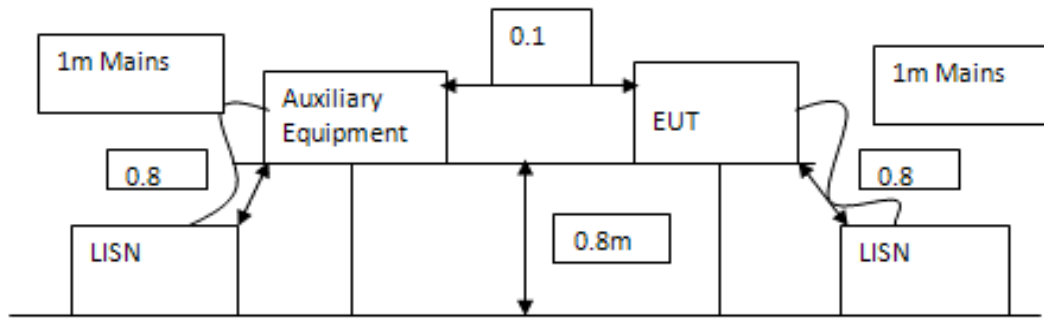

Diagram of the AC conducted emissions test setup

## 9 Test equipment calibration list

The following is a list of the test equipment used by R.N. Electronics Ltd to test the unit detailed within this report. In line with our procedures, the equipment was within calibration for the period during which testing was carried out.

RN No.	Model No.	Description	Manufacturer	Calibration date	Cal period
E035	11947A	Transient Limiter 9kHz - 200MHz	Hewlett Packard	17-Dec-2018	6 months
E150	MN2050	LISN 13A	Chase	19-Apr-2018	12 months
E289	8449B	22-40GHz opt H40 Block Down Converter	Hewlett Packard	14-Mar-2018	12 months
E296-6	11970W	Harmonic Mixer 75-110 GHz	Hewlett Packard	08-Dec-2017	36 months
E329	8349B	Microwave Amplifier 2-20 GHz	Hewlett Packard	19-Nov-2018	12 months
E330	2224-20	Antenna Flann Horn 26.5-40 GHz	FMI	23-Apr-2018	12 months
E411	N9039A	9 kHz - 1 GHz RF Filter Section	Agilent Technologies	10-Jul-2018	12 months
E412	E4440A	PSA 3 Hz - 26.5 GHz	Agilent Technologies	17-Jul-2018	24 months
E428	HF906	Horn Antenna 1-18 GHz	Rohde & Schwarz	24-Apr-2018	12 months
E465	PCR2000LA	AC Power Source 2kVA	Kikusui	18-Jul-2018	12 months
E485	11974-60028	Preselector PSU	Agilent Technologies	N/A	N/A
E486-2	11974A	Preselect Mixer 26.5 - 40GHz	Hewlett Packard	18-Sep-2018	12 months
E487	11974U	Preselect Mixer 40 - 60GHz	Agilent Technologies	12-Sep-2018	24 months
E503	2524-20	Horn Antenna 50-75 GHz	FMI	23-Apr-2018	12 months
E555	CMV 5E-1	Variac 5A	Carroll & Meynell Ltd	N/A	N/A
E562	83555A	Source 33-50GHz	Agilent Technologies	#20-Feb-2019	12 months
E577	2511	Attenuator Rotary 50-76GHz	Flann Microwave	#21-Feb-2019	12 months
E579	27240	Horn Std Gain 75GHz - 110GHz	FMI Ltd	23-Apr-2018	12 months
E599	ML4803A	Power meter	Anritsu	03-Sep-2018	12 months
E600	MA4002B, MP716A4	Sensor Adaptor with 50 GHz - 75 GHz Waveguide Sensor	Anritsu	03-Sep-2018	12 months
E602	MG3692A	Signal Generator 10MHz - 20GHz	Anritsu	#04-Feb-2019	24 months
E624	E4440A	PSA 3 Hz - 26.5 GHz	Agilent Technologies	09-Jan-2018	24 months
E627	DSO5052A	Oscilloscope 2CH 500MHz	Agilent Technologies	15-May-2018	12 months
E638	11974VE01	Preselected Mixer 50 - 80GHz	Agilent Technologies	#21-Feb-2019	24 months
E712	WM780F	Mixer 90-140GHz	Tektronix	03-May-2018	24 months
E714	PM 140_3_1	Frequency Tripler 110-170GHz	Teratech Components Ltd	07-Jul-2016	36 months
E716	-	Horn Std Gain 40-60GHz	-	23-Apr-2018	12 months
E719	-	Horn Std Gain 90-140GHz	-	28-Jun-2018	12 months
E720	28240	Horn Std Gain 90-140GHz	Flann	28-Jun-2018	12 months
E722	861G/387	Horn Std Gain 140-220GHz	Alpha Industries Inc	01-Aug-2018	12 months
E743	RR2017 4/2dB	Attenuator 4/2dB 30-1000MHz	RN Electronics	#11-Feb-2019	12 months
E755	N9030B	PXA 3Hz to 50GHz	Keysight	04-Jun-2018	12 months
E760	M05HWDX	Mixer 140-220GHz	OML Inc	03-May-2018	12 months
E771	861G/387	Horn Std Gain 140-220GHz WR5	Alpha	24-Apr-2018	12 months
E781	MX4-15-F	Multiplier 50 - 75GHz X4 WR15	MMWave Group	10-Sep-2018	12 months
E807	10MHz OCXO	Frequency Standard 10MHz OCXO	BG7TBL	06-Dec-2018	12 months
E829	47324H-1211	Detector Broadband 50-75GHz	Hughes	10-Sep-2018	12 months
E852	LPF10	Filter - 10MHz Low Pass	G4HUP	#19-Mar-2019	12 months
LPE364	CBL6112A	Antenna Bilog 30MHz - 2GHz	Chase Electronics Ltd	21-Mar-2018	24 months
NSA-M	NSA - M	NSA - Site M	RN Electronics	#09-Jan-2019	36 months
S036	FMH1 420	Temperature & Humidity Test Chamber	JTS Ltd	N/A	N/A
TMS57	2534	Digital Multimeter	Philips	08-Mar-2017	24 months
TMS78	3160-08	Horn Std Gain 12.4-18 GHz	ETS Systems	26-Jul-2018	12 months
TMS79	3160-09	Horn Std Gain 18-26.5 GHz	ETS Systems	26-Jul-2018	12 months
TMS80	206-3722	Digital Thermometer & K Probe	RS Components Ltd	21-Nov-2018	12 months
ZSW1	V2.2	Measurement Software Suite	RN Electronics	N/A	N/A

# Equipment was within calibration dates for tests and has been re-calibrated since/during date of tests.

File Name: Cambridge Communication Systems Ltd.9927-4 Issue 03

**QMF21J - Issue 05 - RNE Issue 03; 47 CFR Part 15C 2018**

## 10 Auxiliary and peripheral equipment

### 10.1 Customer supplied equipment

Item No.	Model No.	Description	Manufacturer	Serial No.
1	Aspire E15	Laptop and PSU	Acer	-
2	GS108E	Network switch	Netgear	3UH1465C00763

### 10.2 RN Electronics supplied equipment

RN No.	Model No.	Description	Manufacturer	Serial No
P272	18V10	PSU 18V 10A	Kingshill	335

## 11 Condition of the equipment tested

In order for the EUT to produce the results shown within this report the following modifications, if any, were implemented.

### 11.1 Modifications before test

No modifications were made before test by RN Electronics Ltd.

### 11.2 Modifications during test

For radiated emissions above 1 GHz the firmware was modified by the applicant to reduce the Voltage Controlled Oscillator bias voltage. The firmware version changed from V 0.3 to V 3. This version was also used for AC power line conducted emissions and Radiated emissions 30 MHz -1 GHz. Checks were made on EIRP and bandwidth results to ensure that they weren't affected by the firmware modification.



## 12 Description of test sites

Site A	Radio Laboratory and Anechoic Chamber
Site B	Semi-Anechoic Chamber and Control Room FCC Registration No. 293246 IC Registration No. 5612A-4
Site C	Transient Laboratory
Site D	Screened Room (Conducted Immunity)
Site E	Screened Room (Control Room for Site D)
Site F	Screened Room (Conducted Emissions)
Site G	Screened Room (Control Room for Site H)
Site H	3m Semi-Anechoic Chamber (indoor OATS) FCC Registration No. 293246 IC Registration No. 5612A-2
Site J	Transient Laboratory
Site K	Screened Room (Control Room for Site M)
Site M	3m Semi-Anechoic Chamber (indoor OATS) FCC Registration No. 293246 IC Registration No. 5612A-3
Site N	Radio Laboratory
Site Q	Fully-Anechoic Chamber
Site OATS	3m and 10m Open Area Test Site FCC Registration No. 293246 IC Registration No. 5612A-1
Site R	Screened Room (Conducted Immunity)
Site S	Safety Laboratory
Site T	Transient Laboratory

## 13 Abbreviations and units

%	Percent	LBT	Listen Before Talk
µA/m	microAmps per metre	LO	Local Oscillator
µV	microVolts	mA	milliAmps
µW	microWatts	max	maximum
AC	Alternating Current	kPa	Kilopascal
ALSE	Absorber Lined Screened Enclosure	Mbit/s	MegaBits per second
AM	Amplitude Modulation	MHz	MegaHertz
Amb	Ambient	mic	Microphone
ATPC	Automatic Transmit Power Control	min	minimum
BER	Bit Error Rate	mm	milliMetres
°C	Degrees Celsius	ms	milliSeconds
C/I	Carrier / Interferer	mW	milliWatts
CEPT	European Conference of Postal and Telecommunications Administrations	NA	Not Applicable
COFDM	Coherent OFDM	nom	Nominal
CS	Channel Spacing	nW	nanoWatt
CW	Continuous Wave	OATS	Open Area Test Site
dB	deciBels	OFDM	Orthogonal Frequency Division Multiplexing
dBµA/m	deciBels relative to 1µA/m	ppm	Parts per million
dBµV	deciBels relative to 1µV	PRBS	Pseudo Random Bit Sequence
dBc	deciBels relative to Carrier	QAM	Quadrature Amplitude Modulation
dBm	deciBels relative to 1mW	QPSK	Quadrature Phase Shift Keying
DC	Direct Current	R&TTE	Radio and Telecommunication Terminal Equipment
DTA	Digital Transmission Analyser	Ref	Reference
EIRP	Equivalent Isotropic Radiated Power	RF	Radio Frequency
ERP	Effective Radiated Power	RFC	Remote Frequency Control
EU	European Union	RSL	Received Signal Level
EUT	Equipment Under Test	RTP	Room Temperature and Pressure
FM	Frequency Modulation	RTPC	Remote Transmit Power Control
FSK	Frequency Shift Keying	Rx	Receiver
g	Grams	s	Seconds
GHz	GigaHertz	SINAD	Signal to Noise And Distortion
Hz	Hertz	Tx	Transmitter
IF	Intermediate Frequency	V	Volts
kHz	kiloHertz		