



Standard Burner Systems:

- G45-**(P)A
- G45**-01(M)(P)
- G45**-11(M)(P)
- G45**-15(M)(P)
- G45**-17(M)(P)

****Sizes:**
(16/19, 18/20, 24, 30, 36)

For indoor stainless steel models;
add (-SS) to end of model #



DESIGN CERTIFIED
to
Vented Decorative Appliance
ANSI Z21.60-2012
CSA 2.26-2012

**FOR INSTALLATION IN
SOLID-FUEL BURNING
FIREPLACES***

G45 SERIES VENTED GAS LOG SETS (REGULATED)

WARNING

If the information in this manual is not followed exactly, a fire or explosion may result, causing property damage, personal injury, or loss of life.

Do not store or use gasoline or other flammable vapors and liquids in the vicinity of this or any other appliance.

WHAT TO DO IF YOU SMELL GAS:

- Open a window.
- Do not try to light any appliance.
- Do not touch any electrical switch; do not use any phone in the building.
- Immediately call the gas supplier from a neighbor's phone. Follow gas supplier's instructions.
- If you cannot reach the gas supplier, call the fire department.

Installation and service must be performed by a qualified professional installer, service agency, or the gas supplier.

This appliance is only for use with the type of gas indicated on the rating plate.

IMPORTANT: READ THESE INSTRUCTIONS CAREFULLY BEFORE STARTING INSTALLATION OF THE LOG SET

The Real-Fyre gas log set is to be installed only in a solid-fuel burning fireplace with a working flue and constructed of noncombustible material. The installation, including provisions for combustion and ventilation air must conform with the *National Fuel Gas Code, ANSI Z223.1/NFPA 54*, or the *CSA B149.1, Natural Gas and Propane Installation Code*, and applicable local building codes.

A damper clamp is included to maintain the minimum permanent vent opening and to prevent full closure of the damper blade. **The chimney damper MUST be fully opened when burning the log set. The log set is designed to burn with yellow flames; thus adequate ventilation is absolutely necessary.**

To comply with certification, listings, and building code acceptances, and for safe operation and proper performance of this log set, use ONLY Peterson parts and accessories. Use of other controls, parts, and accessories that are not designed for use with Real-Fyre gas log sets is prohibited and will void all warranties, certifications, listings, and building code approvals, and may cause property damage, personal injury, or loss of life.

***Note:** Solid-fuels shall not be burned in a fireplace where a decorative appliance is installed.



INSTALLER:
Leave this manual with the appliance.
CONSUMER:
Retain this manual for future reference.



Systèmes standard de brûleur:

G45-**(P)A
G45-**-01(M)(P)
G45-**-11(M)(P)
G45-**-15(M)(P)
G45-**-17(M)(P)

****Sizes:**

(16/19, 18/20, 24, 30, 36)

Pour les modèles d'intérieur
d'acier inoxydable ; ajoutez (-SS)
à l'extrémité du modèle #



CONCEPTION CERTIFIÉE

à

Vented Decorative Appliance

ANSI Z21.60-2012

CSA 2.26-2012

**POUR L'INSTALLATION EN
CHEMINÉES BRÛLANTES DE
COMBUSTIBLE SOLIDE***

LA SÉRIE G45 A EXHALÉ LA NOTATION DE GAZ RÉGLÉE (RÉGLÉ)

AVERTISSEMENT

Si l'information en ce manuel n'est pas suivie exactement, une incendie ou une explosion peut résulter, entraînant des dégâts matériels, des blessures, ou la perte de la vie.

Ne stockez pas ou n'employez pas l'essence ou d'autres vapeurs et liquides inflammables à proximité de ceci ou d'aucun autre appareil.

CE QUI À FAIRE SI VOUS SENTEZ LE GAZ:

- Ouvrez une fenêtre.
- N'essayez pas de n'allumer aucun appareil.
- Ne touchez aucun commutateur électrique; n'utilisez aucun téléphone dans le bâtiment.
- Appelez immédiatement le fournisseur de gaz du téléphone du voisin. Suivez les instructions du fournisseur de gaz.
- Si vous ne pouvez pas atteindre le fournisseur de gaz, appelez le département de feu.

L'installation et le service doivent être assurés par un installateur qualifié et professionnel, l'agence de service, ou le fournisseur de gaz.

Cet appareil sert seulement avec le type de gaz indiqué de la plaque de contrôle.

INSTALLATEUR :

Laissez ce manuel avec l'appareil.

CONSOMMATEUR:

Maintenez ce manuel pour la future référence.



**IMPORTANT: LISEZ CES INSTRUCTIONS
SOIGNEUSEMENT AVANT DE
COMMENCER L'INSTALLATION DE
L'ENSEMBLE DE NOTATION.**

L'ensemble de notation de gaz d'Real-Fyre doit être installée seulement dans une cheminée brûlante de combustible solide avec une conduite de cheminée fonctionnante et être construit avec du matériel non-combustible. L'installation, y compris des dispositions pour l'air de combustion et de ventilation doit se conformer au code national de gaz de carburant, la norme ANSI Z223.1/NFPA 54, ou le CSA B149.1, code d'installation de gaz naturel et de propane, et codes du bâtiment locaux applicables.

Une bride plus humide est incluse pour maintenir l'ouverture permanente minimum de passage et pour empêcher la pleine fermeture de la lame plus humide. L'amortisseur de cheminée DOIT être entièrement ouvert en brûlant la notation réglée. L'ensemble de notation est conçu pour brûler avec les flammes jaunes; ainsi à ventilation proportionnée est absolument nécessaire.

Pour se conformer à la certification, les listes, et les acceptations de codes du bâtiment, et pour l'exploitation sûre et l'exécution appropriée de cet ensemble de notation, utilisent SEULEMENT des pièces et des accessoires d'Peterson. L'utilisation d'autres commandes, pièces, et accessoires qui ne sont pas conçus pour l'usage avec des ensembles de notation de gaz d'Real-Fyre est interdite et videra toutes les garanties, certifications, listes, et approbations de codes du bâtiment, et peut causer des dégâts matériels, le dommage corporel, ou des pertes humaines.

***Note:** des Plein-carburants ne seront pas brûlés dans une cheminée où un appareil décoratif est installé.

TABLE OF CONTENTS

4	REPLACEMENT BURNER PARTS LIST
5	SAFETY CONTROL SYSTEM FOR MANUAL SERIES
5	SAFETY CONTROL SYSTEM FOR 17 SERIES
6	SAFETY CONTROL SYSTEM FOR 15 SERIES
6	SAFETY CONTROL SYSTEM FOR 01 SERIES
7	SAFETY CONTROL SYSTEM FOR 11 SERIES
9	IMPORTANT PRE-INSTALLATION AND FIREPLACE SAFETY INFORMATION
10	IMPORTANT INFORMATION
10	FIREPLACE SIZE REQUIREMENTS
11	INSTALLATION
11	INSTALLING THE BURNER
12	GRANULE, EMBER, AND GRATE PLACEMENT
13	01 VALVE MODELS ONLY
13	CONNECTING THE IGNITION PACK TO THE VALVE
13	INSTALLING OR REPLACING BATTERIES FOR IGNITION MODULE PACK
13	SWITCH BOX PLACEMENT
14	LOG PLACEMENT
15	CHARRED LOG PLACEMENT
15	SCREEN AND EMBERS PLACEMENT
17	LIGHTING INSTRUCTIONS - MANUAL PILOT AND SERIES 17 VALVE
19	LIGHTING INSTRUCTIONS - SERIES 15 VALVE
21	LIGHTING INSTRUCTIONS - SERIES 01 VALVE
23	LIGHTING INSTRUCTIONS - SERIES 11 VALVE
24	NOTES PAGE
25	PILOT BURNER ADJUSTMENT
26	TROUBLESHOOTING
27	FLAME DESCRIPTION
28	WARRANTY

REPLACEMENT BURNER PARTS LIST

Item	Description	16/19" model		18/20" model		24" model		30" model		36" model	
		Part No.	Qty.	Part No.	Qty.	Part No.	Qty.	Part No.	Qty.	Part No.	Qty.
1.	Grate	SD-16	1	SD-18	1	SD-24	1	SD-30	1	SX-36	1
2.	Log locators with screws and nuts	UP-8	2	UP-8	2	UP-8	2	UP-8	2	UP-8	2
3.	Standard burner pan or Stainless steel burner pan	GG4516(P*)	1	GG4518(P*)	1	GG4524(P*)	1	GG4530(P*)	1	GG4530(P*)	1
		GG45-16SS(P*)	1	GG45-18SS(P*)	1	GG45-24SS(P*)	1	GG45-30SS(P*)	1	GG45-30SS(P*)	1
4.	Flame diverter bracket	SH-1	1	SH-1	1	SH-1	1	SH-1	1	SH-1	1
5.	Control valve (see inset)	--	--	--	--	--	--	--	--	--	--
6.	Flex connector w/ adapter	CK-5-SP	1	CK-5-SP	1	CK-5-SP	1	CK-5-SP	1	CK-5-SP	1
7.	Damper clamp	DC-1	1	DC-1	1	DC-1	1	DC-1	1	DC-1	1
8.	Sand granules (natural gas) or Vermiculite granules (propane gas)	CS-10	1	CS-10	1	CS-12	1	CS-15	1	CS-15	1
		LF-15	1	LF-15	1	LF-15	1	LF-15	1	LF-15	1
9.	Glowing embers	EM-1	1	EM-1	1	EM-1	1	EM-1	1	EM-1	1

* = Propane models

The log set is purchased and packaged separately. Styles and sizes will vary depending upon the log set ordered. When ordering replacement parts; be sure to indicate your log set and burner model.

fire-parts.com

Note: Photos not to scale.

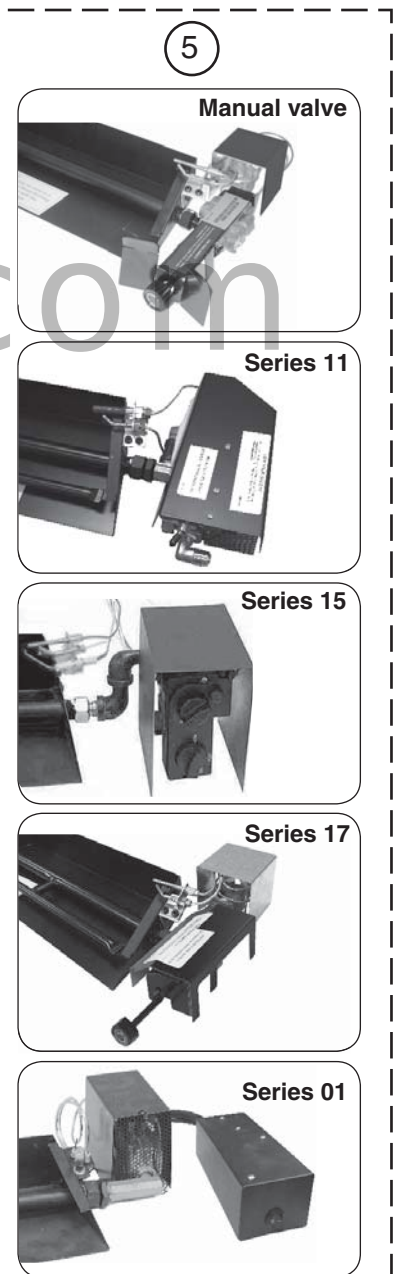
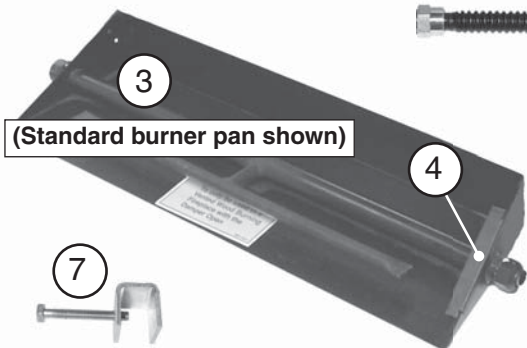
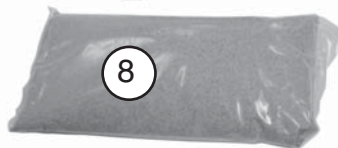
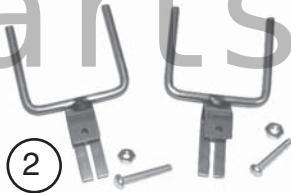
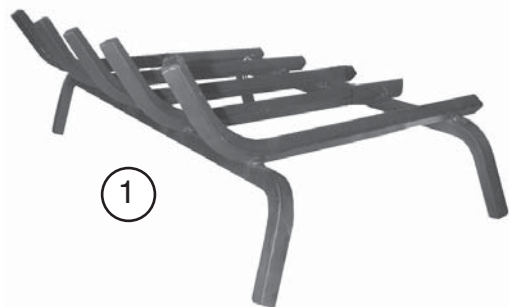

Replacement parts can be ordered from your local Real-Fyre® dealer.

For all valves, see detailed information on the following pages.

SAFETY CONTROL SYSTEM FOR MANUAL SERIES

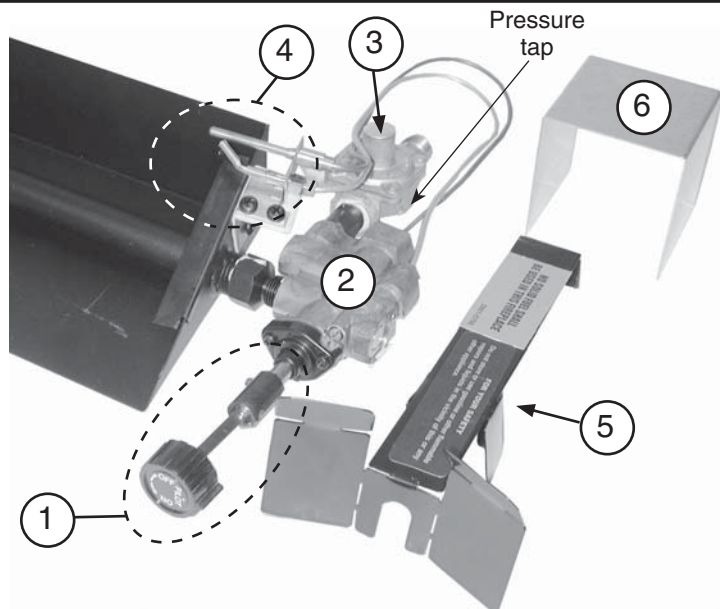

**DO NOT REMOVE
HEAT SHIELD**

Item	Description	Part No.	Qty.
1.	Control knob w/ extension	EH-11H	1
2.	Manual SPK valve	SV-19	1
3.	Pressure regulator, natural gas*	PR-1NAT	1
	or Pressure regulator, propane gas	PR-2LP	1
4.	Pilot assembly, natural gas	PT-1NAT	1
	or Pilot assembly, propane gas	PT-1LP	1
5.	Heatshield, valve	HS-32	1
6.	Heatshield, regulator	HS-39	1

* = PR-3NAT on 24"-36" models

SAFETY CONTROL SYSTEM FOR 17 SERIES

fire-parts.com

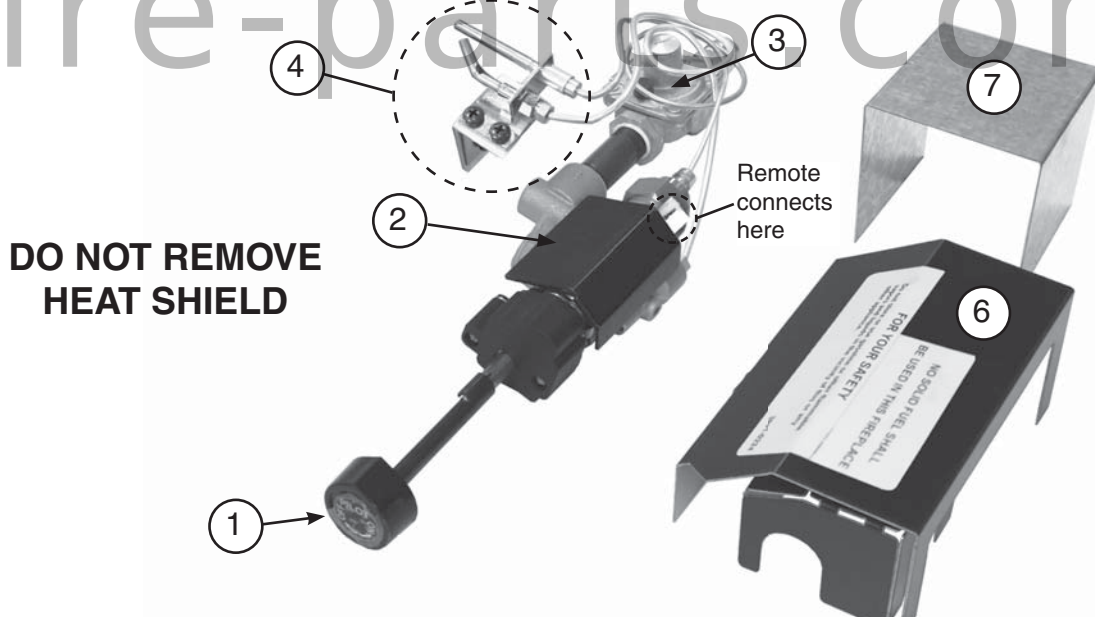

**DO NOT REMOVE
HEAT SHIELD**

Item	Description	Part No.	Qty.
1.	Control knob	KNOB-9	1
2.	Valve	SV-37	1
3.	Pressure regulator, natural gas*	PR-1NAT	1
	or Pressure regulator, propane gas	PR-2LP	1
4.	Pilot assembly, natural gas	PT-1NAT	1
	or Pilot assembly, propane gas	PT-1LP	1
5.	remote kit (if equipped)	VR-1A	1
6.	Heatshield, valve	HS-35	1
7.	Heatshield, regulator	HS-39	1

* = PR-3NAT on 24"-36" models



SAFETY CONTROL SYSTEM FOR 15 SERIES

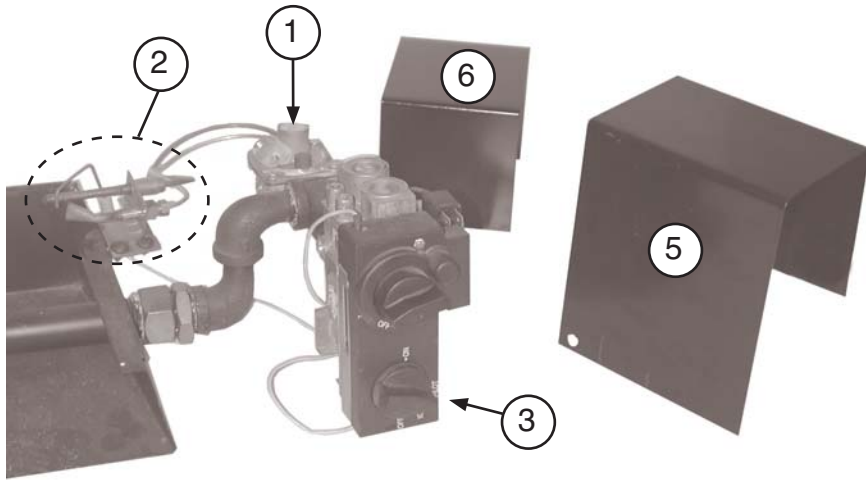

**DO NOT REMOVE
HEAT SHIELD**

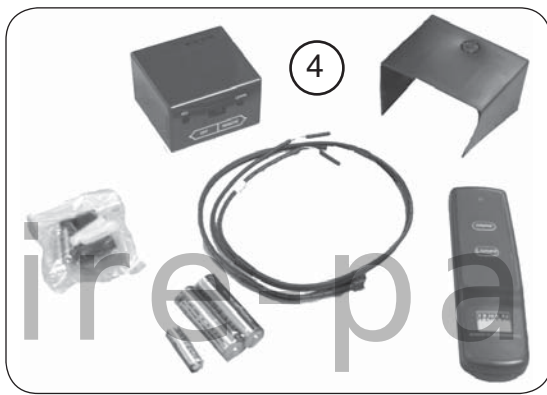

Item	Description	Part No.	Qty.
1.	Pressure regulator, natural gas or Pressure regulator, propane gas	PR-3NAT PR-2LP	1 1
2.	Pilot assembly (natural gas) or Pilot assembly (propane gas)	PT-1NAT PT-1LP	1 1
3.	Valve, natural gas or Valve, propane gas	SV-22 SV-23	1 1
4.	Remote kit (if equipped)	VR-1A	1
5.	Heat shield, valve	HS-31	1
6.	Heat shield, regulator	HS-41	1
7.	Decorative wood chunk	WC-1-5	1

SAFETY CONTROL SYSTEM FOR 01 SERIES

Item	Description	Part No.	Qty.
1.	Pilot assembly (natural) or Pilot assembly (propane)	PAC-6 PAC-7	1 1
2.	Valve assembly (natural) or Valve assembly (propane)	SV-32 SV-33	1 1
3.	Heat shield	HS-37	1
4.	Switch box assembly	IMP-1	1
5.	Remote kit (if equipped)	RR-1A	1

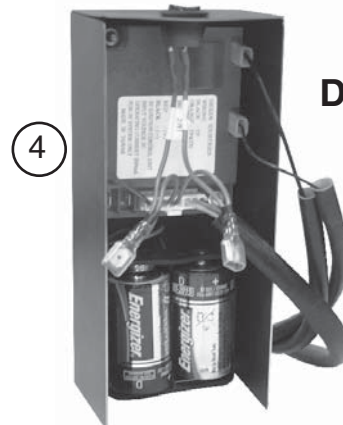
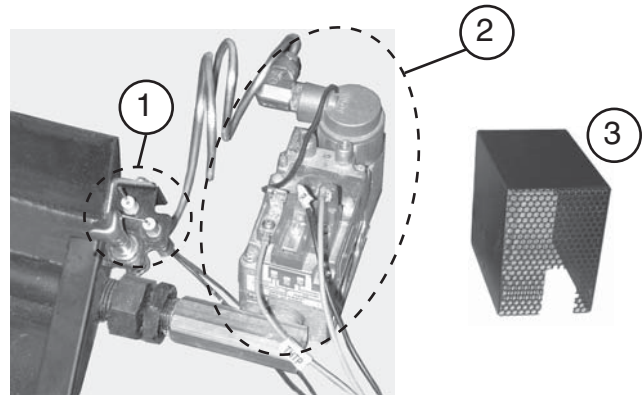

**DO NOT REMOVE
HEAT SHIELD**

SAFETY CONTROL SYSTEM FOR 11 SERIES

Item	Description	Part No.	Qty.
1.	Heatshield	HS-36	1
2.	Valve assembly (natural)	SV-6	1
or	Valve assembly (propane)	SV-6P	1
3.	Pilot assembly (natural)	PAC-3NAT	1
or	Pilot assembly (propane)	PAC-3LP	1
4.	Remote kit (if equipped)	RR-1A	1

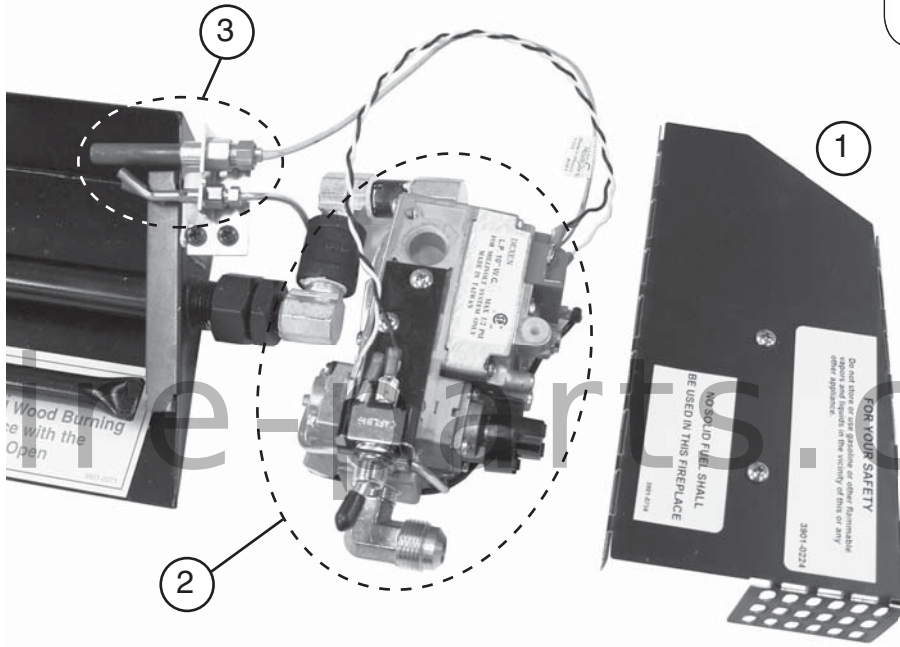

**DO NOT REMOVE
HEAT SHIELD**

L'INFORMATION DE SÛRETÉ IMPORTANTE DE PRÉINSTALLATION ET DE CHEMINÉE

- ATTENTION:** L'installation et la réparation doivent être faites par un NFI certifié ou tout autre installateur professionnel qualifié.
- Installateur:** Lisez soigneusement ces instructions avant d'installer ce système de brûleur à gaz. Soyez sûr que vous comprenez tous les mesures de sécurité et avertissements contenus en ce manuel.
- A.** Cet appareil est conçu comme appareil occupé. Les adultes doivent être présent quand cet appareil à gaz fonctionne. Ne laissez pas ce burning d'unité si sans surveillance ou tandis que n'importe qui dort.
 - B.** Cet appareil sert seulement avec le type de gaz indiqué de la plaque de contrôle. Cet appareil n'est pas CONVERTIBLE de CHAMP pour l'usage avec d'autres gaz.
 - C. FAITES ATTENTION: Sinon installé, entretenu, et utilisé correctement par ces instructions, ce produit peut causer le dommage corporel, les dégats matériels, ou les pertes humaines sérieux.**
 - D. AVERTISSEMENT:** Avant l'installation dans une cheminée plein-carburant-brûlante, la conduite de cheminée, l'amortisseur, et le foyer de cheminée doivent ÊTRE COMPLÈTEMENT NETTOYÉS de la suie, de la créosote, des cendres, et de la peinture lâche, et doivent être inspectés par un décapant qualifié de cheminée. Quelques cheminées plus anciennes peuvent ont besoin de réparation avant d'installer cet appareil.
 - E. VÉRIFIEZ LE TYPE de GAZ (normal ou propane) :** La fourniture de gaz doit être identique qu'indiquée de votre plaque de contrôle de système de brûleur. Si la fourniture de gaz est différente, **N'INSTALLEZ PAS**. Contactez votre revendeur pour l'aide immédiate.
 - F.** Gardez le domaine du clair réglé de notation de gaz et libérez des matériaux combustibles, l'essence, et d'autres vapeurs et liquides inflammables.
 - G. LA PRESSION DE GAZ INSUFFISANTE GARDERA LE PILOTE DU FONCTIONNEMENT CORRECTEMENT (SI ÉQUIPÉ). N'EMPLOYEZ PAS SI LA PRESSION DE GAZ EST INFÉRIEURE À LA CONDITION MINIMUM.**
 - H.** L'admission minimum gaz-fournissent la pression aux fins de l'ajustement d'entrée est 5" ; colonne d'eau (w.c.) sur le gaz naturel et le 11" ; w.c. sur le gaz de propane. La pression de gaz insuffisante affectera l'opération appropriée du pilote (si équipé). N'installez pas cet appareil à gaz si la pression minimum n'est pas disponible. L'admission maximum gaz-fournissent la pression est 10.5" ; w.c. sur le gaz naturel et le 13" ; w.c. sur le gaz de propane. La source de propane doit être réglée. (Ne reliez pas cet appareil directement à un réservoir de gaz non réglé de propane - ceci peut causer une explosion.)
 - I. Le système sifflant de gaz doit être classé pour fournir la pression d'admission minimum au débit maximum (BTU/hr).** La perte de pression anormale se produira si la pipe est trop petite, ou la course est trop longue. La pipe de fourniture de gaz doit être 1/2" ; diamètre intérieur minimum. Si la ligne de gaz est plus longue que 20' ; une ligne de plus grand diamètre peut être nécessaire. Reportez-vous aux directives NFPA 54 pour plus de détails.
 - J.** Les estimations d'entrée montrées en Btu par heure sont pour des altitudes jusqu'à 2.000 pi. Pour des altitudes au-dessus de 2.000 pi, référez-vous au code national de gaz de carburant ou entrez en contact avec le fabricant avant d'installer ce produit.
 - K.** Cet appareil à gaz et son clapet à gaz principal doivent être disconnected du gaz-fournissent le système sifflant pendant tout vérificateur de pression de ce système aux pressions d'essai au-dessus de 1/2 psig.
 - L.** Cet appareil à gaz doit être isolé dans gaz-fournissent le système sifflant en fermant le robinet d'isolement d'équipement relié au gaz-fournissent la ligne pendant tout vérificateur de pression du gaz-fournissent le système sifflant aux pressions d'essai égales à ou moins d'à 1/2 psig.
 - M.** N'employez pas cet appareil si n'importe quelle partie a été sous-marine. Appelez immédiatement un technicien qualifié de service pour inspecter l'appareil et pour remplacer n'importe quelle partie du système de contrôle et de n'importe quelle commande de gaz qui a été sous-marine.
 - N. Una pantalla de la chimenea debe ser en el lugar cuando el sistema está quemando.** Las provisiones para el aire de combustión adecuado deben ser mantenidas. A menos que otras provisiones para el aire de combustión se proporcionen, la pantalla tendrá una abertura para la introducción de aire de combustión. El aire de combustión es adecuado cuando todas las llamas se encrespan en la chimenea y lejos de la pantalla. **Cuando se utiliza un recinto de cristal de la chimenea (puerta), deje las puertas completamente abiertas cuando el sistema es en funcionamiento.**
 - O.** Cet appareil peut être installé dans un marché des accessoires, maison (mobile) de manière permanente située et manufacturée, où non interdit par des codes locaux. L'installation des appareils a conçu pour la maison manufacturée (États-Unis seulement) ou installation de caravane résidentielle doit se conformer au CAN/CSA standard Z240 MH, logement mobile, au Canada, ou à la construction et au standard de sécurité à la maison manufacturés, intitulent 24 CFR, la partie 3280, aux Etats-Unis, ou quand une telle norme ne s'applique pas, à ANSI/NCSBCS A225.1/NFPA 501A, installations à la maison manufacturées standard.

IMPORTANT PRE-INSTALLATION AND FIREPLACE SAFETY INFORMATION

- CAUTION:** Installation and repair must be done by an NFI Certified or other qualified professional installer.
- Installer:** Carefully read these instructions before installing this gas burner system. Be sure you understand all safety precautions and warnings contained in this manual.
- A.** This appliance is designed as an **attended appliance**. Adults must be present when this gas appliance is operating. Do not leave this unit burning when unattended or while anyone is sleeping.
 - B.** This appliance is only for use with the type of gas indicated on the rating plate. This appliance is **NOT FIELD CONVERTIBLE** for use with other gasses.
 - C. BE CAREFUL: If not installed, serviced, and used correctly per these instructions, this product can cause serious personal injury, property damage, or loss of life.**
 - D. WARNING:** Before installing in a solid-fuel-burning fireplace, **the chimney flue, damper, and firebox must be thoroughly CLEANED** of soot, creosote, ashes, and loose paint, and must be inspected by a qualified chimney cleaner. Some older fireplaces may need repair prior to installing this appliance.
 - E.** CHECK GAS TYPE (natural or propane): The gas supply must be the same as stated on your burner system rating plate. If gas supply is different, **DO NOT INSTALL**. Contact your dealer for immediate assistance.
 - F.** Keep the area of the gas burner system clear and free from combustible materials, gasoline, and other flammable vapors and liquids.
 - G.** INSUFFICIENT GAS PRESSURE WILL KEEP THE PILOT (IF EQUIPPED) FROM OPERATING PROPERLY. DO NOT USE IF GAS PRESSURE IS LOWER THAN THE MINIMUM REQUIREMENT.
 - H.** The *minimum* inlet gas-supply pressure for purposes of input adjustment is **5" water column (w.c.) on natural gas and 11" w.c. on propane gas**. Insufficient gas pressure will affect proper operation of the pilot (if equipped). Do not install this gas appliance if minimum pressure is not available. The *maximum* inlet gas-supply pressure is **10.5" w.c. on natural gas and 13" w.c. on propane gas**. The propane source must be regulated. (Do not connect this appliance directly to an unregulated propane gas tank - this can cause an explosion.)
 - I. The gas piping system must be sized to provide minimum inlet pressure at the maximum flow rate (BTU/hr).** Undue pressure loss will occur if the pipe is too small, or the run is too long. Gas supply pipe must be 1/2" minimum interior diameter. If the gas line is longer than 20', a larger diameter line may be necessary. Refer to the NFPA 54 guidelines for further details.
 - J.** Input ratings shown in BTU per hour are for elevations up to 2,000 ft. For elevations above 2,000 ft., refer to the National Fuel Gas Code or contact manufacturer before installing this product.
 - K.** This gas appliance and its main gas valve must be disconnected from the gas-supply piping system during any pressure testing of that system at test pressures in excess of 1/2 psig.
 - L.** This gas appliance must be isolated from the gas-supply piping system by closing the equipment shutoff valve connected to the gas-supply line during any pressure testing of the gas-supply piping system at test pressures equal to or less than 1/2 psig.
 - M.** Do not use this appliance if any part has been underwater. Immediately call a qualified service technician to inspect the appliance and to replace any part of the control system and any gas control that has been underwater.
 - N. A fireplace screen must be in place when the system is burning.** Provisions for adequate combustion air must be maintained. Unless other provisions for combustion air are provided, the screen shall have an opening(s) for introduction of combustion air. Combustion air is adequate when all flames curl into the fireplace and away from the screen. **When a glass fireplace enclosure (door) is used, leave the doors fully open when the system is in operation.**
 - O.** This appliance may be installed in an aftermarket, permanently located, manufactured (mobile) home, where not prohibited by local codes. Installation of appliances designed for manufactured home (U.S. only) or mobile home installation must conform with the Standard *CAN/CSA Z240 MH, Mobile Housing*, in Canada, or with the *Manufactured Home Construction and Safety Standard, Title 24 CFR, Part 3280*, in the United States, or when such a standard is not applicable, *ANSI/NCSBCS A225.1/NFPA 501A, Manufactured Home Installations Standard*.

IMPORTANT INFORMATION

Do not use this log set if any part has been underwater. Immediately call a qualified professional service technician to inspect the appliance and to replace any part of the control system and any gas control which has been underwater.

The gas log set must be isolated from the gas supply piping system by closing its individual shut-off valve during any pressure testing of the gas supply system at test pressures equal to or less than 1/2 psig. The gas log set and its individual shut-off valve must be disconnected from the gas supply piping system when testing at pressures in excess of 1/2 psig.

Keep the area of the gas log set clear and free from combustible materials, gasoline, and other flammable vapors and liquids.

FIREPLACE SIZE REQUIREMENTS

Burner size	Min. Fireplace Dimensions				BTU	
	Width		Depth	Height	NAT.	L.P.
	Front*	Rear				
16/19"	29"	23"	11"	18"	40k	30k
18/20"	30"	24"	14"	18"	70k	45k
24"	34"	28"	14"	18"	90k	65k
30"	40"	34"	15"	18"	95k	75k
36"	46"	40"	16"	18"	95k	75k

* This required width allows for centering of the log set.

Note: Rear width is at corresponding depth.

Minimum Free Opening Area of Chimney Damper for Venting (sq. in.)										
	For Factory-Built Fireplaces					For Masonry-Built Fireplaces				
Chimney	16/19"	18/20"	24"	30"	36"	16/19"	18/20"	24"	30"	36"
15' (min.)	18	33	46	47	47	27	44	55	57	57
20'	15	27	38	41	41	24	40	50	52	52
25'	13	23	32	35	35	-	-	-	-	-
30'	12	21	29	32	32	22	36	45	47	47

Note: The minimum chimney height from hearth to top of chimney is 15'.

THE FOLLOWING LOG STYLES ARE COMPATIBLE WITH THE G45 BURNER SYSTEM:

RDP: Golden Oak Designer Plus	BD: Royal English Oak Designer	CHB: Charred Royal English Oak
FO: Forest Oak	HD: Heritage Oak Designer	CHF: Charred Forest Oak
FOS: Forest Split Oak	W: White Birch	CHN: Charred Northern Oak
CR: Cedar	WCF: Western Campfyre	NO: Noble Oak
ACR: Aged Cedar	CHD: Charred Oak	R: Golden Oak
RED: Red Oak	CHS: Charred Split	RRO: Rugged Oak
S: Split Oak	CHRED: Charred Red Oak	PO: Post Oak
SDP: Split Oak Designer Plus	CHCR: Charred Cedar	B: Royal English Oak
RRSO: Rugged Split Oak	CHACR: Charred Aged Cedar	H: Heritage Oak
WO: Woodland Oak	CHRRSO: Charred Rugged Split Oak	CDR: Coastal Driftwood

Important: For safe operation and proper performance and to comply with CSA Certification, ONLY Robert H. Peterson parts and accessories must be used with this gas log set.

The minimum inlet gas supply pressure for purpose of input adjustment is 5" for natural gas and 11" for propane gas. Maximum inlet gas supply pressure for this burner is 10.5" for natural and 13" for propane gas.

A fireplace screen must be in place when the system is burning. Provisions for adequate combustion air must be maintained. Unless other provisions for combustion air are provided, the screen shall have an opening(s) for introduction of combustion air. Combustion air is adequate when all flames curl into the fireplace and away from the screen. **When a glass fireplace enclosure (door) is used, leave the doors fully open when the system is in operation.**

The minimum firebox dimensions in which log set is certified to be installed, is listed in the Technical Data Table here.

Note: For remote ready units, the maximum BTU thru put of some valves may vary.

IMPORTANT

For all valves, the air **MUST** be purged from the gas line before the pilot will light and burn properly. The time needed to purge will depend on the length of the gas line to the unit and the amount of time since the unit or gas line was last used. It may take several minutes before all the air is purged and the pilot will light and burn properly. Follow the LIGHTING INSTRUCTIONS section in this manual.

INSTALLATION

The damper clamp with hex bolt (Fig. 11-1) is provided as a means to prevent full closure of the damper blade. The clamp is easily attached to most damper blades with pliers or a wrench, and must be permanently installed. The clamp is designed to prevent accidental closure of the damper when installed as illustrated (Fig. 11-2 and Fig. 11-3). Should the clamp not fit, or fail to provide the permanent vent opening listed in the table found above, have a permanent stop installed, remove the damper blade, or have the damper cut to provide the minimum permanent opening required.

Note: These are minimum damper opening specifications. The damper must be completely opened when operating this gas appliance to achieve the best ventilation possible.

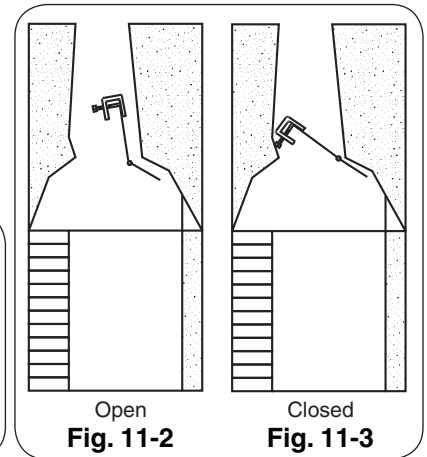
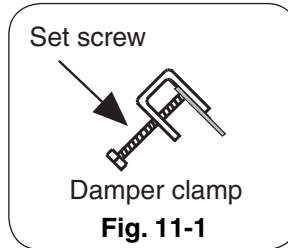

INSTALLING THE BURNER

The Real-Fyre gas log set must be installed by a qualified professional service technician. Instructions must be followed carefully to ensure proper performance and full benefit from the gas log set. **Check to be sure the log set is designed and labeled for the type of gas (natural or propane gas) supplied to the fireplace. Fireplace floor must be level, clean, and smooth.**

WARNING: Failure to position the parts in accordance with these diagrams or failure to use only parts specifically approved with this appliance may result in property damage or personal injury. REFER TO THE PARTS LIST WHEN FOLLOWING THESE INSTRUCTIONS.

1. MAKE SURE THE FIREPLACE GAS SUPPLY IS TURNED OFF.
2. Locate the gas-supply stub inside the fireplace and remove the cap, if attached (see Fig. 11-4).

CAUTION: When removing the cap, make sure the stub does not turn, loosening the connection inside the wall.

3. Attach the nut end of the flex connector to the adapter found on the valve or, if attached, on the regulator behind the valve. Tighten securely.
4. Place the burner system into the fireplace so the open burner pan faces outward.
5. Locate the grate and attach the log locators to the 2 outer bars of the grate with screws and nuts. The log locators should be loosely positioned toward the middle of the bars with screw slots facing towards fireplace side walls (Fig. 11-5). Temporarily place the front log at the front of the grate, to correctly determine the log locator position. Slide the log locators up against the rear of the front log. Tighten the log locators in place. Remove the front log.
6. Place the grate over the burner pan so the log locator brackets fit over the back edge of the burner pan to lock it in position.
7. Center this assembly in the fireplace and place it as far back in the fireplace as possible. Remove the grate for the gas connection and granule/ember placement.

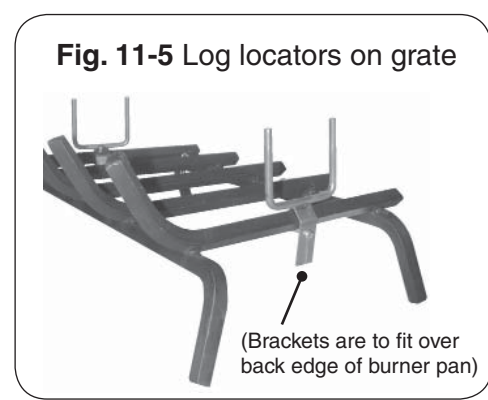
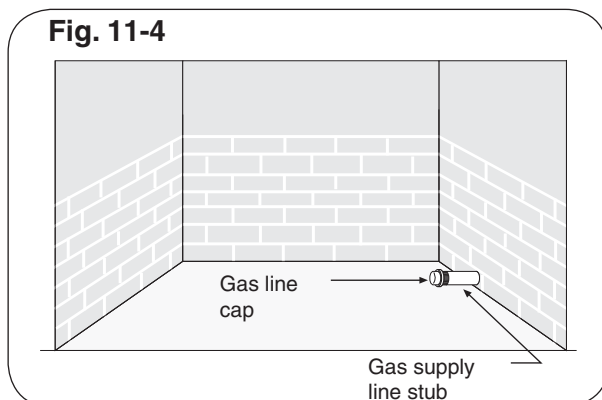

INSTALLATION (cont.)

- 8. Be sure gas to the fireplace is off.** Attach the large adapter end of the flex connector to the gas-supply stub using a pipe compound resistant to all gases. Ensure adapter (and nut) are tightened securely. Ensure the pan rests level on the fireplace floor after connection. Adjust the pan if necessary.
- 9. LEAK TEST:** Turn on the fireplace gas supply, and test at all connections for leaks using the appropriate soapy water solution. If bubbles appear, a leak is present. Turn off the gas and tighten at all connections. Repeat until no leaks are present. If a leak persists, turn off the gas supply and contact the local gas company or dealer. **NEVER USE A FLAME TO CHECK FOR LEAKS.**

Turn off the gas supply prior to proceeding.

- 10.** Place the heatshield over the regulator and/or valve.

Important: Heatshields must be in place during operation of the gas log set. Overheating of the valve will cause shut down of the gas log set or other operating problems.

- 11.** If this unit was shipped with a remote, read and follow the separate remote instructions (packed with remote) for complete remote installation.

GRANULE, EMBER, AND GRATE PLACEMENT

GRANULE PLACEMENT

The granules supplied with the unit are specially selected for use with either propane gas or natural gas. They maximize flame distribution and reduce carbon buildup.

- Fill the burner pan completely with the granules*. See Fig. 12-1. **Avoid spilling the granules on the pilot kit.**

***Note:** Use only select sand for natural gas burners and vermiculite for propane gas burners.

- Slope the granules at the same angle as the burner pan. This is important to ensure quiet lighting and even flame distribution.

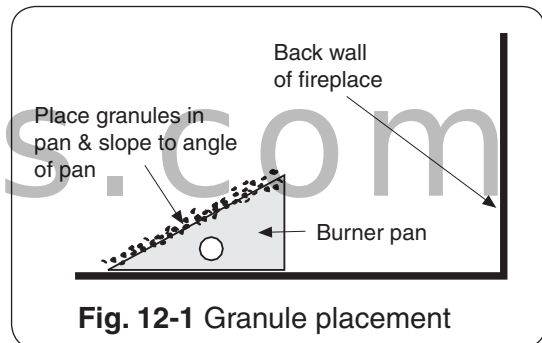

Fig. 12-1 Granule placement

EMBER PLACEMENT

Sprinkle the glowing embers lightly and evenly over the entire surface of the granules. **Break up any clumps that may have developed during shipment.** (For Charred series log sets, refer to OPTIONAL CHARRED SERIES INSTALLATION section.)

Important: Do not add any additional embers to this log set. Any additional embers may cause unsafe operation.

GRATE PLACEMENT

Replace the grate so that the bottom tabs on the log locator brackets fit over the back edge of the pan, locking it in position.

01 VALVE MODELS ONLY

CONNECTING THE IGNITION PACK TO THE VALVE

The 01 valve comes complete with the wiring harness connected to the switch box. You may wish to ensure it is correctly connected before finally connecting the three wires to the valve, as below.

TO CHECK THE WIRING ASSEMBLY:

- Check that the wiring harness is fitted tightly into the connector on the green ignitor pack inside the switch box (Fig. 13-1).
- Check that the female connectors on the two black wires from the pilot assembly (wires marked "I" and "S") are inserted fully into the male connectors on the ignitor pack (Fig. 13-2).
- Check the connection of the red and black wires of the wire harness to the respective counterpart wires from the battery holder (red-red and black-black). The two brown wires should be connected to the switch.

Note: The two spare brown wires with coated male connectors are used to connect a remote system (if equipped).

- Connect the wires to the valve in the following order (see Fig. 13-2):

Orange wire marked **THTP** - to **THTP** connector on valve

Black wire marked **TP** - to **TP** connector on valve

Green wire marked **TH** - to **TH** connector on valve

The diagram below shows the wiring layout for the complete unit.

INSTALLING OR REPLACING BATTERIES FOR IGNITION MODULE PACK

Two 1.5-volt (D-cell) alkaline batteries are supplied with the burner system. To install or replace batteries, remove any old batteries (if applicable) and install new batteries according to the diagram illustrated on the battery holder mounted inside the switch box (Fig. 13-3).

Note: For the system to work properly, it is suggested that you replace the batteries annually with fresh batteries. Always replace all the batteries at the same time.

SWITCH BOX PLACEMENT

Place the switch box outside of the firebox and a minimum of 6" from the burner/flame. If the switch box is in the firebox, the switch box must only be oriented as shown in Fig. 13-4. The switch box must not be placed in the rear of the fireplace, or in any other manner than shown in Fig. 13-4. Set the box on its side and place the bottom of the box toward the right firebox wall (box must be a minimum of 6" from the burner/flame). Be sure that the pilot and valve wire bundles remain clear of the burner, valve, and heat shield at all times.

Note: Coil excess wire within the switch box.

CAUTION: THE SWITCH BOX MAY BE HOT DURING AND AFTER OPERATION.

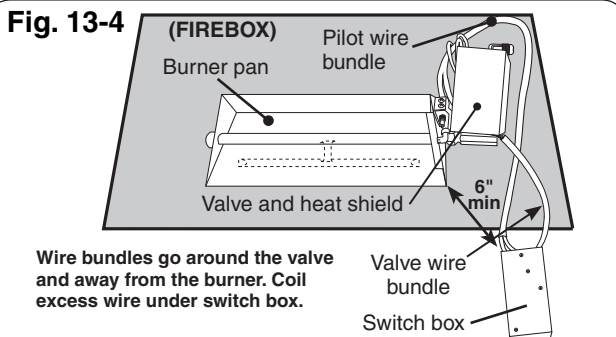
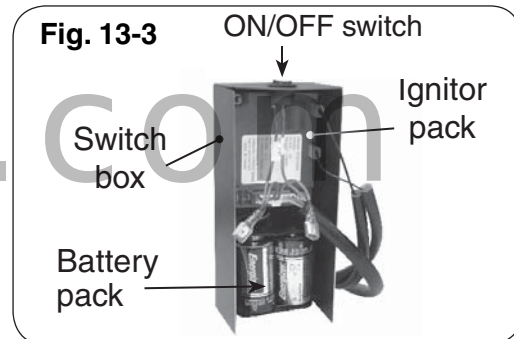
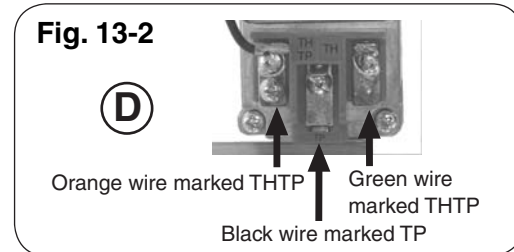
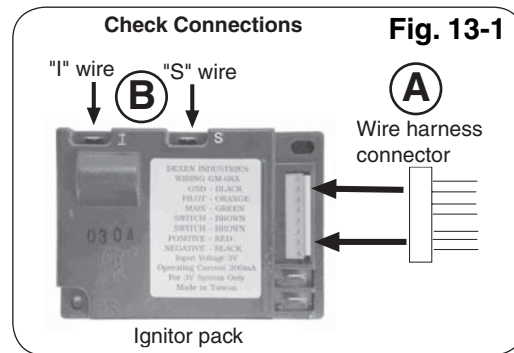

IF SWITCH BOX IS INSIDE FIREBOX; ORIENT ONLY AS SHOWN BELOW:

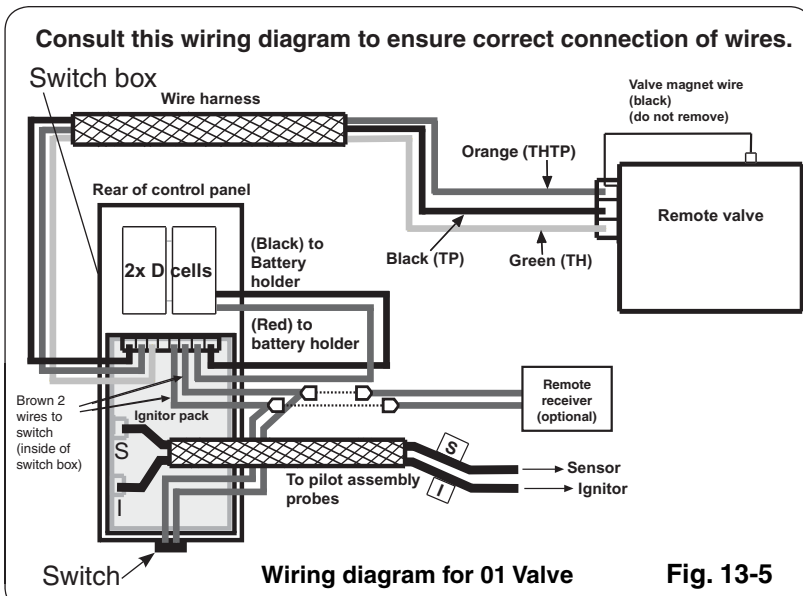
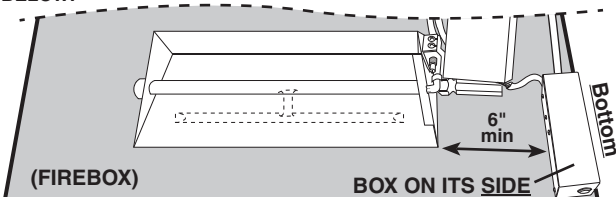

LOG PLACEMENT

The log set is purchased and packaged separately. Woodland Oak log set (WO) shown here. Styles and sizes will vary depending upon the log set ordered. If the log set ordered includes placement instructions; follow those instructions. When ordering replacement parts; be sure to indicate your log set and burner model.

Note: For Charred series, see the following section.

Proper log placement is important to ensure proper performance of the Real-Fyre® gas log set. Be sure to follow the LOG PLACEMENT INSTRUCTIONS carefully. Three optional log placement patterns, an exclusive feature of the log set, are explained below.

FOR ALL OPTIONS

Step 1: Place the rear bottom log (Log #1) on the back of the grate (Fig. 14-1), and slide it forward against the log locators. Place the front log (Log #2) on the front of the grate and slide it back against the log locators. The log locators ensure that adequate space between the logs is maintained for a cleaner burn.

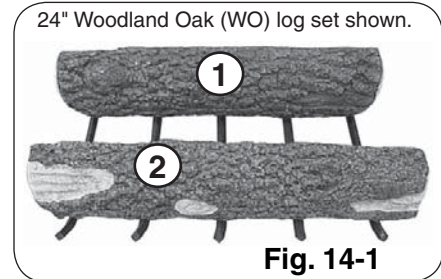

OPTION 1

Step 2: Place the middle log (Log #4) to rest on the front and rear bottom logs, as shown in Fig. 14-2. Place Log #3 so it rests on Log #4 and the front log, as shown in Fig. 14-2. Ensure they are placed across the space between the logs.

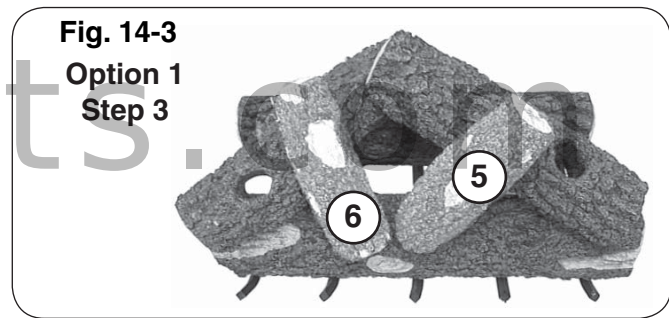
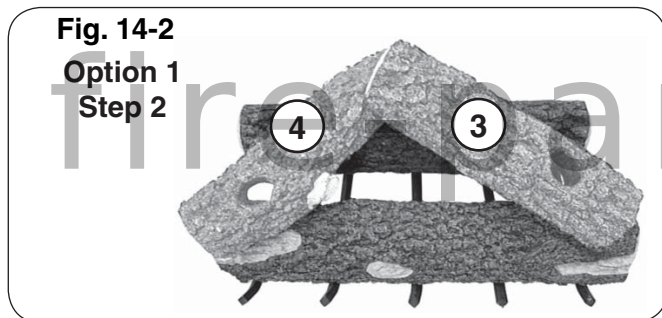

OPTION 2

Step 2: Place the middle logs parallel, as shown in Fig. 14-4. Log #3 is placed with one end on the front log, and the other end resting on Log #4.

Step 3: Place Log #5 resting on the front log and the left middle log, and Log #6 resting on the rear log and the right middle log, as shown in Fig. 14-4.

OPTION 3

Step 2: Place the middle logs (Logs #3 & #4) so they are parallel, resting on the front and rear logs across the space, as shown in Fig. 14-5.

Step 3: Place top Logs #5 & #6 so they are parallel and rest across Logs #3 & #4, as shown in Fig. 14-5.

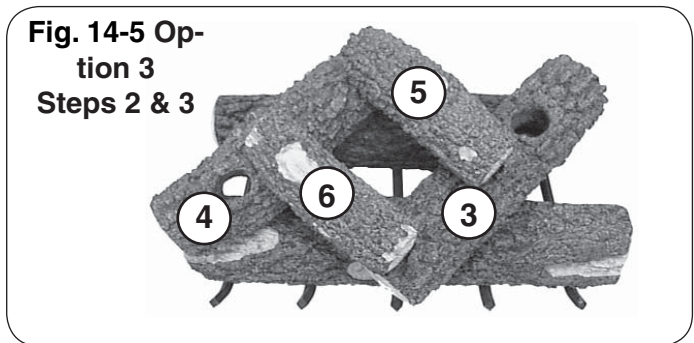
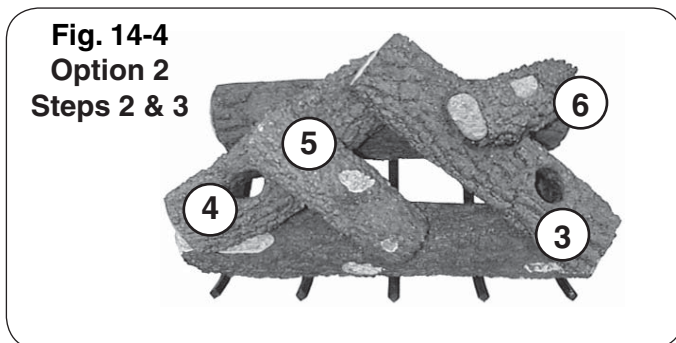

CAUTION: Burn hazard. Logs will remain hot for some time after use. You must maintain the log layout as shown to ensure proper operation of the log set. If you need to reposition any log to maintain the proper layout, use heat-resistant gloves or allow logs adequate time to cool before handling.

CHARRED LOG PLACEMENT

SCREEN AND EMBERS PLACEMENT

Attach the ember bed (Part No. CHD-01) to the burner by slipping it onto the back edge (center left to right) with the perforated section facing towards the back fireplace wall (Fig. 15-1).

Cover the surface of the ember bed with the glowing embers supplied with the Charred series log set, as shown in Fig. 15-2.

Note: For best glowing performance, they should be applied evenly and pulled slightly apart so the fibers are somewhat loose.

Important: It is not necessary to pile the entire bag of the glowing embers. More glowing embers may be added after completion of the entire installation.

Fig. 15-1

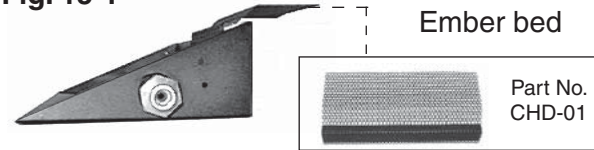
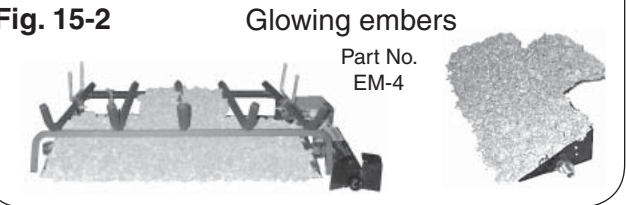

Fig. 15-2



LOG PLACEMENT

The log set is purchased and packaged separately. Charred Split Oak log set (CHS) shown here. Styles and sizes will vary depending upon the log set ordered. If the log set ordered includes placement instructions; follow those instructions. When ordering replacement parts; be sure to indicate your log set and burner model.

Step 1. Place the long bottom rear log (log #2) on the back of the grates with the flat, featureless side facing the rear of the fireplace. Slide it forward to touch the log locator.

Step 2. The two sections of the front log (logs #1A & 1B) are placed on the front of the grate with the charred sections facing each other and approximately 1" apart at the top (Fig. 15-3). Slide them back against the log locators.

Note: The log locators ensure that adequate space between front and rear logs are maintained for a cleaner burn.

Step 3. Place the two curved logs (logs #3 & #4) so that one end rests on each front log section (logs #1A & 1B) and the other end rests on the rear log (log #2).

Note: The charred sections should be over the opening between the front and rear logs (Fig. 15-4).

Step 4. Place the small top charred logs (logs #5 & #6) so they rest over the charred sections of the front bottom log sections (logs # 1A & 1B) and on the two curved logs (logs #3 & #4) (Fig. 15-5).

Step 5. Place the curved top charred log (log #7) to rest on the two top logs at rear, but not encroaching into the space between rear and front logs (Fig. 15-6).

Note: The additional top log (log #7) is not available with 18" log sets.

Fig. 15-3



Fig. 15-4

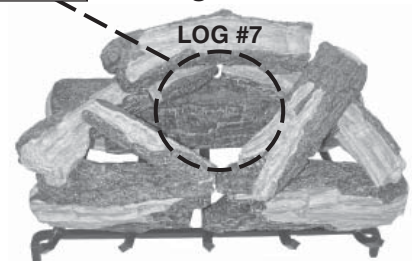

Fig. 15-5



MAINTAIN A SPACE IN THE CENTER OF THE LOGS AT ALL TIMES

Fig. 15-6



INSTRUCTIONS D'ÉCLAIRAGE - PILOTE ET VALVE MANUELS DE LA SÉRIE 17

POUR VOTRE SÛRETÉ, LISEZ AVANT DE S'ALLUMER

AVERTISSEMENT: Si vous ne suivez pas ces instructions exactement, un incendie ou une explosion peut résulter entraînant des dégâts matériels, des blessures ou la perte de la vie.

N'employez pas cet appareil si n'importe quelle partie a été sous-marine. Réclamez immédiatement un technicien de service professionnel qualifié et pour inspecter l'appareil et pour remplacer n'importe quelle partie du système de commande et de n'importe quelle commande de gaz qui a été sous l'eau.

Le Vrai-Fyre système de brûleur a un pilote qui peut être allumé à la main en utilisant une allumette ou un allumeur. En allumant le pilote, suivez ces instructions exactement.

AVANT DE S'ALLUMER, sentez tous autour du secteur de brûleur pour le gaz. Soyez sûr de sentir à côté du plancher car un certain gaz est plus lourd que l'air et arrangez sur le plancher. SI VOUS SENTEZ LE GAZ, SUIVEZ LES INSTRUCTIONS À LA P. 1.

Utilisez seulement votre main pour enfoncer ou pour tourner le bouton de commande de gaz. N'utilisez jamais les outils. Si le bouton n'enfoncera pas ou ne tournera pas à la main, n'essayez pas de le réparer. Appelez un technicien de service professionnel qualifié et. La force ou la réparation essayée peut avoir comme conséquence l'incendie ou l'explosion.

ALLUMER LE PILOTE

1. Si le bouton de soupape de commande de brûleur n'est pas dans la position de **OFF**, enfoncez la poignée de commande de gaz légèrement et tournez-vous dans le sens des aiguilles d'une montre ↻ vers **OFF** (fig. 16-1).

Note: Le bouton de commande de brûleur ne peut pas être tourné du **PILOT** au **OFF** à moins que la poignée soit enfoncée légèrement. Ne forcez pas.

Attendez cinq minutes pour dégager dehors n'importe quel gaz. Si vous sentez alors le gaz, ARRÊTEZ ! Informez votre fournisseur de gaz ou le département de feu immédiatement. Si vous ne sentez pas le gaz, passez dessus à l'étape 2.

2. Tournez le bouton de commande de brûleur dans le sens contraire des aiguilles d'une montre ↺ au **PILOT** (fig. 16-1). Poussez la poignée de commande toute la manière dedans et tenez-la. Tenez une longue allumette de cheminée ou un proche plus léger le thermocouple pour allumer le pilote. Continuez à tenir le bouton de commande pour approximativement 30 secondes après que le pilote est allumé pour permettre au thermocouple de détecter la flamme pilote, puis libérez le bouton. Le pilote restera s'est allumé.

- Si le pilote ne s'allumera pas, répétez les étapes 1. et 2.
- Si le pilote ne restera pas s'allumait après que plusieurs essais, tournent la poignée de commande de gaz à **OFF** et appellent votre fournisseur de technicien ou de gaz de service.

ALLUMAGE DU BRÛLEUR PRINCIPAL

1. Assurez-vous que le pilote brûle.
2. Tournez la poignée de commande de gaz dans le sens contraire des aiguilles d'une montre ↺ à **ON** (fig. 16-1) pour mettre à feu le brûleur. Le brûleur mettra à feu.

Note: Examinez périodiquement la flamme pilote pour assurer le modèle approprié de flamme (Fig. 16-1).

ASSUREZ-VOUS QUE LE THERMOCOUPLE ET L'ASSEMBLÉE PILOTE SONT EN ALIGNEMENT CORRECT AVEC L'UN L'AUTRE (FIG. 16-1).

ROTATION OUTRE DU BRÛLEUR PRINCIPAL

1. De la position de **ON**, tournez le bouton de commande dans le sens des aiguilles d'une montre ↻ à la position **PILOT**. Le brûleur s'éteindra et le pilote restera s'est allumé.

S'ÉTEINDRE LE PILOTE

1. Si complet l'arrêt est désiré, de la position **PILOT**, de l'enfoncer le bouton de commande légèrement et du tour dans le sens des aiguilles d'une montre ↻ à la position de repos. Ne forcez pas le bouton. **NE FORCEZ PAS LE BOUTON.** Ceci exigera du pilote d'être re-s'est allumé avant d'utiliser le brûleur encore.

Le SPK-17 est capable de l'éclairage à distance. Si votre unité est équipée d'un extérieur, lisez et suivez les instructions à distance séparées d'actionner le brûleur à distance.

(valve manuelle montrée)

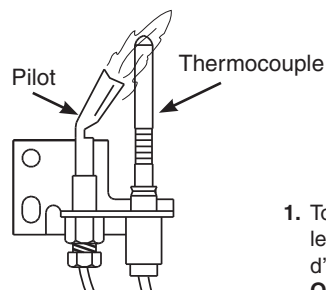
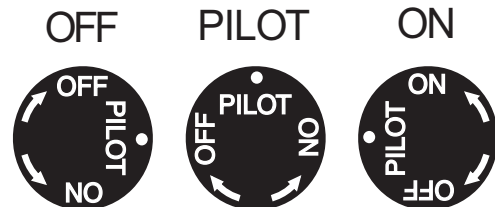

Fig. 16-1

1. S'ALLUMER - tournez le bouton de commande de brûleur à **OFF** ↻ et attendez 5 minutes avant de s'allumer.



1. Tournez le cadran dans le sens des aiguilles d'une montre ↻ à **OFF** seulement quand l'arrêt complet est nécessaire.
2. Tournez le cadran dans le sens contraire des aiguilles d'une montre ↺ à la position **PILOT**. Avec le bouton prêt de pression d'allumette dedans et la prise pendant 60 secondes tout en allumant le pilote.
3. Tournez le bouton contre- dans le sens des aiguilles d'une montre ↻ au brûleur léger.

LIGHTING INSTRUCTIONS - MANUAL PILOT AND SERIES 17 VALVE

FOR YOUR SAFETY, READ BEFORE LIGHTING

WARNING

If you do not follow these instructions exactly, a fire or explosion may result, causing property damage, personal injury, or loss of life.

Do not use this appliance if any part has been underwater. Immediately call for a qualified professional service technician to inspect the appliance and to replace any part of the control system and any gas control that has been underwater.

The Real-Fyre® burner system has a pilot that can be lit by hand using a match or lighter. When lighting the pilot, follow these instructions exactly.

BEFORE LIGHTING, smell all around the burner area for gas. Be sure to smell next to the floor, as some gas is heavier than air and will settle on the floor. **IF YOU SMELL GAS, FOLLOW THE INSTRUCTIONS ON P. 1.**

Use only your hand to push in or turn the gas control knob. Never use tools. If the knob will not push in or turn by hand, don't try to repair it. Call a qualified professional service technician. Excessive force or attempted repair may result in fire or explosion.

LIGHTING THE PILOT

1. Push in the gas control knob slightly and turn clockwise ↻ to **OFF** (Fig. 17-1). Refer to the PARTS LIST for the location of the burner control valve knob.

Note: The burner control knob cannot be turned from **PILOT** to **OFF** unless the knob is pushed in slightly. Do not force.

Wait five minutes to clear out any gas. If you then smell gas, **STOP!** Notify your gas supplier or the fire department immediately. If you don't smell gas, go on to step 2.

2. Turn the burner control knob counter-clockwise ↺ to **PILOT** (Fig. 17-1). Push the control knob **firmly and fully** in and hold. Hold a long fireplace match or lighter near the thermocouple to light the pilot. Continue to hold the control knob in for approximately 30 seconds after the pilot is lit, then release the knob. The pilot will remain lit.
- If the pilot will not light, repeat steps 1 and 2.
 - If the pilot will not stay lit after several tries, turn the gas control knob to **OFF** and call your service technician or gas supplier.

IGNITING THE MAIN BURNER

1. Make sure the pilot is burning.
2. Turn the gas control knob counterclockwise ↺ to **ON** (Fig. 17-1) to ignite the burner. The burner will ignite.

Note: Periodically check the pilot flame for the proper flame pattern (Fig. 17-1).

MAKE SURE THE THERMOCOUPLE AND PILOT ASSEMBLY ARE IN CORRECT ALIGNMENT WITH EACH OTHER (Fig. 17-1).

TURNING OFF THE MAIN BURNER

1. From the **ON** position, turn the control knob clockwise ↻ to the **PILOT** position. The burner will extinguish, and the pilot will remain lit.

EXTINGUISHING THE PILOT

1. If complete shutdown is desired, from the **PILOT** position, push in the control knob slightly and turn clockwise ↻ to the **OFF** position. **Do not force the knob.** This will require the pilot to be relit before using the burner again.

The series 17 valve is capable of remote operation. **If this unit was shipped with a remote, or if a remote system was installed later, read and follow the separate remote instructions to operate the burner remotely.**

(Manual valve shown)



1. Lighting - Turn the burner control knob to **OFF** ↻ and wait 5 minutes before lighting.

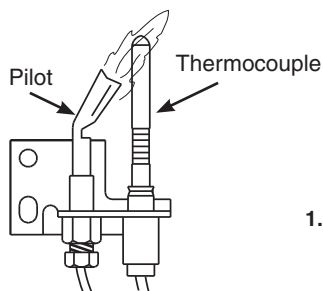

Pilot Assembly
Fig. 17-1

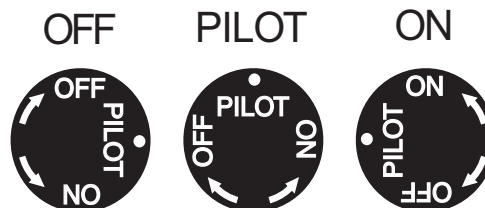

1. Turn the knob clockwise ↻ to **OFF** only when complete shutdown is desired or prior to lighting the pilot.
2. Turn knob counterclockwise ↺ to **PILOT** position. With match ready, press knob in and hold for 60 seconds while lighting pilot.
3. Turn the knob counterclockwise ↺ to **ON** to light the burner.

INSTRUCTIONS D'ÉCLAIRAGE - VALVE DE LA SÉRIE 15

POUR VOTRE SÛRETÉ, LISEZ AVANT DE S'ALLUMER

AVERTISSEMENT : Si vous ne suivez pas ces instructions exactement, un incendie ou une explosion peut résulter entraînant des dégâts matériels, des blessures ou la perte de la vie.

N'employez pas cet appareil si n'importe quelle partie a été sous-marine. Réclamez immédiatement un technicien de service professionnel qualifié et pour inspecter l'appareil et pour remplacer n'importe quelle partie du système de commande et de n'importe quelle commande de gaz qui a été sous l'eau.

Le Vrai-Fyre® système de brûleur a un pilote qui peut être allumé à la main en utilisant une allumette ou un allumeur. En allumant le pilote, suivez ces instructions exactement.

AVANT DE S'ALLUMER, sentez tous autour du secteur de brûleur pour le gaz. Soyez sûr de sentir à côté du plancher car un certain gaz est plus lourd que l'air et arrangez sur le plancher. SI VOUS SENTEZ LE GAZ, SUIVEZ LES INSTRUCTIONS À LA P. 1.

Utilisez seulement votre main pour enfoncer ou pour tourner le bouton de commande de gaz. N'utilisez jamais les outils. Si le bouton n'enfoncera pas ou ne tournera pas à la main, n'essayez pas de le réparer. Appelez un technicien de service professionnel qualifié et. La force ou la réparation essayée peut avoir comme conséquence l'incendie ou l'explosion.

ALLUMER LE PILOTE

1. Tournez le bouton de commande d'ignitor (Fig. 18-1) de la soupape de commande de brûleur au côté de la casserole de brûleur dans le sens contraire des aiguilles d'une montre ↺ de sorte que la partie de rétrécissement du bouton se déplace de la position de **OFF**, légèrement vers **IGN** jusqu'à atteindre l'arrêt.
2. Serrez le bouton de commande d'ignitor dedans et tenez dedans pendant 5 secondes (seulement le gaz pilote coulera).
3. Continuez d'enfoncer tout en tournant le dans le sens contraire des aiguilles d'une montre ↺ supplémentaire de bouton de commande d'ignitor, vers la position **PILOT**, jusqu'à ce que vous entendiez un clic. Le clic est une indication que l'ignitor de pizio a été activé.

Note: Si l'étincelle de l'ignitor de pizio n'allume pas le pilote, répétez les étapes 2 et 3 jusqu'au pilote lights.

4. Continuez à tenir le bouton de commande d'ignitor en position **PILOT** pour 60 secondes après que le pilote a été allumé pour permettre au thermocouple de détecter la flamme pilote.

Note: La flamme pilote devrait toujours être présent quand le système de brûleur est en fonction, et devrait juste envelopper le bout du thermocouple.

ALLUMAGE DU BRÛLEUR PRINCIPAL

1. Quand la flamme pilote est stable, libérez le bouton de commande d'ignitor et tournez-vous dans le sens contraire des aiguilles d'une montre ↺ vers la position de **ON** pour permettre le brûleur principal.
2. Tournez le bouton de commande de taille de flamme (Fig. 18-3) entièrement dans le sens contraire des aiguilles d'une montre ↺ pleinement la position de fonctionnement (Fig. 18-4) pour mettre à feu le brûleur chez BTUs maximum.

Après que le brûleur principal mette à feu, ajustez la taille de flamme comme indiqué ci-dessous.

AJUSTEMENT DE LA TAILLE DE FLAMMET

1. Pour ajuster la flamme, tournez le bouton de commande de taille de flamme (Fig. 18-3) dans le sens contraire des aiguilles d'une montre ↺ à la taille de flamme d'augmentation et dans le sens des aiguilles d'une montre ↻ à la taille de flamme de diminution jusqu'à ce que les flammes aient les caractéristiques désirées.
2. Quand vous êtes fini appréciant votre feu, tournez le bouton de commande de taille de flamme à **OFF**. Le pilote restera s'est allumé. Le système de brûleur peut être relit en tournant le bouton de commande de taille de flamme vers **ON**.

COUPER LE PILOTE

Si vous ne projetez pas sur employer votre système de brûleur pendant une période prolongée vous pouvez choisir de vous éteindre le pilote. Pour faire ceci, tournez le bouton de commande de taille de flamme jusqu'à la position de **OFF** et puis tournez le bouton de commande d'ignitor jusqu'à la position de **OFF** (Fig. 18-1).

Important: En fermant le système de brûleur complètement, tournez le bouton de control/ignition à la position de repos (Fig. 18-1). Si vous désirez tourner l'unité en arrière dessus, attendez une minute au minimum avant de commencer le procédé de rallumer (ALLUMANT LE PILOTE). Ceci permet à la soupape de sûreté de remettre à zéro en vue de rallumer.

Si cette unité était embarquée avec un extérieur, ou si un système à distance était installé plus tard, lisez et suivez les instructions à distance séparées d'actionner le brûleur à distance.

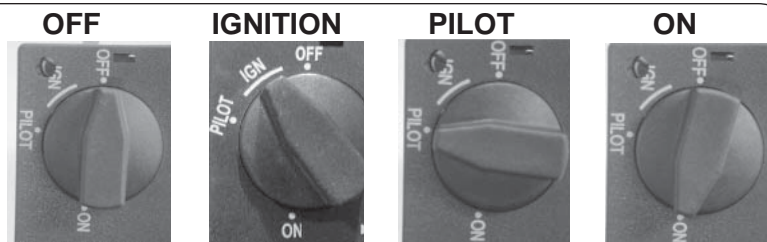

POSITIONS D'OPÉRATION DE CLAPET À GAZ
Fig. 18-1

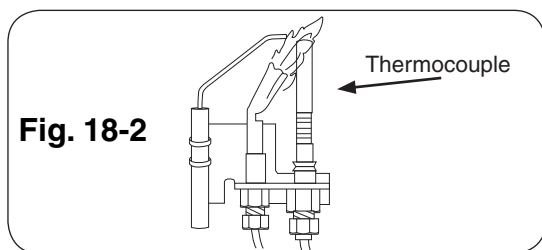

Fig. 18-2

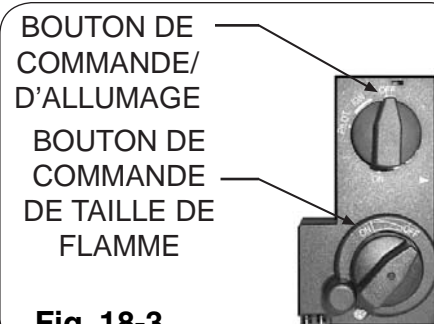

Fig. 18-3



OFF

Fig. 18-4

ON

LIGHTING INSTRUCTIONS - SERIES 15 VALVE

FOR YOUR SAFETY, READ BEFORE LIGHTING

WARNING

If you do not follow these instructions exactly, a fire or explosion may result, causing property damage, personal injury, or loss of life.



Do not use this appliance if any part has been underwater. Immediately call for a qualified professional service technician to inspect the appliance and to replace any part of the control system and any gas control that has been underwater.

The Real-Fyre® burner system has a pilot. When starting the pilot, follow these instructions exactly.

BEFORE LIGHTING, smell all around the gas burner system area for gas. Be sure to smell next to the floor, as some gas is heavier than air and will settle on the floor. IF YOU SMELL GAS, FOLLOW THE INSTRUCTIONS ON P. 1.

Use only your hand to push in or turn the gas control knob. Never use tools. If the knob will not push in or turn by hand, don't try to repair it. Call a qualified professional service technician. Force or attempted repair may result in fire or explosion.

LIGHTING THE PILOT



1. Turn the ignitor control knob (Fig. 19-1) on the burner control valve assembly to the side of the burner pan counterclockwise  so that the narrowing part of the knob moves from the **OFF** position, slightly toward **IGN**, until reaching the stop.
2. Press the ignitor control knob in and hold in for five (5) seconds (only pilot gas will flow).
3. Continue pressing in while turning the ignitor control knob further counterclockwise  toward the **PILOT** position until you hear a click. The click is an indication that the piezo ignitor has been activated.

Note: If the spark from the piezo ignitor does not light the pilot, repeat steps 2 & 3 until the pilot lights.

4. Continue to hold the ignitor control knob in the **PILOT** position for 60 seconds after the pilot has been lit to allow the thermocouple to detect the pilot flame.



Note: The pilot flame should always be present when the burner system is in operation, and should just envelop the tip of the thermocouple.

IGNITING THE MAIN BURNER

1. When the pilot flame is stable, release the ignitor control knob and turn counterclockwise  to the **ON** position to enable the main burner.
2. Turn the flame-height control knob (Fig. 19-3) counterclockwise  to the fully **ON** position

(Fig. 19-4) to ignite the burner at maximum BTUs. After the main burner ignites, adjust the flame height as indicated below.

ADJUSTING THE FLAME HEIGHT

1. To adjust the flame, turn the flame-height control knob (Fig. 19-3) counterclockwise  to increase the flame height, or clockwise  to decrease the flame height, until the flames have the desired characteristics.
2. When you are finished enjoying your fire, turn the flame-height control knob to **OFF**. The pilot will remain lit. The burner system can be relit by rotating the flame-height control knob toward **ON**.

SHUTTING OFF THE PILOT

If you do not plan on using your burner system for an extended period, you may elect to extinguish the pilot. To do this, rotate the flame-height control knob to the **OFF** position and then rotate the ignitor control knob to the **OFF** position (Fig. 19-1).

Important: When shutting the burner system down completely, turn the control/ignition knob to the **OFF** position (Fig. 19-1). If you desire to turn the unit back on, wait a minimum of one (1) minute before starting the relight procedure (LIGHTING THE PILOT). This allows the safety valve to reset in preparation for relighting.

If this unit was shipped with a remote, or if a remote system was installed later, read and follow the separate remote instructions to operate the burner remotely.

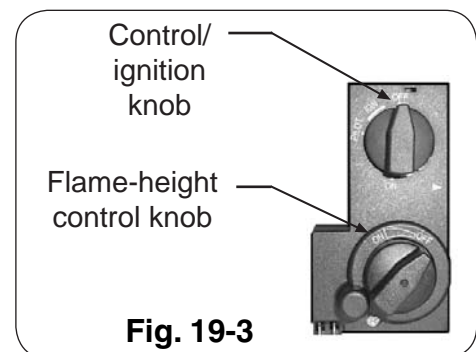
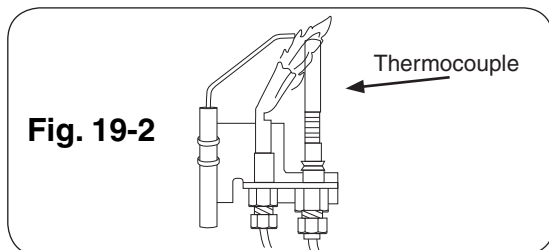
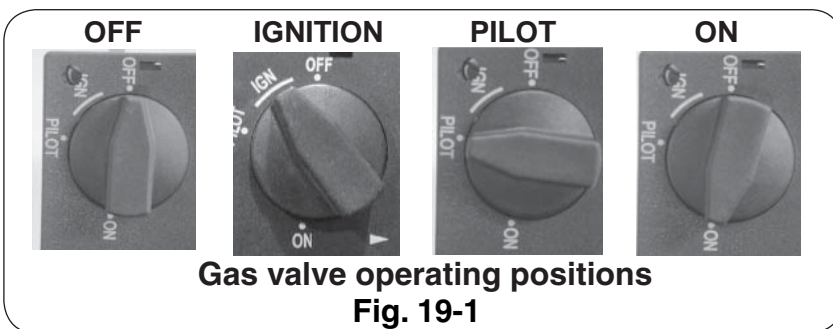

POUR VOTRE SÛRETÉ, LISEZ AVANT DE S'ALLUMER

AVERTISSEMENT

Si vous ne suivez pas ces instructions exactement, un incendie ou une explosion peut résulter, entraînant des dégâts matériels, des blessures, ou la perte de la vie.

AVANT DE S'ALLUMER, sentez tous autour du secteur de brûleur à gaz pour le gaz. Soyez sûr de sentir à côté du plancher parce qu'un certain gaz est plus lourd que l'air et arrangez sur le plancher. **SI VOUS SENTEZ LE GAZ, SUIVEZ LES INSTRUCTIONS À LA PAGE 1.**

- 1. ARRÊT!** Lisez l'information de sûreté ci-dessus.
- Arrêtez n'importe quel appareil électrique si utilisé avec le système de brûleur.
- Vérifiez le commutateur (marqué **I = mettez à feu** ; **O = au loin**) situé sur l'avant de la boîte de commutateur est placé au "**O**" ; (AU LOIN). Ne forcez pas.

Fig. 20-1

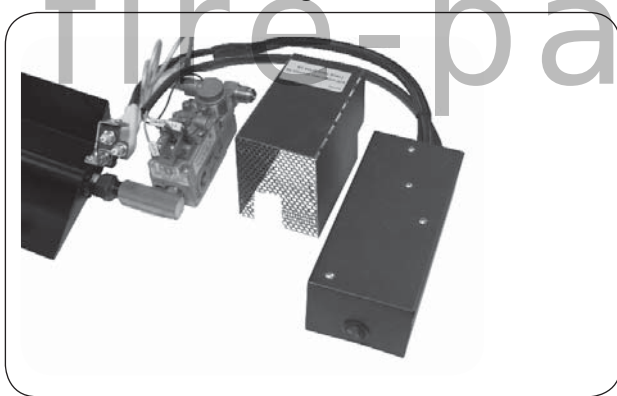

- 1. ALLUMAGE** - vérifiez le commutateur (marqué **I = mettez à feu** ; **O = au loin**) situé sur l'avant de la boîte de commutateur est placé aux minutes de l'attente cinq d'O. (5) pour que le gaz se dégage dehors.



- 1.** Serrez "**O**" (= "off") quand l'arrêt complet est désiré.



- 2.** Pression "**I**" (= "mettez à feu") après qu'une série d'étincelles rapides que le pilote s'allumera. Quand le pilote est stable, le brûleur principal mettra à feu.

- Attendez cinq (5) minutes pour dégager dehors n'importe quel gaz. Si vous sentez alors le gaz, **ARRÊTEZ !** Suivez l'information de sûreté ci-dessus. Si vous ne sentez pas le gaz, passez à la prochaine étape.
- Diminuez le "**I**" ; (**METTEZ À FEU**) branchez l'avant de la boîte de commutateur. Ceci transmet une série rapide d'étincelles à la tête pilote. Ces étincelles cessent quand la flamme pilote est allumée et écurie. Le pilote est situé au bon coin arrière du brûleur. Après une brève durée, le pilote allumera le brûleur principal.

ATTENTION: SI L'ENSEMBLE DE GAZ NE MET PAS À FEU DANS 20 SECONDES, ARRÊTEZ, TOURNEZ LE COMMUTATEUR À "OFF", ATTENDENT 5 MINUTES RÉPÉTENT ALORS DES ÉTAPES 3-6.

- **Le pilote devrait rester s'est allumé. S'il sort, répétez l'étape 3 à 6.**
- **Si le pilote ne restera pas allumé après que plusieurs essais, tournent la boîte de commutateur au "O" ; (AU LOIN) (fig. 20-1) et appelez votre fournisseur de technicien ou de gaz de service.**

- Pour arrêter l'ensemble, pressez le "**O**" ; (AU LOIN) branchez l'avant de la boîte de commutateur. L'écoulement de gaz cessera, et toutes les flammes sortiront.

Si cette unité était embarquée avec un extérieur, ou si un système à distance était installé plus tard, lisez et suivez les instructions à distance séparées d'actionner le brûleur à distance.

OUR ARRÊTER LE BRÛLEUR

- 1. Mettez le commutateur dans la position de repos. Le brûleur s'éteindra et le pilote sortira.**

LIGHTING INSTRUCTIONS - SERIES 01 VALVE

FOR YOUR SAFETY, READ BEFORE LIGHTING

WARNING: If you do not follow these instructions exactly, a fire or explosion may result, causing property damage, personal injury, or loss of life.

BEFORE LIGHTING, smell all around the gas burner area for gas. Be sure to smell next to the floor, because some gas is heavier than air and will settle on the floor. IF YOU SMELL GAS, FOLLOW THE INSTRUCTIONS ON P. 1.

1. **STOP!** Read the safety information above.
2. Turn off any electrical appliance used with the burner system.

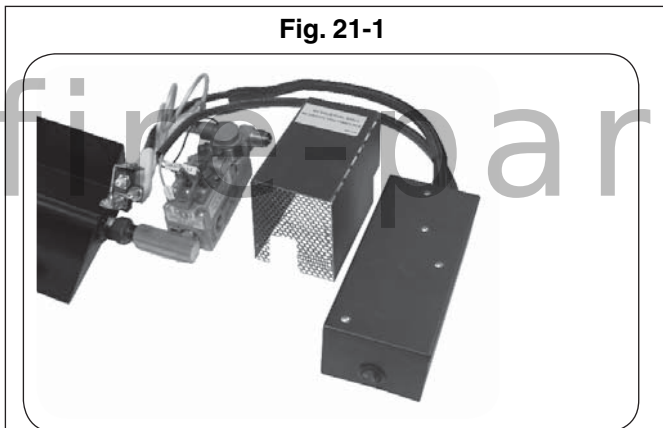

1. **LIGHTING** - Verify the switch (marked **I = IGNITE; O = OFF**) located on front of the switch box is set to **O**. Wait five (5) minutes for the gas to clear out.



1. Press **O (OFF)** when complete shutdown is desired.



2. Press **I (IGNITE)**
After a series of rapid sparks, the pilot will light. When the pilot is stable, the main burner will ignite.

3. Verify the switch (marked **I = IGNITE; O = OFF**) located on the front of the switch box is set to **"O" (OFF)**. Do not force.
4. Wait five (5) minutes to clear out any gas. If you then smell gas, **STOP!** Follow the safety information above. If you don't smell gas, go to the next step.
5. Depress the **"I" (IGNITE)** switch on the front of the switch box. This transmits a rapid series of sparks at the pilot head. These sparks cease when the pilot flame is lit and stable. The pilot is located at the rear right corner of the burner.

After a short time, the pilot will light the main burner.

CAUTION: IF THE GAS SET DOES NOT IGNITE WITHIN 20 SECONDS, STOP, PRESS **"O" (OFF)**, WAIT FIVE (5) MINUTES, THEN REPEAT STEPS 3-6.

- The pilot should remain lit. If it goes out, repeat steps 3 through 6.
- If the pilot will not stay lit after several tries, turn the switch box to **"O" (OFF)** (Fig. 21-1) and call your service technician or gas supplier.

6. To turn the set **OFF**, press the **"O" (OFF)** switch on the front of the switch box. The gas flow will cease, and all flames will go out.

If this unit was shipped with a remote, or if a remote system was installed later, read and follow the separate remote instructions to operate the burner remotely.

SHUT-OFF INSTRUCTIONS - SERIES 01 VALVE

1. Put the switch in the **OFF** position. The burner will extinguish, and the pilot will go out.

INSTRUCTIONS D'ÉCLAIRAGE - VALVE DE LA SÉRIE 11

POUR VOTRE SÛRETÉ, LISEZ AVANT DE S'ALLUMER

AVERTISSEMENT : Si vous ne suivez pas ces instructions exactement, un incendie ou une explosion peut résulter entraînant des dégâts matériels, des blessures ou la perte de la vie.

N'employez pas cet appareil si n'importe quelle partie a été sous-marine. Réclamez immédiatement un technicien de service professionnel qualifié et pour inspecter l'appareil et pour remplacer n'importe quelle partie du système de commande et de n'importe quelle commande de gaz qui a été sous l'eau.

Le Vrai-Fyre système de brûleur a un pilote qui peut être allumé à la main en utilisant une allumette ou un allumeur. En allumant le pilote, suivez ces instructions exactement.

AVANT DE S'ALLUMER, sentez tous autour du secteur de brûleur pour le gaz. Soyez sûr de sentir à côté du plancher car un certain gaz est plus lourd que l'air et arrangeriez sur le plancher. SI VOUS SENTEZ LE GAZ, SUIVEZ LES INSTRUCTIONS À LA P. 1.

Utilisez seulement votre main pour enfoncer ou pour tourner le bouton de commande de gaz. N'utilisez jamais les outils. Si le bouton n'enfoncera pas ou ne tournera pas à la main, n'essayez pas de le réparer. Appelez un technicien de service professionnel qualifié et. La force ou la réparation essayée peut avoir comme conséquence l'incendie ou l'explosion.

ALLUMANT LE PILOTE

Pour lire le bouton de commande de soupape de sûreté (Fig. 22-1) lisez l'indicateur formé par larme la plus proche en métal d'inscription.

1. Si le bouton de commande de soupape de sûreté est en position **PILOT**, enfoncez légèrement sur le bouton et tournez-le dans le sens des aiguilles d'une montre jusqu'à la position de **OFF**.
2. Libérez le bouton et attendez cinq minutes.
3. Tournez le bouton de soupape de sûreté dans le sens contraire des aiguilles d'une montre à la position **PILOT** (seulement le gaz pilote coulera quand le bouton est enfoncé).
4. Placez une longue allumette ou un allumeur de butane au brûleur pilote et en même temps, poussez le bouton de soupape de sûreté entièrement dedans. Le pilote s'allumera.
5. Tenez le bouton de soupape de sûreté dedans pendant approximativement 60 secondes avant de libérer.
6. Si le pilote ne reste pas s'allumait, la position de **OFF** de bouton de soupape de sûreté dans le sens des aiguilles d'une montre entièrement. Attendez cinq minutes, puis répétez les étapes 3. à 5.

METTANT À FEU LE BRÛLEUR PRINCIPAL

Avec lampe témoin, tournez le bouton de soupape de sûreté dans le sens contraire des aiguilles d'une montre à la position de **ON**. Commutez la commande d'interrupteur à levier à la position de **ON** et le brûleur s'allumera.

COUPANT LE BRÛLEUR PRINCIPAL

Commutez la commande d'interrupteur à levier à la position de **OFF**. Le pilote restera s'est allumé.

COUPANT LE PILOTE

Soyez sûr que commande d'interrupteur à levier est éteint et enfonce et tourne le bouton de soupape de sûreté dans le sens des aiguilles d'une montre à la position de **OFF**.

AJUSTANT LE PILOTE

1. La flamme pilote devrait encercler le bout de générateur, et est préréglée à l'usine (Fig. 22-2).
2. Si l'ajustement est nécessaire, (Fig. 22-1) tournez la vis d'approche de gaz dans le sens contraire des aiguilles d'une montre pour augmenter la flamme pilote, ou pour diminuer dans le sens des aiguilles d'une montre la flamme pilote.

ENTRETIEN

Votre brûleur à casserole est équipé d'un pilote de sûreté qui coupera l'offre de gaz au cas où le pilote serait ne brûlant pas ou ne fonctionnant pas correctement. Assurez-vous que le pilote est ajusté correctement et que les agrafes de cosse de générateur sont étroitement reliées aux vis terminales sur la valve. Si le pilote ne restera pas allumait, appelle votre utilité de gaz ou fournisseur locale de gaz.

Un contrôle périodique du suivant devrait être exécuté au moins annuellement par un représentant qualifié de service professionnel.

1. Valves et commande d'interrupteur à levier pour l'opération appropriée.
2. Système de conduite de cheminée pour la rouille, les dommages ou les fuites.
3. Une opération plus humide.
4. Orifices pour la saleté ou d'autres corps étrangers.
5. Contrôle visuel sur le brûleur.

Si cette unité était embarquée avec un extérieur, ou si un système à distance était installé plus tard, lisez et suivez les instructions à distance séparées d'actionner le brûleur à distance.

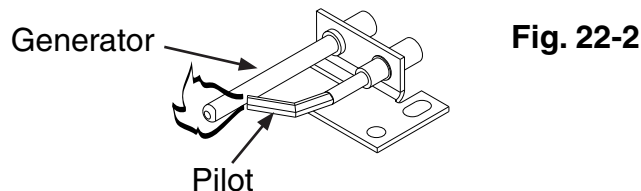
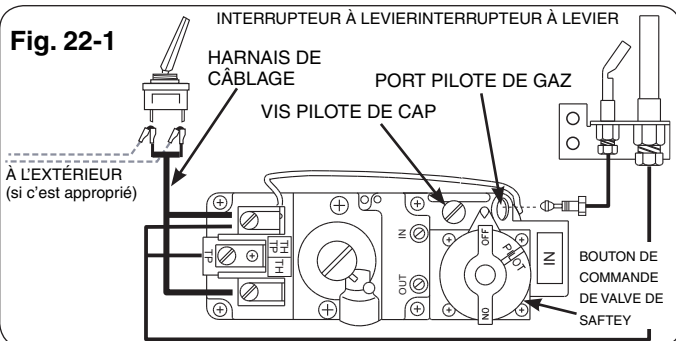

Note: La flamme pilote devrait encercler le dessus du générateur

LIGHTING INSTRUCTIONS - SERIES 11 VALVE

FOR YOUR SAFETY, READ BEFORE LIGHTING

WARNING

If you do not follow these instructions exactly, a fire or explosion may result, causing property damage, personal injury, or loss of life.

Do not use this appliance if any part has been underwater. Immediately call for a qualified professional service technician to inspect the appliance and to replace any part of the control system and any gas control that has been underwater.

The Real-Fyre® burner system has a pilot that can be lit by hand using a match or lighter. When lighting the pilot, follow these instructions exactly.

BEFORE LIGHTING, smell all around the burner area for gas. Be sure to smell next to the floor, as some gas is heavier than air and will settle on the floor. IF YOU SMELL GAS, FOLLOW THE INSTRUCTIONS ON P. 1.

Use only your hand to push in or turn the gas control knob. Never use tools. If the knob will not push in or turn by hand, don't try to repair it. Call a qualified professional service technician. Force or attempted repair may result in fire or explosion.

LIGHTING THE PILOT

To read the safety valve control knob (Fig. 23-1), read the marking nearest the teardrop-shaped metal pointer.

1. If the safety valve control knob is in the **PILOT** position, push in slightly on the knob and rotate it clockwise ↻ to the **OFF** position.
2. Release knob and wait five (5) minutes.
3. Turn safety valve knob counterclockwise ↺ to the **PILOT** position. (Only the pilot gas will flow when the knob is pushed in.)
4. Place a long match or a butane lighter at the pilot burner, and at the same time, push the safety valve knob fully in. The pilot will light.
5. Hold the safety valve knob in for approximately 60 seconds before releasing.
6. **If the pilot does not stay lit**, turn the safety valve knob clockwise ↻ to the full **OFF** position. Wait five (5) minutes, then repeat steps 3 through 5.

IGNITING THE MAIN BURNER

With the pilot lit, turn the safety valve knob counterclockwise ↺ to the **ON** position. Switch the toggle switch control to the **ON** position, and the burner will light. Refer to the PARTS LIST for the toggle switch location.

SHUTTING OFF THE MAIN BURNER

Switch the toggle switch control to the **OFF** position. The pilot will remain lit.

SHUTTING OFF THE PILOT

Be sure the toggle switch control is **OFF** and depress and turn the safety valve knob clockwise ↻ to the **OFF** position.

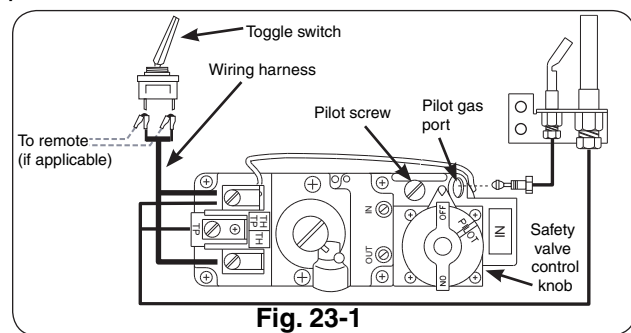

Fig. 23-1

ADJUSTING THE PILOT

- a. The pilot flame should encircle the generator tip, and is preset at the factory (Fig. 23-2).
- b. If adjustment is necessary (Fig. 23-1), turn the gas adjustment screw counterclockwise ↺ to increase the pilot flame, or clockwise ↻ to decrease the pilot flame.

MAINTENANCE

Your pan burner is equipped with a safety pilot that will shut off the gas supply in the event that the pilot is not functioning properly. Make sure the pilot is adjusted properly and that the generator spade clips are tightly connected to the terminal screws on the valve. If the pilot will not stay lit, call your local gas utility or gas supplier.

A periodic check of the following should be performed at least annually by a qualified professional service representative:

1. Valves and toggle switch control for proper operation.
2. Flue system for rust, damage, or leaks.
3. Damper operation.
4. Orifices for dirt or other foreign matter.
5. Visual check on the burner.

If this unit was shipped with a remote, or if a remote system was installed later, read and follow the separate remote instructions to operate the burner remotely.

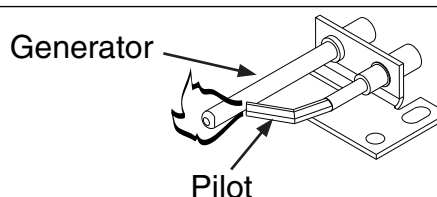

Note: Pilot flame should encircle top of the generator.

Fig. 23-2 Lighting the pilot

fire-parts.com

Please use this page to record any information about your unit that you may want to have at hand.

PILOT BURNER ADJUSTMENT

The pilot burner is preset at the factory and should normally not require any adjustment. However, should adjustment be necessary, the following steps should be taken:

With the pilot burner lit and the control knob in the pilot position, remove the heatshield covers. Adjust the screw located on the control valve (see Fig. 25-1). Using a screwdriver, turn the pilot adjustment screw slowly clockwise to reduce the

flame, or counterclockwise to increase the flame. The adjustment screw can be turned so that the pilot flame is completely extinguished. The pilot flame should be a quiet soft blue flame with yellow tipping that encircles the thermocouple tip.

Replace the heatshield covers. Turn the control knob to the **ON** position to assure proper ignition of the log set.

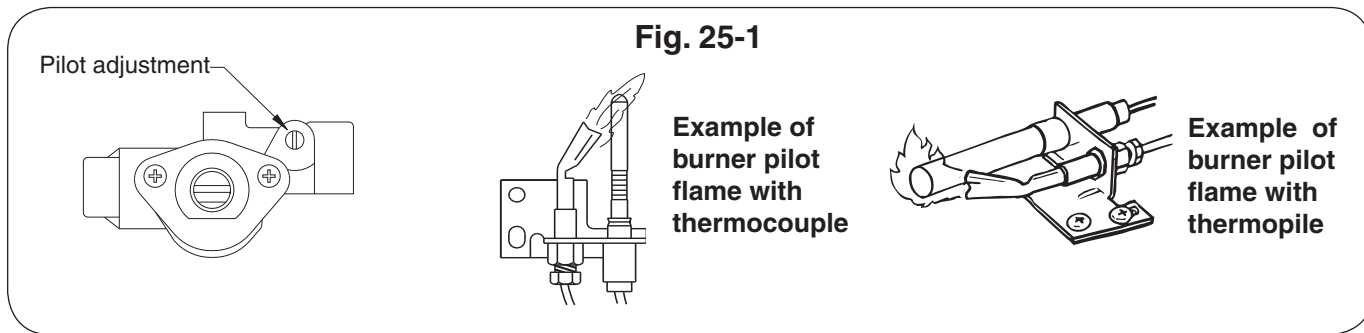

fire-parts.com

TROUBLESHOOTING

POSSIBLE CAUSE	SOLUTIONS
1 BURNER SHUTTING DOWN DURING OPERATION	
A. Insufficient or excessive gas pressure	A1. Check gas pressure (Read G.- I. of IMPORTANT PRE-INSTALLATION AND FIREPLACE SAFETY INFORMATION section, & check with local gas company). A2. Other gas appliances may be on the same gas line, dropping gas pressure to log set. Check pressures with everything operating to ensure adequate pressure.
B. Log placement	B. Reference the LOG PLACEMENT section in this manual for recommended log positioning.
C. Flue area, fireplace, or damper dirty from soot	C. Clean around, above, and under damper thoroughly. Clean fireplace, removing loose material, including soot and creosote.
D. Fireplace too small for unit	D. Ensure minimum requirements are met. (See FIREPLACE SIZE REQUIREMENT section in this owner's manual.)
E. Pilot flame lifting off thermocouple/generator	E. Check gas pressure (see section A1).
F. Pilot (remote compatible)	F. Contact your dealer for instructions on replacement.
2 PILOT WILL NOT LIGHT	
A. Pilot flame lifting off thermocouple/generator	A. Check gas pressure (see Section 1, A1 of this table).
B. Electronic spark not lighting pilot	B. Check to assure sparking when activated. Note: You may need to turn or press ignitor several times to ignite pilot. See LIGHTING INSTRUCTIONS for your control valve.
C. Ignitor electrode wire loose	C. Check wiring and reconnect any loose wiring.
D. Gas supply off/manual shutoff valve closed	D. Turn on gas supply or open manual shutoff valve.
E. Air in gas line	E. Bleed the gas supply line and repeat LIGHTING INSTRUCTIONS until air is removed.
F. Pilot hood blocked	F. Check for debris or dirt / Clean pilot
G. Dead batteries (electronic pilots only)	G. Replace batteries as needed.
3 LOW FLAME HEIGHT	
A. Gas pressure	A. Check gas pressure (see Section 1, A1 of this table).
B. Propane tank running low	B. Fill tank completely.
4 BURNER NOT BURNING EVENLY	
A. Burner orifice clogged	A. Clean burner orifice.
5 ODORS	
A. Gas leak	A. Shut off gas, if possible. Follow instructions on front page. Have a qualified professional installer or the gas company correct all leaks.
B. New home, new carpet, or new paint	B. When these odors are drawn into the fireplace, this may cause objectionable odors. Thoroughly ventilate the area before restarting your log set.

TROUBLESHOOTING (Cont.)

POSSIBLE CAUSE	SOLUTIONS
6 SOOTING	
A. On logs, in firebox, or room	A. Check gas pressure (see Section 1, A1 of this table).
B. Drafts in room	B. Eliminate drafts by closing heating and air conditioning vents, returns, and outside air vents. Fans blowing directly into fireplace should be turned off when set is operating.
C. Air shutters blocked (if applicable)	C. Air shutters are blocked with debris. Vacuum debris away from air shutter.
D. Log placement	D. See solution in Section 1, B.
E. Using natural-gas burner on propane gas or propane burner on natural gas	E. If the gas listed on the nameplate does not match the gas you are burning, shut down the burner system immediately and completely (including pilot) following the steps in the LIGHTING INSTRUCTIONS section. Then call your dealer.
F. Adding any accessories to log sets	F. Shut down log set and take off any logs or accessories that do not belong with the set.

7 PILOT WILL NOT STAY LIT	
A. Valve won't hold	A. Contact your dealer for instructions on replacement.
B. Pilot hood not aimed at thermocouple	B. Pilot hood bent; replace pilot or angle pilot hood properly so pilot flame hits thermocouple.
C. Pilot line bent	C. Replace pilot line.
D. Thermocouple is loose	D. Tighten thermocouple nut at gas control valve.
E. Thermocouple cracked or worn out	E. Replace thermocouple.
F. Excessive down draft	F. Install chimney cap / Outside chimney too close to other peaks / Check chimney flue for proper height / Poorly designed chimney

FLAME DESCRIPTION

Observe the flames. The main burner flames should be blue at the base and a combination of blue/yellow at the body and at the tips. They should be 5" (127mm) to 8" (203mm) above the logs, with the center flame being the tallest (see cover photo). The ember flames should be 1/4" (6mm) above the embers.

WARRANTY

PETERSON VENTED DECORATIVE GAS APPLIANCE LIMITED WARRANTY

All Peterson gas logs are **WARRANTED for as long as you own them (lifetime)**.

All Peterson burner assemblies are **WARRANTED for TEN (10) YEARS**.

All Peterson glass is **WARRANTED for FIVE (5) YEARS**.

SPK-26 controls are covered by a **THREE (3) YEAR "All Parts" Warranty**.

APK-17 controls are covered by a **TWO (2) YEAR "All Parts" Warranty**.

All other Peterson valves, pilots, and controls are covered by a **ONE (1) YEAR Limited Warranty (excluding batteries)**.

PLEASE KEEP A COPY OF YOUR SALES SLIP FOR PROOF OF PURCHASE

This warranty applies to the original purchaser and to single family residential use only. It commences from date of purchase, and is valid only with proof of purchase.

This warranty does not cover parts becoming defective through misuse, accidental damage, electrical damage, improper handling, lack of routine maintenance, storage, and/or installation. Product must be installed (and gas must be connected) as specified in the instructions or operator's manual, by a **qualified professional installer**. Accessories, parts, valves, remotes, etc., when used must be Peterson Co. product.

This warranty **does not** apply to rust, corrosion, oxidation, or discoloration, unless the affected component becomes inoperable. It **does not** cover labor or labor-related charges.

This warranty specifically excludes liability for **indirect, incidental, or consequential damages**. Some states do not allow the exclusion or limitation of incidental or consequential damages, so the above exclusion may not apply to you. This warranty gives you specified legal rights, and you may have other rights that may vary from state to state.

For additional information regarding this warranty, or to place a warranty claim, contact the R.H. Peterson dealer where the product was purchased.

**TO REGISTER YOUR PRODUCT ONLINE GO TO: WWW.RHPETERSON.COM,
AND CLICK ON PRODUCT REGISTRATION. THANK YOU FOR YOUR PURCHASE.**

fire-parts.com

FOR USE IN THE COMMONWEALTH OF MASSACHUSETTS

INSTALLATION OF THIS APPLIANCE MUST BE PERFORMED BY A MASSACHUSETTS

LICENSED PLUMBER OR GAS FITTER ONLY.

**CONNECTOR KITS USED FOR INSTALLATION AND OPERATION OF THIS APPLIANCE MUST
NOT BE MORE THAN 36" IN LENGTH.**

**FIREPLACE DAMPER MUST BE REMOVED OR PERMANENTLY
FIXED/WELDED IN FULL OPEN POSITION PRIOR TO
INSTALLING THIS PRODUCT.**

Quality Check			Date: _____		
Burner Orifices	Nat.	L.P.	Leak Test: _____	Model#:	_____
Main:	_____	_____	Burn Test: _____	Serial#:	_____
Other:	_____	_____	Gas Type: <u>Nat.</u> / <u>L.P.</u>	Air Shutter:	_____
				Inspector:	_____