

SUBMITTAL SHEET



AIRCONDITIONING PRODUCTS

SYSTEM INDOOR/OUTDOOR

12RS11 RS1211/C1211

CEILING RECESSED AIR CONDITIONER

SS12RS11-1

GENERAL DATA		(AT 115V)			
POWER V/PH/Hz		115/1/60			
Circuit Ampacity, Min. (A)	(A)	15			
Fuse size, Max. (A)	(A)	15			
COMPRESSOR					
		Rotary-Hermetic			
No. used		1			
R.L. Amps - L.R. Amps (A)		9.8-60			
Crankcase Heater		-			
OUTDOOR FAN - TYPE					
		Propeller			
Dia. (in.) - No. used		15-3/4 - 1			
Type Drive - No. speeds		Direct - 1			
No. Poles - RPM (High)		6 - 820			
No. Motors - HP		1 - 1/38			
CFM (High)		820			
F.L. Amps. (A)		0.7			
OUTDOOR COIL - TYPE					
		Aluminum Fin & Copper Pipe			
Fin Type - Pipe Type		Slit Plate - Inner Riffled			
Rows - F.P.I.		2 - 15.9			
Face Area (sq.ft.)		3.46			
Tube Size (in.)		3/8			
INDOOR FAN - TYPE					
		Centrifugal			
Dia. & Length (in.) - No. used		7 & 9-1			
No. speeds		3 & Auto			
No. Poles -RPM (High)		6-1,030			
No. Motors - HP		1 - 1/25			
CFM (HI/MED/LOW)		280/245/220			
F.L. Amps (A)		0.7			
INDOOR COIL - TYPE					
		Aluminum Fin & Copper Pipe			
Fin Type - Pipe type		Slit Plate - Inner Riffled			
Rows - F.P.I.		3 - 14.1			
Face Area (sq. ft.)		1.29			
Tube Size (in.)		3/8			
Drain Connection Size (in.)		1-1/32			
REFRIGERANT					
		R22			
Lbs. - R22 (O.D. Unit)		2.66			
Control		Capillary Tube			
Connection		Flare			
Line Length, Max (ft.)		65			
Lift difference, Max (ft.)		23			
Line Size - in. O.D. Discharge		1/4			
Line Size - in. O.D. Suction		1/2			
DIMENSIONS (in.)					
	H	x	W	x	D
Indoor Unit	-Uncrated	12-5/8	x	31-29/32	x 24-13/32
	-Crated	17-23/32	x	36-7/32	x 31-1/2
Outdoor Unit	-Uncrated	20-7/8	x	29-17/32	x 11-1/32
	-Crated	23-17/32	x	35-13/32	x 13-7/8
WEIGHT					
		INDOOR	OUTDOOR		
Net (lbs.)		68.0	90.4		
Shipping (lbs.)		99.0	97.0		
Shipping Volume(cu.ft.)					
		11.7	6.7		

PERFORMANCE DATA @ ARI STANDARD CONDITIONS (115V)

COOLING		
Total Capacity (BTU/H)		11,500
Sensible Capacity (BTU/H)		7,340
Latent Capacity (BTU/H)		4,160
SEER		10.0
Dehumidification (Pints/H)		3.1
Amps (A)		11.2
Power Inputs (W)		1,200
Outdoor Sound Rating (bels)		7.0

FEATURE

Controls	Microprocessor
Remote Controller	LCD Wireless type
Temperature Control	IC Thermostat
Timer	ON/OFF, 24 hours
Night Setback	Built-in
Air Louver (Horizontal)	-
(Vertical)	Manual
Power Failure Automatic Restart	Built-in
Self Diagnosis	N/A

OPTION

Refrigerant Line Set	AP1205BH (15 ft)
	AP1207BH (20 ft)
	AP1210BH (30 ft)
Low Ambient Control	N/A
Fresh Air Intake	Available
Central Remote ON-OFF Control	Available
Air duct Extension	N/A
Indoor Frame Extension	N/A
Condensate Drain Pump	Available
Non-Removable Remo-con Bracket	Available

OPERATING RANGE

Cooling	Indoor	Outdoor
	Intake Air	Intake Air
Maximum	95 F DB/71 F WB	115 F DB
Minimum	67 F DB/57 F WB	67 F DB

CERTIFICATION



12RS11

SUBMITTAL SHEET



AIRCONDITIONING PRODUCTS

SYSTEM INDOOR/OUTDOOR

12RLS11 RS1211/CL1211

CEILING RECESSED LOW AMBIENT AIR CONDITIONER

S12RLS11-1

GENERAL DATA		(AT 115V)				
POWER V/PH/HZ						
Circuit Ampacity, Min. (A)		15				
Fuse size, Max. (A)		15				
COMPRESSOR						
		Rotary-Hermetic				
No. used		1				
R.L. Amps - L.R. Amps (A)		9.8-60				
Crankcase Heater		20W				
OUTDOOR FAN - TYPE						
		Propeller				
Dia. (in.) - No. used		15-3/4 - 1				
Type Drive - No. speeds		Direct - 1				
No. Poles - RPM (High)		6 - 820				
No. Motors - HP		1 - 1/38				
CFM (High)		820				
F.L. Amps. (A)		0.7				
OUTDOOR COIL - TYPE						
		Aluminum Fin & Copper Pipe				
Fin Type - Pipe Type		Slit Plate - Inner Riffled				
Rows - F.P.I.		2 - 15.9				
Face Area (sq.ft.)		3.46				
Tube Size (in.)		3/8				
INDOOR FAN - TYPE						
		Centrifugal				
Dia. & Length (in.) - No. used		7 & 9-1				
No. speeds		3 & Auto				
No. Poles -RPM (High)		6-1,030				
No. Motors - HP		1 - 1/25				
CFM (HI/MED/LOW)		280/245/220				
F.L. Amps (A)		0.7				
INDOOR COIL - TYPE						
		Aluminum Fin & Copper Pipe				
Fin Type - Pipe type		Slit Plate - Inner Riffled				
Rows - F.P.I.		3 - 14.1				
Face Area (sq. ft.)		1.29				
Tube Size (in.)		3/8				
Drain Connection Size (in.)		1-1/32				
REFRIGERANT						
		R22				
Lbs. - R22 (O.D. Unit)		2.66				
Control		Capillary Tube				
Connection		Flare				
Line Length, Max (ft.)		65				
Lift difference, Max (ft.)		23				
Line Size - in. O.D. Discharge		1/4				
Line Size - in. O.D. Suction		1/2				
DIMENSIONS (in.)						
	H	x	W	x	D	
Indoor Unit	-Uncrated	12-5/8	x	31-29/32	x	24-13/32
	-Crated	17-23/32	x	36-7/32	x	31-1/2
Outdoor Unit	-Uncrated	20-7/8	x	29-17/32	x	11-1/32
	-Crated	23-17/32	x	35-13/32	x	13-7/8
WEIGHT						
	INDOOR		OUTDOOR			
Net (lbs.)	68.0		92.0			
Shipping (lbs.)	99.0		99.0			
Shipping Volume(cu.ft.)						
	11.7		6.7			

PERFORMANCE DATA @ ARI STANDARD CONDITIONS (115V)

COOLING		
Total Capacity (BTU/H)		11,500
Sensible Capacity (BTU/H)		7,340
Latent Capacity (BTU/H)		4,160
SEER		10.0
Dehumidification (Pints/H)		3.1
Amps (A)		11.2
Power Inputs (W)		1,200
Outdoor Sound Rating (bels)		7.0

FEATURE

Controls	Microprocessor
Remote Controller	LCD Wireless type
Temperature Control	IC Thermostat
Timer	ON/OFF, 24 hours
Night Setback	Built-In
Air Louver (Horizontal)	-
(Vertical)	Manual
Power Failure Automatic Restart	Built-In
Self Diagnosis	N/A

OPTION

Refrigerant Line Set	AP1205BH (15 ft)
	AP1207BH (20 ft)
	AP1210BH (30 ft)
Low Ambient Control	Built-In
Fresh Air Intake	Available
Central Remote ON-OFF Control	Available
Air duct Extension	N/A
Indoor Frame Extension	N/A
Condensate Drain Pump	Available
Non-Removable Remo-con Bracket	Available

OPERATING RANGE

Cooling	Indoor Air Intake Temp.		Outdoor Air Intake Temp.	
	Maximum	Minimum	Maximum	Minimum
	95 F DB/71 F WB	67 F DB/57 F WB	115 F DB	0 F DB

CERTIFICATION



12RLS11

DIMENSIONAL DATA

Indoor Unit: RS1211

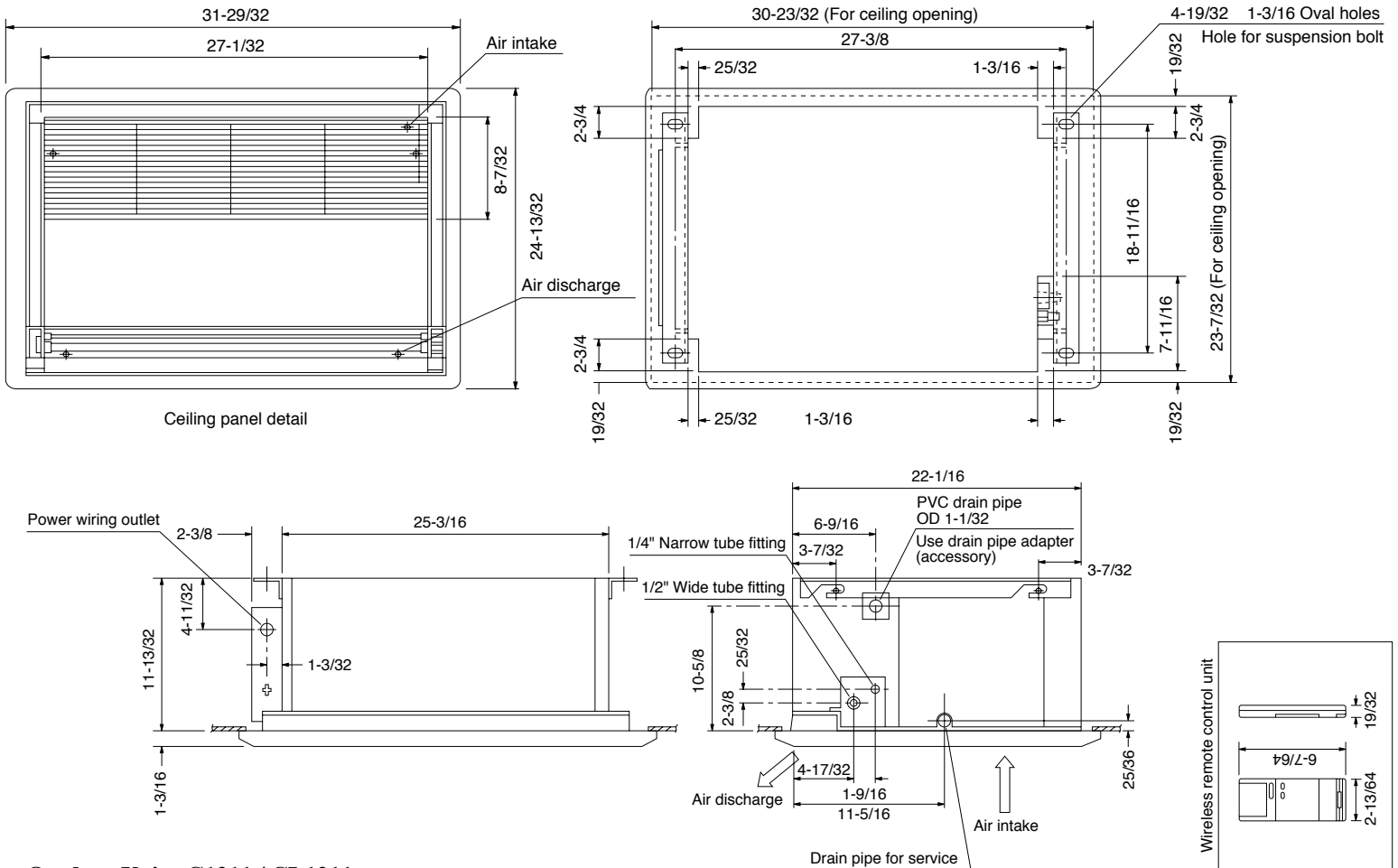

Outdoor Unit: C1211 / CL1211

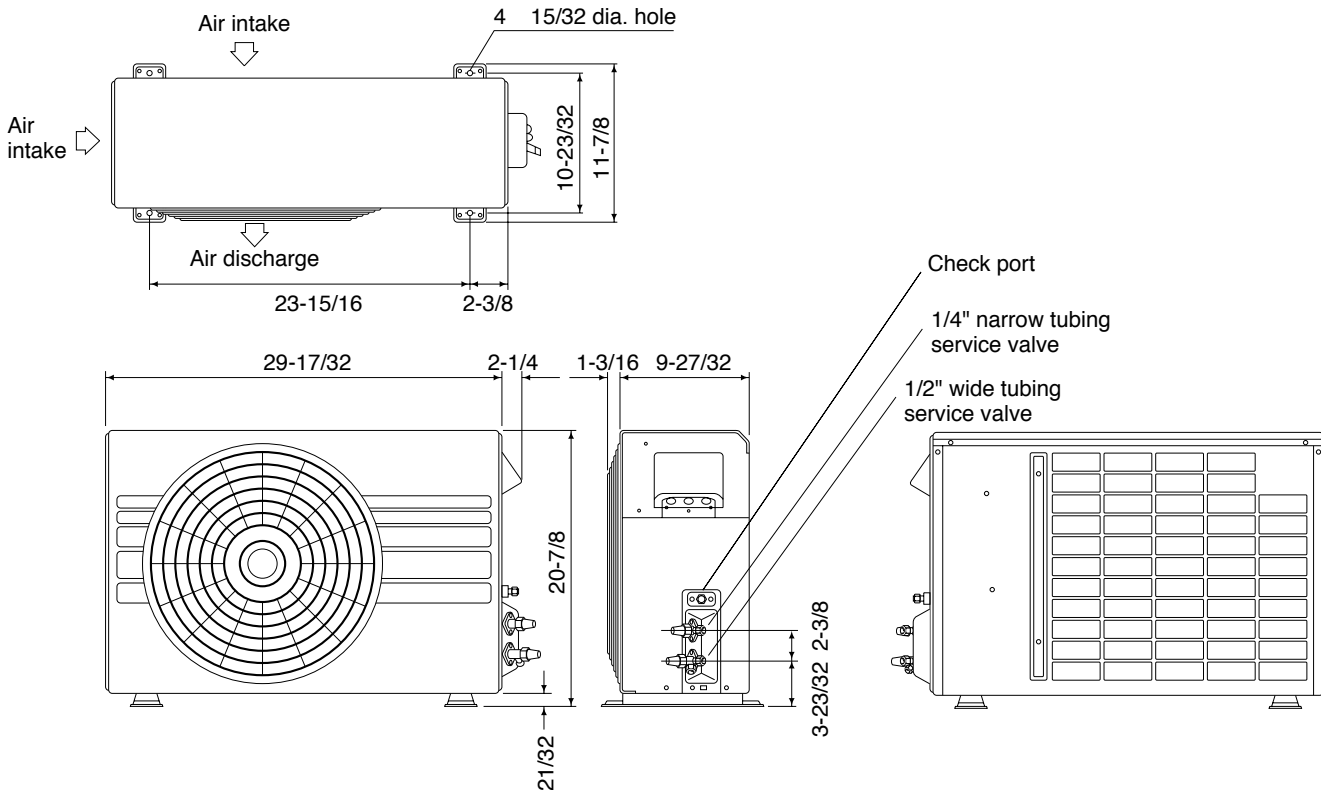

WARRANTY

SANYO products are warranted against defects in materials and workmanship for the period below;

	LABOR	PARTS
Compressor	30 Days	5 Years
Other Components	N/A	1 Year

Full specific warranty rights, conditions, exclusions and obligations are specified in the warranty packed with each products.

Because of a policy of continuous product improvements, SANYO reserves the right to change specifications and design without notice.

SANYO FISHER COMPANY
A Division of SANYO North America Corporation
21605 Plummer St. Chatsworth, CA 91311
Phone : (818) 998-7322
Fax : (818) 701-4160
Website: <http://www.sanyohvac.com>