

# SERVICE MANUAL

## **Series PEA** **Ceiling Concealed**

Model name

<Indoor unit>

**PEA-RP200GAQ**

**PEA-RP250GAQ**

**PEA-RP400GAQ**

**PEA-RP500GAQ**

• This manual describes only service data of the indoor units.

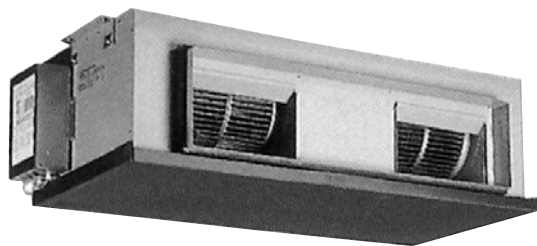

Indoor unit



Remote controller (option)

## CONTENTS

1. TYPES OF INDOOR UNITS.....	2
2. SAFETY PRECAUTION .....	3
3. PART NAMES AND FUNCTIONS.....	8
4. SPECIFICATIONS .....	10
5. DATA .....	11
6. OUTLINES AND DIMENSIONS .....	13
7. WIRING DIAGRAM .....	16
8. REFRIGERANT SYSTEM DIAGRAM .....	20
9. TROUBLESHOOTING .....	21
10. SERVICE DATA (PARTS NAME) .....	33

**1****TYPES OF INDOOR UNITS**

Specification Model name	Service Reference
PEA-RP200GAQ	PEA-RP200GAQ(R2).TH-AF
PEA-RP250GAQ	PEA-RP250GAQ(R2).TH-AF
PEA-RP400GAQ	PEA-RP400GAQ(R1).TH-AF
PEA-RP500GAQ	PEA-RP500GAQ(R1).TH-AF

## CAUTIONS RELATED TO NEW REFRIGERANT

## Cautions for units utilising refrigerant R410A

**Use new refrigerant pipes.**

In case of using the existing pipes for R22, be careful with the followings.

- Be sure to perform replacement operation before test run.
- Avoid using thin pipes.

**Make sure that the inside and outside of refrigerant piping is clean and it has no contamination such as sulfur hazardous for use, oxides, dirt, shaving particles, etc. In addition, use pipes with specified thickness.**

Contamination inside refrigerant piping can cause deterioration of refrigerant oil etc.

**Store the piping to be used during installation indoors and keep both ends of the piping sealed until just before brazing. (Leave elbow joints, etc. in their packaging.)**

If dirt, dust or moisture enter into refrigerant cycle, that can cause deterioration of refrigerant oil or malfunction of compressor.

**Use ester oil, ether oil or alkylbenzene oil (small amount) as the refrigerant oil applied to flares and flange connections.**

If large amount of mineral oil enter, that can cause deterioration of refrigerant oil etc.

**Charge refrigerant from liquid phase of gas cylinder.**

If the refrigerant is charged from gas phase, composition change may occur in refrigerant and the efficiency will be lowered.

**Do not use refrigerant other than R410A.**

If other refrigerant (R22 etc.) is used, chlorine in refrigerant can cause deterioration of refrigerant oil etc.

**Use a vacuum pump with a reverse flow check valve.**

Vacuum pump oil may flow back into refrigerant cycle and that can cause deterioration of refrigerant oil etc.

**Use the following tools specifically designed for use with R410A refrigerant.**

The following tools are necessary to use R410A refrigerant.

Tools for R410A	
Gauge manifold	Flare tool
Charge hose	Size adjustment gauge
Gas leak detector	Vacuum pump adaptor
Torque wrench	Electronic refrigerant charging scale

**Keep the tools with care.**

If dirt, dust or moisture enter into refrigerant cycle, that can cause deterioration of refrigerant oil or malfunction of compressor.

**Do not use a charging cylinder.**

If a charging cylinder is used, the composition of refrigerant will change and the efficiency will be lowered.

**Ventilate the room if refrigerant leaks during operation. If refrigerant comes into contact with a flame, poisonous gases will be released.**

**[1] Cautions for service**

- (1) Perform service after collecting the refrigerant left in unit completely.
- (2) Do not release refrigerant in the air.
- (3) After completing service, charge the cycle with specified amount of refrigerant.
- (4) When performing service, install a filter drier simultaneously.  
Be sure to use a filter drier for new refrigerant.

## [2] Storage of Piping Material

### (1) Storage location



Store the pipes to be used indoors. (Warehouse at site or owner's warehouse)  
Storing them outdoors may cause dirt, waste, or water to infiltrate.

### (2) Pipe sealing before storage

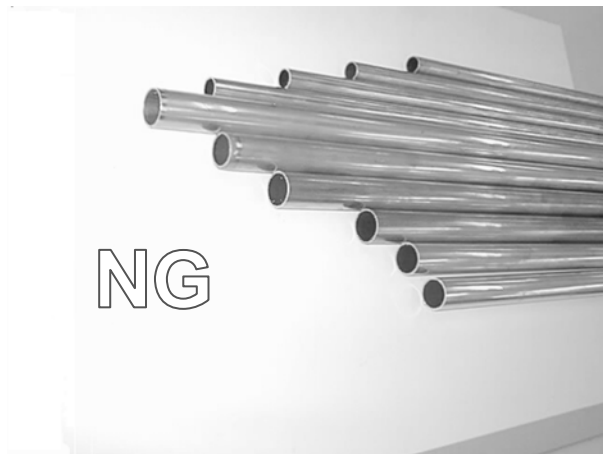
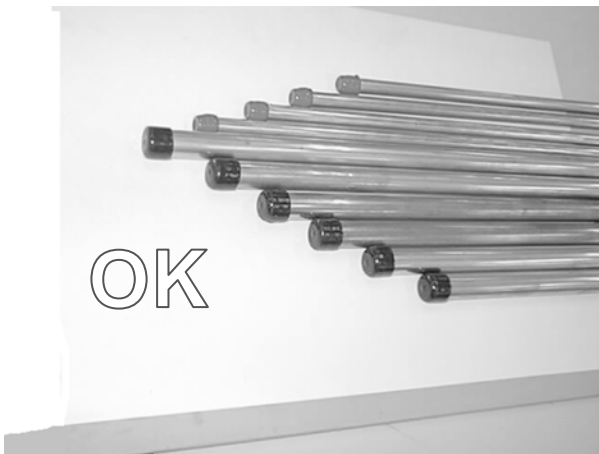

Both ends of the pipes should be sealed until immediately before brazing.  
Wrap elbows and T's in plastic bags for storage.

\* The new refrigerant oil is 10 times more hygroscopic than the conventional refrigerant oil (such as Suniso). Water infiltration in the refrigerant circuit may deteriorate the oil or cause a compressor failure. Piping materials must be stored with more care than with the conventional refrigerant pipes.

### [3] Brazing

No changes from the conventional method, but special care is required so that foreign matter (ie. oxide scale, water, dirt, etc.) does not enter the refrigerant circuit.

Example: Inner state of brazed section

When non-oxide brazing was not used

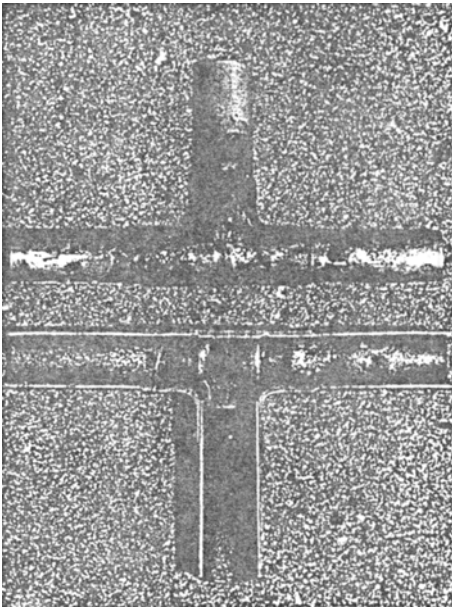

When non-oxide brazing was used

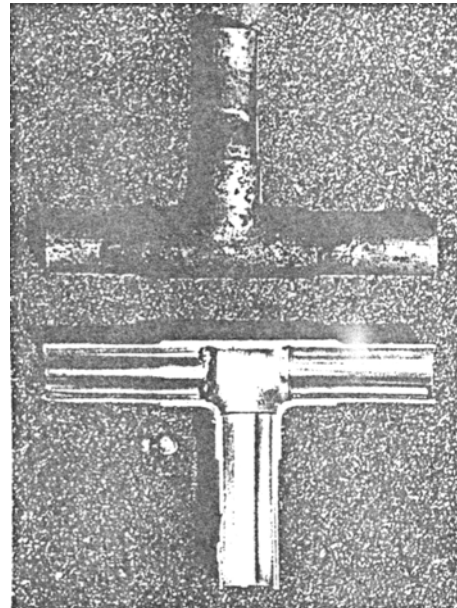

#### Items to be strictly observed:

1. Do not conduct refrigerant piping work outdoors on a rainy day.
2. Apply non-oxide brazing.
3. Use a brazing material (BCuP-3) which requires no flux when brazing between copper pipes or between a copper pipe and copper coupling.
4. If installed refrigerant pipes are not immediately connected to the equipment, then braze and seal both ends of them.

#### Reasons:

1. The new refrigerant oil is 10 times more hygroscopic than the conventional oil. The probability of a machine failure if water infiltrates is higher than with conventional refrigerant oil.
2. A flux generally contains chlorine. A residual flux in the refrigerant circuit may generate sludge.

#### Note:

- Commercially available antioxidants may have adverse effects on the equipment due to its residue, etc. When applying non-oxide brazing, use nitrogen.

## [4] Airtightness Test

No changes from the conventional method. Note that a refrigerant leakage detector for R22 cannot detect R407C leakage.

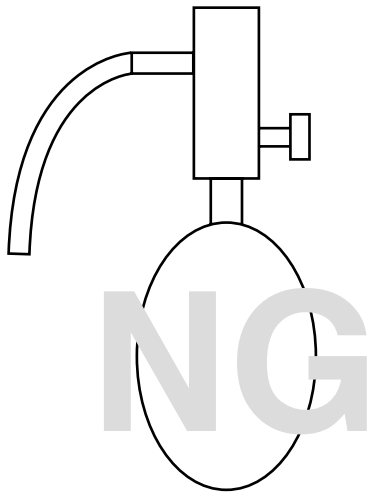

Halide torch

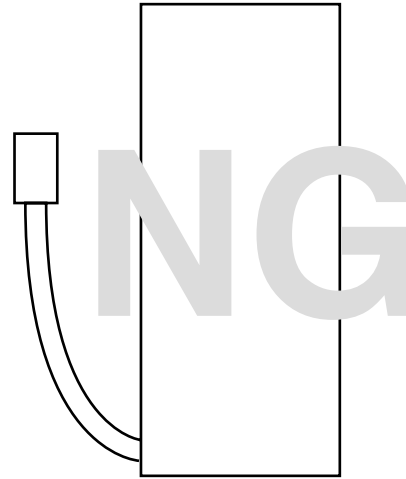

R22 leakage detector

### Items to be strictly observed:

1. Pressurize the equipment with nitrogen up to the design pressure and then judge the equipment's airtightness, taking temperature variations into account.
2. When investigating leakage locations using a refrigerant, be sure to use R407C.
3. Ensure that R407C is in a liquid state when charging.

### Reasons:

1. Use of oxygen as the pressurized gas may cause an explosion.
2. Charging with R407C gas will lead the composition of the remaining refrigerant in the cylinder to change and this refrigerant can then not be used.

### Note:

- A leakage detector for R407C is sold commercially and it should be purchased.

## [5] Vacuuming

1. Vacuum pump with check valve

A vacuum pump with a check valve is required to prevent the vacuum pump oil from flowing back into the refrigerant circuit when the vacuum pump power is turned off (power failure).

It is also possible to attach a check valve to the actual vacuum pump afterwards.

2. Standard degree of vacuum for the vacuum pump

Use a pump which reaches 0.5 Torr (500 MICRON) or below after 5 minutes of operation.

In addition, be sure to use a vacuum pump that has been properly maintained and oiled using the specified oil. If the vacuum pump is not properly maintained, the degree of vacuum may be too low.

3. Required accuracy of the vacuum gauge

Use a vacuum gauge that can measure up to 5 Torr. Do not use a general gauge manifold since it cannot measure a vacuum of 5 Torr.

4. Evacuating time

- Evacuate the equipment for 1 hour after  $-755$  mmHg (5 Torr) has been reached.
- After evacuating, leave the equipment for 1 hour and make sure that vacuum is not lost.

5. Operating procedure when the vacuum pump is stopped

In order to prevent a backflow of the vacuum pump oil, open the relief valve on the vacuum pump side or loosen the charge hose to draw in air before stopping operation.

The same operating procedure should be used when using a vacuum pump with a check valve.

## [6] Additional refrigerant charge

### When charging directly from cylinder

- Check that cylinder for R410A on the market is syphon type.
- Charging should be performed with the cylinder of syphon stood vertically. (Refrigerant is charged from liquid phase.)

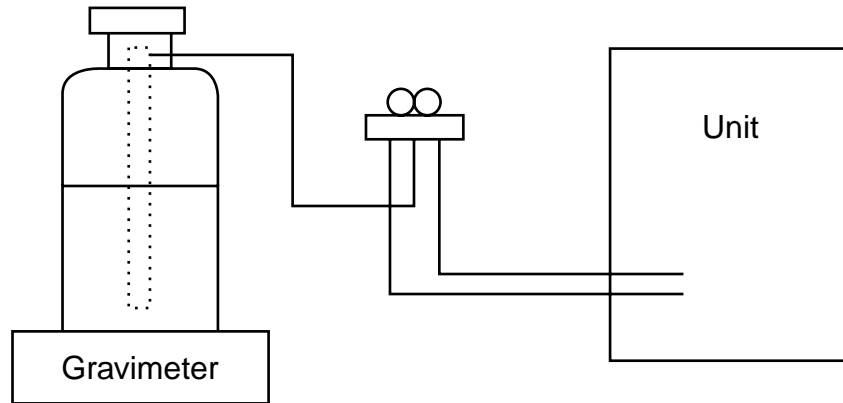

## [7] Service tools

Use the below service tools as exclusive tools for R410A refrigerant.

No.		Specifications
①	Gauge manifold	·Only for R410A
		·Use the existing fitting specifications. (UNF1/2)
		·Use high-tension side pressure of 5.3MPa-G or over.
②	Charge hose	·Only for R410A
		·Use pressure performance of 5.09MPa-G or over.
③	Electronic scale	—
④	Gas leak detector	·Use the detector for R134a, R407C or R410A.
⑤	Adaptor for reverse flow check	·Attach on vacuum pump.
⑥	Refrigerant charge base	—
⑦	Refrigerant cylinder	·Only for R410A
		Top of cylinder (Pink) Cylinder with syphon
⑧	Refrigerant recovery equipment	—

# 3

# PART NAMES AND FUNCTIONS

## ● Indoor Unit

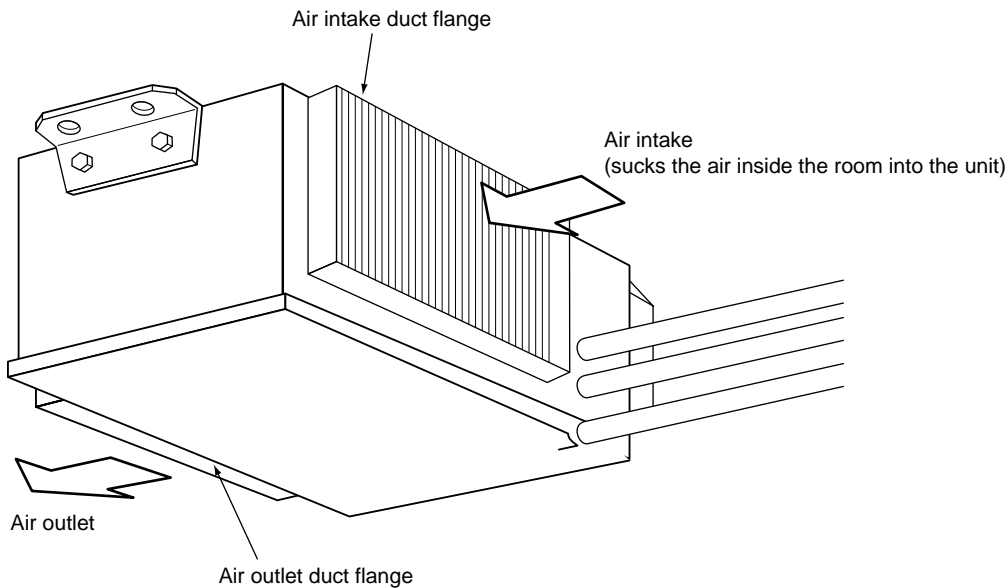

## ● Remote controller (option)

Once the controls are set, the same operation mode can be repeated by simply pressing the ON/OFF button.

## ● Operation buttons

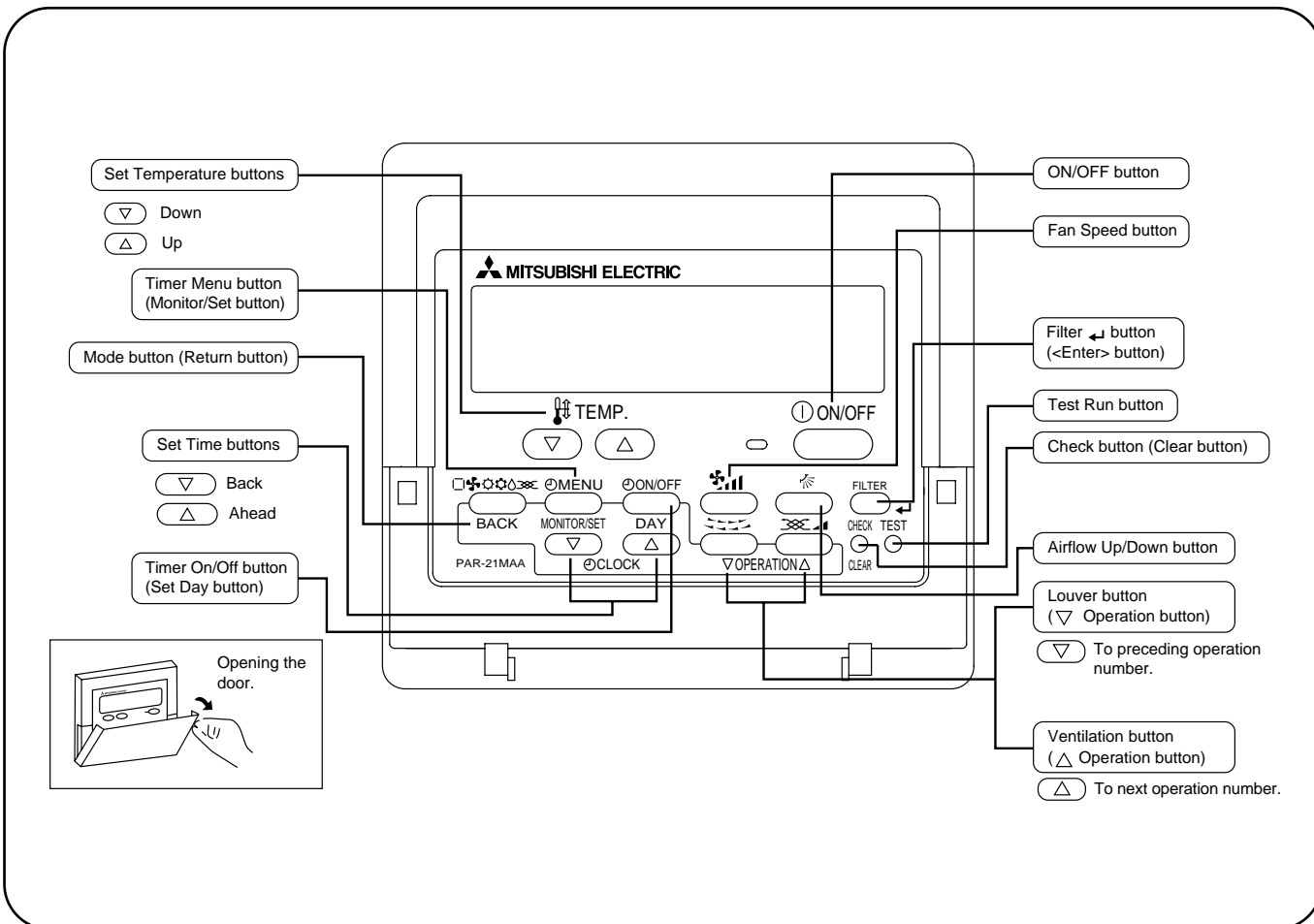



## ● Display

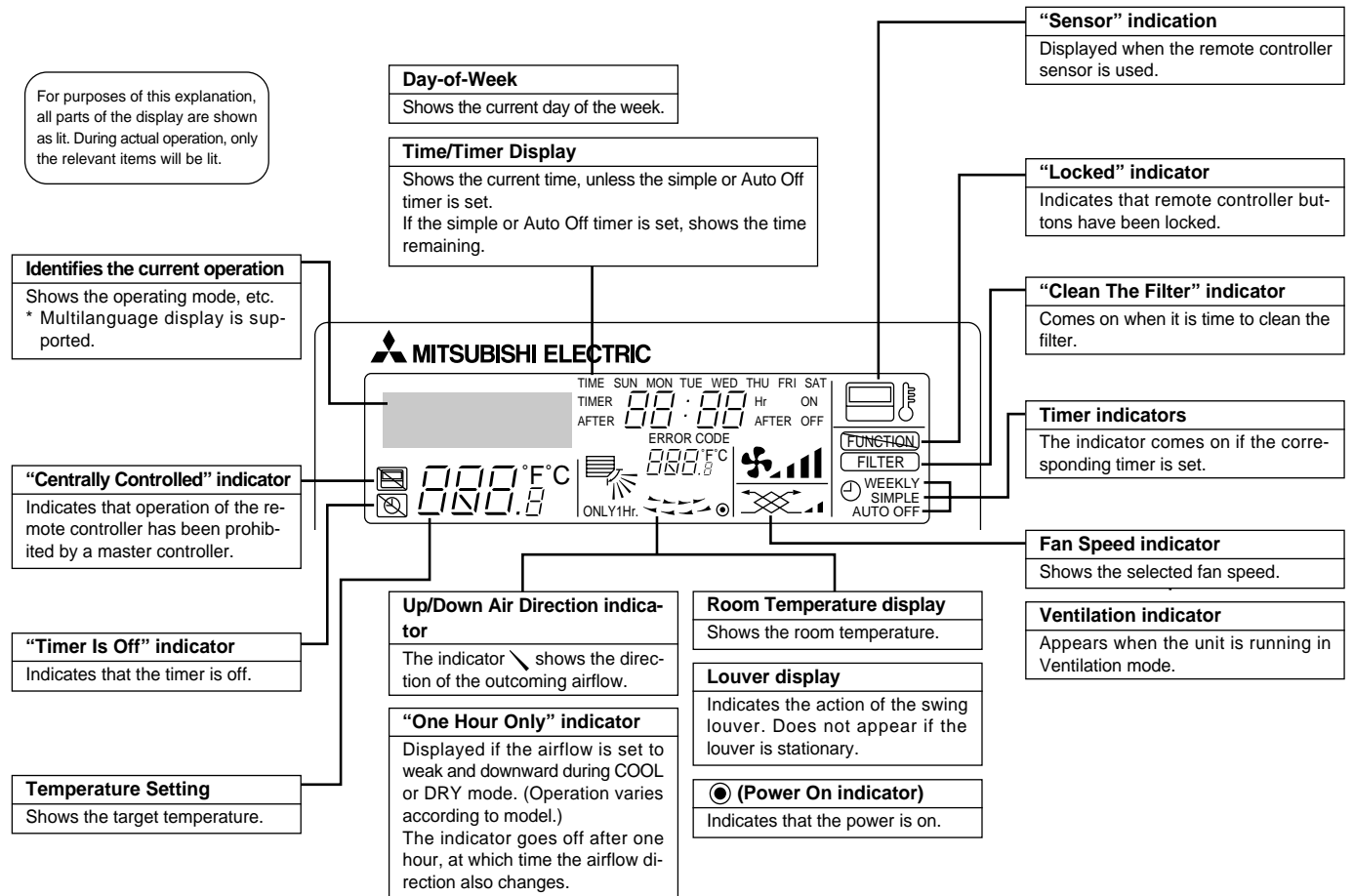

### Caution

- Only the Power on indicator lights when the unit is stopped and power supplied to the unit.
- If you press a button for a feature that is not installed at the indoor unit, the remote controller will display the “Not Available” message.  
If you are using the remote controller to drive multiple indoor units, this message will appear only if the feature is not present at the parent unit.
- When power is turned ON for the first time, it is normal that “PLEASE WAIT” is displayed on the room temperature indication (For max. 2minutes). Please wait until this “PLEASE WAIT” indication disappears then start the operation.

## 4

## SPECIFICATIONS

Model name			PEA-RP200GAQ		PEA-RP250GAQ	
Mode			Cooling	Heating	Cooling	Heating
Power supply (phase, cycle, voltage)			3PH 4W 50Hz 380-415V		3PH 4W 50Hz 380-415V	
Input		kW	1.00	1.00	1.18	1.18
Running current		A	2.0	2.0	2.3	2.3
External finish			Galvanized steel		Galvanized steel	
Heat exchanger			Cross fin coil		Cross fin coil	
Fan (drive) × No.			Centrifugal (direct) ×2		Centrifugal (direct) ×2	
Fan motor output			0.77		0.77	
Fan	Airflow	Hi	CMM	65	80	
			L/s	1083	1333	
	Lo	CMM	52	64		
		L/s	867	1067		
External static pressure		Pa	150	150		
		mmAq	15	15		
Operation control & Thermostat			Remote control & built in		Remote control & built in	
Sound level		Hi	dB(A)		51	
		Lo	dB(A)		48	
					49	
Drain connection			R1		R1	
Dimensions		H	mm	400	400	
		W	mm	1400	1600	
		D	mm	634	634	
Weight			kg	70	77	
			lbs	154	169	

Model name			PEA-RP400GAQ		PEA-RP500GAQ	
Mode			Cooling	Heating	Cooling	Heating
Power supply (phase, cycle, voltage)			3PH 4W 50Hz 380-415V		3PH 4W 50Hz 380-415V	
Input		kW	1.55	1.55	2.84	2.84
Running current		A	3.8	3.8	5.4	5.4
External finish			Galvanized steel		Galvanized steel	
Heat exchanger			Cross fin coil		Cross fin coil	
Fan (drive) × No.			Centrifugal (direct) ×2		Centrifugal (direct) ×2	
Fan motor output			1.3		1.8	
Fan	Airflow	CMM	120		160	
			L/s		2,000	
	External static pressure	Pa	150		150	
		mmAq	15		15	
Operation control & Thermostat			Remote control & built in		Remote control & built in	
Sound level		dB(A)	52		53	
Drain connection			R1		R1	
Dimensions		H	mm	595	595	
		W	mm	1947	1947	
		D	mm	764	764	
Weight			kg	130	133	
			lbs	286	293	

### 5-1. Sound Data

Indoor units

PEA-RP200,250: Upper High/Lower Low

Model	SPL dB(A)	OCTAVE BAND FREQ.Hz							
		63Hz	125Hz	250Hz	500Hz	1000Hz	2000Hz	4000Hz	8000Hz
PEA-RP200GAQ	51	55	54	51	49	47	43	33	27
	48	50	50	47	46	44	40	29	21
PEA-RP250GAQ	52	56	55	52	50	48	44	34	28
	49	51	51	48	47	45	41	30	22
PEA-RP400GAQ	52	53	51	52	50	46	44	39	30
PEA-RP500GAQ	53	55	54	51	50	48	44	40	31

### Position measurement

Indoor unit

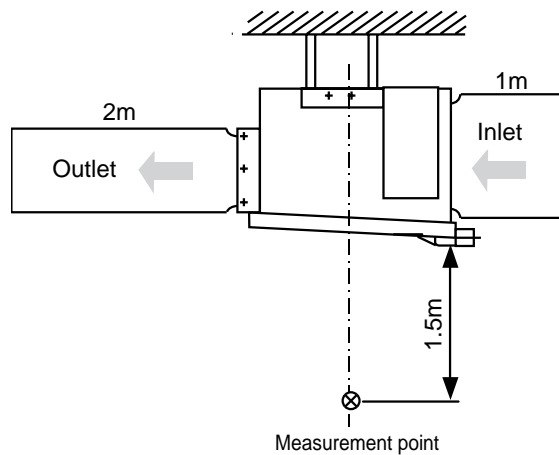

## 5-2. Fan Performance Curve

### Indoor units

**PEA-RP200GAQ**  
Fan Performance Curve 50Hz

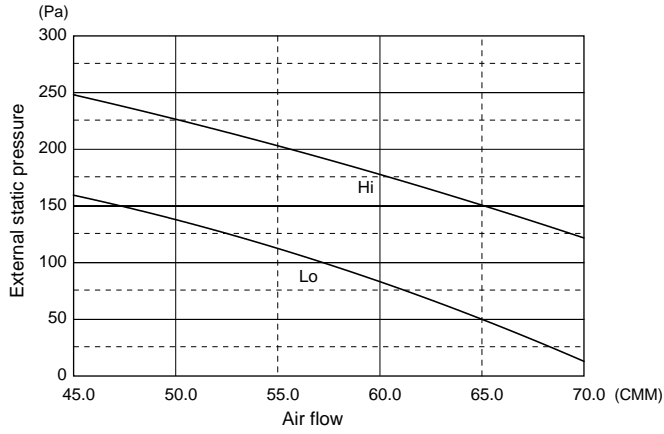

**PEA-RP250GAQ**  
Fan Performance Curve 50Hz

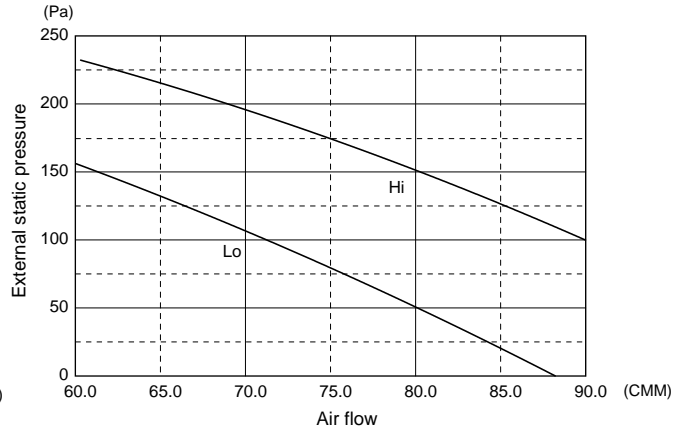

**PEA-RP400GAQ**  
Fan Performance Curve 50Hz

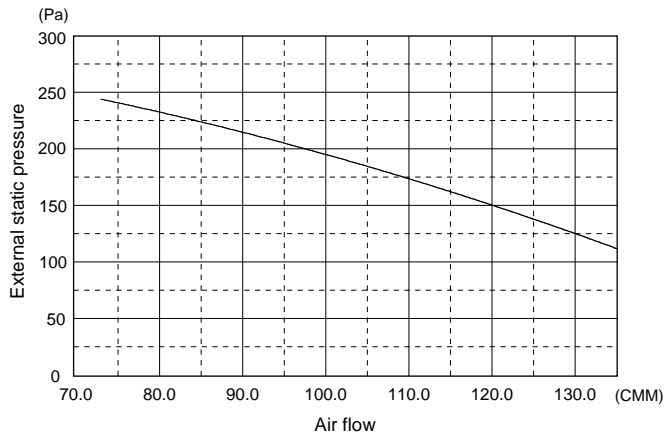

**PEA-RP500GAQ**  
Fan Performance Curve 50Hz

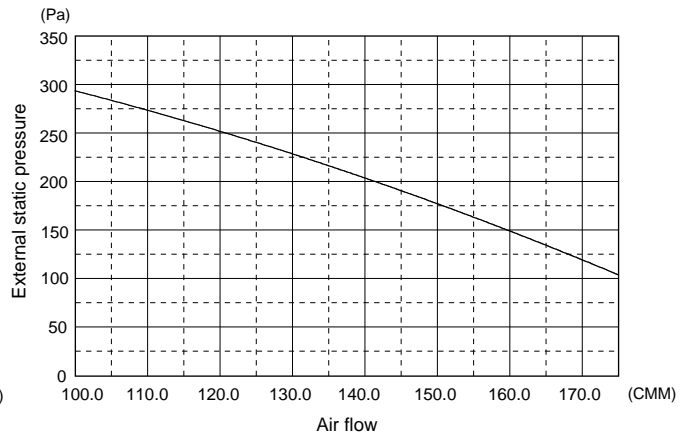

PEA-RP200GAQ

Unit : mm

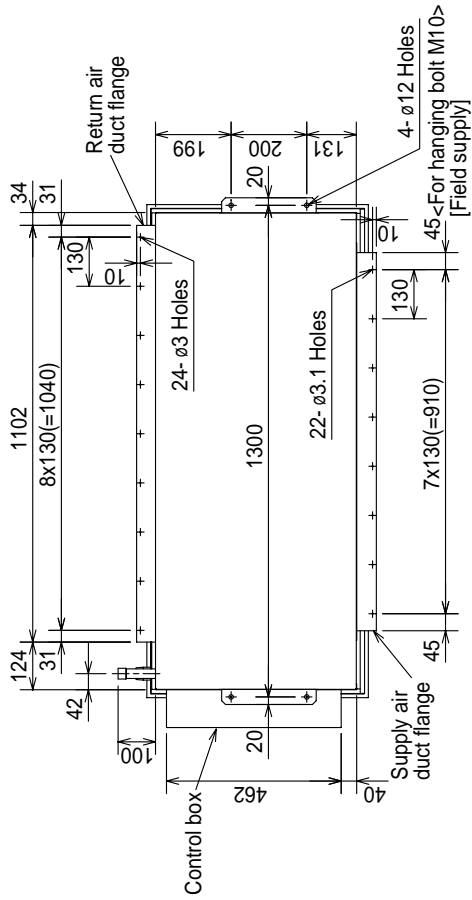

Top view

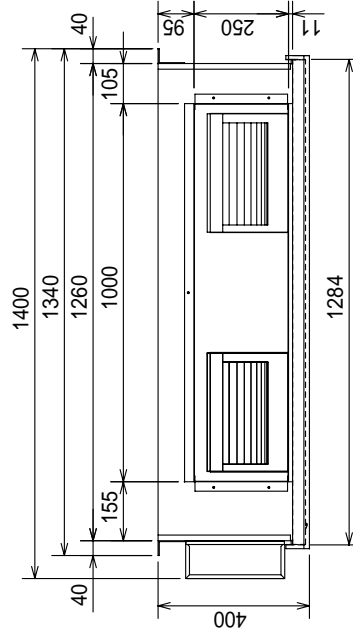

Front view

- <Accessory>
- Pipe cover ..... 2pcs.  
(For dew condensation prevention of local piping and unit connection.)
- Remote controller..... 1pc.

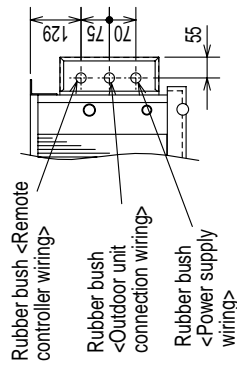

A

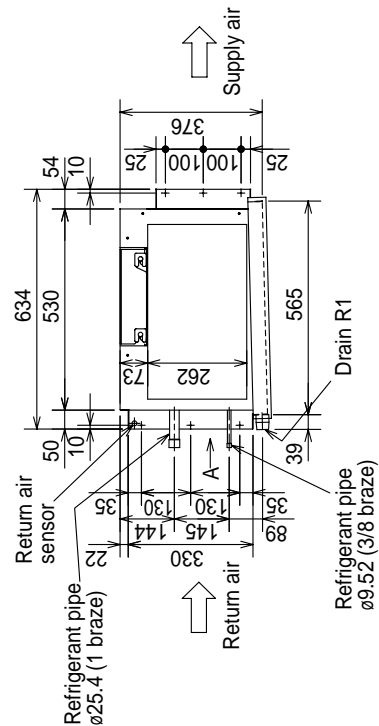

Left side view

PEA-RP250GAQ

Unit : mm

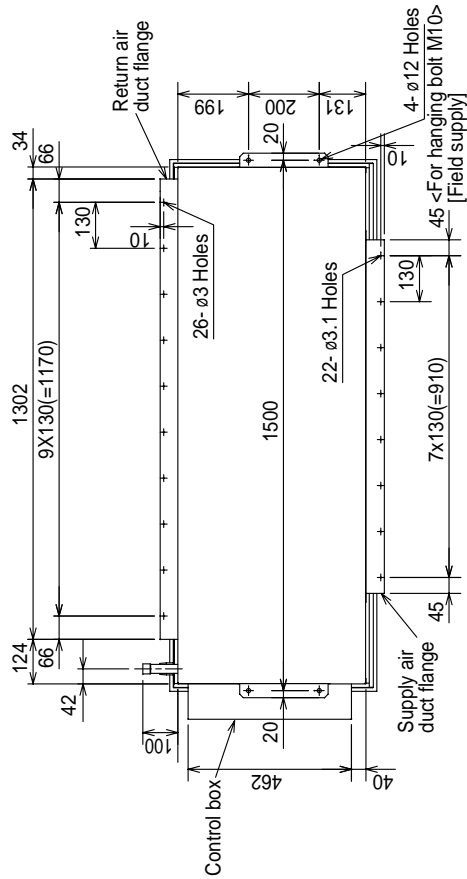

Top view

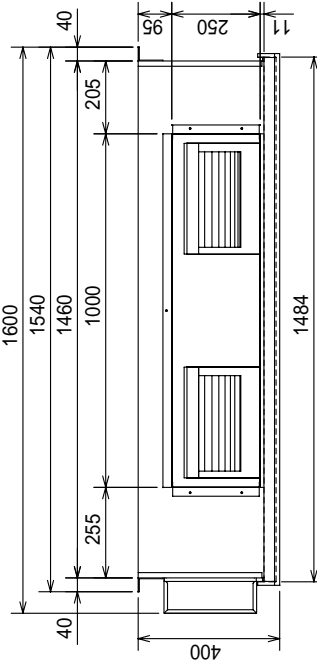

Front view

- <Accessory>
- Pipe cover ..... 2pcs.  
(For dew condensation prevention of local piping and unit connection.)
- Remote controller ..... 1pc.

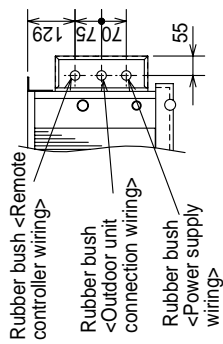

A

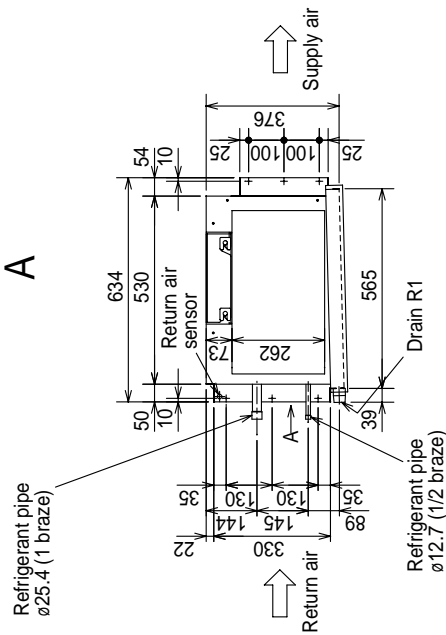

Left side view



PEA-RP200,250GAQ

SYMBOL	NAME
MF1	FAN MOTOR (INDOOR)
51F	OVER CURRENT RELAY (INDOOR FAN MOTOR)
52FL0	MAGNETIC CONTACTOR (INDOOR FAN MOTOR-LOW SPEED)
52FH	MAGNETIC CONTACTOR (INDOOR FAN MOTOR-HIGH SPEED)
49F	INTERNAL THERMOSTAT (INDOOR FAN MOTOR)
TB2.4.5	TERMINAL BLOCK
TH1	ROOM TEMP
TH2	THERMISTOR LIQUID PIPE TEMP
TH5	CONDIEVA TEMP
X1	AUXILIARY RELAY
CR1.2	SURGE KILLER
FB	FERRITE CORE
INDOOR CONTROLLER BOARD	
FLUSE	FUSE (T6.3A/250V)
ZNR	VARIATOR
X4-6	AUXILIARY RELAY
SW1	SWITCH (MODEL SELECTION)
SW2	SWITCH (CAPACITY CODE)
SWE	CONNECTOR (EMERGENCY OPERATION)
LED1	LED (POWER SUPPLY)
LED2	LED (POWER SUPPLY-REMOTE CONTROLLER)
LED3	LED (TRANSMISSION-INDOOR-OUTDOORS)
CN2L	CONNECTOR (LOSSNAV)
CN3	CONNECTOR (DRAIN SENSOR)
CN32	CONNECTOR (REMOTE SWITCH)
CN4	CONNECTOR (FA TERMINAL-A)
CN5	CONNECTOR (CENTRALLY CONTROL)
SNB BOARD 1	
ZNR5-7	VARIATOR ARRESTER
DSADR	ARRESTER
SYMBOL	NAME
TB6	TERMINAL BLOCK

- Notes:
1. Color of earth wire is yellow and green twisting.
  2. Specification subject to change without notice.
  3. Indoor and outdoor connecting wires are made with polarities, make sure matching wiring and terminal.
  4. Emergency operation  
If a trouble occurs with either the remote controller or the indoor microcomputer and no other trouble exists, emergency operation for cooling or heating can be performed by changing the setting of connector (SWE) "ON" on the indoor controller board.  
SWE : ON / Indoor fan is running high speed.
  5. Symbols used in wiring diagram above are:  
⊙: TERMINAL  
⊕: CONNECTOR  
--- (HEAVY DOTTED LINE): FIELD WIRING  
- - - (THIN DOTTED LINE): OPTIONAL PARTS  
6. (\*)SW2 shows PEA-RP250 setting.  
In case of PEA-RP200 setting is shown as below.



Caution,  
 1. To protect fan motor from abnormal current, over current relays is installed.  
 Therefore, do not change factory set value of over current relays.

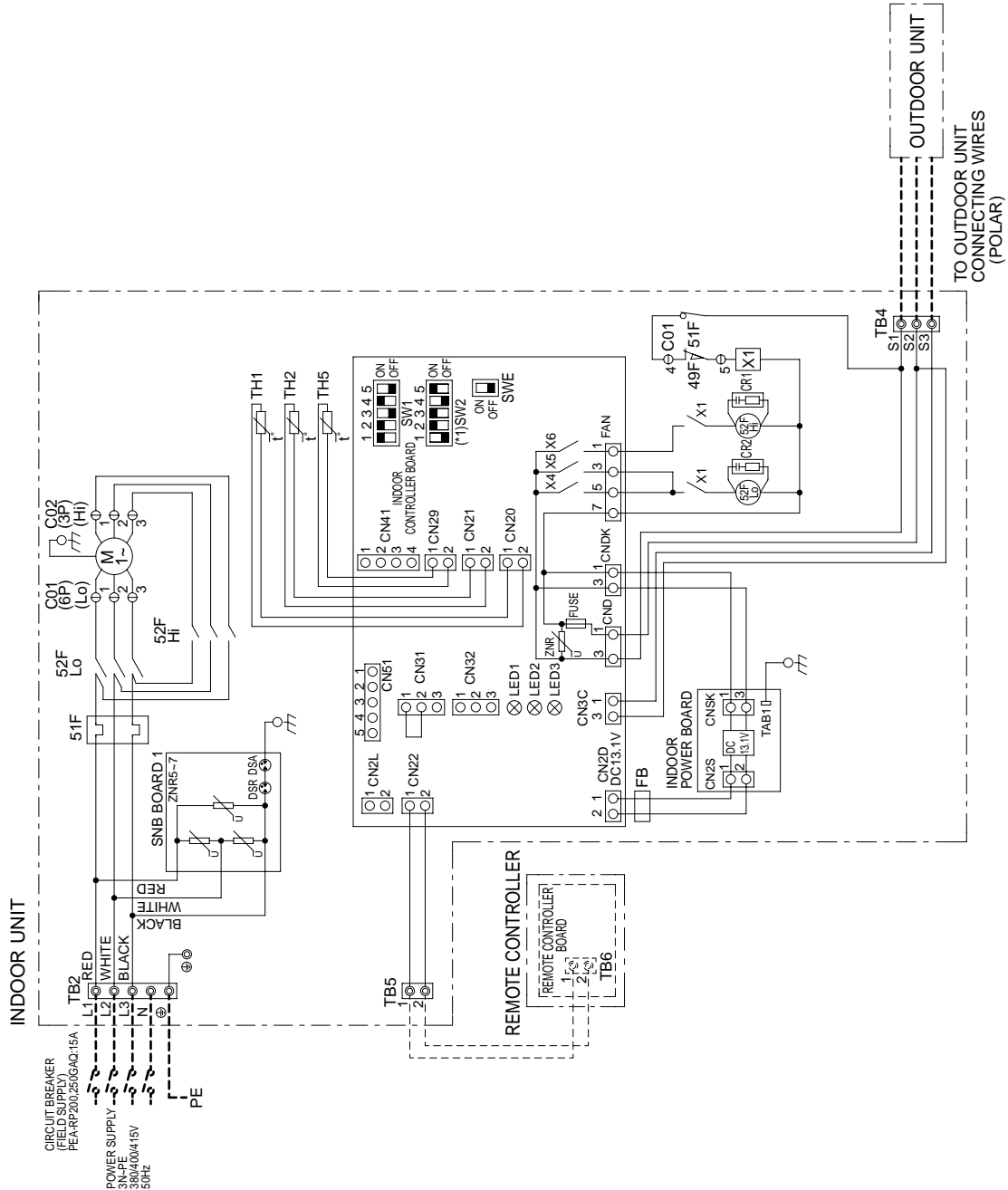



# PEA-RP200,250GAQR2

SYMBOL	NAME
MF1	FAN MOTOR (INDOOR)
51F	OVER CURRENT RELAY (INDOOR FAN MOTOR)
52FLo	MAGNETIC CONTACTOR (INDOOR FAN MOTOR<LOW SPEED>)
52FHi	MAGNETIC CONTACTOR (INDOOR FAN MOTOR<HIGH SPEED>)
49F	INTERNAL THERMOSTAT (INDOOR FAN MOTOR)
TB2,4,5	TERMINAL BLOCK
TH1	ROOM TEMP
TH2	THERMISTOR LIQUID PIPE TEMP
TH5	CONDIE/VA TEMP
X1	AUXILIARY RELAY
CR1,2	SURGE KILLER
FB	FERRITE CORE
INDOOR BOARD	
FUSE	FUSE (T6.3A/250V)
ZNR	VARIABLE
X4-6	AUXILIARY RELAY
SW1	SWITCH (MODEL SELECTION)
SW2	SWITCH (CAPACITY CODE)
SWE	CONNECTOR (EMERGENCY OPERATION)
LED1	LED (POWER SUPPLY)
LED2	LED (POWER SUPPLY<REMOTE CONTROLLER>)
LED3	LED (TRANSMISSION<INDOOR-OUTDOOR>)
CN2L	CONNECTOR (LOSS/NA)
CN3	CONNECTOR (DRAIN SENSOR)
CN32	CONNECTOR (REMOTE SWITCH)
CN41	CONNECTOR (HA TERMINAL-A)
CN61	CONNECTOR (CENTRALLY CONTROL)
SNB BOARD 1	
ZNRS-7	VARIABLE
DSA,DSR	ARRESTER

SYMBOL	NAME
TB6	TERMINAL BLOCK

- Note: 1. Color of earth wire is yellow and green twisting.  
 2. Specification subject to change without notice.  
 3. Indoor and outdoor connecting wires are made with polarities, make sure matching wiring and terminal.  
 4. Emergency operation  
 If a trouble occurs with either the remote controller or the indoor microcomputer and no other trouble exists, emergency operation for cooling or heating can be performed by changing the setting of connector (SWE) 'ON' on the indoor controller board.  
 SWE : ON / Indoor fan is running high speed.  
 ○:CONNECTOR  
 ⊙:TERMINAL  
 --- (HEAVY DOTTED LINE):FIELD WIRING  
 - - - (THIN DOTTED LINE):OPTIONAL PARTS  
 6. (\*)SW2 shows PEA-RP250 setting.  
 In case of PEA-RP200 setting is shown as below.

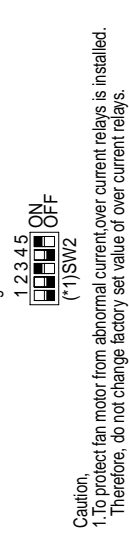

Caution.  
 1. To protect fan motor from abnormal current, over current relays is installed. Therefore, do not change factory set value of over current relays.

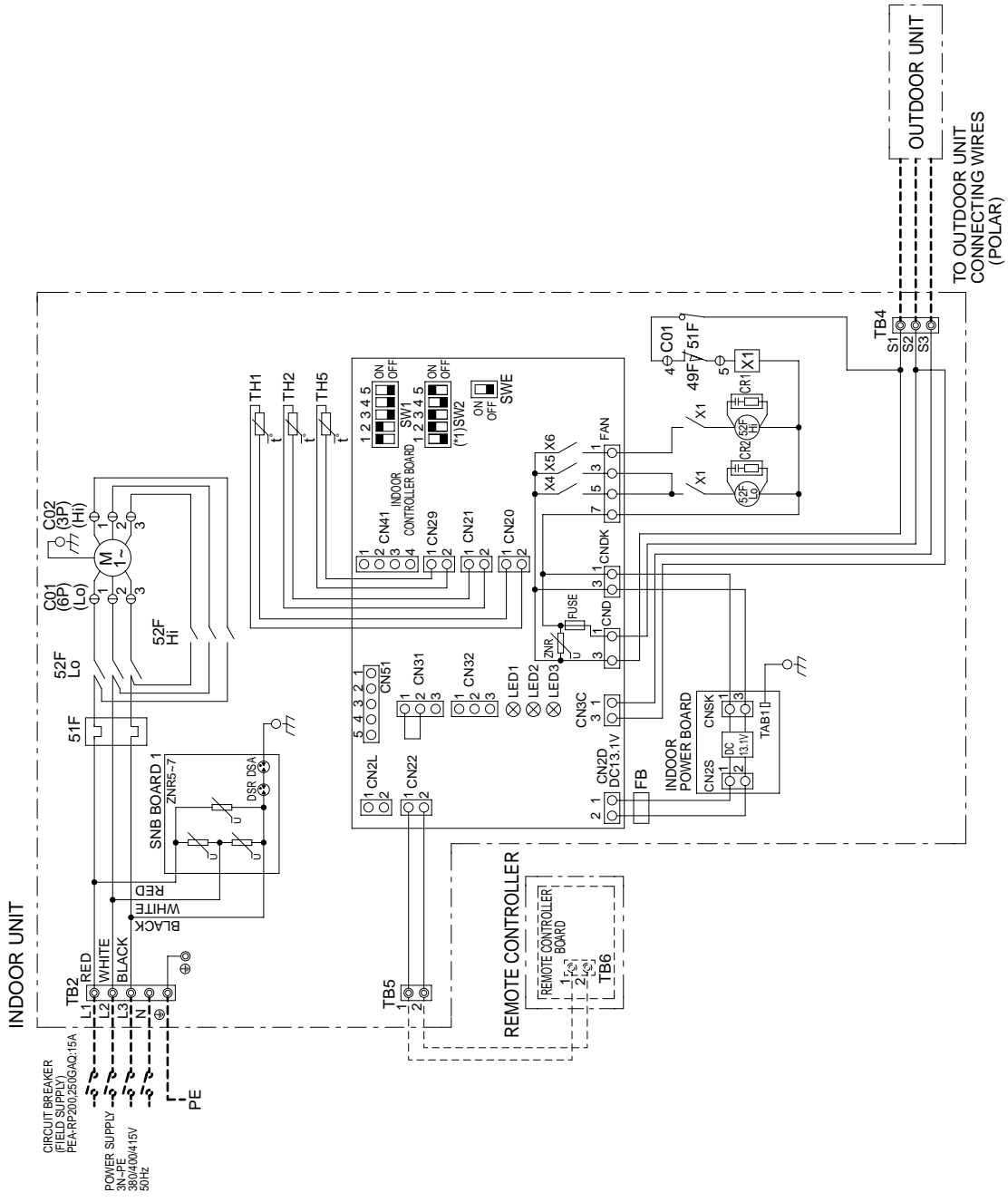

# PEA-RP400,500GAQ

INDOOR UNIT SYMBOL	NAME
MF1	FAN MOTOR (INDOOR)
51F	OVER CURRENT RELAY (INDOOR FAN MOTOR)
52F	MAGNETIC CONTACTOR (INDOOR FAN MOTOR)
49F	INTERNAL THERMOSTAT (INDOOR FAN MOTOR)
TB2-4-1, 4-2, 5	TERMINAL BLOCK
TH1-1, 1-2	ROOM TEMP
TH2-1, 2-2	LIQUID PIPE TEMP
TH5-1, 5-2	CONDEVA TEMP
X1, 2	AUXILIARY RELAY
CR	SURGE KILLER
FB11, FB12	FERRITE CORE
FB21, FB22	FUSE (T6.3AL250V)
INDOOR CONTROLLER BOARD	ZNR VARIATOR
X4-6	AUXILIARY RELAY
SW1	SWITCH (MODEL SELECTION)
SW2	SWITCH (CAPACITY CORD)
SWE	CONNECTOR (EMERGENCY OPERATION)
LED1	LED (POWER SUPPLY)
LED2	LED (POWER SUPPLY <REMOTE CONTROLLER>)
LED3	LED (TRANSMISSION <INDOOR-OUTDOOR>)
CN2L	CONNECTOR (LOSSNAV)
CN31	CONNECTOR (DRAIN SENSOR)
CN32	CONNECTOR (REMOTE SWITCH)
CN41	CONNECTOR (HA TERMINAL-A)
CN51	CONNECTOR (CENTRALLY CONTROL)
SNB BOARD 1 ZNR5-7	VARIATOR
DSA DSR	ARRESTER

OUTDOOR UNIT SYMBOL	NAME
TB3, TB8	TERMINAL BLOCK
REMOTE CONTROLLER BOARD	
SYMBOL	NAME
TB6	TERMINAL BLOCK

- Note: 1. Color of earth wire is yellow and green twisting.  
 2. Specification subject to change without notice.  
 3. Indoor and outdoor connecting wires are made with polarities, make sure matching wiring and terminal.  
 4. Emergency operation.  
 If a trouble occurs with either the remote controller or the indoor microcomputer and no other trouble exists, emergency operation for cooling or heating can be performed by changing the setting of connector (SWE) "ON" on the indoor controller board.  
 SWE : ON / Indoor fan is running high speed.  
 5. Symbols used in wiring diagram above are,  
 ⊕ : CONNECTOR  
 ⊙ : TERMINAL  
 --- (HEAVY DOTTED LINE) : FIELD WIRING  
 - - - (THIN DOTTED LINE) : OPTIONAL PARTS  
 6. (\*1)SW2 shows PEA-RP500 setting. (2places)  
 In case of PEA-RP400 setting is shown as below.



Caution,  
 1. To protect fan motor from abnormal current, over current relays is installed. Therefore, do not change factory set value of over current relays.

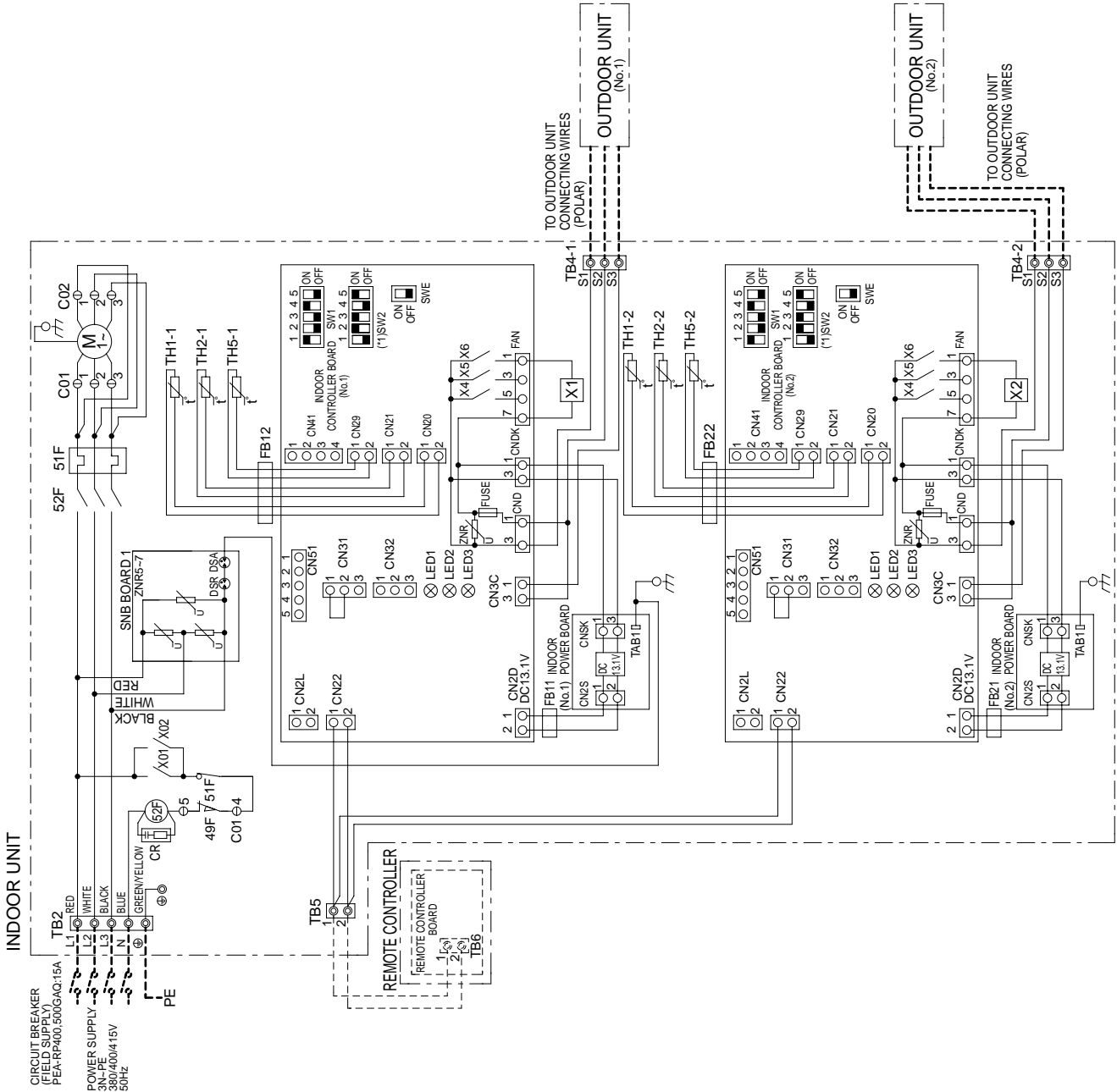

# PEA-RP400,500GAQR1

SYMBOL	NAME
MF1	FAN MOTOR (INDOOR)
51F	OVER CURRENT RELAY (INDOOR FAN MOTOR)
52F	MAGNETIC CONTACTOR (INDOOR FAN MOTOR)
49F	INTERNAL THERMOSTAT (INDOOR FAN MOTOR)
TH1-1,4-2,5	ROOM TEMP
TH1-1,1-2	
TH2-1,2-2	LIQUID PIPE TEMP
TH5-1,5-2	COND/EVA TEMP
X1,2	AUXILIARY RELAY
CR	SURGE KILLER
FB11,FB12	FERRITE CORE
FB21,FB22	
INDOOR CONTROLLER BOARD	FUSE (T6.3AL250V)
ZNR	VARIABLE
X4-6	AUXILIARY RELAY
SW1	SWITCH (MODEL SELECTION)
SW2	SWITCH (CAPACITY CODE)
SWE	CONNECTOR (EMERGENCY OPERATION)
LED1	LED (POWER SUPPLY)
LED2	LED (POWER SUPPLY<REMOTE CONTROLLER>)
LED3	LED (TRANSMISSION<INDOOR/OUTDOOR>)
CN2L	CONNECTOR (LOSSNAY)
CN31	CONNECTOR (DRAIN SENSOR)
CN32	CONNECTOR (REMOTE SWITCH)
CN41	CONNECTOR (H/A TERMINAL-A)
CN51	CONNECTOR (CENTRALLY CONTROL)
SNB BOARD 1	ZNR5-7
DS,ADSR	ARRESTER

SYMBOL	NAME
TB3,TB8	TERMINAL BLOCK

SYMBOL	NAME
TB6	TERMINAL BLOCK

- Note: 1. Color of earth wire is yellow and green twisting.  
 2. Specification subject to change without notice.  
 3. Indoor and outdoor connecting wires are made with polarities, make sure matching wiring and terminal.  
 4. Emergency operation  
 If a trouble occurs with either the remote controller or the indoor microcomputer and no other trouble exists, emergency operation for cooling or heating can be performed by changing the setting of connector (SWE) "ON" on the indoor controller board.  
 SWE :ON / Indoor fan is running high speed.  
 5. Symbols used in wiring diagram above are,  
 ⊖ :CONNECTOR ⊙ :TERMINAL  
 --- (HEAVY DOTTED LINE):FIELD WIRING  
 - - - (THIN DOTTED LINE):OPTIONAL PARTS  
 6. (\*)SW2 shows PEA-RP500 setting.(2places)  
 In case of PEA-RP400 setting is shown as below.

Caution.  
 1. To protect fan motor from abnormal current,over current relays is installed. Therefore, do not change factory set value of over current relays.

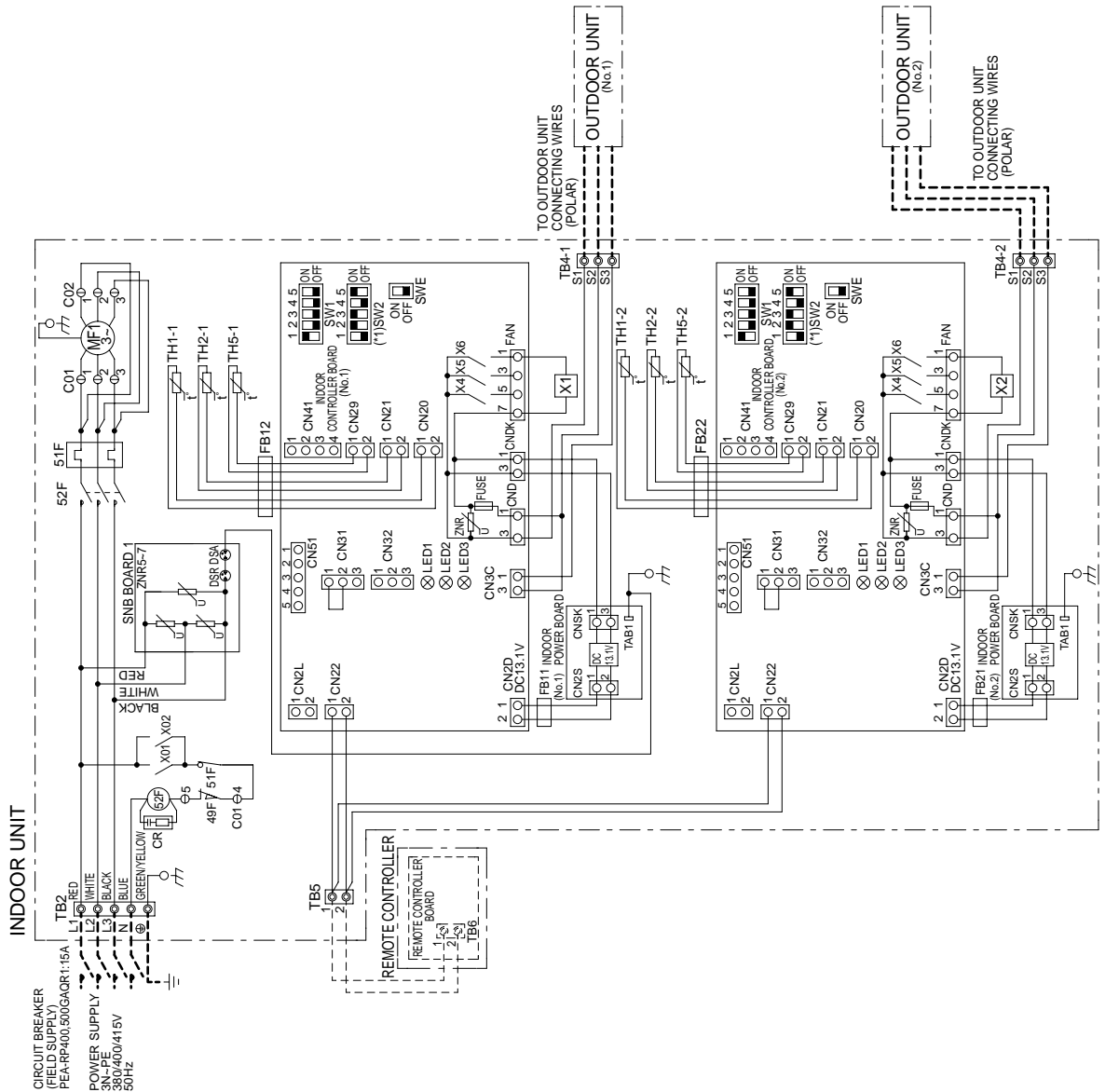

PEA-RP200GAQ PEA-RP250GAQ  
 PEA-RP400GAQ PEA-RP500GAQ

Unit : mm

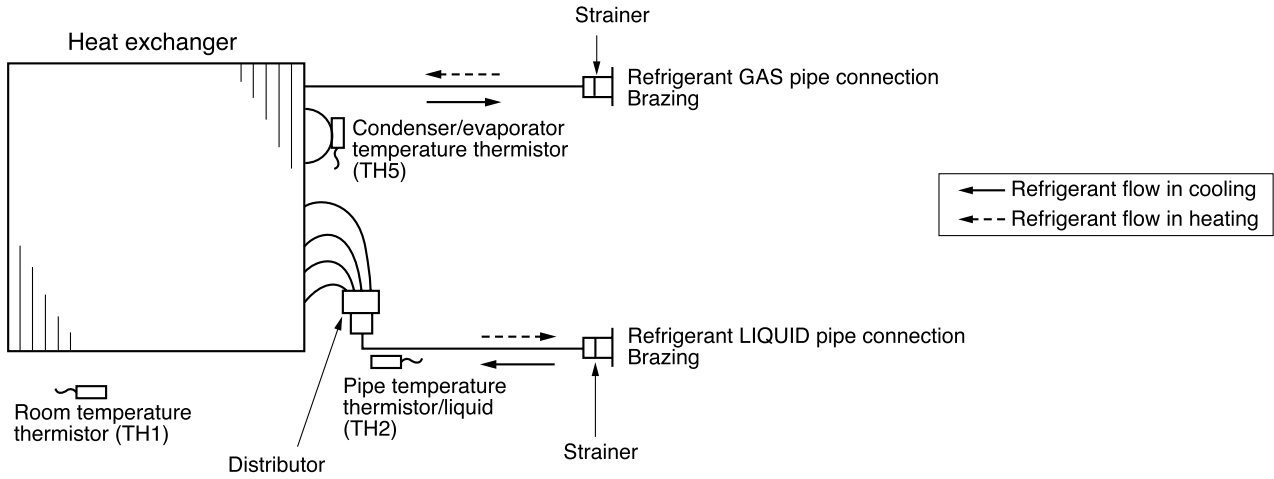

### 9-1. TROUBLESHOOTING

#### <Error code display by self-diagnosis and actions to be taken for service (summary)>

Present and past error codes are logged and displayed on the wired remote controller or controller board of outdoor unit. Actions to be taken for service and the inferior phenomenon reoccurrence at field are summarized in the table below. Check the contents below before investigating details.

Unit conditions at service	Error code	Actions to be taken for service (summary)
The inferior phenomenon is reoccurring.	Displayed	Judge what is wrong and take a corrective action according to "SELF-DIAGNOSIS ACTION TABLE" (9-2).
	Not displayed	Identify the cause of the inferior phenomenon and take a corrective action according to "TROUBLESHOOTING BY INFERIOR PHENOMENA " (9-3).
The inferior phenomenon is not reoccurring.	Logged	<ul style="list-style-type: none"> <li>①Consider the temporary defects such as the work of protection devices in the refrigerant circuit including compressor, poor connection of wiring, noise and etc. Re-check the symptom, and check the installation environment, refrigerant amount, weather when the inferior phenomenon occurred, and wiring related.</li> <li>②Reset error code logs and restart the unit after finishing service.</li> <li>③There is no abnormality in electrical components, controller boards, and remote controller.</li> </ul>
	Not logged	<ul style="list-style-type: none"> <li>①Recheck the abnormal symptom.</li> <li>②Identify the cause of the inferior phenomenon and take a corrective action according to "TROUBLESHOOTING BY INFERIOR PHENOMENA " (9-3).</li> <li>③Continue to operate unit for the time being if the cause is not ascertained.</li> <li>④There is no abnormality in electrical components, controller boards, remote controller etc.</li> </ul>



Note: Refer to the manual of outdoor unit for the details of display such as F, U, and other E.

## 9-2. SELF-DIAGNOSIS ACTION TABLE

Error Code	Meaning of error code and detection method	Cause	Countermeasure
P1	<p><b>Abnormality of room temperature thermistor (TH1)</b></p> <p>① The unit is in three-minute resume prevention mode if short/open of thermistor is detected. Abnormal if the unit does not reset normally after three minutes. (The unit returns to normal operation, if it has normally reset.)</p> <p>② Constantly detected during cooling, drying, and heating operation. Short: 90°C or more Open: -40°C or less</p>	<p>① Defective thermistor characteristics.</p> <p>② Contact failure of connector (CN20) on the indoor controller board. (Insert failure)</p> <p>③ Breaking of wire or contact failure of thermistor wiring.</p> <p>④ Defective indoor controller board.</p>	<p>①~③ Check resistance value of thermistor. 0°C .....15.0kΩ 10°C ....9.6kΩ 20°C ....6.3kΩ 30°C ....4.3kΩ 40°C ....3.0kΩ</p> <p>If you put force on (draw or bend) the lead wire with measuring resistance value of thermistor breaking of wire or contact failure can be detected.</p> <p>② Check contact failure of connector (CN20) on the indoor controller board. Refer to 9-6. Turn the power on again and check restart after inserting connector again.</p> <p>④ Check room temperature display on remote controller. Replace indoor controller board if there is abnormal difference with actual room temperature.</p> <p>Turn the power off, and on again to operate after check.</p>
P2	<p><b>Abnormality of pipe temperature thermistor/Liquid (TH2)</b></p> <p>① The unit is in three-minute resume prevention mode if short/open of thermistor is detected. Abnormal if the unit does not reset normally after three minutes. (The unit returns to normal operation, if it has normally reset.)</p> <p>② Constantly detected during cooling, drying, and heating (except defrosting) operation. Short: 90°C or more Open: -40°C or less</p>	<p>① Defective thermistor characteristics.</p> <p>② Contact failure of connector (CN21) on the indoor controller board. (Insert failure)</p> <p>③ Breaking of wire or contact failure of thermistor wiring.</p> <p>④ Defective refrigerant circuit is causing thermistor temperature of 90°C or more or -40°C or less.</p> <p>⑤ Defective indoor controller board.</p>	<p>①~③ Check resistance value of thermistor. For characteristics, refer to (P1) above.</p> <p>② Check contact failure of connector (CN21) on the indoor controller board. Refer to 9-6. Turn the power on and check restart after inserting connector again.</p> <p>④ Check pipe &lt;liquid&gt; temperature with remote controller in test run mode. If pipe &lt;liquid&gt; temperature is exclusively low (in cooling mode) or high (in heating mode), refrigerant circuit may have defective.</p> <p>⑤ Check pipe &lt;liquid&gt; temperature with remote controller in test run mode. If there is exclusive difference with actual pipe &lt;liquid&gt; temperature, replace indoor controller board.</p> <p>Turn the power off, and on again to operate after check.</p>
P4	<p><b>Abnormality of drain sensor (DS)</b></p> <p>① Suspensive abnormality, if short/open of thermistor is detected for 30 seconds continuously. Turn off compressor and indoor fan.</p> <p>② Short/open is detected for 30 seconds continuously during suspensive abnormality. (The unit returns to normal operation, if it has normally reset.)</p> <p>③ Detect the following condition.</p> <ul style="list-style-type: none"> <li>• During cooling and drying operation.</li> <li>• In case that pipe &lt;liquid&gt; temperature - room temperature &lt;-10deg (Except defrosting)</li> <li>• When pipe &lt;liquid&gt; temperature or room temperature is short/open temperature.</li> <li>• During drain pump operation.</li> </ul>	<p>① Defective thermistor characteristics</p> <p>② Contact failure of connector (CN31) on the indoor controller board. (Insert failure).</p> <p>③ Breaking of wire or contact failure of drain sensor wiring.</p> <p>④ Defective indoor controller board.</p>	<p>①~③ Check resistance value of thermistor. 0°C .....6.0kΩ 10°C ....3.9kΩ 20°C ....2.6kΩ 30°C ....1.8kΩ 40°C ....1.3kΩ</p> <p>② Check contact failure of connector (CN31) on the indoor controller board. Refer to 9-6. Turn the power on again and check restart after inserting connector again.</p> <p>④ Replace indoor controller board if drain pump operates with the line of drain sensor connector CN31-① and ② is short-circuited, and abnormality reappears.</p> <p>Turn the power off, and on again to operate after check.</p>
P5	<p><b>Malfunction of drain pump (DP)</b></p> <p>① Suspensive abnormality, if thermistor of drain sensor is let heat itself and temperature rises slightly. Turn off compressor and indoor fan.</p> <p>② Drain pump is abnormal if the condition above is detected during suspensive abnormality.</p> <p>③ Constantly detected during drain pump operation.</p>	<p>① Malfunction of drain pump</p> <p>② Defective drain Clogged drain pump Clogged drain pipe</p> <p>③ Attached drop of water at the drain sensor</p> <ul style="list-style-type: none"> <li>• Drops of drain trickles from lead wire.</li> <li>• Clogged filter is causing wave of drain.</li> </ul> <p>④ Defective indoor controller board.</p>	<p>① Check if drain-up machine works.</p> <p>② Check drain function.</p> <p>③ Check the setting of lead wire of drain sensor and check clogs of the filter.</p> <p>④ Replace indoor controller board if drain pump operates with the line of drain sensor connector CN31-① and ② is short-circuited and abnormality reappears. Refer to 9-6.</p> <p>Turn the power off, and on again to operate after check.</p>

Error Code	Meaning of error code and detection method	Cause	Countermeasure
P6	<p><b>Freezing/overheating protection is working</b></p> <p>① Freezing protection (Cooling mode) The unit is in six-minute resume prevention mode if pipe &lt;liquid or condenser/evaporator&gt; temperature stays under -15°C for three minutes, three minutes after the compressor started. Abnormal if it stays under -15°C for three minutes again within 16 minutes after six-minute resume prevention mode. &lt;Frost prevention mode&gt; If pipe &lt;liquid or condenser-evaporator&gt; temperature is 2°C or below when 16 minutes has passed after compressor starts operating, unit will start operating in frost prevention mode which stops compressor operation. After that, when pipe &lt;liquid or condenser/evaporator&gt; temperature stays 10°C or more for 3 minutes, frost prevention mode will be released and compressor will restart its operation.</p> <p>② Overheating protection (Heating mode) The units is in six-minute resume prevention mode if pipe &lt;condenser / evaporator&gt; temperature is detected as over 70°C after the compressor started. Abnormal if the temperature of over 70°C is detected again within 10 minutes after six-minute resume prevention mode.</p>	<p>(Cooling or drying mode)</p> <p>① Clogged filter (reduced airflow) ② Short cycle of air path ③ Low-load (low temperature) operation beyond the tolerance range ④ Defective indoor fan motor • Fan motor is defective. • Indoor controller board is defective.</p> <p>⑤ Defective outdoor fan control ⑥ Overcharge of refrigerant ⑦ Defective refrigerant circuit (clogs)</p> <p>(Heating mode)</p> <p>① Clogged filter (reduced airflow) ② Short cycle of air path ③ Over-load (high temperature) operation beyond the tolerance range ④ Defective indoor fan motor • Fan motor is defective. • Indoor controller board is defective.</p> <p>⑤ Defective outdoor fan control ⑥ Overcharge of refrigerant ⑦ Defective refrigerant circuit (clogs) ⑧ Bypass circuit of outdoor unit is defective.</p>	<p>(Cooling or drying mode)</p> <p>① Check clogs of the filter. ② Remove shields.</p> <p>④ Measure the resistance of fan motor's winding. Measure the output voltage of fan's connector (Relay for FAN) on the indoor controller board. *The indoor controller board should be normal when voltage of AC 220~240V is detected while fan motor is connected. Refer to 9-6. ⑤ Check outdoor fan motor. ⑥⑦ Check operating condition of refrigerant circuit.</p> <p>(Heating mode)</p> <p>① Check clogs of the filter. ② Remove shields.</p> <p>④ Measure the resistance of fan motor's winding. Measure the output voltage of fan's connector (Relay for FAN) on the indoor controller board. *The indoor controller board should be normal when voltage of AC 220~240V is detected while fan motor is connected. Refer to 9-6. ⑤ Check outdoor fan motor. ⑥~⑧ Check operating condition of refrigerant circuit.</p>
P8	<p><b>Abnormality of pipe temperature</b> &lt;Cooling mode&gt; Detected as abnormal when the pipe temperature is not in the cooling range 3 minutes later of compressor start and 6 minutes later of the liquid or condenser/evaporator pipe is out of cooling range. Note 1) It takes at least 9 min. to detect. Note 2) Abnormality P8 is not detected in drying mode. Cooling range : -3 deg <math>\geq</math> (TH-TH1) TH: Lower temperature between: liquid pipe temperature (TH2) and condenser/evaporator temperature (TH5) TH1: Intake temperature</p> <p>&lt;Heating mode&gt; When 10 seconds have passed after the compressor starts operation and the hot adjustment mode has finished, the unit is detected as abnormal when condenser/evaporator pipe temperature is not in heating range within 20 minutes.</p> <p>Note 3) It takes at least 27 minutes to detect abnormality. Note 4) It excludes the period of defrosting (Detection restarts when defrosting mode is over) Heating range : 3 deg <math>\leq</math> (TH5-TH1)</p>	<p>① Slight temperature difference between indoor room temperature and pipe &lt;liquid or condenser / evaporator&gt; temperature thermistor • Shortage of refrigerant • Disconnected holder of pipe &lt;liquid or condenser / evaporator&gt; thermistor • Defective refrigerant circuit</p> <p>② Converse connection of extension pipe (on plural units connection)</p> <p>③ Converse wiring of indoor/outdoor unit connecting wire (on plural units connection)</p> <p>④ Defective detection of indoor room temperature and pipe &lt;condenser / evaporator&gt; temperature thermistor</p> <p>⑤ Stop valve is not opened completely.</p>	<p>①~④ Check pipe &lt;liquid or condenser / evaporator&gt; temperature with room temperature display on remote controller and outdoor controller circuit board. Pipe &lt;liquid or condenser / evaporator&gt; temperature display is indicated by setting SW2 of outdoor controller circuit board as follows.</p> <p>( Conduct temperature check with outdoor controller circuit board after connecting 'A-Control Service Tool(PAC-SK52ST)' )</p> <p>②③ Check converse connection of extension pipe or converse wiring of indoor/outdoor unit connecting wire.</p>





Error Code	Meaning of error code and detection method	Cause	Countermeasure
P9	<p><b>Abnormality of pipe temperature thermistor / Condenser-Evaporator (TH5)</b></p> <p>① The unit is in three-minute resume protection mode if short/open of thermistor is detected. Abnormal if the unit does not get back to normal within three minutes. (The unit returns to normal operation, if it has normally reset.)</p> <p>② Constantly detected during cooling, drying, and heating operation (except defrosting) Short: 90°C or more Open: -40°C or less</p>	<p>① Defective thermistor characteristics</p> <p>② Contact failure of connector (CN29) on the indoor controller board. (Insert failure)</p> <p>③ Breaking of wire or contact failure of thermistor wiring.</p> <p>④ Temperature of thermistor is 90°C or more or -40°C or less caused by defective refrigerant circuit.</p> <p>⑤ Defective indoor controller board.</p>	<p>①~③ Check resistance value of thermistor. For characteristics, refer to (P1) above.</p> <p>② Check contact failure of connector (CN29) on the indoor controller board. Refer to 9-6. Turn the power on and check restart after inserting connector again.</p> <p>④ Operate in test run mode and check pipe &lt;condenser / evaporator&gt; temperature with outdoor controller circuit board. If pipe &lt;condenser / evaporator&gt; temperature is exclusively low (in cooling mode) or high (in heating mode), refrigerant circuit may have defective.</p> <p>⑤ Operate in test run mode and check pipe &lt;condenser / evaporator&gt; temperature with outdoor control circuit board. If there is exclusive difference with actual pipe &lt;condenser / evaporator&gt; temperature replace indoor controller board. There is no abnormality if none of above comes within the unit. Turn the power off and on again to operate.</p> <p>( In case of checking pipe temperature with outdoor controller circuit board, be sure to connect A-control service tool (PAC-SK52ST). )</p>
E0 or E4	<p><b>Remote controller transmission error(E0)/signal receiving error(E4)</b></p> <p>① Abnormal if main or sub remote controller can not receive normally any transmission from indoor unit of refrigerant address "0" for three minutes. (Error code : E0)</p> <p>② Abnormal if sub remote controller could not receive for any signal for two minutes. (Error code: E0)</p> <p>① Abnormal if indoor controller board can not receive normally any data from remote controller board or from other indoor controller board for three minutes. (Error code: E4)</p> <p>② Indoor controller board cannot receive any signal from remote controller for two minutes. (Error code: E4)</p>	<p>① Contact failure at transmission wire of remote controller</p> <p>② All remote controllers are set as "sub" remote controller. In this case, E0 is displayed on remote controller, and E4 is displayed at LED (LED1, LED2) on the outdoor controller circuit board.</p> <p>③ Mis-wiring of remote controller.</p> <p>④ Defective transmitting receiving circuit of remote controller</p> <p>⑤ Defective transmitting receiving circuit of indoor controller board of refrigerant address "0".</p> <p>⑥ Noise has entered into the transmission wire of remote controller.</p>	<p>① Check disconnection or looseness of indoor unit or transmission wire of remote controller.</p> <p>② Set one of the remote controllers "main". If there is no problem with the action above.</p> <p>③ Check wiring of remote controller.</p> <ul style="list-style-type: none"> <li>• Total wiring length: max.500m (Do not use cable 3 or more)</li> <li>• The number of connecting indoor units: max.16units</li> <li>• The number of connecting remote controller: max.2units</li> </ul> <p>When it is not the above-mentioned problem of ①~③</p> <p>④ Diagnose remote controllers.</p> <p>a) When "RC OK" is displayed, Remote controllers have no problem. Put the power off, and on again to check. If abnormality generates again, replace indoor controller board.</p> <p>b) When "RC NG" is displayed, Replace remote controller.</p> <p>c) When "RC E3" is displayed,</p> <p>d) When "ERC 00-06" is displayed, [ c),d)→Noise may be causing abnormality. ]</p> <p>* If the unit is not normal after replacing indoor controller board in group control, indoor controller board of address "0" may be abnormal.</p>
E3 or E5	<p><b>Remote controller transmission error(E3)/signal receiving error(E5)</b></p> <p>① Abnormal if remote controller could not find blank of transmission path for six seconds and could not transmit. (Error code: E3)</p> <p>② Remote controller receives transmitted data at the same time, compares the data, and when detecting it, judges different data to be abnormal 30 continuous times. (Error code: E3)</p> <p>① Abnormal if indoor controller board could not find blank of transmission path. (Error code: E5)</p> <p>② Indoor controller board receives transmitted data at the same time, compares the data, and when detecting it, judges different data to be abnormal 30 continuous times. (Error code: E5)</p>	<p>① Two remote controller are set as "main." (In case of 2 remote controllers)</p> <p>② Remote controller is connected with two indoor units or more.</p> <p>③ Repetition of refrigerant address.</p> <p>④ Defective transmitting receiving circuit of remote controller.</p> <p>⑤ Defective transmitting receiving circuit of indoor controller board.</p> <p>⑥ Noise has entered into transmission wire of remote controller.</p>	<p>① Set a remote controller to main, and the other to sub.</p> <p>② Remote controller is connected with only one indoor unit.</p> <p>③ The address changes to a separate setting.</p> <p>④~⑥ Diagnose remote controller.</p> <p>a) When "RC OK" is displayed, remote controllers have no problem. Put the power off, and on again to check. When becoming abnormal again, replace indoor controller board.</p> <p>b) When "RC NG" is displayed, replace remote controller.</p> <p>c) When "RC E3" or "ERC 00-66" is displayed, noise may be causing abnormality.</p>





Error Code	Meaning of error code and detection method	Cause	Countermeasure
E6	<p><b>Indoor/outdoor unit communication error (Signal receiving error)</b></p> <p>① Abnormal if indoor controller board cannot receive any signal normally for six minutes after putting the power on.</p> <p>② Abnormal if indoor controller board cannot receive any signal normally for three minutes.</p> <p>③ Consider the unit abnormal under the following condition: When two or more indoor units are connected to one outdoor unit, indoor controller board cannot receive a signal for three minutes from outdoor controller circuit board, a signal which allows outdoor controller circuit board to transmit signals.</p>	<p>① Contact failure, short circuit or, mis-wiring (converse wiring) of indoor/outdoor unit connecting wire</p> <p>② Defective transmitting receiving circuit of indoor controller board</p> <p>③ Defective transmitting receiving circuit of indoor controller board</p> <p>④ Noise has entered into indoor/outdoor unit connecting wire.</p>	<p>* Check LED display on the outdoor control circuit board. (Connect A-control service tool, PAC-SK52ST.) Refer to EA-EC item if LED displays EA-EC.</p> <p>① Check disconnection or looseness of indoor/outdoor unit connecting wire of indoor unit or outdoor unit. Check all the units in case of twin triple indoor unit system.</p> <p>②-④ Turn the power off, and on again to check. If abnormality generates again, replace indoor controller board or outdoor controller circuit board.</p> <p>* Other indoor controller board may have defective in case of twin triple indoor unit system.</p>
E7	<p><b>Indoor/outdoor unit communication error (Transmitting error)</b></p> <p>Abnormal if "1" receiving is detected 30 times continuously though indoor controller board has transmitted "0".</p>	<p>① Defective transmitting receiving circuit of indoor controller board</p> <p>② Noise has entered into power supply.</p> <p>③ Noise has entered into outdoor control wire.</p>	<p>①-③ Turn the power off, and on again to check. If abnormality generates again, replace indoor controller board.</p>
Fb	<p><b>Abnormality of indoor controller board</b></p> <p>Abnormal if data cannot be normally read from the nonvolatile memory of the indoor controller board.</p>	<p>① Defective indoor controller board.</p>	<p>① Replace indoor controller board.</p>
E1 or E2	<p><b>Abnormality of remote controller control board</b></p> <p>① Abnormal if data cannot be normally read from the nonvolatile memory of the remote controller control board. (Error code: E1)</p> <p>② Abnormal if the clock function of remote controller cannot be normally operated. (Error code: E2)</p>	<p>① Defective remote controller.</p>	<p>① Replace remote controller.</p>
PA (2502) (2500)	<p><b>Forced compressor stop (due to water leakage abnormality)</b></p> <p>① When the intake temperature subtracted with liquid pipe temperature is less than -10°C, drain sensor is detected whether it is soaked in the water or not at the interval of 90 seconds. (Drain pump will start operating when the drain sensor is detected to be soaked in the water.)</p> <p>② The unit has a water leakage abnormality when the following conditions, a and b, are satisfied while the above-mentioned detection is performed.</p> <p>a) The drain sensor is detected to be soaked in the water 10 times in a row.</p> <p>b) The intake temperature subtracted with liquid pipe temperature is detected to be less than -10°C for a total of 30 minutes. (When the drain sensor is detected to be NOT soaked in the water, the detection record of a and b will be cleared.)</p> <p>③ The drain sensor detection is performed in operations other than cooling. (When the unit stops operating, during heating or fan operation, when the unit stops because of some abnormality)</p> <p>*Once the water leakage abnormality is detected, abnormality state will not be released until the main power is reset.</p>	<p>1) Drain pump trouble</p> <p>2) Drain defective</p> <ul style="list-style-type: none"> <li>· Drain pump clogging</li> <li>· Drain pipe clogging</li> </ul> <p>3) Open circuit of drain sensor side heater</p> <p>4) Contact failure of drain sensor connector</p> <p>5) Dew condensation on drain sensor</p> <ul style="list-style-type: none"> <li>· Drain water descends along lead wire.</li> <li>· Drain water waving due to filter clogging.</li> </ul> <p>6) Extension piping connection difference at twin, triple, quadruple system.</p> <p>7) Mis-wiring of indoor/ outdoor connecting at twin, triple, quadruple system.</p> <p>8) Room temperature thermistor / liquid pipe temperature thermistor detection is defective.</p>	<p>Check the drain pump. Performance Please confirm whether water can be drained.</p> <p>Confirm the resistance of the drain sensor side heater.</p> <p>Check the connector contact failure.</p> <p>① Check the drain sensor leadwire mounted. ② Check the filter clogging</p> <p>Check the piping connection.</p> <p>Check the indoor/ outdoor connecting wires.</p> <p>Check the room temperature display of remote controller. Check the indoor liquid pipe temperature display of outdoor controller board.</p>

### 9-3. TROUBLESHOOTING BY INFERIOR PHENOMENA

Note: Refer to the manual of outdoor unit for the detail of remote controller.

Phenomena	Cause	Countermeasure
<p><b>(1)LED2 on indoor controller board is off.</b></p>	<ul style="list-style-type: none"> <li>• When LED1 on indoor controller board is also off.</li> <li>① Power supply of rated voltage is not supplied to outdoor unit.</li> <li>② Defective outdoor controller circuit board.</li> <li>③ Power supply of 220~240V is not supplied to indoor unit.</li> <li>④ Defective indoor power board.</li> <li>⑤ Defective indoor controller board.</li> </ul> <p><b>(For the separate indoor/outdoor unit power supply system)</b></p> <ul style="list-style-type: none"> <li>① Power supply of 220~240V AC is not supplied to indoor unit.</li> <li>② The connectors of the optional replacement kit are not used.</li> <li>③ Defective indoor controller board.</li> <li>④ Defective indoor power board.</li> </ul>	<ul style="list-style-type: none"> <li>① Check the voltage of outdoor power supply terminal block (L, N) or (L<sub>3</sub>, N). <ul style="list-style-type: none"> <li>• When AC 220~240V is not detected. Check the power wiring to outdoor unit and the breaker.</li> <li>• When AC 220~240V is detected. —Check ② (below).</li> </ul> </li> <li>② Check the voltage between outdoor terminal block S1 and S2. <ul style="list-style-type: none"> <li>• When AC 220~240V is not detected. Check the fuse on outdoor controller circuit board. Check the wiring connection.</li> <li>• When AC 220~240V is detected. —Check ③ (below).</li> </ul> </li> <li>③ Check the voltage between indoor terminal block S1 and S2. <ul style="list-style-type: none"> <li>• When AC 220~240V is not detected. Check indoor/outdoor unit connecting wire for mis-wiring.</li> <li>• When AC 220~240V is detected. —Check ④ (below).</li> </ul> </li> <li>④ Check voltage output from CN2S on indoor power board (DC13.1V). Refer to 9-6-1. <ul style="list-style-type: none"> <li>• When no voltage is output. Check the wiring connection.</li> <li>• When output voltage is between DC12.5V and DC13.7V. —Check ⑤ (below).</li> </ul> </li> <li>⑤ Check the wiring connection between indoor controller board and indoor power board. Check the fuse on indoor controller board. If no problems are found, indoor controller board is defective.</li> </ul> <ul style="list-style-type: none"> <li>① Check the voltage of indoor power supply terminal block (S1, S2). <ul style="list-style-type: none"> <li>• When AC220~240V is not detected. Check the power supply wiring.</li> <li>• When AC220~240V is detected. —Check ② (below).</li> </ul> </li> <li>② Check that there is no problem in the method of connecting the connectors. <ul style="list-style-type: none"> <li>• When there are problems in the method of connecting the connectors. Connect the connector correctly referring to installation manual of an optional kit.</li> <li>• When there is no problem in the method of connecting the connectors. —Check ③ (below).</li> </ul> </li> <li>③ Check voltage output from CNDK on indoor controller board. <ul style="list-style-type: none"> <li>• When AC220~240V is not detected. Check the fuse on indoor controller board. Check the wiring connection between indoor power supply terminal block and CND on indoor controller board.</li> <li>• When AC220~240V is detected. —Check ④ (below).</li> </ul> </li> <li>④ Check voltage output from CN2S on indoor power board. <ul style="list-style-type: none"> <li>• When no voltage output. Check the wiring connection between CNDK on indoor controller board and CNSK on indoor power board. If no problem are found, indoor power board is defective.</li> <li>• When DC12.5~13.7V is detected. Check the wiring connection between CN2S on indoor power board and CN2D on indoor power board. If no problem are found, indoor controller board is defective.</li> </ul> </li> </ul>
	<ul style="list-style-type: none"> <li>• When LED1 on indoor controller board is lit.</li> <li>① Mis-setting of refrigerant address for outdoor unit (There is no unit corresponding to refrigerant address "0".)</li> </ul>	<ul style="list-style-type: none"> <li>① Reconfirm the setting of refrigerant address for outdoor unit. Set the refrigerant address to "0". (For grouping control system under which 2 or more outdoor units are connected, set one of the units to "0".) Set refrigerant address using SW1 (3-6) on outdoor controller circuit board.</li> </ul>

Note: Refer to the manual of outdoor unit for the detail of remote controller.

Phenomena	Cause	Countermeasure
(2)LED2 on indoor controller board is blinking.	<ul style="list-style-type: none"> <li>• When LED1 on indoor controller board is also blinking. Connection failure of indoor/outdoor unit connecting wire</li> </ul>	Check indoor/outdoor unit connecting wire for connection failure.
	<ul style="list-style-type: none"> <li>• When LED1 is lit.</li> <li>① Mis-wiring of remote controller wires Under twin triple indoor unit system, 2 or more indoor units are wired together.</li> <li>② Refrigerant address for outdoor unit is wrong or not set. Under grouping control system, there are some units whose refrigerant address is 0.</li> <li>③ Short-cut of remote controller wires</li> <li>④ Defective remote controller</li> </ul>	<ul style="list-style-type: none"> <li>① Check the connection of remote controller wires in case of twin triple indoor unit system. When 2 or more indoor units are wired in one refrigerant system, connect remote controller wires to one of those units.</li> <li>② Check the setting of refrigerant address in case of grouping control system. If there are some units whose refrigerant addresses are 0 in one group, set one of the units to 0 using SW1 (3-6) on outdoor controller circuit board.</li> <li>③④ Remove remote controller wires and check LED2 on indoor controller board. <ul style="list-style-type: none"> <li>• When LED2 is blinking, check the short-cut of remote controller wires.</li> <li>• When LED2 is lit, connect remote controller wires again and: if LED2 is blinking, remote controller is defective; if LED2 is lit, connection failure of remote controller terminal block etc. has returned to normal.</li> </ul> </li> </ul>

#### 9-4. WHEN WIRED REMOTE CONTROLLER OR INDOOR UNIT MICRO COMPUTER TROUBLES

1. If there is not any other wrong when trouble occurs, emergency operation starts as the indoor controller board switch (SWE) is set to ON.  
During the emergency operation the indoor unit is as follows;
  - (1) Indoor fan high speed operation
  - (2) Drain-up machine operation
2. When emergency operating for COOL or HEAT, setting of the switch (SWE) on the indoor controller board and outdoor unit emergency operation are necessary.
3. Check items and notices as the emergency operation
  - (1) Emergency operation cannot be used as follows;
    - When the outdoor unit is something wrong.
    - When the indoor fan is something wrong.
    - When drain over flow protected operation is detected during self-diagnosis. (Error code : P5)
  - (2) Emergency operation will be serial operation by the power supply ON/OFF.  
ON/OFF or temperature, etc. adjustment is not operated by the remote controller.
  - (3) Do not operate for a long time as cold air is blown when the outdoor unit starts defrosting operation during heat emergency operation.
  - (4) Cool emergency operation must be within 10 hours. Other wise, heat exchanger of indoor unit may get frosted.
  - (5) After completing the emergency operation, return the switch setting, etc. in former state.
  - (6) Since vane does not work at emergency operation, position the vane slowly by hand.

## 9-5. HOW TO CHECK THE PARTS

**PEA-RP200GAQ PEA-RP250GAQ**  
**PEA-RP400GAQ PEA-RP500GAQ**

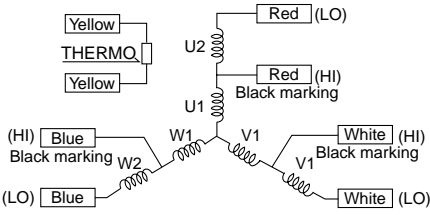
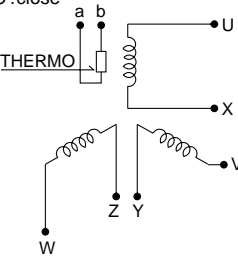
Parts name	Check points																			
Room temperature thermistor (TH1) Pipe temperature thermistor/liquid (TH2) Condenser/evaporator temperature thermistor (TH5)	Disconnect the connector then measure the resistance using a tester. (Surrounding temperature 10°C~30°C) <table border="1" data-bbox="561 499 1072 577"> <thead> <tr> <th>Normal</th> <th>Abnormal</th> </tr> </thead> <tbody> <tr> <td>4.3kΩ~9.6kΩ</td> <td>Open or short</td> </tr> </tbody> </table> (Refer to the thermistor)	Normal	Abnormal	4.3kΩ~9.6kΩ	Open or short															
Normal	Abnormal																			
4.3kΩ~9.6kΩ	Open or short																			
<b>Fan motor</b> •PEA-RP200/250GAQ Thermal protector trip temperature 135 ±5°C : open 86 ±15°C : close  PEA-RP200GAQ.TH-AF PEA-RP250GAQ.TH-AF PEA-RP200GAQR2.TH-AF PEA-RP250GAQR2.TH-AF    •PEA-RP400/500GAQ PEA-RP400GAQ.TH-AF PEA-RP400GAQR1.TH-AF PEA-RP500GAQ.TH-AF PEA-RP500GAQR1.TH-AF Thermal protector trip temperature 150 ±5°C : open 96 ±15°C : close  	Measure the resistance value across the terminals with a multimeter. (Winding temperature 20 °C) <table border="1" data-bbox="561 739 1391 1243"> <thead> <tr> <th></th> <th colspan="2">Normal</th> <th>Abnormal</th> </tr> </thead> <tbody> <tr> <td rowspan="2">PEA-RP200/250GAQ PEA-RP200GAQ.TH-AF PEA-RP250GAQ.TH-AF PEA-RP200GAQR2.TH-AF PEA-RP250GAQR2.TH-AF</td> <td>Hi</td> <td>Red-White / White-Blue / Red-Blue</td> <td>20.6Ω</td> <td rowspan="4">Open or short</td> </tr> <tr> <td>Lo</td> <td>Red-White / White-Blue / Red-Blue</td> <td>25.6Ω</td> </tr> <tr> <td rowspan="2">PEA-RP400GAQ PEA-RP400GAQ.TH-AF PEA-RP400GAQR1.TH-AF</td> <td>△</td> <td>Red-White / White-Blue / Red-Blue</td> <td>34.2Ω</td> </tr> <tr> <td>△</td> <td>Red-White / White-Blue / Red-Blue</td> <td>25.2Ω</td> </tr> </tbody> </table>		Normal		Abnormal	PEA-RP200/250GAQ PEA-RP200GAQ.TH-AF PEA-RP250GAQ.TH-AF PEA-RP200GAQR2.TH-AF PEA-RP250GAQR2.TH-AF	Hi	Red-White / White-Blue / Red-Blue	20.6Ω	Open or short	Lo	Red-White / White-Blue / Red-Blue	25.6Ω	PEA-RP400GAQ PEA-RP400GAQ.TH-AF PEA-RP400GAQR1.TH-AF	△	Red-White / White-Blue / Red-Blue	34.2Ω	△	Red-White / White-Blue / Red-Blue	25.2Ω
	Normal		Abnormal																	
PEA-RP200/250GAQ PEA-RP200GAQ.TH-AF PEA-RP250GAQ.TH-AF PEA-RP200GAQR2.TH-AF PEA-RP250GAQR2.TH-AF	Hi	Red-White / White-Blue / Red-Blue	20.6Ω	Open or short																
	Lo	Red-White / White-Blue / Red-Blue	25.6Ω																	
PEA-RP400GAQ PEA-RP400GAQ.TH-AF PEA-RP400GAQR1.TH-AF	△	Red-White / White-Blue / Red-Blue	34.2Ω																	
	△	Red-White / White-Blue / Red-Blue	25.2Ω																	

<Thermistor Characteristic graph>

Thermistor for lower temperature

- Room temperature thermistor(TH1)
- Pipe temperature thermistor/liquid(TH2)
- Condenser/Evaporator temperature thermistor(TH5)

Thermistor  $R_0=15k\Omega \pm 3\%$

Fixed number of  $B=3480 \pm 2\%$

$$R_t=15\exp \left\{ 3480 \left( \frac{1}{273+t} - \frac{1}{273} \right) \right\}$$

0°C	15kΩ
10°C	9.6kΩ
20°C	6.3kΩ
25°C	5.2kΩ
30°C	4.3kΩ
40°C	3.0kΩ

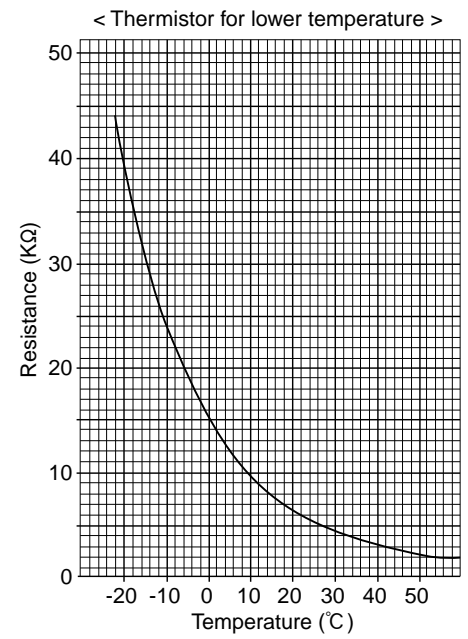

## 9-6. TEST POINT DIAGRAM

### 9-6-1. Power board

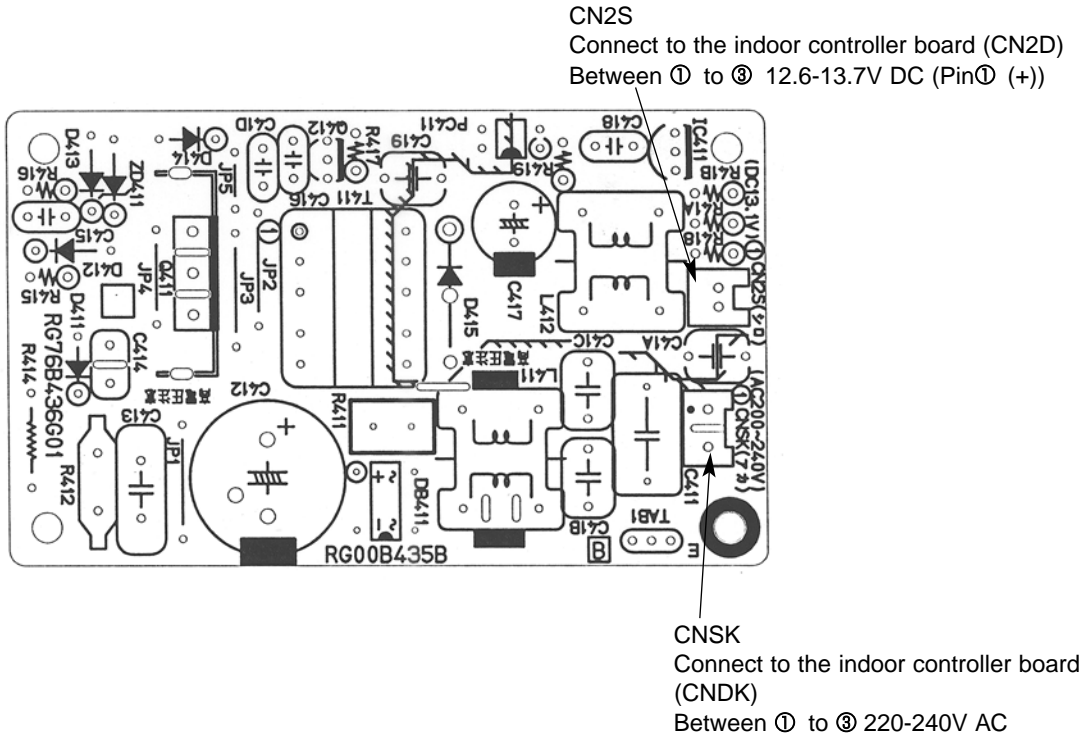











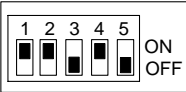

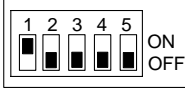
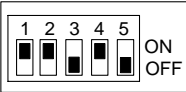

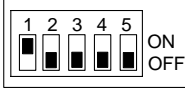
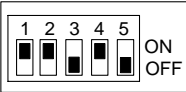

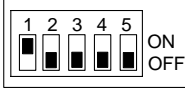
## 9-7. FUNCTIONS OF DIP SWITCH AND JUMPER WIRE

Each function is controlled by the dip switch and the jumper wire on control p.c. board.

(Marks in the table below) Jumper wire (○ : Short × : Open)

Jumper wire	Functions	Setting by the dip switch and jumper wire	Remarks						
SW1	Model settings	<table border="0"> <tr> <td> <b>PEA-RP200/250</b>                      PEA-RP200GAQ.TH-AF                      PEA-RP250GAQ.TH-AF   </td> <td> <b>PEA-RP400/500</b>                      PEA-RP400GAQ.TH-AF                      PEA-RP500GAQ.TH-AF   </td> </tr> <tr> <td> <b>PEA-RP200GAQR2.TH-AF</b>                      PEA-RP250GAQR2.TH-AF   </td> <td> <b>PEA-RP400GAQR1.TH-AF</b>                      PEA-RP500GAQR1.TH-AF   </td> </tr> </table>	<b>PEA-RP200/250</b> PEA-RP200GAQ.TH-AF PEA-RP250GAQ.TH-AF 	<b>PEA-RP400/500</b> PEA-RP400GAQ.TH-AF PEA-RP500GAQ.TH-AF 	<b>PEA-RP200GAQR2.TH-AF</b> PEA-RP250GAQR2.TH-AF 	<b>PEA-RP400GAQR1.TH-AF</b> PEA-RP500GAQR1.TH-AF 			
<b>PEA-RP200/250</b> PEA-RP200GAQ.TH-AF PEA-RP250GAQ.TH-AF 	<b>PEA-RP400/500</b> PEA-RP400GAQ.TH-AF PEA-RP500GAQ.TH-AF 								
<b>PEA-RP200GAQR2.TH-AF</b> PEA-RP250GAQR2.TH-AF 	<b>PEA-RP400GAQR1.TH-AF</b> PEA-RP500GAQR1.TH-AF 								
SW2	Capacity settings	<table border="0"> <tr> <td> <b>PEA-RP200/400</b>   </td> <td> <b>PEA-RP250/500</b>   </td> </tr> </table>	<b>PEA-RP200/400</b> 	<b>PEA-RP250/500</b> 					
<b>PEA-RP200/400</b> 	<b>PEA-RP250/500</b> 								
JP1	Unit type setting	<table border="1"> <thead> <tr> <th>Model</th> <th>JP1</th> </tr> </thead> <tbody> <tr> <td>Without TH5</td> <td>○</td> </tr> <tr> <td>With TH5</td> <td>×</td> </tr> </tbody> </table>	Model	JP1	Without TH5	○	With TH5	×	There is no jumper (JP1) because these models have the cond./eva. temperature thermistor (TH5).
Model	JP1								
Without TH5	○								
With TH5	×								
JP3	Indoor controller board type setting	<table border="1"> <thead> <tr> <th>Indoor controller board type</th> <th>JP3</th> </tr> </thead> <tbody> <tr> <td>Factory shipment</td> <td>×</td> </tr> <tr> <td>Service parts</td> <td>○</td> </tr> </tbody> </table>	Indoor controller board type	JP3	Factory shipment	×	Service parts	○	
Indoor controller board type	JP3								
Factory shipment	×								
Service parts	○								



# 10 SERVICE DATA (PARTS NAME)

## PEA-RP200/250GAQ

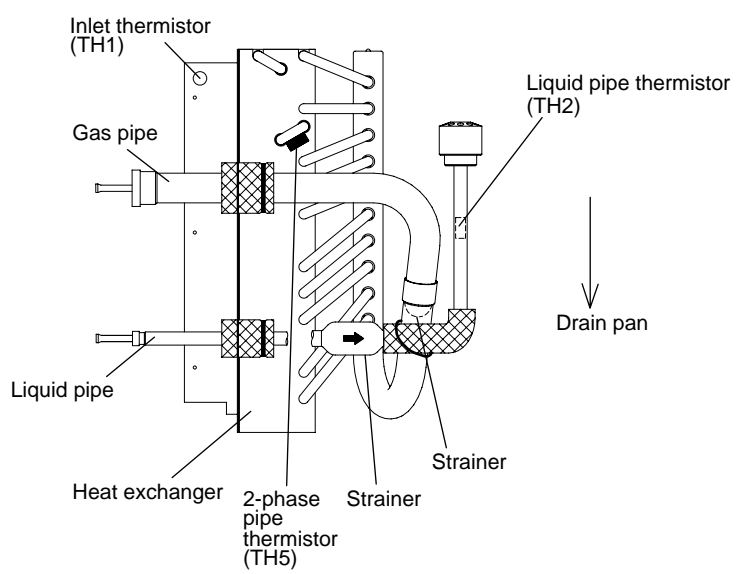
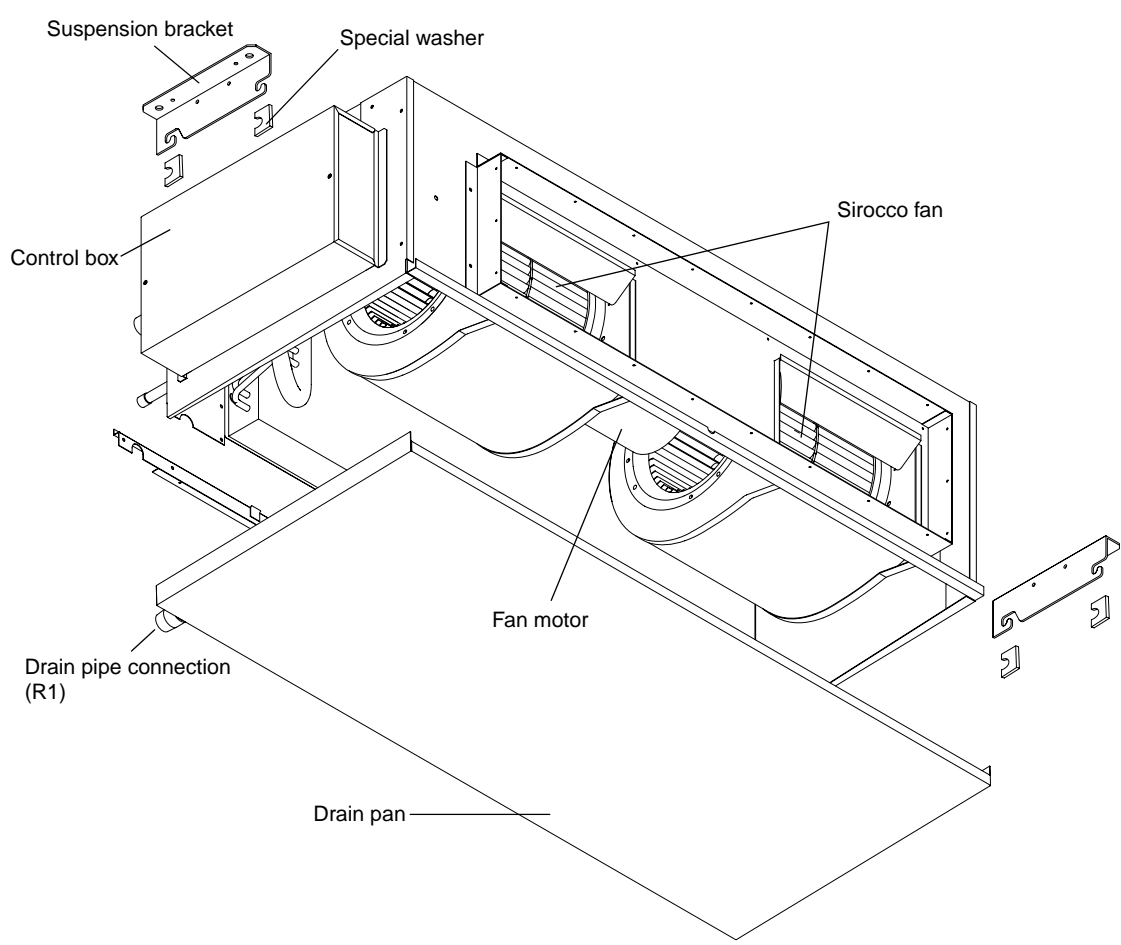

# PEA-RP400/500GAQ

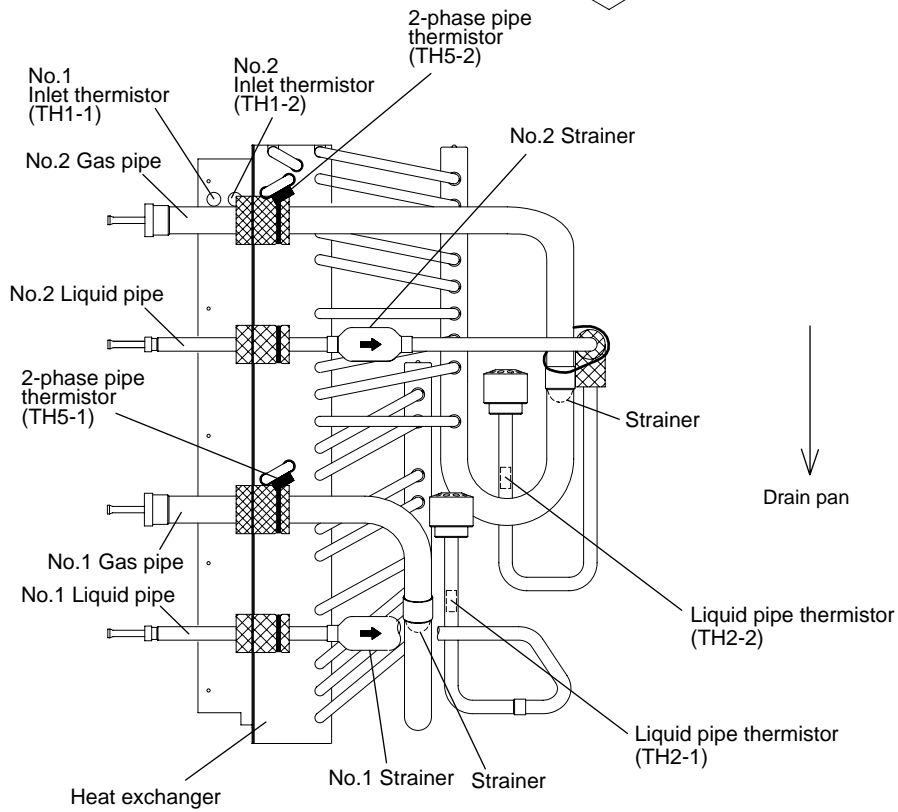
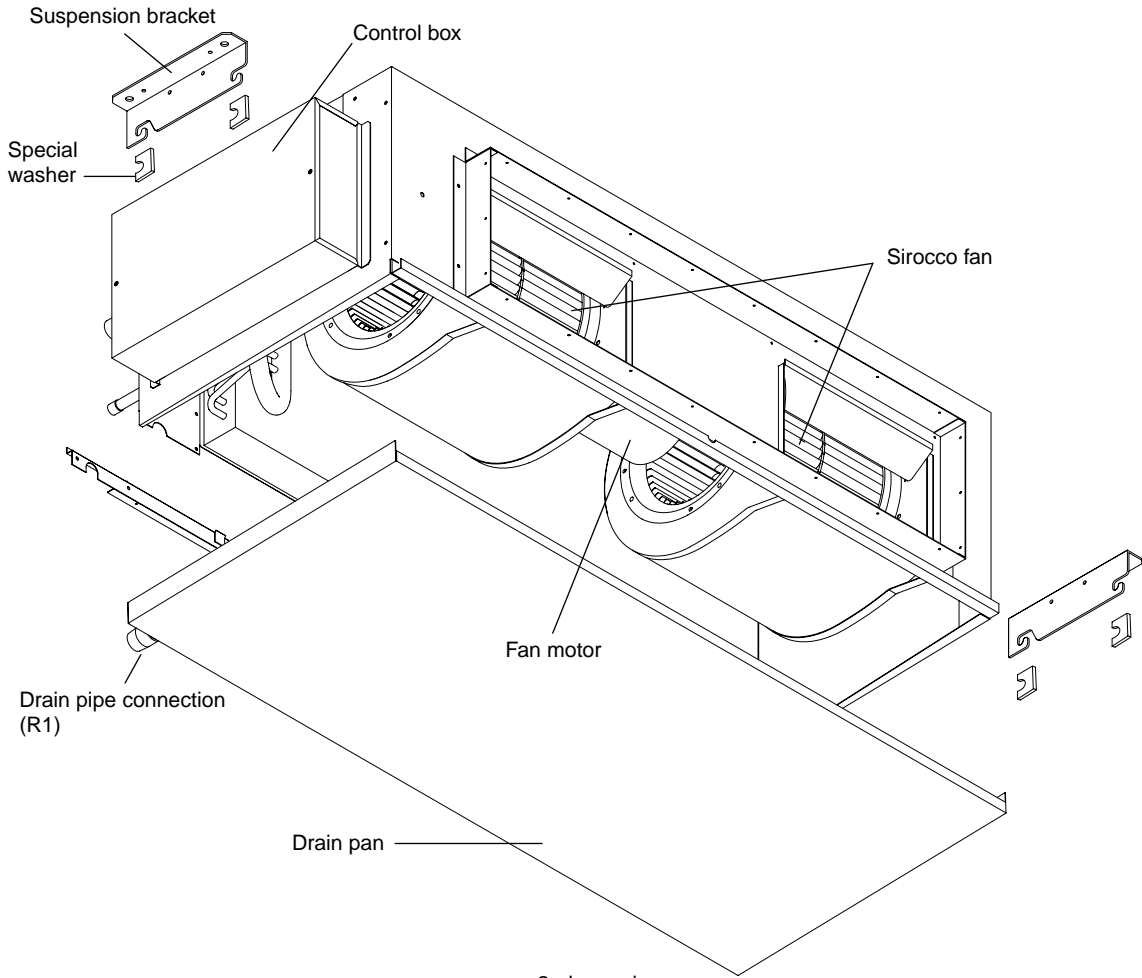

# PEA-RP200/250GAQ

PEA-RP200GAQ.TH-AF  
 PEA-RP250GAQ.TH-AF  
 PEA-RP200GAQR2.TH-AF  
 PEA-RP250GAQR2.TH-AF

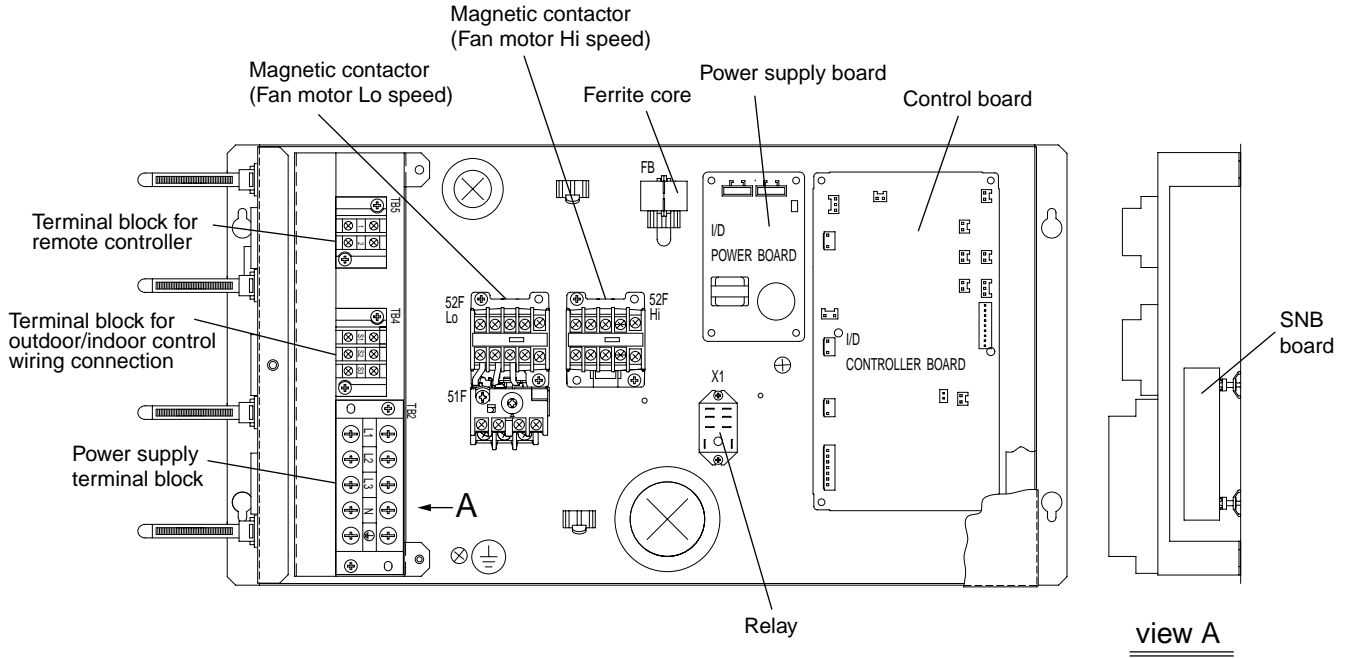

# PEA-RP400/500GAQ

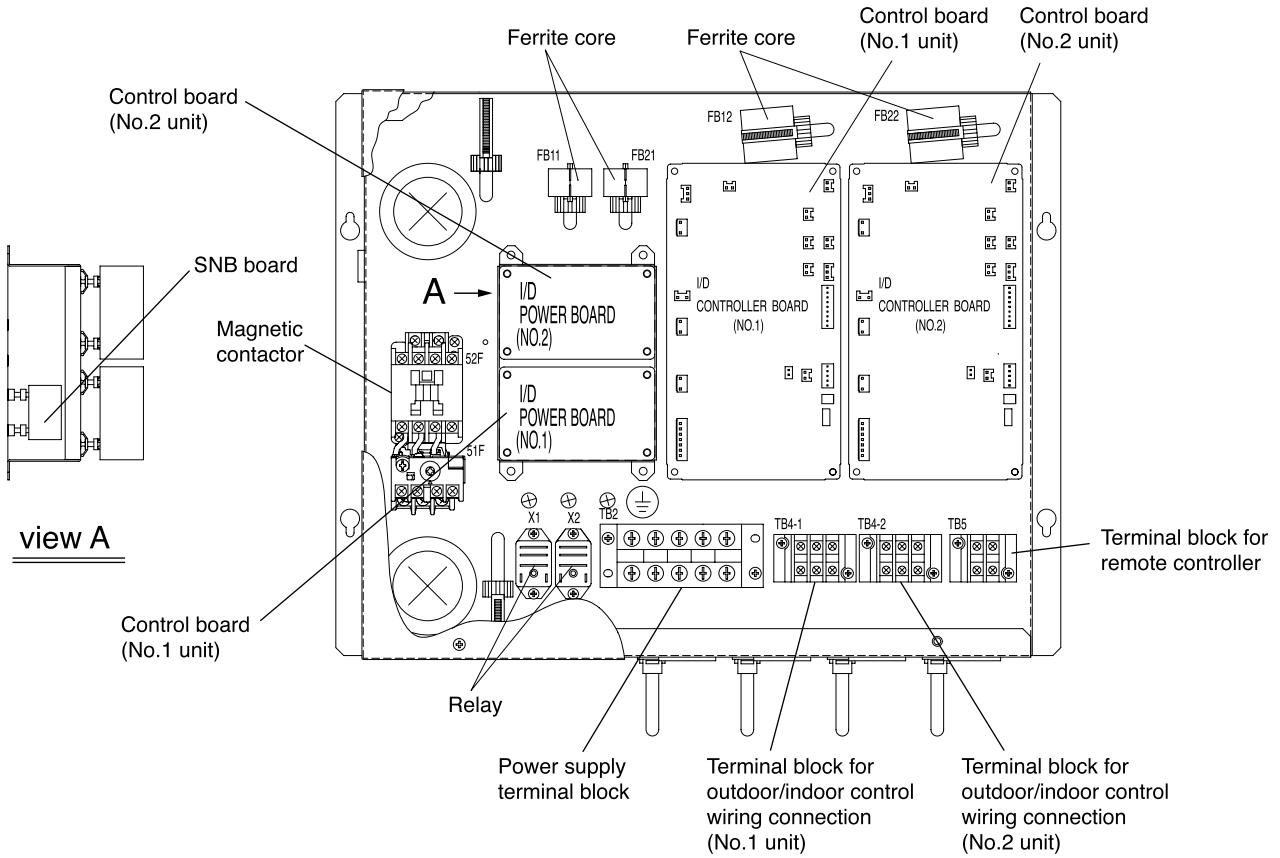

# **mitsubishi electric corporation**

---