

Panasonic

DVCPRO PV Series Line-up Catalog

PV series

DVCPRO

(NTSC: 525)

The DVCPRO PV Series Brings the Incredible Potential of Digital Video to Even More Professionals



Panasonic's DVCPRO equipment has earned wide acclaim, as evidenced by its Emmy Awards, and its superior picture and sound quality, reliability and cost-performance have made it the choice of broadcasters all around the world. Now a new line of equipment, the DVCPRO PV series, brings DVCPRO's many advantages to video professionals in a variety of fields.

Originally developed to meet broadcasting needs, DVCPRO combines superior digital performance with low maintenance costs. The extended recording time and compact, lightweight design of DVCPRO camera/recorders make them ideal not only for news gathering, but for events various applications such as wedding, school use, business presentation, and other professional use.

DVCPRO is flexible, too, letting you configure systems that meet your specific needs while providing digital editing and broadcast-level picture and sound quality.

The new series gives you DVCPRO's acclaimed performance at a price every professional will appreciate.

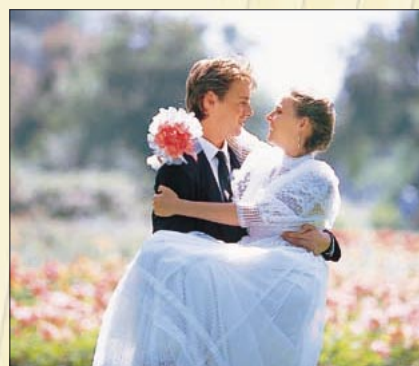

Why Professionals Prefer DVCPRO?

1 The World-Standard Digital Format

DVCPRO's superb picture and sound quality is recognized the world over. The DVCPRO family extends from a wide line of broadcasting equipment, to the new series that brings broadcast-level quality to professionals in any field. Upward compatibility adds to the convenience of this versatile, future-proof format.

2 Small Mechanism and Low Maintenance Costs

DVCPRO's small mechanism has gained the recognition of the world's broadcasters as a highly reliable mechanism. Its maintenance costs are minimal and its high

durability is well-known. With DVCPRO, the costs for equipment and maintenance are greatly reduced.

3 Reliable Compact Cassettes with Extended Recording Time

DVCPRO's metal particle tapes are small in size yet offer extended recording time and long storage life. Both tape costs and storage space requirements are reduced. The metal particle tapes, which have proven themselves in broadcast use, combine high rigidity and excellent resistance to oxidation, to provide outstanding reliability even after repeated use or long-term storage.

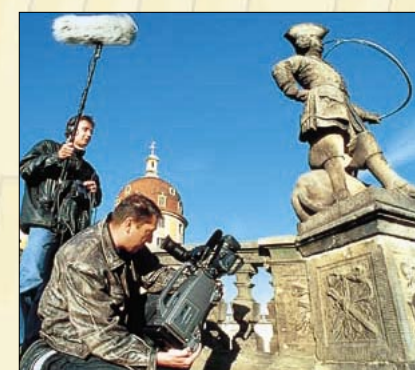

DVCPRO
The Emmy Award
Winning Format



AJ-D610WA
2/3" IT 3CCD DVCPRO Camera/Recorder

AJ-D400
1/2" FIT 3CCD DVCPRO Camera/Recorder

AJ-D215
1/3" IT 3CCD DVCPRO Camera/Recorder

AJ-D440
DVCPRO Studio Player



AJ-D450
DVCPRO Studio VCR

AJ-D250
DVCPRO Desktop Editing VCR

AJ-D230H
DVCPRO Desktop VCR



AJ-A250
Editing Controller

AG-EZ30U
3-CCD DV Camera/Recorder

AG-DV2000
DV Cassette Recorder



AJ-D610WA

2/3" IT 3CCD DVCPRO Camera/Recorder

DVCPRO
PV
series

The new AJ-D610WA camera/recorder features a high-sensitivity 2/3" IT 3-CCD that combines with DVCPRO's outstanding digital component system to assure superior recording quality.

The AJ-D610WA adds the convenience of accepting conventional 2/3" lenses. DVCPRO's compact 1/4" cassette lets this unit small in size, light in weight.

Also, AJ-D610WA boasts its low power consumption.

Suitable for a wide variety of applications, the high-performance AJ-D610WA is for today's video professionals.

High-Sensitivity and Low Smear

The IT-3CCD's 520,000 pixels assure outstanding picture quality, with full 750 lines of horizontal resolution. This new CCD boasts F11 (2,000-lux) sensitivity and, as dim as 0.5 lux. The smear level is extremely low for nighttime news gathering, where the contrasting problems of dim and bright lighting often pose difficulties.

16:9/4:3 Aspect Ratio Switchable

The AJ-D610WA's CCDs feature a light-receiving section that adapts to the wide 16:9 aspect ratio. The aspect ratio can be instantly switched between the conventional 4:3 and wide 16:9 modes.

Digital Creativity

The AJ-D610WA's digital circuitry has made possible a host of creative image-processing functions. Because corrections can be controlled numerically, you can create the exact pictures you want — another feature only digital processing offers.

"SUPER GAIN" Enables 0.5-Lux Shooting Illumination

The super gain button boosts gain by a full +30 or +36dB, for high-quality shooting even in dim lighting. This makes it possible to record subjects in lighting all the way down to 0.5 lux.

"SUPER IRIS" for One-Button Backlight

Pressing the Super Iris button adjusts the iris to provide correct exposure when a subject is backlit, such as when the subject moves from outside daytime light into a dark room.

Programmable Gain Selector

The programmable 3-position gain switch lets the operator select a low, medium or high gain. A total of 14 settings are available (-3, 0, +3, +6, +9, +12, +15, +18, +21, +24, +30 and +36dB), giving the operator outstanding control.

Additional Features

- Variable choice of optional viewfinder; standard 4:3 aspect ratio AJ-VF10P, high grade 4:3 aspect ratio AJ-VF15P, or high grade 16:9/4:3 switchable AJ-VF20WP



- One-touch camera status report
- One-touch rec review function
- Store set up file on PCMCIA SRAM CARD (SHL-064HSRVS)
- Built-in Gen-lock function
- Phantom power supply (48-VDC or 12V Phantom mic)
- Built-in monitor speaker
- One ND/CC filter wheel
- Picture Link function
- Compatible with the Anton/Bauer Trimpac Battery



Standard Accessories

- Shoulder strap
- Anton/Bauer Gold Mount Plate (Installed)
- Microphone
- Tripod Adaptor



AJ-D400

1/2" FIT 3CCD DVCPRO Camera/Recorder

DVCPRO
PV
series

The AJ-D400 camera/recorder combines DVCPRO quality and convenience with outstanding cost-performance. Its low-smear, low-noise 1/2" FIT-3CCD further enhances the many functions that make Panasonic camera/recorders the choice of broadcast stations all over the world.

The AJ-D400 lets you make detailed camera settings to create the level of imagery needed in professional use.

The VCR section features DVCPRO's digital component recording system to assure superior picture quality.

Ultra-Sensitive 1/2" 410,000-Pixel FIT 3CCD

The AJ-D400's 1/2" FIT CCD with on-chip lens boasts low smear, low flare and a high S/N ratio. This unit delivers picture quality that's well above most camera/recorders.

Digital Signal Processing Camera

Digital circuitry assures outstanding pictures and years of reliable use, regardless of temperature change and vibration. It also means simple operation, minimal maintenance, and easy camera set-up in the field.

DVCPRO: Reliable, High-Quality Recording

The AJ-D400's digital component recording system delivers superb images across a 5.75-MHz (Y) video bandwidth, and a video S/N ratio of 55 dB. Its error correction helps resist dropout, for greater quality and reliability.

The audio is excellent, too, thanks to the 2-channel PCM digital system with 48-kHz sampling and 16-bit recording.

Highly Detailed Camera Settings

The settings for the many digital image-processing functions are displayed by menu in the viewfinder for easy use.

- 2-D Low Pass Filter eliminates cross color.
- Dark Detail corrects details in dark areas.

- Chroma Detail improves resolution of bright colors.

- Matrix corrects 6 types of color phase.
- Super Color lets you emphasize 'highlight' colors.
- Black Stretch gives black areas greater emphasis.
- Other functions, such as gamma correction and auto knee, give the professional even more image-creating tools.

Accepts Wide Variety of 1/2" Lenses

The bayonet mount accommodates the many 1/2" lenses available today, and the easy-to-use AJ-D400 automatically adjusts the settings to match the lens.

Additional Features

- Light weight, low power consumption
- 66-minute recording with compact cassette
- 2-lux shooting illumination
- Programmable one-button super iris and super gain
- Synchro scan electronic shutter
- Shockless AWB control
- Backup VCR connector (26-pin) (Option)
- Standard SMPTE color bar output
- Built-in Gen-lock function
- Built-in SMPTE time code generator/reader
- Built-in monitor speaker
- Phantom power supply (48-VDC Phantom mic)
- Optional RET video input and time code input/output (AJ-YA710P)
- Compatible with the Anton/Bauer Trimpac Battery

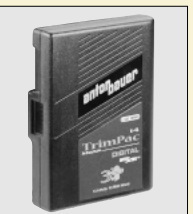

Standard Accessories

- 1.5" Electronic Viewfinder
- Microphone
- Tripod Adaptor
- Anton/Bauer Gold Mount Plate (Installed)



AJ-D215

1/3" IT 3CCD DVCPRO Camera/Recorder

DVCPRO
PV
series

The AJ-D215 uses the DVCPRO format, widely acclaimed for superior pictures, sound and reliability. This high cost-performance unit records up to 184 minutes on a single tape, making it ideal for shooting long events.

The AJ-D215 is equipped for convenience, too. A built-in ND filter that's controlled by a simple slide switch lets you continue shooting as you move indoors or out, and the optional DVCPRO Terminal interface (IEEE 1394) lets you connect to a DVCPRO VCR to back up your footage.



Up to 184 Minutes of Recording

The AJ-D215 records for up to 184 minutes on a single DVCPRO large cassette (AJ-5P92LP).^{*} This lets you shoot even long events without switching tapes, while enjoying a high level of reliability because DVCPRO's metal particle tape is renowned in the broadcasting industry for durability and stability.

^{*} For AJ-5P92LP cassette tapes, use a VCR supporting DVCPRO (25Mbps) 184 minutes tapes.

High-Density 1/3" IT 3-CCD

This 3-CCD unit, which assures superior resolution, high S/N ratio, high sensitivity and a wide dynamic range, helps deliver sharp images and true-to-life color.

2-Lux* Shooting Illumination

A CCD with on-chip lens and +18 dB gain-up lets you take quality shots in lighting as low as 2-lux*.

^{*}with T17 x 5BRM4 Lens

Built-in ND Filter

Turned on and off by a simple slide switch, this 1/16 ND filter assures stable pictures even in bright sunlight.

Auto White Balance — Preset/Memory/ATW

The AJ-D215 is preset with white balance settings for use indoors, outdoors, and under fluorescent lights. You can store additional settings in memory, and ATW is available.

Accepts 1/3" Lens

The AJ-D215 accepts most 1/3" bayonet lenses, and an optional adaptor allows use of many 1/2" lenses.

High-Resolution 1.5" EVF

The AJ-D215 has a large, 600-line B/W viewfinder. The unit is easy to adjust and accommodates operators who wear prescription eyeglasses.

DVCPRO Terminal (IEEE 1394) Interface Board (option)

The optional IEEE 1394 based DVCPRO terminal (AJ-YAD210) lets you connect to a back-up DVCPRO VCR for digital dubbing with superior picture and sound quality.

Additional Features

- Playback with no adaptor necessary
- One-touch camera status report
- Electronic shutter (1/100, 1/125, 1/250, 1/500, 1/1000, 1/2000, 1/4000, 1/8000-sec.)
- Easy setup, easy maintenance, digital signal processing
- Manual audio level
- Built-in SMPTE time-code generator/reader
- Compatible with the Anton/Bauer ProFormer Battery



Standard Accessories

- 1.5" Electronic Viewfinder
- Anton/Bauer Gold Mount Plate (Installed)

AJ-D450

DVCPRO Studio VCR

AJ-D440

DVCPRO Studio Player

DVCPRO
PV
series

Designed for professional use, the AJ-D450 editing VCR and AJ-D440 player offer impressive performance and low initial and running costs. The DVCPRO format assures accurate, high-quality editing and unmatched reliability. Both models offer a 9-pin remote terminal and analog interface for easy system configuration, and both can be adapted for SDI data transfer. Use of an extended-length DVCPRO tape allows up to 184 minutes of continuous operation, and DV tape playback ensures that existing tape libraries can be fully utilized.

Extra-Long, 184-Minute Recording/Playback

Both models can use the AJ-5P92LP extended-play tape to provide up to 184 minutes of continuous recording (AJ-D450) and playback (AJ-D450/AJ-D440). This allows the AJ-D450 to record extended programming onto a single tape cassette, for added convenience in production and transmission. For field recording, 66-minute M cassettes can also be used without the need for an adaptor.

DVCPRO Reliability

DVCPRO was developed primarily to provide the reliability needed in broadcasting. Its metal particle tape has been proven in professional use, and its original track pattern — with an 18-micron track pitch (twice that of DV formats) plus CTL and analog CUE tracks — assures top editing accuracy.

Outstanding Picture and Sound Quality

The AJ-D450/AJ-D440's digital component system delivers excellent pictures, with a video Y bandwidth of 5.5 MHz and video S/N ratio of 55 dB. The sound is superb, too, thanks to two 16-bit digital audio channels with 48-kHz sampling.

There's also one analog cue track. Use of the optional digital interface maintains high picture and sound quality even after editing and dubbing.

Playback of DV-Format Recordings

The AJ-D450/AJ-D440 can play back tapes recorded in DV, the consumer video format, using the optional AJ-CS750P cassette adaptor.^{*} This allows use of footage recorded on-scene by eyewitnesses using DV equipment.

^{*} The AJ-D450/AJ-D440 cannot record on DV cassettes even with the AJ-CS750P cassette adaptor.

^{*} The AJ-D450/AJ-D440 cannot play back DV cassette tapes recorded in LP mode, or long-time Mini-DV cassette tapes (SP mode 80 minutes/LP mode 120 minutes), even with the AJ-CS750P cassette adaptor.

Additional Features

- SMPTE/EBU time code recording/playback (VITC/LTC)
- Digital linear editing with ± 0 frame precision
- 60x shuttle search and jog functions
- Optional encoder remote controller (AU-ER65B)
- Condition monitor tracks tape error rate during playback
- RS-232C terminal enables computer control
- Easy on-screen set-up
- Compact 4U size



Rear View of AJ-D440 with optional AJ-YA655P and AJ-YA750P



Rear View of AJ-D450 with optional AJ-YA655P and AJ-YA750P

AJ-D250

DVCPRO Desktop Editing VCR

DVCPRO
PV
series

DVCPRO PV Series now welcomes a new addition: the AJ-D250 Desktop Editor.

The AJ-D250 provides insert and assemble editing through its RS-232C interface. This easy-to-carry unit combines a half-rack size and light weight — it measures only 8-7/16"(W) × 5-1/4"(H) × 15-3/8"(D) and weighs just 14.3 lbs. — with a host of outstanding features. The low-cost AJ-D250 is ideal for business use, schools, wedding videographers and other professional applications.

Simple Editing

Connecting the AJ-D250 to an AJ-A250 controller through the RS-232C interface lets you perform audio and video insert and assemble editing*. Preview function with AJ-A250 is also possible.

* With ±3-frame precision.

184-Minute Recording and Playback

The AJ-D250 provides up to 184 minutes of continuous recording and playback on an AJ-5P92LP extended-play tape cassette. This lets you record extended programming on a single tape — a big convenience in production and transmission. For use in the field, the AJ-D250 also records on DVCPRO M cassettes without the need for an adaptor.

Playback of DV-Format Recordings

The AJ-D250 makes DVCPRO recordings on durable metal-particle tape. Use of an optional AJ-CS750P cassette adaptor also allows the AJ-D250 to play back mini-DV cassettes.* The AJ-D250 can be combined with a DV Camera/Recorder to form an easy-to-use system at a very affordable cost.

* The AJ-D250 cannot record on Mini-DV cassettes, even with an adaptor. The AJ-D250 cannot play back Mini-DV cassettes recorded in LP mode.

Built-in Time Code Generator/Reader

The AJ-D250 has a built-in SMPTE time code generator and reader. Time code is recorded onto the sub-code area of each track, enabling to-the-frame precision and time code detection during searches. Precise indexing control is possible using a PC.

DVCPRO Interface (Optional)

The optional AJ-YAD250P board provides a DVCPRO interface for the AJ-D250, letting you digitally transfer video and audio signals that conform to IEEE1394 while maintaining the high precision and reliability needed in professional applications. For example, use the board to digitally dub between AJ-D250 and AJ-D250/D230H or back-up between the AJ-D250 and an AJ-D215. The AJ-YAD250 is also equipped with a 9-pin RS-232C interface terminal.

Optional 9-pin AJ-YA230HP Remote Interface and 9-pin Remote & TC IN/OUT AJ-YA250P Interface

Both AJ-YA230HP and AJ-YA250P interface board allow remote control of basic operations using a controller such as the Panasonic AJ-A95. This AJ-YA250P is equipped with TC IN/OUT interface with BNC × 2.

Optional AJ-A250 Controller

The AJ-A250 controller connects to the AJ-D250's RS-232C interface board and provides simple, intuitive "mark-in" and "mark-out" remote control. It also adds extra convenience with insert and assemble editing and jog-shuttle searches, and allows connection to a wide variety of S-VHS VCRs such as the Panasonic AG-5710, AG-5700, and DVCPRO desktop VCR AJ-D230H.

Additional Features

- Optional 9-pin AJ-YA230HP Remote Interface
- Optional 9-pin Remote & TC IN/OUT AJ-YA250P Interface
- Analog Interface
- On-Screen Setup Display
- Forward/Reverse Search at 10x normal speed (approx.)
- Input and output TBC
- Encoding on set-up menu
- Independent adjustment of audio input levels (CH1/CH2)
- 4-position audio output selector: CH1/CH2/CH3-4 (for DV cassette playback)
- Wired remote control (AG-A11P, optional)

AJ-D230H

DVCPRO Desktop VCR

AJ-D220

DVCPRO Office Viewer

DVCPRO
PV
series

The AJ-D230H is an affordably priced DVCPRO VCR that allows convenient desktop use. A built-in RS-232C interface, which comes as standard equipment, allows remote control from a personal computer for non-linear editing or multimedia production. The AJ-D230H is extremely compact — 8-3/8"(W) × 5-3/16"(H) × 15-3/8"(D) — and weighs only 15.4 lbs. Equipped with a carrying handle, this versatile digital VCR is ideal as backup equipment when shooting with a camera or for dubbing of viewing.

The AJ-D230H is ideal for dubbing and back-up recording. Connecting to a PC via an RS-232C terminal, it serves as a highly versatile multimedia VCR. The AJ-D220 player is a multipurpose viewer that you can use almost anywhere, with an RF terminal that allows playback on ordinary TV sets.

Compact and Easy to Carry, With Low Power Consumption

Measuring only 8-3/8"(W) × 5-3/16"(H) × 15-3/8"(D), the AJ-D230H and AJ-D220 fit easily on a desktop. Two of these units can be placed side by side in a standard 19" rack. Each is also light in weight — just 15.4 lbs. — and is equipped with a handle for easy carrying in one hand. Both feature low power consumption — 45W for AJ-D230H, only 37W for the AJ-D220.



Up to 184 Minutes of Recording/Playback

The AJ-D230H and AJ-D220 for both program production and broadcasting. They offer up to 184 minutes of recording or playback on a DVCPRO large cassette (AJ-5P92LP), and up to 66 minutes on a medium cassette (AJ-P66MP).

Playback of DV Format Recordings

The AJ-D230H and AJ-D220 can playback tapes recorded in DV, the consumer video format, using the optional AJ-CS750P cassette adaptor*. This allows easy use for news events recorded on DV-format equipment by eyewitnesses or others at the scene.

* The AJ-D230H cannot record on DV cassettes even with the AJ-CS750P cassette adaptor.

* The AJ-D230H and AJ-D220 cannot playback DV cassette tapes recorded in LP mode, or long-time Mini-DV cassette tapes (SP mode 80 minutes/LP mode 120 minutes), even with the AJ-CS750P cassette adaptor.

A Variety of Interface Gives the AJ-D230H Extra Versatility

The AJ-D230H comes standard with an RS-232C (25-pin) interface for remote control from a personal computer. By replacing this with the AJ-YAD230P option board, you can input and output IEEE1394-standard digital video/audio signals and 9-pin (RS-232C) terminal. Analog input and output terminals for video, S-Video and 2-channel audio also come as standard equipment.

The AJ-D220 Office Viewer

In addition to BNC, pin (RCA) and S-VIDEO (Y/C) video output, the AJ-D220 features RF modulated output that allows it to connect to virtually any TV set. It also comes standard with wireless remote control.

Additional Features

- Auto functions and repeat playback for convenient use in demonstrations.
- SMPTE/EBU time code recording/playback
- Forward/reverse search at about 10x normal speed
- 4-position audio output selector: CH1/CH2/CH3-4 (for Mini-DV cassette playback)
- Wired remote control (optional; AG-A11)
- RS-422A 9-pin remote control interface (optional, AJ-YA230HP) (AJ-D230H only)



Rear View with AJ-YAD250P DVCPRO interface board

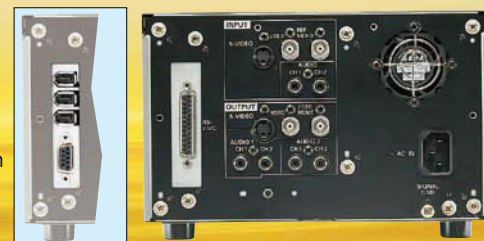

AJ-D220

AJ-D230H

Rear View with AJ-YAD230P IEEE 1394 DVCPRO interface board



Rear View of AJ-D230H

AG-EZ30U

3-CCD DV Camera/Recorder

This compact camera features 3-CCD that's suitable for professional use. The combination of convenient size and superior picture quality makes the AG-EZ30U ideal for the video journalist.



- High Picture quality with a 1/4" 3-CCD
- Records 60 full minutes of high-quality digital pictures and sound (2CH/4CH)
- Weighs only 1.52 lbs.; features a tough, durable inner mechanism
- Angle-adjustable 2.5" color LCD monitor and color viewfinder
- DV terminal (IEEE 1394) digital input/output
- 12x Optical/120x Super Digital Zoom with Digital Image Stabilizer
- 1/60 to 1/8000 sec. electronic shutter
- Manual focus and manual iris
- 5-Mode Program AE: Sports, Portrait, Spotlight, Surf & Snow and Low Light
- 5-Mode White Balance: Auto, Indoor (preset), Outdoor (preset), Set, Fluorescent
- Frame-by-frame recording of still images
- Scene search and blank search
- Wireless remote control
- Wide conversion lens supplied



Playback of Mini-DV Tapes on DVCPRO Equipment
Mini-DV cassettes can be played back in DVCPRO VCR using the optional AJ-CS750P adaptor*, allowing the use of Mini-DV tapes in broadcasts.

* DVCPRO VCR cannot record on Mini-DV tapes, even with the adaptor.

AG-DV2000

DV Cassette Recorder

The new AG-DV2000 DV-format VCR brings superior digital quality to more professionals. At the heart of the AG-DV2000 is a DVCPRO-based DV mechanism that assures high picture quality, quick response and outstanding reliability.

- Superb Pictures with DV Digital Recording Format
- 4-Channel PCM Sound Recording
- 3-Hour Recording Capability on a Single AY-DV123EB Cassette in LP Mode
- Aluminium Diecast Chassis for High Reliability/Durability
- Reel Drive Technology
- Laser Adjustment Technology
- Handy Wireless and Wired Editing Controller
- Manual and Programmed Editing
- DV Terminal (i.LINK)
- 5-pin Editing Terminal
- Complete Analog Input/Output
- Super Linear Slow Playback
- Memory Backup
- Pre-roll Editing
- Rehearsal Function
- Sound Search
- Program correction
- On-Screen Display
- Timing Control Function
- Frame-by-Frame Timecode
- 3-D Digital Y/C Separation
- Hue and Color Level Adjustment

* Audio dubbing is not possible in LP mode.

* Picture noise may appear during slow or frame advance playback, and the tape counter may not advance smoothly.

* Picture noise may appear when tapes recorded in LP mode are played on some VCRs.

• DV Tapes can be played back with DVCPRO VCR

* DV/Mini-DV tapes recorded in LP mode cannot be played in a DVCPRO VCR.



Mini **DV** Digital Video Cassette

Mini **DV** Digital Video Cassette **DV** Digital Video Cassette

AG-A850

Editing Controller



- 512-event editing memory
- 5 RS-422 (9-pin) remote terminals allow for connection with VCRs
- When 4 players and 1 recorder are connected, the AG-A850 allows control of 2 players as source machines.
- When 2 players and 3 recorders are connected, all 3 recorders can be controlled producing three tapes at once.
- 2 Jog/Shuttle dials and 10-key pads increase editing efficiency
- GPI ports for connection and control of external AV source
- Monitor display (output)
- Simple mode setting
- A/B roll editing using two video tape players
- 4-channel audio editing
- High-precision editing (± 0 frame with TC)
- Color frame editing
- Audio split editing
- Slow-motion editing using VCRs with AT (auto-tracking) on Digital Slow
- Auto Tag function for easy Multi-Event editing

AJ-A250

Editing Controller



- 25-pin (RS-232C) serial remote for variable editing
- Compact size
- Simple and easy operation
- Insert/Assemble editing capability
- The large Jog/Shuttle dial on the control panel allows easy playback speed control
- AC adaptor (supplied)

DVCPRO Cassette Tapes

1/4" Digital Video Cassette Tapes



DVCPRO Video Cassettes Line-Up

Model No.	Recording/Playback Time	Length
AJ-5P92LP	184 min.	377 m
AJ-P126LP	126 min.	259 m
AJ-P94LP	94 min.	194 m
AJ-P66LP	66 min.	137 m
AJ-P34LP	34 min.	72 m
AJ-P66MP	66 min.	137 m
AJ-P46MP	46 min.	96 m
AJ-P33MP	33 min.	70 m
AJ-P24MP	24 min.	51 m
AJ-P12MP	12 min.	27 m
AJ-CL12LP	Cleaning Tape (12 min, 27 m)	
AJ-CL12MP	Cleaning Tape (12 min, 27 m)	











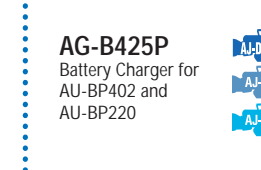

DVCPRO Cleaning Tape

OPTIONAL ACCESSORIES

LENSES

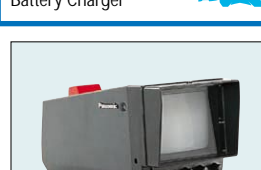
 A19 × 8.7BERM4 2/3" × 19 Fujinon Lens with Extender	 A19 × 8.7BRM4 2/3" × 19 Fujinon Lens	 YJ18 × 9B4IRS 2/3" × 19 Canon Lens with Extender	 YJ18 × 9B4KRS 2/3" × 19 Canon Lens	 S14 × 7.5BRM4 1/2" Bayonet Type Fujinon Lens
 YH14 × 7.3KRS 1/2" Bayonet Type Canon Lens	 S19 × 6.5BRM4 S17 × 6.6BRM4 1/2" Bayonet Type Fujinon Lens	 S19 × 6.5BERM4 1/2" Bayonet Type Fujinon Lens with 2 × Extender	 T17 × 5BRM4 T14 × 5.5BRM4 T12 × 3.8BRM4 1/3" Bayonet Type Fujinon Lens	 ACM-12B Lens Adaptor for 1/2" Fujinon Lens WCV-65 Wide Converter for T14 × 5.5BRM4 Fujinon Lens

BATTERIES

• Anton/Bauer		• Panasonic	
 Hytron50 Battery Pack	 Digital Trimpac/Trimpac Battery Pack	 Proformer Battery Battery Pack	 AG-B425P Battery Charger for AU-BP402 and AU-BP220
 ABC-800H Anton/Bauer Battery Charger	 ABUL2S Anton/Bauer Ultra Light	 AU-BP220-PA Battery Pack	 AU-BP402-P Battery Pack
 AJ-MH700P Microphone Kit	 AG-MH800P Microphone Holder	 SHAN-TM700 Tripod Adaptor	 AQ-EC1 Extension Control Unit

† Standard accessory for AJ-D610WA and AJ-D400. †

* Some options are not available in certain areas.

OPTIONAL ACCESSORIES

 AJ-HT900 Hard Carrying Case	 AJ-SC900* Soft Carrying Case	 SHAN-RC700* Rain Cover	 AJ-YAD210P IEEE1394 DVCPRO Terminal	 AJ-YA710P Return Video In and TC In/Out Connector
 AJ-YA700P 26-pin VCR Connector	 SHAN-C12TCA TC/Audio Cable	 AJ-MA75P Rack Mount Adaptor (Black)	 AJ-YA655P AES/EBU Digital Interface Board (BNC)	 AG-A350* Editing Controller
 AJ-YA900P 26-pin VCR Multi Connector	 AJ-MA34HP Rack Mount Adaptor (Ivory)	 AJ-YA656P AES/EBU Digital Interface Board (XLR)	 AJ-YA750P Component Digital Serial Interface Board	 AJ-YA250P 9-pin Remote & TC IN/OUT
 AG-A11P Wired Remote Control Unit	 AJ-YAD250P DVCPRO Interface Board	 AU-C5P/AU-C10P 5 m/10 m 9-pin Remote Cable	 AU-ER65B* Encoder Remote Controller	
 AJ-YA230HP 9-pin Remote Control Interface Board	 AJ-CS750P Mini-DV Cassette Adaptor	 AJ-DTC2P/AJ-DTC4P DVCPRO Terminal Cable		

VIEWFINDER OPTION

 AJ-VF20WP Viewfinder High grade 16:9/4:3 aspect ratio switchable	 AJ-VF15P Viewfinder High grade 4:3 aspect ratio	 AJ-VF10P Viewfinder Standard 4:3 aspect ratio
--	---	---

 AG-BP25P Battery Pack	 AG-CB50P Car Battery Charger/Adaptor with DC Cable	 AG-B51P AC Adaptor with AC Cord and DC Power Cable	 AY-DVM63EB AY-DVM33EB Mini-DV Cassette Tape
	 AY-DV123EB DV Cassette Tape		 AY-DVMCLC Cleaning Tape

* Some options are not available in certain areas.

■ A/B Roll Editing System using AG-A850 Editing Controller

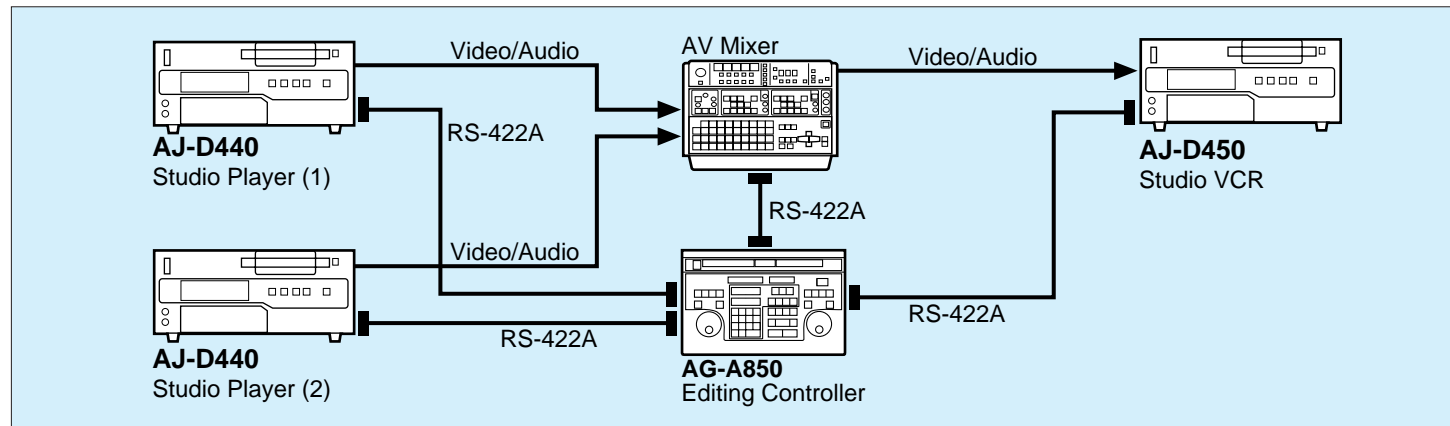

■ Editing System (Digital)

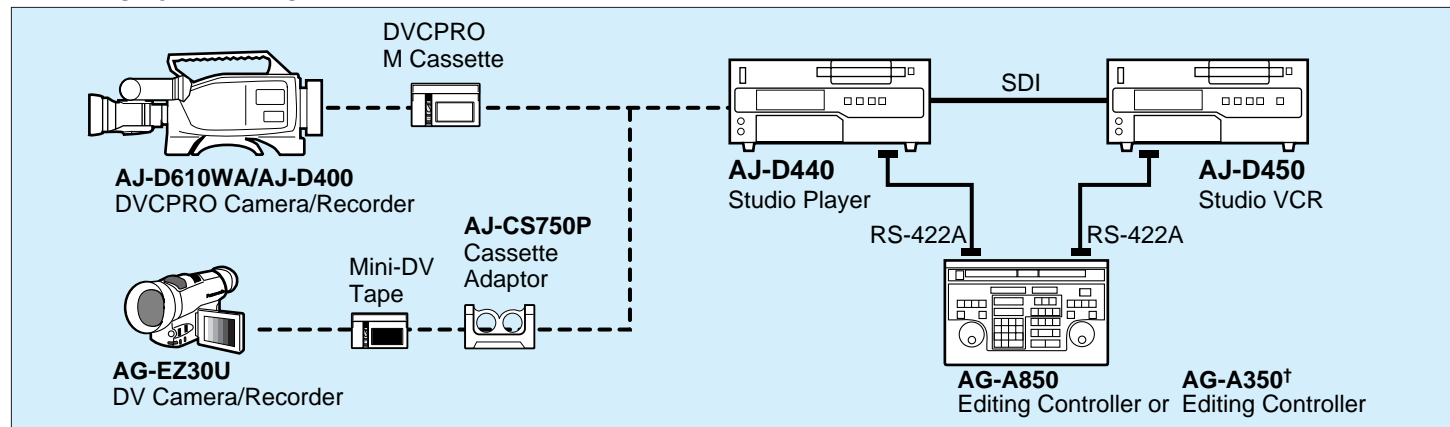

■ AJ-D250 Simple Editing

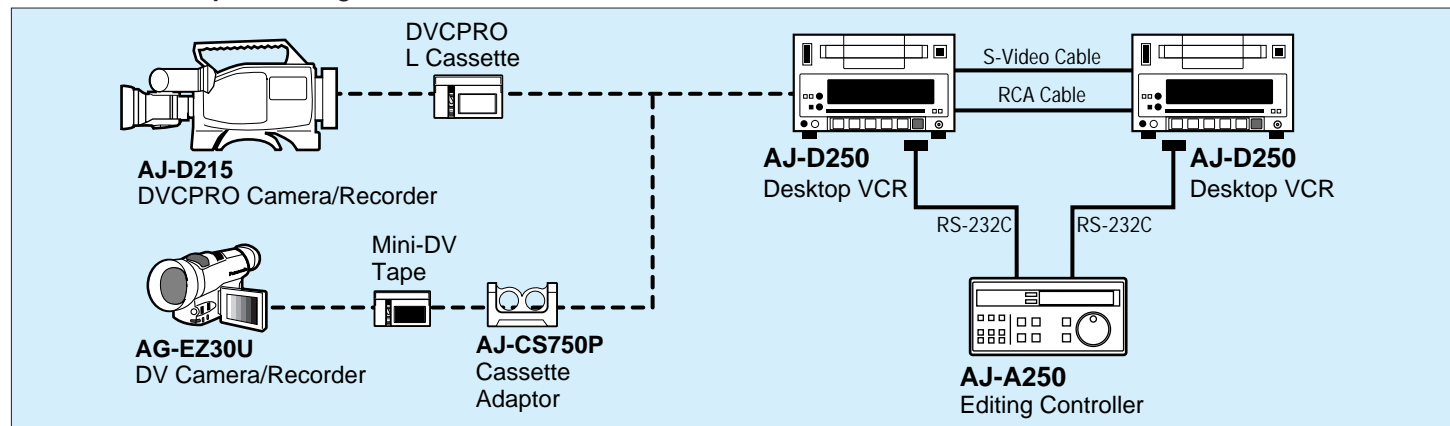

■ AJ-D250 Editing System from DVCPRO to S-VHS

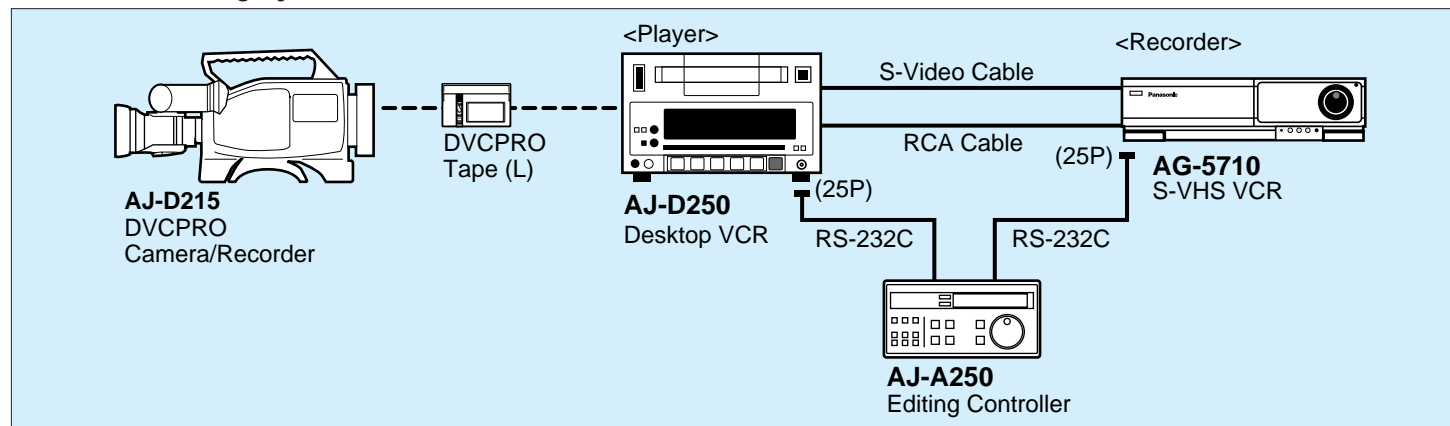

■ AJ-D250/AJ-D230H Loading Images to a PC

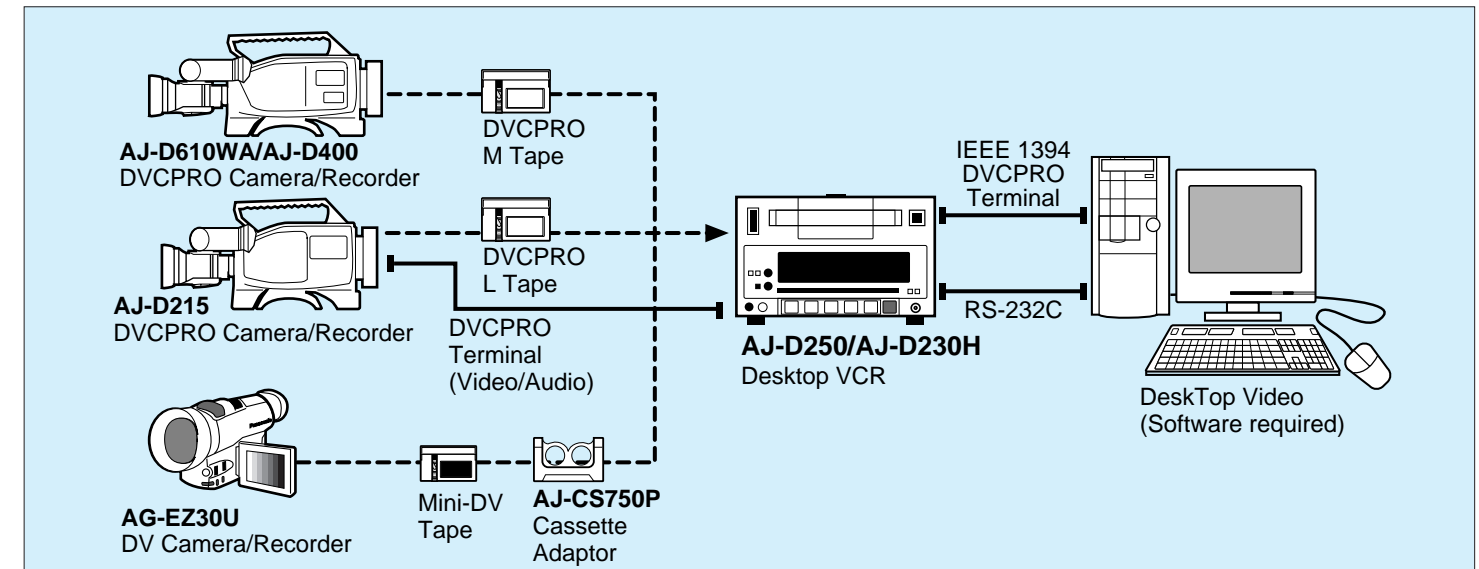

■ AG-DV2000 DV Editing System

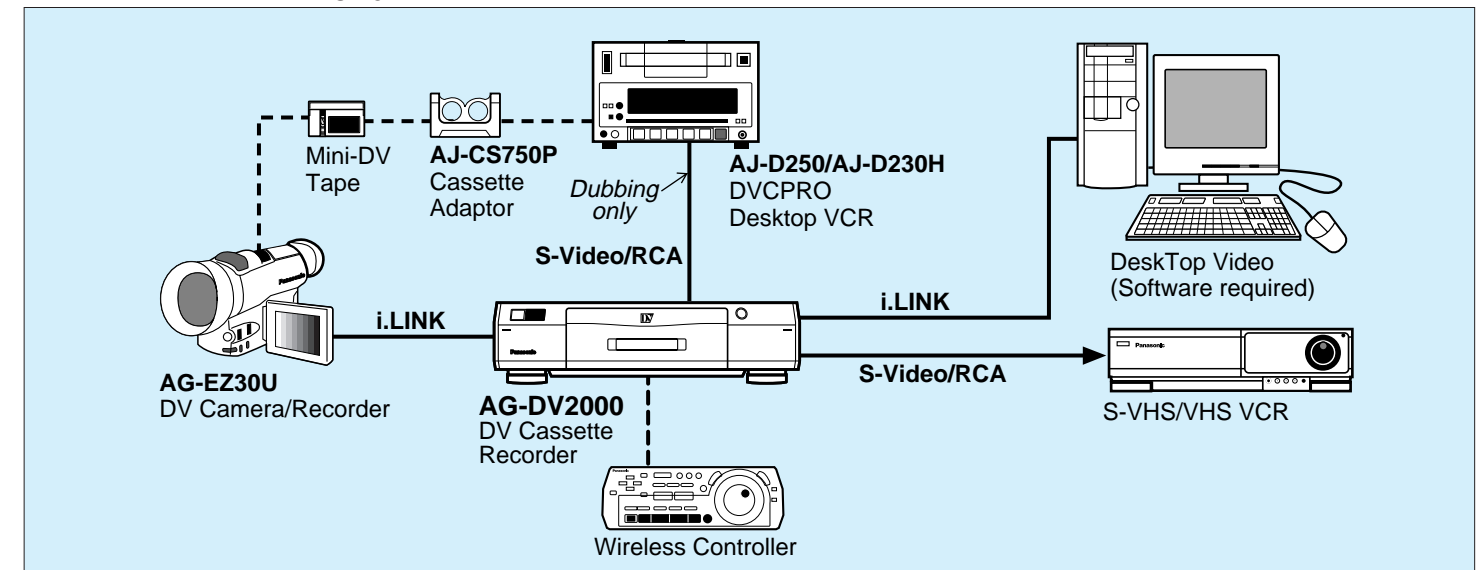

■ AJ-D250/AJ-D230H Digital Dubbing System

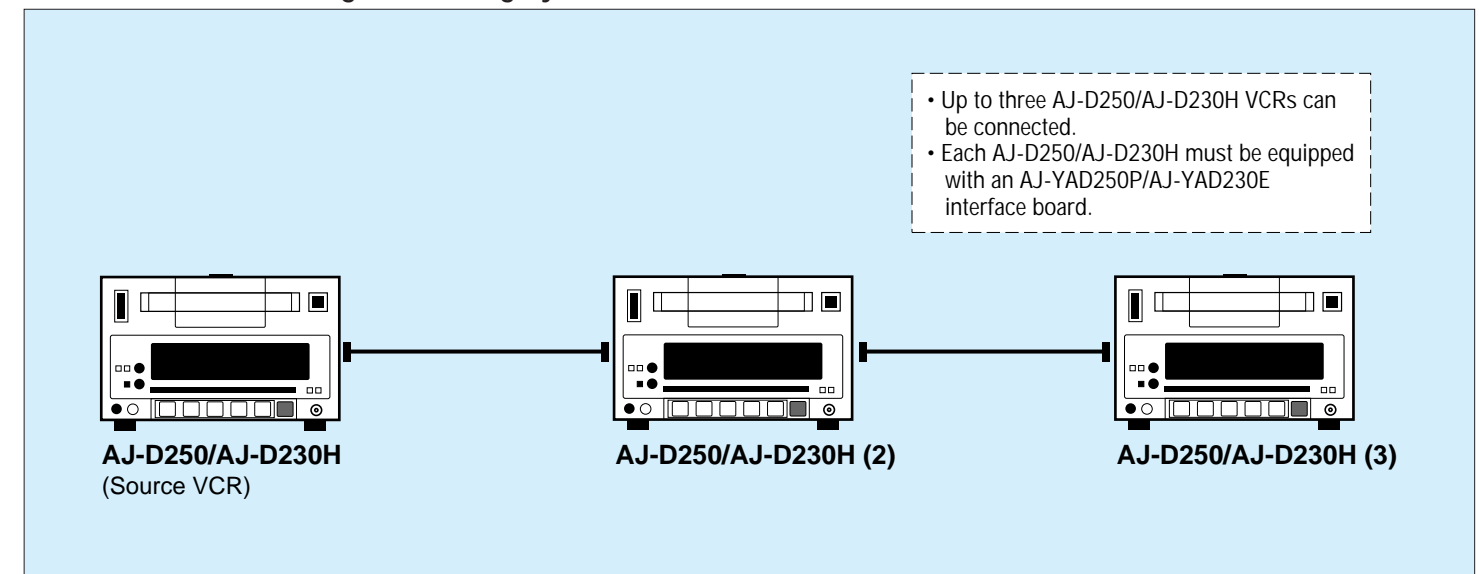

AJ-D610WA (tentative)

AJ-D400

AJ-D215

GENERAL	Power Requirement:	DC12V (11V to 17V)	DC12V (11V to 17V)	DC12V (10.5V to 17V)	
	Battery:	Anton/Bauer, NP-1, BP-90, AU-BP402, AU-BP220	Anton/Bauer, NP-1, BP-90, AU-BP402, AU-BP220	Anton/Bauer, NP-1, BP-90, AU-BP402, AU-BP220	
	DC In:	XLR 4-pin (Male)	XLR 4-pin (Male)	XLR 4-pin (Male)	
	Power Consumption:	24W	23W	Less than 16W (including 1.5" viewfinder)	
	Operating Temperature:	32°F to 104°F (0°C to 40°C)	32°F to 104°F (0°C to 40°C)	32°F to 104°F (0°C to 40°C)	
	Storage Temperature:	4°F to 140°F (-20°C to 60°C)	4°F to 140°F (-20°C to 60°C)	4°F to 140°F (-20°C to 60°C)	
	Operating Humidity:	Less than 85%	Less than 85%	Less than 80%	
	Weight:	About 9.03 lbs. (4.1 kg) About 14.55 lbs. (6.6 kg) in full-operation	12.87 lbs. (5.85 kg)* (*varies according to the equipment composition) (Including lens, viewfinder, tape, and battery pack)	13.0 lbs. (5.9 kg)* (*varies according to the equipment composition) (Including lens, viewfinder, tape, and battery pack)	
	CAMERA SECTION	Pick-up Device:	Interline Transfer 2/3" CCD Image Sensor (×3)	Frame Interline Transfer 1/2" CCD Image Sensor (×3)	Interline Transfer 1/3" CCD Image Sensor with On-Chip Lens (×3)
	Camera	Picture Element:	520,000-pixel	410,000-pixel	—
Digital Quantization:		10 bits A/D	10 bits A/D	8 bits A/D	
Digital Signal Processing:		14.4 MHz/28.8 MHz	14.3 MHz/28.6 MHz	13.5 MHz/27 MHz	
Sensitivity:		2000 lux with F11.0	2000 lux with F8.0	2000 lux with F5.6 ±1/2, 3200K	
Minimum Illumination:		0.5 lux at F1.4, +36dB gain	2 lux (F1.4, +30dB gain)	5 lux (F1.4, +18dB gain) (2 lux with T17×5BRM4)	
Shutter Speed:		1/60, 1/120, 1/250, 1/500, 1/1000, 1/2000-sec.	1/100, 1/120, 1/250, 1/500, 1/1000, 1/2000-sec.	1/100 to 1/8000-sec.	
Synchro Scan:		1/60.8 to 1/250-sec.	1/30.4 to 1/57.4-sec., 1/61.7 to 1/250-sec. (variable)	—	
Optical Filter:		3200K, 5600K + 1/8ND, 5600K, 5600K + 1/64ND	3200K, 5600K + 1/4ND, 5600K, 5600K + 1/16ND	1/16-ND Filter, Manual On/Off by slide switch	
S/N Ratio:		62dB (typical)	62dB (typical)	60dB (typical)	
Horizontal Resolution:		750 TV lines (Center)	750 TV lines (Center)	500 TV lines (Center)	
Vertical Resolution:	450 TV lines/500 TV lines (Super-V)	450 TV lines/500 TV lines (Super-V)	400 TV lines		
Registration Error:	Less than 0.03% (all zones, without lens)	Less than 0.03% (all zones, without lens)	Less than 0.03% (all zones, without lens)		
Gain:	-3/0/+3/+6/+9/+12/+15/+18/+21/+24/+30dB, Super Gain: +30/+36dB	-3/0/+3/+6/+9/+12/+15/+18/+21/+24/+30dB	0/+6/+12dB, 0/+9/+18dB		
Optical System:	F1.4 prism system	F1.4 prism system	F1.4 prism system		
Lens Mount:	2/3" bayonet mount	1/2" bayonet mount	1/3" bayonet mount		
Viewfinder	CRT:	—	1.5" monochrome	1.5" monochrome	
	Horizontal Resolution:	—	600 TV lines (Center)	600 TV lines (Center)	
	Control:	—	VR: Bright, Contrast, Peaking, SW: Tally, Zebra, Character	VR: Bright, Contrast, Peaking, SW: Tally, Zebra, Character	
VCR SECTION	Format:	DVCPRO 1/4" Digital compressed recording	DVCPRO 1/4" Digital compressed recording	DVCPRO 1/4" Digital compressed recording	
	General	Recording Track:	Digital Video Digital Audio: 2CH CUE: 1 Track Sub-Code CTL: 1 Track	Digital Video Digital Audio: 2CH CUE: 1 Track Sub-Code CTL: 1 Track	Digital Video Digital Audio: 2CH Sub-Code CTL: 1 Track
		Tape Speed:	33.820 mm/s	33.820 mm/s	33.820 mm/s
		Tape:	1/4-inch Metal Particle Tape	1/4-inch Metal Particle Tape	1/4-inch Metal Particle Tape
		Cassette Size:	AJ-P66MP: 97.5 x 64.5 x 14.6 mm	AJ-P66MP: 97.5 x 64.5 x 14.6 mm	AJ-5P92LP: 125 x 78 x 14.6 mm
	Recording/Playback Time:	66 min. with AJ-P66MP cassette	66 min. with AJ-P66MP cassette	184 min. with AJ-5P92LP cassette	
	FF/REW Time:	Approx. 3 min. using AJ-P66MP cassette	Approx. 3 min. using AJ-P66MP cassette	Approx. 8 min. using AJ-5P92LP cassette	
	Video	Sampling Frequency:	Y: 13.5 MHz, C (PB/PR): 3.375 MHz	Y: 13.5 MHz, C (PB/PR): 3.375 MHz	Y: 13.5 MHz, C (PB/PR): 3.375 MHz
		Quantization:	8 bits/sample	8 bits/sample	8 bits/sample
		Error Correction:	Reed-Solomon Code	Reed-Solomon Code	Reed-Solomon Code
Bandwidth:		Y: 30Hz to 5.75 MHz +1.0/-3.0dB	Y: 30Hz to 5.75 MHz +1.0/-3.0dB	Y: 0 to 5.75MHz, +1.0/-3.0dB	
S/N Ratio:		55dB	55dB	55dB	
K Factor (2T):		2% or less	2% or less	—	
Y/C Delay:		30 ns or less	30 ns or less	20 ns or less	
Audio		Sampling Frequency:	48kHz	48kHz	48kHz
		Quantization:	16 bits/sample	16 bits/sample	16 bits/sample
		Frequency Response:	20Hz to 20kHz, +1.0dB/-1.0dB	20Hz to 20kHz, +1.0dB/-1.0dB	20Hz to 20kHz, +1.0dB/-1.5dB
	Dynamic Range:	More than 80dB (at 1kHz, AWTD)	More than 80dB (at 1kHz, AWTD)	—	
	Distortion:	Less than 0.1% (at 1kHz, reference level)	Less than 0.1% (at 1kHz, reference level)	Less than 0.2% (at 1kHz, reference level)	
	Crosstalk:	—	—	Less than -65dB (at 1kHz, between 2 channels)	
	Wow & Flutter:	Below measurable limit	Below measurable limit	Below measurable limit	
	Headroom:	20dB	20dB	20dB	
	Emphasis:	T1=50µs T2=15µs (ON/OFF Selectable)	T1=50µs T2=15µs (ON/OFF Selectable)	—	
	Signal Inputs	Genlock In:	BNC × 1, 1.0Vp-p, 75	BNC × 1, 1.0Vp-p, 75	—
Mic In:		XLR 3-pin, balanced, -60dBu, 3k Ω , -60/-50/-40dBu selectable	XLR 3-pin, balanced, -60dBu, 3k Ω , -60/-50/-40dBu selectable	XLR 3-pin, balanced, -60dBu, 3k Ω , -60/-50/-40dBu selectable	
Audio In (CH1/CH2):		XLR (CH1/CH2), balanced, 10k MIC/LINE Switchable MIC: -60/-50/-40dBu selectable, 10k LINE: -60/+4dBu selectable, 10k	XLR (CH1/CH2), balanced, 10k MIC/LINE Switchable MIC: -60/-50/-40dBu selectable, 10k LINE: -60/+4dBu selectable, 10k	MIC/LINE Switchable with internal DIP SW MIC: -60/-50/-40dBu selectable, 10k LINE: -60/+4dBu selectable, 10k	
Time Code In (option):		BNC × 1, 0.5 to 18Vp-p, 10k	0.5 to 18Vp-p, high impedance	—	
Camera Out:		BNC × 1, 1.0Vp-p, 75	BNC × 1, 1.0Vp-p, 75	—	
Video Out:		BNC × 1, 1.0Vp-p, 75	BNC × 1, 1.0Vp-p, 75	BNC × 1, 1.0Vp-p, 75	
S-VIDEO Out:		—	—	4-pin × 1, Y: 1.0Vp-p, 75 Ω , C: 0.286Vp-p, 75	
Audio Out (CH1/CH2):		XLR (CH1/CH2/MIX selectable) +4dBu balanced, low impedance	XLR (CH1/CH2/MIX selectable) +4dBu balanced, low impedance 12-pin Multi-connector, (optional AJ-YA900P) CH1/CH2, -20dBu unbalanced, low impedance	RCA (CH1/CH2), -6dBu unbalanced, low impedance	
Headphones:		Stereo mini jack	Stereo mini jack	Stereo mini jack	
Time Code Out (option):		BNC × 1, 1.5Vp-p, low impedance	BNC × 1, 1.5Vp-p, low impedance	—	
Others	DVCPRO I/F Out:	—	—	IEEE1394 Standards (6-pin)	
	RET Video In (option):	BNC × 1, 1.0Vp-p, 75	BNC × 1, 1.0Vp-p, 75	—	
	26-pin VCR connector (option):	Component video, 75	Component video, 75	—	
	ECU:	6-pin, Camera Remote	6-pin, Camera Remote	—	
	Lens:	12-pin	12-pin	12-pin	
	DC OUT:	4-pin DC 12V, Max. 0.1A	4-pin DC 12V, Max. 0.1A	—	
	DC IN:	XLR 4-pin (DC 11 to 17V)	XLR 4-pin (DC 11 to 17V)	XLR 4-pin (DC 12V)	

AJ-D450

AJ-D440

GENERAL	Power Requirement:	AC120V ±10%, 50 to 60Hz	AC120V ±10%, 50 to 60Hz
	Power Consumption:	150W	120W
	Format:	DVCPRO Format 1/4" Digital compressed recording	DVCPRO Format 1/4" Digital compressed recording
	Recording Track:	Digital Video, Digital Audio: 2CH TC: REC in Sub-Code area, Cue: 1 Track, CTL: 1 Track	Digital Video, Digital Audio: 2CH TC: REC in Sub-Code area, Cue: 1 Track, CTL: 1 Track
	Tape Speed:	33.820 mm/s	33.820 mm/s
	Tape:	1/4-inch Metal Particle Tape	1/4-inch Metal Particle Tape
	Cassette Size:	AJ-5P92LP: 125 x 78 x 14.6 mm, AJ-P66MP: 97.5 x 64.5 x 14.6 mm	AJ-5P92LP: 125 x 78 x 14.6 mm, AJ-P66MP: 97.5 x 64.5 x 14.6 mm
	Recording/Playback Time:	Max. 184 min. with AJ-5P92LP, Max. 66 min. with AJ-P66MP	Max. 184 min. with AJ-5P92LP, Max. 66 min. with AJ-P66MP
	FF/REW Time:	Within 3.5 min. using AJ-5P92LP, Within 2 min. using AJ-P66MP	Within 3.5 min. using AJ-5P92LP, Within 2 min. using AJ-P66MP
	Editing Accuracy:	±0 frame (with TC)	—
Tape Timer Accuracy:	±1 frame (continuous CTL signal use)	—	
Operating Temperature:	41°F to 104°F (5°C to 40°C)	41°F to 104°F (5°C to 40°C)	
Operating Humidity:	10% to 90% (Non DEW)	10% to 90% (Non DEW)	
Search Speed:	0 to ±60 (in color)	0 to ±60 (in color)	
Weight:	35.1 lbs. (15.9 kg)	33.1 lbs. (15.0 kg)	
Dimensions:	16-11/16" x 6-7/8" x 16-3/8" (424 x 175 x 415 mm)	16-11/16" x 6-7/8" x 16-3/8" (424 x 175 x 415 mm)	
VIDEO	Sampling Frequency:	Y: 13.5MHz C (PB/PR): 3.375MHz	Y: 13.5MHz C (PB/PR): 3.375MHz
	Quantization:	8 bits/sample	8 bits/sample
	Bandwidth:	Y: 25Hz to 5.5MHz (+1.0/-1.5dB) PB/PR: 25Hz to 1MHz (+1.0/-2.0dB)	Y: 25Hz to 5.5MHz (+1.0/-1.5dB) PB/PR: 25Hz to 1MHz (+1.0/-2.0dB)
	S/N Ratio:	55dB Typ.	55dB Typ.
	K Factor:	2% or less	2% or less
AUDIO	Sampling Frequency:	48kHz	48kHz
	Quantization:	16 bits/sample	16 bits/sample
	Frequency Response:	20Hz to 20kHz (±1.0dB)	20Hz to 20kHz (±1.0dB)
	Crosstalk:	Less than -80dB (at 1kHz, between any 2 channels)	Less than -80dB (at 1kHz, between any 2 channels)
	Dynamic Range:	More than 85dB (at 1kHz, emphasis off, "A" WTD)	More than 85dB (at 1kHz, emphasis off, "A" WTD)
	Wow & Flutter:	Below measurable limit	Below measurable limit
	Headroom:	18dB	18dB
	Emphasis:	T1=50µsec/T2=15µsec (On/Off automatic)	T1=50µsec/T2=15µsec (On/Off automatic)
	Video Gain:	±3dB*	±3dB*
	Chroma Gain:	±3dB*	±3dB*
Chroma Phase:	±30°*	±30°*	
Black Level:	±100mV*	±100mV*	
Sync Phase:	±2µsec*	±2µsec*	
SC Phase:	±180°	±180°	
		*Only with external encoder remote controller.	*Only with external encoder remote controller.
VIDEO INPUT SIGNAL	Analog Component:	BNC × 3 (Y, PB, PR), Y: 1.0Vp-p, 75 Ω , PB/PR: 0.7Vp-p, 75 Ω (100% Color Bar)	—
	Analog Y/C:	S-VIDEO (4P) × 1, Y: 1.0Vp-p, 75 Ω , C: 0.3Vp-p, 75 Ω (Burst)	—
	Analog Composite:	BNC × 2, loop-through with 75 Ω On/Off	—
	Reference:	Analog Composite, BNC × 2, loop-through with 75 Ω On/Off	—
	Serial Digital Component:	BNC × 2, active throughout, EBU Tech.3267-E (Option)	—
VIDEO OUTPUT SIGNAL	Analog Component:	BNC × 3 (Y, PB, PR), Y: 1.0Vp-p, 75 Ω , PB/PR: 0.7Vp-p, 75 Ω (100% Color Bar)	BNC × 3 (Y, PB, PR), Y: 1.0Vp-p, 75 Ω , PB/PR: 0.7Vp-p, 75 Ω (100% Color Bar)
	Analog Y/C:	S-VIDEO (4P) × 1, Y: 1.0Vp-p, 75 Ω , C: 0.3Vp-p, 75 Ω (Burst)	S-VIDEO (4P) × 1, Y: 1.0Vp-p, 75 Ω , C: 0.3Vp-p, 75 Ω (Burst)
	Analog Composite:	BNC × 3, 1.0Vp-p, 75 Ω VIDEO1, VIDEO2, VIDEO3 (Superimpose On/Off)	BNC × 3, 1.0Vp-p, 75 Ω VIDEO1, VIDEO2, VIDEO3 (Superimpose On/Off)
	Serial Digital Component:	BNC × 3, EBU Tech.3267-E (Option)	BNC × 3, EBU Tech.3267-E (Option)
AUDIO INPUT SIGNAL	Analog (CH1, CH2):	XLR × 2, 600 Ω high impedance selectable +4/0/-20/-60dBu	—
	Digital (CH1/2) (Option):	BNC × 1 with AJ-YA655P, XLR × 1 with AJ-YA656P	—
	SDI Interface (Option):	BNC × 2 active throughout, 75 Ω (Video and Audio), EBU Tech.3267-E	—
AUDIO OUTPUT SIGNAL	Analog (CH1, CH2):	XLR × 2, Low impedance, +4/0/-20/-60dBu	XLR × 2, Low impedance, +4/0/-20/-60dBu
	Digital (CH1/2) (Option):	BNC × 1 with AJ-YA655P, XLR × 1 with AJ-YA656P	BNC × 1 with AJ-YA655P, XLR × 1 with AJ-YA656P
	SDI Interface (Option):	BNC × 3 (Video and Audio), 75 Ω EBU Tech.3267-E	BNC × 3 (Video and Audio), 75 Ω EBU Tech.3267-E
	Monitor:	RCA × 1, 600 Ω , -8dBV	RCA × 1, 600 Ω , -8dBV
	Headphone:	Variable level control, M6, 8	Variable level control, M6, 8
OTHERS	Time Code Input:	BNC × 1, 0.5 to 8.0Vp-p	—
	Time Code Output:	BNC × 1, 2.0Vp-p	BNC × 1, 2.0Vp-p
	Remote In:	D-sub 9-pin, RS-422A interface	D-sub 9-pin, RS-422A interface
	RS-232C:	D-sub 25-pin, RS-232C interface	D-sub 25-pin, RS-232C interface
	Encoder Remote In:	D-sub 15-pin	D-sub 15-pin
	Wired Remote:	—	—
Standard Accessory:	AC power code × 1	AC power code × 1	

AJ-D250

GENERAL	Power Requirement:	AC120V ±10%, 50 to 60Hz	
	Power Consumption:	56W	45W 37W
	Format:	DVCPRO Format 1/4" Digital compressed recording	
	Recording Track:	Digital Video, Digital Audio: 2CH TC: REC in Sub-Code area, Cue: 1 Track, CTL: 1 Track	
	Tape Speed:	33.820 mm/s	
	Tape:	1/4-inch Metal Particle Tape	
	Cassette Size:	AJ-5P92LP: 125 × 78 × 14.6 mm, AJ-P66MP: 97.5 × 64.5 × 14.6 mm	
	Recording/Playback Time:	Max. 184 min. with AJ-5P92LP, Max. 66 min. with AJ-P66MP	
	FF/REW Time:	Within 5 min. using AJ-5P92LP	
	Operating Temperature:	41°F to 104°F (5°C to 40°C)	
Operating Humidity:	Less than 80%		
Weight:	14.3 lbs. (6.5 kg)		
Dimensions:	8-7/16" × 5-1/4" × 15-3/8" (214 × 132 × 391 mm)		
VIDEO	Sampling Frequency:	Y: 13.5MHz C (PB/PR): 3.375MHz	
	Quantization:	8 bits/sample	
	Bandwidth:	30Hz to 4.5MHz (0 ±1dB)	
	Y/C Delay:	Less than 20 ns	
	K Factor:	Less than 2%	
	Sampling Frequency:	48kHz	
	Quantization:	16 bits/sample	
	Frequency Response:	20Hz to 20kHz (+1.0, -2.0dB)	
	Crosstalk:	Less than -80dB (at 1kHz, between 2 channels)	
	Dynamic Range:	More than 85dB (at 1kHz, emphasis off, "A" WTD)	
AUDIO	Wow & Flutter:	Below measurable limit	
	Headroom:	20dB	
	Analog Y/C:	S-VIDEO (4P) × 1, Y: 1.0Vp-p, 75 , C 0.286Vp-p, 75 (Burst)	
	Analog Composite:	BNC × 1, 1.0Vp-p, 75	
	Ref Video In:	BNC × 1, 1.0Vp-p, 75	
	Sync In:	BNC × 1, 1.0VP-P, 75 (Black Burst)	
	Analog Y/C:	S-VIDEO (4P) × 1, Y: 1.0Vp-p, 75 , C: 0.286Vp-p, 75 (Burst)	
	Analog Composite:	BNC × 1, 1.0Vp-p, 75	
	Monitor:	BNC × 1 (Superimpose on/off)	
	Phono Pin (Superimpose on/off):	Phono Pin (Superimpose on/off)	
AUDIO INPUT SIGNAL	Analog (CH1, CH2):	RCA × 2 (CH1/CH2), -8dBv, 47k	
	Analog (CH1, CH2):	RCA × 4 (CH1/CH2), -8dBv, 1k (Switchable to CH3, CH4 output, with DV tape playback)	
AUDIO OUTPUT SIGNAL	Headphone:	Variable level control, M3, 8	
	Headphone:	Variable level control, M3, 8	
OTHERS	Remote In:	D-sub 9-pin, RS-422A interface (option)	
	RS-232C:	D-sub 25-pin, RS-232C interface	
	Wired Remote:	For AG-A11 wired remote control (option)	
	Standard Accessory:	AC power code × 1	

AJ-D230H/AJ-D220

GENERAL	Power Requirement:	AC120V ±10%, 50 to 60Hz	
	Power Consumption:	45W	37W
	Format:	DVCPRO Format 1/4" Digital compressed recording	
	Recording Track:	Digital Video, Digital Audio: 2CH TC: REC in Sub-Code area, Cue: 1 Track, CTL: 1 Track	
	Tape Speed:	33.820 mm/s	
	Tape:	1/4-inch Metal Particle Tape	
	Cassette Size:	AJ-5P92LP: 125 × 78 × 14.6 mm, AJ-P66MP: 97.5 × 64.5 × 14.6 mm	
	Recording/Playback Time:	Max. 184 min. with AJ-5P92LP, Max. 66 min. with AJ-P66MP	
	FF/REW Time:	Within 3.5 min. using AJ-5P92LP	
	Operating Temperature:	41°F to 104°F (5°C to 40°C)	
Operating Humidity:	35% to 80% (non DEW)		
Weight:	15.4 lbs. (7.0 kg)		
Dimensions:	8-7/16" × 5-1/4" × 15-3/8" (214 × 132 × 391 mm)		
VIDEO	Sampling Frequency:	Y: 13.5MHz C (PB/PR): 3.375MHz	
	Quantization:	8 bits/sample	
	Bandwidth:	30Hz to 5.5MHz (+0/-3dB)	
	Y/C Delay:	—	
	K Factor:	3% or less	
	Sampling Frequency:	48kHz	
	Quantization:	16 bits/sample	
	Frequency Response:	20Hz to 20kHz (-1, +1.0, -2.0dB)	
	Crosstalk:	Less than -80dB (at 1kHz, between 2 channels)	
	Dynamic Range:	More than 85dB (at 1kHz, emphasis off, "A" WTD)	
AUDIO	Wow & Flutter:	Below measurable limit	
	Headroom:	20dB	
	Analog Y/C:	S-VIDEO (4P) × 1, Y: 1.0Vp-p, 75 , C 0.286Vp-p, 75 (Burst)	
	Analog Composite:	BNC × 1, 1.0Vp-p, 75	
	Ref Video In:	BNC × 1, 1.0Vp-p, 75	
	Sync In:	BNC × 1, 1.0VP-P, 75 (Black Burst)	
	Analog Y/C:	S-VIDEO (4P) × 1, Y: 1.0Vp-p, 75 , C: 0.286Vp-p, 75 (Burst)	
	Analog Composite:	BNC × 1, 1.0Vp-p, 75	
	Monitor:	BNC × 1 (Superimpose on/off)	
	Phono Pin (Superimpose on/off):	Phono Pin (Superimpose on/off)	
AUDIO INPUT SIGNAL	Analog (CH1, CH2):	RCA × 2 (CH1/CH2), -8dBv, 47k	
	Analog (CH1, CH2):	RCA × 4 (CH1/CH2), -8dBv, 1k (Switchable to CH3, CH4 output, with DV tape playback)	
AUDIO OUTPUT SIGNAL	Headphone:	Variable level control, M3, 8	
	Headphone:	Variable level control, M3, 8	
OTHERS	Remote In:	D-sub 9-pin, RS-422A interface (option)	
	RS-232C:	D-sub 25-pin, RS-232C interface	
	Wired Remote:	For AG-A11 wired remote control (option)	
	Standard Accessory:	AC power code × 1	

AG-DV2000

GENERAL	Power Source:	120V AC ±10%, 60Hz ±0.5%		
	Power Consumption:	27W (Power Off: Approx. 7W)		
	Operating Temperature:	41°F to 104°F (5°C to 40°C)		
	Operating Humidity:	35% - 80%		
	Weight:	15.0 lbs. (6.8 kg)		
	Dimensions (W × H × D):	17-1/2" × 4-13/16" × 13-13/16" (445 × 123 × 351.5 mm)		
	SYSTEM	Television System:	EIA Standard, NTSC Color Signal: 525 lines, 60 fields	
		Recording Format:	Digital Video SD Format	
		Video Recording Format:	Digital Component	
		Audio Recording Format:	Digital PCM Stereo 16-bit (48kHz/2ch), 12-bit (32kHz/4ch)	
TAPE TRANSPORT		Tape Format:	DV, Mini-DV	
	Tape Speed:	SP: 18.812 mm/s, LP: 12.555 mm/s		
	Recording Time	123 min. with AY-DV123EB (Approx. 3 hours with AY-DV123EB in LP mode)		
	FF/REW Time:	Approx. 72 sec. with AY-DV123EB Approx. 52 sec. with AY-DVM63EB		
	VIDEO	Line In (BNC × 1, RCA × 1)*:	1.0Vp-p, 75 unbalanced	
Line Out (BNC × 2):		1.0Vp-p, 75 unbalanced		
S-Video In (4-pin × 2):		Y: 1.0Vp-p, 75 , C: 0.286Vp-p, 75		
S-Video Out (4-pin × 2):		Y: 1.0Vp-p, 75 , C: 0.286Vp-p, 75		
AUDIO		Line In (RCA × 2)*:	309mV, Input impedance 47kw	
	Mic In (M3):	0.33mV, 600 unbalanced		
	Line Out (RCA × 2):	309mV, Output impedance 1k , Load impedance 10k		
	Headphone (M3):	1 - 30mV, 8 unbalanced		
	* Simultaneous input is not possible.			
CONNECTORS	DV Input/Output:	i.LINK (IEEE 1394 - 1995)		
	System:	5-pin Editing terminal		
OTHERS	Standard Accessories:	Power Cord, S-Video Cable, AV Cable, Controller Cable, System Cord, DV Cable, Remote Control, Cleaning Tape, Battery for Remote Control, Accessories Keeping Case		

AG-A850

Power Source:	120V AC, 50/60Hz
Power Consumption:	9W
Operating Temperature:	41°F to 104°F (5°C to 40°C)
Operating Humidity:	35% to 80%
Weight:	7.1lbs. (3.2 kg)
Dimensions (W × H × D):	16-11/16" × 4-3/16" × 11" (424 × 107 × 279 mm)
Memory Capacity:	512-event
VCR Control:	Recorder: PLAY, STILL, REW, FF, STOP, EJECT, STB OFF, REC, DIAL (JOG, SHTL) Player: PLAY, STILL, REW, FF, STOP, EJECT, STB OFF, DIAL (JOG, SHTL/VAR)
Editing Control:	AUTO EDIT/END, PREVIEW, REVIEW, GO TO, GO TO OUT, ALL STOP
VCR/AUX Selection:	P1, P2, P3, P4, R, AUX1, AUX2, AUX3, AUX4
Editing Mode:	ASMBL (Assemble), INS V/A1/A2/A3/A4/TC (Insert)
Editing Function:	A/B, SPLIT, SPEED, GPI
Effect Type:	WIPE, DISS
Edit Point Input:	MARK IN, MARK OUT, ENTRY IN/OUT/DUR, LAST X, TRACK, C
EDL Input:	EVENT, TRANS, PATTERN, FROM, TO, FS, BS, LASTED, TOTAL, CORCT
Managing List:	Event Insert, Delete, Move, Copy, Renumber
Setting:	SETUP, CONFIG, T SET, SYNC GRADE, TC/CTL, CTL, RESET
Other Function:	DUMP, LOAD
Edit Reference Signal:	CTL (control signal), TC (SMPT/E/BU Time code)
Preroll Time:	0, 3, 5, 7, 10, 15 sec., AUTO
Postroll Time:	0.5, 1, 2, 3, 5, 7, 10 sec.

AG-A350

Power Source:	6V DC, 155mA
AC Adaptor:	120V AC, 50/60Hz (input)
Operating Temperature:	41°F to 104°F (5°C to 40°C)
Operating Humidity:	35% to 80%
Dimensions (W × H × D):	9-7/8" × 1-3/4" × 5-1/4" (250 × 45 × 133 mm)
Weight:	2.6 lbs. (1.2 kg)
Standard Cable Length:	Approx. 3 m
Editing Accuracy:	Standard: ± 0-frame (with reference input), ± 1-frame (4 FCF), ± 3-frame (8 FCF) Slow: ± 3-frame
Pre-roll Time:	4-step (3, 5, 7, 10 sec.)
Editing Mode:	ASSEMBLE, VIDEO INSERT, AUDIO 1/ AUDIO 2 INSERT
Editing Function:	PREVIEW, REVIEW AUDIO SPLIT
Edit Reference Signal:	CTL (CONTROL signal), TC (TIME CODE)
To VCR:	RS-422A (9-pin) × 2
REF. Video In (BNC):	75 , 1.0Vp-p, unbalanced

AJ-A250

Power Consumption:	0.81W
AC Adaptor:	AC 120V ±10%, 50/60Hz Output: DC 6V, 350mA
Operating Temperature:	41°F to 104°F (5°C to 40°C)
Operating Humidity:	35% to 80%
Dimensions (W × H × D):	9-13/16" × 1-3/4" × 5-1/4" (250 × 45 × 133 mm)
Weight:	2.4 lbs. (1.1 kg)
Standard Cable Length:	Approx. 3 m
Connector Type:	25-pin
Standard Accessory:	AC Adaptor

AG-EZ30U

DIGITAL VIDEO CAMERA	
Power Source:	Battery Pack: 7.2V, AC Adaptor: 8.4V
Power Consumption:	9W (LCD monitor on)
Recording Format:	Digital Video SD Format
Tape Format:	Mini-DV
Recording Time:	63 min. with AY-DVM63EB (SP mode), 95 min. with AY-DVM63EB (LP mode)*
Video Recording Format:	Digital Component
Video Television System:	EIA 525 lines, 60 fields, NTSC color signal
Video Output**:	1.0Vp-p, 75
Y/C (S-Video) Output**:	Y: 1.0Vp-p, 75 , C: 0.3Vp-p, 75
Audio Recording Format:	Digital PCM Stereo, 16 bits (48kHz/2CH), 12 bits (32kHz/4CH)
Audio Output**:	316mV, 600 , -10dBv, more than 10k
Audio (Mic) Input:	-70dBu, 4.7k
Image Sensor:	1/4-inch 3CCD Image Sensor
Lens:	12:1 Variable Speed Power Zoom Lens, F1.6, Focal Length: 4 to 48 mm, Filter Diameter: 43 mm
Viewfinder:	0.5-inch Color LCD Viewfinder
Standard Illumination:	1400 lux
Minimum Illumination:	2 lux (in digital gain-up mode)
Operating Temperature:	41°F to 104°F (0°C to 40°C)
Operating Humidity:	10% to 75%
Weight:	Approx. 1.52 lbs. (0.69 kg)
Dimensions (W × H × D):	3-3/16" × 4-3/16" × 7-7/16" (80 × 105 × 189 mm)
Battery Life:	AG-BP15P: Approx. 85 min. AG-BP25P: Approx. 160 min.

AC ADAPTOR VW-AD3E	
Power Source:	AC 120V, 50 to 60Hz
Power Consumption:	20W
DC Output:	DC 8.4V, 1.5A (Movie Camera Operation)
Weight:	Approx. 0.39 lbs. (0.18 kg) without Battery Pack
Dimensions (W × H × D):	3-13/16" × 1-11/16" × 2-7/8" (97 × 43 × 73 mm)

- * DV tapes recorded in LP mode or long play tapes (SP mode 80 min.) cannot be played back in a DVCPRO VCR.
- ** Need AV one touch station.
- *** Continuous recording and using VF.

DVCPRO Video Cassettes

Magnetic Layer:	Metal particle
Base Film:	Super Smooth Film
Back Coat:	Durable and Smooth Back Coating
Tape Width:	6.35 mm
Thickness	
Total Tape Thickness:	8.5 µm (6.5 µm)*
Metal Magnetic Layer:	0.2 µm (0.2 µm)*
Non-Magnetic Layer:	1.3 µm (1.3 µm)*
Undercoating Layer:	0.1 µm (0.1 µm)*
Base Film:	6.5 µm (4.5 µm)*
Back Coating Layer:	0.4 µm (0.4 µm)*
Magnetic Characteristic	
Coercivity:	183 kA/m
Squareness:	0.86
Retentivity:	370 mT

*AJ-5P92LP Specifications

* The specifications given above were measured by playing back tapes recorded by this unit on standard DVCPRO VCRs. Weight and dimensions shown are approximate. Specifications subject to change without notice. These products may be subject to export regulations.

Panasonic

PANASONIC BROADCAST & TELEVISION SYSTEMS COMPANY
DIVISION OF MATSUSHITA ELECTRIC CORPORATION OF AMERICA
www.panasonic.com/broadcast

Executive Office: 3330 Cahuenga Blvd W., Los Angeles, CA 90068
(323)436-3500

EASTERN ZONE: One Panasonic Way 4E-7, Secaucus, NJ 07094 (201)348-7621

Mid-Atlantic/New England: One Panasonic Way 4E-7, Secaucus, NJ 07094 (201)348-7621

Southeast Region: 1225 Northbrook Parkway, Ste 1-160 Suwanee, GA 30024
(770)338-6835

Central Region: 1707 N Randall Road E1-C-1, Elgin, IL 60123 (847)468-5200

WESTERN ZONE: 3330 Cahuenga Blvd W., Los Angeles, CA 90068 (323)436-3500

Dallas Region: 6226 Abington Way, Houston, TX 77008 (713)802-2726

No. CA/Northwest Region: 5870 Stoneridge, #3, Pleasanton, CA 94588 (925)416-5108

Government Marketing Department: 52 West Gude Drive, Rockville, MD 20850 (301)738-3840

Panasonic Canada Inc.
5770 Ambler Drive, Mississauga, Ontario L4W 2T3 (905)238-2115

Panasonic Sales Company (Division Of Matsushita Electric Of Puerto Rico, Inc.)
San Gabriel Industrial Park, 65th Infantry Ave., KM9.5 Carolina, Puerto Rico 00630 (809)750-4300

Matsushita Electric Industrial Co., Ltd.
Video Systems Division
2-15 Matsuba-cho, Kadoma, Osaka 571-8503 Japan
Tel. 81-6-6901-1161 Fax. 81-6-6908-5969

Panasonic Systems Sales Taiwan Co., Ltd.
Tel. 886-2-2725-9230 Fax. 886-2-2725-9292

DaeHeung Multimedia Communication Corp.
Tel. 82-2-784-0245 Fax. 82-2-784-0109

Broadcast and Communication Company of Asia, Inc.
Tel. 633-61-63 / 631-11-77 Fax. 631-18-61

Panasonic de Mexico, S.A. de C.V.
Tel. 52-5-488-1000 Fax. 52-5-488-1059

Panasonic Latin America S.A.
(Colombia, Ecuador, Panama)
Tel. 507-229-2955 Fax. 507-229-2536

Panasonic del Peru S.A.
Tel. 51-1-452-9470 Fax. 51-1-452-9415

Teknos Comunicaciones S.A. (Chile)
Tel. 56-2-555-5530 Fax. 56-2-551-9571

Panasonic do Brasil Ltda
Tel. 55-11-889-4031 Fax. 55-11-889-4002



Certificate No. EC95J1010 ISO9001 / BS5750 - PART 1
FM No. 28369