



**PRODUCT LITERATURE**

Lennox Industries Inc.  
Dallas, Texas

# INSTALLATION INSTRUCTIONS

GWB8-050E-3, GWB8-075E-3  
GWB8-100E-3, GWB8-125E-3  
GWB8-150E-3, 2GWB8-170E-3  
GWB8-200E-3

## GAS FIRED BOILER



### RETAIN THESE INSTRUCTIONS FOR FUTURE REFERENCE

*These instructions must be affixed on  
or adjacent to the boiler.*

#### **WARNING**

Improper installation, adjustment, alteration, service, or maintenance could result in death or serious injury. Refer to this manual for assistance. For additional information consult a qualified installer, service agency, or the gas supplier.

#### **GAS-FIRED HOT WATER BOILERS**

These Gas-Fired Water boilers are low pressure, sectional cast iron boilers Design Certified by CSA (Canadian Standards Association) for use with Natural and Propane Gases. They are constructed and hydrostatically tested for a maximum working pressure of 100 psi with A.S.M.E. (American Society of Mechanical Engineers) Boiler and Pressure Vessel Code Section IV Standards for Cast Iron Heating Boilers.

This boiler cannot be used with all types of chimneys. Read these instructions carefully before installing.



C.S.A. Certified  
For Natural Gas Or Propane



H  
Tested For 100 psi.  
ASME  
Working Pressure

Figure 1 - Dimensions

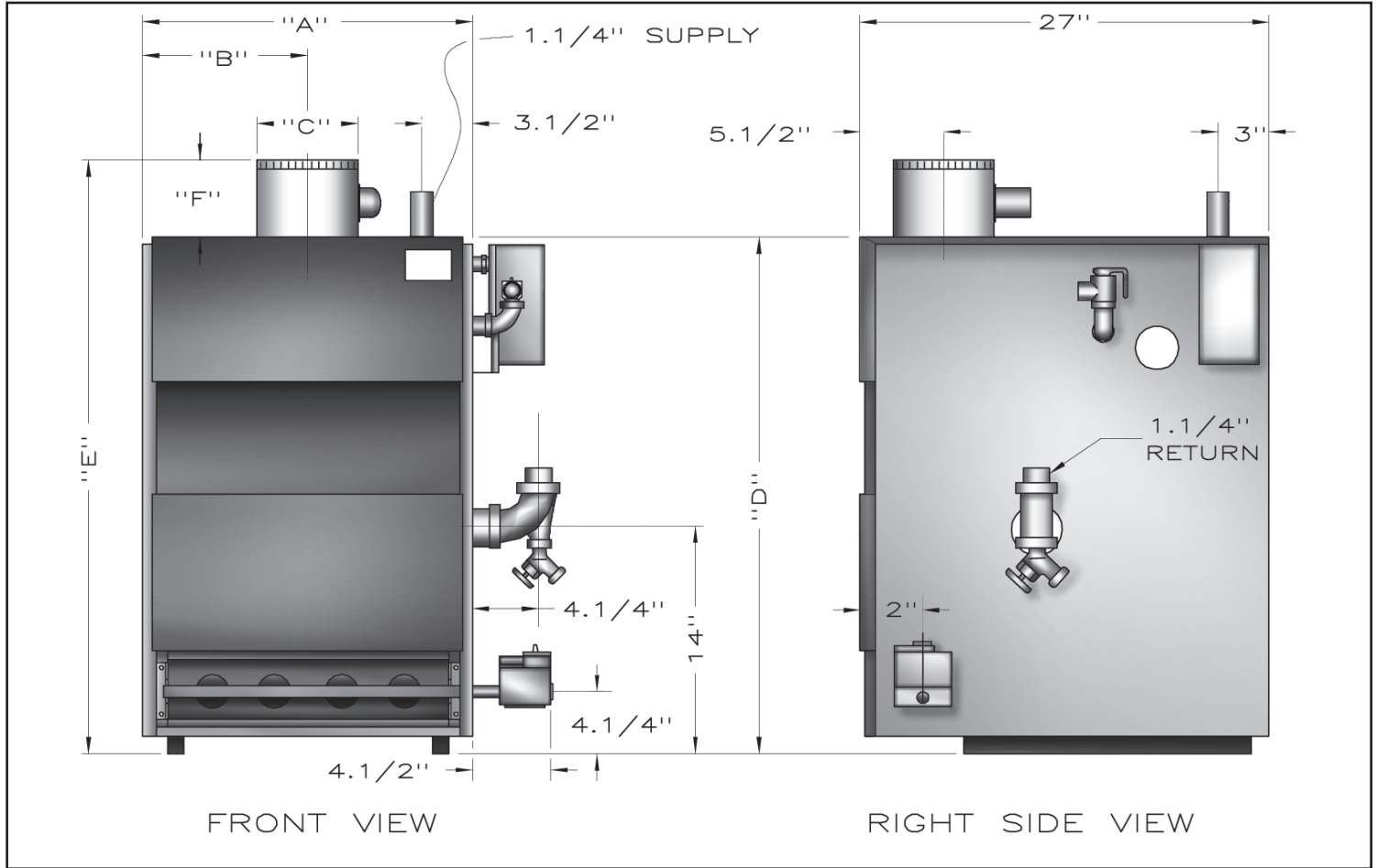

Table 1 - Dimensions

| Boiler No. | Natural Gas Inlet* | Dimensions |         |    |         |         |        | Pump size Supply & Return Tappings |
|------------|--------------------|------------|---------|----|---------|---------|--------|------------------------------------|
|            |                    | A          | B       | C  | D       | E       | F      |                                    |
| 50         | 1/2"               | 11 1/8"    | 5 1/2"  | 4" | 30 3/4" | 36 1/4" | 5 3/4" | 1 1/4"                             |
| 75         | 1/2"               | 15         | 7 1/2"  | 5" | 30 3/4" | 37 3/4" | 5 3/4" | 1 1/4"                             |
| 100        | 1/2"               | 15         | 7 1/2"  | 6" | 30 3/4" | 37 1/4" | 6"     | 1 1/4"                             |
| 125        | 1/2"               | 18 7/8"    | 9 1/2"  | 6" | 30 3/4" | 37 1/4" | 6"     | 1 1/4"                             |
| 150        | 1/2"               | 18 7/8"    | 9 1/2"  | 7" | 30 3/4" | 37 3/4" | 6 3/4" | 1 1/4"                             |
| 170        | 1/2"               | 22 3/4"    | 11 1/2" | 7" | 30 3/4" | 38 3/4" | 6 3/4" | 1 1/4"                             |
| 200        | 1/2"               | 22 3/4"    | 11 1/2" | 8" | 30 3/4" | 38 3/4" | 7 3/4" | 1 1/4"                             |

\* Propane gas inlet, all units, 1/2"

## TABLE OF CONTENTS

|  |    |
|--|----|
| 1 - Ratings & Data - Natural Gas & Propane Gas ..... | 4  |
| 2 - Installation Procedure .....                     | 5  |
| 3 - Ventilation & Combustion Air .....               | 6  |
| 4 - Connecting Supply and Return Piping .....        | 7  |
| 5 - Vent Installation .....                          | 12 |
| 6 - Vent System Modification .....                   | 12 |
| 7 - Vent Damper Installation & Instructions .....    | 13 |
| 8 - Connecting Gas Service .....                     | 14 |
| 9 - Electrical Section .....                         | 15 |
| 10 - Wiring Diagram .....                            | 16 |
| 11 - Lighting Instructions .....                     | 19 |
| 12 - Normal Sequence of Operation .....              | 20 |
| 13 - General Instructions .....                      | 20 |
| 14 - Checking Gas Input Rate To Boiler .....         | 22 |
| Appendix A - Control Module .....                    | 23 |

### Safety Symbols & Warnings

The following defined symbols are used throughout this manual to notify the reader of potential hazards of varying risk levels.

#### **DANGER**

Indicates a hazardous situation which, if not avoided, WILL result in death or serious injury

#### **WARNING**

Indicates a hazardous situation which, if not avoided, could result in death or serious injury.

#### **CAUTION**

Indicates a hazardous situation which, if not avoided, could result in minor or moderate injury.

#### **NOTICE**

Used to address practices not related to personal injury.

**KEEP THIS MANUAL NEAR BOILER  
RETAIN FOR FUTURE REFERENCE**

**IMPORTANT: Read the following instructions  
COMPLETELY before installing!!**

#### **WARNING**

Fire, explosion, asphyxiation and electrical shock hazard. Improper installation could result in death or serious injury. Read this manual and understand all requirements before beginning installation.

#### **WARNING**

Keep boiler area clear and free from combustible materials, gasoline and other flammable vapors and liquids.  
DO NOT obstruct air openings to the boiler room. Modification, substitution or elimination of factory equipped, supplied or specified components may result in personal injury or loss of life.  
TO THE OWNER - Installation and service of this boiler must be performed by a qualified installer.  
TO THE INSTALLER - Leave all instructions with boiler for future reference.  
When this product is installed in the Commonwealth of Massachusetts the installation must be performed by a Licensed Plumber or Licensed Gas Fitter.



**Table 2 - Ratings and Capacities**

| Boiler No.  | (1)<br>Input Mbh | (1)<br>Heating Capacity Mbh | (2)<br>Net AHRI Rating Water Mbh | AFUE | No. of Burners | (3)<br>Recommended Air Cushion Tank | Water Content (Gals.) | (1)<br>High Altitude Input Mbh |
|-------------|------------------|-----------------------------|----------------------------------|------|----------------|-------------------------------------|-----------------------|--------------------------------|
| GWB8-50E-3  | 50               | 52                          | 36.3                             | 83.5 | 1              | 15                                  | 2.4                   | 45                             |
| GWB8-75E-3  | 75               | 63                          | 54.8                             | 83.1 | 2              | 15                                  | 4.0                   | 67.5                           |
| GWB8-100E-3 | 100              | 83                          | 72                               | 83.0 | 2              | 30                                  | 4.0                   | 90                             |
| GWB8-125E-3 | 125              | 104                         | 90                               | 82.0 | 3              | 30                                  | 5.6                   | 112.5                          |
| GWB8-150E-3 | 150              | 124                         | 107.8                            | 83.0 | 3              | 30                                  | 5.6                   | 135                            |
| GWB8-170E-3 | 170              | 139                         | 121                              | 82.0 | 4              | 30                                  | 7.2                   | 153                            |
| GWB8-200E-3 | 200              | 165                         | 143.4                            | 82.0 | 4              | 30                                  | 7.2                   | 180                            |

**EXPLANATORY NOTES**

- All boilers are design certified for installation on noncombustible floor.
  - For installation on combustible floors use combustible floor kit.
  - Recommended chimney height 20 feet. In special cases where conditions permit, chimney height may be reduced to 10 feet. Refer to the latest revision of NFGC part 11.
  - Electric service to be 120 Volts, 15 Amps, 60 Hz.
  - The MEA number for the this boiler is 19-79-E.
- (1) Input rating for sea level to 2,000 ft. (610m) above sea level.  
**United States**, over 2000 ft (610m) above sea level. Reduce input rate 4% for every 1000 ft (304m) above sea level.  
**Canada**, 2000 ft (610m) to 4500 (1350m) above sea level reduce input per table. Over 4500 ft (1350m) above sea level. Contact Provincial authority having jurisdiction.
- (2) Net AHRI Water Ratings shown based on piping and pickup allowance of 1.15. Consult manufacturer before selecting boiler for installations having unusual piping and pickup requirements, such as intermittent system operation, extensive piping systems, etc.  
 For forced hot water systems where boiler and all piping within area to be heated, boiler may be selected on basis of its heating capacity.
- (3) Tank sized for non-ferrous baseboard or radiant panel systems. Increase size for cast iron baseboard and radiation.

**STANDARD EQUIPMENT:** Boiler Jacket, Cast Iron Boiler Battery, High Limit Control, Intermittent Electric Ignition Pilot System, Vent Damper Relay, Temperature/Pressure Gauge, Circulator With Return Piping To Boiler, Main Gas Burners, Gas Control (Includes Automatic Gas Valve, Gas Pressure Regulator, Intermittent Pilot, Safety Shutoff, Pilot Flow Adjustment, Pilot Filter), A.S.M.E. Relief Valve, Drain Valve, Spill Switch, Rollout Switch, Combination Gas Control, Automatic Vent Damper. Wiring Harness, Thermocouple, Non-linting Safety Pilot.

## 2 - INSTALLATION PROCEDURE

### **⚠ WARNING**

Improper installation, adjustment, alteration, service or maintenance could result in death or serious injury.

1. Installation must conform to the requirements of the authority having jurisdiction or, in the absence of such requirements, to the National Fuel Gas Code, ANSI Z223.1/NFPA 54.
2. Where required by the authority having jurisdiction, the installation must conform to the Standard for Controls and Safety Devices for Automatically fired Boilers, ANSI/ASME CSD-1.
3. Boiler series is classified as a Category I. Vent installation shall be in accordance with Venting of Equipment, National Fuel Gas Code, ANSI Z223.1/NFPA 54 or applicable provisions of the local building codes.
4. Boiler has met safe lighting and other performance criteria with the gas manifold and control assembly on the boiler per the latest revision of ANSI Z21.13/CGA 4.9.
5. Install boiler such that gas ignition system components are protected from water (dripping, spraying, rain, etc.) during appliance operation and service, (circulator replacement, condensate trap, control replacement, etc.).
6. Locate boiler on level, solid base as near chimney as possible and centrally located with respect to heat distribution system as practical.
7. Allow 24 inches (610mm ) at front and right side for servicing and cleaning.
8. When installed in utility room, door should be wide enough to allow largest boiler part to enter, or to permit replacement of another appliance such as water heater.

### **⚠ WARNING**

Fire hazard. Do not install boiler on combustible flooring or carpeting. Failure to follow these instructions could result in death or serious injury.

9. FOR INSTALLATION ON NON-COMBUSTIBLE FLOORS ONLY - For installation on combustible flooring special base must be used. (See Repair Parts, Optional Kits Manual). Do not install boiler on carpeting. Minimum clearances to combustible construction are:

|                        |                |
|------------------------|----------------|
| TOP .....              | 18 IN. (457mm) |
| FRONT .....            | ALCOVE *       |
| FLUE CONNECTOR .....   | 6 IN. (152mm)  |
| REAR .....             | 4 IN. (102mm)  |
| CONTROL SIDE .....     | 9 IN. (229mm)  |
| OTHER SIDE .....       | 3 IN. (76mm)   |
| HOT WATER PIPING ..... | 2 IN. (51mm)   |

NOTE: Greater clearances for access should supersede fire protection clearances.

\* Definition of Alcove is three sided space with no wall in front of boiler. ANSI standard for alcove is 18 inches from front of appliance to leading edge of side walls as shown below.

### **Minimum Clearances to Combustible Construction** (as seen from above)

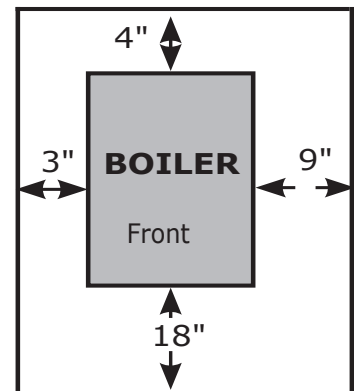

### 3 - VENTILATION & COMBUSTION AIR

Provide combustion air and ventilation air in accordance with the section "Air for Combustion and Ventilation," of the National Fuel Gas Code, ANSI Z223.1/NFPA 54 or applicable provisions of local building codes.

Provide make-up air where exhaust fans, clothes dryers, and kitchen ventilation equipment interfere with proper operation.

National Fuel Gas Code recognizes several methods of obtaining adequate ventilation and combustion air. Requirements of the authority having jurisdiction may override these methods.

- Engineered Installations. Must be approved by authority having jurisdictions.
- Mechanical Air Supply. Provide minimum of 0.35 cfm per Mbh for all appliances located within space. Additional requirements where exhaust fans installed. Interlock each appliance to mechanical air supply system to prevent main burner operation when mechanical air supply system not operating.
- All Indoor Air. Calculate minimum volume for all appliances in space. Use a different method if minimum volume not available.
  - Standard Method. Cannot be used if known air infiltration rate is less than 0.40 air changes per hour. See Table 3 for space with boiler only. Use equation for multiple appliances.  

$$\text{Volume} \geq 50 \text{ ft}^3 \times \text{Total Input [Mbh]}$$
  - Known Air Infiltration Rate. See Table 3 for space with boiler only. Use equation for multiple appliances. Do not use an air infiltration rate (ACH) greater than 0.60.  

$$\text{Volume} \geq 21 \text{ ft}^3/\text{ACH} \times \text{Total Input [Mbh]}$$
  - Refer to National Fuel Gas Code for opening requirements between connection indoor spaces.

- All Outdoor Air. Provide permanent opening(s) communicating directly or by ducts with outdoors.
  - Two Permanent Opening Method. Provide opening commencing within 12 inches of top and second opening commencing within 12 inches of bottom enclosure.
    - Direct communication with outdoors or communicating through vertical ducts. Provide minimum free area of 1 in<sup>2</sup> per 4 Mbh of total input rating of all appliances in enclosure.
    - Communicating through horizontal ducts. Provide minimum free area of 1 in<sup>2</sup> per 2 Mbh of total input rating of all appliances in enclosure.
  - One Permanent Opening Method. Provide opening commencing within 12 inches of top of enclosure. Provide minimum clearance of 1 inch on sides and back and 6 inches on front of boiler (does not supersede clearance to combustible materials).
- Refer to National Fuel Gas Code for additional requirements for louvers, grilles, screens and air ducts.
- Combination Indoor and Outdoor Air. Refer to National Fuel Gas Code for application information.

**Table 3 - Space With Boiler Only**

|           |                 | Room Cubic Feet Volume  |       |       |       |      |      |
|-----------|-----------------|---|-------|-------|-------|------|------|
| Input Mbh | Standard Method | Known Air Infiltration Rate Method (ACH - Air Changes Per Hour) |       |       |       |      |      |
|           |                 | 0.1   | 0.2   | 0.3   | 0.4   | 0.5  | 0.6  |
| 50        | 2500            | 10500   | 5250  | 3500  | 2625  | 2100 | 1750 |
| 75        | 3750            | 15750   | 7875  | 5250  | 3938  | 3150 | 2625 |
| 100       | 5000            | 21000   | 10500 | 7000  | 5250  | 4200 | 3500 |
| 125       | 6250            | 26250   | 13125 | 8750  | 6563  | 5250 | 4375 |
| 150       | 7500            | 31500   | 15750 | 10500 | 7875  | 6300 | 5250 |
| 170       | 8500            | 35700   | 17850 | 11900 | 8925  | 7140 | 5950 |
| 200       | 10000           | 42000   | 21000 | 14000 | 10500 | 8400 | 7000 |



### WARNING

Burn or Scald Hazard. Discharge line shall be installed to relief valve outlet connection to avoid burns, scalding, or water damage due to discharge of steam and/or hot water during operation.

Discharge line shall:

- connect to relief valve outlet and piped down to safe point of disposal. Check local codes for maximum distance from floor or allowable safe point of discharge.
- be of pipe size equal to or greater than that of the relief valve outlet over the entire length of discharge line;
- have no intervening shutoff valve between safety relief valve and discharge to atmosphere (do not plug or place any obstruction in discharge line).
- terminate freely to atmosphere where any discharge will be clearly visible and at no risk of freezing;
- allow complete drainage of the valve and the discharge line;
- be independently supported and securely anchored to avoid applied stress on the relief valve;
- be as short and straight as possible;
- terminate with plain end (not threaded);
- be constructed of material suitable for exposure to temperatures of 375° F (191°C); or greater.

Refer to local codes and appropriate ASME Boiler and Pressure Vessel Code for additional installation requirements.

**Figure 2 - Safety Relief Valve**

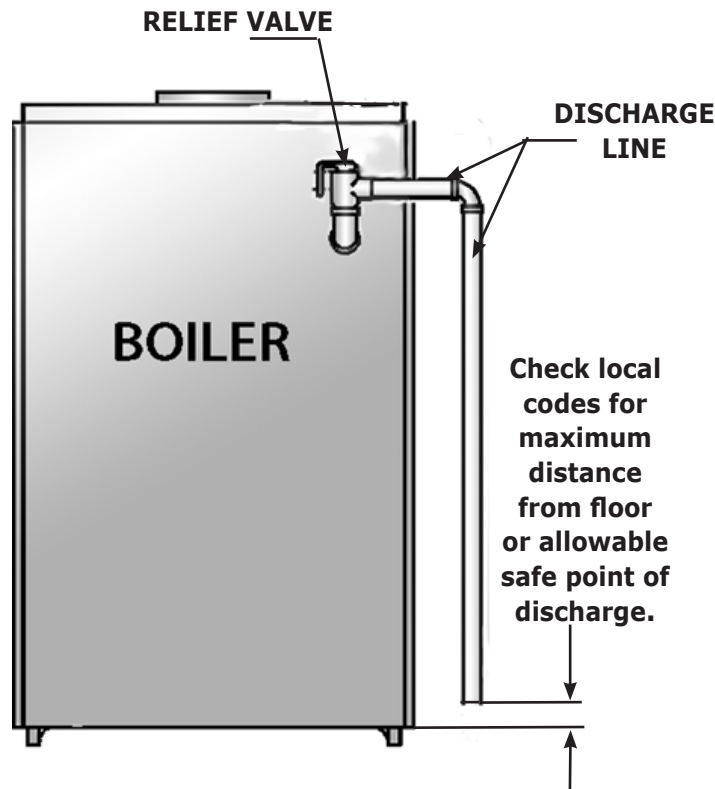



## 4 - CONNECTING SUPPLY AND RETURN PIPING

Circulators in following illustrations are mounted on system supply side, mounting on system return side is also acceptable practice.

**Figure 3 - Circulators Mounted on Supply System, Boiler Used In Configuration with Chiller System. See Special Conditions, Page 9**

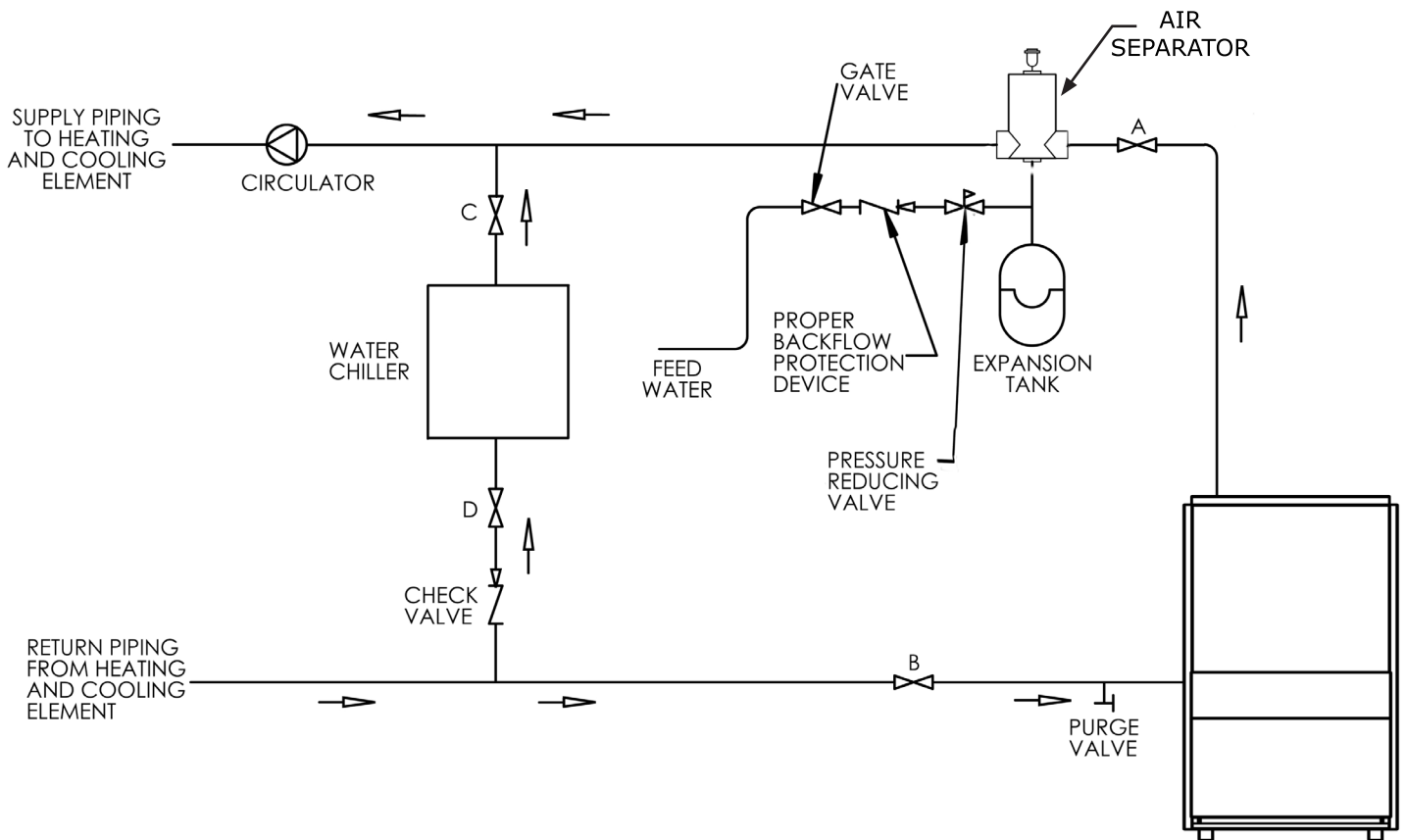

1. Boiler used in connection with refrigeration system, install so chilled medium is piped in parallel with boiler with appropriate valves to prevent chilled medium from entering boiler. See Figure 2.
  2. Boiler piping system of hot water boiler connected to heating coils located in air handling units where they may be exposed to refrigerated air circulation must be equipped with flow control valves or other automatic means to prevent gravity circulation of boiler water during cooling cycle.
  3. Hot water boilers installed above radiation level or as required by authority having jurisdiction must be provided with low water cut-off device.
  4. Boiler connected to heating system utilizing multiple zoned circulators, each circulator must be supplied with flow control valve to prevent gravity circulation.
  5. Hot water boilers and system must be filled with water and maintained to minimum pressure of 12 psi.
  6. Bypass piping is optional which gives ability to adjust supply boiler water temperature to fit system or condition of installation. This method of piping, however, is not typically required for baseboard heating systems. Typical installations where bypass piping is used are as follows:
    - A. This method is used to protect boilers from condensation forming due to low temperature return water. Generally noticed in large converted gravity systems or other large water volume systems. Figures 4 and 5.
    - B. These methods are used to protect systems using radiant panels and material they are encased in from high temperature supply water from boiler and protect boiler from condensation.
- NOTE#1:** When using bypass piping, adjust valves V1 & V2 until desired system temperature is obtained. See Figure 5, page 9.
- NOTE#2:** Bypass loop must be same size piping as supply and return piping.
7. Installation using circulators and zone valves are shown in Figures 6 through 9. For further piping information refer to AHRI Installation and Piping Guide.



## 4 - CONNECTING SUPPLY AND RETURN PIPING

**Figure 4 - Bypass Piping With Mixing Valve**

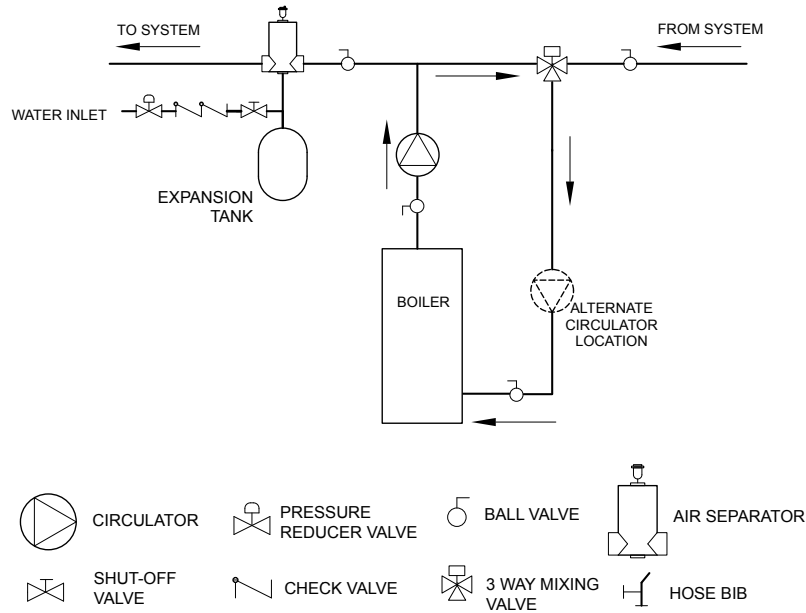

**Figure 5 - Bypass Piping - Fixed Low Temp Only With Zone Valve**

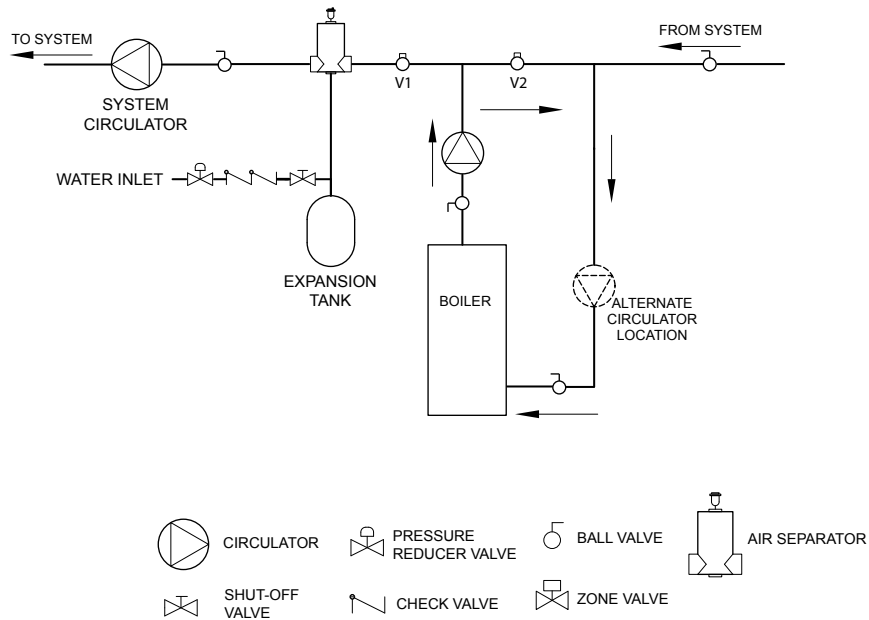

### **⚠ WARNING**

Burn and scald hazard. Safety relief valve could discharge steam or hot water during operation. Install discharge piping per these instructions.

8. Install discharge piping from safety relief valve. See Warning, Page 7.

## 4 - CONNECTING SUPPLY AND RETURN PIPING

Figure 6 - Single Zone System With DHW

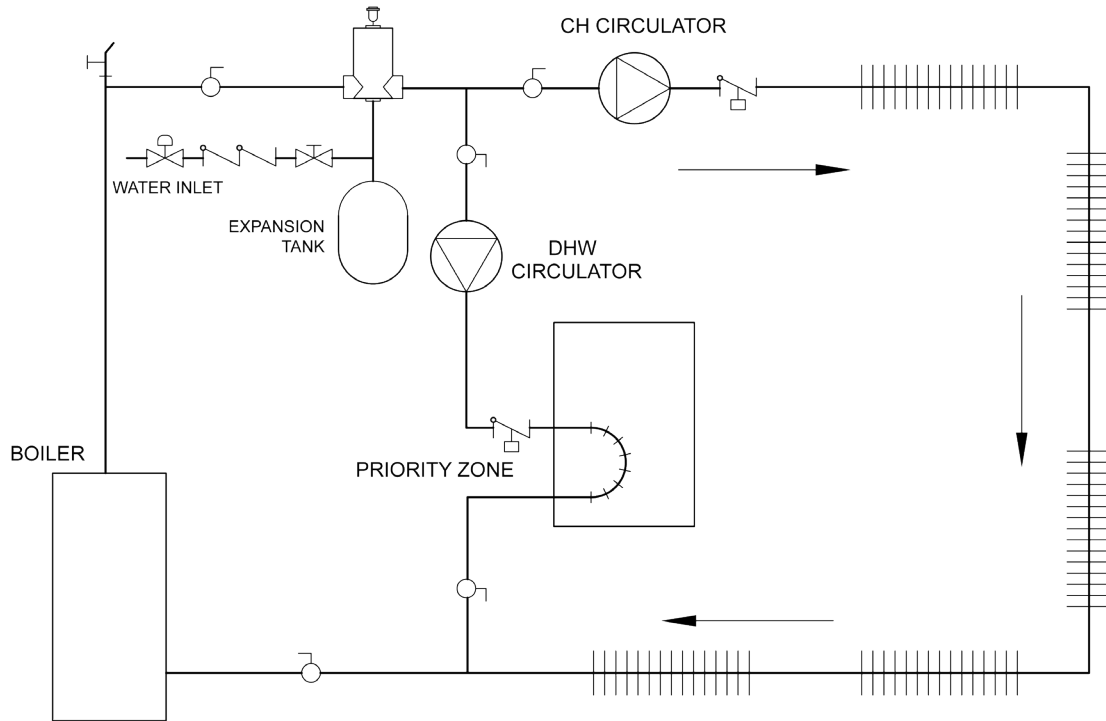
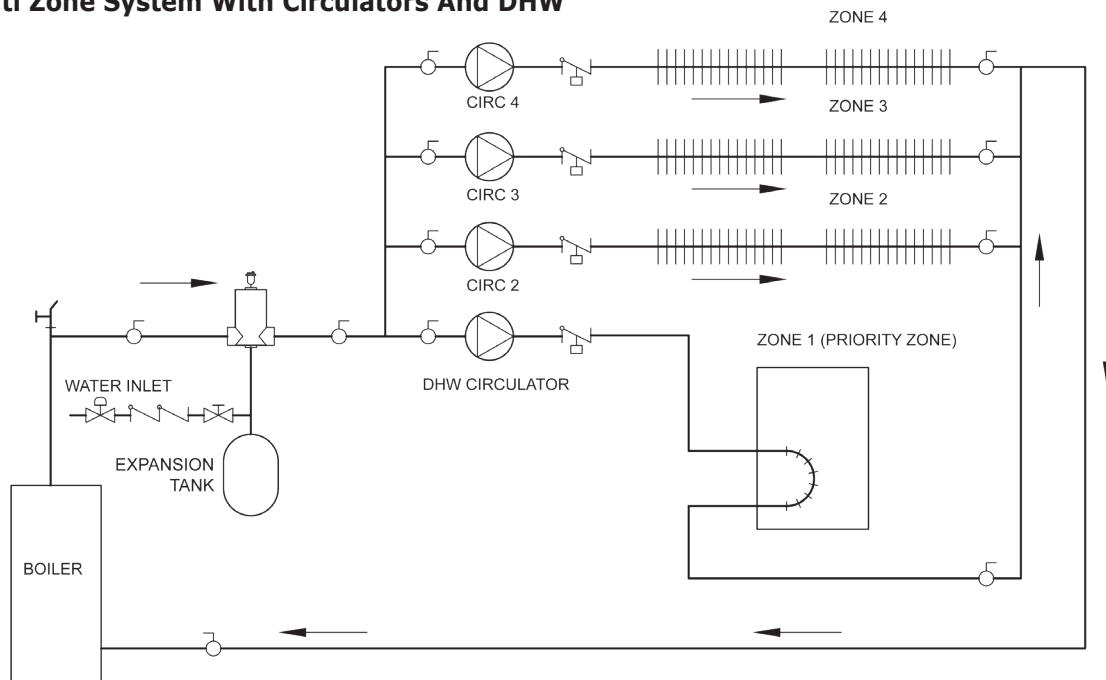

Figure 7 - Multi Zone System With Circulators And DHW



## 4 - CONNECTING SUPPLY AND RETURN PIPING

Figure 8 - Multi Zone System With Zone Valves And DHW (With Circulator)

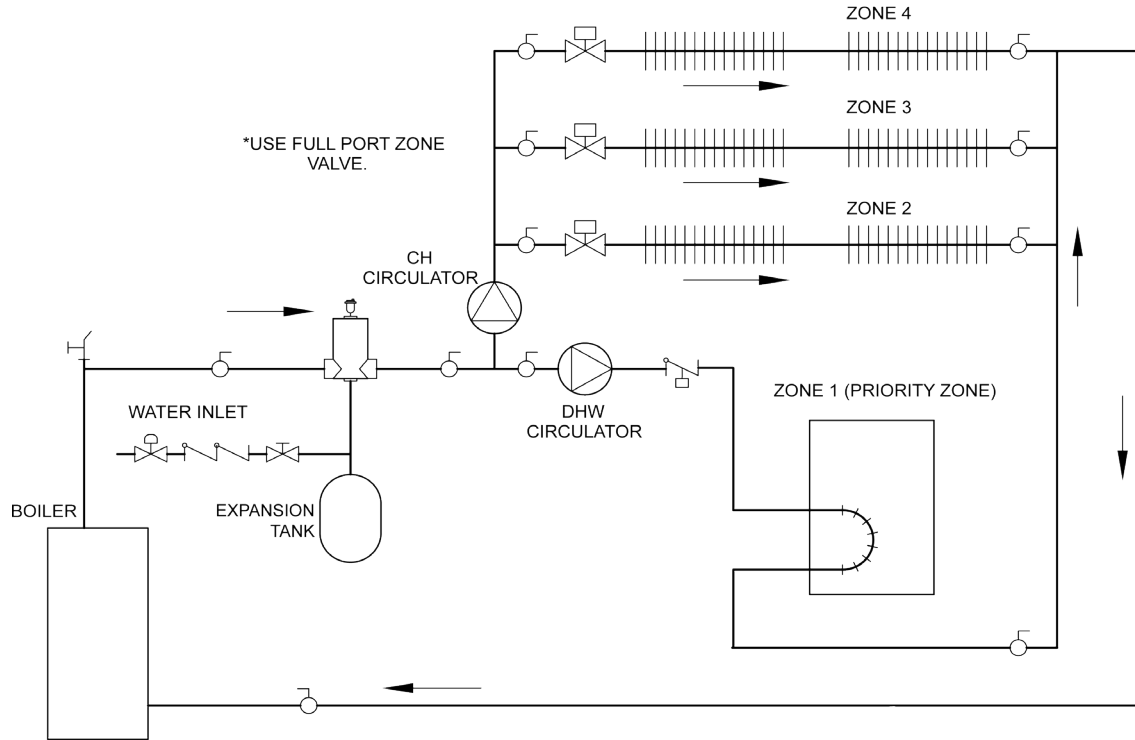
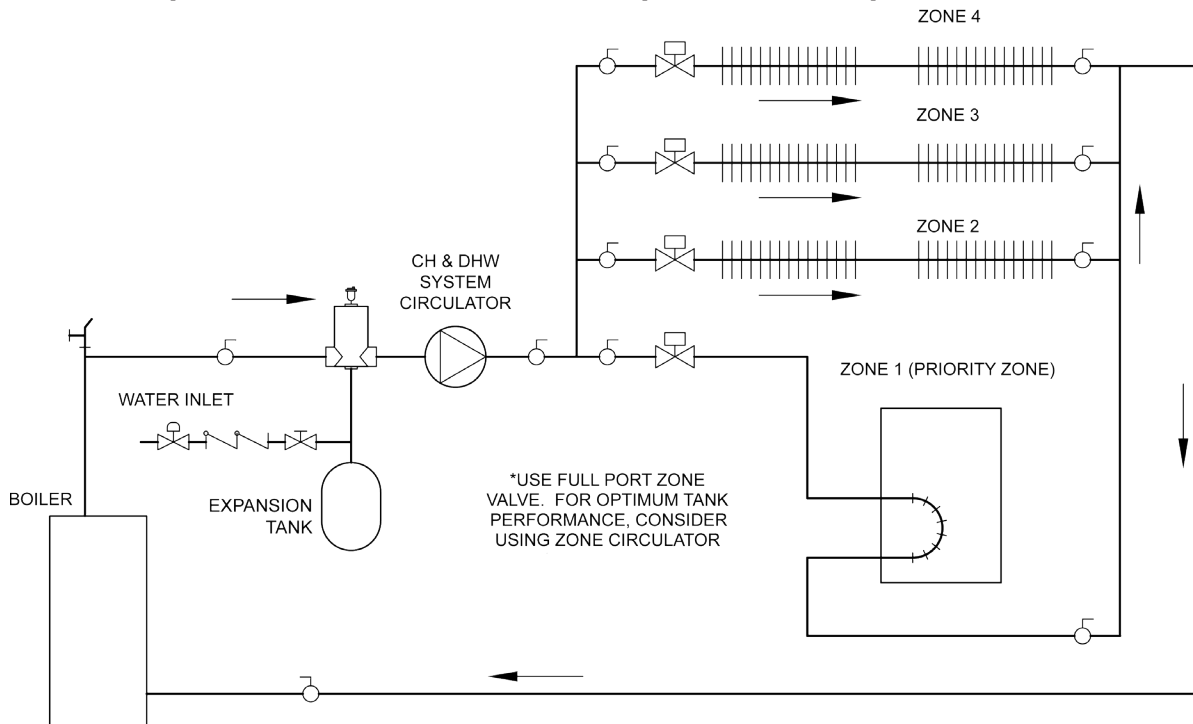

Figure 9 - Multi Zone System With Zone Valves And DHW (With Zone Valve)



## 5 - VENT INSTALLATION

### WARNING

Boiler and venting installations shall be performed by a qualified expert and in accordance with the appropriate manual. Installing or venting boiler or other gas appliance with improper methods or materials may result in serious injury or death due to fire or to asphyxiation from poisonous gases such as carbon monoxide which is odorless and invisible.

### WARNING

Do not connect boiler to any portion of mechanical draft system operating under positive pressure.

1. Vent pipe must slope upward from the boiler not less than 1/4 inch for every 1 foot (21mm/m) to vent terminal.
2. Horizontal portions of venting system shall be supported rigidly every 5 feet and at the elbows. No portion of vent pipe should have any dips or sags.
3. Boiler series is classified as a Category I. Vent installation shall be in accordance with "Venting of Equipment," of the National Fuel Gas Code, ANSI Z223.1/NFPA 54 or applicable provisions of the local building codes.
4. Inspect chimney. Verify chimney is constructed according to NFPA 211. Vent or vent connector shall be Type B or metal pipe having resistance to heat and corrosion not less than that of galvanized sheet steel or aluminum not less than 0.016 inch thick (No. 28 Ga).
5. Connect flue pipe from draft hood to chimney. Bolt or screw joints together to avoid sags. Flue pipe should not extend beyond inside wall of chimney. Do not install manual damper in flue pipe or reduce size of flue outlet except as provided by the latest revision of ANSI Z223.13. Protect combustible ceiling and walls near flue pipe with fireproof insulation. Where two or more appliances vent into a common flue, the area of the common flue must be at least equal to the area of the largest flue plus 50 percent of the area of each additional flue.

## 6 - VENT SYSTEM MODIFICATION

When an existing boiler is removed from a common venting system, the system is likely to be too large for the proper venting of the appliances still connected to it. If this situation occurs, the following test procedure must be followed:

### REMOVAL OF BOILER FROM VENTING SYSTEM

At the time of removal of an existing boiler, the following steps shall be followed with each appliance remaining connected to the common venting system placed in operation, while the other appliances remaining connected to the common venting system are not in operation.

1. Seal an unused opening in the common venting system.
2. Visually inspect the venting system for proper size and horizontal pitch and determine there is no blockage or restriction, leakage, corrosion and other deficiencies which could cause an unsafe condition.
3. Insofar as is practical, close all building doors and windows and all doors between the space in which the appliances remaining connected to the common venting system are located and other spaces of the building. Turn on clothes dryers and any other appliance not connected to the common venting system. Turn on any exhaust fans, such as range hoods and bathroom exhausts, so they operate at maximum speed. Do not operate a summer exhaust fan. Close fireplace dampers.
4. Place in operation the appliance being inspected. Follow the lighting instructions. Adjust thermostat so appliance will operate continuously.
5. Test for spillage at the draft hood relief opening after 5 minutes of main burner operation. Use the flame of a match or candle, or smoke from a cigarette, cigar or pipe.
6. After it has been determined that each appliance remaining connected to a common venting system properly vents when tested as outlined above, return doors, windows, exhaust fans, fireplace dampers and any other gas burning appliances to their previous condition of use.
7. Any improper operation of the common venting system should be corrected so the installation conforms with the National Fuel Gas Code, ANSI Z223.1/NFPA 54. When re-sizing any portion of the common venting system, the common venting system should be re-sized to approach the minimum size determined using the appropriate tables in Chapter 13 of the National Fuel Gas Code, ANSI Z223.1/NFPA 54.

## 7 - VENT DAMPER INSTALLATION & INSTRUCTIONS

### DAMPER INSTALLATION

Follow Damper installation instructions provided with damper. See **Figure 10**.

### DAMPER INSTRUCTIONS

1. Verify only boiler is serviced by Vent Damper. Figure 11.
2. Clearance of not less than 6 inches (152mm) between Vent Damper and combustible material must be maintained. Additional clearance should be allowed for service of Vent Damper.
3. Vent Damper must be in the open position when appliance main burners are operating.
4. Vent Damper position indicator must be in visible location following installation.
5. Thermostat's heat anticipator must be adjusted to match total current draw of all controls associated with boiler during heating cycle.

**Figure 10 - Damper Motor Wiring**

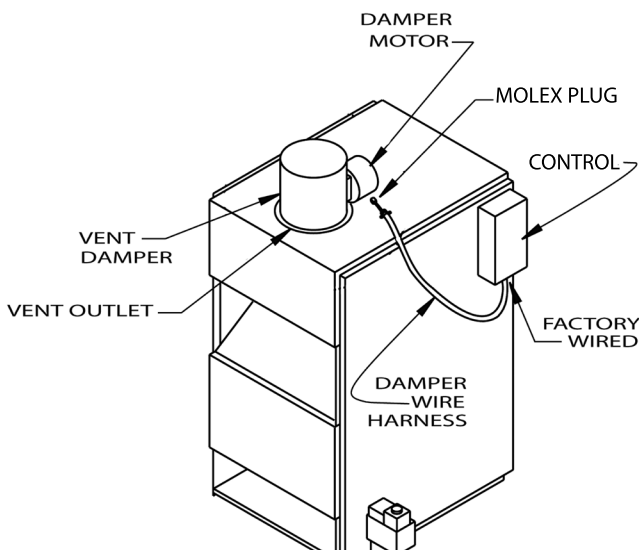

**Figure 11 - Vent Damper Placement**

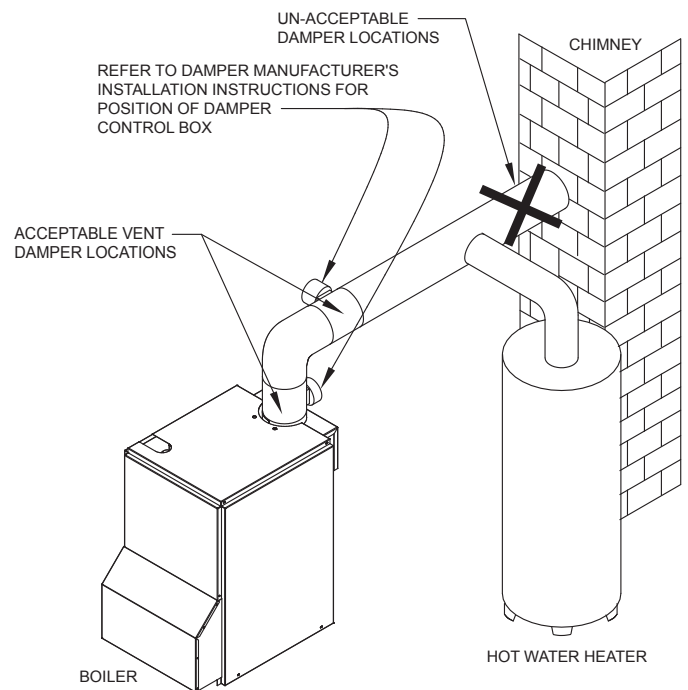

**CAUTION**

**WHAT TO DO IF YOU SMELL GAS**

- Do not try to light any appliance.
- Do not touch any electrical switch; do not use any phone in your building.
- Immediately call your gas supplier from a neighbor's phone. Follow gas supplier's instructions.
- If you cannot reach your gas supplier, call the fire department.

**General**

- Use piping materials and joining methods acceptable to authority having jurisdiction. In absence of such requirements National Fuel gas Code, ANSI Z223.1/ NFPA 54
- Size and install gas piping system to provide sufficient gas supply to meet maximum input at not less than minimum supply pressure. See Table 4.
- Support piping with hooks straps, bands, brackets, hangers, or building structure components to prevent or dampen excessive vibrations and prevent strain on gas connection. Boiler will not support piping weight.
- Use thread (joint) compound (pipe dope) suitable for liquefied petroleum gas.
- Install field sourced manual main shutoff valve, ground joint union, and sediment trap upstream of gas valve. See Figure 12.

**Figure 12 - Gas Piping**

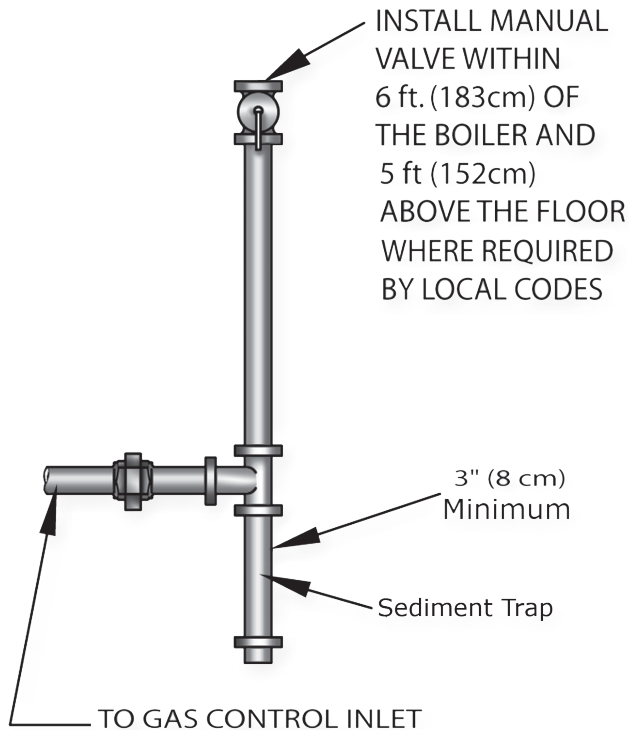

|                      | Natural Gas | Propane    |
|----------------------|-------------|------------|
| Min. Supply Pressure | 5" w.c.     | 11" w.c.   |
| Max. Supply Pressure | 13.5" w.c.  | 13.5" w.c. |
| Manifold Pressure    | 3.5" w.c.   | 10.5" w.c. |

**DANGER**

Fire Hazard. Do not use matches, candles, open flames, or other methods providing ignition source. Failure to comply will result in death or serious injury.

**Leak Check Gas Piping**

Pressure test boiler and gas connection before placing boiler in operation.

- Pressure test over 1/2 psig (3.5 kPa). Disconnect boiler and its individual gas shutoff valve from gas supply system.
- Pressure test at 1/2 psig (3.5 kPa) or less. Isolate boiler from gas supply system by closing manual gas shutoff valve.
- Locate leakage using gas detector, noncorrosive detection fluid, or other leak detection method acceptable to authority having jurisdiction. Do not use matches, candles, open flames, or other methods providing ignition source.
- Correct leaks immediately and retest.

**MAXIMUM CAPACITY OF PIPE IN CUBIC FEET OF GAS/HOUR**

(Gas Pressure = 0.5 psig or less, Pressure Drop = 5 in. w/c)

| Length of Pipe (Feet) | Nominal Iron Pipe Size |      |     |        |
|-----------------------|------------------------|------|-----|--------|
|                       | 1/2"                   | 3/4" | 1"  | 1 1/4" |
| 10                    | 175                    | 360  | 680 | 1400   |
| 20                    | 120                    | 250  | 465 | 950    |
| 30                    | 97                     | 200  | 375 | 770    |
| 40                    | 82                     | 170  | 320 | 660    |
| 60                    | 66                     | 138  | 260 | 530    |
| 80                    | 57                     | 118  | 220 | 460    |
| 100                   | 50                     | 103  | 195 | 400    |

For additional information refer to the National Fuel Gas Code Handbook.

### **WARNING**

Electrical shock hazard. Turn OFF electrical power supply at service panel before making electrical connections. Failure to do so could result in death or serious injury.

#### **ELECTRICAL WIRING**

**See wiring diagrams on the following two pages for details.**

Electrically bond boiler to ground in accordance with requirements of authority having jurisdiction. Refer to National Electrical Code, ANSI/NFPA 70.

#### **THERMOSTAT INSTALLATION**

1. Thermostat should be installed on inside wall about four feet above floor.
2. NEVER install thermostat on outside wall.
3. Do not install thermostat where it will be affected by drafts, hot or cold pipes, sunlight, lighting fixtures, televisions, fireplace, or chimney.
4. Check thermostat operation by raising and lowering thermostat setting as required to start and stop burners.
5. Instructions for final adjustment of thermostat are packaged with thermostat (adjusting heating anticipator, calibration, etc.)



# 10 - WIRING DIAGRAM

**Figure 13 - Integrated High Limit Electronic Ignition Control (240008781)**

**⚠ WARNING**

Modification, substitution or elimination of factory equipped, supplied or specified components may result in personal injury or loss of life.

WIRING DIAGRAM

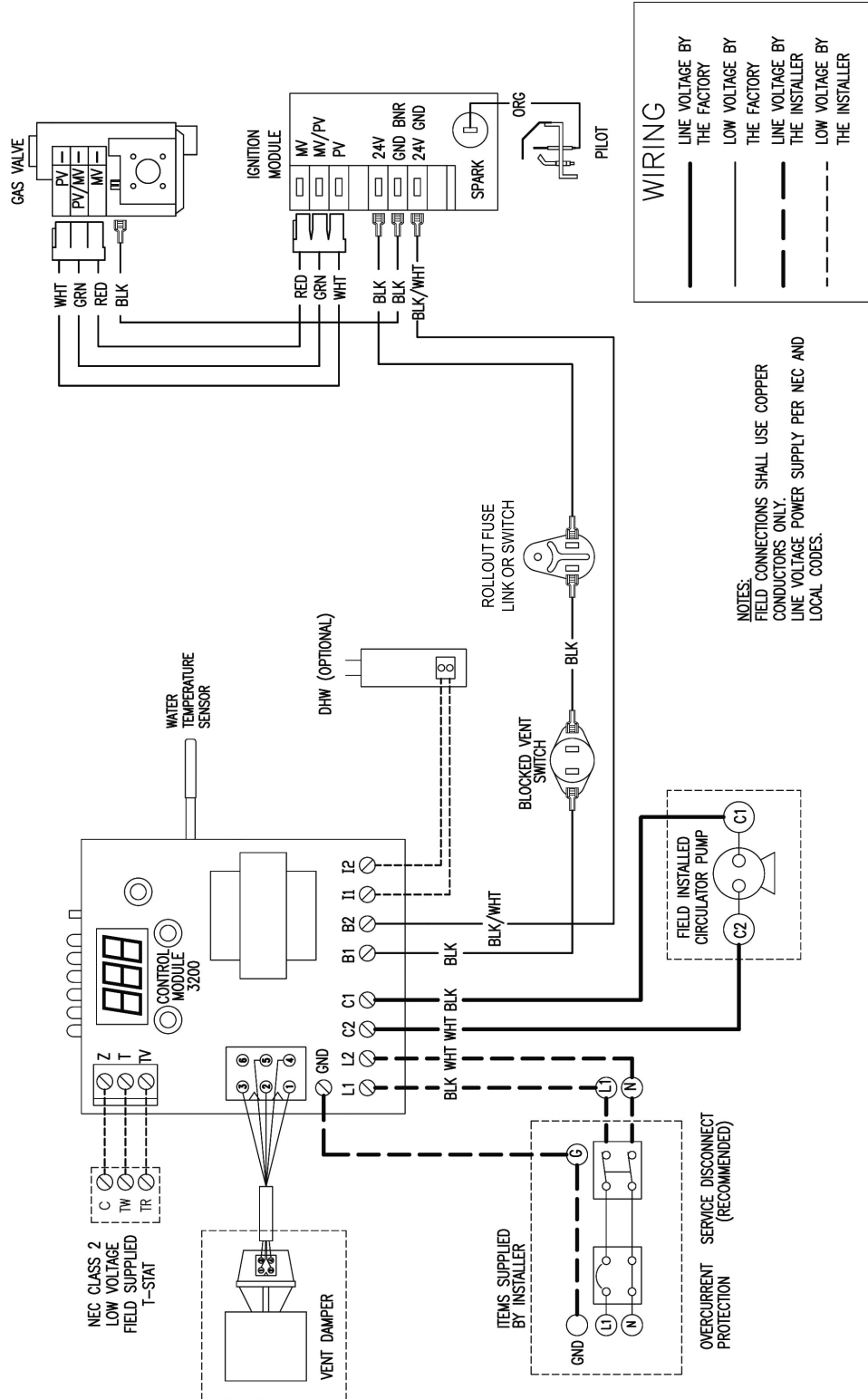

**WARNING**

If you do not follow these instructions exactly, a fire or explosion may result causing property damage, personal injury or loss of life.

- This appliance is equipped with an ignition device which automatically lights burner. **Do NOT try to light this burner by hand.**
- Before operating smell all around appliance area for gas. Be sure to smell next to floor because some gas is heavier than air and will settle to the floor.
- **Use only your hand to turn the gas shutoff valve.** Never use tools. If valve will not turn by hand, do not try to repair it, call a qualified service technician. Force or attempted repair may result in fire or explosion.
- **Do not use this appliance if any part has been under water.** Immediately call a qualified service technician to inspect appliance and to replace any part of control system and any gas control which has been under water.

**NOTICE**

Before lighting any type of pilot burner (standing or intermittent), verify the hot water boiler and system are full of water to minimum pressure of 12 psi in the system, also verify system is vented of air. Set operating control of thermostat to "below" normal setting. Refer to following appropriate lighting instruction.

**LIGHTING PROCEDURE FOR BOILER WITH INTERMITTENT PILOT SYSTEM**

- A. This appliance is equipped with an ignition device which automatically lights the pilot. Do not try to light the appliance by hand.

**CAUTION**

WHAT TO DO IF YOU SMELL GAS

- Do not try to light any appliance.
- Do not touch any electrical switches; do not use any phone in your building.
- Immediately call your gas supplier from a neighbor's phone. Follow the gas supplier's instructions.
- If you cannot reach your gas supplier, call the fire department.

**OPERATING INSTRUCTIONS FOR INTERMITTENT PILOT SYSTEM**

1. STOP! Read the safety information to the left.
2. Set the thermostat to lowest setting.
3. Turn off all electric power to the appliance.
4. This appliance is equipped with an ignition device which automatically lights the pilot. Do not try to light the pilot by hand.

Figure 16 - Intermittent Pilot

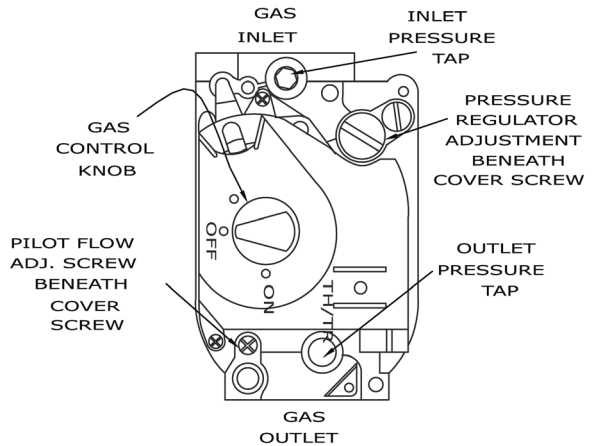

5. Turn the gas control knob counter-clockwise to "OFF."
6. Turn off all electric power to the appliance. Smell for gas around the appliance. If you don't smell gas, go on to the next step.
7. Turn gas control knob counter-clockwise to "ON."
8. Turn on all electric power to the appliance.
9. Set thermostat to desired setting.
10. If the appliance will not operate, follow the instructions "To Turn Off Gas To Appliance", and call qualified service technician or your gas supplier.

**TO TURN OFF GAS TO THE APPLIANCE**

1. Set the thermostat to lowest setting.
2. Turn off all electric power to the appliance if service is to be performed.
3. Push in gas control knob slightly and turn clockwise to "OFF." DO NOT FORCE.
4. Call qualified service technician.

## 12 - NORMAL SEQUENCE OF OPERATION

Thermostat actuates on call for heat, completing circuit to control. Completed circuit to control will first activate circulator and damper which will close end switch inside damper. Completes circuit to ignition system, ignition takes place.

In event boiler water temperature exceeds high limit setting on boiler mounted high limit control, power is interrupted between control system and ignition system. Power remains off until boiler water temperature drops below high limit setting. Circulator continues to operate under this condition until thermostat is satisfied.

In event flow of combustion products through boiler venting system becomes blocked, blocked vent safety switch shuts main burner gas off. Similarly, if boiler flue-way becomes blocked, flame rollout safety switch shuts main burner gas off. Figure 16. If either of these conditions occur, **DO NOT ATTEMPT TO PLACE BOILER BACK INTO OPERATION. CONTACT CERTIFIED SERVICE AGENCY.**

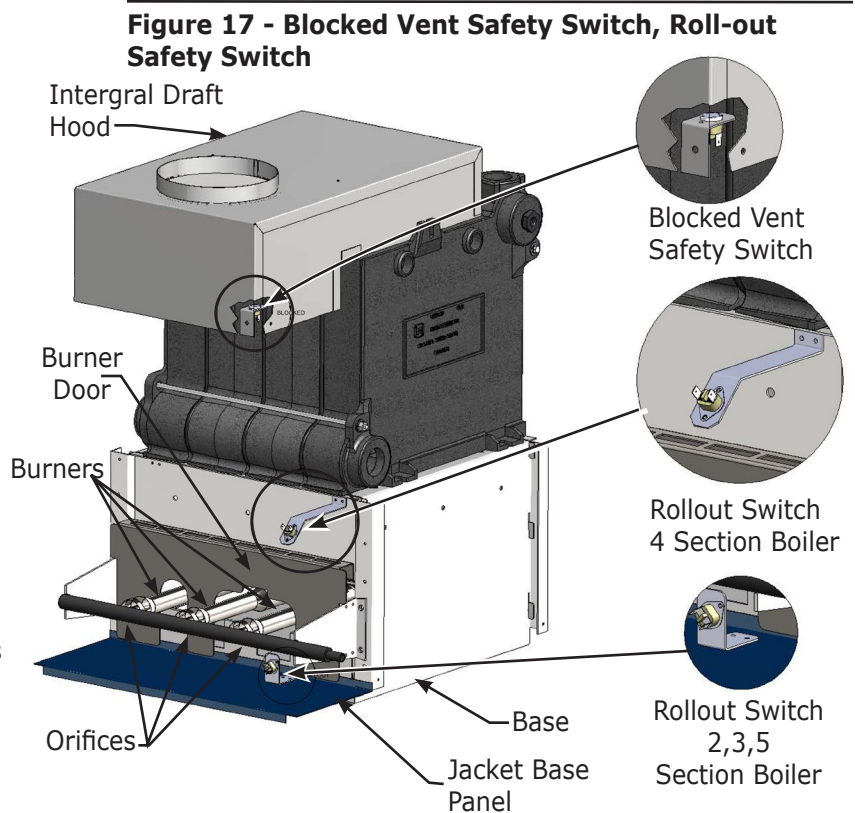

## 13 - GENERAL INSTRUCTIONS

Before seasonal start-up, have a certified service agency check boiler for soot and scale in flues, clean burners and check gas input rate to maintain high operating efficiency.

### **WARNING**

Label all wires prior to disconnection when servicing controls. Wiring errors could cause improper and dangerous operation.

Verify proper operation after servicing. Service agency will verify system is filled with water to minimum pressure and open air vents, if used, to expel any air accumulated in the system. Check entire piping system and, if any leaks appear, have them repaired.

**Circulators need to be checked and maintained. Refer to circulator manufacturer's instructions.**

Inspect venting system at the start of each heating season. Check vent pipe from boiler to chimney for signs of deterioration by rust or sagging joints. Repair if necessary. Remove vent pipe at base of chimney or flue and using a mirror, check vent for obstruction and verify vent is in good working order.

Boiler flue gas passageways may be inspected by a light and mirror. Remove burner door. Figure 17. Place trouble lamp in flue collector through draft relief opening. With mirror positioned above burners, flue gas passageways can be checked for soot or scale.

This procedure should be followed to clean flue gas passageways:

1. Remove burners from combustion chamber by raising burners up from manifold orifices and pulling toward front of boiler. Figure 19.
2. Disconnect vent pipe from draft hood.
3. Remove top jacket panel.
4. Remove combination flue collector and draft hood from boiler castings by loosening nuts on hold down bolts located on each side of collector. Figure 17.
5. Place sheet of heavy paper or similar material over bottom of base and brush down flue passageways. Soot and scale will collect on paper and is easily removed with the paper.
6. With paper still in place in base, clean top of boiler castings of boiler putty or silicone used to seal between castings and flue collector. Verify chips are not lodged in flue passageways.

When cleaning process is complete, restore boiler components to their original position. Use IS-808 GE silicone (available from distributor) to seal around flue collector and boiler castings.

## 13 - GENERAL INSTRUCTIONS

**Figure 18 - Gas Burner Flame**

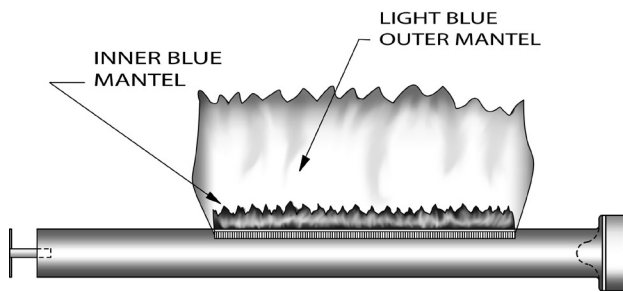

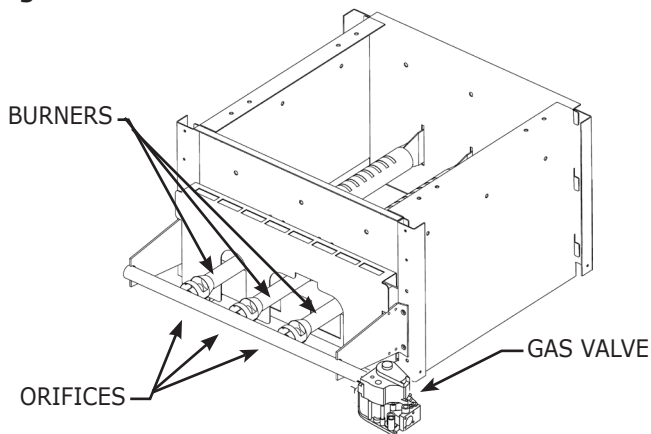

**Figure 19 - Combustion Chamber**

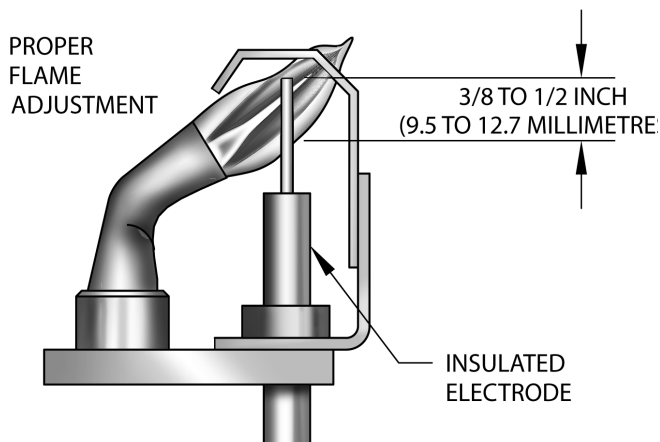

**Figure 20 - Gas Burner Pilot**



- Make visual inspection of main burner and pilot flames at start of heating season and again in mid-season. Main burner flame should have well defined inner blue mantel with lighter blue outer mantel. Check burner throats and burner orifices for lint or dust obstruction. Figures 18 and 19.
- Pilot flame should envelop  $\frac{3}{8}$  to  $\frac{1}{2}$  inch of tip of ignition/sensing electrode. See Figure 20.
- To adjust pilot flame, remove pilot adjustment cover screw and turn inner adjustment screw counterclockwise  to increase or clockwise  to decrease pilot flame. Be sure to replace cover screw after adjustment to prevent possible gas leakage. See Figure 16, Page 19.
- Check burners and pilot for signs of corrosion, rust or scale buildup.
- Area around boiler must be kept clear and free of combustible materials, gasoline and other flammable vapors and liquids.
- Free flow of combustion and ventilating air to boiler and boiler room must not be restricted or blocked.
- Inspect field sourced low water cutoffs annually, or as recommended by low water cutoff manufacturer. Flush float type low water cutoffs per manufacturer's instructions.
- Employ a qualified service agency to make annual inspection of boiler and heating system. They are experienced in making the inspections outlined above, and, in event repairs or corrections are necessary, trained technicians make the proper changes for safe operation of the boiler.

## 14 - CHECKING GAS INPUT RATE TO BOILER





- Adjust gas input to boiler by removing protective cap on pressure regulator, and turning screw clockwise  to increase input and counterclockwise  to decrease input.
- Manifold pressures are taken at outlet side of gas valve.
- To check for proper flow of natural gas to boiler, divide input rate shown on rating plate by heating value of gas obtained from local gas company. This determines number of cubic feet of gas required per hour.
- With all other gas appliances off, determine flow of gas through meter for two minutes and multiply by 30 to get hourly rate.
- Make minor adjustments to gas input as described above. See Figure 16 page 18.
- Change burner orifices if final manifold pressure varies more than plus or minus 0.3 inches water column from specified pressure listed on boiler rating plate.
- Primary air adjustment is not necessary, therefore air shutters are not furnished as standard equipment.

Figure 21 - High Limit Control Location

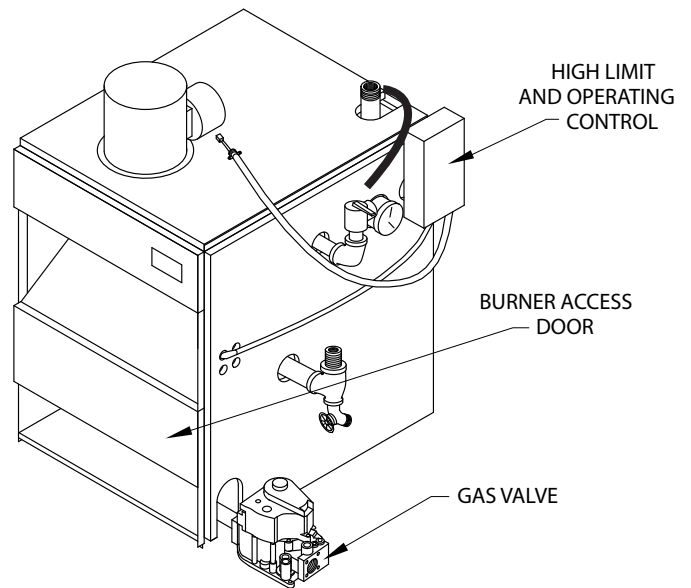

**CHECK SAFETY CONTROL CIRCUIT.** Test ignition system safety shutoff device after placing boiler in operation. Figure 15 page 19.

- 1. Intermittent Pilot:** With main burner operating, turn pilot gas adjusting screw clockwise  until pilot gas is turned off. Within 90 seconds main gas control closes, shutting off gas to main burner.
- 2. High Limit Control:** Remove plastic cover and note temperature setting. Refer to appendix A for adjustment procedure. Decrease setting to minimum and operate boiler. When boiler water temperature exceeds control temperature setting, control will open circuit, closing automatic main gas valve. Figure 21.

- 1 **HI TEMP** illuminates when boiler water temperature reaches high limit setting and remains lit until water temperature falls 10°. Prevents burner operation while this LED is on.
- 2 **LWCO Active** Indicates low water cut-off (LWCO) function of limit control is active. When control is installed with a well, LED is on at all times when control is powered.  
Important: If control is installed with a well other than Electro-Well, LED will not illuminate indicating control is not providing low water cut-off functionality.

### **WARNING**

Burn and scald hazard. Do not add water until boiler has fully cooled. Failure to follow these instructions could result in death or serious injury.

- 3 **LWCO Low Water** illuminates if boiler is in low water condition. Limit control prevents burner operation during this condition.  
**Important:** Have system checked by qualified service agency prior to resuming operation.
- 4 **ECONOMY Active** Indicates thermal targeting function is active and limit control is reducing boiler temperature to conserve fuel. Economy feature is activated using Economy dial.
- 5 **ECONOMY TARGET** Economy feature is active, limit control continually sets target temperatures below high limit setting to maximize fuel efficiency. When boiler water reaches target temperature, LED illuminates and burner shuts down. Boiler water will continue to circulate and heat the house as long as thermostat call continues. LED will stay lit until boiler temperature drops below differential set point at which point boiler will be allowed to fire again.

Note: LED illuminates regularly during normal boiler operation.

- 6 **LWCO TEST** Button  
To Test Low Water Cut-Off: Press and hold Test/Settings button for 5 seconds. Display will read LWCO.  
LWCO TEST *LCO*  
Red Low Water light will illuminate and burner circuit (B1 and B2) will de-energize.  
Note: Control must be installed with Electro-Well for low water cut-off functionality.







## **IMPORTANT**

In accordance with Section 325 (f) (3) of the Energy Policy and Conservation Act, this boiler is equipped with a feature that saves energy by reducing the boiler water temperature as the heating load decreases.

This feature is equipped with an override which is provided primarily to permit the use of an external energy management system that serves the same function.

**THIS OVERRIDE MUST NOT BE USED UNLESS AT LEAST ONE OF THE FOLLOWING CONDITIONS IS TRUE:**

- An external energy management system is installed that reduces the boiler water temperature as the heating load decreases.
- This boiler is not used for any space heating
- This boiler is part of a modular or multiple boiler system having a total input of 300,000 BTU/hr or greater.
- This boiler is equipped with a tankless coil.



**PRODUCT LITERATURE**

Lennox Industries Inc.  
Dallas, Texas