

Datasheet

Part numbers and prices: see pricelist

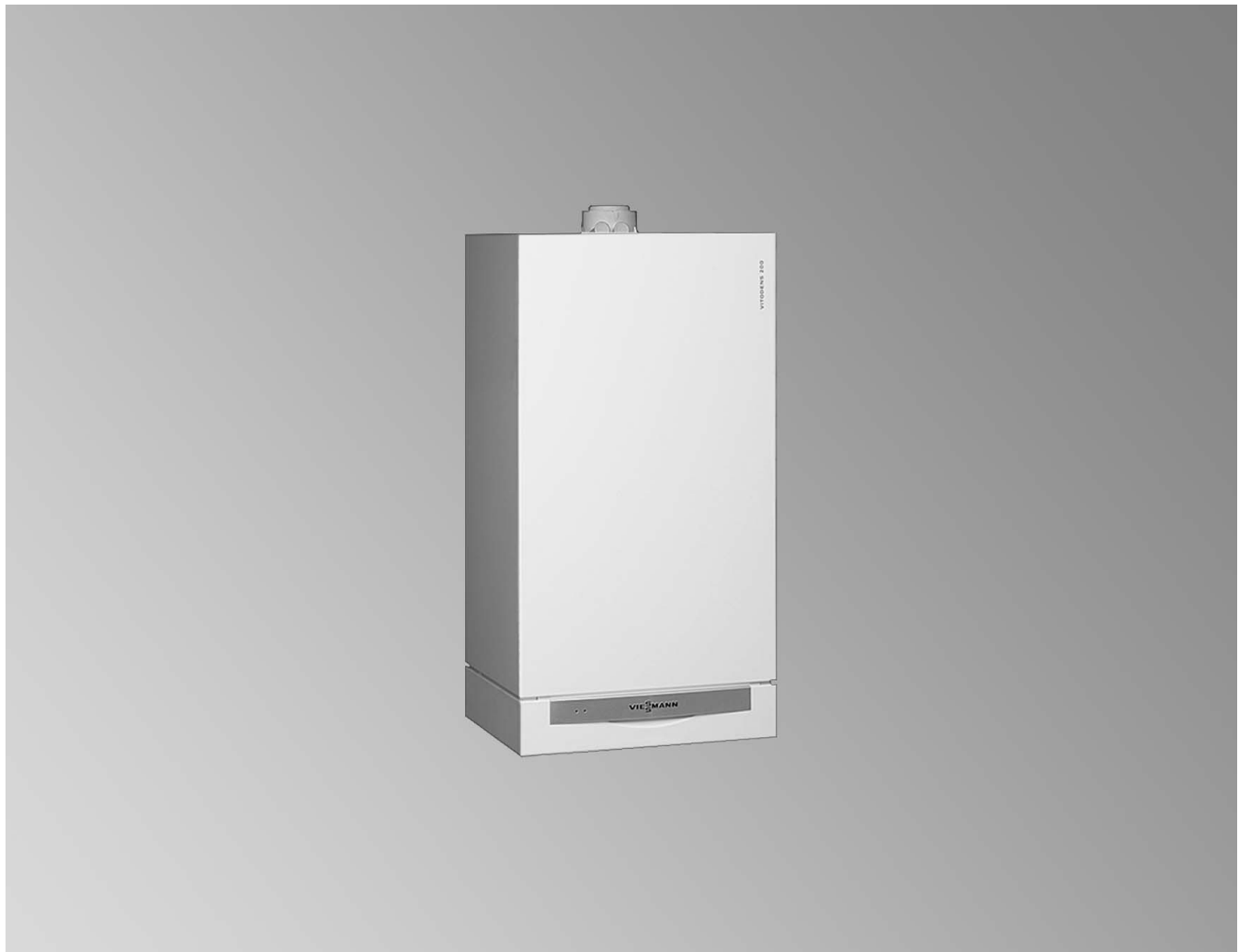

File in:
Vitotec folder, register 7



VITODENS 200-W Type WB2B

Wall mounted gas fired condensing boiler,
with modulating Matrix cylinder burner,
for open or balanced flue operation
For natural gas and LPG

Product description

A superb blend of top technology:

The modulating MatriX cylinder burner and the proven stainless steel Inox-Radial heat exchanger ensure a standard efficiency of up to 98 % (H_s)/109 % (H_i). That reduces heating costs and protects the environment.

Like all wall mounted condensing boilers from Viessmann, the Vitodens 200-W too is equipped with a stainless steel Inox-Radial heat exchanger. That brings with it all the benefits offered by its heat transfer principle, its design and its high self-cleaning effect.

With its modulation range of 1:4, the MatriX cylinder burner saves energy and reduces emissions. Its extremely clean combustion lets it perform substantially better than the limits set for the "Blue Angel" certificate of environmental excellence.

The Vitodens 200-W is equipped with the intelligent Lambda Pro Control combustion controller. That guarantees permanently optimised combustion.

The combi version of the Vitodens 200-W is equipped with a plate-type heat exchanger. That delivers DHW immediately at a constant outlet temperature – without delay.

Benefits at a glance

- Wall mounted gas fired condensing boiler as central heating or combi boiler.
- Standard efficiency: up to 98 % (H_s)/109 % (H_i)
- Wide modulation range of 1:4
- Stainless steel Inox-Radial heat exchanger
 - Self-cleaning of the smooth stainless steel surfaces through the flue gas and the condensate flowing in the same direction
 - Excellent corrosion resistance through high-grade stainless steel 1.4571
- Modulating MatriX cylinder burner – in-house development and manufacture
 - Clean combustion
 - Long service life through stainless steel MatriX mesh
 - Optimised match between the heat exchanger and the burner
- High DHW convenience – condensing combi boilers; generally with standby function
- Lambda Pro Control combustion controller
 - A change in the gas type requires no change of nozzle
 - Consistently high efficiency, even in case of fluctuating gas composition and air pressure
 - Consistently low emissions
 - Low combustion noise through low fan speed

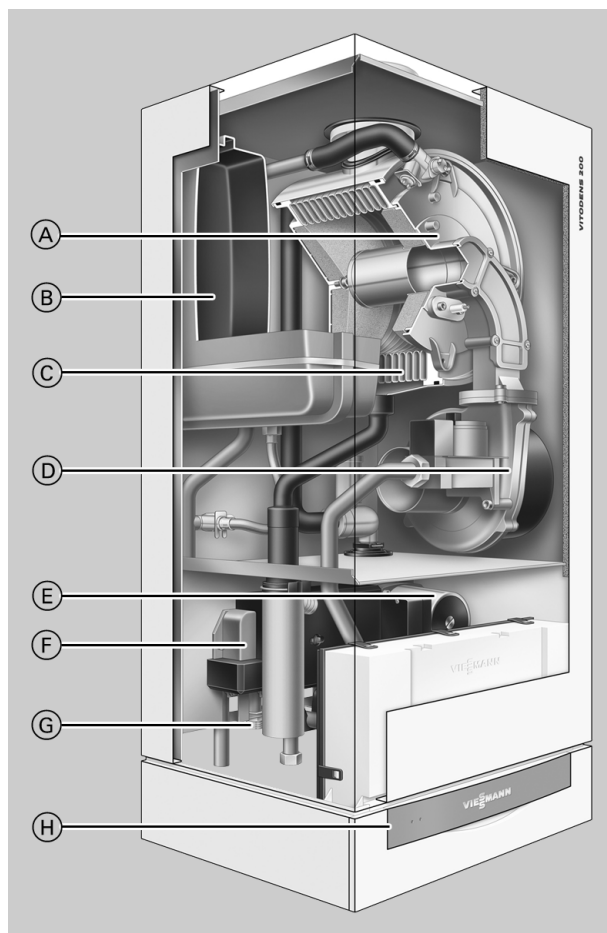

- (A) Modulating MatriX cylinder burner with intelligent Lambda Pro Control combustion controller for clean combustion and quiet operation
- (B) Integral diaphragm expansion vessel
- (C) Inox-Radial heating surfaces made from stainless steel - for high operational reliability, a long service life and high output on the smallest footprint
- (D) Variable speed combustion fan for quiet and economical operation
- (E) Integral two-stage circulation pump
- (F) Plate-type heat exchanger (for gas fired condensing combi boiler, 6.5 to 35 kW)
- (G) Gas and water connections
- (H) Digital boiler control unit

Specification

Specification

Gas fired boiler, series B and C, Category II _{2N3P}		Gas fired boiler			Gas fired combi boiler	
Rated output range*1						
$T_V/T_R = 50/30\text{ °C}$	kW	4.8-19.0	6.5-26.0	8.8-35.0	6.5-26.0	8.8-35.0
$T_V/T_R = 80/60\text{ °C}$	kW	4.3-17.2	5.9-23.7	8.0-31.7	5.9-23.7	8.0-31.7
Rated output range for DHW heating						
	kW	–	–	–	5.9-29.3	8.0-35.0
Rated thermal load						
	kW	4.5-17.9	6.2-24.7	8.3-33.0	6.2-30.5	8.3-36.5
Product ID		CE-0085 BR 0432				
Protection		IP X4D to EN 60529				
Gas supply pressure						
Natural gas	mbar	20	20	20	20	20
LPG	mbar	50	50	50	50	50
Max. permissible gas supply pressure*2						
Natural gas	mbar	25.0	25.0	25.0	25.0	25.0
LPG	mbar	57.5	57.5	57.5	57.5	57.5
Power consumption						
	W	85	95	115	95	115
Weight						
	kg	43	45	47	46	48
Content, heat exchanger						
	l	1.8	2.4	2.8	2.4	2.8
Max. flow rate						
	l/h	1200	1400	1600	1400	1600
(limit for the use of hydraulic separation)						
Nominal circulation water volume						
	l/h	739	1018	1361	1018	1361
at $T_V/T_R = 80/60\text{ °C}$						
Diaphragm expansion vessel						
Capacity	l	10	10	10	10	10
Inlet pressure	bar	0.8	0.8	0.8	0.8	0.8
Permissible operating pressure						
	bar	3	3	3	3	3
Safety valve connection						
	Rp	¾"	¾"	¾"	¾"	¾"
Dimensions						
Length	mm	360	360	360	360	360
Width	mm	450	450	450	450	450
Height	mm	850	850	850	850	850
Height with flue outlet bend	mm	1066	1066	1066	1066	1066
Height with DHW cylinder, below	mm	1925	1925	1925	–	–
Gas connection						
	R	½"	½"	½"	½"	½"
Standby instantaneous water heater						
Hot and cold water connections	G	–	–	–	½"	½"
Permiss. operating pressure (DHW side)	bar	–	–	–	10	10
Minimum pressure, cold water connection	bar	–	–	–	1.0	1.0
Outlet temperature, adjustable	°C	–	–	–	30-57	30-57
Continuous DHW output	kW	–	–	–	29.3	35.0
Specific throughput	l/min	–	–	–	13.9	16.7
at $\Delta T = 30\text{ K}$ (to DIN EN 13203)						
Connection values						
relative to the max. load						
with gas						
Natural gas E	m ³ /h	1.89	2.61	3.48	3.23	3.86
Natural gas LL	m ³ /h	2.20	3.04	4.10	3.75	4.49
LPG	kg/h	1.40	1.93	2.57	2.38	2.85

*1 Details to EN 677.

*2 If the gas supply pressure is higher than the maximum permitted value, install a separate gas pressure governor upstream of the system.

Specification (cont.)

Gas fired boiler, series B and C, Category II _{2N3P}		Gas fired boiler			Gas fired combi boiler	
Rated output range*1						
$T_V/T_R = 50/30\text{ °C}$	kW	4.8-19.0	6.5-26.0	8.8-35.0	6.5-26.0	8.8-35.0
$T_V/T_R = 80/60\text{ °C}$	kW	4.3-17.2	5.9-23.7	8.0-31.7	5.9-23.7	8.0-31.7
Flue gas parameters*2						
Flue gas value group to G 635/G 636		G ₅₂ /G ₅₁	G ₅₂ /G ₅₁	G ₅₂ /G ₅₁	G ₅₂ /G ₅₁	G ₅₂ /G ₅₁
Temperature (at return temperature 30 °C)						
– at rated output	°C	45	45	45	45	45
– at partial load	°C	35	35	35	35	35
Temperature (at return temperature 60 °C)						
– at rated output	°C	68	70	70	70	70
Mass flow rate						
Natural gas						
– at rated output	kg/h	33.3	47.3	63.2	47.3	70.0
– at partial load	kg/h	8.4	11.8	15.7	11.8	15.7
LPG						
– at rated output	kg/h	32.5	46.4	62.0	46.4	68.2
– at partial load	kg/h	8.2	11.5	15.4	11.5	15.4
Available delivery pressure						
	Pa	100	100	100	100	100
	mbar	1.0	1.0	1.0	1.0	1.0
Standard efficiency		up to 98 (H _s)/109 (H _i)				
at $T_V/T_R = 40/30\text{ °C}$		%				
Average amount of condensate						
for natural gas and						
$T_V/T_R = 50/30\text{ °C}$	l/day	10-12	11-13	15-17	11-13	15-17
Internal pipe diameter to the safety valve		DN	15	15	15	15
Condensate connection (hose nozzles)		Ø mm	20-24	20-24	20-24	20-24
Flue gas connection		Ø mm	60	60	60	60
Ventilation air inlet		Ø mm	100	100	100	100

*1 Details to EN 677.

*2 Calculation values for sizing the flue gas system to EN 13384.

Flue gas temperatures measured as gross values at 20 °C combustion air temperature.

The flue gas temperature at a return temperature of 30 °C is significant for the sizing of the flue gas system.

The flue gas temperature at a return temperature of 60 °C is used to determine the application range of flue pipes with max. permissible operating temperatures.

Specification (cont.)

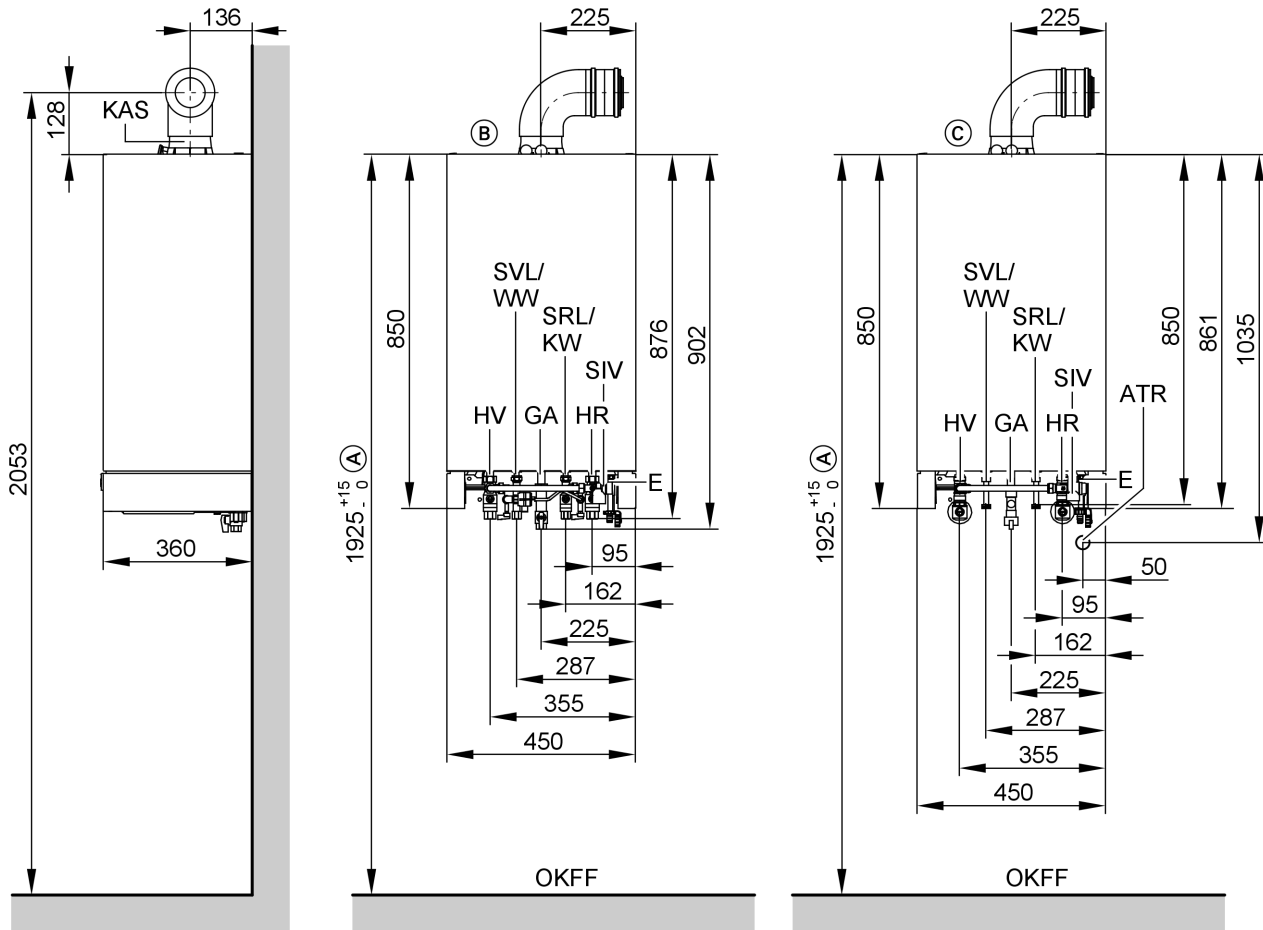

- (A) Compulsory in conjunction with DHW cylinders, below, otherwise recommendation only.
- (B) Installation on finished walls
- (C) Installation on unfinished walls
- ATR Drain outlet connection
- E Drain
- GA Gas connection
- HR Heating return

- HV Heating flow
- KAS Boiler flue connection
- KW Cold water (gas fired combi boiler)
- OKFF Top edge finished floor
- SIV Safety valve
- SRL Cylinder return (gas fired boiler)
- SVL Cylinder flow (gas fired boiler)
- WW DHW (gas fired combi boiler)

Note

For connection dimensions for installation on finished walls with installation aid, see page 7.

For connection dimensions for installation on unfinished walls with installation aid, see page 10.

Note

Prepare all connections on site before commencing the boiler installation.

Route all required supply cables on site and lead them into the boiler at the point indicated (see page 12).

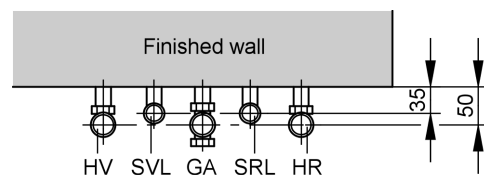

Two-stage heating circuit pump in the Vitodens 200-W

Rated boiler output		kW	4.8 - 19.0	6.5 - 26.0	8.8 - 35.0
Type			VI RLE-40	VI RLE-50	VI RLE-70
Rated voltage		V~	230	230	230
Rated current	min.	A	0.20	0.27	0.35
	max.	A	0.26	0.31	0.40
Power consumption	Stage 1	W	45	60	75
	Stage 2	W	60	70	90

Specification (cont.)

Residual head of the integral circulation pump

Vitodens 200-W, 4.8 - 19.0 kW

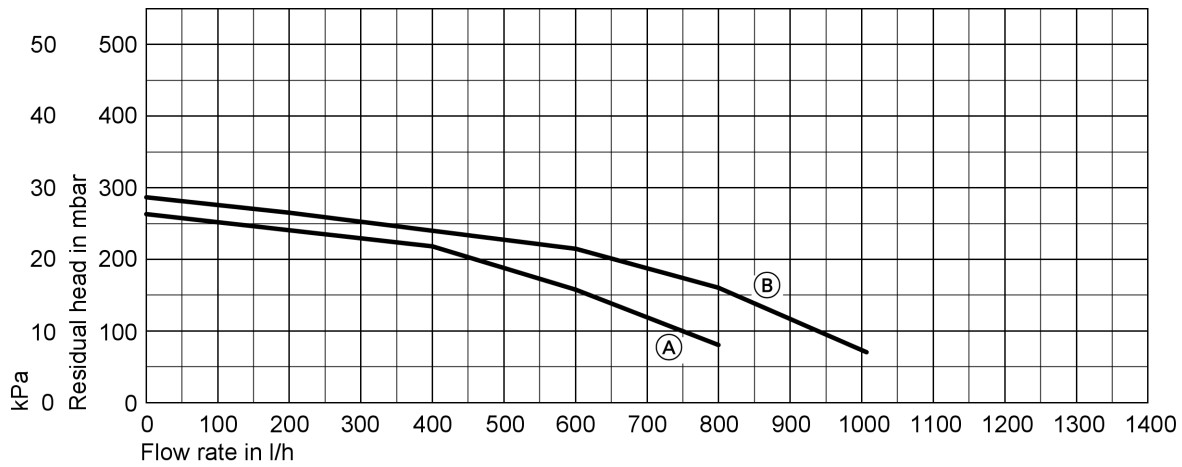

- Ⓐ Stage 1
- Ⓑ Stage 2

Vitodens 200-W, 6.5 - 26.0 kW

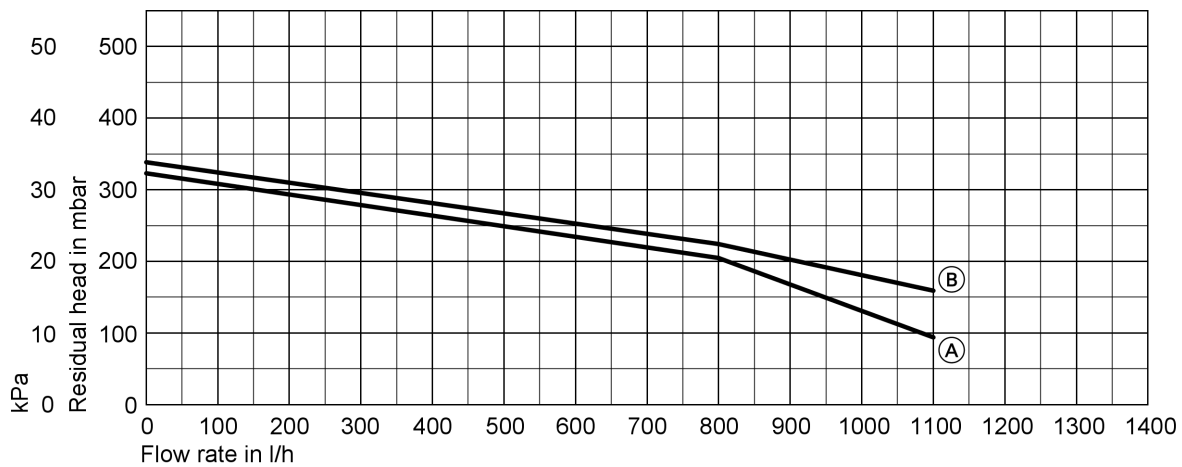

- Ⓐ Stage 1
- Ⓑ Stage 2

Specification (cont.)

Vitodens 200-W, 8.8 - 35.0 kW

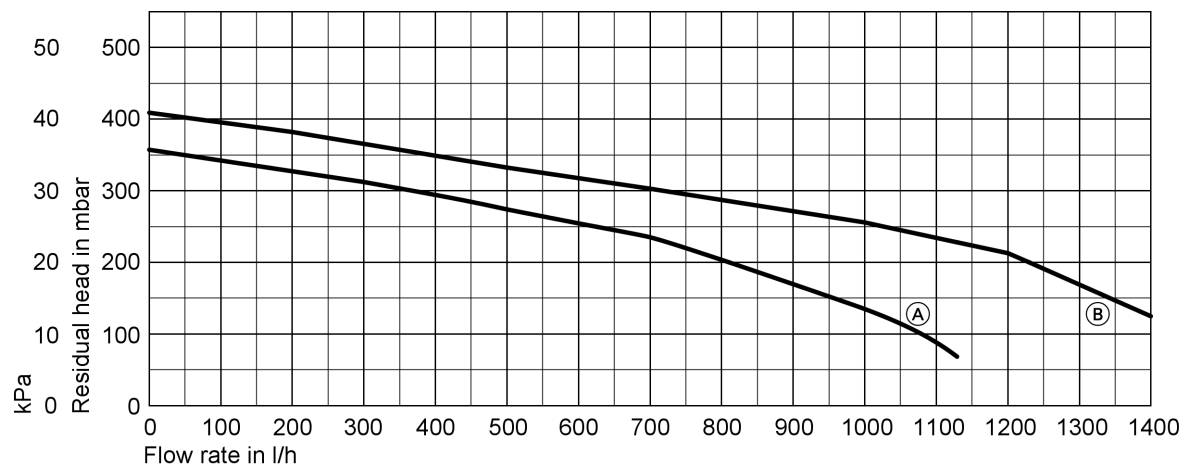

- (A) Stage 1
- (B) Stage 2

DHW heating with DHW cylinders

DHW cylinders, see the separate datasheets.
DHW cylinders in white are also available in the following versions:

- Vitocell 100-W to 400 litre
- Vitocell 300-W to 200 litre

All other DHW cylinders are available in Vitosilver.

Pre-assembly

Clearances for maintenance work

Ensure a clearance of 700 mm in front of the Vitodens or the DHW cylinder and 350 mm above the Vitodens for the removal of the expansion vessel. Maintenance clearances to the left or right of the Vitodens are **not** required.

Pre-installation for mounting the Vitodens 200-W directly on the wall – installation on finished walls

Accessories required for installations without DHW cylinder

Installation aid

with fixing parts, valves and gas tap Rp ½" with integral thermally activated safety shut-off valve

Additional requirements when connecting a DHW cylinder
Connection set for DHW cylinders

Pre-assembly (cont.)

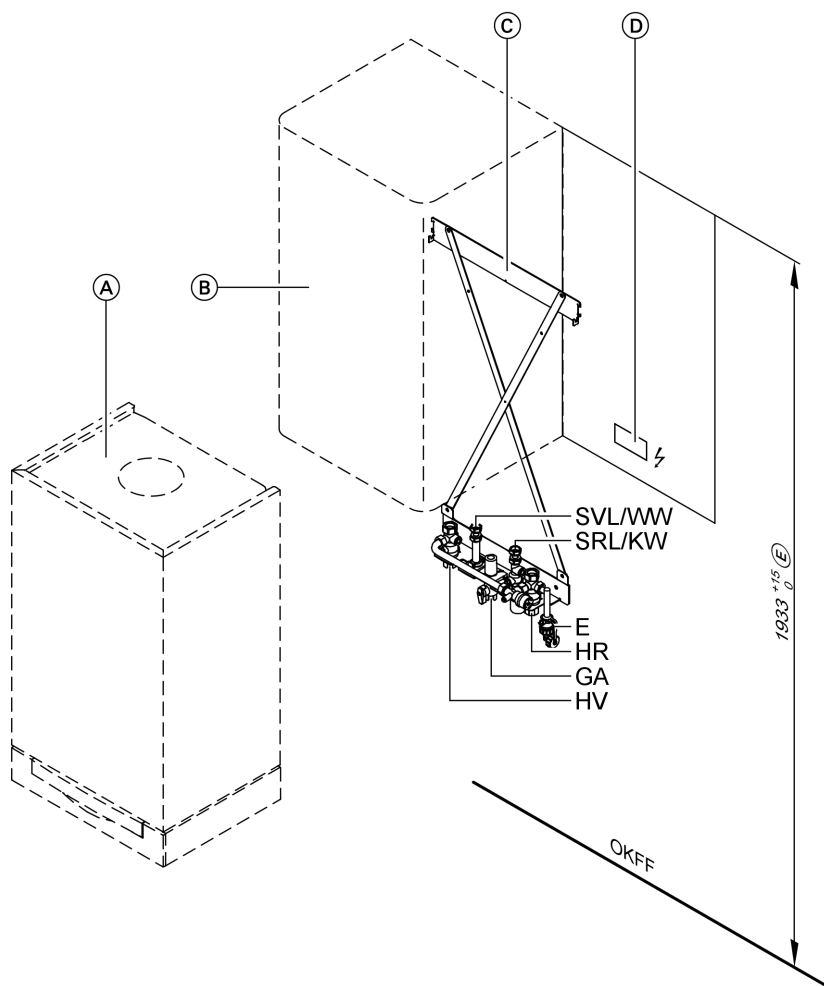

- | | | | |
|---|--------------------------------------------------------------------------------------------|------|---------------------------------------------|
| Ⓐ | Vitodens | GA | Gas connection Rp 1/2" |
| Ⓑ | DHW cylinder mounted on the wall (if installed) | HR | Heating return Rp 3/4" |
| Ⓒ | Installation aid | HV | Heating flow Rp 3/4" |
| Ⓓ | Area for power cables.
Allow all cables/leads to protrude approx. 800 mm from the wall. | KW | Cold water Rp 1/2" (gas fired combi boiler) |
| Ⓔ | Compulsory in conjunction with DHW cylinders below, otherwise, recommendation only. | OKFF | Top edge, finished floor |
| E | Drain | WW | DHW Rp 1/2" (gas fired combi boiler) |
| | | SRL | Cylinder return G 3/4" (gas fired boiler) |
| | | SVL | Cylinder flow G 3/4" (gas fired boiler) |

Pre-installation with the sub-mounting kit with mixer – installation on finished walls

Accessories required:

■ Sub-mounting kit:

With a plate-type heat exchanger, circulation pump, three-way mixer, bypass, mixer electronics, flow temperature sensor, cover and installation template

■ Installation aid:

With fixing parts, valves and gas tap Rp 1/2" with integral thermally activated safety shut-off valve

■ Connection set for DHW cylinders (if installed)

May **not** be used in conjunction with the DHW cylinder Vitocell 100-W, below.

For further details regarding accessories for the sub-mounting kit, see page 34.

Pre-assembly (cont.)

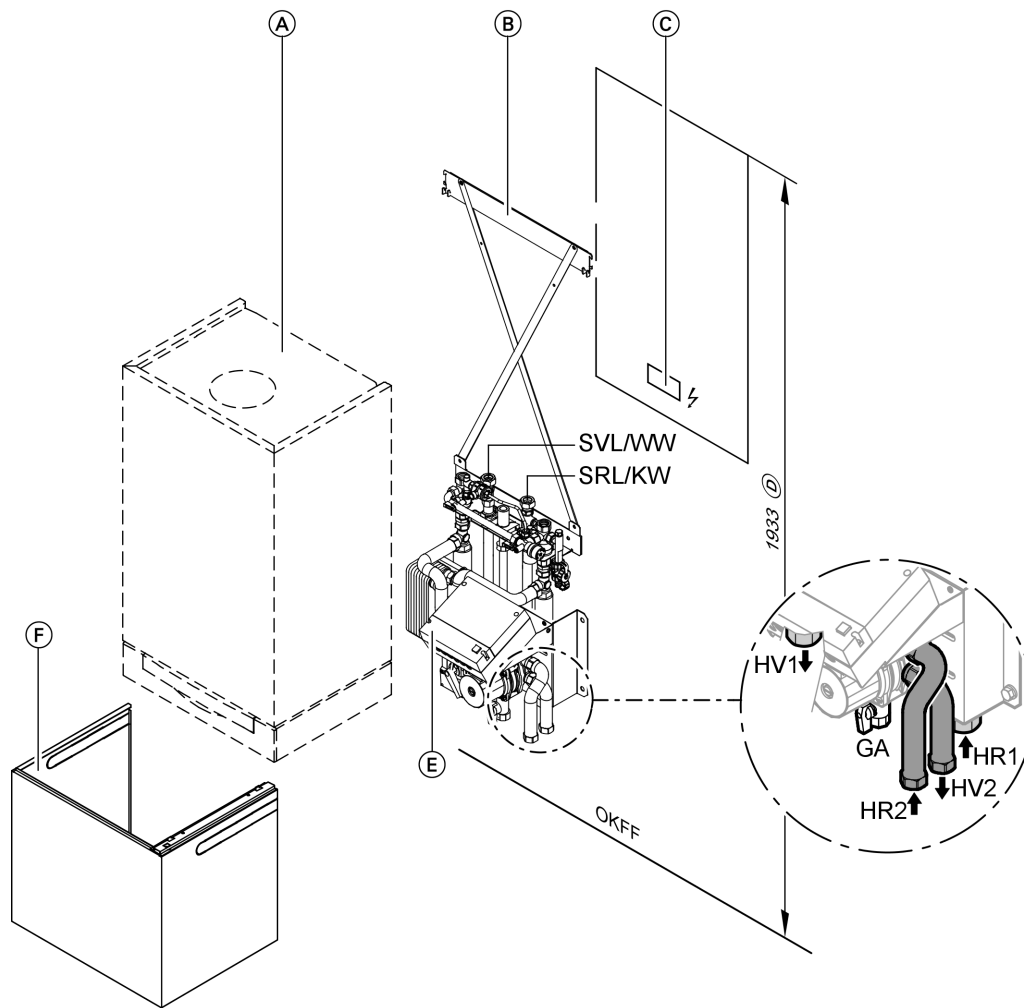

- | | | | |
|-----|--------------------------------------------------------------------------------------------|------|------------------------------------------------------|
| (A) | Vitodens | HR1 | Heating return, heating circuit without mixer G 3/4" |
| (B) | Installation aid | HR2 | Heating return, heating circuit with mixer G 3/4" |
| (C) | Area for power cables.
Allow all cables/leads to protrude approx. 800 mm from the wall. | HV1 | Heating flow, heating circuit without mixer G 3/4" |
| (D) | Recommendation | HV2 | Heating flow, heating circuit with mixer G 3/4" |
| (E) | Sub-mounting kit | KW | Cold water G 1/2" (gas fired combi boiler) |
| (F) | Cover | OKFF | Top edge, finished floor |
| GA | Gas connection R 1/2" | WW | DHW G 1/2" (gas fired combi boiler) |
| | | SRL | Cylinder return G 3/4" (gas fired boiler) |
| | | SVL | Cylinder flow G 3/4" (gas fired boiler) |

Pre-installation for mounting the Vitodens 200-W directly on the wall – installation on unfinished walls

Accessories required for installations without DHW cylinder

Installation aid

with fixing parts, valves and gas tap R 1/2" with integral thermally activated safety shut-off valve

Additional requirements when connecting a DHW cylinder

Connection set for DHW cylinders

Pre-assembly (cont.)

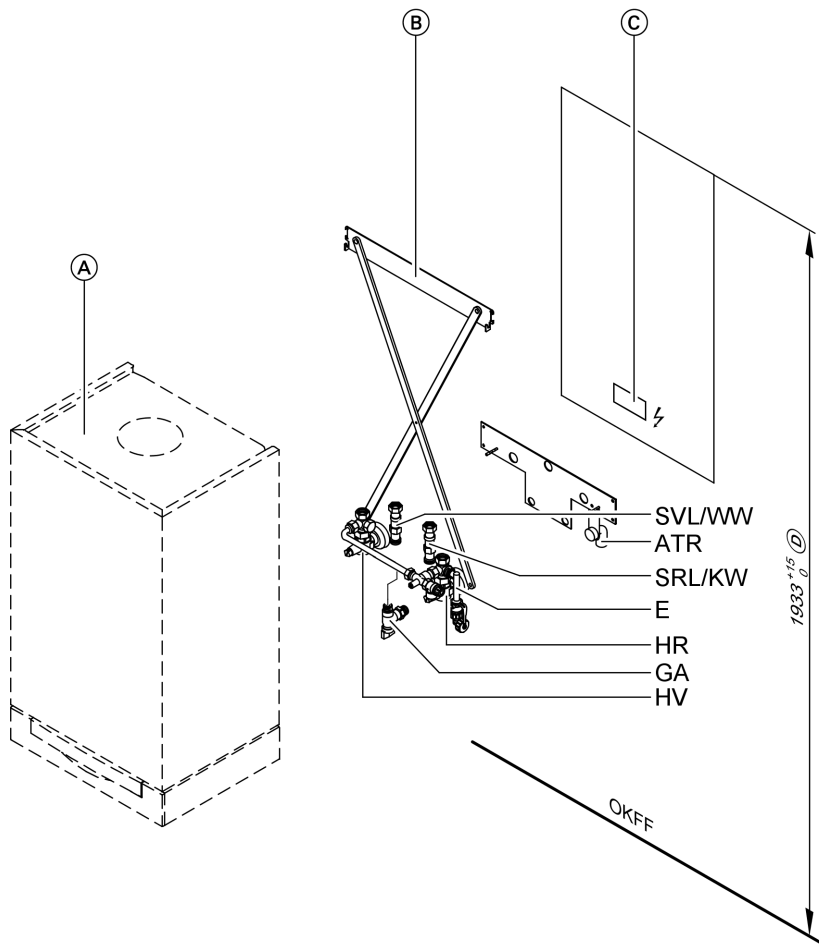

Illustration: Gas fired boiler connections

- | | | | |
|-----|--------------------------------------------------------------------------------------------|------|------------------------------------------|
| Ⓐ | Vitodens | GA | Gas connection R ½" |
| Ⓑ | Installation aid | HR | Heating return G ¾" |
| Ⓒ | Area for power cables.
Allow all cables/leads to protrude approx. 800 mm from the wall. | HV | Heating flow G ¾" |
| Ⓓ | Compulsory in conjunction with DHW cylinders below, otherwise, recommendation only. | KW | Cold water G ½" (gas fired combi boiler) |
| ATR | Drain outlet connection R 1" | OKFF | Top edge, finished floor |
| E | Drain | WW | DHW G ½" (gas fired combi boiler) |
| | | SRL | Cylinder return G ¾" (gas fired boiler) |
| | | SVL | Cylinder flow G ¾" (gas fired boiler) |

Self-supporting installation

Self-supporting mounting frame

for Vitodens and wall mounted DHW cylinder (80 litre capacity). Suitable for wall mounting, for self-supporting installation or for covering.

With valves with threaded fittings and gas angle valve G ¾" with thermally activated safety shut-off valve.

- For gas fired combi boiler
- For gas fired boiler

Pre-assembly (cont.)

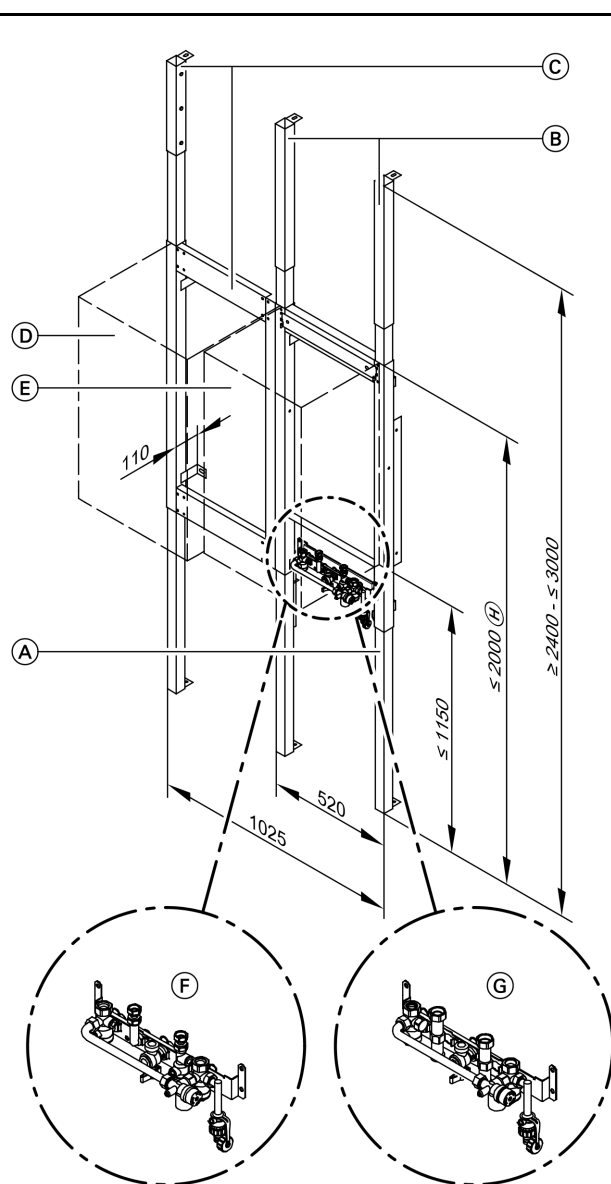

- Ⓒ Self-supporting mounting frame for wall mounted DHW cylinders incl. ceiling mounting extension
- Ⓓ Wall mounted DHW cylinder (80 litre capacity)
- Ⓔ Vitodens
- Ⓕ Gas fired combi boiler connection panel
- Ⓖ Gas fired boiler connection panel
- Ⓗ In conjunction with DHW cylinders below, min. 1933 mm

Note

For connection dimensions for installation on finished walls, see page 7.

- Ⓐ Self-supporting mounting frame for the Vitodens with connection panel
- Ⓑ Ceiling mounting extension (Vitodens)

Electrical connection

Electrical connection

Ensure the power connection complies with the requirements of your local power supply utility and current VDE [or local] regulations.

Protect the power cable with a fuse with a maximum rating of 16 A.

Provide the power supply (230 V~/50 Hz) via a permanent connection.

Connect the supply cables and accessories at the terminals inside the boiler.

Pre-assembly (cont.)

Power supply of accessories

The power supply of accessories can be connected directly to the control unit. This connection is controlled with the system ON/OFF switch (max. 4 A).

Where the boiler is installed in a wet area, do not connect the power supply of accessories at the control unit.

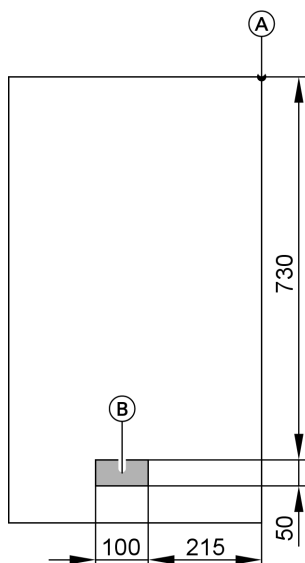

Ⓐ Reference point, Vitodens top edge

Ⓑ Area for power cables

Allow cables in the shaded area (see drawing) to protrude at least 800 mm from the wall.

Recommended leads/cables

NYM-J 3 × 1.5 mm ²	2-core min. 0.75 mm ²	NYM-O 3 × 1.5 mm ²
<ul style="list-style-type: none"> - Power supply cables (also for accessories) - DHW circulation pump - Central fault message 	<ul style="list-style-type: none"> - External extension H1 or H2 - Outside temperature sensor - Vitotronic 200-H (LON) - Extension kit for heating circuit with mixer (KM BUS) - Vitotrol 100, type UTD - Vitotrol 200 - Vitotrol 300 - Radio clock receiver 	<ul style="list-style-type: none"> - Vitotrol 100, type UTA

Interlock switch

Install an interlock for open flue operation if an extractor (e.g. cooker hood) is fitted in the room providing the boiler ventilation. For this, the internal extension H2 (accessories) can be used. This switches the extractors OFF when the burner is started.

Vitodens 200-W as a replacement for third party boilers

Using an adaptor, the Vitodens may be connected to the water connections of Ceramini-Z-SR, Cerastar-ZR/-ZWR and Thermo-block-VC110E-/VC112E-/VC/-VCW boilers.

For modernisation, adaptors with connection components for the heating water and DHW sides and fixing components for the replacement of the following third party equipment with a Vitodens are available as accessories (see pricelist).

Replacing these devices with the Vitodens will not lead to a greater installation effort than for the original equipment.

Generally, where a conventional gas fired boiler is replaced by a Vitodens 200-W gas fired condensing boiler, the flue must be replaced with a flue that is suitable for "condensing operation" (see pricelist for "flue gas systems for the Vitodens"). Match up the flue connections on site.

Note

For modernising projects, the State Building Regulations [Germany] require the installation of a gas tap with thermally activated shut-off valve.

Vitodens 200-W as a replacement for third party boilers (cont.)

Replacing a Ceramini-Z-SR with a Vitodens 200-W, 4.8 to 19 kW

Open flue operation

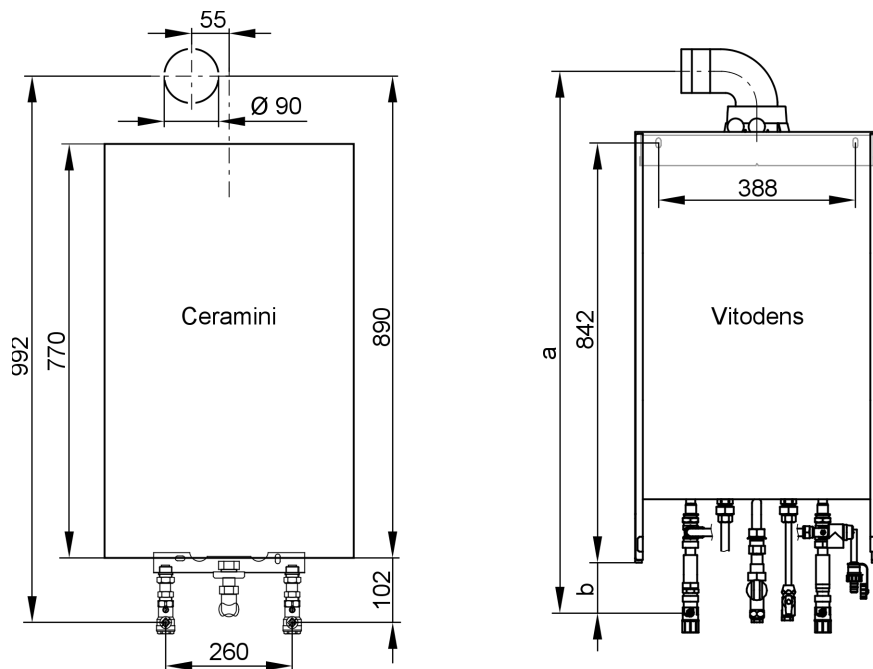

Dimensions	Installation on unfinished walls	Installation on finished walls
a mm	1098	1086
b mm	127	115

Balanced flue operation

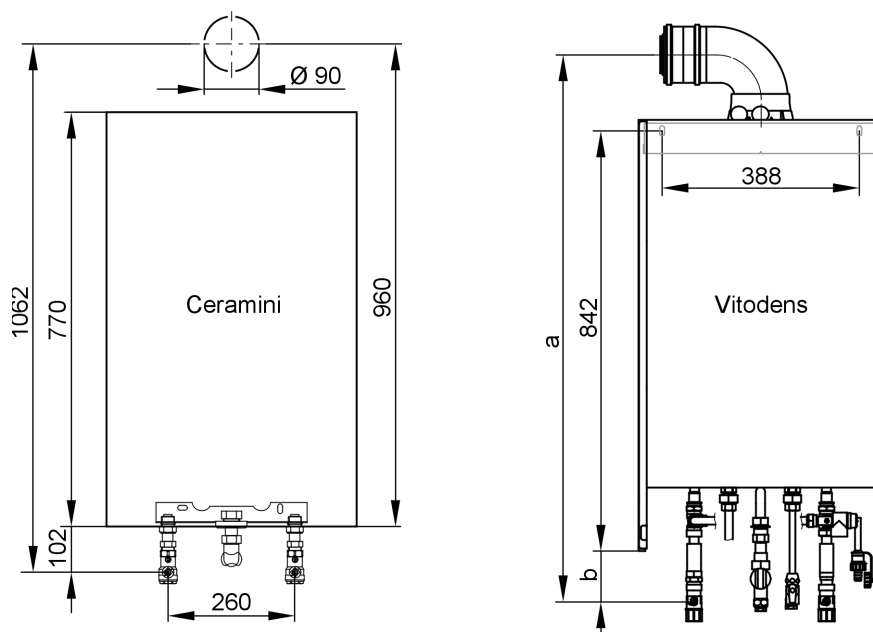

Vitodens 200-W as a replacement for third party boilers (cont.)

Dimensions		Installation on unfinished walls	Installation on finished walls
a	mm	1105	1093
b	mm	127	115

Existing water connections have identical dimensions.
The parts marked in grey (incl. mounting rail) in the following diagrams are part of the standard delivery.

Installation on unfinished walls

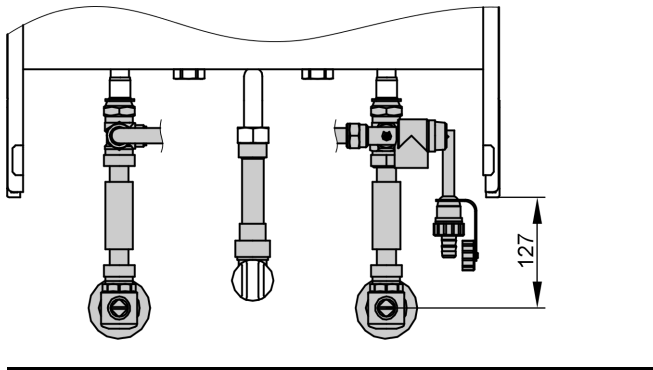

Installation on finished walls

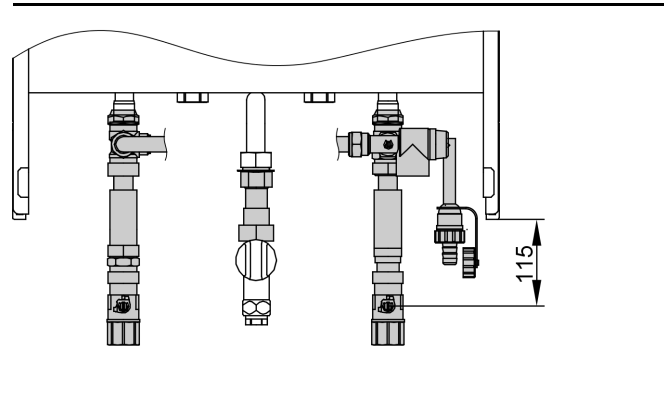

Replacing a Cerastar-ZR/-ZWR with a Vitodens 200-W, 6.5 to 35 kW

Open flue operation

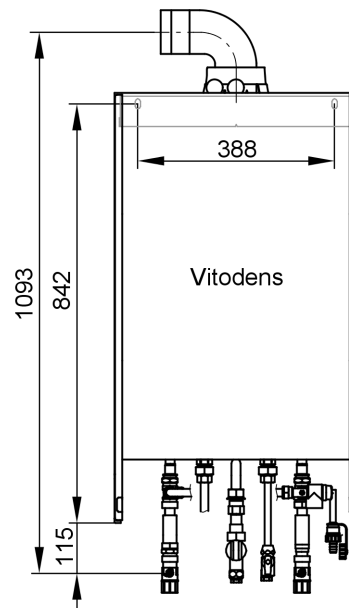
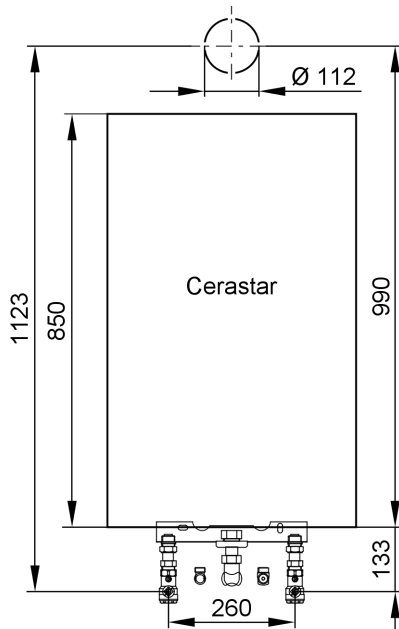

Vitodens 200-W as a replacement for third party boilers (cont.)

Balanced flue operation

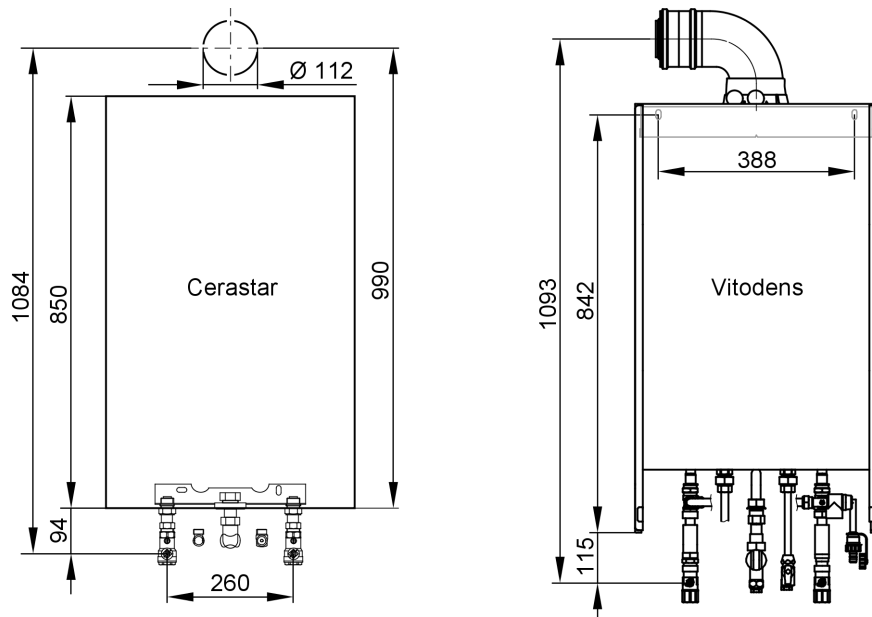

Existing water connections have identical dimensions. The parts marked in grey (incl. mounting rail) in the following diagrams are part of the standard delivery.

Installation on unfinished walls

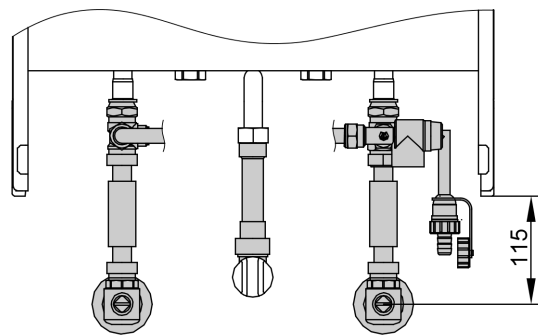

Gas fired boiler

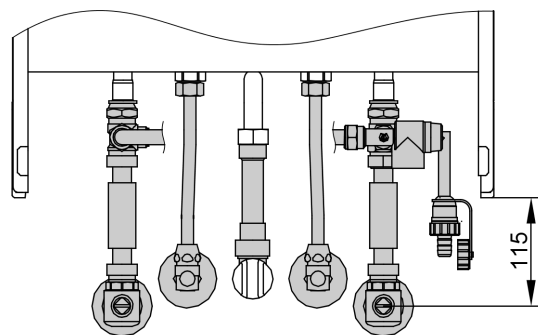

Gas fired combi boiler

Installation on finished walls

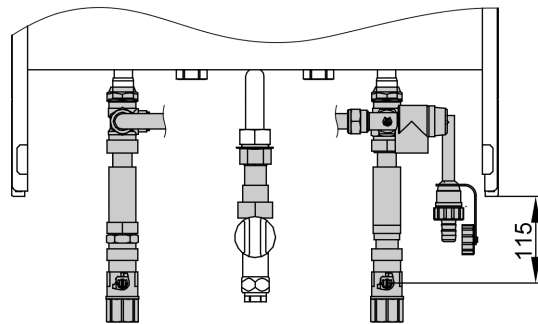

Gas fired boiler

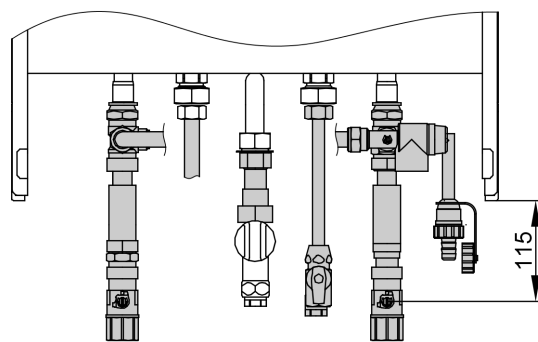

Gas fired combi boiler

Vitodens 200-W as a replacement for third party boilers (cont.)

Replacing a Thermoblock-VC110E/-VC112E with a Vitodens 200-W, 4.8 to 19 kW

Open flue operation

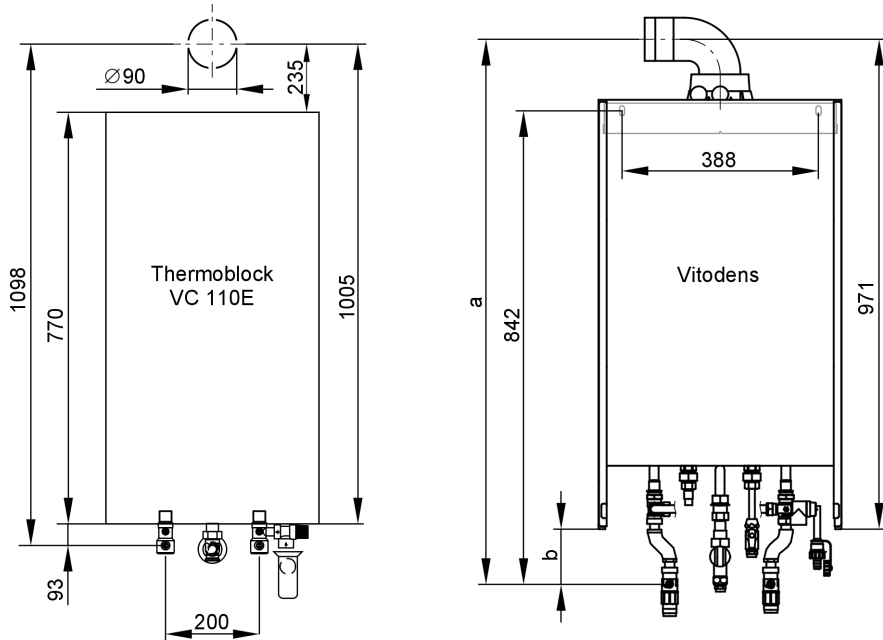

Dimensions	Installation on unfinished walls	Installation on finished walls
a mm	1037	1076
b mm	66	105

Balanced flue operation

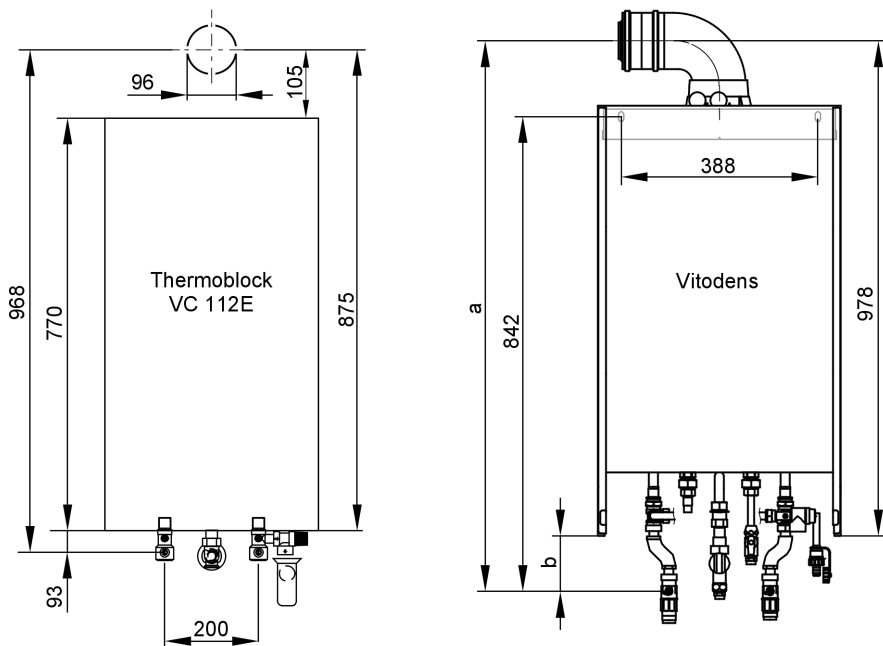

Dimensions	Installation on unfinished walls	Installation on finished walls
a mm	1044	1083
b mm	66	105

5822 376 GB

Vitodens 200-W as a replacement for third party boilers (cont.)

Existing water connections have identical dimensions.

The parts marked in grey (incl. mounting rail) in the following diagrams are part of the standard delivery.

Installation on unfinished walls

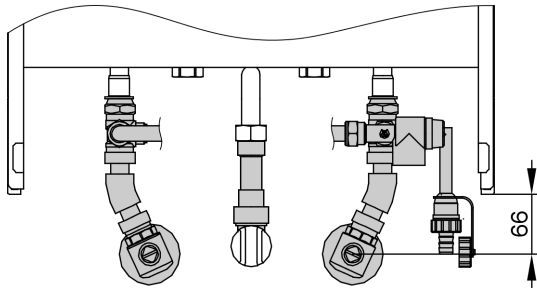

Installation on finished walls

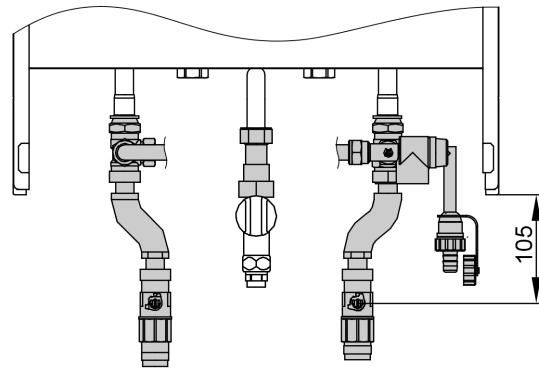

Replacing a Thermoblock-VC/-VCW with a Vitodens 200-W, 6.5 to 35 kW

Open flue operation

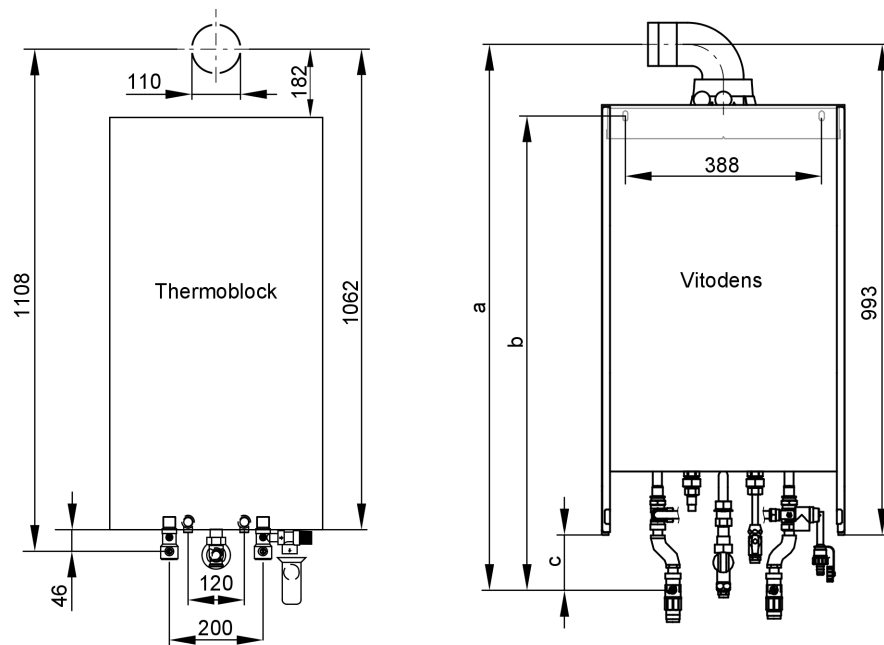

Vitodens 200-W as a replacement for third party boilers (cont.)

Balanced flue operation

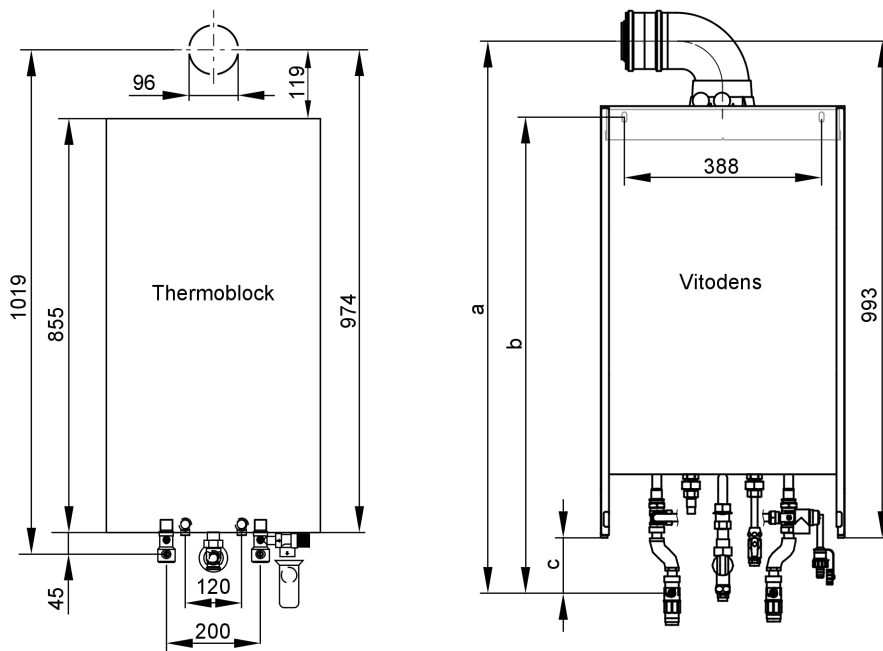

Dimensions	Installation on unfinished walls	Installation on finished walls
a mm	1044	1083
b mm	908	947
c mm	66	105

Existing water connections have identical dimensions.

The parts marked in grey (incl. mounting rail) in the following diagrams are part of the standard delivery.

Installation on unfinished walls

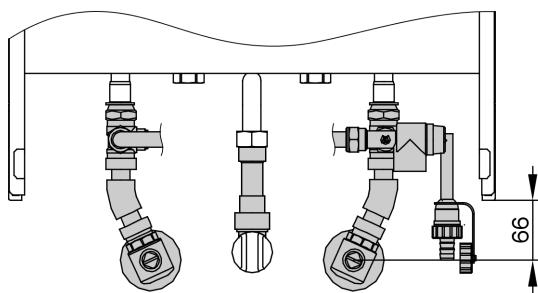

Gas fired boiler

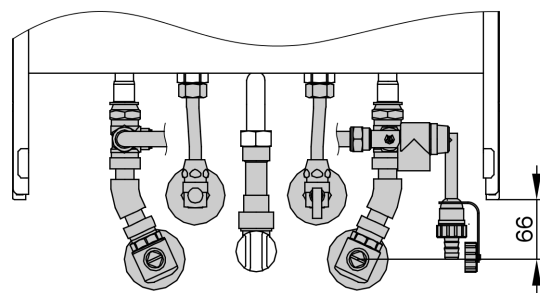

Gas fired combi boiler

Vitodens 200-W as a replacement for third party boilers (cont.)

Installation on finished walls

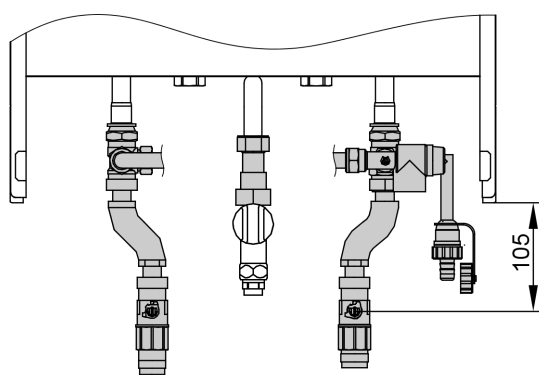

Gas fired boiler

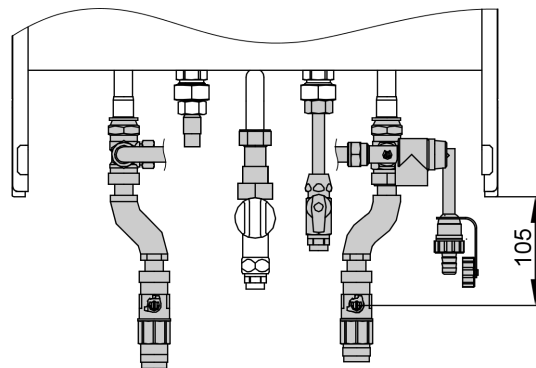

Gas fired combi boiler

Vitotronic 100, type HC1, for constant temperature operation

Structure and functions

Modular construction

The control unit is integrated into the Vitodens.
The control unit comprises a standard unit, electronic modules and a programming unit.

Standard unit:

- ON/OFF switch
- Optolink laptop interface
- Operating and fault display
- Reset button
- Fuses

Programming unit:

- Display
- Adjustment and display of temperatures and codes
- Fault message display
- Keys:
 - Program selection
 - Boiler water temperature
 - DHW temperature
 - DHW convenience function
 - Emissions test function

Functions

- Electronic boiler control unit for operation at a constant boiler water temperature
- Room temperature-dependent operation requires a Vitotrol 100, type UTA or UTD (according to EnEV [Germany])
- Heating system frost protection
- Integral diagnostic system
- Integral cylinder thermostat

Control characteristics

PI characteristics with modulating output.

Setting the heating programs

The heating system frost protection (see frost protection function) applies to all heating programs.

You can select the following heating programs with the program keys:

- Heating and DHW
- DHW only
- Standby mode

Frost protection

The burner is switched ON when the boiler water temperature reaches 5 °C and will be switched OFF again, when the boiler water temperature reaches 20 °C.

The circulation pump will be switched ON simultaneously with the burner and switched OFF after a delay.

The DHW cylinder will be heated to approx. 20 °C.

To protect the system against frost, the circulation pump may be started at certain intervals (up to 24 times per day) for periods of approx. 10 minutes.

Summer mode

Heating program "☀"

The burner starts only when the cylinder needs reheating or when DHW is drawn from a combi boiler.

Boiler water temperature sensor

The boiler water temperature sensor is connected to the control unit and built into the boiler.

Specification

Permissible ambient temperature

– during operation	0 to +130 °C
– during storage and transport	-20 to +70 °C

Cylinder temperature sensor

Standard delivery for:

- Connection set for wall mounted DHW cylinders (80 litre) (order separately)
- Connection set for DHW cylinders, below (120 or 150 litre) (order separately)
- Connection set for DHW cylinders, adjacent (160 to 400 litre) or alternative DHW cylinders (order separately)

Specification

Cable length	3.75 m, fully wired
Protection	IP 32
Permissible ambient temperature	
– during operation	0 to +90 °C
– during storage and transport	-20 to +70 °C

Vitotronic 100, type HC1, for constant temperature operation (cont.)

Specification, Vitotronic 100, type HC1

Rated voltage	230 V~	Electronic temperature limiter setting (heating mode)	82 °C (change not possible)
Rated frequency	50 Hz	Setting range for the DHW temperature	
Rated current	6 A	– Gas fired combi boiler:	10 to 57 °C
Protection class	I	– Gas fired boiler:	10 to 63 °C
Function	Type 1 B to EN 60730-1		
Permissible ambient temperature			
– during operation	0 to +40 °C		
	Installation in living spaces or boiler rooms (standard ambient conditions)		
– during storage and transport	-20 to +65 °C		

Accessories for the Vitotronic 100

Vitotrol 100, type UTA

Part no. 7170 149

Room thermostat

- With switching output (two-point output)
- With analog time switch
- With adjustable individual day program
- Standard switching times are factory-set (individually programmable)
- Shortest switching interval 15 minutes

Install the Vitotrol 100 in the main living room on an internal wall opposite radiators, but not inside shelf units, recesses, immediately by a door or a heat source (e.g. direct sunlight, fireplace, TV set, etc.).

Control unit connection:

3-core cable with a cross-section of 1.5 mm² (without green/yellow) for 230 V~.

Specification

Rated voltage	230 V/50 Hz
Rated breaking capacity of the contact	6(1) A 250 V~
Protection	IP 20 to EN 60529 safeguard through appropriate design and installation
Permissible ambient temperature	
– during operation	0 to +40 °C
– during storage and transport	-20 to +60 °C
Set value range for standard and reduced mode	10 to 30 °C
Set room temperature in standby mode	6 °C

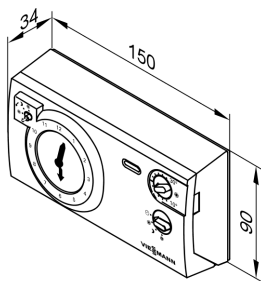

Vitotrol 100, type UTD

Part no. 7179 059

Room thermostat

- With switching output (two-point output)
- With digital time switch
- With individual day and 7-day programs
- With rotary selector for the following settings:
 - Standard room temperature "Permanent comfort"
 - Reduced room temperature "Permanent setback"
 - Frost protection temperature "Frost"
 - 2 fixed time programs
 - 1 individually adjustable time program
 - Holiday program
- With selector keys for party and economy mode

Install the Vitotrol 100 in the main living room on an internal wall opposite radiators, but not inside shelf units, recesses, immediately by a door or a heat source (e.g. direct sunlight, fireplace, TV set, etc.).

Operation without power supply (two 1.5 V round alkaline cells, type LR6 (AA), which run for approx. 18 months)

Control unit connection:

2-core cable with a cross-section of 1.5 mm² for 230 V~
Connection via a LV cable is possible in conjunction with the external extension H4 (accessories).

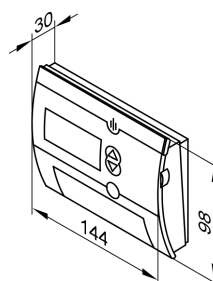

Accessories for the Vitotronic 100 (cont.)

Specification

Rated voltage	3 V-
Rated breaking capacity of the zero volt contact	
– max.	6(1) A 230 V~
– min.	1 mA 5 V-
Protection	IP 20 to EN 60529 safeguard through appropriate design and installation
Function	RS type 1B to EN 60730-1

Permissible ambient temperature	
– during operation	0 to +50 °C
– during storage and transport	-10 to +60 °C
Setting range	
– Comfort temperature	10 to 30 °C
– Setback temperature	10 to 30 °C
– Frost temperature	6 to 10 °C
Power reserve during battery change	10 min

External extension H4

Part no. 7197 227

Connection extension for connecting the Vitotrol 100, type UTD or 24 V clock thermostats via a LV cable.
With cable (0.5 m long) and plug for the connection to the Vitotronic 100.

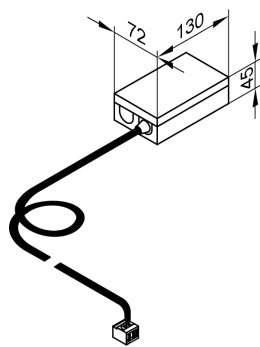

Specification

Rated voltage	230 V~
Output voltage	24 V~
Rated frequency	50 Hz
Power consumption	2.5 W
Load 24 V~ (max.)	10 W
Protection class	I
Protection	IP 41
Permissible ambient temperature	
– during operation	0 to +40 °C Installation in living spaces or boiler rooms (standard ambient conditions)
– during storage and transport	-20 to +65 °C

Vitocom 100, type GSM

- Without SIM card
Part no. Z004594
- With contract SIM card for the operation of the Vitocom 100 via mobile phone
Part no. Z004615

Note

For further information regarding the conditions of contract, see the Viessmann pricelist.

Functions:

- Remote switching via GSM mobile phone networks
- Remote scanning via GSM mobile phone networks
- Remote monitoring via SMS to 1 or 2 mobile phones
- Remote monitoring of additional systems via digital input (230 V)

Configuration:

Mobile phones via SMS

Standard delivery:

- Vitocom 100 (subject to order with or without SIM card)
- Power supply cable with Euro plug (2.0 m long)
- GSM aerial (3.0 m long), magnetic foot and adhesive pad
- KM BUS cable (3.0 m long)

On-site requirements:

Good reception for GSM communication of the selected mobile phone operator.
Total length of all KM BUS subscriber cables up to 50 m.

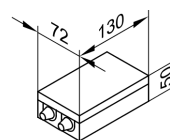

Specification

Rated voltage	230 V ~
Rated frequency	50 Hz
Rated current	15 mA
Power consumption	4 W
Protection class	II
Protection	IP 41 to EN 60529; safeguard through appropriate design and installation
Function	Type 1B to EN 60 730-1
Permissible ambient temperature	
– during operation	0 to +55 °C Installation in living spaces or boiler rooms (standard ambient conditions)
– during storage and transport	-20 to +85 °C
On-site connection	
Fault input DE 1	230 V~

Accessories for the Vitotronic 100 (cont.)

KM BUS distributor

Part no. 7415 028

For the connection of 2 to 9 devices to the Vitotronic KM BUS.

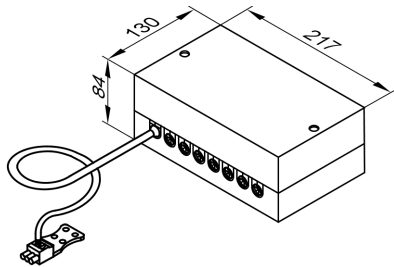

Specification

Lead length	3.0 m, fully wired
Protection	IP 32 to EN 60529; safeguard through appropriate design and installation
Permissible ambient temperature	
– during operation	0 to +40 °C
– during storage and transport	-20 to +65 °C

Internal extensions H1 and H2 and external extensions H1 and H2

For connection options and specifications, see accessories for the Vitotronic 200 from page 30.

Vitotronic 200, type HO1, for weather-compensated operation

Structure and functions

Modular construction

The control unit comprises a standard unit, electronic modules and a programming unit.

All are integrated into the Vitodens.

Standard unit:

- ON/OFF switch
- Optolink laptop interface
- Operating and fault display
- Reset button

Programming unit:

- With digital time switch
- Illuminated display with plain text support
- Adjustment and display of temperatures and codes
- Fault message display
- Rotary selector for the temperature in standard mode
- Keys:
 - Program selection
 - Holiday program
 - Party and economy mode
 - Temperature for reduced mode
 - DHW temperature
 - Emissions test function

Functions

- Weather-compensated control of the boiler water and/or flow temperature
- Electronic maximum temperature limiter
- Demand-dependent heating circuit pump and burner OFF control
- Adjustment of a variable heating limit
- Anti-seizing pump protection
- Maintenance display
- Heating system frost protection
- Integral diagnostic system
- Cylinder temperature control with priority
- Auxiliary function for DHW heating (short-term heating to a higher temperature)
- Adjusting switching times for the DHW circulation pump
- Screed drying program
- External starting and blocking (optional with accessories)

The requirements of DIN EN 12831 for the heating load calculation are met. To reduce the heat-up load, the reduced room temperature will be raised in case of low outside temperatures. The flow temperature will be raised for a limited time to reduce the heat-up time after a setback period.

According to the Energy Savings Order [Germany], the temperature in each room must be individually controlled, e.g. through thermostatic radiator valves.

Control characteristics

PI characteristics with modulating output.

Time switch

Digital time switch

- Individual and 7-day program
- Automatic summer/winter time changeover
- Automatic function for DHW heating and DHW circulation pump
- Time, day and standard switching times for central heating, DHW heating and the DHW circulation pump are factory-set
- Switching times are individually programmable, i.e. up to four switching periods per day

Shortest switching interval: 10 minutes

Power backup: 14 days

Setting the heating programs

The heating system frost protection (see frost protection function) applies to all heating programs.

You can select the following heating programs with the program keys:

- Heating and DHW
- DHW only
- Standby mode

External heating program changeover in conjunction with an external extension H1 or H2.

Vitotronic 200, type HO1, for weather-compensated operation (cont.)

Frost protection

- The frost protection function will be started when the outside temperature drops below approx. +1 °C. With the frost protection function, the heating circuit pump will be switched ON and the boiler water is maintained at a lower temperature of approx. 20 °C. The DHW cylinder will be heated to approx. 20 °C.
- The frost protection function will be stopped when the outside temperature rises above approx. +3 °C.

Summer mode

Heating program "☀"

The burner starts only when the cylinder needs reheating or when DHW is drawn from a combi boiler.

Adjusting the heating curves (slope and level)

The Vitotronic 200 controls the boiler water temperature (= flow temperature of the heating circuit without mixer) and the flow temperature of the heating circuit with mixer (in conjunction with the extension kit for one heating circuit with mixer) subject to outside temperature. The boiler water temperature is automatically boosted by between 0 and 40 K higher than the currently required set flow temperature (delivered condition 8 K).

The flow temperature required to reach a specific room temperature depends on the heating system and the thermal insulation of the building to be heated.

Adjusting both heating curves matches the boiler water temperature and the flow temperature to these operating conditions.

Heating curves:

The upper boiler water temperature is limited by the temperature limiter and the temperature set at the electronic maximum thermostat.

The flow temperature cannot exceed the boiler water temperature.

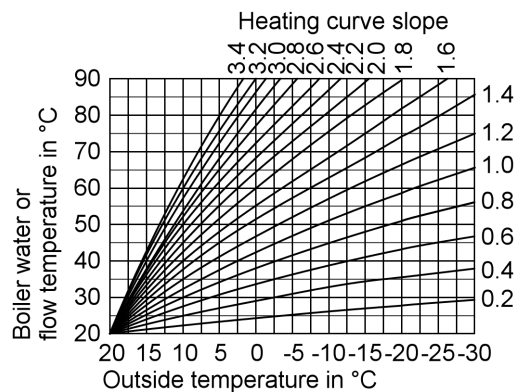

Boiler water temperature sensor

The boiler water temperature sensor is connected to the control unit and built into the boiler.

Specification

Permissible ambient temperature	
– during operation	0 to +130 °C
– during storage and transport	-20 to +70 °C

Cylinder temperature sensor

Standard delivery for:

- Connection set for wall mounted DHW cylinders (80 litre) (order separately)
- Connection set for DHW cylinders, below (120 or 150 litre) (order separately)
- Connection set for DHW cylinders, adjacent (160 to 400 litre) or alternative DHW cylinders (order separately)

Specification

Cable length	3.75 m, fully wired
Protection	IP 32
Permissible ambient temperature	
– during operation	0 to +90 °C
– during storage and transport	-20 to +70 °C

Outside temperature sensor

Installation location:

- North or north-western wall of the building
- 2 to 2.5 m above the ground, for multi-storey buildings in the upper half of the second floor

Connection:

- 2-core lead, length up to 35 m with a cross-section of 1.5 mm² (copper)
- Never route this lead immediately next to 230/400 V cables

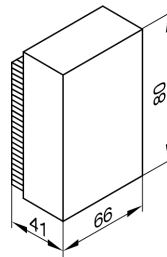

Specification

Protection	IP 43 to EN 60529; safeguard through appropriate design and installation
------------	--------------------------------------------------------------------------

Permissible ambient temperature during operation, storage and transport	-40 to +70 °C
-------------------------------------------------------------------------	---------------

Heating systems with low loss header

When using a hydraulic separation (low loss header), connect a temperature sensor for use in the low loss header (see the Vitodens technical guide).

Specification, Vitotronic 200, type HO1

Rated voltage	230 V~
Rated frequency	50 Hz
Rated current	6 A
Protection class	I
Permissible ambient temperature	
– during operation	0 to +40 °C
	Installation in living spaces or boiler rooms (standard ambient conditions)

– during storage and transport	-20 to +65 °C
Electronic temperature limiter setting (heating mode)	82 °C (change not possible)
Setting range for the DHW temperature	
Gas fired combi boiler	10 to 57 °C
Gas fired boiler	10 to 63 °C

Vitotronic 200, type HO1, for weather-compensated operation (cont.)

Heating curve setting range	Level	-13 to 40 K
Slope	0.2 to 3.5	

Accessories for the Vitotronic 200

Information regarding room temperature hook-up (RS function) for remote control units

Due to the "inertia" of underfloor heating systems, the RS function should not be applied to an underfloor heating circuit. The RS function must only affect the heating circuit with mixer.

Information regarding the Vitotrol 200 and 300

For every heating circuit in a heating system, one Vitotrol 200 or one Vitotrol 300 can be deployed.

Vitotrol 200

Part no. 7450 017

KM BUS subscriber

The Vitotrol 200 remote control regulates the heating program for one heating circuit and the required set room temperature in standard mode, from any room in the house.

The Vitotrol 200 is equipped with backlit heating program selection keys as well as a party and economy key.

The fault display shows faults on the control unit.

WS function:

Installation anywhere in the building.

RS function:

Installation in the main living room on an internal wall opposite radiators. Never install inside shelf units, recesses, immediately by a door or heat source (e.g. direct sunlight, fireplace, TV set, etc.).

The integral room temperature sensor captures the actual room temperature and effects any necessary correction of the flow temperature as well as a rapid heat-up at the start of the heating operation (if appropriately programmed).

Connection:

- 2-core lead, length max. 50 m (even if connecting several remote control units)
- Never route this lead immediately next to 230/400 V cables
- LV plug part of the standard delivery

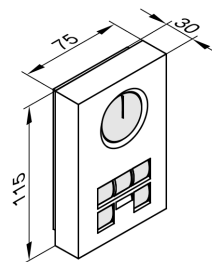

Specification

Power supply via KM BUS	
Power consumption	0.2 W
Protection class	III
Protection level	IP 30 to EN 60529; safeguard through appropriate design and installation
Permissible ambient temperature	
– during operation	0 to +40 °C
– during storage and transport	-20 to +65 °C
Set room temperature range	10 to 30 °C
	adjustable from 3 to 23 °C or 17 to 37 °C

The set room temperature for reduced mode is adjusted at the control unit.

Vitotrol 300

Part no. 7248 907

KM BUS subscriber

The Vitotrol 300 remote control regulates the required set room temperature for one heating circuit in standard and reduced mode, the heating program and the switching times for central heating, DHW heating and the DHW circulation pump.

The Vitotrol 300 provides a backlit display as well as backlit heating program keys, a party and economy key, automatic summer/winter time changeover, keys for holiday program, day and time.

WS function:

Installation at any point in the building.

RS function:

Installation in the main living room on an internal wall opposite radiators. Never install inside shelf units, niches, immediately by a door or heat source (e.g. direct sunlight, fireplace, TV set, etc.).

The integral room temperature sensor captures the actual room temperature and effects any necessary correction of the flow temperature as well as a rapid heat-up at the start of the heating operation (if suitably encoded).

Connection:

- 2-core lead, length max. 50 m (even if connecting several remote control units)
- Never route this lead immediately next to 230/400 V cables
- LV plug as standard delivery

Accessories for the Vitotronic 200 (cont.)

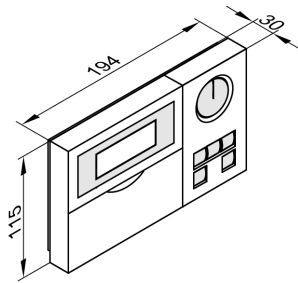

Power consumption	0.5 W
Protection class	III
Protection	IP 30 to EN 60529; safeguard through appropriate design and installation
Permissible ambient temperature	
– during operation	0 to +40 °C
– during storage and transport	-20 to +65 °C
Set room temperature range	
– for standard mode	10 to 30 °C adjustable to 3 to 23 °C or 17 to 37 °C
– for reduced mode	3 to 37 °C

Specification

Power supply via KM BUS

Room temperature sensor

Part no. 7408 012

Separate room temperature sensor as supplement to the Vitotrol 200 and 300; to be used if the Vitotrol 200 or 300 cannot be installed inside the main living room or in a suitable position where the unit can capture and adjust the temperature.

Installation in the main living room on an internal wall opposite radiators. Never install inside shelf units, recesses, immediately by a door or heat source (e.g. direct sunlight, fireplace, TV set, etc.).

Connect the room temperature sensor to the Vitotrol 200 or 300.

Connection:

- 2-core lead with a cross-section of 1.5 mm² (copper)
- Lead length from the remote control up to 30 m
- Never route this lead immediately next to 230/400 V cables

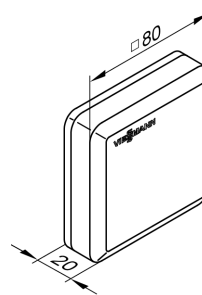

Specification

Protection class	III
Protection level	IP 30 to EN 60529; safeguard through appropriate design and installation
Permissible ambient temperature	
– during operation	0 to +40 °C
– during storage and transport	-20 to +65 °C

Radio clock receiver

Part no. 7450 563

For receiving the DCF 77 time signal (location: Mainflingen near Frankfurt/Main).

Radio controlled setting of time and date.

Install on an outside wall, facing the transmitter. The reception may be reduced by metallic elements in the building structure, e.g. steel reinforced concrete, neighbouring buildings and sources of electro-magnetic interference, e.g. HV and public transport lines.

Connection:

- 2-core lead, length up to 35 m with a cross-section of 1.5 mm² (copper)
- Never route this lead immediately next to 230/400 V cables.

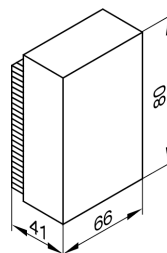

Accessories for the Vitotronic 200 (cont.)

Vitohome 300

Part no. Z005 395

Home centre for the wireless individual room temperature control system of central heating systems with radiators and/or underfloor heating.

- Increased individual room comfort
 - Saving heating and power costs
 - Easy commissioning and easy to retrofit
 - Complete operation for DHW and central heating
- For further information, see "Vitohome 300" datasheet.

Vitocom 100, type GSM

- Without SIM card
Part no. Z004594
- With contract SIM card for the operation of the Vitocom 100 via mobile phone
Part no. Z004615

Note

For further information regarding the conditions of contract, see the Viessmann pricelist.

Functions:

- Remote switching via GSM mobile phone networks
- Remote scanning via GSM mobile phone networks
- Remote monitoring via SMS to 1 or 2 mobile phones
- Remote monitoring of additional systems via digital input (230 V)

Configuration:

Mobile phones via SMS

Standard delivery:

- Vitocom 100 (subject to order with or without SIM card)
- Power supply cable with Euro plug (2.0 m long)
- GSM aerial (3.0 m long), magnetic foot and adhesive pad
- KM BUS cable (3.0 m long)

On-site requirements:

Good reception for GSM communication of the selected mobile phone operator.
Total length of all KM BUS subscriber cables up to 50 m.

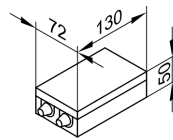

Specification

Rated voltage	230 V ~
Rated frequency	50 Hz
Rated current	15 mA
Power consumption	4 W
Protection class	II
Protection	IP 41 to EN 60529; safeguard through appropriate design and installation
Function	Type 1B to EN 60 730-1
Permissible ambient temperature – during operation	0 to +55 °C
– during storage and transport	Installation in living spaces or boiler rooms (standard ambient conditions)
On-site connection	-20 to +85 °C
Fault input DE 1	230 V~

Vitocom 200, type FA4 and GP1

- Type FA4 for analog telephone networks
Part no. Z005 399
- Type GP1 for GSM mobile phone networks, with SIM card (only available in (D))
Part no. Z005 405

Note

For further information regarding the conditions of contract, see the Viessmann pricelist.

For telecontrol, remote setup and monitoring of heating systems via analog and mobile telephone networks.

Standard delivery:

- Power supply cable (2 m long) with plug
- LON cable, 7 m long
- LON communication module for fitting into the control unit (for connecting the Vitocom 200 to the control unit, a LON communication module must be fitted in the control unit)
- Only type FA4: Analog modem (including connecting cable with plug for telephone socket (TAE6N), 2 m long)
- Only type GP1: GSM modem (including aerial and connecting cable, 3 m long)

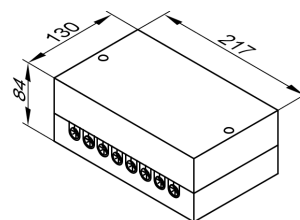

Specification

Rated voltage	230 V ~
Rated frequency	50 Hz
Rated current	22 mA
Power consumption	5 VA
Protection class	II
Protection	IP 20 to EN 60529; safeguard through appropriate design and installation
Function	Type 1B to EN 60 730-1
Permissible ambient temperature	

Accessories for the Vitotronic 200 (cont.)

- during operation 0 to +50 °C
Installation in living spaces
or boiler rooms (standard
ambient conditions)
- during storage and transport -20 to +85 °C
- On site connections zero volt contact, breaking
capacity 24 V ~, 7 mA
- Fault input DE 1 and DE 2 230 V ~/30 V-, 2 A
- Switching output (changeover)

Functions for telecontrol, remote setup and monitoring of heating systems

- Remote monitoring
 - Transferring information via SMS to a mobile phone/PDA
 - Transferring information via e-mail to a PC/PDA (requires e-mail client function)
 - Monitoring of additional devices

Functions for operation via the Vitodata 100 (via the web server integrated in the Vitocom 200):

- Telecontrol
 - Access to all heating circuits in the system
 - Operation of the heating programs and set values
 - Setting the holiday program, the switching times and the heating curve
- Remote setup
 - With the Vitosoft 200 software, type LNR (for configuring the Vitocom 200, type FA4 and GP1 in conjunction with a PC/laptop)
 - Configuring the Vitocom 200 parameters

Functions for the operation via the Vitodata 300 (via central web server):

- Telecontrol
 - Operation of the heating programs and set values
 - Setting the holiday program, the switching times and the heating curve
- Remote setup

- Configuring the Vitocom 200 parameters
- Remote setup of the Vitotronic control parameters via coding addresses

Communication

- Communication via Vitodata 100
 - PC with Web browser for operation and transferring information via e-mail
 - PDA with Web browser for operation and transferring information via SMS/e-mail
 - Mobile phone for transferring information via SMS
- Communication via Vitodata 300
 - PC with Web browser for operation and transferring information via e-mail
 - Mobile phone for transferring information via SMS
 - Fax for transferring information

Connections

Vitocom 200 in a compact casing for wall mounting with the following connections:

- 2 zero volt (or 24 V LV) digital inputs for monitoring additional equipment or third party systems
- 1 Relay output (230 V~) for device control
- RJ45 socket for the connection to the LON network of the Vitotronic control unit
- Supply voltage 230 V~
- Connection for linking up to the downstream interface in accordance with the Vitocom 200 equipment type

Interfaces

- **Vitocom 200, type FA4**
Telephone socket (TAE6N)
- **Vitocom 200, type GP1**
GSM/GPRS

For extended functions, an operation with the Vitocom 300 is also possible; see the Viessmann technical guide "Communication systems".

Extension kit for one heating circuit with mixer with integral mixer motor

Part no. 7178 995

KM BUS subscriber

Comprising:

- Mixer electronics with mixer motor for Viessmann mixer DN 20 to 50 and R 1/2" to 1 1/4"
- Flow temperature sensor (contact temperature sensor), lead length 2.2 m, fully wired, for specification, see below
- Connecting plug for the heating circuit pump
- Power supply cable (3.0 m long)
- BUS connecting cable (3.0 m long)

The mixer motor is mounted directly onto the Viessmann mixer DN 20 to 50 and R 1/2" to 1 1/4".

Mixer electronics with mixer motor

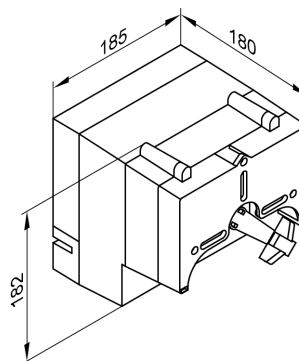

Specification

Rated voltage	230 V~
Rated frequency	50 Hz
Power consumption	6.5 W
Protection class	I
Protection	IP 32D to EN 60529; safeguard through appropriate design and installation

Permissible ambient temperature

Accessories for the Vitotronic 200 (cont.)

– during operation	0 to +40 °C
– during storage and transport	-20 to +65 °C
Rated breaking capacity of the relay output for the heating circuit pump [20]	4(2) A 230 V~
Torque	3 Nm
Runtime for 90 °<	2 min

Secured with a tie.

Specification

Cable length	2.2 m, fully wired
Protection	IP 32 to EN 60529; safeguard through appropriate design and installation

Flow temperature sensor (contact sensor)

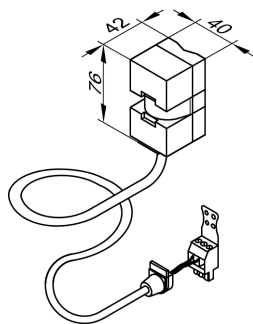

Permissible ambient temperature

– during operation	0 to +120 °C
– during storage and transport	-20 to +70 °C

Extension kit for one heating circuit with mixer for separate mixer motor

Part no. 7178 996

KM BUS subscriber

For the connection of a separate mixer motor.

Comprising:

- Mixer electronics for the connection of a separate mixer motor
- Flow temperature sensor (contact temperature sensor), lead length 5.8 m, fully wired
- Connecting plug for the heating circuit pump
- Mixer motor terminals
- Power supply cable (3.0 m long)
- BUS connecting cable (3.0 m long)

Mixer electronics

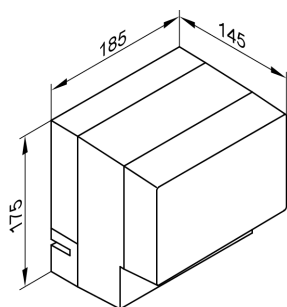

Specification, extension kit

Rated voltage	230 V~
Rated frequency	50 Hz
Power consumption	2.5 W
Protection class	I
Protection	IP 32D to EN 60529; safeguard through appropriate design and installation

Permissible ambient temperature

– during operation	0 to +40 °C
– during storage and transport	-20 to +65 °C

Rated breaking capacity of the relay outputs

– Heating circuit pump [20]	4(2) A 230 V~
– Mixer motor	0.2(0.1) A 230 V~
Required runtime of the mixer motor for 90 °<	approx. 120 s

Flow temperature sensor (contact sensor)

See page 28.

Immersion thermostat

Part no. 7151 728

May be used as a maximum temperature limiter for underfloor heating systems.

The temperature limiter is installed into the heating flow and switches the heating circuit pump OFF in case of excessive flow temperature.

Accessories for the Vitotronic 200 (cont.)

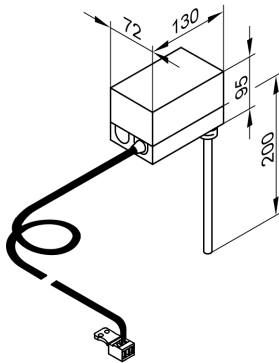

Specification

Cable length	4.2 m, fully wired
Setting range	30 to 80 °C
Switching differential	max. 11 K
Breaking capacity	6(1.5) A 250 V~
Setting scale	inside the casing
Stainless steel sensor well	R 1/2" x 200 mm
DIN reg. no.	DIN TR 77703
	or
	DIN TR 96803
	or
	DIN TR 110302

Contact thermostat

Part no. 7151 729

May be used as a maximum temperature limiter for underfloor heating systems (only in conjunction with metallic pipes). The temperature limiter is installed into the heating flow and switches the heating circuit pump OFF in case of excessive flow temperature.

Specification

Cable length	4.2 m, fully wired
Setting range	30 to 80 °C
Switching differential	max. 14 K
Breaking capacity	6(1.5) A 250V~
Setting scale	inside the casing
DIN reg. no.	DIN TR 77703
	or
	DIN TR 96803
	or
	DIN TR 110302

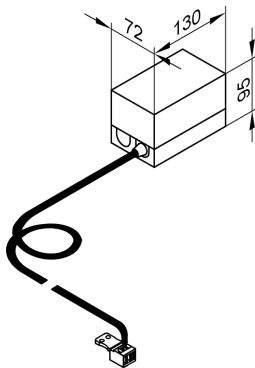

LON communication module

Electronic PCB for data exchange with the Vitotronic 200-H, Vitocom 200 and for connecting to a higher level building management system.

Part no. 7179 113

LON connecting cable for data exchange between control units

Part no. 7143 495

Cable length 7 m, fully wired.

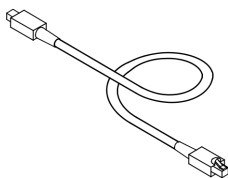

Accessories for the Vitotronic 200 (cont.)

Connecting cable extension

- Installation distance 7 to 14 m:
 - 2 connecting cables (7.0 m long)
Part no. 7143 495
 - 1 LON coupling RJ45
Part no. 7143 496
- Installation distance 14 to 900 m with plug-in connectors:
 - 2 LON plug-in connectors
Part no. 7199 251
 - 2-core cable, CAT5, screened or JY(St) Y 2 x 2 x 0.8
on-site
- Installation distance 14 to 900 m with junction boxes:
 - 2 connecting cables (7.0 m long)
Part no. 7143 495
 - 2-core cable, CAT5, screened or JY(St) Y 2 x 2 x 0.8
on-site
 - 2 LON sockets RJ45, CAT6
Part no. 7171 784

Terminator (2 pce.)

Part no. 7143 497

To terminate the LON BUS at the first and the last control unit.

KM BUS distributor

Part no. 7415 028

For the connection of 2 to 9 devices to the Vitotronic KM BUS.

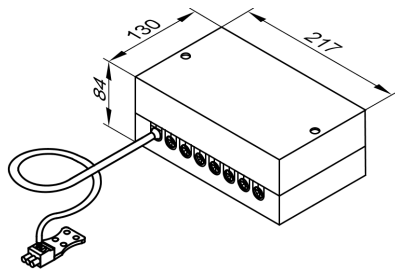

Specification

Lead length	3.0 m, fully wired
Protection	IP 32 to EN 60529; safeguard through appropriate design and installation
Permissible ambient temperature	
– during operation	0 to +40 °C
– during storage and transport	-20 to +65 °C

Immersion temperature sensor

Part no. 7179 488

To capture the low loss header temperature.

Specification

Lead length	3.75 m, fully wired	Protection	IP 32 to EN 60529 safeguard through appropriate design and installation
		Permissible ambient temperature	
		– during operation	0 to +90 °C
		– during storage and transport	-20 to +70 °C

Internal extension H1

Part no. 7179 057

Electronic PCB for installation into the control unit.

Using the extension enables the following functions to be achieved:

Function	Rated breaking capacity of the relay output
– Connection of an external safety solenoid valve (LPG) or – (A) connection of a flue gas damper	1(0.5) A 250 V~
and one of the following functions: – Connection of a heating circuit pump (stepped) for a directly connected heating circuit – Connection of a central fault message – Connection of a cylinder primary pump – Only with the Vitotronic 200, type HO1: – Connection of a DHW circulation pump	2(1) A 250 V~

5822 376 GB

Accessories for the Vitotronic 200 (cont.)

Specification

Rated voltage: 230 V~
Rated frequency: 50 Hz

Internal extension H2

Part no. 7179 144

Electronic PCB for installation into the control unit.

Using the extension enables the following functions to be achieved:

Function	Rated breaking capacity of the relay output
– External extractor interlock	6(3) A 250 V~
and one of the following functions:	2(1) A 250 V~
– Connection of a heating circuit pump (stepped) for a directly connected heating circuit	
– Connection of a central fault message	
– Connection of a cylinder primary pump	
– Only with the Vitotronic 200, type HO1: Connection of a DHW circulation pump	

Specification

Rated voltage 230 V~
Rated frequency 50 Hz

External extension H1

Part no. 7179 058

Function extension inside a casing for wall mounting.

Using the extension enables the following functions to be achieved:

Function	Rated breaking capacity of the relay output
– Connection of a central fault message	0.4(0.2) A 250 V~
– Connection of a heating circuit pump (stepped) for a directly connected heating circuit	every 2(1) A 250 V~ total max. 4 A~
– Connection of a cylinder primary pump	
– Only with the Vitotronic 200, type HO1: Connection of a DHW circulation pump	
– Minimum boiler water temperature demand	
– External blocking	
– Set boiler water temperature defaulted via a 0-10 V input	
– Only with the Vitotronic 200, type HO1: External operating mode changeover	

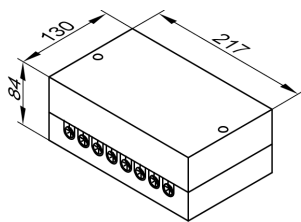

Specification

Rated voltage 230 V~
Rated frequency 50 Hz
Rated current 4 A
Power consumption 4 W
Protection class I
Protection IP 32

Permissible ambient temperature
– during operation 0 to +40 °C
Installation in living spaces or boiler rooms (standard ambient conditions)
– during storage and transport -20 to +65 °C

Accessories for the Vitotronic 200 (cont.)

External extension H2

Part no. 7179 265

Function extension inside a casing for wall mounting.

Using the extension enables the following functions to be achieved:

Function	Rated breaking capacity of the relay output
<ul style="list-style-type: none"> - Only with the Vitotronic 200, type HO1: Connection of a DHW circulation pump 	2(1) A 250 V~
<ul style="list-style-type: none"> - Minimum boiler water temperature demand - External blocking 	
<ul style="list-style-type: none"> - Only with the Vitotronic 200, type HO1: External operating mode changeover 	

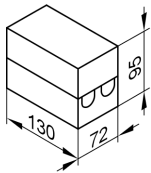

Specification

Rated voltage	230 V~
Rated frequency	50 Hz
Rated current	2 A
Power consumption	3 W
Protection class	I
Protection	IP 32
Permissible ambient temperature	
- during operation	0 to +40 °C Installation in living spaces or boiler rooms (standard ambient conditions)
- during storage and transport	-20 to +65 °C

Accessories for the Vitotronic 200 (cont.)

Selection of function extensions

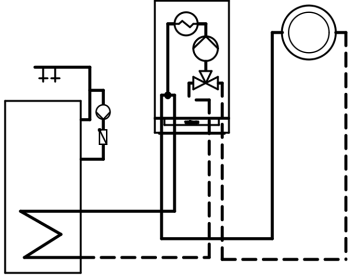
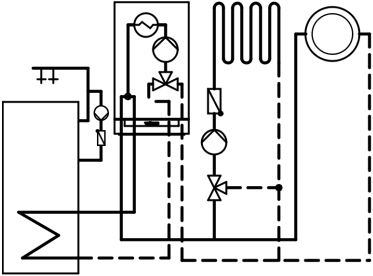
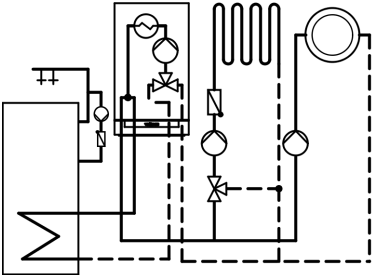
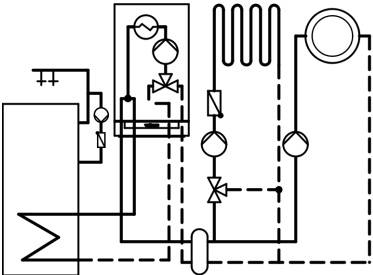
Heating system with a Vitodens 200-W		Function extension (part no.)		
		without safety function	with connection of a safety solenoid valve	with external extractor interlock
	- without DHW circulation pump	—	7179057	7179144
	- with DHW circulation pump	7179057 or 7179144 or 7179265	7179057	7179144
	- without DHW circulation pump	—	7179057	7179144
	- with DHW circulation pump	7179057 or 7179144 or 7179265	7179057	7179144
	- without DHW circulation pump	7179057 or 7179144	7179057	7179144
	- with a heating circuit pump (stepped) for a directly connected heating circuit	7179058	7179057 and 7179058	7179144 and 7179058
	- without DHW circulation pump	7179057 or 7179144	7179057	7179144
	- with a heating circuit pump (stepped) for a directly connected heating circuit	7179058	7179057 and 7179058	7179144 and 7179058

Accessories for the Vitodens 200-W

Pre-assembly accessories

See from page 11.

Accessories for the Vitodens 200-W (cont.)

Sub-mounting kit with mixer

Part no. 7199 505

Assembly for heat distribution via a heating circuit with mixer and one heating circuit without mixer as wall mounted version. For installation underneath the boiler.

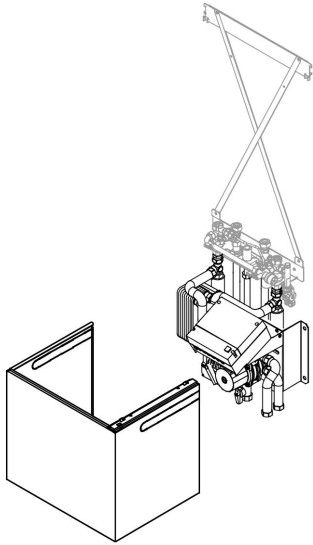

Components:

- Plate-type heat exchanger for system separation of the heating circuit with mixer
- Circulation pump for the heating circuit with mixer

- Three-way mixer with mixer motor
- Adjustable bypass
- Mixer PCB, capable of communicating with the Vitotronic 200 via the KM BUS
- Flow temperature sensor
- Cover in the same design as the wall mounted boiler
- Installation template for rapid and easy installation

The heating circuit without mixer is supplied by the integral boiler circulation pump.

The sub-mounting kit can only be used in conjunction with the Vitotronic 200 and the installation aid for finished walls.

Not in conjunction with the DHW cylinder Vitocell 100-W, below.

Sub-mounting kit accessories

Line regulating valve

For hydraulic balancing of the heating circuits.

High limit safety cut-out

Maximum temperature limiter for underfloor heating circuits. With connecting cable, 2.0 m long.

Scope of the sub-mounting kit

The following diagram indicates the relationship between the transferred output of the heating circuit with mixer and that of the heating circuit without mixer.

The diagram is based on the following system conditions:

- Pressure drop, heating circuit without mixer: 100 mbar
- ΔT heating circuit without mixer: 20 K
- ΔT heating circuit with mixer: 10 K

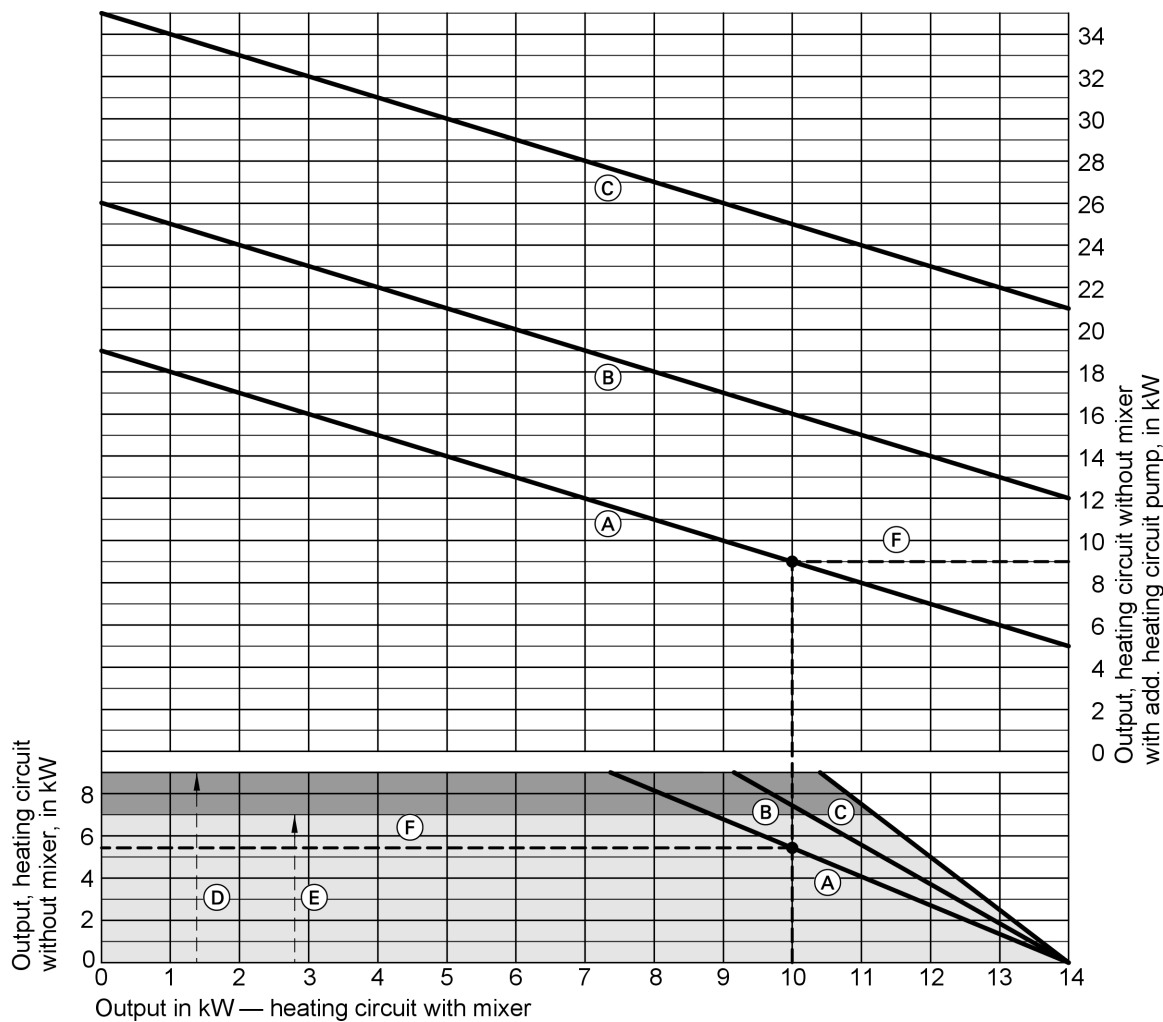

- Ⓐ Vitodens 200-W, 4.8 to 19 kW
- Ⓑ Vitodens 200-W, 6.5 to 26 kW
- Ⓒ Vitodens 200-W, 8.8 to 35 kW
- Ⓓ Output range of the heating circuit without mixer **without** line regulating valve

- Ⓔ Output range of the heating circuit without mixer **with** line regulating valve
- Ⓕ Example

Calculating the transferred output (example)

- Vitodens 200-W, 4.8 to 19 kW. Supplying the heating circuit without mixer through the internal circulation pump in the Vitodens 200-W.
 1. Output of the heating circuit with mixer at the horizontal axis (example: 10 kW).
 2. Extend the vertical line to the **lower** curve Ⓐ.
 3. Transfer the intersection of the horizontal to the l.h. vertical axis, and read off the transferred output of the heating circuit without mixer.
The example results in approx. 5.4 kW.
- Vitodens 200-W, 4.8 to 19 kW. Supplying the heating circuit without mixer through the additional external circulation pump in the heating circuit.

Note

This diagram applies only if the additional circulation pump has been correctly sized.

1. Output of the heating circuit with mixer at the horizontal axis (example: 10 kW).
2. Extend the vertical line up to the **upper** curve Ⓐ.
3. Transfer the intersection horizontally to the r.h. vertical axis, and read off the transferred output of the heating circuit without mixer.
The example results in approx. 9 kW.

Accessories for the Vitodens 200-W (cont.)

Specification, sub-mounting kit

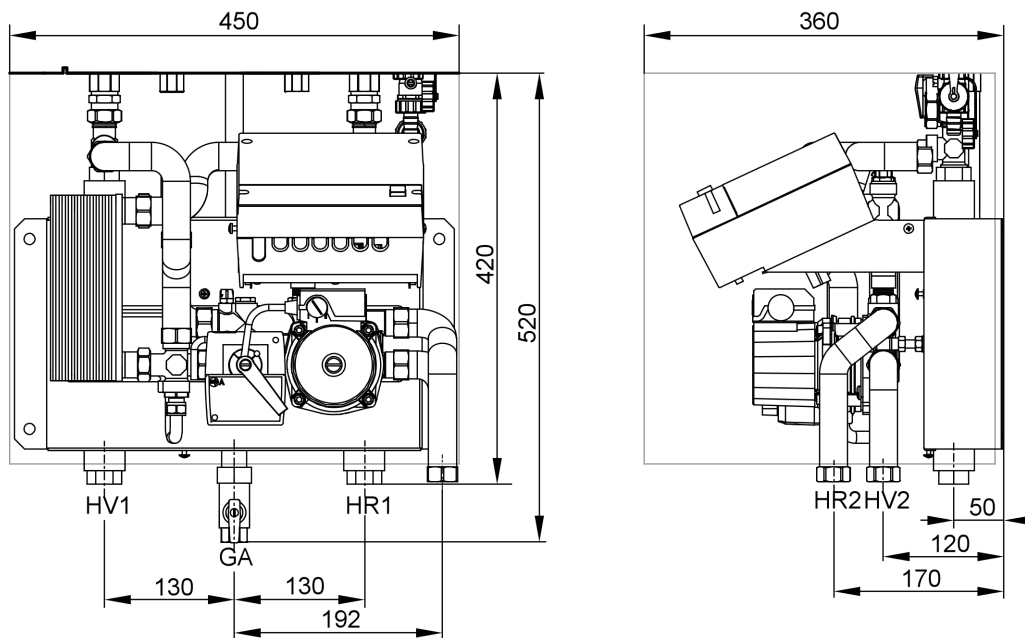

GA Gas connection Rp 1/2"

HR1 Heating return, heating circuit without mixer G 3/4"

HR2 Heating return, heating circuit with mixer G 3/4"

HV1 Heating flow, heating circuit without mixer G 3/4"

HV2 Heating flow, heating circuit with mixer G 3/4"

Max. transferable output of the heating circuit with mixer (ΔT 10 K)	kW	14
Max. flow rate of the heating circuit with mixer (ΔT 10 K)	l/h	1200
Permissible operating pressure	bar	3
Max. power consumption (total)	W	89
– Circulation pump	W	86
– Mixer motor	W	3
Weight (incl. packaging)	kg	17

Accessories for the Vitodens 200-W (cont.)

Residual head of the circulation pump for the heating circuit with mixer, integrated into the sub-mounting kit

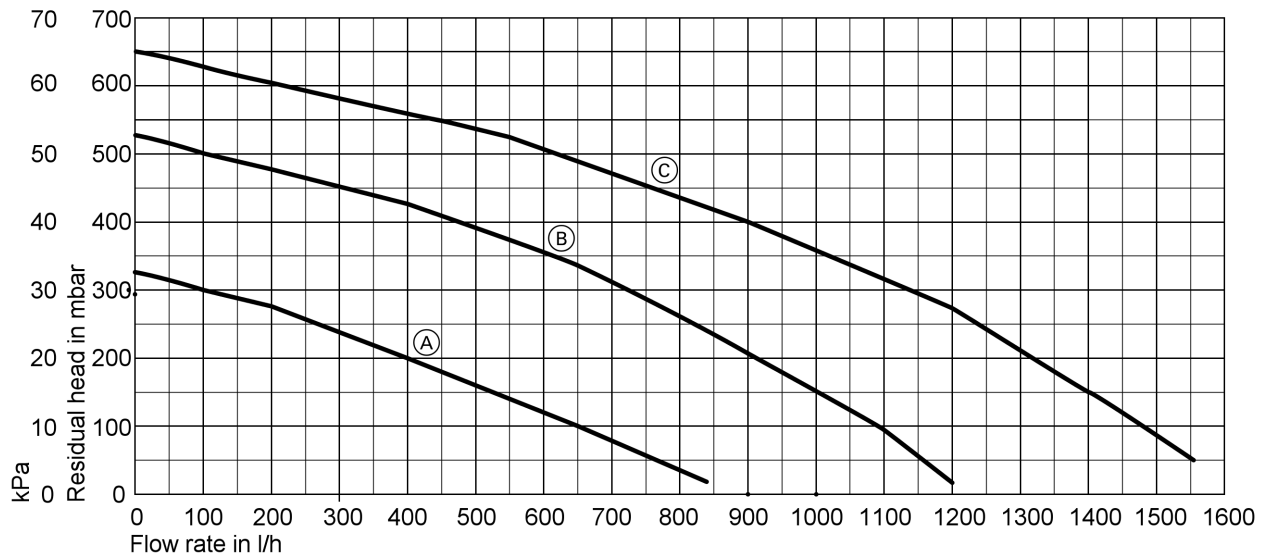

- Ⓐ Stage 1
- Ⓑ Stage 2
- Ⓒ Stage 3

Fitting cover

Part no. 7197 599

Not to be used in conjunction with wall mounted DHW cylinders and those installed below.

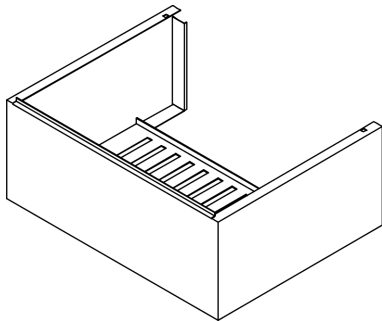

Neutralising system

Part no. 7252 666

With neutralising granulate

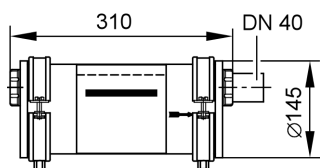

5822 376 GB

Accessories for the Vitodens 200-W (cont.)

Neutralising granulate

Part no. 9524 670
(2 × 1.3 kg)

Straight-through gas valve

R ½" for installation on finished walls

Part no. 7329 001
With integral thermally activated safety shut-off valve

Gas angle valve

R ½" for installation on unfinished walls

Part no. 7329 002
With integral thermally activated safety shut-off valve

Condensate lifting system

See Vitoset pricelist

Small softening system for heating water

For filling heating circuits.
See Vitoset pricelist.

Plate-type heat exchanger flushing system

Part no. 7179 753

Safety assembly to DIN 1988

Comprising:

- Shut-off valve
- Non-return valve and test nipples
- Pressure gauge connector
- Diaphragm safety valve

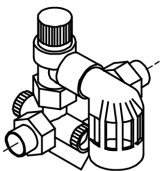

- 10 bar
 - DN 15, up to 200 litre cylinder capacity
Part no. 7219 722
 - DN 20, for 300 litre cylinder capacity
Part no. 7180 662
- **A** 6 bar
 - DN 15, up to 200 litre cylinder capacity
Part no. 7265 023
 - DN 20, for 300 litre cylinder capacity
Part no. 7179 666

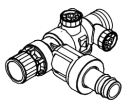

- For Vitocell 100-W, below
- 10 bar, DN 15, right angle version
Part no. 7180 097
 - **A** 6 bar, DN 15, right angle version
Part no. 7179 457

Accessories for the Vitodens 200-W (cont.)

Pressure reducer (DN 15)

Part no. 7180 148

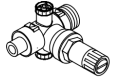

To match the safety assembly (right angle version)

Drain outlet kit

Part no. 7189 014

Drain outlet with siphon and bezel.

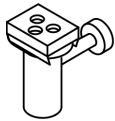

For the connection of the safety valve and condensate drain lines.

Accessories for the connection of the Vitodens 200-W with a DHW cylinder

Connection set for the wall mounted Vitocell 100-W DHW cylinder

Comprising:

- Cylinder temperature sensor
- Connection pipes on the heating water side
- Air vent valve on the heating water side

Installation on finished walls

DHW cylinder either on the l.h. or the r.h. side of the Vitodens.

Part no. 7178 345

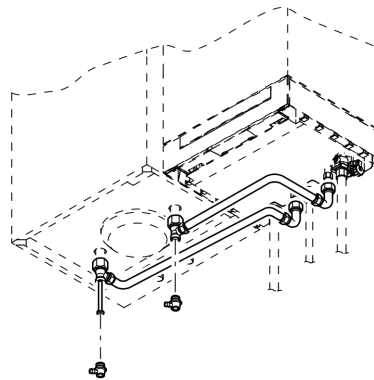

Connection set for the DHW cylinder Vitocell 100-W, below, with interconnecting pipes

Comprising:

- Cylinder temperature sensor
- Connection pipes on the heating water side
- Connection pipes on the DHW side

Accessories for the connection of the Vitodens 200-W with a DHW cylinder (cont.)

Installation on finished or unfinished walls
Part no. 7178 347

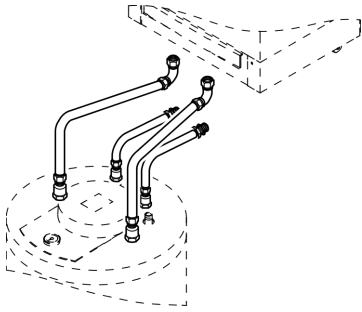

Casing to cover interconnecting pipes
With thermometer for the Vitocell

- For DHW cylinders with 120 l capacity
Part no. 7179 030
- For DHW cylinders with 150 l capacity
Part no. 7179 031

Connection set for the DHW cylinder Vitocell 100-W and 300-W, adjacent

Comprising:

- Cylinder temperature sensor
- Compression fittings (Rp 3/4")

DHW cylinder either on the l.h. or the r.h. side of the Vitodens

- Threaded version
Part no. 7178 349
- Solder version
Part no. 7178 348

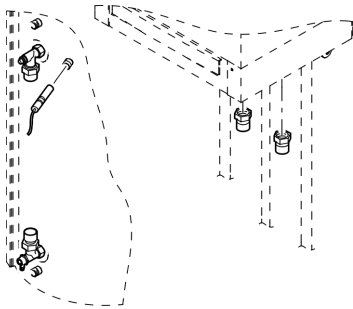

Delivered condition

Vitodens 200-W

Wall mounted gas fired condensing boiler with Inox-Radial heat exchanger, modulating Matrix cylinder burner for natural gas and LPG to DVGW Code of Practice G260 [Germany], Aqua-plate with multi-connect system and two-stage heating circuit pump. Fully plumbed and wired. Colour of the epoxy-coated casing: white.

With diaphragm expansion vessel.

For combi boilers:

Plate-type heat exchanger with convenience function for DHW heating.

Packed separately:

Vitotronic 100 for constant temperature operation or

Vitotronic 200 for weather-compensated operation.

Set up for operation with natural gas. A conversion within the gas group E/LL is not required. The conversion to LPG is made at the gas valve (a conversion kit is not required).

Delivered condition (cont.)

Accessories subject to installation method (order separately)

Vitodens installation directly onto a wall

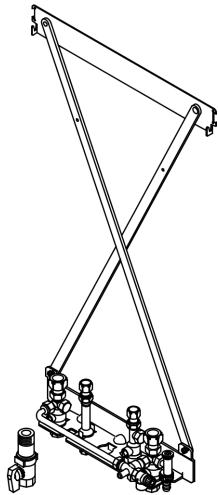

Installation aid, comprising:

- Fixing elements
- Valves/fittings
- Gas shut-off valve R 1/2" with thermally activated safety shut-off valve.

For installation either on finished or unfinished walls.

Vitodens installation in front of a wall

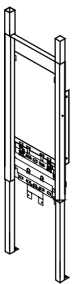

Self-supporting mounting frame (depth 110 mm).

Comprising:

- Valves/fittings
- Fixing parts
- Boiler fill & drain valve
- Gas angle valve G 3/4" with thermally activated safety shut-off valve.

For installation with threaded connections.

Design information

Installation for balanced flue operation

As device type C_{13x}, C_{33x}, C_{43x}, C_{53x} or C_{63x} to TRGI '86/96, the Vitodens can be installed for **balanced** flue operation **independent** of the size and ventilation of the installation room.

It may, for example, be installed in rooms with personnel traffic or in accommodation areas, in ancillary rooms without ventilation, in cupboards and recesses without maintaining minimum clearances to combustible components as well as in attic rooms (pitched attics and long pane rooms) where the balanced flue pipe can be directly routed through the roof.

The installation location must be safe from the risk of frost.

Installation for open flue operation

(Type B₂₃ and B₃₃)

Installation is only permissible if a direct ventilation aperture (which cannot be closed) with an unobstructed cross-section of at least 150 cm² is provided (to TRGI '86/96 [or local regulations]).

Installation in living spaces or other accommodation is **not** possible (exception: use with interconnected airways). Install the Vitodens near the chimney stack/duct.

Positioning

- Avoid air contamination by halogenated hydrocarbons (e.g. as in sprays, paints, solvents and cleaning agents)
 - Avoid very dusty conditions
 - Avoid high levels of humidity
 - Protect against frost and ensure good ventilation
- Otherwise, the system may suffer faults and damage.

Design information (cont.)

In rooms where **air contamination from halogenated hydrocarbons** is to be expected, operate the Vitodens only in balanced flue mode.

If these instructions are not observed, any consequential losses directly related to any of these causes are excluded from our warranty.

Flue systems

The plain flue pipe must be approved to DIN EN 14471 (**open flue operation**) [check local regulations].

The following Viessmann balanced flue systems for **balanced flue operation** are tested and CE-designated as a single technical unit together with the Vitodens :

- Vertical roof outlet
- External wall terminal

- Horizontal roof outlet
- Separate routing of ventilation air and flue gas
- External routing through a coaxial pipe

According to DIN EN 14471, the balanced flue components can be used for the connection of single boilers or multi-boiler systems to new or existing balanced flue chimneys.

For detailed descriptions of these flue gas systems, see the Vitodens technical guide.

Flue gas temperature protection

If a different flue gas system than those tested systems listed above is used on site, ensure connection in accordance with the guidelines for the approval of flue gas systems with low temperatures. For the Vitodens 200-W, these are flue pipes type B (max. permissible flue gas temperature 120 °C).

System design

- The boiler water temperature is limited to 82 °C.
To minimise distribution losses, we recommend that you size the heat distribution system to a max. flow temperature of 70 °C.
- Subject to local regulations, the installation of a condensing boiler may need to be notified.
- Only install suitable mixing devices in heating circuits, because the utilisation of condensing technology demands low return temperatures. Use only three-way mixers if mixers are required, e.g. for multi-circuit or underfloor heating systems.

Safety equipment

The boilers are equipped with a type-tested safety valve with a safety temperature of up to 100 °C in accordance with EN 12828 for hot water heating systems.

The safety valve is part of the installation aid or mounting frame.

Heating circuits

For heating systems with plastic pipes, we recommend the use of impermeable pipes to prevent the infusion of oxygen through the pipe walls. Provide system separation in heating systems with permeable plastic pipes (DIN 4726). We deliver a separate heat exchanger for this.

Install a sludge separator in underfloor heating systems; see the Viessmann Vitoset pricelist.

Connect underfloor heating systems and heating circuits with very large water content (> 15 litres/kW) to the boiler via a three-way mixer, even when using condensing boilers. See the technical guide "Control of underfloor heating systems" and the technical guides "Technical Guide – boilers" and "Standards for water quality".

Install a temperature limiter into the flow of the underfloor heating circuit to limit the maximum temperature. Observe DIN 18560-2.

Plastic pipework for radiators

We also recommend the installation of a temperature limiter to limit the maximum temperature of plastic pipes in heating circuits with radiators.

Design information (cont.)

Low water indicator

According to EN 12828, a special low water level indicator can be omitted for boilers up to 300 kW, as long as heating can be reliably prevented when the water level is too low.

Viessmann gas fired wall mounted boilers are equipped with a low water indicator (boil-dry protection). Tests have verified that the burner will be automatically switched OFF in the event of water shortage due to a leak in the heating system and simultaneous burner operation, before the boiler or flue gas systems reach unacceptably high temperatures.

Water quality/Frost protection

Unsuitable fill and top-up water increases the level of deposits and corrosion and may lead to boiler damage.

- Thoroughly flush the entire heating system prior to filling it with water.
- Only use fill water of potable quality.
- Soften fill water with a hardness above 3.0 mol/m³, e.g. with the small softening system for heating water (see the Viessmann Vitoset pricelist).
- An antifreeze additive suitable for heating systems can be mixed with the fill water. The antifreeze manufacturer must verify its suitability. For further details, see the VdTÜV datasheet 1466.
- For initial start-up or systems with a volume in excess of 20 litres/kW, observe VDI 2035 and the technical guide "Standards for water quality".

Drinking water quality

From a water hardness of 3.58 mol/m³ and higher, we recommend the use of DHW cylinders or a water treatment system in the cold water supply when heating DHW.

Condensate and neutralisation

See the "Vitodens technical guide".

Additional requirements for boilers with LPG when installed below ground level

According to TRF 1996 Vol. 2 – valid as of 1 September 1997 [Germany] – an external safety solenoid valve is no longer required when installing the Vitodens below ground level. However, the high safety standard derived from the use of an external safety solenoid valve has proved to be valuable. We therefore recommend the installation of an external safety solenoid valve plus the internal extension H1, when installing the Vitodens in rooms below ground level.

Technical guide

For further details regarding the design and sizing, see the "Vitodens technical guide".

Tested quality



VDE symbol approval applied for



CE designation according to current EC Directives

Meets the requirements for the "Blue Angel" certificate of environmental excellence to RAL UZ 61.

Printed on environmentally friendly,
chlorine-free bleached paper



Subject to technical modifications.

Viessmann Werke GmbH&Co KG
D-35107 Allendorf
Telephone: +49 6452 70-0
Fax: +49 6452 70-2780
www.viessmann.com

Viessmann Limited
Hortonwood 30, Telford
Shropshire, TF1 7YP, GB
Telephone: +44 1952 675000
Fax: +44 1952 675040
E-mail: info-uk@viessmann.com

5822 376 GB