



CRS-280

70/140 MHz IF Switch for 1:N Redundancy

CRS-280L

L-Band IF Switch for 1:N Redundancy

Installation and Operation Manual

Part Number MN-CRS-280/280L

Revision -

IMPORTANT NOTE: The information contained in this document supersedes all previously published information regarding this product. Product specifications are subject to change without prior notice.



Copyright © 2018 Comtech EF Data. All rights reserved. Printed in the USA.
Comtech EF Data, 2114 West 7th Street, Tempe, Arizona 85281 USA, 480.333.2200, FAX: 480.333.2161

Revision History

Rev	Date	Description
-	2-2018	Initial Release. Note: This manual supersedes MN/CRS280L.IOM.

TABLE OF CONTENTS

PREFACE	I
About this Manual	i
Related Documents	i
Conventions and References	ii
Patents and Trademarks	ii
Warnings, Cautions, and Notes	ii
Recommended Standard Designations	iii
Metric Conversion	iii
Electrical Safety	iii
Electrical Safety Notice	iii
Electrical Safety Compliance	iii
Fuses	iv
Environmental	iv
Installation	iv
Telecommunications Terminal Equipment Directive	v
Federal Communications Commission (FCC)	v
International Symbols	v
EMC (Electromagnetic Compatibility)	v
EN55022 - 1997 Compliance	v
EN55024 - 1998 Compliance	v
Product Support	vi
Comtech EF Data Headquarters	vi
Warranty Policy	vii
Limitations of Warranty	vii
Exclusive Remedies	viii
CHAPTER 1. INTRODUCTION	1-1
1.1 Overview	1-1
1.1.1 Compatibility	1-3
1.2 Physical Description	1-4
1.2.1 Front Panel	1-4
1.2.2 Rear Panel	1-5
1.2.3 Dimensional Envelope	1-6
1.3 Summary of Specifications	1-8
1.3.1 CRS-280L Typical Insertion Loss Graphs	1-10
CHAPTER 2. INSTALLATION	2-1
2.1 Unpacking and Inspection	2-1
2.2 Mounting	2-2
CHAPTER 3. CONNECTOR PINOUTS	3-1
3.1 Connector Overview	3-1
3.1.1 CRS-280 Connector Overview	3-2

3.1.2	CRS-280L Connector Overview.....	3-4
3.2	Front Panel Connectors	3-6
3.3	Rear Panel Control Connectors.....	3-6
3.3.1	CRS-280 Switch Control Interface Connector	3-6
3.3.1.1	J1 CRS Control Interface Connector, DB-25F	3-6
3.3.2	CRS-280L Switch Control Interface Connectors	3-7
3.3.2.1	J1 CRS Control Interface Connector, DB-25F	3-7
3.3.2.2	J2 SMS Control Interface Connector, DB-15M	3-7
3.3.2.3	Power / Ground Connections	3-8
3.3.2.3.1	Alternating Current (AC) Power Connectors	3-8
3.3.2.3.2	Direct Current (DC) Power Connectors (optional)	3-8
3.3.2.4	Ground Connector.....	3-9
CHAPTER 4.	CABLES AND CONNECTIONS.....	4-1
4.1	Overview	4-1
4.2	Control Cable Connections.....	4-2
4.2.1	SMS-7000 1:8 Modem Protection Switch Control Cable Connection	4-3
4.2.2	CRS-400 1:8 Redundancy Switch Control Cable Connection.....	4-3
4.2.3	CRS-300 1:N Redundancy Switch Control Cable Connection	4-3
4.2.4	CRS-500 M:N Redundancy System Control Cable Connection.....	4-4
4.3	Cable Connections.....	4-11
4.3.1	CRS-280 IF Cable Connections	4-11
4.3.2	CRS-280L L-Band IF Cable Connections.....	4-11
4.3.3	L-Band IF Cable Characteristics.....	4-11
4.3.4	L-Band Switch-to-Modem Cabling Requirements	4-11
4.3.5	L-Band Uplink/Downlink Cable Connections	4-12
CHAPTER 5.	REDUNDANCY SYSTEM CONFIGURATION / OPERATION.....	5-1
5.1	Overview	5-1
5.2	CRS-280L Input Power Cord Connections	5-1
5.3	1:N Redundancy System Power-up Sequence	5-2
5.3.1	CRS-280L operations with the CRS-500 M:N Redundancy System	5-2
APPENDIX A.	CABLE DRAWINGS	A-1
A.1	Introduction	A-1
A.2	Control Interface Cables.....	A-2
A.2.1	SMS-7000 Control Cable.....	A-3
A.2.2	CRS-400/CRS-300 Control Cable	A-4
A.2.3	CRS-500 Control Cable	A-5
A.3	IF Interface Cable, Type 'N' 50Ω.....	A-6
APPENDIX B.	CRS-280L POWER SUPPLY MODULE REPLACEMENT	B-1
B.1	Introduction	B-1
B.2	Power Supply Module Removal Procedure.....	B-3
B.3	Power Supply Module Installation Procedure.....	B-5

LIST OF FIGURES

Figure 1-1. CRS-280 70/140 MHz IF Switch for 1:N Redundancy	1-1
Figure 1-2. CRS-280L L-Band IF Switch for 1:N Redundancy	1-1
Figure 1-3. 1:10 Redundancy w/CRS-280L – System-level Block Diagram	1-3
Figure 1-4. CRS-280 Front Panel	1-4
Figure 1-5. CRS-280L Front Panel (1:10 Configuration shown)	1-4
Figure 1-6. CRS-280 Rear Panel	1-5
Figure 1-7. CRS-280L Rear Panel	1-5
Figure 1-8. CRS-280 (70/140 MHz) IF Switch Dimensional Envelope	1-6
Figure 1-9. CRS-280L (L-Band) IF Switch Dimensional Envelope	1-7
Figure 1-10. Graph 1 – Downlink Input to Rx Output.....	1-10
Figure 1-11. Graph 2 – Downlink Input to Backup Rx Output.....	1-11
Figure 1-12. Graph 3 – Backup Input to Selected Uplink Output.....	1-12
Figure 1-13. Graph 4 – Tx Input to Associated Uplink Output	1-13
Figure 3-1. CRS-280 Connectors	3-2
Figure 3-2. CRS-280L Connectors.....	3-4
Figure 4-1. SMS-7000 to CRS-280L Control Cable Connection	4-5
Figure 4-2. CRS-400 to CRS-280L Control Cable Connection.....	4-6
Figure 4-3. CRS-300 to CRS-280 Control Cable Connection.....	4-7
Figure 4-4. CRS-300 to CRS-280L Control Cable Connection.....	4-8
Figure 4-5. CRS-500 to CRS-280 Control Cable Connection.....	4-9
Figure 4-6. CRS-500 to CRS-280L Control Cable Connection.....	4-10
Figure A-1. CRS-280L → SMS-7000 Data Switch Unit (DSU) Control Cable (CEFD P/N CA/5343-1)...	A-3
Figure A-2. CRS-280L → CRS-400, CRS-300 Control Cable (CEFD P/N CA/WR0066).....	A-4
Figure A-3. CRS-280/280L → CRS-500 Data Switch Unit (DSU) Control Cable (CEFD P/N CA-0021666).....	A-5
Figure A-4. Type 'N' 50Ω IF Coax Cable (CEFD P/N CA/RF10453-x).....	A-6
Figure B-1. CRS-280L Rear Panel (shown with PL/10207-1 AC Modules)	B-2

LIST OF TABLES

Table 1-1. IF Switch Compatibility Table	1-2
Table 3-1. CRS-280 External Connectors (Front and Rear Panel).....	3-3
Table 3-2. CRS-280L External Connectors (Front and Rear Panel).....	3-5

Acronym List

Acronym	Description
AC	Alternating Current
CSU	Control Switch Unit
DC	Direct Current
ISU	IF Switch Unit
LED	Light Emitting Diode

PREFACE

About this Manual

This manual provides installation and operation information for the Comtech EF Data CRS-280L L-Band IF Switch, designed for use as a companion product in Comtech 1:N Redundancy Systems. This is a technical document intended for earth station engineers, technicians, and operators responsible for the operation and maintenance of the CRS-280/280L.

Comtech EF Data has reviewed this manual thoroughly in order to provide an easy-to-use guide to your equipment. All statements, technical information, and recommendations in this manual and in any guides or related documents are believed reliable, but the accuracy and completeness thereof are not guaranteed or warranted, and they are not intended to be, nor should they be understood to be, representations or warranties concerning the products described. Further, Comtech EF Data reserves the right to make changes in the specifications of the products described in this manual at any time without notice and without obligation to notify any person of such changes.

This is an informational document intended for the persons responsible for the operation and maintenance of the modem.

Related Documents

- Comtech EF Data CRS-300 1:10 Redundancy Switch Installation and Operation Manual
- Comtech EF Data CRS-500 M:N Redundancy System Installation and Operation Manual
- Comtech EF Data SMS-7000 1:8 Modem Protection Switch Installation and Operation Manual (legacy product, no longer in production)
- Comtech EF Data CRS-400 1:8 Redundancy Switch Installation and Operation Manual (legacy product, no longer in production)

Conventions and References

Patents and Trademarks

See all of Comtech EF Data's Patents and Patents Pending at <http://patents.comtechefdata.com>.

Comtech EF Data acknowledges that all trademarks are the property of the trademark owners.

Warnings, Cautions, and Notes



A **WARNING** gives information about a possible hazard that **MAY CAUSE DEATH** or **SERIOUS INJURY**.



A **CAUTION** gives information about a possible hazard that **MAY CAUSE INJURY** or **PROPERTY DAMAGE**.



A **NOTE** gives important information about a task or the equipment.



A **REFERENCE** directs the user to additional information about a task or the equipment.

Examples of Multi-Hazard Notices

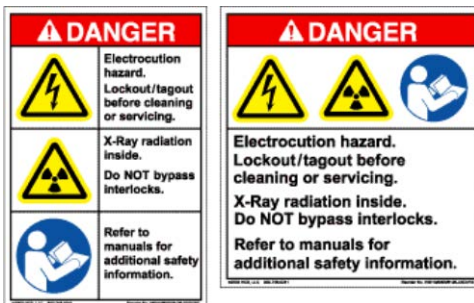

Recommended Standard Designations

Electronic Industries Association (EIA) designations supersede Recommended Standard (RS) designations. Reference to the old RS designations (e.g., RS-232) may appear where it might concern actual text displayed on the unit's rear panel, Serial Interface, or Web Server Interface pages. All other references in the manual use the EIA designations.

Metric Conversion

Metric conversion information is provided on the inside back cover of this manual. Comtech EF Data provides this information to assist the user in cross-referencing non-Metric to Metric conversions.

Electrical Safety

Electrical Safety Notice



Double pole / neutral fusing is used on the prime power supply input.

This equipment is designed to minimize exposure of personnel to hazards. For further information, contact the Comtech EF Data Customer Support Department. The persons responsible for the operation and maintenance of the equipment must:

- Know how to work around, with, and on high voltage equipment.
- Exercise every precaution to ensure personnel safety.
- Exercise extreme care when working near high voltages.
- Be familiar with the warnings presented in this manual.

Electrical Safety Compliance

The CRS-280L has been shown to comply with the following safety standard:

- EN60950: Safety of Information Technology Equipment, including electrical business machines

The equipment is rated for operation over the range 90-264 volts AC per each power supply. Each has a maximum power consumption of 25 Watts and draws a maximum of 0.75 Amps rms max @ 90 Volts AC, and 0.35 Amps rms max @ 230 Volts AC.

Optionally, the equipment is rated for operation over the range of 36-72 volts DC per each supply. Each has a maximum power consumption of 25 Watts and draws a maximum of 6.25 Amps.

Fuses



FOR CONTINUED OPERATOR SAFETY, ALWAYS REPLACE THE FUSES WITH THE CORRECT TYPE AND RATING.

The AC-powered CRS-280L is outfitted with two power supplies, each containing two fuses – one each for line and neutral connections. These are contained within the body of each IEC power inlet connector, behind a small plastic flap.

- For 230 volt AC operation, use T2.5A, 20mm fuses.
- For 115 volt AC operation, use T5.0A fuses, slow blow, P/N 5ASB-IEC.

The optionally DC-powered CRS-280L is outfitted with two power supplies. Each power supply contains one fuse installed into a fuse holder.

- For 48 volt DC operation, use T6.25A 3AG fuses.

Environmental

The CRS-280L must not be operated in an environment where the unit is exposed to extremes of temperature outside the ambient range 0 to 50°C, precipitation, condensation, or humid atmospheres above 95% RH, altitudes (non-pressurized) greater than 2000 meters, excessive dust or vibration, flammable gases, corrosive or explosive atmospheres.

Operation in vehicles or other transportable installations that are equipped to provide a stable environment is permitted. If such vehicles do not provide a stable environment, safety of the equipment to EN60950 may not be guaranteed.

Installation

The installation and connection to the line supply must be made in compliance to local or national wiring codes and regulations.

The CRS-280L is designed for connection to a power system that has separate ground, line and neutral conductors. The equipment is not designed for connection to a power system that has no direct connection to ground.

The CRS-280L is shipped with line inlet cables suitable for use in the country of operation. If it is necessary to replace these cables, ensure the replacement has an equivalent specification. Examples of acceptable ratings for the cable include HAR, BASEC and HOXXX-X. Examples of acceptable connector ratings include VDE, NF-USE, UL, CSA, OVE, CEBEC, NEMKO, DEMKO, BS1636A, BSI, SETI, IMQ, KEMA-KEUR and SEV.

Telecommunications Terminal Equipment Directive



In accordance with the Telecommunications Terminal Equipment Directive 91/263/EEC, this equipment should not be directly connected to the Public Telecommunications Network.

Federal Communications Commission (FCC)

This equipment has been tested and found to comply with the limits for a Class A digital device, pursuant to Part 15 of the FCC rules. These limits are designed to provide reasonable protection against harmful interference when the equipment is operated in a commercial environment.

This equipment generates, uses, and can radiate radio frequency energy. If not installed and used in accordance with the instruction manual, it may cause harmful interference to radio communications. Operation of this equipment in a residential area is likely to cause harmful interference; in which case, users are required to correct the interference at their own expense.

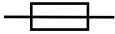
International Symbols

International Symbols			
Symbol	Definition	Symbol	Definition
~	Alternating Current		Protective Earth
	Fuse		Chassis Ground

EMC (Electromagnetic Compatibility)

This is a Class A product. In a domestic environment, it may cause radio interference that requires the user to take adequate protection measures.

EN55022 - 1997 Compliance

This equipment meets the radio disturbance characteristic specifications for information technology equipment as defined in EN55022-1997.

EN55024 - 1998 Compliance

This equipment meets the EMC/immunity characteristics for the limits and methods of measurement for information technology equipment per EN55024-1998.



To ensure that the CRS-280L continues to comply with these standards, observe the following instructions:

Connections to the transmit and receive IF ports ('N' type female connectors) should be made using a good quality coaxial cable; for example, RG213/U.

The 'D' type connector attached to the rear panel must have a back-shell that provides continuous metallic shielding. Cable with a continuous outer shield (either foil or braid, or both) must be used, and the shield must be bonded to the back-shell.

The equipment must be operated with both AC module panels assembled firmly to the rear of the chassis at all times. If it becomes necessary to remove either AC module, the user should ensure that the cover is correctly re-fitted before normal operation commences.

Product Support

For all product support, please call:

+1.240.243.1880

+1.866.472.3963 (toll free USA)

By email:

techsupport@comtechefdata.com

Comtech EF Data Headquarters

<http://www.comtechefdata.com>

Comtech EF Data Corp.

2114 West 7th Street

Tempe, Arizona USA 85281

+1.480.333.2200

Warranty Policy

Comtech EF Data products are warranted against defects in material and workmanship for a specific period from the date of shipment, and this period varies by product. In most cases, the warranty period is two years. During the warranty period, Comtech EF Data will, at its option, repair or replace products that prove to be defective. Repairs are warranted for the remainder of the original warranty or a 90 day extended warranty, whichever is longer. Contact Comtech EF Data for the warranty period specific to the product purchased.

For equipment under warranty, the owner is responsible for freight to Comtech EF Data and all related customs, taxes, tariffs, insurance, etc. Comtech EF Data is responsible for the freight charges only for return of the equipment from the factory to the owner. Comtech EF Data will return the equipment by the same method (i.e., Air, Express, Surface) as the equipment was sent to Comtech EF Data.

All equipment returned for warranty repair must have a valid RMA number issued prior to return and be marked clearly on the return packaging. Comtech EF Data strongly recommends all equipment be returned in its original packaging.

Comtech EF Data Corporation's obligations under this warranty are limited to repair or replacement of failed parts, and the return shipment to the buyer of the repaired or replaced parts.

Limitations of Warranty

The warranty does not apply to any part of a product that has been installed, altered, repaired, or misused in any way that, in the opinion of Comtech EF Data Corporation, would affect the reliability or detracts from the performance of any part of the product, or is damaged as the result of use in a way or with equipment that had not been previously approved by Comtech EF Data Corporation.

The warranty does not apply to any product or parts thereof where the serial number or the serial number of any of its parts has been altered, defaced, or removed.

The warranty does not cover damage or loss incurred in transportation of the product.

The warranty does not cover replacement or repair necessitated by loss or damage from any cause beyond the control of Comtech EF Data Corporation, such as lightning or other natural and weather related events or wartime environments.

The warranty does not cover any labor involved in the removal and or reinstallation of warranted equipment or parts on site, or any labor required to diagnose the necessity for repair or replacement.

The warranty excludes any responsibility by Comtech EF Data Corporation for incidental or consequential damages arising from the use of the equipment or products, or for any inability to use them either separate from or in combination with any other equipment or products.

A fixed charge established for each product will be imposed for all equipment returned for warranty repair where Comtech EF Data Corporation cannot identify the cause of the reported failure.

Exclusive Remedies

Comtech EF Data Corporation's warranty, as stated is in lieu of all other warranties, expressed, implied, or statutory, including those of merchantability and fitness for a particular purpose. The buyer shall pass on to any purchaser, lessee, or other user of Comtech EF Data Corporation's products, the aforementioned warranty, and shall indemnify and hold harmless Comtech EF Data Corporation from any claims or liability of such purchaser, lessee, or user based upon allegations that the buyer, its agents, or employees have made additional warranties or representations as to product preference or use.

The remedies provided herein are the buyer's sole and exclusive remedies. Comtech EF Data shall not be liable for any direct, indirect, special, incidental, or consequential damages, whether based on contract, tort, or any other legal theory.

Chapter 1. INTRODUCTION

1.1 Overview



Figure 1-1. CRS-280 70/140 MHz IF Switch for 1:N Redundancy



Figure 1-2. CRS-280L L-Band IF Switch for 1:N Redundancy

The CRS-280 (70/140 MHz) IF Switch (Figure 1-1) provides complete isolation of the IF signals. The Redundant Modem's IF signals are routed to the Traffic Modem's IF path when the Switch RMI is online. The Switch automatically senses the presence of the CRS-280. The Switch, upon switching, leaves the offline modem with its IF on, and the CRS-280's relays isolate any undesired signals.

The CRS-280 (70/140 MHz) IF Switch is necessary when one or more modems within the redundancy system connect to more than one up/down converter. This occurs when the modems connect to more than one transponder on the same antenna polarization, or when modem redundancy needs to span two or more polarizations or antennas.

The CRS-280L (L-Band) IF Switch (Figure 1-2) is designed to support redundancy systems featuring one Redundant (backup) Modem and up to 10 Traffic Modems (prime channels). Operation of the CRS-280L is controlled by the switching system to which it is connected.

The CRS-280L (L-Band) Switch is necessary when one or more modems within the redundancy system connect to the other polarization of the antenna or to multiple antennas.

The CRS-280/280L is designed for use with the following Comtech EF Data products:

Table 1-1. IF Switch Compatibility Table

Modem	Remarks	Max 1:N Redundancy
CDM-570L/570AL	Used with CRS-300 or CRS-500	1:10
CDM-600L	Used with CRS-300 or CRS-500 w/CRS-350 (ESC only)	1:10
CLM-9600L		
CDM-600/600L		
CDM-625/625A		
CDM-700 CDM-710 CDM-710G/710GL		
CDM-Qx/QxL		
SLM-5650/5650A		
SDM-300L3**	Used with SMS-7000**	1:8
SDM-2020D** (L-Band)	Used with CRS-400 (HSSI)**	1:10

**** Indicates a Comtech EF Data legacy product that is no longer in production**

The CRS-280 replaces the following Comtech EF Data active or legacy products:

- CRS-282 IF switch for 70/140 MHz applications

The CRS-280L replaces the following Comtech EF Data active or legacy products:

- IFU for SMS-7000 L-Band applications.
- CRS-282 IF switch for L-Band applications (CRS 300/CRS 500)

The CRS-280L features redundant power supplies with status Light Emitting Diodes (LEDs) on the front panel. It may be configured for 4 to 10 channel applications (SMS-7000 supports 8 channels max). Each channel has a transmit section with TX input / uplink output and a receive section with Rx output / downlink input.

Figure 1-3 shows the system level block diagram for a CRS-280L system.

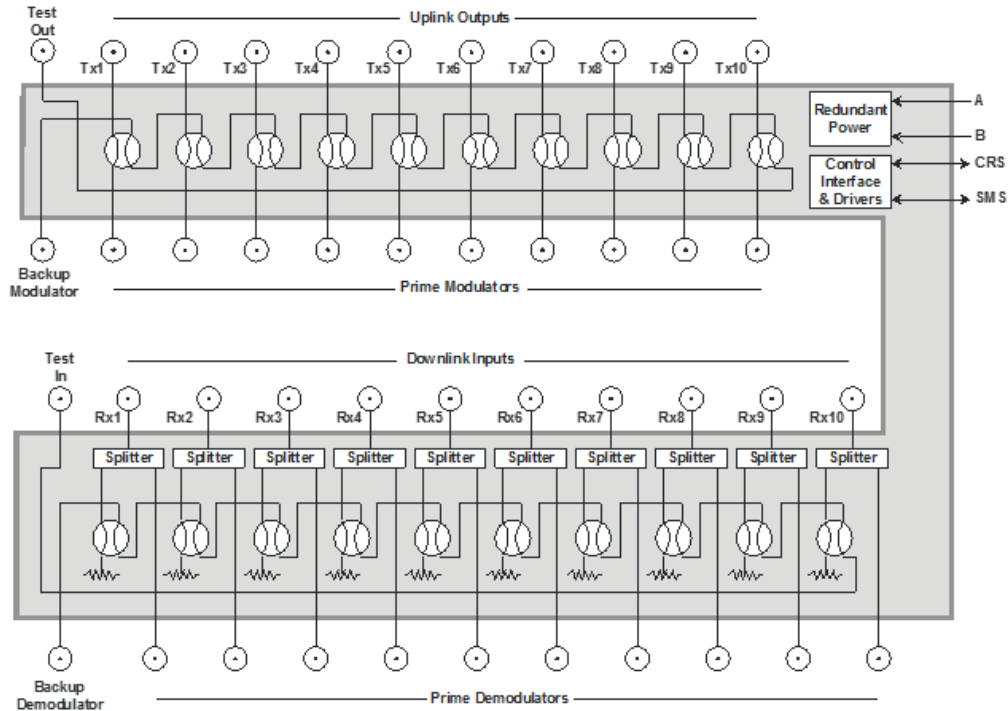

Figure 1-3. 1:10 Redundancy w/CRS-280L – System-level Block Diagram

1.1.1 Compatibility



The Comtech EF Data CRS-280/280L IF Switch is designed specifically as an accessory product for Comtech EF Data equipment. It is not designed to operate with any other manufacturer's equipment.

The CRS-280L is not designed to convey Direct Current (DC) power to external equipment such as LNBS or BUCs. Do not apply DC power to the L-Band input and output (Type 'N') ports of the switch. In addition, the CRS-280L is not designed to pass to 10 MHz reference or FSK signaling.

1.2 Physical Description

The CRS-280 is constructed as a 4RU-high, rack-mounting chassis that can be freestanding, if desired. Rack handles are not supplied.

The CRS-280L is constructed as a 4RU-high, rack-mounting chassis that can be freestanding, if desired. It is provided with rack handles at the front for easy removal from and placement into a rack.

1.2.1 Front Panel

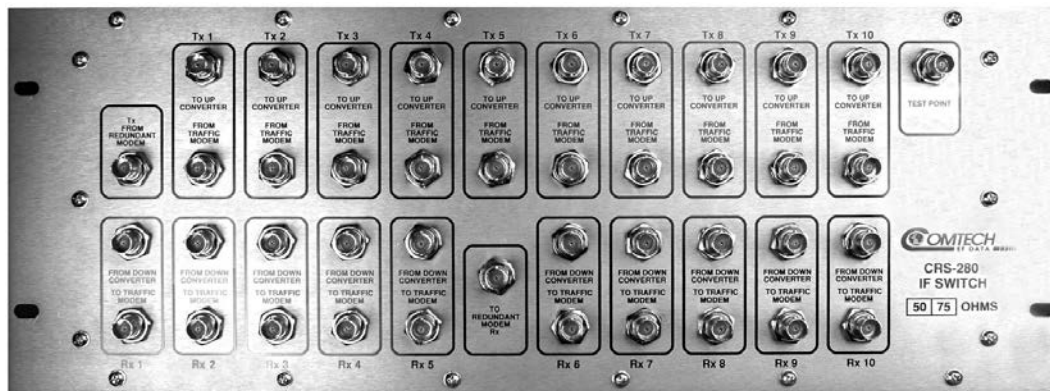

Figure 1-4. CRS-280 Front Panel

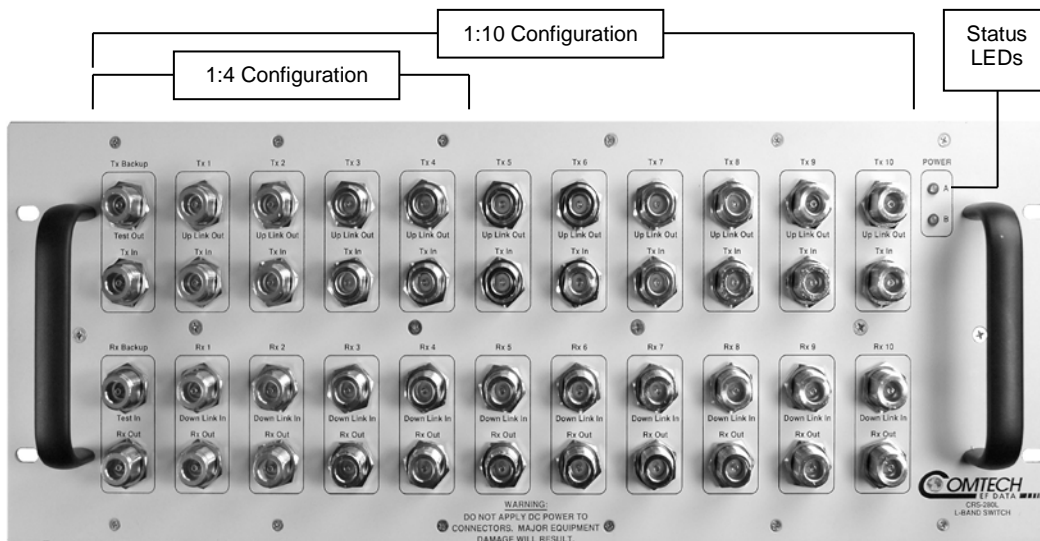

Figure 1-5. CRS-280L Front Panel (1:10 Configuration shown)

1.2.2 Rear Panel



Figure 1-6. CRS-280 Rear Panel

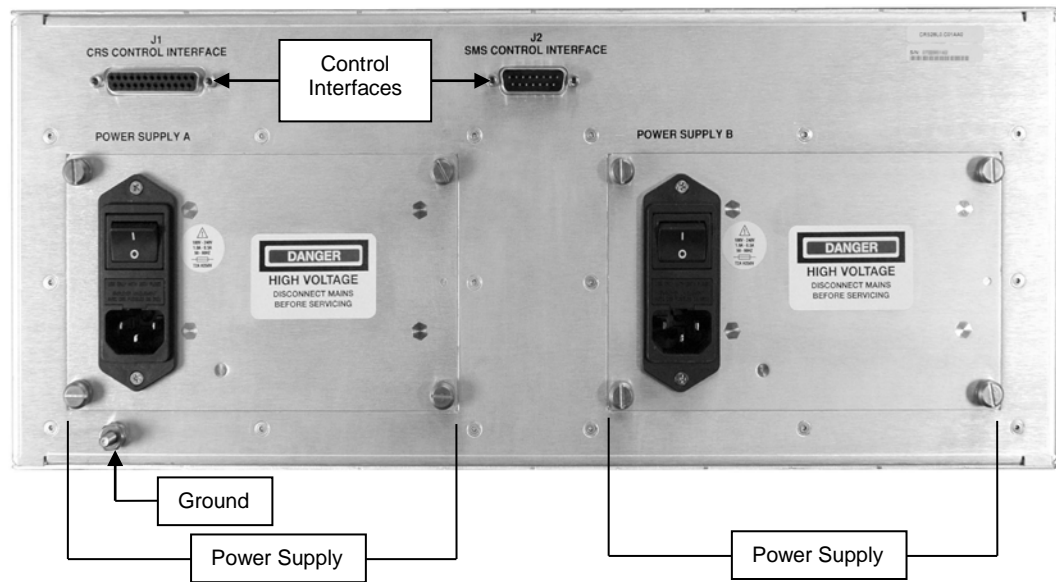

Figure 1-7. CRS-280L Rear Panel

1.2.3 Dimensional Envelope

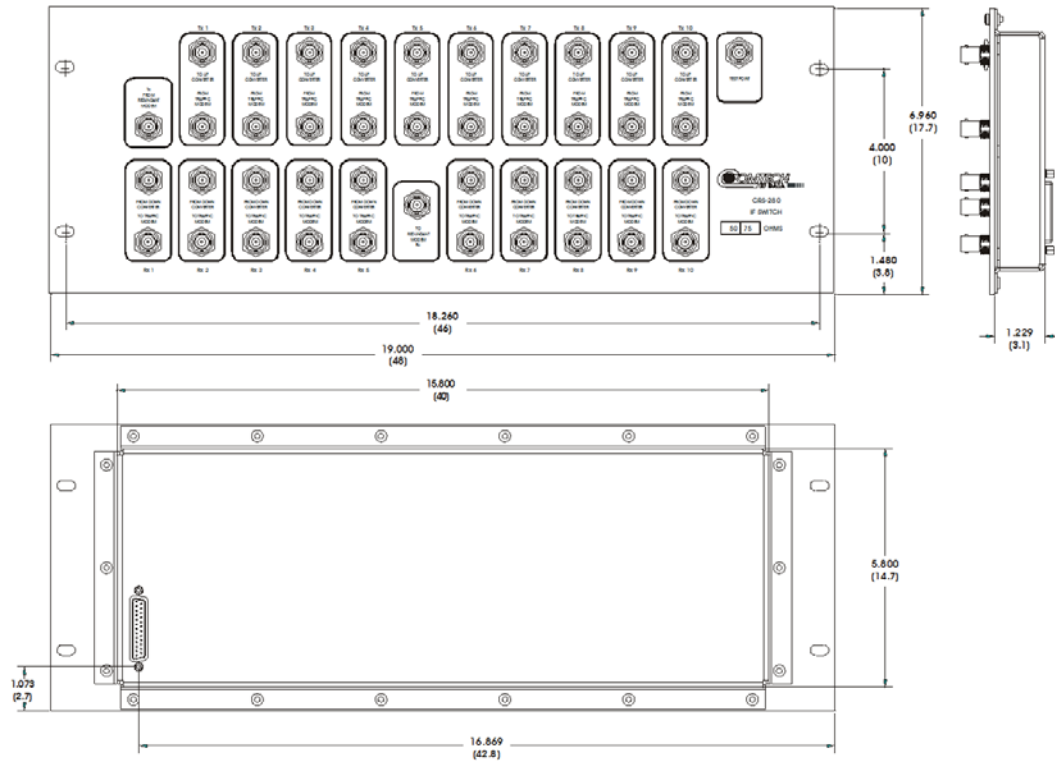

Figure 1-8. CRS-280 (70/140 MHz) IF Switch Dimensional Envelope

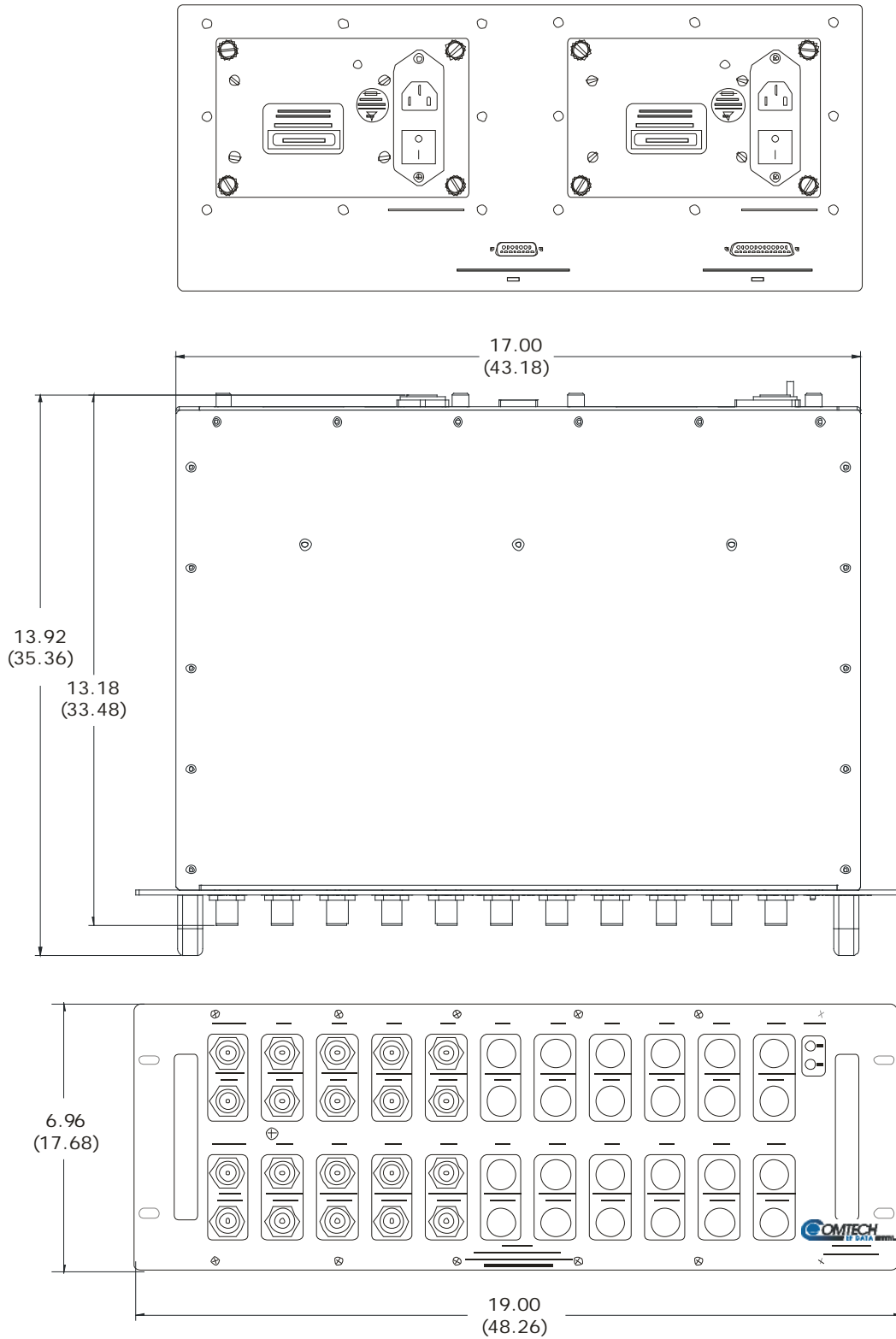

Figure 1-9. CRS-280L (L-Band) IF Switch Dimensional Envelope

1.3 Summary of Specifications

Equipment Type	CRS-280 (70/140 MHz)	CRS-280L (L-Band)
Comtech EF Data Modems Supported	<ul style="list-style-type: none"> • SDM-2020D (L-Band) (when used with CRS-400) (<i>legacy products</i>) • SDM-300L3 (when used with SMS-7000) (<i>legacy products</i>) • CDM-570L (when used with CRS-300 or CRS-500) • CDM-600L (when used with CRS-300) • CDM-9600L (when used with CRS-300) • CDM-625/625A (when used with CRS-300 or CRS-500) • SLM-5650A (when used with CRS-300 or CRS-500) 	<ul style="list-style-type: none"> • SDM-2020D (L-Band) (when used with CRS-400) (<i>legacy products</i>) • SDM-300L3 (when used with SMS-7000) (<i>legacy products</i>) • CDM-570L (when used with CRS-300 or CRS-500) • CDM-600L (when used with CRS-300) • CDM-9600L (when used with CRS-300) • CDM-625/625A (when used with CRS-300 or CRS-500) • SLM-5650A (when used with CRS-300 or CRS-500)
Tx/Rx Operating Frequency	50 to 180 MHz	950 to 2150 MHz
IF Impedance	50Ω and 75Ω	50Ω
TX Return Loss	18 dB return loss into 75Ω (50Ω optional)	< 12 dB return loss into 50Ω
TX to TX Channel Isolation	> 50 dB	> 70 dB
RX to RX Channel Isolation	> 50 dB	> 70 dB
TX to RX Channel Isolation	> 60 dB	> 90 dB
Tx IF Loss / Flatness		
TX (in) to associated Uplink (out)	< 1.5 dB over operating frequency	< 0.8 dB / 0.5 dB over operating frequency
BU (in) to any Uplink (out)	< 1.5 dB over operating frequency	< 2.5 dB / 1.0 dB over operating frequency
Rx IF Loss / Flatness		
DL (in) to associated RX (out)	< 5 dB over operating frequency	< 4.0 dB / 0.5 dB over operating frequency
Any DL (in) to BU RX (out)	< 5 dB over operating frequency	< 5.5 dB / 1.0 dB over operating frequency
Max. # of Downlinks	10	10
Tx/Rx IF Connectors	50/75Ω BNC female	50Ω Type 'N' female

Equipment Type	CRS-280 (70/140 MHz)	CRS-280L (L-Band)
Control Interface	25-pin sub-D female, compatible with CRS-300 controller	<ul style="list-style-type: none"> • 25-pin sub-D female, compatible with CRS-300 controller • 15-pin sub-D female, compatible with SMS-7000
Input Power	Received from an external power source, such as a modem chassis	Redundant 25 W, AC, Universal Input Switch Mode Power Supplies
Input voltage	N/A	90 - 264 VAC
Input frequency	N/A	47 - 440 Hz
Input current	N/A	0.75 A rms max. @ 90 VAC 0.35 A rms @ 230 VAC
Power Loss Failsafe	N/A	All uplinks/downlinks revert to associated L-Band inputs/outputs
Environmental		
Operating Temperature	32 to +122°F (0 to +50°C)	32 to +122°F (0 to +50°C)
Storage Temperature	-58 to +212°F (-50 to +100°C)	-58 to +212°F (-50 to +100°C)
Humidity	95% at +122°F (+50°C), Non-condensing	95% at +122°F (+50°C), Non-condensing
Dimensions	19" (48.26 cm) wide x 2.5" (6.35 cm) deep x 7" (17.78 cm) high	19" (48.26 cm) wide x 14" (35.56 cm) deep x 7" (17.78 cm) high
Weight	< 10 lbs (< 4.54 kg)	< 25 lbs (<11.35 kg)
EMC and Safety	<ul style="list-style-type: none"> • 'CE' as follows: <ul style="list-style-type: none"> ○ EN 55022-1997 Class A (Emissions) ○ EN-55024-1998 (EMC/Immunity) ○ EN 50082-1 (Immunity) ○ EN 60950 (Safety) • FCC Part 15 Class A 	<ul style="list-style-type: none"> • 'CE' as follows: <ul style="list-style-type: none"> ○ EN 55022-1997 Class A (Emissions) ○ EN-55024-1998 (EMC/Immunity) ○ EN 50082-1 (Immunity) ○ EN 60950 (Safety) • FCC Part 15 Class A

1.3.1 CRS-280L Typical Insertion Loss Graphs

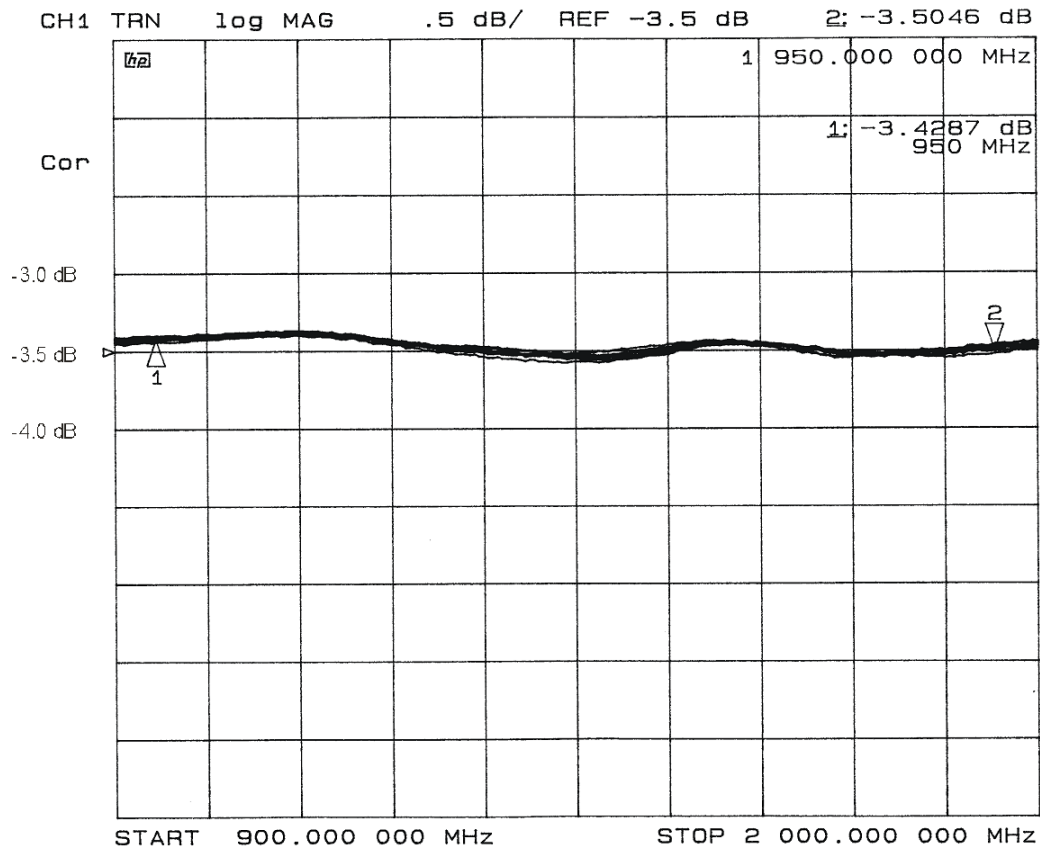

Figure 1-10. Graph 1 – Downlink Input to Rx Output

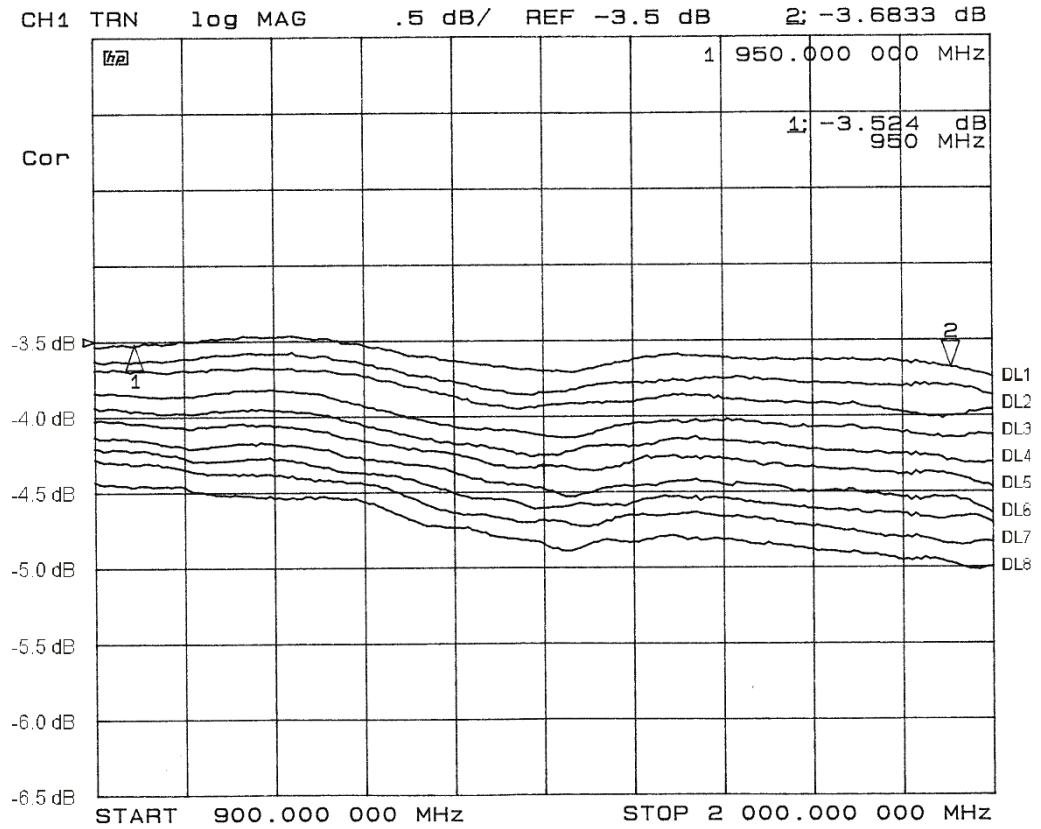

Figure 1-11. Graph 2 – Downlink Input to Backup Rx Output

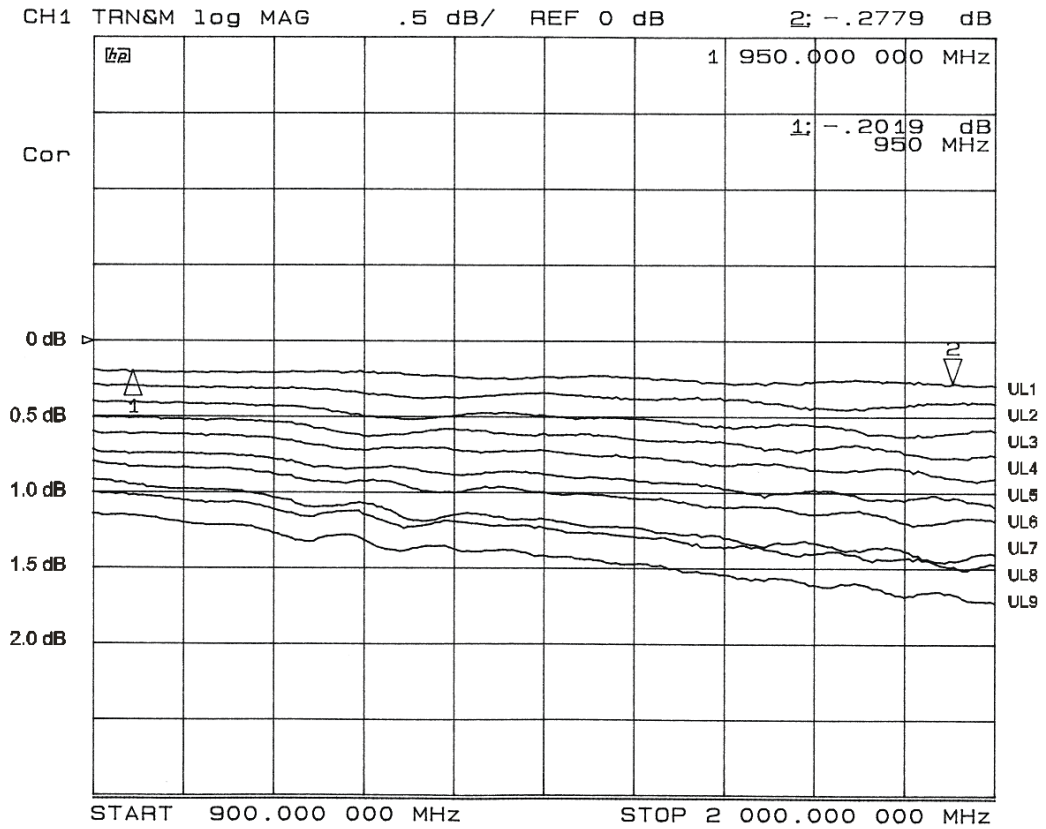

Figure 1-12. Graph 3 – Backup Input to Selected Uplink Output

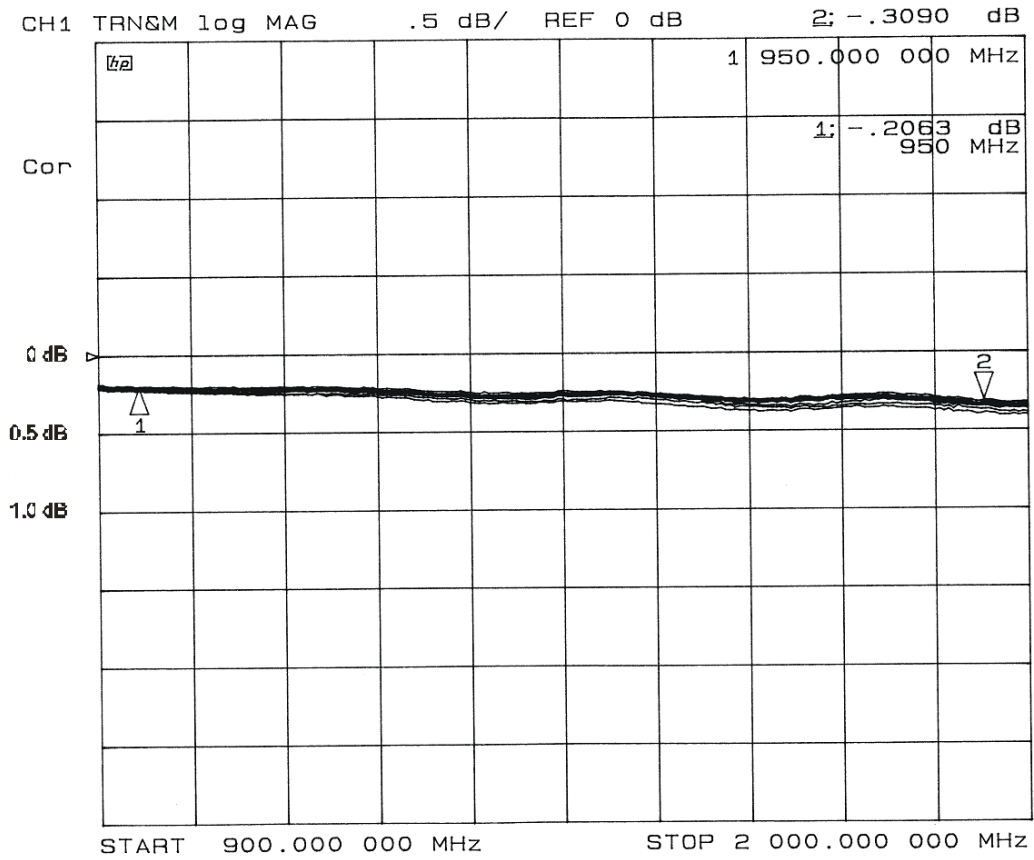

Figure 1-13. Graph 4 – Tx Input to Associated Uplink Output

Chapter 2. INSTALLATION

2.1 Unpacking and Inspection



Do not use any cutting tool that will extend more than 1” into the container and cause damage to the unit.



Be sure to keep all shipping materials for the carrier’s inspection.

The CRS-280/280L IF Switch for 1:N Redundancy is packaged and shipped in a pre-formed, reusable cardboard carton containing foam spacing for maximum shipping protection. The Installation and Operation manual can be found on Comtech EF Data’s website www.comtecheffdata.com under the *Download Manuals* tab, under *Modem Accessories Manuals*.

Unpack and inspect the CRS-280/280L as follows:

Step	Procedure
1	Inspect shipping containers for damage.
2	If shipping containers are damaged, keep them until the contents of the shipment have been carefully inspected and checked for normal operation.
3	Remove the packing list from the outside of the shipping carton.
4	Open the carton and remove the contents.
5	Check the contents against the packing list to verify completeness of the shipment.
6	If damage is evident, contact the carrier and Comtech EF Data immediately and submit a damage report.
7	If the unit needs to be returned to Comtech EF Data, use the original shipping container.

2.2 Mounting



Under no circumstance should the highest internal rack temperature be allowed to exceed 50°C (122°F)..



The CRS-280/280L CANNOT have rack slides mounted to the side of the chassis. Comtech EF Data recommends that an alternate method of support, such as rack shelves, is employed within the rack if front-mounting the unit is not feasible. If there is any doubt, please consult the Comtech EF Data Customer Support department.

The CRS-280 replaces the CRS-282 (used with the Comtech EF Data's CRS-300 1:10 Redundancy Switch, CRS-500 M:N Redundancy System, or CEFD legacy product CRS-400) and IFU (CEFD legacy product SMS-7000) for 70/140 MHz applications.

The CRS-280L replaces the CRS-282 (used with the Comtech EF Data's CRS-300 1:10 Redundancy Switch, CRS-500 M:N Redundancy System, or CEFD legacy product CRS-400) and IFU (CEFD legacy product SMS-7000) for L-Band applications.

The CRS-280L is constructed as a 4RU-high, rack-mounting chassis. Rack handles at the front of the unit facilitate removal from and placement into a rack. It is compatible with mounting at the top, back, or front of the rack (refer to the associated controller documentation for additional details).

To Install the CRS-280/280L:

Mount the switch with user-furnished hardware, using the unit's front panel mounting holes *only*. Since the switch itself is relatively passive, no additional clearance is needed between it and the nearest Modem.

Typically, the CRS-280/280L is mounted in a rack along with the modems with which it operates; therefore, it is important to ensure that there is adequate clearance for ventilation, particularly at the sides. In rack systems where there is high heat dissipation, forced air cooling must be provided by top or bottom mounted fans or blowers.

Chapter 3. CONNECTOR PINOUTS

3.1 Connector Overview



Chapter 4. CABLES AND CONNECTIONS

See **Chapter 4. CABLES AND CONNECTIONS** for complete details on IF cabling between the CRS-280/280L and its companion redundant switches, redundant and traffic modems, and uplink and downlink equipment.

3.1.1 CRS-280 Connector Overview



Front Panel View



Rear Panel View

Figure 3-1. CRS-280 Connectors

The front and rear panels of the CRS-280 IF Switch are shown in Figure 3-1.

The front panel connectors provide all necessary connections to connect all equipment internal and external to the 1:N redundancy setup. The rear panel connector of the CRS-280 provides the control connector between the CRS-280 and its companion redundancy switch (e.g., CRS-300, CRS-500, etc.).

Table 3-1 summarizes the connectors, grouped according to location (front, rear, or data interface) and service function.

Table 3-1. CRS-280 External Connectors (Front and Rear Panel)

Connector Group		Name	Connector Type	Function		
Front Panel	IF	(Transmit IF)	BNC female	70/140 Input	Tx Backup	Test Point
						Tx from Redundant Modem
		(Receive IF)	BNC female	70/140 Output	Rx Backup	Up Converter
						Tx from Traffic Modem
Rear Panel	Control Interface	J1 CRS Control Interface	25-pin Type 'D' female	Control interface for CRS-400**, CRS-300, CRS-500 Redundancy Switching products		
						Rx to Traffic Modem

** Indicates a Comtech EF Data legacy product that is no longer in production.



The European EMC Directive (EN55022, EN50082-1) requires using properly shielded cables for DATA I/O. These cables must be double-shielded from end-to-end, ensuring a continuous ground shield.

3.1.2 CRS-280L Connector Overview



Front Panel View

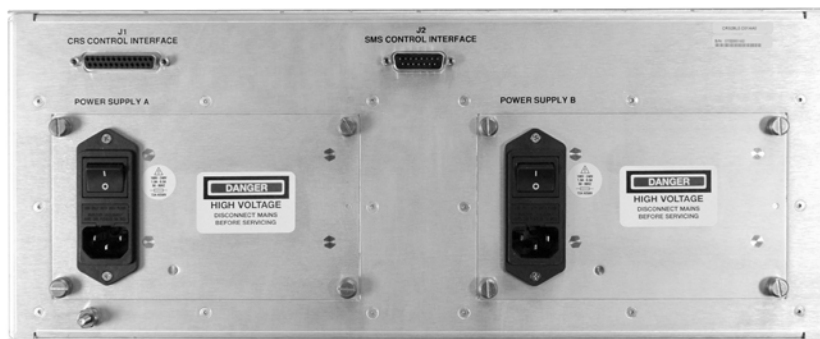

Rear Panel View (Standard AC Unit shown)

Figure 3-2. CRS-280L Connectors

The front and rear panels of the CRS-280L L-Band IF Switch are shown in Figure 3-2.

The front panel connectors provide all necessary connections to connect all equipment internal and external to the 1:N redundancy setup. The rear panel connectors of the CRS-280L provide the control connectors between the CRS-280L and its companion redundancy switch (e.g., CRS-300, CRS-500, etc.).

Table 3-2 summarizes the connectors, grouped according to location (front, rear, or data interface) and service function.

Table 3-2. CRS-280L External Connectors (Front and Rear Panel)

Connector Group		Name	Connector Type	Function		
Front Panel	IF	(Transmit IF)	22X Type 'N' 50Ω female	L-Band Input	Tx Backup	Test Out
						Tx In
					Tx Traffic 1-10	Up Link Out
		Tx In				
		(Receive IF)	22X Type 'N' 50Ω female	L-Band Output	Rx Backup	Test In
						Rx Out
Rx Traffic 1-10	Down Link In					
	Rx out					
Rear Panel	Control Interface	J1 CRS Control Interface	25-pin Type 'D' female	Control interface for CRS-400**, CRS-300, CRS-500 Redundancy Switching products		
		J2 SMS Control Interface	15-pin Type 'D' male	Control interface for SMS-7000** Redudancy Switching Product		
	Power / Ground	AC Input	2X IEC	p/o Primary and Backup AC Power Supply Modules (CEFD P/N PL/10207-1)		
		DC Input	2X 3-screw Terminal Block	p/o Optional Primary and Backup DC Power Supply Modules (CEFD P/N PL-0000355)		
		Ground	#10-32 stud	Common Chassis Ground		

** Indicates a Comtech EF Data legacy product that is no longer in production.



The European EMC Directive (EN55022, EN50082-1) requires using properly shielded cables for DATA I/O. These cables must be double-shielded from end-to-end, ensuring a continuous ground shield.

3.2 Front Panel Connectors

Unless otherwise noted, the connectors featured on the front panel of the CRS-280/280L are intended for connection to all IF equipment internal and external to the 1:N redundancy setup.

3.3 Rear Panel Control Connectors

Unless otherwise noted, the connectors featured on the rear panel of the CRS-280/280L are intended for connection to the companion redundancy switch control interface.

3.3.1 CRS-280 Switch Control Interface Connector

3.3.1.1 J1 CRS Control Interface Connector, DB-25F

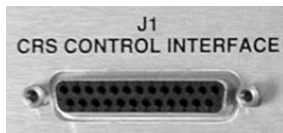

The 25-pin 'D' Type female (DB-25F) **J1 CRS Control Interface** connector is used to connect the CRS-280L to the **IF Switch Control** port, located on the CRS-230 Controller card installed in the CRS-400 1:8 Redundancy Switch or CRS-300 1:10 Redundancy Switch, or to the **P1 IF Switch Control** port located on the control interface side of the CRS-500 M:N Redundancy System's Data Switch Unit (DSU).



The Comtech EF Data CRS-400 1:8 Redundancy Switch is a legacy product that is no longer in production.

The J1 CRS Control Interface connector communicates with the logic interface of the companion redundancy switch to drive the currently selected terrestrial modem, and to decide whether the system is in bridged or backup mode. The CRS-280L performs the same bridging and backing up functions of the Tx and Rx IF signals to match what the companion redundant switch does to the terrestrial data signals.

3.3.2 CRS-280L Switch Control Interface Connectors

3.3.2.1 J1 CRS Control Interface Connector, DB-25F



The 25-pin 'D' Type female (DB-25F) **J1 CRS Control Interface** connector is used to connect the CRS-280L to the **IF Switch Control** port, located on the CRS-230 Controller card installed in the CRS-400 1:8 Redundancy Switch or CRS-300 1:10 Redundancy Switch, or to the **P1 IF Switch Control** port located on the control interface side of the CRS-500 M:N Redundancy System's Data Switch Unit (DSU).



The Comtech EF Data CRS-400 1:8 Redundancy Switch is a legacy product that is no longer in production.

The **J1 CRS Control Interface** connector communicates with the logic interface of the companion redundancy switch to drive the currently selected terrestrial modem, and to decide whether the system is in bridged or backup mode. The CRS-280L performs the same bridging and backing up functions of the Tx and Rx IF signals to match what the companion redundant switch does to the terrestrial data signals.

3.3.2.2 J2 SMS Control Interface Connector, DB-15M



The 15-pin 'D' Type male (DB-15M) **J2 SMS Control Interface** connector is used to connect the CRS-280L to the **J12 IF Control Interface** port of SMS-7000 1:8 Modem Protection Switch's Data Switch Unit (DSU).



The Comtech EF Data SMS-7000 1:8 Modem Protection Switch is a legacy product that is no longer in production.

3.3.2.3 Power / Ground Connections



For continued operator safety, always replace fuses with the correct type and rating.

3.3.2.3.1 Alternating Current (AC) Power Connectors



Two AC power supplies – one primary, one backup – are provided. For each, a standard, detachable, non-locking 3-prong power cord (IEC plug) supplies the Alternating Current (AC) power to the CRS-280L. Observe the following:

Standard AC Power Specifications	
Input Power	25W typical
Input Voltage	100 - 240 volts AC, +6%/-10% - autosensing (total absolute max. range is 90-264 volts AC)
Connector Type	IEC
Fuse Protection	1.0A Slow-blow (115 volt AC operation) 2.0A Slow-blow (230 volt AC operation) Line and neutral fusing 20 mm type fuses

3.3.2.3.2 Direct Current (DC) Power Connectors (optional)

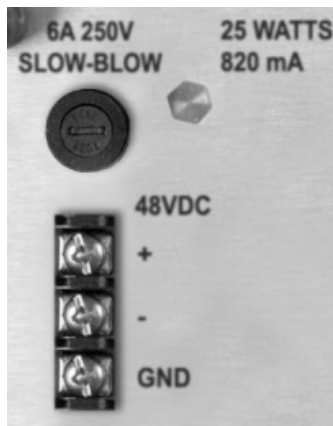

Two DC power supplies – one primary, one backup – are optionally available. For each, a standard, 3-screw terminal block with fuse holder supplies the Direct Current (DC) power to the CRS-280L. Observe the following:

Optional DC Power Specifications	
Input Power	25W maximum
Input Voltage	36 to 72 VDC; 6.25 amps
Connector Type	Terminal Block
Fuse Protection	6.25A Slow-blow

3.3.2.4 Ground Connector



The AC power connector provides the safety ground.



A #10-32 stud, located to the lower left hand side of the CRS-280L rear panel, is provided for connecting a common chassis ground among equipment.

BLANK PAGE

Chapter 4. CABLES AND CONNECTIONS

4.1 Overview



Chapter 2. INSTALLATION Appendix A. CABLE DRAWINGS

When assembling a Comtech EF Data 1:N Redundancy System, in addition to purchasing the desired modem group (one Redundant modem, up to 10 Traffic modems) and the appropriate companion switch (i.e., CRS-300, CRS-500 etc.), the user is also required to purchase all cables and components required for interconnection of the redundant configuration to various interfaces (i.e., control, IF, and data).

Once the CRS-280/280L switch, its companion redundancy switch, and all modems have been mounted as outlined in **Chapter 2. INSTALLATION**, the user must properly attach all required cabling, then configure the system for correct operation.

For the purpose of clarity, this chapter deals only with the connections needed for the CRS-280/280L's application *within* a configured 1:N Redundancy System. Refer to the applicable companion switch *Installation and Operation Manual* for pertinent data interface cabling and other cable connection information.

The sections that follow in this chapter provide specific interface examples that identify the individual redundancy cable(s) required to interconnect the two interfaces. For line drawings of the cables specified in this chapter, see **Appendix A. CABLE DRAWINGS**.



Leave the switch and all modems powered off until all connections are ready.

4.2 Control Cable Connections

Each CRS-280/280L is supplied with a control cable for connection to the associated 1:N Redundancy Switch control unit. The control cable must be specified at time of order:

1: N Redundancy Switch	CEFD Part No.	Description
SMS-7000**	CA/5343-1	Control Cable, DB-15F → DB-15M, 8'
CRS-400**	CA/WR0066	Control Cable, DB-25M → DB-25F, 6'
CRS-300		
CRS-500	CA-0021666	Control Cable, DB-9F → DB-25M, 8'

** Indicates a Comtech EF Data legacy product that is no longer in production.



1. **When connecting the Control cable between the CRS-280L and the redundancy switch, ensure that screw locks on the 'D' type connectors are securely fastened. This will prevent the accidental unmating of the cable, particularly when a standby unit is being removed or replaced.**
2. **Only one control interface must be used. Do not make connections to both control interfaces on the CRS-280L. The CRS-280L automatically detects the control interface in use and cannot function with both control cables connected.**

Connect the supplied cable between the Redundancy Switch (controller) and the CRS-280/280L (refer to the pertinent Redundancy Switch *Installation and Operation Manual* for additional information):

For CRS-280/280L →	Refer to:
SMS-7000 1:8 Modem Protection Switch**	Sect. 4.2.1
CRS-400 1:8 HSSI Redundancy Switch**	Sect. 4.2.2
CRS-300 1:N Redundancy Switch	Sect. 4.2.3
CRS-500 M:N Redunancy System	Sect. 4.2.4

4.2.1 SMS-7000 1:8 Modem Protection Switch Control Cable Connection



The Comtech EF Data SMS-7000 1:8 Modem Protection Switch is a legacy product that is no longer in production.

As shown in Figure 4-1:

Step	Instructions
1	Connect the DB-15F connector on the CA/5343-1 Control Cable to the DB-15M J2 SMS Control Interface port on the rear panel of the CRS-280L.
2	Connect the DB-15M connector on the CA/5343-1 Control Cable to the DB-15F J12 IF Control Interface port on the Control/Modem side of the SMS-7000 Data Switch Unit (DSU). Note: The CRS-280L serves to replace, in its entirety, the SMS-7000 IF Switch Unit (IFU).
3	Secure the cable by tightening the screw locks on both ends of the control cable.

4.2.2 CRS-400 1:8 Redundancy Switch Control Cable Connection



The Comtech EF Data CRS-400 1:8 Redundancy Switch is a legacy product that is no longer in production.

As shown in Figure 4-2:

Step	Instructions
1	Connect the DB-25M connector of the CA/WR0066 control cable to the DB-25F J1 CRS Control Interface port on the rear panel of the CRS-280L.
2	Connect the other end of the control cable to the DB-25M IF Switch Control port on the CRS-230 Controller card, installed in the rear panel of the CRS-400 1:8 Redundancy Switch.
3	Secure the cable by tightening the screw locks on both ends of the control cable.

4.2.3 CRS-300 1:N Redundancy Switch Control Cable Connection

As shown in Figure 4-3 and Figure 4-4:

Step	Instructions
1	Connect the DB-25M connector of the CA/WR0066 control cable to the DB-25F J1 CRS Control Interface port on the rear panel of the CRS-280/280L.
2	Connect the other end of the control cable to the DB-25M IF Switch Control port on the CRS-230 Controller card, installed in the rear panel of the CRS-300 1:N Redundancy Switch.
3	Secure the cable by tightening the screw locks on both ends of the control cable.

4.2.4 CRS-500 M:N Redundancy System Control Cable Connection

As shown in Figure 4-5 and Figure 4-6:

Step	Instructions
1	Connect the DB-25M connector of the CA-0021666 Control Cable to the DB-25F J1 CRS Control Interface port on the rear panel of the CRS-280/280L.
2	Connect the final DB-9F connector on the CA-0021666 Control Cable to the DB-9M P1 IF Switch Control port on the control interface side of the CRS-500 M:N Redundancy System's Data Switch Unit (DSU). Note: The CRS-500 DSU is, in turn, connected to the CRS-500 Control Switch Unit (CSU) via the CA-0000234 Control Cable – see the CRS-500 M:N Redundancy System Installation and Operation Manual for complete details.
3	Secure the cable by tightening the screw locks on both ends of the control cable.

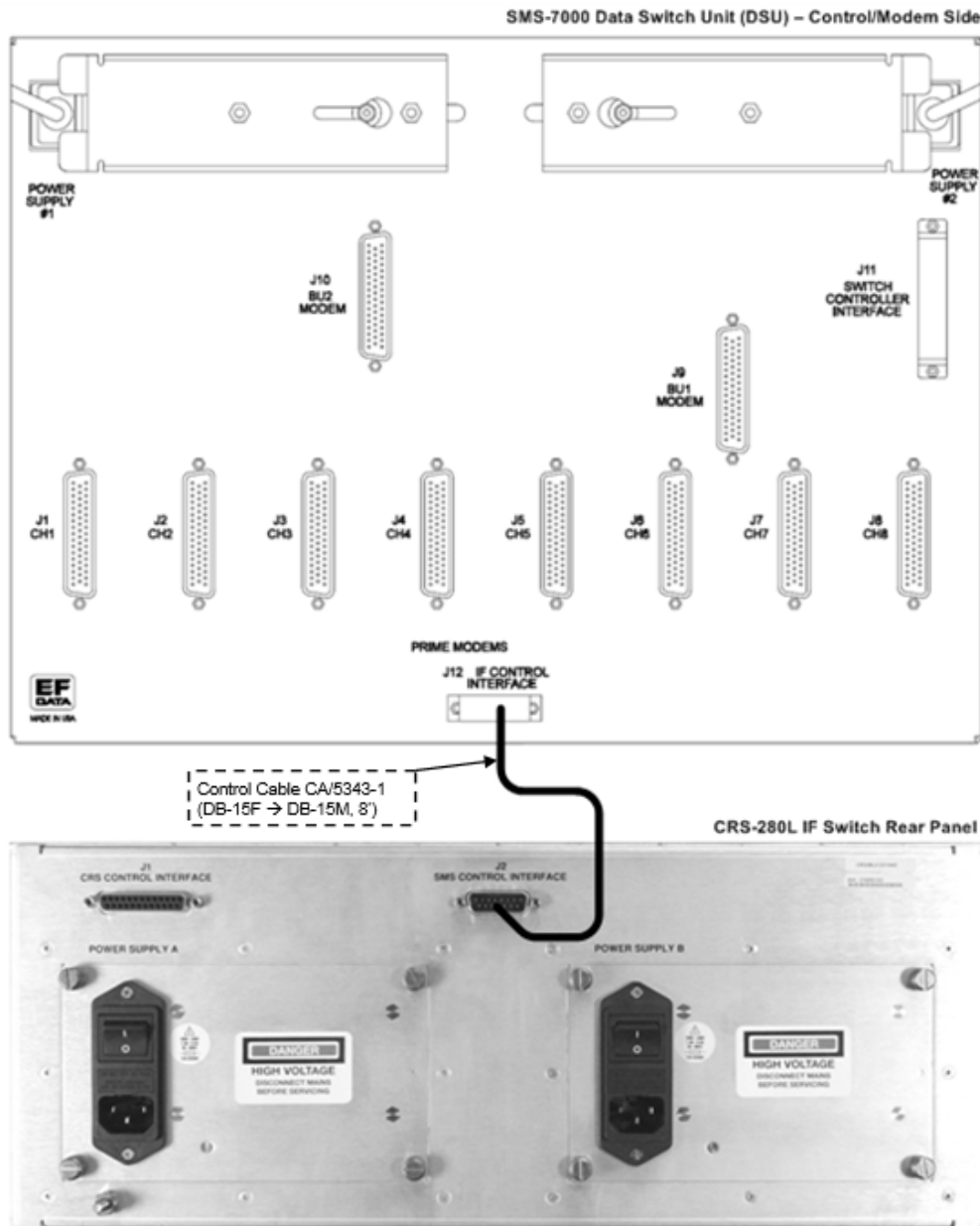

Figure 4-1. SMS-7000 to CRS-280L Control Cable Connection



The Comtech EF Data SMS-7000 1:8 Modem Protection Switch is a legacy product that is no longer in production.

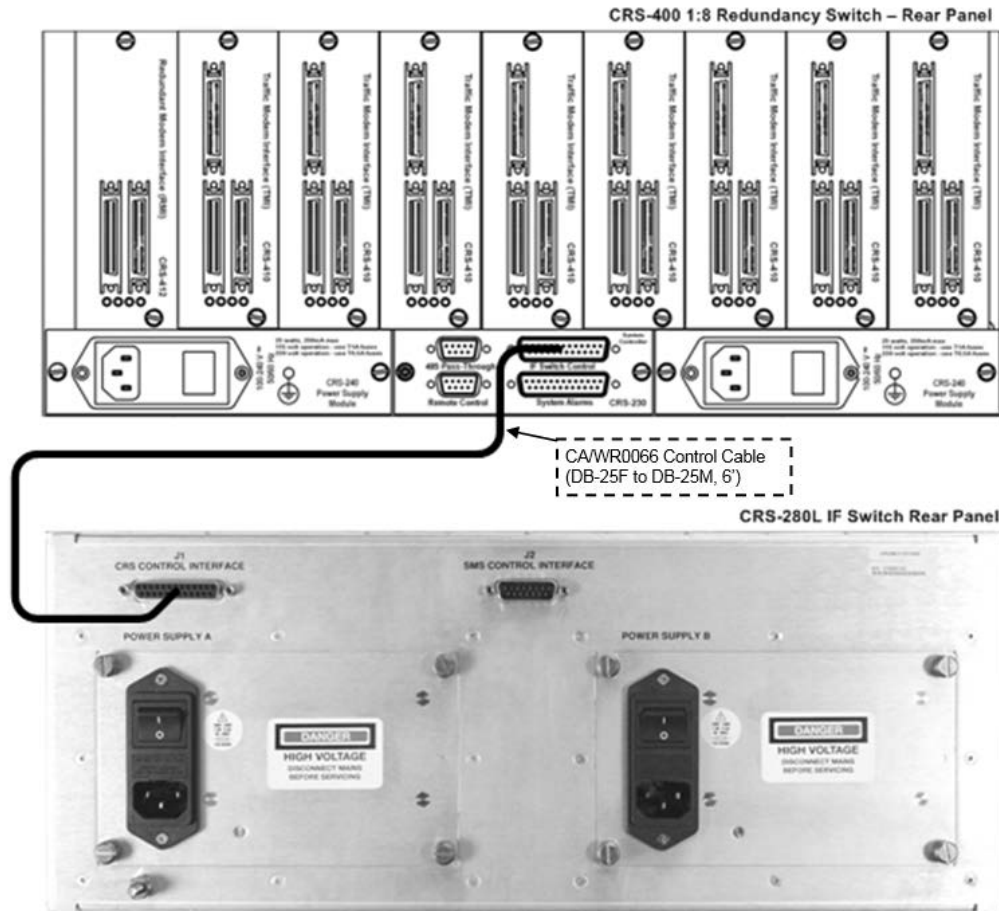

Figure 4-2. CRS-400 to CRS-280L Control Cable Connection



The Comtech EF Data CRS-400 1:8 Redundancy Switch is a legacy product that is no longer in production.

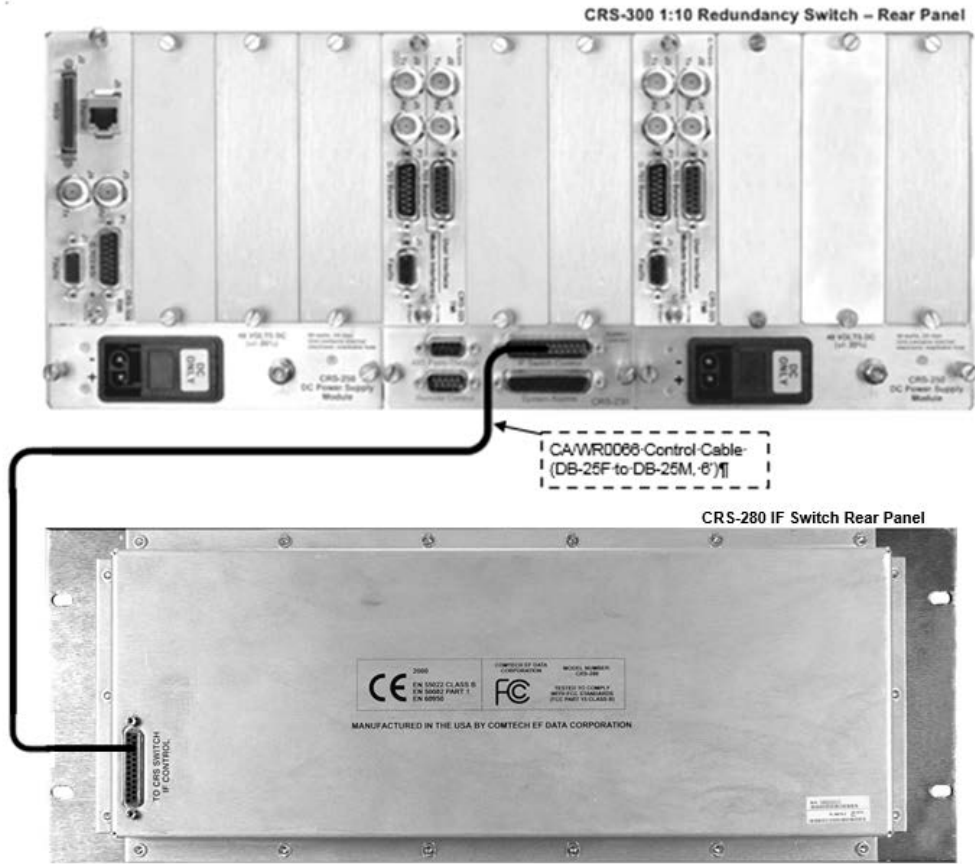

Figure 4-3. CRS-300 to CRS-280 Control Cable Connection

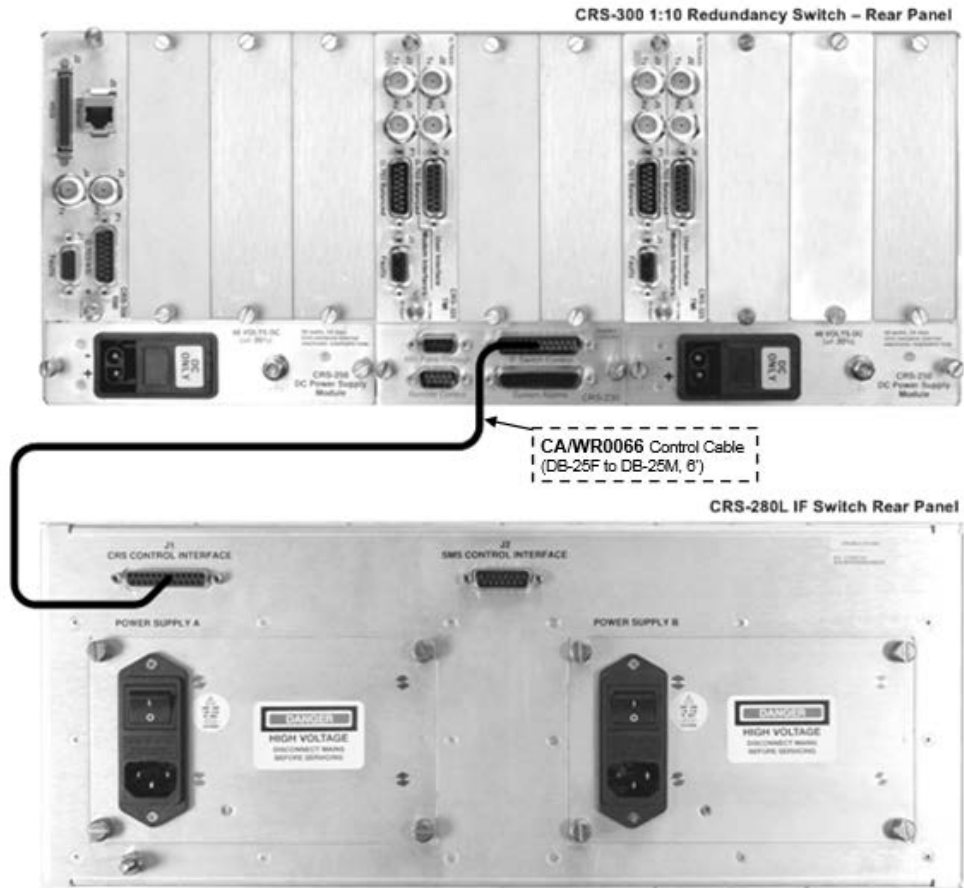

Figure 4-4. CRS-300 to CRS-280L Control Cable Connection

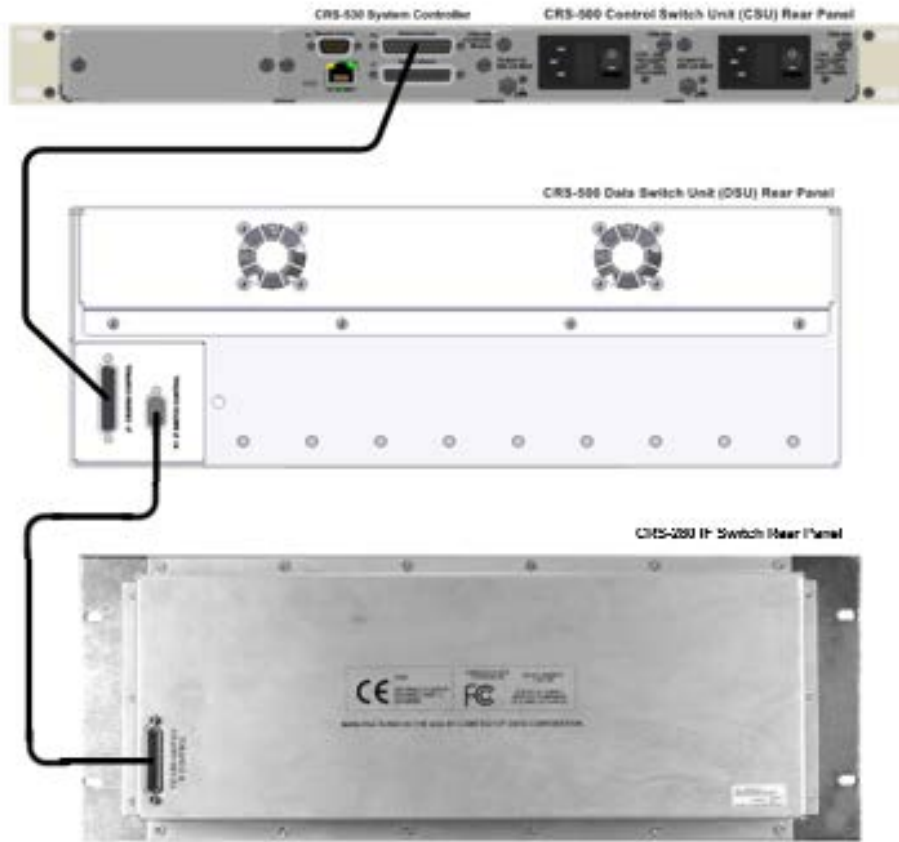

Figure 4-5. CRS-500 to CRS-280 Control Cable Connection

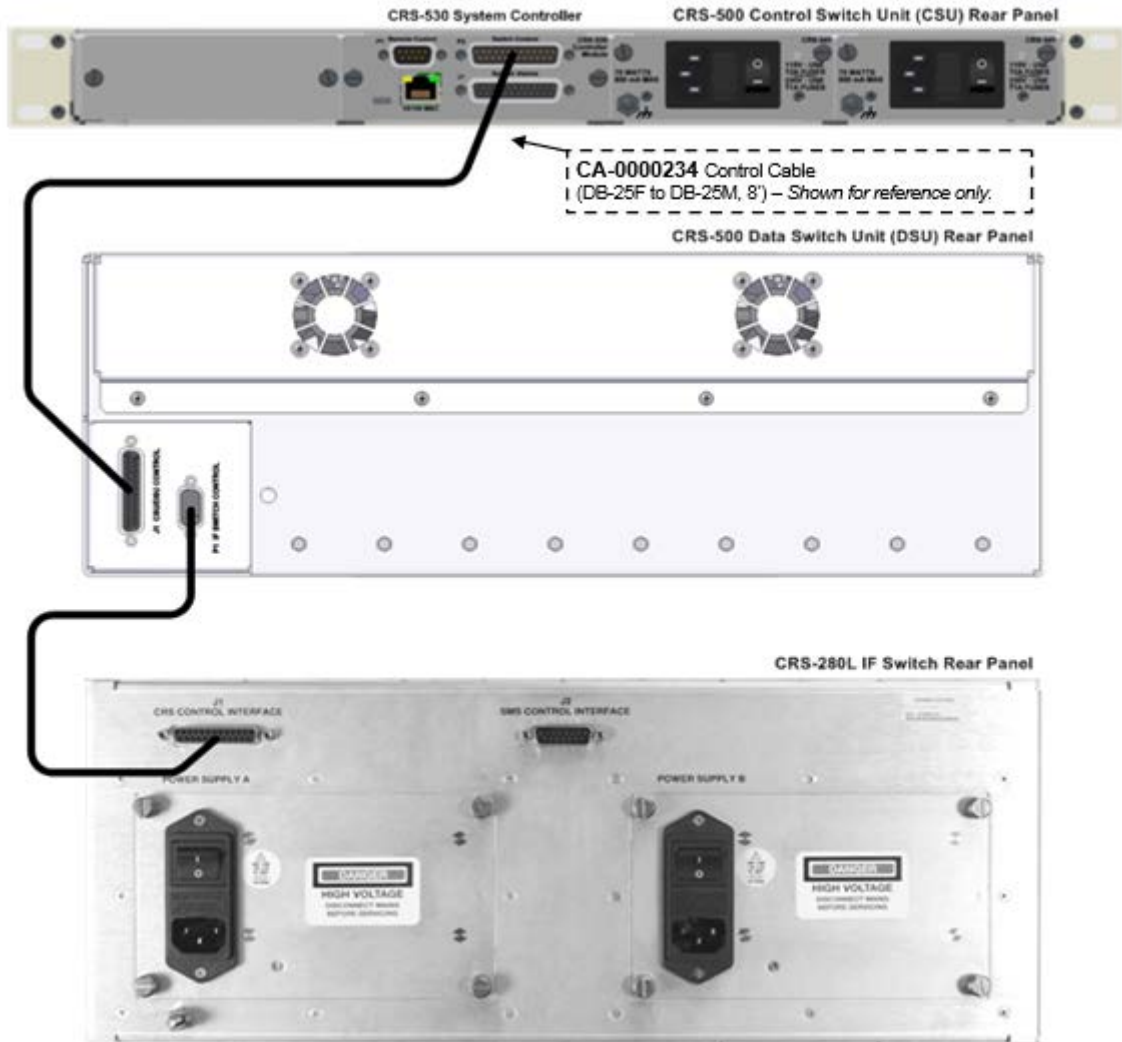

Figure 4-6. CRS-500 to CRS-280L Control Cable Connection

4.3 Cable Connections

4.3.1 CRS-280 IF Cable Connections

Frequency, Impedance	Connector Type	CEFD Cable
70/140 MHz, 50Ω	BNC female	PL/0946-2
70/140 MHz, 70Ω	BNC female	PL/0813-8

4.3.2 CRS-280L L-Band IF Cable Connections

Cables for connecting the CRS-280L L-Band IF Switch to the L-Band modems within the redundancy system are available for purchase from Comtech EF Data and can be ordered at the same time the order is placed for the CRS-280L:

CEFD Part No.	Description
CA/RF10453-2	Cable Assembly, L-Band 50Ω, Type 'N' male to Type 'N' male connectors, 2'
CA/RF10453-4	Cable Assembly, L-Band 50Ω, Type 'N' male to Type 'N' male connectors, 4'
CA/RF10453-6	Cable Assembly, L-Band 50Ω, Type 'N' male to Type 'N' male connectors, 6'
CA/RF10453-8	Cable Assembly, L-Band 50Ω, Type 'N' male to Type 'N' male connectors, 8'

4.3.3 L-Band IF Cable Characteristics



If L-Band cables are not purchased from Comtech EF Data, use of a suitable equivalent is recommended.

Cable Type	Loss at 1 GHz	Loss at 2 GHz
Semflex BPE200 (or equivalent)	0.11 dB/ft	0.15 dB/ft

4.3.4 L-Band Switch-to-Modem Cabling Requirements

The number of cables required depends on the switch system configuration. Per the example shown at right, each modem connected to the CRS-280L front panel requires two L-Band cables:

- One cable for the Rx L-Band connection
- One cable for the Tx L-Band connection

Each cable must be connected and secured using the Type 'N' threaded female connectors on the front panel of the CRS-280L and rear panel of the L-Band modems.



Cable connections are defined as follows:

L-Band Modem Connection		CRS-280L Connection	Comments
Redundant Modem	TX Output ↔	TX Backup (TX In)	
	RX Input ↔	RX Backup (RX Out)	
Prime Modem #1	TX Output ↔	TX 1 (TX In)	
	RX Input ↔	RX 1 (RX Out)	
Prime Modem #2	TX Output ↔	TX 2 (TX In)	
	RX Input ↔	RX 2 (RX Out)	
Prime Modem #3	TX Output ↔	TX 3 (TX In)	
	RX Input ↔	RX 3 (RX Out)	
Prime Modem #4	TX Output ↔	TX 4 (TX In)	
	RX Input ↔	RX 4 (RX Out)	
Prime Modem #5	TX Output ↔	TX 5 (TX In)	
	RX Input ↔	RX 5 (RX Out)	
Prime Modem #6	TX Output ↔	TX 6 (TX In)	
	RX Input ↔	RX 6 (RX Out)	
Prime Modem #7	TX Output ↔	TX 7 (TX In)	
	RX Input ↔	RX 7 (RX Out)	
Prime Modem #8	TX Output ↔	TX 8 (TX In)	
	RX Input ↔	RX 8 (RX Out)	
Prime Modem #9	TX Output ↔	TX 9 (TX In)	
	RX Input ↔	RX 9 (RX Out)	
Prime Modem #10	TX Output ↔	TX 10 (TX In)	
	RX Input ↔	RX 10 (RX Out)	

4.3.5 L-Band Uplink/Downlink Cable Connections



The CRS-280L is not designed to convey DC power to external equipment such as LNBS or BUCs. Do not apply DC power to the L-Band input and output (Type 'N') ports of the switch.

CEFD recommends that connections to uplink and downlink equipment be made after all other system cabling and configuration is complete. Cabling to and from the CRS-280L uplink and downlink ports is dependant on the system configuration and the uplink/downlink equipment used. For additional information, refer to the uplink/downlink equipment documentation.

Chapter 5. REDUNDANCY SYSTEM CONFIGURATION / OPERATION

5.1 Overview



In order to avoid damage to the modems, the companion redundant switch, and the CRS-280L L-Band IF Switch, and it is important for the user to follow this sequence of configuration:

- ***First, connect cables between the (powered OFF) modems, companion redundancy switch, and CRS-280L as outlined previously in Chapter 4. CABLES AND CONNECTIONS.***
- ***Second, configure the modems for 1:N redundant operation, as outlined in the respective modem and companion switch Installation and Operation Manuals.***
- ***Third, once the modems have been properly configured for 1:N redundant operations, the user should follow the instructions in the next two chapter sections in the sequence they are presented.***

5.2 CRS-280L Input Power Cord Connections



Do not turn the CRS-280L power supply switches to the on position until all system connections are in place.

Connect the AC power cords as follows:

Step	Instructions
1	Ensure that both power supply switches are in the off position before connecting the power supply power cords.
2	Each CRS-280L is supplied with two power cords – one for each power supply power input. Connect the female end of each supplied power cords to its mating socket.
3	Plug both power cords into the AC power source.

5.3 CRS-280L 1:N Redundancy System Power-up Sequence

After the 1:N redundant system cabling is complete, and the companion switch and modems have been initially configured, the complete system may be powered up. The typical equipment power-up sequence is as follows:

Step	Instructions
1	Turn on the redundant and traffic L-Band modems.
2	Power up the CRS-280L L-Band IF Switch switch by turning both power supply switches, located on the CRS-280L rear panel, to the on position. Once the power supplies are turned on, both power status LEDs (A and B) on the front panel should illuminate green .
3	Power up the companion switch as applicable (e.g., turn on the system controller / data switch for the CRS-300, CRS-400, or SMS-7000; turn on the CRS-500 Control Switch Unit (CSU), etc.)



The CRS-280L is designed to operate with only one power supply energized. However, it is recommended to continually operate the system with both supplies energized for redundancy.

5.3.1 CRS-280L Operations with the CRS-500 M:N Redundancy System

While the CRS-500 M:N Redundancy System supports 2:N redundancy and IP Sub-MUX operation, the CRS-280L L-Band IF Switch is limited to 1:10 (maximum) redundancy – **2:N redundancy and IP Sub-MUX operation are not supported by the CRS-280L.**

Appendix A. CABLE DRAWINGS

A.1 Introduction

This appendix contains drawings of cables used with the CRS-280 (70/140 MHz) and the CRS-280L (L-Band) IF Switch for 1:N Redundancy. These cables are broken into two categories – Control Interface Cables and IF Interface Cables:

- The Control Interface Cables are used to connect the CRS-280L rear panel J1 CRS Control Interface or J2 SMS Control Interface connector to its companion redundancy switch IF Switch Control Interface connector.
- The IF Interface Cables may be selected and used to connect the CRS-280L, via the front panel Tx/Rx Type 'N' threaded female connectors, to the Redundant Modem and up to 10 traffic modems that are part of the 1:N redundancy setup, as well as to any external uplink / downlink RF equipment.

Each section provides illustrations of the cables' technical specifications; additionally, the table in each section cross-reference to the illustrations found in **Chapter 4. CABLES AND CONNECTIONS**.

A.2 Control Interface Cables

App. A FIG	REF Ch. 4 FIG	CEFD Cable P/N	Description	Used For...
A-1	4-1	CA/5343-1	Control Cable, DB-15F → DB-15M, 8'	CRS-280L → SMS-7000 Data Switch Unit (DSU)
A-2	4-2, 4-3	CA/WR0066	Control/Data Cable, DB-25F → DB-25M, 6'	CRS-280L → CRS-400/CRS-300
A-3	4-4	CA-0021666	Control Cable, DB-25M → DB-9F, 8'	CRS-280/280L → CRS-500 Data Switch Unit (DSU)



The Comtech EF Data SMS-7000 1:8 Modem Protection Switch and CRS-400 1:8 Redundancy Switch are legacy products that are no longer in production.

A.2.1 SMS-7000 Control Cable

WIRE LIST	
FROM	TO
P1-1	J1-1
P1-2	J1-2
P1-3	J1-3
P1-4	J1-4
P1-5	J1-5
P1-6	J1-6
P1-7	J1-7
P1-8	J1-8
P1-9	J1-9
P1-10	J1-10
P1-11	J1-11
P1-12	J1-12
P1-13	J1-13
P1-14	J1-14
P1-15	J1-15

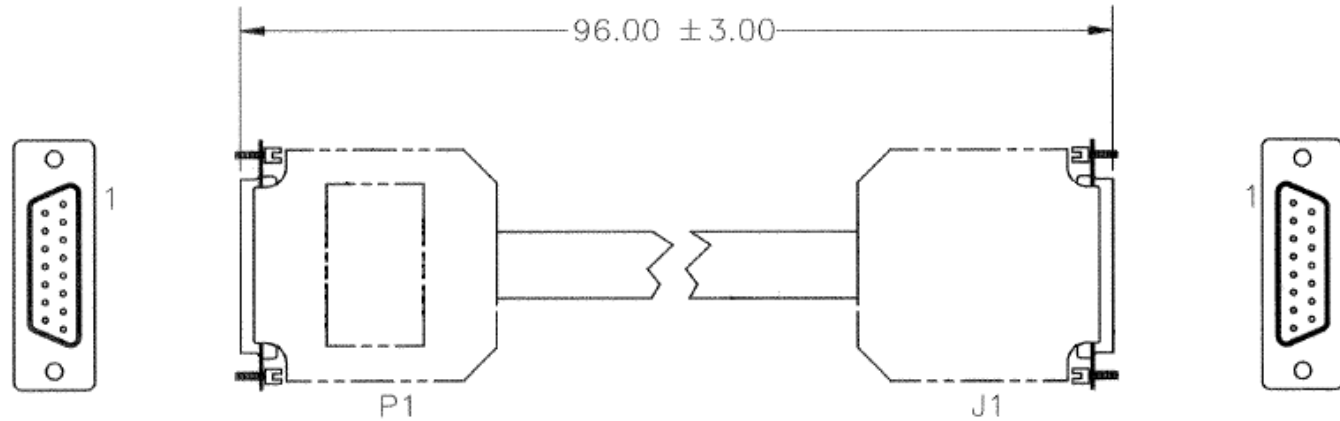

The Comtech EF Data SMS-7000 1:8 Modem Protection Switch is a legacy product that is no longer in production.

Figure A-1. CRS-280L → SMS-7000 Data Switch Unit (DSU) Control Cable (CEFD P/N CA/5343-1)

A.2.2 CRS-400/CRS-300 Control Cable

INDICATORS		
25M	NOTES	25F
1	TO	1
2	TO	2
3	TO	3
4	TO	4
5	TO	5
6	TO	6
7	TO	7
8	TO	8
9	TO	9
10	TO	10
11	TO	11
12	TO	12
13	TO	13
14	TO	14
15	TO	15
16	TO	16
17	TO	17
18	TO	18
19	TO	19
20	TO	20
21	TO	21
22	TO	22
23	TO	23
24	TO	24
25	TO	25

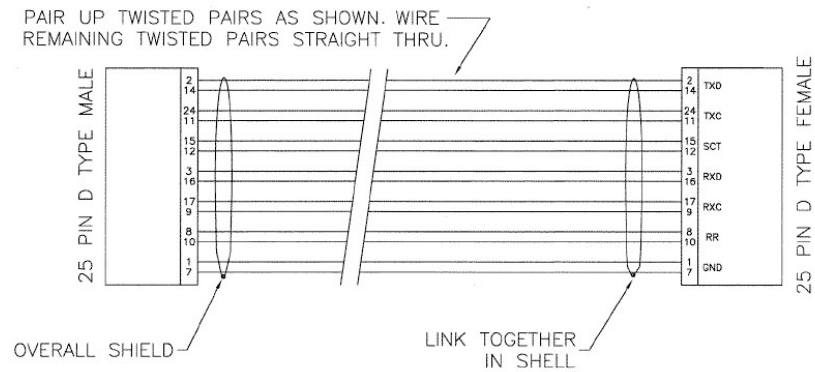
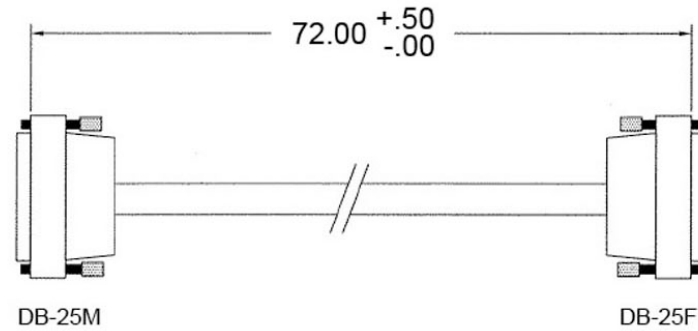

The Comtech EF Data CRS-400 1:8 Redundancy Switch is a legacy product that is no longer in production.

Figure A-2. CRS-280L → CRS-400, CRS-300 Control Cable (CEFD P/N CA/WR0066)

A.2.3 CRS-500 Control Cable

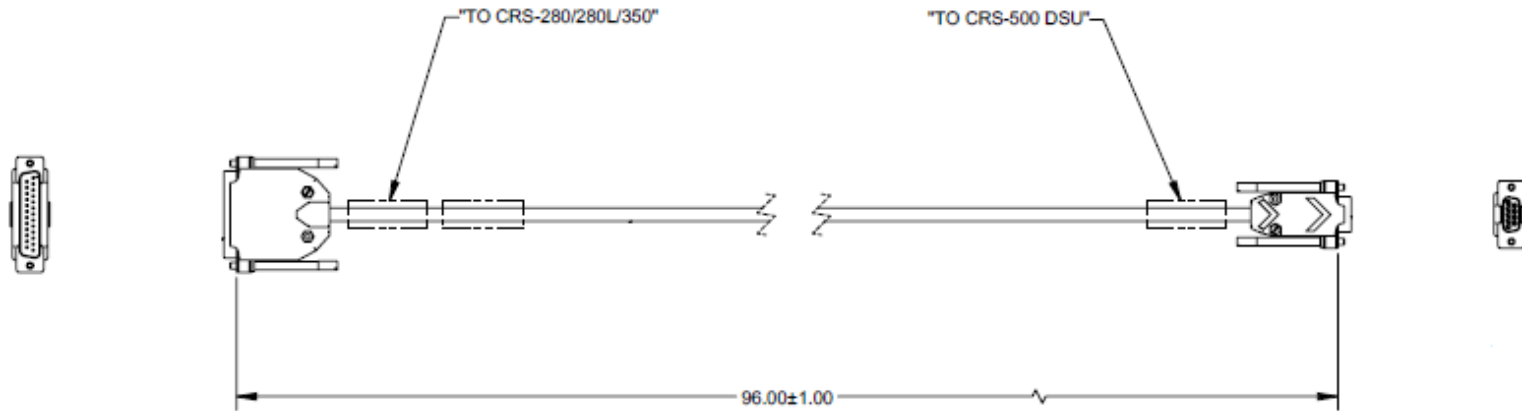

WIRE LIST			
FROM	TO	WIRE COLOR	NOTES
P1-11	J1-1	SHIELD WIRE/BACKSHELL	ALSO SEE DETAIL A
P1-21	J1-2	RED	TWISTED PAIR
P1-17	J1-3	BLK	
P1-2	J1-4	BLU	TWISTED PAIR
P1-10	J1-5	BLK	TWISTED PAIR
P1-5	J1-6	GRN	
P1-4	J1-7	BLK	TWISTED PAIR
P1-16	J1-8	WHT	TWISTED PAIR
P1-12	J1-9	BLK	

Figure A-3. CRS-280/280L → CRS-500 Data Switch Unit (DSU) Control Cable (CEFD P/N CA-0021666)

A.3 IF Interface Cable, Type 'N' 50Ω

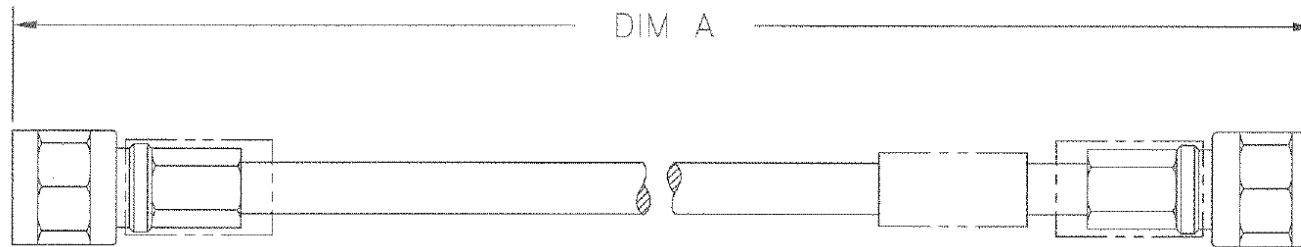

CEFD P/N	DIM 'A'
CA/RF10453-2	24.00 ± .80
CA/RF10453-4	48.00 ± 1.50
CA/RF10453-6	72.00 ± 3.00
CA/RF10453-8	96.00 ± 3.00

Figure A-4. Type 'N' 50Ω IF Coax Cable (CEFD P/N CA/RF10453-x)

Appendix B. CRS-280L POWER SUPPLY MODULE REPLACEMENT

B.1 Introduction

The CRS-280L L-Band IF Switch for 1:N Redundancy features dual power supply modules: the standard AC module (CEFD P/N PI/10207-1), or the optional DC module (CEFD P/N PL 0000355). These modules are the only field replaceable components in the CRS-280L.

This appendix illustrates the procedure required to remove and install a CRS-280L power supply module (Figure B 1) into any CRS 280L L-Band IF Switch unit.

Unless otherwise noted, while the illustrations throughout this appendix visually depict the replacement of a standard PL/10207-1 AC Power Supply Module, this procedure is typical for removing and installing either a standard AC or optional DC power supply module into the applicable A or B compartment in the rear of the CRS 280L chassis.

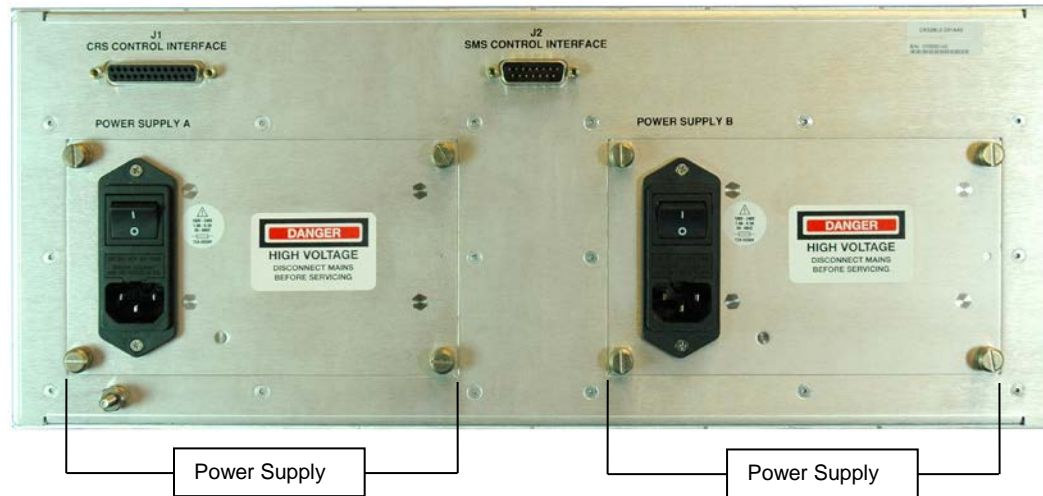

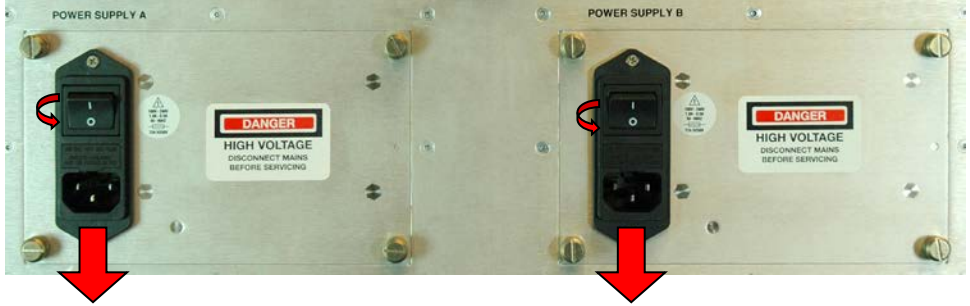
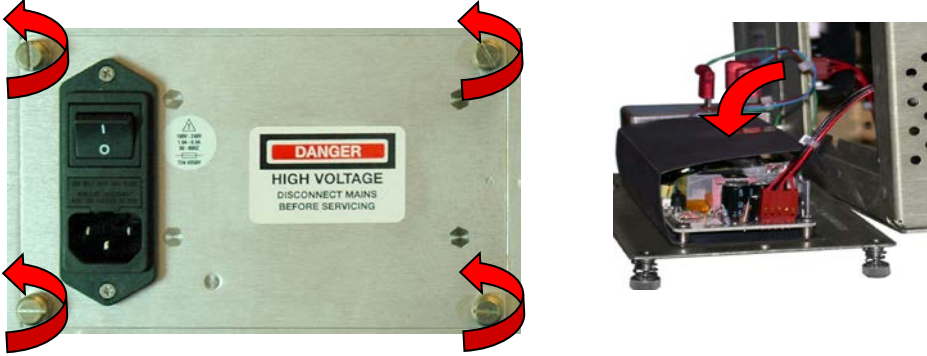
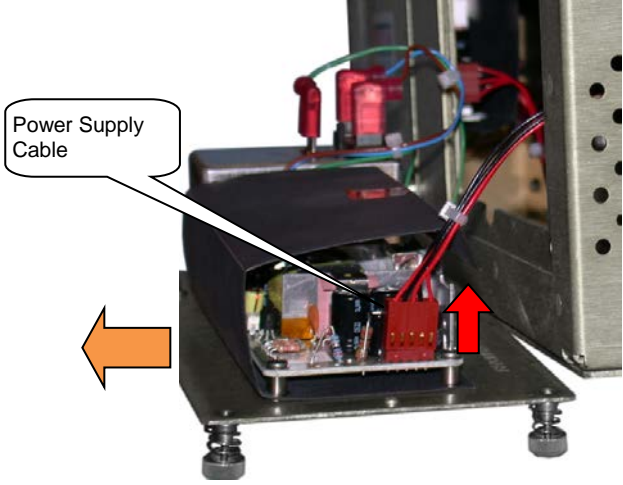

Figure B-1. CRS-280L Rear Panel (shown with PL/10207-1 AC Modules)

B.2 Power Supply Module Removal Procedure

Step	Task	
1	<p> DISCONNECT THE CRS-280L FROM ITS POWER SOURCE!</p> <p>For AC Units (pictured): Shut off the AC power switch on both power supply modules and disconnect both power cords from their receptacles.</p> <p>For DC Units: Make sure to disconnect both power cords from their DC power sources, then unscrew the positive, negative, and ground leads from the terminal block of the module being replaced.</p>	
2	<p>Loosen the four captive mounting screws of the module to be replaced, then carefully pull the module plate away from the unit.</p>	

Step	Task	
3	Carefully remove the Power Supply Cable from its mating connector on the old power supply module PCB, then set the old power supply module aside.	 <p>The diagram shows a power supply module with its cover removed. A callout box labeled 'Power Supply Cable' points to a red cable connected to a mating connector on the PCB. A red arrow points upwards at the connector, and an orange arrow points to the left, indicating the direction to move the module.</p>

B.3 Power Supply Module Installation Procedure

Step	Task	
1	Identify for assembly the Power Supply Cable (connected to the CRS-280L chassis PCB), and its mating connector on the new power supply module PCB.	

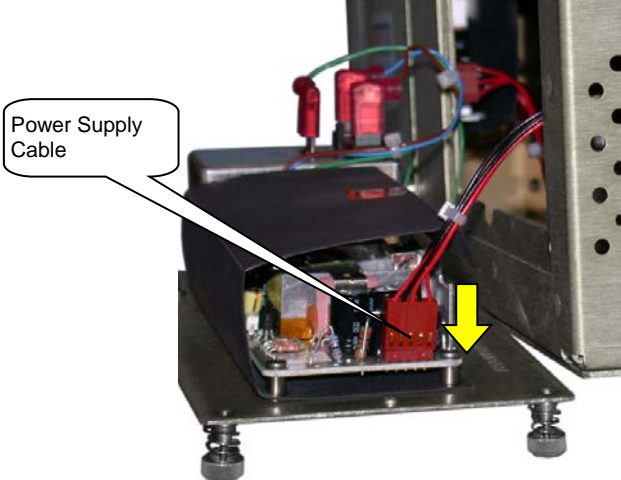
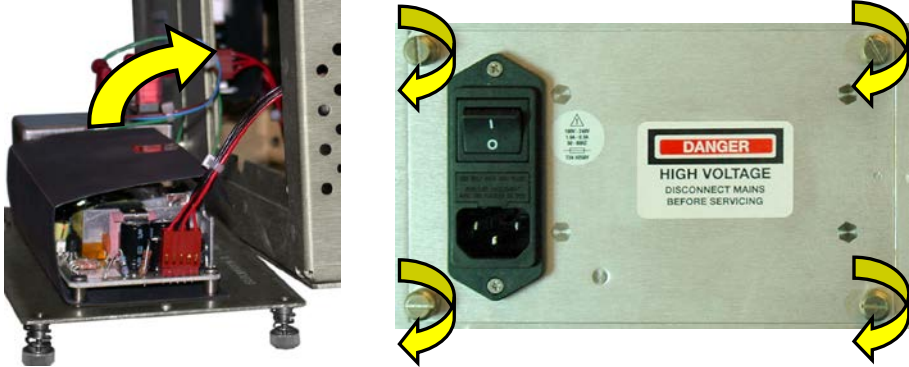
Step	Task	
2	Carefully reconnect the Power Supply Cable to its mating connector on the new power supply module PCB.	
3	Assemble the power supply module plate to the CRS-280L chassis, taking care not to crimp the Power Supply Cable when doing so, then tighten the four captive mounting screws of the module to secure the module in place.	

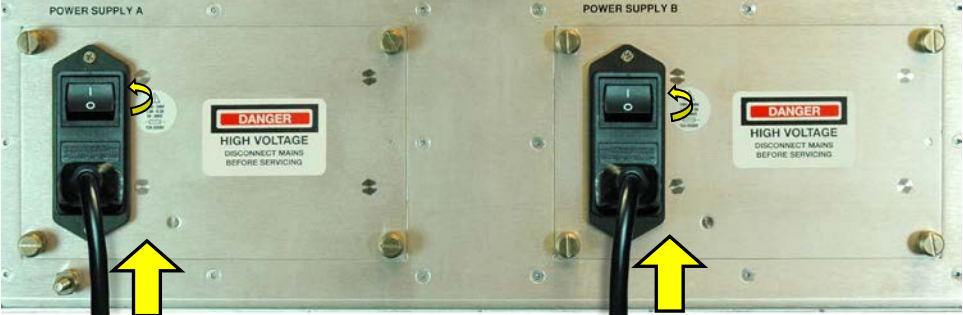
Step	Task	
4	<p>For AC Units (pictured): Reconnect the power cords for both power supply modules. The AC power may be switched on to both power supply modules once all control and IF cabling connections have been confirmed.</p> <p>For DC Units: Screw on the positive, negative, and ground leads to the terminal block of the replacement power supply module. The unit may be reconnected to both DC power sources once all control and IF cabling connections have been confirmed.</p>	

The module installation has been completed and the CRS-280L L-Band Switch for 1:N Redundancy is ready for operation.

BLANK PAGE



2114 WEST 7TH STREET TEMPE ARIZONA 85281 USA
480 • 333 • 2200 PHONE
480 • 333 • 2161 FAX