

## Decorator Keypads

- > Decorator-style wall mount keypads
- > Available in 6, 8, and 12 button configurations
- > Customizable button engraving
- > Red LED feedback indicators
- > Mount using standard electrical gang boxes and faceplates
- > Available in smooth almond, black, and white finishes
- > Cresnet® wired communications



Crestron® C2N-DB Decorator Series keypads deliver simple, versatile pushbutton control for a broad range of residential and commercial applications. Clean, contemporary styling lends an attractive and unimposing appearance to any interior design, and affords convenient electrical box installation in perfect harmony with other wall mount devices. They are offered in smooth white, almond, and black finishes, each formulated to match perfectly with popular off-the-shelf faceplates<sup>[1]</sup>.

Available in configurations of 6, 8, or 12 buttons, the Decorator keypads are designed for installation using standard electrical gang boxes and decorator-style faceplates<sup>[1]</sup>. Multiple keypads can easily be ganged side-by-side along with other wall mount devices.

Custom engraving of the buttons is available to provide clear designation of each button's function. Every button is accompanied by an LED indicator, providing true status feedback for the most reliable operation. And, every button and LED is fully programmable for virtually any custom functionality, making C2N-DB Decorator Keypads perfect for controlling room lighting and shades, audio and video equipment, or any other application that demands simple, immediate one-touch control.

*Please note, the almond smooth (-A-S) and white smooth (-W-S) finishes currently offered are not the same as on older almond (A) and white (W) models. When ordering, please be sure to specify the model number exactly as shown in the price list. If you require buttons or keypads to match the older almond or white finishes, please contact your Crestron representative.*

## SPECIFICATIONS

### Buttons

**Keypad Buttons:** (6, 8 or 12 depending upon model) programmable pushbuttons

**Button Caps:** Includes blank button caps. Custom engraved button caps available separately<sup>[2]</sup>.

### Indicators

**Feedback:** (1 per button) red LED, programmable, software-adjustable intensity

### Connectors

**NET:** (1) 4-pin 3.5mm detachable terminal block; Cresnet slave port, connects to Cresnet control network

### Power Requirements

**Cresnet Power Usage:** 3 Watts (0.125 Amps @ 24 Volts DC)

### Environmental

**Temperature:** 32° to 113°F (0° to 45°C)

**Humidity:** 10% to 90% RH (non-condensing)

### Construction

**Chassis:** Plastic

**Mounting:** Mounts in a 1-gang or larger electrical box or mud ring

**Faceplate:** Requires decorator style faceplate (not included)

### Dimensions

**Height:** 4.16 in (106 mm) without faceplate

**Width:** 1.79 in (46 mm) without faceplate

**Depth:** 1.53 in (39 mm)

### Weight

2.6 oz (75 g)

# C2N-DB Decorator Keypads

## MODELS & ACCESSORIES

### Available Models

---

**C2N-DB6-A-S:** Decorator Keypad, 6-Buttons, Almond Smooth

**C2N-DB6B:** Decorator Keypad, 6-Buttons, Black Smooth

**C2N-DB6-W-S:** Decorator Keypad, 6-Buttons, White Smooth

**C2N-DB8-A-S:** Decorator Keypad, 8-Buttons, Almond Smooth

**C2N-DB8B:** Decorator Keypad, 8-Buttons, Black Smooth

**C2N-DB8-W-S:** Decorator Keypad, 8-Buttons, White Smooth

**C2N-DB12-A-S:** Decorator Keypad, 12-Buttons, Almond Smooth

**C2N-DB12B:** Decorator Keypad, 12-Buttons, Black Smooth

**C2N-DB12-W-S:** Decorator Keypad, 12-Buttons, White Smooth

### Available Accessories

---

**DB6-BTN:** Engravable Button Cap for C2N-DB6 and C2N-DB8 [specify color]

**DB12-BTN:** Engravable Button Cap for C2N-DB12 and C2N-DB8 [specify color]

**CRESNET-NP:** Cresnet® Control Cable, non-plenum

**CRESNET-P:** Cresnet® Control Cable, plenum

**CCR-L-1:** Crestron® Color Ring

#### Notes:

1. Faceplate not included.
2. For C2N-DB8, use (4) DB6-BTN and (4) DB12-BTN.

This product may be purchased from an authorized Crestron dealer. To find a dealer, please contact the Crestron sales representative for your area. A list of sales representatives is available online at [www.crestron.com/salesreps](http://www.crestron.com/salesreps) or by calling 800-237-2041.

The specific patents that cover Crestron products are listed online at: [patents.crestron.com](http://patents.crestron.com).

Crestron, the Crestron logo, and Cresnet are either trademarks or registered trademarks of Crestron Electronics, Inc. in the United States and/or other countries. Other trademarks, registered trademarks, and trade names may be used in this document to refer to either the entities claiming the marks and names or their products. Crestron disclaims any proprietary interest in the marks and names of others. Crestron is not responsible for errors in typography or photography. Specifications are subject to change without notice. ©2013 Crestron Electronics, Inc.

# C2N-DB Decorator Keypads

## C2N-DB6

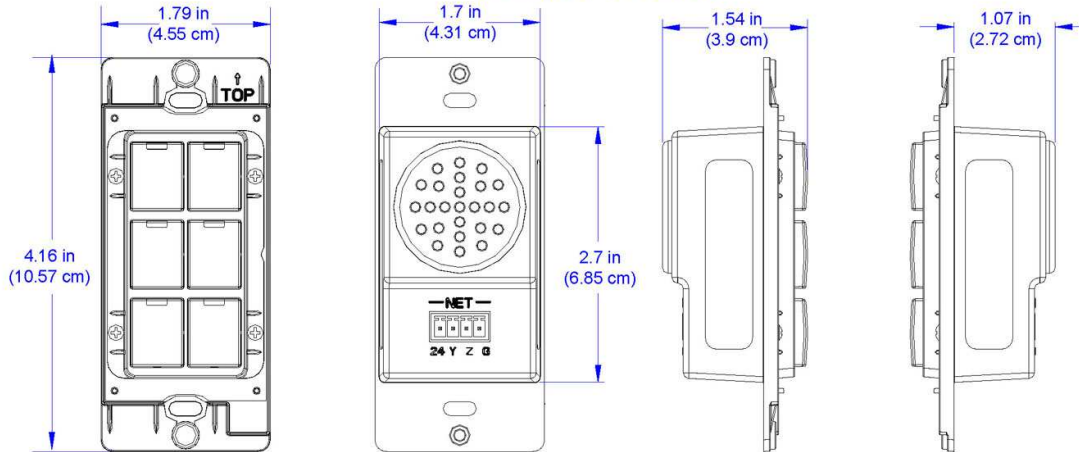

## C2N-DB8

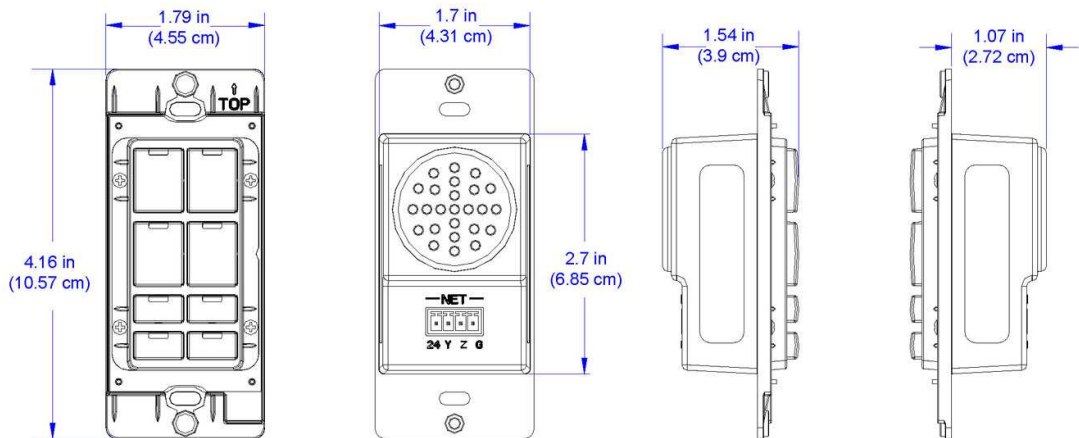

## C2N-DB12

