

Ethernet Switches

- » Hardened Ethernet Switches
- » Fiber Intelligent Ethernet Switches
- » Fiber Optic Modulized Ethernet Switches
- » Gigabit Ethernet Switches
- » Ethernet Switches with SFP
- » PoE Ethernet Switches

— *IEC61850-3 / IEEE1613 Products
for the Grids and Substations*



EX72000 Series	
Hardened Managed 8 to 14 ports 10/100BASE and 2-port Gigabit Ethernet Switch with SFP options	93
EX71000 Series	
Hardened Managed 8-port 10/100BASE and 2-port Gigabit Ethernet Switch with SFP options	98
EX74000 Series	
Hardened Managed 6-port 10/100BASE (4 x PoE) with 2-port SFP (DDM) Gigabit combo Ethernet Switch.....	104
Hardened Web-Smart Ethernet Switch	109
EX48000 Series	
Hardened Web-Smart 5-port 10/100BASE PoE (4 x PoE) Ethernet Switch.....	109
EX46100 Series	
Hardened Web-smart 8-port 10/100BASE High Power PoE (4 x PoE) Ethernet Switch	112
EX49000 Series	
Hardened Web-smart 16-port 10/100BASE PoE and 2-port Gigabit Ethernet Switch.....	116
Hardened Unmanaged Ethernet Switches	119
EX49000A Series	
Hardened Unmanaged 16-port 10/100BASE PoE and 2-port Gigabit Ethernet Switch	119
EX42900 Series	
Hardened Unmanaged 5/8-port 10/100/1000BASE Gigabit Ethernet Switch.....	122
EX42300 Series	
Hardened Unmanaged 5/6 port Ethernet Switch.....	125
4-port 10/100BASE (4 x PoE) + 1-port 10/100/1000BASE-T	125
Optional 1-port 1000BASE-X Gigabit	125
EX45900 Series	
Hardened Unmanaged 5-port 10/100/1000BASE (4 x PoE) + 1-port 1000BASE-X Gigabit Ethernet Switch.....	128
EX47000 Series	
IEC61850-3/IEEE1613 Hardened Unmanaged 8-port 10/100BASE Ethernet Switch.....	131
EX45000 Series	
Hardened Unmanaged 8-port 10/100BASE PoE (4 x PoE) Ethernet Switch.....	135
EX94000 Series	
Hardened Unmanaged 8-port 10/100BASE Ethernet Switch.....	139
EX95000 Series	
Hardened Unmanaged 16-port 10/100BASE Ethernet Switch.....	143
EX48000A Series	
Hardened Unmanaged 5-port 10/100BASE PoE (4 x PoE) Ethernet Switch.....	147

Industrial Managed Ethernet Switches	150
EX27000 Series	
IEC61850-3/IEEE1613 Managed 24-port 10/100BASE and 4-port Gigabit Ethernet Switch with SFP options	150
EX29000 Series	
IEC61850-3/IEEE1613 Modulized Managed 24-port 10/100BASE and 4-port Gigabit Ethernet Switch with SFP options	156
EX63000 Series	
Industrial Managed 16-port 10/100BASE with 2-port Gigabit combo Ethernet Switch	162
EX61000A Series	
Industrial Managed 8-port 10/100BASE and 2-port Gigabit Ethernet Switch with SFP options.....	168
EX62000 Series	
Industrial Managed 8 to 14 ports 10/100BASE and 2-port Gigabit Ethernet Switch with SFP options.....	174
Industrial Web-Smart Ethernet Switches	179
EX38000 Series	
Industrial Web-Smart 5-port 10/100BASE PoE (4 x PoE)Ethernet Switch.....	179
Industrial Unmanaged Ethernet Switches	182
EX39924 Series	
Industrial Unmanaged 24-port Gigabit Switch with 4/16-port combo SFP Slots.....	182
EX32900 Series	
Industrial Unmanaged 5/8-port 10/100/1000BASE Gigabit Ethernet Switch	185
EX35000 Series	
Industrial Unmanaged 8-port Gigabit Ethernet Switch.....	188
EX33000 Series	
Industrial Unmanaged 16-port 10/100BASE Ethernet Switch	192
EX34000 Series	
Industrial Unmanaged 8-port 10/100BASE PoE (4 x PoE) Ethernet Switch	196
EX43000 Series	
Industrial Unmanaged 8-port 10/100BASE Ethernet Switch	200
EX42000 Series	
Industrial Unmanaged 5-port 10/100BASE Ethernet Switch	204
EX24402	
Managed 16-port 10/100BASE PoE with 2-port Gigabit SFP Combo Ethernet Switch	208

Commercial Managed Ethernet Switches 212

EX26262	
Web-managed 26-port Gigabit PoE Switch with 24 Gigabit + 2 SFP ports.....	212
EX26182	
Web-Managed 18-port Gigabit PoE Switch with 16 Gigabit + 2 SFP ports.....	216
EX25611	
Managed 24-port 10/100/1000BASE-T (4-port SFP Combo) and 4-port 1G/10G SFP+ Ethernet Switch	220

Commercial Web-Smart Ethernet Switches 224

EX17242 Series	
Web-smart 24-port 10/100BASE-TX PoE and 2-port combo Gigabit SFP Ethernet Switch.....	224
EX1616W Series	
Web-Smart 16-port 10/100BASE-TX and 1-port 100BASE-FX Ethernet Switch.....	226
EX17008	
Web-smart 8-port 10/100BASE-TX PoE Ethernet Switch	229
EX17016	
Web-smart 16-port 10/100BASE-TX PoE Ethernet Switch	231
EX17082	
Web-Smart 8-port 10/100BASE-TX PoE (IEEE802.3at) and 2-port combo Gigabit SFP Ethernet Switch	233
EX17162	
Web-smart 16-port 10/100BASE-TX PoE and 2-port combo Gigabit SFP Ethernet Switch.....	235
EX17908	
Web-smart 8-port 10/100/1000BASE-T PoE Ethernet Switch	238

Commercial Unmanaged Ethernet Switches 240

EX17162A	
Unmanaged 16-port 10/100BASE-TX PoE and 2-port combo Gigabit SFP Ethernet Switch.....	240
EX17044A	
Unmanaged 8-port 10/100BASE-TX (4 x PoE) Ethernet Switch.....	243
EX17016A	
Unmanaged 16-port 10/100BASE-TX PoE Ethernet Switch	245
EX17082A	
Unmanaged 8-port PoE (IEEE802.3at) 10/100BASE-TX and 2-port combo Gigabit SFP Ethernet Switch.....	247
EX17908A	
Unmanaged 8-port 10/100/1000BASE-T PoE Ethernet Switch	249
EX17008A	
Unmanaged 8-port 10/100BASE-TX PoE Ethernet Switch	251

EX16916 Series	
Unmanaged 16-port Gigabit Ethernet Switch.....	253
EX16926 Series	
Unmanaged 26 Port Gigabit Switch with 24 RJ45 Gigabit Ports and 2 Gigabit SFP Slots	256
EX16900 Series	
Unmanaged 5/8-port 10/100/1000BASE Ethernet Switch	259
EX1605PB/PBF1 Series	
EX1608PB/PBF1 Series (US Only)	
Unmanaged 5/8-port 10/100BASE Ethernet Switch.....	262
EX1608SF Series	
Unmanaged 8-port 10/100BASE Ethernet Switch.....	265
Media Converters	
Gigabit Media Converters	277
EL9100 Series	
Hardened 10/100/1000BASE-TX to 1000BASE-SX/LX/BX Media Converter	277
EL9000 Series	
Hardened 1000BASE-T to 1000BASE-SX/LX/BX Media Converter.....	281
EL9020 Series	
Hardened 10/100/1000BASE-TX to Gigabit SFP Media Converter.....	285
EL2321 Series	
Managed 10/100/1000BASE-TX to 100BASE/1000BASE-X Dual Rate Media Converter	289
EL2315 Series	
10/100/1000BASE-TX to 100/1000BASE-X Dual Rate SFP Media Converter	293
EL2326 Series	
OAM Managed 10/100/1000BASE-TX to 100/1000BASE-X Dual Rate Media Converter.....	296
EL2326L Series	
10/100/1000BASE-TX to 1000BASE-SX/LX/BX Media Converter.....	300
EL1216 Series	
10/100BASE-TX to 100BASE-FX Media Converter	303
EL2211 Series	
10/100/1000BASE-TX to 1000BASE-SX/LX/BX Media Converter.....	306
EM1100 / EM2100 Series	
10/100/1000BASE-TX to 1000BASE-FX Media Converter.....	310
EM1000 / EM2000 Series	
1000BASE-T to 1000BASE-SX/LX/BX Media Converter	313

EM1000S / EM2000S Series	
1000BASE-SX/LX to 1000BASE-LX/BX Media Converter	316
EM1020 Series	
1000BASE-T to Gigabit SFP Media Converter	319
Fast Ethernet Media Converters	322
EL900 Series	
Hardened 10/100BASE-TX to 100BASE-FX Media Converter	322
EL910 Series	
Hardened 10/100BASE-TX to 100BASE-SX/LX Media Converter	326
EL950 Series	
Hardened Managed 10/100BASE-TX to 100BASE-SX/LX Media Converter	330
EL1032T Series	
Industrial 10/100BASE-TX to 100BASE-FX Media Converter with PoE/PSE	334
EL1141 Series	
IEC61850/IEEE1613 Hardened 10/100BASE-TX to 100BASE-FX Media Converter	338
EX42011 Series	
Industrial 10/100BASE-TX to 100BASE-FX Media Converter	342
EL200 / EL210 Series	
10/100BASE-TX to 100BASE-BX WDM Media Converter	346
EL100 / EL110 Series	
10/100BASE-TX to 100BASE-FX Media Converter	349
EM120 Series	
100BASE-FX Multi-Mode/Single-Mode to 100BASE-FX Single-Mode Media Converter	352
EL50 Series	
Mini-Sized 10/100BASE-TX to 100BASE-FX Media Converter	355
EMC1600 Series	
16-Bay Media Converter and Ethernet Extender Chassis	358
Multiple Channel Media Converters	361
EMC400	
4-Bay Commercial Media Converter Chassis	361
EMC1200R Series	
12-Bay Media Converter System	364

Ethernet Extenders

Power over Link™ Ethernet Extenders 374

ED3638

Hardened 10/100BASE-TX PoL™/PoE Ethernet Extender over Coaxial Cable.....374

ED3538

Hardened 10/100BASE-TX PoL/PoE Ethernet Extender over Copper Wires 378

ED3238

10/100BASE-TX IEEE802.3af PoE Ethernet Extender over Coaxial Cable 382

Ethernet Extenders over Copper Pair 386

ED3541 Series

Hardened 10/100BASE-TX Ethernet Extender 386

ED3501 Series

Industrial 10/100BASE-TX Ethernet Extender 390

Ethernet Extenders over Copper Pair 394

ED3175 Series

Hardened Managed 8-port 10/100BASE-TX Switch with 2-port Copper Pair Extender 394

ED3146 Series

Hardened 4-Port 10/100BASE-TX IEEE802.3at PoE Ethernet Extender..... 399

ED3145 Series

Hardened 4-port 10/100BASE-TX Ethernet Extender..... 403

ED3171 Series

Managed Hardened 10/100BASE-TX Ethernet Extender 407

ED3141 Series

Hardened 10/100BASE-TX Ethernet Extender 411

ED3101 Series

Industrial 10/100BASE-TX Ethernet Extender 415

Ethernet Extenders over Coaxial Cable 419

ED3341 Series

Hardened 10/100BASE-TX Ethernet Extender over Coaxial Cable..... 419

ED3344 Series

Hardened 10/100/BASE-TX M12 Ethernet Extender over Coaxial Cable 423

ED3331 Series

Industrial 10/100BASE-TX Ethernet Extender over Coaxial Cable 427

Accessories

NIC Cards

439

GE3000 Series

PCI Express Gigabit Ethernet Adapter 439

GE3100 Series

PCI Express Gigabit Ethernet Adapter 442

EN301 Series

32bit PCI-Bus 100BASE-FX Ethernet Adapter 445

EN400 Series

PCI-Express 100BASE-FX/SFP Ethernet Adapter 448

Surge Protection Devices

451

PD1041

Hardened Surge Protection Device – RJ45 451

Industrial Power Supplies

454

DD-85-48

85W/1.78A 48VDC Industrial Power Supply 454

DD-85-55

85W/1.55A 55VDC Industrial Power Supply 456

DR-30-24

30W/1.5A 24VDC DIN-Rail Industrial Power Supply 458

DR-30-12

24W/1.5A DIN-Rail 24VDC Industrial Power Supply 460

DR-60-24

60W/2.5A DIN-Rail 24VDC Industrial Power Supply 462

DR-75-24

75W/3.2A DIN-Rail 24VDC Industrial Power Supply 464

DR-75-48

75W/1.6A DIN-Rail 48VDC Industrial Power Supply 466

DR-120-24

120W/5A DIN-Rail 24VDC Industrial Power Supply 468

DR-120-48

120W/2.5A DIN-Rail 48VDC Industrial Power Supply 470

SDR-120-48

120W/2.5A DIN-Rail 48VDC Industrial Power Supply 472

SDR-240-48	
240W/5A DIN-Rail 48VDC Industrial Power Supply	474
SDR-480-48	
480W/10A DIN-Rail 48VDC Industrial Power Supply	476
MDR-40-48	
40W/0.83A 48VDC Industrial Power Supply	478
Power Adaptors	480
GS-120A-48	
120W/2.5A 48VDC Power Adapter with Latched DC Jack in Plastic Housing	480
41-136042	
36W/3A 12VDC Hardened Power Adapter with Open Wire in Plastic Housing	481
41-136043	
36W/3A 12VDC Hardened Power Adapter with DC Plug in Aluminum Housing	482
41-136044	
36W/3A 12VDC Hardened Power Adapter with Latched DC Jack in Aluminum Housing	483
41-136046	
36W/3A 12VDC Hardened Power Adapter with Open Wire in Aluminum Housing	484
Mounting Kits	485
TransRack	
Mounting Kits	
SFP Modules	489
SFP Fiber Transceiver Series	

Table of Contents

Ethernet Switches	
Ethernet Switch Glossary	2
Ethernet Switch Connection Guide	9
Hardened Managed Ethernet Switches	21
ER59000 Series	
Hardened Managed 16-port 10/100BASE M12 (8 x PoE) with 2-port Gigabit LC Ethernet Switch.....	21
ER58000 Series	
Hardened Managed 8-port 10/100BASE M12 PoE with 2-port Gigabit M12 Ethernet Switch.....	26
EX78900 Series	
Hardened Managed 16-port (8 x PoE) Gigabit Ethernet Switch	31
EX78602 Series	
Hardened Managed 6-port 10/100BASE (4 x PoE + 2 x 60W PoE) and 2-port Gigabit Ethernet Switch.....	36
EX78000 Series	
Hardened Managed 10-port 10/100BASE (8 x PoE) and 2-port Gigabit Ethernet Switch	41
EX70900 Series	
Hardened Managed 8-port Gigabit Ethernet Switch.....	47
EX77000 Series	
Hardened Managed 24-port 10/100BASE and 4-port Gigabit Ethernet Switch with SFP options	52
EX87000 Series	
IEC61850-3/IEEE1613 Hardened Managed 24-port 10/100BASE and 4-port Gigabit Ethernet Switch with SFP options	58
EX89000 Series	
IEC61850-3/IEEE1613 Modulized Hardened Managed 24-port 10/100BASE and 4-port Gigabit Ethernet Switch with SFP options	64
EX75000 Series	
Hardened Managed 24-port 10/100BASE-TX + 4-port Gigabit Ethernet PoE Switch	70
EX76000 Series	
Hardened Managed 16-port 10/100BASE PoE with 2-port Gigabit combo Ethernet Switch.....	75
EX83000 Series	
IEC61850/IEEE1613 Managed Hardened 16-port 10/100BASE with 2-port Gigabit combo Ethernet Switch.....	81
EX73000 Series	
Hardened Managed 16-port 10/100BASE with 2-port Gigabit combo Ethernet Switch	87

Ethernet Switch Glossary

α -Ring (Alpha Ring)

STP and RSTP are traditional network redundancy technologies most commonly used; however, they cannot provide fast network recovery in minimizing packet loss caused by link failure on industrial networks. Due to this requirement, EtherWAN's α -Ring was developed in order to overcome this issue. EtherWAN's α -Ring provides a very fast network redundancy mechanism to recover from a network failure in a very short period of time. If there is a broken connection in the ring topology, the network will be recovered back to normal operation within 15ms.

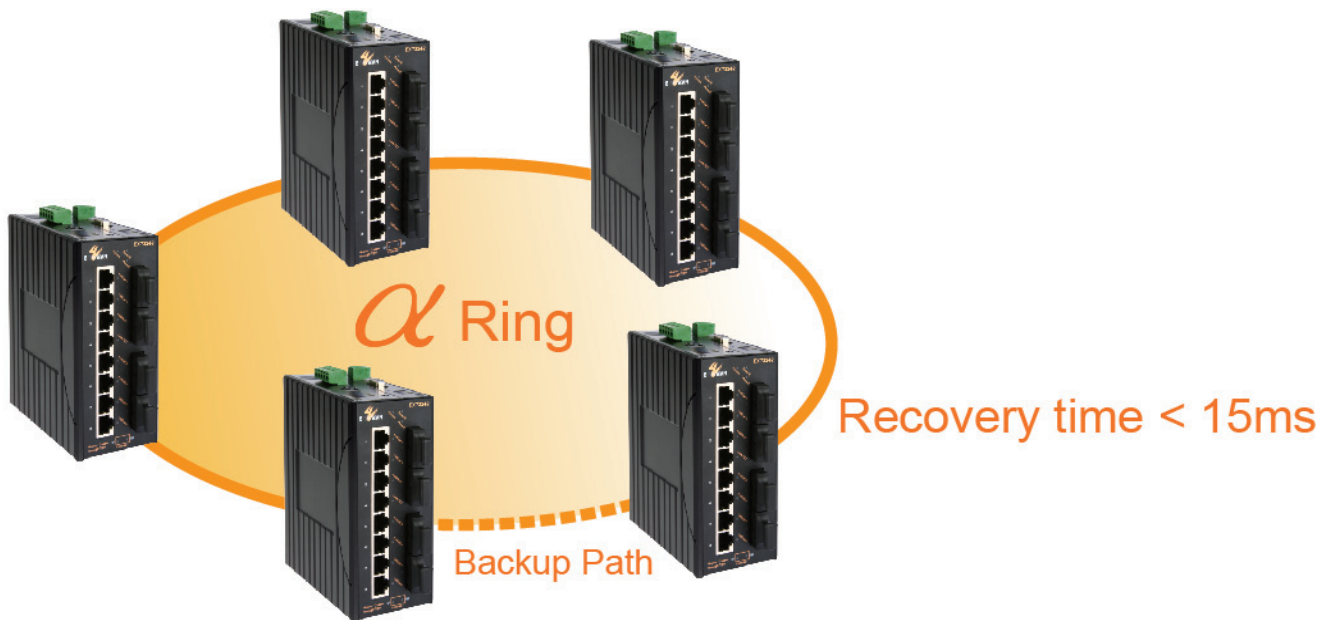

α -Chain (Alpha Chain)

Traditional Chain architecture does not support network redundancy mechanism. Based on network redundancy requirements, EtherWAN's α -Chain provides a network redundancy mechanism to recover from a network failure. It is suitable for different PLC and Unmanaged Switch and offers a variety of Chain redundancy

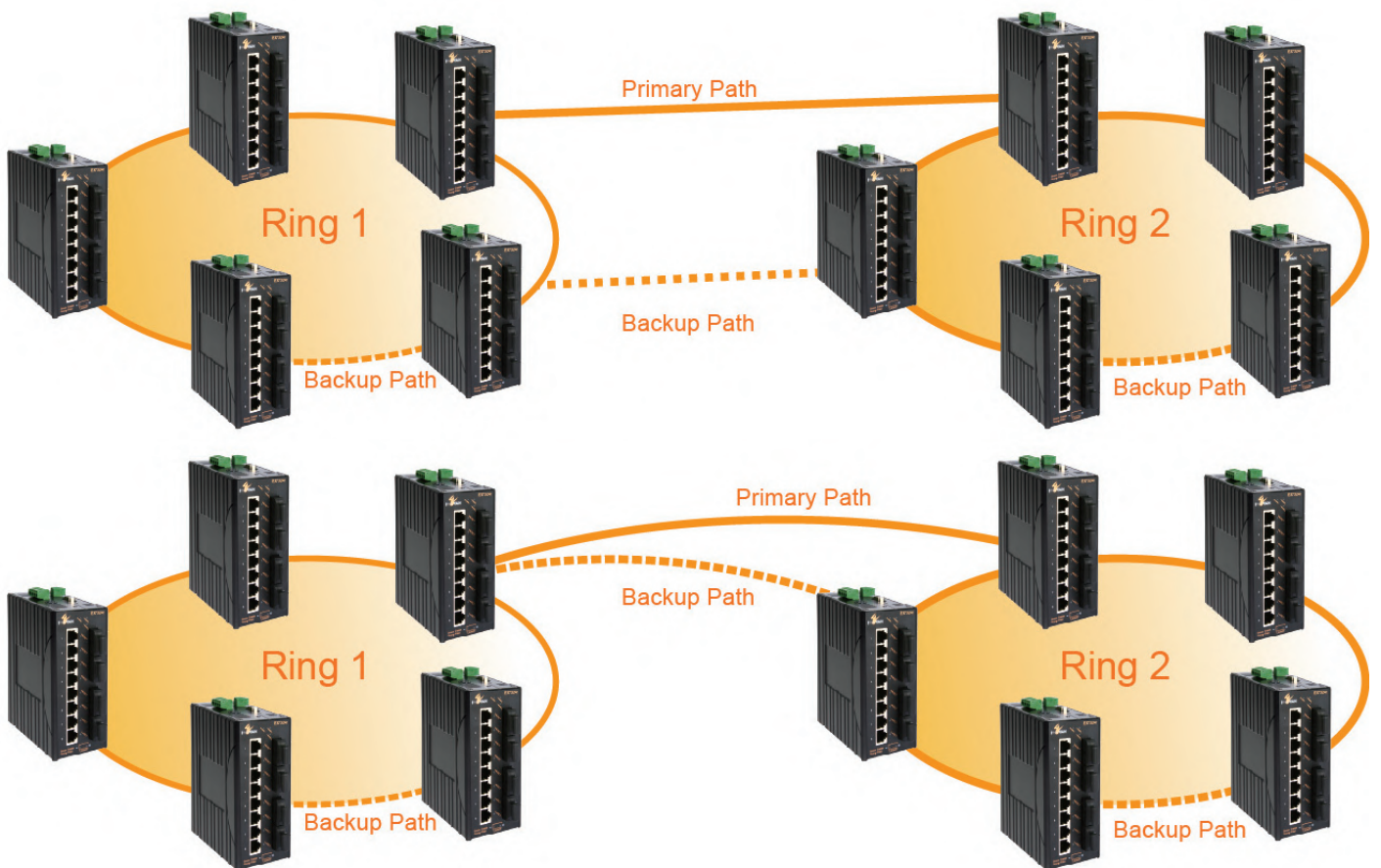
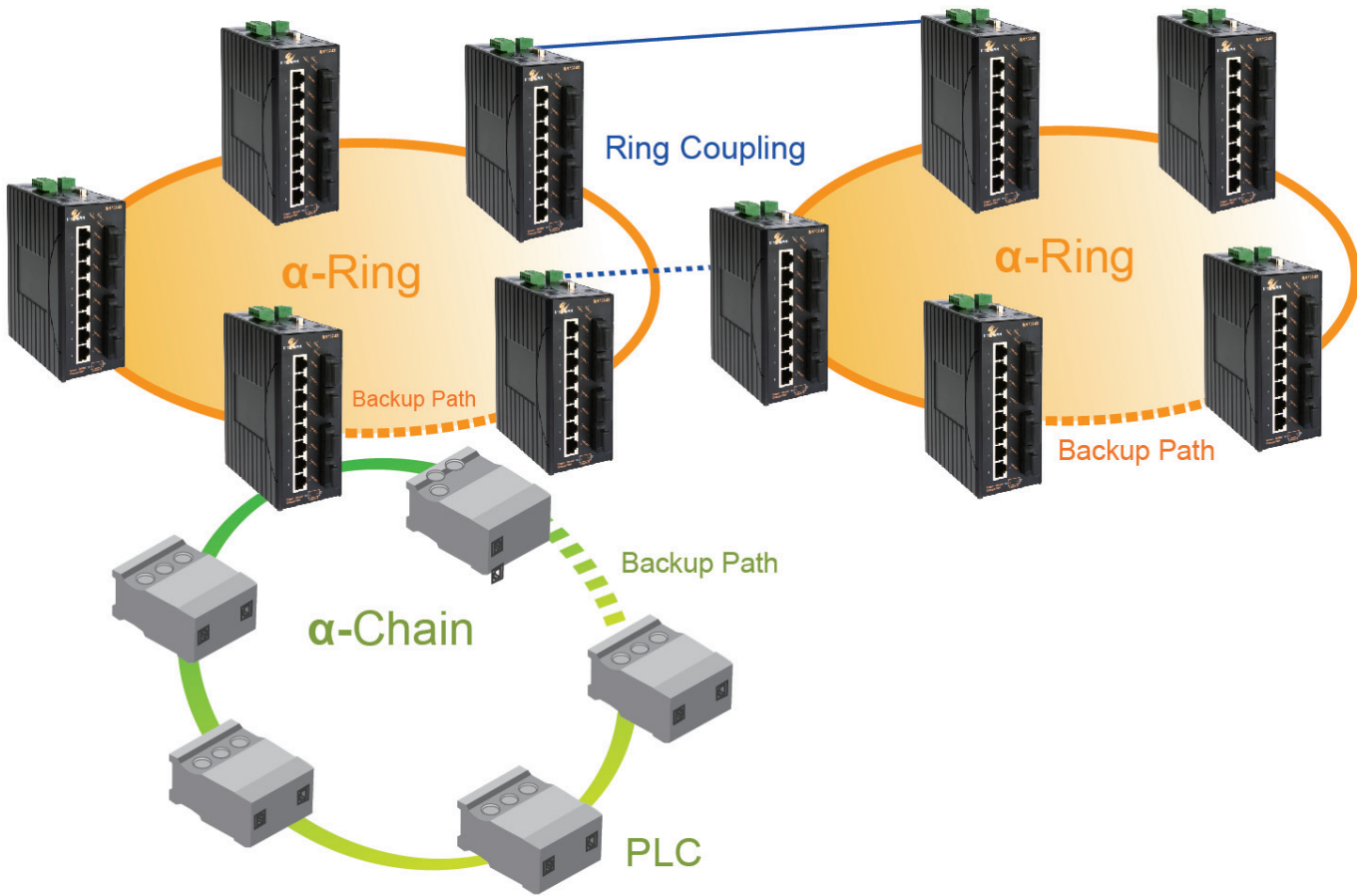

mode: a single switch, cross-switch, or cross-Ring design and planning.

Bandwidth Management

Rate control is used to meter and limit the data stream input or output rate to a port. The forwarding of broadcast traffic consumes the resources of a managed Ethernet switch, which can negatively impact the forwarding of other traffic. The rate control mechanism is used to protect regular traffic from broadcast or multicast traffic.

Command Line Interface (CLI)

The command line interface (CLI) is a network management application operated through an ASCII terminal that does not use a graphical user interface (GUI). Greater configuration flexibility can be achieved by directly entering commands into the terminal.

Dual Homing

Two rings may be connected together with redundant paths using α -Ring's dual homing feature. The back-up path between networks will activate within milliseconds once the primary connection between networks fails. Therefore, no matter what kind of network redundancy mechanism is incorporated, within each ring, whether it is RSTP or some other mechanism, network redundancy can be achieved between the two networks using α -Ring.

Internet Group Management Protocol (IGMP) Snooping

The purpose of IP multicast filtering is to optimize a switched network's performance, so that multicast packets will only be forwarded to those ports containing multicast group host members and routers instead of flooding to all of the ports in the subnet (VLAN).

Jumbo Frame

Jumbo Frames are large IP frames used in high-performance networks to increase performance over long distances. The term Jumbo Frame most often refers to Gigabit Ethernet frames that are higher than 9000 bytes, but they can refer to anything over the IP MTU (Maximum Transmission Unit) of 1500 bytes on an Ethernet frame.

Multiple Spanning Tree Protocol (MSTP, IEEE 802.1s)

MSTP was originally defined in IEEE 802.1s and was later merged into IEEE 802.1Q-2005. MSTP defines an extension to RSTP in order to further develop the usefulness of virtual LANs (VLANs). This per-VLAN Multiple Spanning Tree Protocol configures a separate spanning tree for each VLAN group and blocks all but one of the possible alternate paths within each spanning tree.

Network Time Protocol (NTP)

The Network Time Protocol (NTP) is a protocol for synchronizing all of the clocks in a network, using a set of distributed clients and servers.

Port Trunking and Link Aggregation Control Protocol (LACP, IEEE802.3ad)

Trunking is also called link aggregation, which serves as a shortcut to increase the bandwidth on a network. Trunking is a method of physically linking several ports together to act as a single port with higher bandwidth. This functionality allows bandwidth scaling. In addition, the trunking algorithm provides dynamic fail-over. Traffic automatically gets distributed to the remaining active ports if one of the ports fails, allowing for a seamless method of redundancy to occur over a trunk.

Port Security

EtherWAN's Managed Ethernet Switches provide filtering for source and destination MAC addresses. MAC address filtering allows a managed Ethernet switch to block an incoming packet to an interface when it sees a specified MAC address in either the source address or the destination address of the incoming packet. This filters unnecessary traffic, thereby providing intelligent control over traffic flows and broadcast traffic.

Port Mirroring

Port mirroring allows packets to be mirrored for network monitoring purposes and network debugging purposes. Traffic from any port can be mirrored to any other port using port mirroring.

PoE (Power over Ethernet)

Power over Ethernet or PoE technology describes a system of safely passing electrical power, along with data, through Ethernet cabling. The IEEE standard for PoE requires category 5 cable or higher for high power levels, but it can operate with category 3 cable for low power levels. Power is supplied in common mode over two or more of the differential pairs of wires found inside an Ethernet cable. It can come from a power supply within a PoE-enabled networking device, such as an Ethernet switch, or it can be injected into a cable that has a midspan power supply.

The original IEEE 802.3af-2003 PoE standard provides up to 15.4 W of DC power (a minimum of 44 VDC and 350 mA) to each device. However, only 12.95 W is certain to be available at the powered device, as some power will be dissipated in the cable. The updated IEEE 802.3at-2009 PoE standard, also known as PoE+ or PoE plus, provides up to 25.5 W of power. The 2009 standard prohibits a powered device from using all four pairs of wire for power; however, some vendors have announced products that claim to be compatible with the 802.3at standard and that can offer up to 51 W of power over a single cable, by utilizing all four pairs of wire in a category 5 cable.

Quality of Service (QoS, IEEE802.1p)

The Quality of Service (QoS) feature provides internal queues to support different classifications of traffic. High priority packet streams experience less delay inside managed Ethernet switches, which support lower latencies for certain delay-sensitive traffic. EtherWAN's Managed Ethernet Switch can classify packets according to the Port ID, MAC address, IEEE802.1p priority tag, DiffServ, and/or IP TOS.

Ring Coupling

Sometimes there might not only be one single ring in an industrial network. Industrial networks may be composed of numerous rings, as well as interconnected networks among these individual rings. The network among these rings can also provide network redundancy via the Coupling method. Thus, all the switches do not have to be confined and connected in one ring, since a single large ring that contains numerous switches can be broken into smaller, more manageable ring networks to ensure network efficiency and performance.

Rapid Spanning Tree Protocol (RSTP, IEEE802.1w)

RSTP provides significantly faster spanning tree convergence after a topology change, by introducing new convergence behaviors and bridge port roles. RSTP was designed to be backward-compatible with standard STP.

RMON

The switch supports the following RMON MIB groups defined in RFC 1757:

- a. The RMON Statistics Group, which maintains utilization and error statistics for the switch port being monitored.
- b. The RMON History Group, which gathers and stores periodic statistical samples from the previous statistics group.
- c. The RMON Alarm Group, which allows a network administrator to define alarm thresholds for any MIB variable. An alarm can be triggered when the value of a specific MIB variable exceeds or falls below a threshold.
- d. The RMON Event Group, which allows a network administrator to define actions based on alarms. SNMP Traps are generated when RMON Alarms are triggered.

Store-and-Forward

Store-and-forward switching is Cisco's primary LAN switching method. The store-and-forward method provides efficient and error-free transport instead of fast transport. In this mode, the complete data frame is received on the switch's buffer and a CRC is run. If the CRC passes, the switch looks up the destination hardware address in the MAC filter table, finds the correct outgoing interface, and sends the frame toward its destination.

Simple Network Management Protocol (SNMP)

Failure conditions and specific events discovered by EtherWAN's Managed Ethernet Switch series are reported to multiple user-defined destinations in the form of a SNMP trap.

IEEE802.3az Energy Efficient Ethernet (EEE)

Energy-Efficient Ethernet is a set of enhancements to the twisted-pair and backplane Ethernet family of computer networking standards that allow for less power consumption during periods of low data activity. The intention was to reduce power consumption while retaining full compatibility with existing equipment.

The Institute of Electrical and Electronics Engineers (IEEE), through the IEEE 802.3az task force developed the standard. Some companies introduced technology to reduce the power required for Ethernet before the standard was ratified, using the name Green Ethernet.

In 100 Mbit/s, 1 gigabit and 10 Gbit/s speed data links, energy is used to keep the physical layer transmitters on all the time. If they could be put into "sleep" mode when no data is being sent that energy could be saved. By sending a low-power-idle (LPI) indication signal for a specified time the transmit chips in the system can be turned off. LPI is sent periodically to refresh the sleep mode. When there is data to transmit a normal idle signal is sent to wake the transmit system up before data is due to be sent. The data link is considered to be always operational, as they receive signal circuit remains active even when the transmit path is in sleep mode.

Spanning Tree Protocol (STP, IEEE802.1D)

STP is a network protocol that ensures a loop-free topology for any bridged Ethernet local area network. The basic function of STP is to prevent bridge loops and the ensuing broadcast radiation. STP also allows a network design to include spare (redundant) links to provide automatic backup paths if an active link fails, without the danger of bridge loops or the need for manual enabling/disabling of the backup links.

UPoE (60W PoE/PSE)

UPoE is High Power PoE Specifications, integrated with 60W PoE/PSE switching support.

UPoE offers highly efficient four-pair operation, and full compliance with the IEEE 802.3at draft 4.1 high-power PoE specifications. It supports 2-event classification as specified in the latest IEEE 802.3at specifications.

Until today, the barrier to PoE adoption was its restriction to 15.4W and 30W, respectively, in 802.3af and 802.3at applications. UPoE will enable a host of new Ethernet applications to take full advantage of the well-known PoE benefits at 60W power levels.

Key Features

- * 802.3at draft 4.1 compliant, which delivers up to 60W on 4-pairs
- * 2-event classification
- * 10/100/100 Base-T support

Technology	Standard	Availability	PSE	PD	Current
PoE	IEEE802.3af	2003	15.4E	12.95W	350mA
PoE+ (AT)	IEEE802.3at	2009	30W	25.5W	600mA
UPoE/4 pairs	Proprietary	2012/2009	60W	51W	600mAx2

Virtual Local Area Network (VLAN, IEEE802.1Q)

The IEEE802.1Q standard establishes a method for inserting a virtual local area network identifier (VID) into the Ethernet frames. The sharing of VLANs between switches is achieved by inserting a tag with a VLAN identifier (VID) into each frame. VLANs can be extended across a large network by assigning the same VID to the VLANs on numerous switches. When using IEEE802.1Q, a VID must be assigned for each VLAN.

Web-based Management

The Managed Ethernet Switch also hosts a point-and-click Web-based interface that allows users to access the full configuration and functionality of the switch from an Internet browser.

Web-Smart Switch

The Web-Smart Switch allows end users to configure IP settings, port-based VLANs, QoS settings and to restore default settings, as well as to display status messages such as the PoE condition, link status and alarm conditions. All of the above can be done via a web browser, such as Internet Explorer, Firefox or Chrome.

Ethernet Switch Connection Guide



Model Name	ER59000	ER58000	EX77000	EX87000	EX89000
Interface					
Max. 10/100 BASE-TX	16 (M12)	8 (M12)	24	24	24
Max. 10/100/1000 BASE-T	2	2 (M12)	4	4	4
Max. 100 BASE-FX	-	-	24	24	18
Max. 100 BASE-SFP	-	-	24	24	4
Max. 1000 BASE - SX/LX/BX	2 (LC)	2 (LC)	4	4	4
Max. 1000 BASE - SFP	-	-	4	4	4
PoE Ports	8 (30W)	8 (30W)	-	-	-
PoE Power Budget	240W	120W	-	-	-
RS-232 Console Port	√	√	√	√	√
Alarm Contact	√	√	-	-	√
Performance					
MAC Address Table Size	8192	8192	8192	8192	8192
Packet Buffer Memory (bits)	2M	2M	3M	3M	3M
Mechanical					
Casing	metal	metal	metal	metal	metal
Installation*	W	P	R	R	R
Dimensions (WxDxH)	258x117x228	288x161.5x64	Single Power: 442x250x44 Dual Power: 442x375x44	Single Power: 442x284x44 Dual Power: 442x375x44	Single Power: 442x343x44
Power Input					
No. of Power Inputs	2	2	1 or 2	1 or 2	1
110 - 240VAC	-	-	√	√	√
Terminal Block	^{(55VDC) (M23) (PoE)} (12 - 48VDC) (M23) (nonPoE)	(24 - 48VDC) (M23)	±48VDC, 88 - 370VDC	±48VDC, 88 - 370VDC	±48VDC, 88 - 370VDC
DC Jack	-	-	-	-	-
AC to DC Adapter	-	-	-	-	-
Operating Temperature					
-10°C to 60°C	-	-	-	-	-
-40°C to 75°C	√	√	√	√	√
Network Redundancy					
α-Ring / α-Chain	√	√	√	√	√
STP / RSTP / MSTP	√	√	√	√	√
Network Management & Control					
	VLAN, QoS, IGMP, GMRP, LLDP, Bandwidth Rate Control, Port Trunking, Port Mirroring, Packet Filtering, DHCP Sever/Client, IEEE802.1x Security, SNMP (v1, v2c, v3), RMON, Web Management, Telnet Management, RS-232 Console Management				
Regulatory Approvals					
CE / FCC	√	√	√	√	√
UL508	-	-	-	-	-
ISA12.12.01 / UL1604	-	-	-	-	-
IEC61850-3 / IEEE1613	-	-	√	√	√
EN50121-4	-	-	-	√	√
EN50155	√	√	-	-	-
UL60950	-	-	-	-	-



Hardened Managed >>							
Model Name	EX75000	EX76000	EX78000	EX78602 ^{NEW}	EX78900 ^{NEW}	EX74000	EX83000
Interface							
Max. 10/100 BASE-TX	24	16	8	6	-	6	16
Max. 10/100/1000 BASE-T	2	2	2	2	12	2	2
Max. 100 BASE-FX	-	4	4	-	-	-	4
Max. 100 BASE-SFP	-	-	2	-	-	-	4
Max. 1000 BASE - SX/LX/BX	2	2	2	2	-	-	2
Max. 1000 BASE - SFP	4	-	2	2	4	2	2
PoE Ports	MAX. 12 (30W)+2G (30W) MAX. 24 (15.4W)+2G (30W)	16 (15.4W)	8 (15.4W) or 4 (30W) + 4 (15.4W)	4 (30W) + 2 (60W)	8 (60W)	4 (30W)	-
PoE Power Budget	420W	246.4W	180W	180W	240W	120W	-
RS-232 Console Port	√	√	√	√	√	√	√
Alarm Contact	√	√	√	√	√	-	√
Performance							
MAC Address Table Size	8192	8192	8192	8192	16K	8192	8192
Packet Buffer Memory (bits)	3M	2M	2M	2M	12M	2M	2M
Jumbo Frame (bytes)	2048	-	-	-	9216	-	-
Mechanical							
Casing	metal	metal	metal	metal	aluminum	metal	aluminum
Installation	R	R	D, P	D, P	D, P	P	D, P
Dimensions (WxDxH)	442x343x44	442x205x44	71.4x140x170	71.4x140x170	63x140x170	200x134x50	84x125x145
Power Input							
No. of Power Inputs	1	2	3	3	3	1	3
110 - 240VAC	-	-	-	-	-	-	-
Terminal Block	55VDC	48VDC	48VDC	55VDC	55VDC	48VDC (PoE)	12 - 48VDC
DC Jack	-	-	48VDC	55VDC	55VDC	-	12VDC
AC to DC Adapter	-	-	-	-	-	-	-
Operating Temperature							
-10°C to 60°C	-	-	-	-	-	-	-
-40°C to 75°C	√	√	√	√	√	-	√
Network Redundancy							
α-Ring / α-Chain	√	√	√	√	√	√	√
STP / RSTP / MSTP	√	√	√	√	√	√	√
Network Management & Control							
	VLAN, QoS, IGMP, GMRP, LLDP, Bandwidth Rate Control, Port Trunking, Port Mirroring, Packet Filtering, IEEE802.1x Security, SNMP (v1, v2c, v3), RMON, Web Management, Telnet Management, RS-232 Console Management						
Regulatory Approvals							
CE / FCC	√	√	√	√	√	√	√
UL508	-	√	√	√	-	-	-
ISA12.12.01 / UL1604	-	-	-	-	-	-	-
IEC61850-3 / IEEE1613	-	-	-	-	-	-	√
EN50121-4	-	-	-	-	-	-	-
UL60950	-	-	-	-	-	-	-

* D: DIN-Rail Mounting, P: Panel Mounting, R: Rack Mounting, W: Wall Mounting

ISA 12.12.01



EN50121-4

**Hardened Managed >>**

Model Name	EX73000	EX63000	EX72000	EX62000	EX71000	EX61000A	EX70900 <small>NEW</small>
Interface							
Max. 10/100 BASE-TX	16	16	14	14	8	8	-
Max. 10/100/1000 BASE-T	2	2	2	2	2	2	8
Max. 100 BASE-FX	4	4	2	2	4	4	-
Max. 100 BASE-SFP	-	-	-	-	4	4	-
Max. 1000 BASE - SX/LX/BX	2	2	2	2	2	2	2
Max. 1000 BASE - SFP	-	2	2	2	2	2	2
PoE Ports	-	-	-	-	-	-	-
PoE Power Budget	-	-	-	-	-	-	-
RS-232 Console Port	√	√	√	√	√	√	√
Alarm Contact	√	-	-	-	√	√	√
Performance							
MAC Address Table Size	8192	8192	8192	8192	8192	8192	4096
Packet Buffer Memory (bits)	2M	2M	2M	2M	2M	2M	1.536M
Jumbo Frame (bytes)	-	-	-	-	-	-	9720
Mechanical							
Casing	metal	aluminum	metal	metal	aluminum	metal	aluminum
Installation*	D, P	D, P	P, R	D, P, R	D, P, R	D, P, R	D, P
Dimensions (WxDxH)	65x125x45	59x125x45	235x125x50	235x125x50	60x125x145	54x125x145	66x125x145
Power Input							
No. of Power Inputs	3	3	2	2	3	3	3
110 - 240VAC	-	-	-	-	-	-	-
Terminal Block	12 - 48VDC	12 - 48VDC	12 - 48VDC	12 - 48VDC	12 - 48VDC	12 - 48VDC	12 - 48VDC
DC Jack	12VDC	12VDC	-	12VDC	12VDC	12VDC	12VDC
AC to DC Adapter	-	-	-	-	-	-	-
Operating Temperature							
-10°C to 60°C	-	-	-	√	-	√	-40°C to 75°C
-40°C to 75°C	√	√	√	-	√	-	-
Network Redundancy							
α-Ring / α-Chain	√	√	√	√	√	√	√
STP / RSTP / MSTP	√	√	√	√	√	√	√
Network Management & Control							
	VLAN, QoS, IGMP, GMRP, LLDP, Bandwidth Rate Control, Port Trunking, Port Mirroring, Packet Filtering, IEEE802.1x Security, SNMP (v1, v2c, v3), RMON, Web Management, Telnet Management, RS-232 Console Management						
Regulatory Approvals							
CE / FCC	√	√	√	√	√	√	√
UL508	√	-	√	-	√	√	-
ISA12.12.01 / UL1604	√	-	-	-	-	-	-
IEC61850-3 / IEEE1613	-	-	-	-	-	-	-
EN50121-4	-	-	-	-	√	-	-
UL60950	-	-	-	-	-	-	-

* D: DIN-Rail Mounting, P: Panel Mounting, R: Rack Mounting, W: Wall Mounting



Hardened Unmanaged >>						
Model Name	EX39924 ^{NEW}	EX95000	EX33000	EX47000	EX94000	EX35000
Interface						
Max. 10/100 BASE-TX	-	16	16	8	8	-
Max. 10/100/1000 BASE-T	24	-	-	-	-	8
Max. 100 BASE-FX	-	2	2	2	4	-
Max. 100 BASE-SFP	-	-	-	-	-	-
Max. 1000 BASE - SX/LX/BX	-	-	-	-	-	2
Max. 1000 BASE - SFP	4 (Combo) / 16 (Combo)	-	-	-	-	2
PoE Ports	-	-	-	-	-	-
PoE Power Budget	-	-	-	-	-	-
RS-232 Console Port	-	-	-	-	-	-
Alarm Contact	-	✓	✓	✓	✓	✓
Performance						
MAC Address Table Size	8192	4096	4096	2048	2048	8192
Packet Buffer Memory (bits)	4.096M	1.625M	1.625M	448K	768K	1.125M
Jumbo Frame (bytes)	16379	-	-	-	-	-
Mechanical						
Casing	metal	aluminum	aluminum	aluminum	aluminum	aluminum
Installation*	R	D, P, R	D, P, R	D, P,	D, P	D, P
Dimensions (WxDxH)	208.8x440x44	75.5x110x135	69.5x110x135	60x125x145	50x110x145	68x110x135
Power Input						
No. of Power Inputs	1	3	3	3	3	3
100 - 240VAC	✓	-	-	-	-	-
Terminal Block	-	12 - 48VDC	12 - 48VDC	12 - 48VDC	12 - 48VDC	12 - 32VDC
DC Jack	-	12VDC	12VDC	12VDC	12VDC	12VDC
AC to DC Adapter	-	-	-	-	-	-
Operating Temperature						
-10°C to 60°C	✓	-	✓	-	-	-20°C to 60°C
-40°C to 75°C	-	✓	-	✓	✓	-
Network Redundancy						
α-Ring / α-Chain	-	-	-	-	-	-
STP / RSTP / MSTP	-	-	-	-	-	-
Network Management & Control						
-						
Regulatory Approvals						
CE / FCC	✓	✓	✓	✓	✓	✓
UL508	-	✓	✓	-	✓	✓
ISA12.12.01 / UL1604	-	-	-	-	✓	-
IEC61850-3 / IEEE1613	-	-	-	✓	-	-
EN50121-4	-	-	-	✓	-	-
UL60950	-	-	-	-	-	-

* D: DIN-Rail Mounting, P: Panel Mounting, R: Rack Mounting, W: Wall Mounting



Hardened Unmanaged >>

Model Name	EX49000	EX49000A	EX46100	EX48000	EX38000
Interface					
Max. 10/100 BASE-TX	16	16	8	5	5
Max. 10/100/1000 BASE-T	2	2	-	-	-
Max. 100 BASE-FX	-	-	2	1	1
Max. 100 BASE-SFP	-	-	-	-	-
Max. 1000 BASE - SX/LX/BX	2	2	-	-	-
Max. 1000 BASE - SFP	2	2	-	-	-
PoE Ports	16 (30W)	16 (30W)	4 (30W)	4 (30W)	4 (30W)
PoE Power Budget	480W	480W	120W	120W	120W
RS-232 Console Port	-	-	-	-	-
Alarm Contact	√	√	√	√	√
Performance					
MAC Address Table Size	4096	4096	1024	1024	1024
Packet Buffer Memory (bits)	2.25M	2.25M	1M	512K	512K
Mechanical					
Casing	metal	metal	aluminum	metal	metal
Installation*	R	R	D, P, R	Desktop, W	Desktop, W
Dimensions (WxDxH)	442x205x44.2	442x205x44.2	68x135x110	200x134.3x35	200x134.3x35
Power Input					
No. of Power Inputs	2	2	3	3	3
110 - 240VAC	-	-	-	-	-
Terminal Block	47 - 57VDC	47 - 57VDC	47 - 57VDC	47 - 57VDC	47 - 57VDC
DC Jack	-	-	47 - 57VDC	47 - 57VDC	47 - 57VDC
AC to DC Adapter	-	-	-	-	-
Operating Temperature					
-10°C to 60°C	-	-	-	-	√
-40°C to 75°C	√	√	√	√	-
Network Redundancy					
α-Ring / α-Chain	-	-	-	-	-
STP / RSTP / MSTP	-	-	-	-	-
Network Management & Control					
	System, IP Configuration, VLAN,QoS, Web Management	-		System, IP Configuration, VLAN,QoS, Web Management	
Regulatory Approvals					
CE / FCC	√	√	√	√	√
UL508	-	-	-	-	-
ISA12.12.01 / UL1604	-	-	-	-	-
IEC61850-3 / IEEE1613	-	-	-	-	-
EN50121-4	-	-	-	-	-
UL60950	-	-	-	-	-

* D: DIN-Rail Mounting, P: Panel Mounting, R: Rack Mounting, W: Wall Mounting



Hardened Unmanaged >>

Model Name	EX48000A	EX45000	EX34000
Interface			
Max. 10/100 BASE-TX	5	8	8
Max. 10/100/1000 BASE-T	-	-	-
Max. 100 BASE-FX	1	2	2
Max. 100 BASE-SFP	-	-	-
Max. 1000 BASE - SX/LX/BX	-	-	-
Max. 1000 BASE - SFP	-	-	-
PoE Ports	4 (15.4W)	4 (15.4W)	4 (15.4W)
PoE Power Budget	61.6W	61.6W	61.6W
RS-232 Console Port	-	-	-
Alarm Contact	√	√	√
Performance			
MAC Address Table Size	1024	1024	1024
Packet Buffer Memory (bits)	512K	1M	1M
Mechanical			
Casing	metal	aluminum	aluminum
Installation*	Desktop, W	D, P, R	D, P, R
Dimensions (WxDxH)	200x134.3x35	68x110x135	62x110x135
Power Input			
No. of Power Inputs	3	2	3
110 - 240VAC	-	-	-
Terminal Block	47 - 57VDC	47 - 57VDC	47 - 57VDC
DC Jack	47 - 57VDC	47 - 57VDC	47 - 57VDC
AC to DC Adapter	-	-	-
Operating Temperature			
-10°C to 60°C	-	-	√
-40°C to 75°C	√	√	-
Network Redundancy			
α-Ring / α-Chain	-	-	-
STP / RSTP / MSTP	-	-	-
Network Management & Control			
	-	-	-
Regulatory Approvals			
CE / FCC	√	√	√
UL508	-	-	-
ISA12.12.01 / UL1604	-	-	-
IEC61850-3 / IEC61850-1	-	-	-
EN50121-4	-	-	-
UL60950	-	-	-

* D: DIN-Rail Mounting, P: Panel Mounting, R: Rack Mounting, W: Wall Mounting



Hardened Unmanaged >>

Model Name	EX43000	EX45900 ^{NEW}	EX42900 ^{NEW}	EX32900 ^{NEW}	EX42200	EX42000
Interface						
Max. 10/100 BASE-TX	8	-	-	-	5	5
Max. 10/100/1000 BASE-T	-	5	5 / 8	5 / 8	-	-
Max. 100 BASE-FX	4	-	-	-	1	1
Max. 100 BASE-SFP	-	-	-	-	-	-
Max. 1000 BASE - SX/LX/BX	-	1	1	1	-	-
Max. 1000 BASE - SFP	-	1	-	-	-	-
PoE Ports	-	4 (30W)	-	-	4 (30W)	-
PoE Power Budget	-	120W	-	-	120W	-
RS-232 Console Port	-	-	-	-	-	-
Alarm Contact	√	√	- / √	- / √	√	√
Performance						
MAC Address Table Size	2048	8192	8192 / 4096	8192 / 4096	2048	2048
Packet Buffer Memory (bits)	768K	1M	1M / 192K	1M / 192K	448K	384K
Jumbo Frame (bytes)	-	10K	10K / 9720	10K / 9720	-	-
Mechanical						
Casing	aluminum	metal	metal	plastic	aluminum	plastic
Installation*	D	D	D	D	D	D
Dimensions (WxDxH)	50x125x135	30x100x149	30x70x110 30x100x149	26x70x110 30x86x149	61x73x110	26x70x110
Power Input						
No. of Power Inputs	2	2	1 / 2	1 / 2	2	1
100 - 240VAC	-	-	-	-	-	-
Terminal Block	12 - 30VDC	24 / 48VDC	12 - 48VDC	12 - 48VDC	18 - 57VDC	12 - 48VDC
DC Jack	12VDC	-	-	-	-	-
AC to DC Adapter	-	-	-	-	-	-
Operating Temperature						
-10°C to 60°C	-20°C to 60°C	-	-	√	-	√
-40°C to 75°C	-	√	√	-	√	-
Network Redundancy						
α-Ring / α-Chain	-	-	-	-	-	-
STP / RSTP / MSTP	-	-	-	-	-	-
Network Management & Control						
-						
Regulatory Approvals						
CE / FCC	√	√	√	√	√	√
UL508	-	-	-	-	-	-
ISA12.12.01 / UL1604	-	-	-	-	-	-
IEC61850-3 / IEC61850-1	-	-	-	-	-	-
EN50121-4	-	-	-	-	-	-
UL60950	√	-	-	-	-	√

* D: DIN-Rail Mounting, P: Panel Mounting, R: Rack Mounting, W: Wall Mounting



Non-Hardened Managed >>

Model Name	EX27000	EX29000	EX25611	EX26262	EX26182
Interface					
Max. 10/100 BASE-TX	24	24	-	-	-
Max. 10/100/1000 BASE-T	4	4	24	24	18
Max. 100 BASE-FX	24	18	-	-	-
Max. 100 BASE-SFP	24	-	-	-	-
Max. 1000 BASE - SX/LX/BX	4	4	-	-	-
Max. 1000 BASE - SFP	4	4	8	2	2
PoE Ports	-	-	-	24 (30W)	18 (30W)
PoE Power Budget	-	-	-	190W	190W
RS-232 Console Port	√	√	√	-	-
Alarm Contact	-	√	-	-	-
Performance					
MAC Address Table Size	8192	8192	32K	8192	8192
Packet Buffer Memory (bits)	3M	3M	256M	64M	64M
Mechanical					
Casing	metal	metal	metal	metal	metal
Installation*	R	R	R	R	R
Dimensions (WxDxH)	Single Power: 442x343x44 Dual Power: 442x375x44	Single Power: 442x343x44	442x300x44	440x350x44	440x350x44
Power Input					
No. of Power Inputs	1 or 2	1	1	1	1
100 - 240VAC	√	√	√	√	√
Terminal Block	±48VDC, 88 - 370VDC	±48VDC, 88 - 370VDC	-	-	-
DC Jack	-	-	-	-	-
AC to DC Adapter	-	-	-	-	-
Operating Temperature					
0°C to 45°C	-	-	0°C to 40°C	√	√
-10°C to 60°C	√	√	-	-	-
-40°C to 75°C	-	-	-	-	-
Network Redundancy					
α-Ring / α-Chain	√	√	-	-	-
STP / RSTP / MSTP	√	√	√	√	√
Network Management & Control					
	VLAN, QoS, IGMP, GMRP, Bandwidth Rate Control, Port Trunking, Port Mirroring, Packet Filtering, IEEE802.1x Security, SNMP (v1, v2c, v3), RMON, Web Management, Telnet Management, RS232 Console Management (except EX26262 and EX26182)				
Regulatory Approvals					
CE / FCC	√	√	√	√	√
UL508	-	-	-	-	-
ISA12.12.01 / UL1604	-	-	-	-	-
IEC61850-3 / IEEE1613	√	-	-	-	-
EN50121-4	√	-	-	-	-
UL60950	-	-	-	√	√

* D: DIN-Rail Mounting, P: Panel Mounting, R: Rack Mounting, W: Wall Mounting



Non-Hardened Unmanaged >>

Model Name	EX17242	EX17162	EX17162A	EX17016	EX17016A
Interface					
Max. 10/100 BASE-TX	24	16	16	16	16
Max. 10/100/1000 BASE-T	2	2	2	-	-
Max. 100 BASE-FX	-	-	-	-	-
Max. 100 BASE-SFP	-	-	-	-	-
Max. 1000 BASE - SX/LX/BX	-	-	-	-	-
Max. 1000 BASE - SFP	2 (Combo)	2 (Combo)	2 (Combo)	-	-
PoE Ports	24(15.4W)	16 (15.4W)	16 (15.4W)	16 (15.4W)	16 (15.4W)
PoE Power Budget	369.6W	246.4W	246.4W	246.4W	246.4W
RS-232 Console Port	-	-	-	-	-
Alarm Contact	-	-	-	-	-
Performance					
MAC Address Table Size	4096	4096	4096	4096	4096
Packet Buffer Memory (bits)	2.75M	2.75M	2.75M	1.5M	1.5M
Mechanical					
Casing	metal	metal	metal	metal	metal
Installation*	R	R	R	R	R
Dimensions (WxDxH)	440x330x44	440x330x44	440x330x44	440x220x44	440x220x44
Power Input					
No. of Power Inputs	1	1	1	1	1
110 - 240VAC	√	√	√	√	√
Terminal Block	-	-	-	-	-
DC Jack	-	-	-	-	-
AC to DC Adapter	-	-	-	-	-
Operating Temperature					
0°C to 45°C	√	√	√	√	√
-10°C to 60°C	-	-	-	-	-
-40°C to 75°C	-	-	-	-	-
Network Redundancy					
α-Ring / α-Chain	-	-	-	-	-
STP / RSTP / MSTP	-	-	-	-	-
Network Management & Control					
	System, IP Configuration, VLAN, QoS, Web Management		-	System, IP Configuration, VLAN, QoS, Web Management	
Regulatory Approvals					
CE / FCC	√	√	√	√	√
UL508	-	-	-	-	-
ISA12.12.01 / UL1604	-	-	-	-	-
IEC61850-3 / IEEE1613	-	-	-	-	-
EN50121-4	-	-	-	-	-
UL60950	-	-	-	√	√

* D: DIN-Rail Mounting, P: Panel Mounting, R: Rack Mounting, W: Wall Mounting



Non-Hardened Unmanaged >>							
Model Name	EX17908	EX17082	EX17008	EX17908A	EX17082A	EX17008A	EX17044A
Interface							
Max. 10/100 BASE-TX	-	8	8	-	8	8	8
Max. 10/100/1000 BASE-T	8	2	-	8	2	-	-
Max. 100 BASE-FX	-	-	-	-	-	-	-
Max. 100 BASE-SFP	-	-	-	-	-	-	-
Max. 1000 BASE - SX/LX/BX	-	-	-	-	-	-	-
Max. 1000 BASE - SFP	-	2 (Combo)	-	-	-	-	-
PoE Ports	8 (30W)	8 (30W)	8 (15.4W)	8 (30W)	8 (30W)	8 (15.4W)	4 (15.4W)
PoE Power Budget	240W	240W	123.2W	240W	240W	123.2W	59W
RS-232 Console Port	-	-	-	-	-	-	-
Alarm Contact	-	-	-	-	-	-	-
Performance							
MAC Address Table Size	8192	4096	1024	8192	4096	1024	1024
Packet Buffer Memory (bits)	1M	2.75M	512K	1M	2.75M	512K	512K
Mechanical							
Casing	metal	metal	metal	metal	metal	metal	metal
Installation*	Desktop	R	Desktop	Desktop	R	Desktop	Desktop
Dimensions (WxDxH)	266x160x44	440x220x44	266x160x44	266x160x44	440x220x44	266x160x44	266x160x44
Power Input							
No. of Power Inputs	1	1	1	1	1	1	1
110 - 240VAC	√	√	√	√	√	√	√
Terminal Block	-	-	-	-	-	-	-
DC Jack	-	-	-	-	-	-	-
AC to DC Adapter	-	-	-	-	-	-	-
Operating Temperature							
0°C to 45°C	(0°C to 40°C)	√	√	(0°C to 40°C)	√	√	√
-10°C to 60°C	-	-	-	-	-	-	-
-40°C to 75°C	-	-	-	-	-	-	-
Network Redundancy							
α-Ring / α-Chain	-	-	-	-	-	-	-
STP / RSTP / MSTP	-	-	-	-	-	-	-
Network Management & Control							
	System, IP Configuration, VLAN, QoS, Web Management						
Regulatory Approvals							
CE / FCC	√	√	√	√	√	√	√
UL508	-	-	-	-	-	-	-
ISA12.12.01 / UL1604	-	-	-	-	-	-	-
IEC61850-3 / IEEE1613	-	-	-	-	-	-	-
EN50121-4	-	-	-	-	-	-	-
UL60950	-	-	√	-	-	√	√

* D: DIN-Rail Mounting, P: Panel Mounting, R: Rack Mounting, W: Wall Mounting



Non-Hardened Unmanaged >>

Model Name	EX1608SF	EX16900 <small>NEW</small>	EX1608B/BF1
Interface			
Max. 10/100 BASE-TX	6	-	8
Max. 10/100/1000 BASE-T	-	5 / 8	-
Max. 100 BASE-FX	8	-	1
Max. 100 BASE-SFP	-	-	-
Max. 1000 BASE - SX/LX/BX	-	1	-
Max. 1000 BASE - SFP	-	1	-
PoE Ports	-	-	-
PoE Power Budget	-	-	-
RS-232 Console Port	-	-	-
Alarm Contact	-	-	-
Performance			
MAC Address Table Size	2048	2048 / 4096	2048
Packet Buffer Memory (bits)	768K	1M / 192K	1M
Jumbo Frame (bytes)	-	9K / 9720	-
Mechanical			
Casing	metal	metal	metal
Installation*	R	Desktop	R, W
Dimensions (WxDxH)	443.6x203.2x44	160x80.5x28	252x134.3x35
Power Input			
No. of Power Inputs	1	1	1
110 - 240VAC	√	-	√
Terminal Block	-	-	-
DC Jack	-	5VDC	-
AC to DC Adapter	-	√	-
Operating Temperature			
0°C to 45°C	√	√	√
-10°C to 60°C	-	-	-
-40°C to 75°C	-	-	-
Network Redundancy			
α-Ring / α-Chain	-	-	-
STP / RSTP / MSTP	-	-	-
Network Management & Control			
-			
Regulatory Approvals			
CE / FCC	√	√	√
UL508	-	-	-
ISA12.12.01 / UL1604	-	-	-
IEC61850-3 / IEEE1613	-	-	-
EN50121-4	-	-	-
UL60950	-	√	-

* D: DIN-Rail Mounting, P: Panel Mounting, R: Rack Mounting, W: Wall Mounting



Non-Hardened Unmanaged >>

Model Name	EX1605PB/PBF1	EX1608PB/PBF1	EX1616W
Interface			
Max. 10/100 BASE-TX	5	8	16
Max. 10/100/1000 BASE-T	-	-	-
Max. 100 BASE-FX	1	1	1
Max. 100 BASE-SFP	-	-	-
Max. 1000 BASE - SX/LX/BX	-	-	-
Max. 1000 BASE - SFP	-	-	-
PoE Ports	-	-	-
PoE Power Budget	-	-	-
RS-232 Console Port	-	-	-
Alarm Contact	-	-	-
Performance			
MAC Address Table Size	2048	2048	4096
Packet Buffer Memory (bits)	1M	1M	1.5M
Mechanical			
Casing	metal	metal	metal
Installation*	W	W	R
Dimensions (WxDxH)	160x80.5x28	160x80.5x28	440x207x44
Power Input			
No. of Power Inputs	1	1	1
110 - 240VAC	-	-	√
Terminal Block	-	-	-
DC Jack	12VDC	12VDC	-
AC to DC Adapter	√	√	-
Operating Temperature			
0°C to 45°C	√	√	√
-40°C to 75°C	-	-	-
Network Redundancy			
α-Ring / α-Chain	-	-	-
STP / RSTP / MSTP	-	-	-
Network Management & Control			
	-	-	System, IP Configuration, VLAN, QoS, Web Management
Regulatory Approvals			
CE / FCC	√	√	√
UL508	-	-	-
ISA12.12.01 / UL1604	-	-	-
IEC61850-3 / IEEE1613	-	-	-
EN50121-4	-	-	-
UL60950	-	-	-

* D: DIN-Rail Mounting, P: Panel Mounting, R: Rack Mounting, W: Wall Mounting

ER59000 Series

Hardened Managed 16-port 10/100BASE M12 (8 x PoE)
with 2-port Gigabit LC Ethernet Switch



Overview

EtherWAN's ER59000 Series provides a hardened 18-port switching platform supporting IEEE802.3at Power over Ethernet, high performance switching with robust management features required for railway transportation application.

The ER59000 Series is equipped with 16x 10/100BASE-TX (8x PoE) with M12 connector, in combination with two Gigabit LC Fiber ports options. The rugged, weatherproof IP67 rated switch is ideal for use in extreme environments. Compliant with EN50155 standard, the ER59000 Series is designed for rolling stock applications.

The IEEE802.3at PoE ports provide up to 30W/port with a total power budget of 240W, making the switch truly versatile for connecting with PoE Powered Devices (PD) with different bandwidth and power consumption requirements such as; outdoor PTZ dome cameras, wireless access points, and way-side communication devices.

Panel mountable, the ER59000 Series is equipped with EtherWAN's Alpha-Ring self-healing ring technology providing less than 15ms fault recovery time. Users are able to access management features such as port security, IGMP snooping, port-based VLAN, GARP protocols, link aggregation, via web browser, telnet, SSH, SNMP, RMON, TFTP, and console interfaces. With the hardened specifications, the ER59000 Series is designed to operate at -40°C to 75°C with IP67 protection in harsh environments, where dust, water immersion, high ESD, shock, and vibration may be present.

EtherWAN — "When Connectivity is Crucial."

Spotlight

• Railway Oriented

- Compliant with EN50155/EN50121-3-2/EN50121-4 railway applications

• M12 Connector

- Built-in 16-port 10/100BASE M12 plus 2-port Gigabit Copper/LC
- 8-port PoE function with IEEE802.3at up to 30W per port

• IP67 Rated Fully Managed Ethernet Switch

- IP67 grade protection and rugged enclosure design

Software Features

Management

- Interface
 - CLI, Telnet and Web Browser
 - SNMP v1/v2c/v3
- Firmware and configuration upgrade and backup via TFTP
- Supports DHCP Server/Client
- RMON (Remote monitoring): group 1, 2, 3, 9
- Port mirroring: TX/RX and both
- NTP (Network Time Protocol) time synchronization
- IEEE802.1ab LLDP (Link Layer Discovery Protocol)

Security

- MAC address filtering
- Enable/disable port
- Storm control (broadcast and multicast types)
- IEEE802.1x LAN access control
- Remote authentication through RADIUS
- SSH for CLI and Telnet security
- SSL for web security
- Multi-level user account/password against unauthorized configuration

Quality of Service (QoS)

- Priority Queues: 4 queues per port
- Traffic classification based on IEEE802.1p CoS, DSCP, WRR (Weighted round robin) and strict mode
- Rate Limiting (Ingress/Egress)

Layer 2 Features

- Auto-negotiation for port speed and duplex mode
 - Flow Control
 - IEEE802.3x full duplex mode
 - Back-Pressure half duplex mode
- Redundant Protocols
 - IEEE802.1D Spanning Tree Protocol (STP)
 - IEEE802.1w Rapid Spanning Tree Protocol (RSTP)
 - IEEE802.1s Multiple Spanning Tree Protocol (MSTP)
 - EtherWAN's Alpha-Ring network fault recovery (<15ms)
- VLANs
 - Port-based VLANs
 - IEEE802.1Q Tag VLANs (128 groups, 4096 VID)
 - GVRP (GARP VLAN Registration Protocol)
 - GMRP (GARP Multicast Registration Protocol)
- Link Aggregation
 - Static trunk (2 groups, support MAC base)
 - IEEE802.3ad Link Aggregation Control Protocol
- IGMP Snooping
 - IGMP snooping v1/v2/v3

Performance

- Switching Capability: 7.2Gbps
- Packet Buffer Size: 2M bits
- MAC Address Table: 8K

Hardware Specifications

Technology

Standards

- IEEE802.3 10BASE-T
- IEEE802.3u 100BASE-TX/100BASE-FX
- IEEE802.3ab 1000BASE-T
- IEEE802.3z 1000BASE-SX/1000BASE-LX
- IEEE802.3x Full duplex and flow control
- IEEE802.1p QoS
- IEEE802.1Q Tag VLANs
- IEEE802.1w RSTP
- IEEE802.1x Port-based Network Access Control
- IEEE802.1s MSTP
- IEEE802.3ad LACP
- IEEE802.3af/at Power over Ethernet (PoE)

Forward and Filtering Rate

- 14,880pps for 10Mbps
- 148,810pps for 100Mbps
- 1,488,100pps for 1000Mbps

Packet Buffer Memory

- 2M bits

Processing Type

- Store-and-Forward
- Half-duplex back-pressure and IEEE802.3x full-duplex flow control

Address Table Size

- 8192 MAC addresses

Power

Input

- Redundant power inputs:
 - M23: 12 - 48VDC (non-PoE model)
 - M23: 55 (52 to 57) VDC

Power Consumption

- Device: Max. 11W (without PoE)
- PoE power budget (depends on power input): 240W Max

PoE Power Output

- Port 1 to 8: IEEE802.3at, up to 30W/port, 47 - 57VDC

Protection

- Overload current protection
- Reverse polarity protection

Mechanical

Casing

- Die-cast aluminum
- IP67

Dimensions

- 258mm (W)x 228mm(D)x 83.5mm(H)
(10.1"(W) x 8.9"(D) x 3.2"(H))

Weight

- 2.3Kg (5.07lbs)

Installation

- Panel mounting

Interface

Ethernet Port

- 10/100BASE-M12 D-Code 4-Pin Female: 16 ports
- Gigabit-TX/LC: 2 ports

Console Port

- Port: M12 RS232 Console

LED Indicators

- Per Unit: Power 1 (Green)
Power 2 (Green)
- Per Port: Link/Activity (Green)
- Per PoE Port (Port 1 to 8 for PoE model only): PoE (Green)

Alarm Contact

- One relay M12 A-Code 4-Pin Female output with current 1A @ 250 VAC

Environment

Operating Temperature

- -40°C to 75°C (-40°F to 167°F)
Tested @ -40°C to 85°C (-40°F to 185°F)

Storage Temperature

- -45°C to 85°C (-49°F to 185°F)

Ambient Relative Humidity

- 5% to 95% (non-condensing)

Regulatory Approvals

ISO

- Manufactured in an ISO9001 facility

EMI

FCC Part 15B, Class A

EN61000-6-4

EN55022

EN55011 (for EN50155)

EMS

EN61000-6-2

- EN61000-4-2 (ESD Standards)
- EN61000-4-3 (RFI Standards)
- EN61000-4-4 (Burst Standards)
- EN61000-4-5 (Surge Standards)
- EN61000-4-6 (Induced RFI Standards)
- EN61000-4-8 (Magnetic Field Standards)
- EN61000-4-9 (Pulsed magnetic field)

Environmental Test Compliance

IEC61373 (Vibration) for EN50155

IEC61373 (Shock) for EN50155

IEC600680-2-32 Ed (Free fall)

Industrial Compliance

EN50155

EN50121-3-2

EN50121-4

Application Diagram

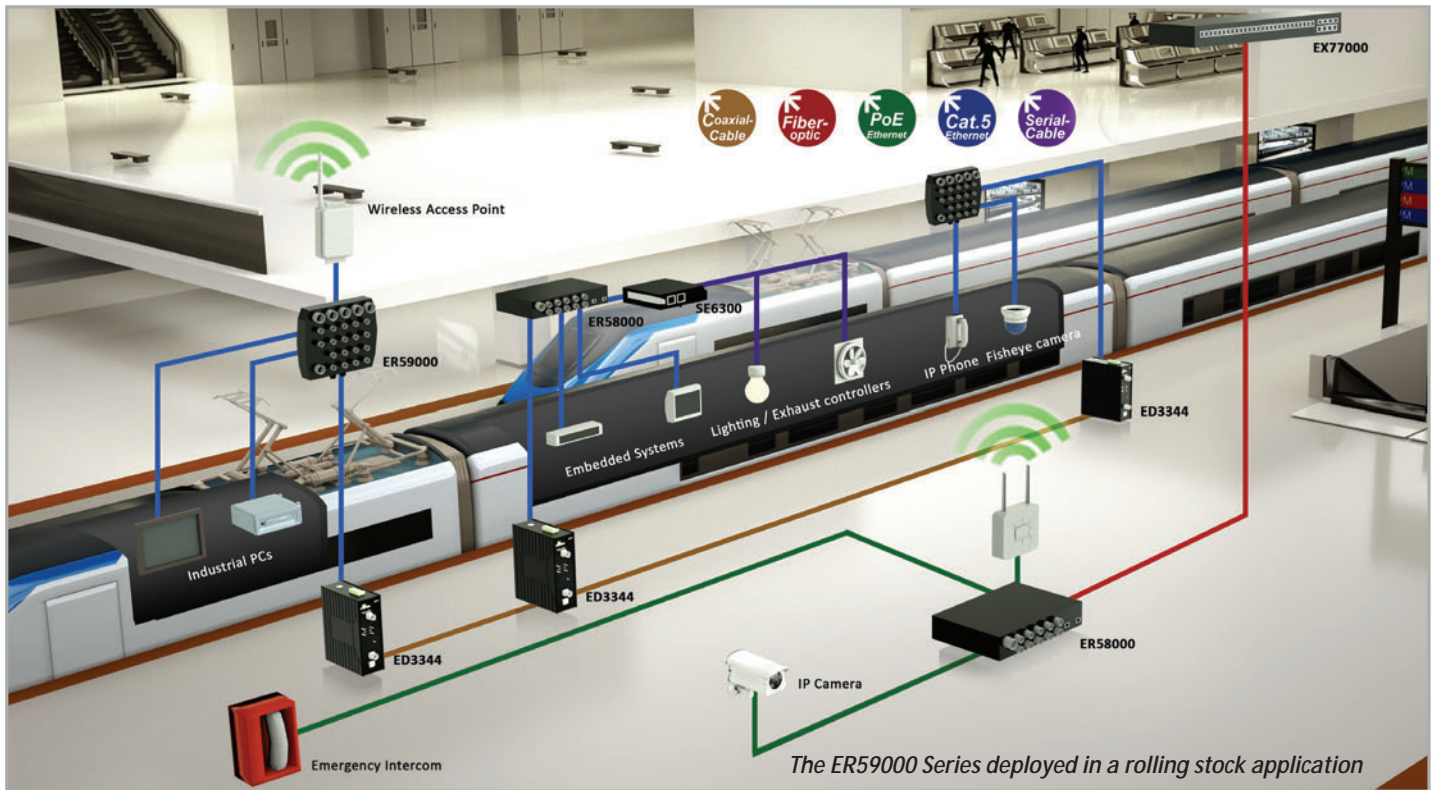

Dimensions

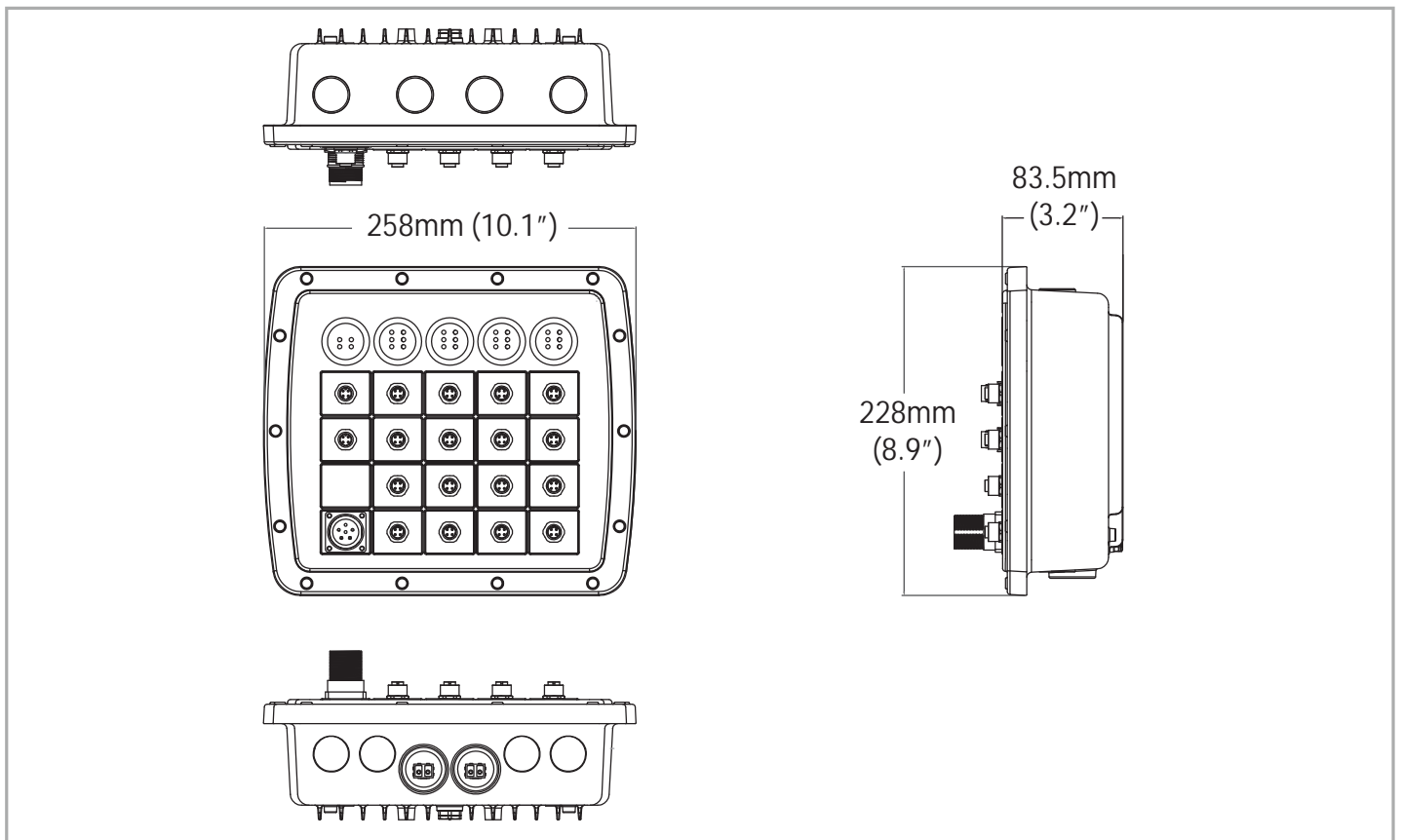

Ordering Information

Model

ER59402-20YZP	Hardened Managed 16-port 10/100BASE M12 (8 x PoE) with 2-port Gigabit LC Ethernet Switch
---------------	--

* Panel mounting kit included

Gigabit Port Options (Y)

1	10/100/1000BASE-TX
E	1000BASE-SX(LC) - 550m
M	1000BASE-SX (LC) - 10Km
N	1000BASE-LX (LC) - 20Km

* More Gigabit options also available upon request



Power Input Interface (Z)

T	12 to 48VDC, 18 to 30VAC (for non-PoE model)
G	52 to 57VDC (for PoE model)

PoE Type (P)

0	non-PoE
T	IEEE802.3at

Optional Accessories

96G-1618957XX		Power cable with 6pin female M23 connector, 2-Meter cable
ER58000-RJ454P		4-pin M12 D-code male to 10/100BASE-TX RJ45 interface, 3-Meter cable

ER58000 Series

Hardened Managed 8-port 10/100BASE M12 PoE with 2-port Gigabit M12 Ethernet Switch



Overview

EtherWAN's ER58000 Series provides a hardened 10-port switching platform supporting IEEE802.3at Power over Ethernet, high performance switching with robust management features required for railway transportation application.

The ER58000 Series is equipped with 8 x 10/100BASE-TX PoE with M12 connector, in combination with two Gigabit M12 ports. Compliant with EN50155 standard, the ER58000 Series is designed for rolling stock applications.

The IEEE802.3at PoE ports provide up to 30W/port with a total power budget of 120W, making the switch truly versatile for connecting with PoE Powered Devices (PD) with different bandwidth and power consumption requirements such as; outdoor PTZ dome cameras, wireless access points, and way-side communication devices.

Wall mountable, the ER58000 Series is equipped with EtherWAN's Alpha-Ring self-healing ring technology providing less than 15ms fault recovery time. Users are able to access management features such as port security, IGMP snooping, port-based VLAN, GARP protocols, link aggregation, via web browser, telnet, SSH, SNMP, RMON, TFTP, and RS-232 console interfaces. With the hardened specifications, the ER58000 Series is designed to operate at -40°C to 75°C in harsh environments, where high ESD, shock, and vibration may be present.

EtherWAN — "When Connectivity is Crucial."

Spotlight

• Railway Oriented

- Compliant with EN50155/EN50121-3-2/EN50121-4 railway applications

• M12 Connectors

- Built-in 8-port 10/100BASE M12 plus 2-port Gigabit M12/LC connectors

• Power over Ethernet (PoE)

- Provides 8-port PoE function with IEEE802.3at up to 30W per port

Software Features

Management

- Interface
 - CLI, Telnet and Web Browser
 - SNMP v1/v2c/v3
- Firmware and configuration upgrade and backup via TFTP
- Supports DHCP Server/Client
- RMON (Remote monitoring): group 1, 2, 3, 9
- Port mirroring: TX/RX and both
- NTP (Network Time Protocol) time synchronization
- IEEE802.1ab LLDP (Link Layer Discovery Protocol)

Security

- MAC address filtering
- Enable/disable port
- Storm control (broadcast and multicast types)
- IEEE802.1x LAN access control
- Remote authentication through RADIUS
- SSH for CLI and Telnet security
- SSL for web security
- Multi-level user account/password against unauthorized configuration

Quality of Service (QoS)

- Priority Queues: 4 queues per port
- Traffic classification based on IEEE802.1p CoS, DSCP, WRR (Weighted round robin) and strict mode
- Rate Limiting (Ingress/Egress)

Layer 2 Features

- Auto-negotiation for port speed and duplex mode
- Flow Control
 - IEEE802.3x full duplex mode
 - Back-Pressure half duplex mode
- Redundant Protocol
 - IEEE802.1D Spanning Tree Protocol (STP)
 - IEEE802.1w Rapid Spanning Tree Protocol (RSTP)
 - IEEE802.1s Multiple Spanning Tree Protocol (MSTP)
 - EtherWAN's α -Ring network fault recovery (<15ms) and α -Chain
- VLANs
 - Port-based VLANs
 - IEEE802.1Q Tag VLANs (128 groups, 4096 VID)
 - GVRP (GARP VLAN Registration Protocol)
 - GMRP (GARP Multicast Registration Protocol)
- Link Aggregation
 - Static Trunk (2 groups, support MAC base)
 - IEEE802.3ad Link Aggregation Control Protocol
- IGMP Snooping
 - IGMP snooping v1/v2/v3

Performance

- Switching Capability: 5.6 Gbps
- Packet Buffer Size: 2M bits
- MAC Address Table: 8K

Hardware Specifications

Technology

Standards

- IEEE802.3 10BASE-T
- IEEE802.3u 100BASE-TX/100BASE-FX
- IEEE802.3ab 1000BASE-T
- IEEE802.3z 1000BASE-SX/1000BASE-LX
- IEEE802.3x Full duplex and flow control
- IEEE802.1p QoS
- IEEE802.1Q Tag VLANs
- IEEE802.1w RSTP
- IEEE802.1x Port-based Network Access Control
- IEEE802.1s MSTP
- IEEE802.3ad LACP
- IEEE802.3af/at Power over Ethernet (PoE)

Forward and Filtering Rate

- 14,880pps for 10Mbps
- 148,810pps for 100Mbps
- 1,488,100pps for 1000Mbps

Packet Buffer Memory

- 2M bits

Processing Type

- Store-and-Forward
- Auto Negotiation
- Half-duplex back-pressure and IEEE802.3x full-duplex flow control
- Auto MDI/MDIX

Address Table Size

- 8192 MAC addresses

Power

Input

- Redundant power inputs:
M23: 24 - 48VDC

Power Consumption

- Device: Max. 11W (without PoE)
- PoE power budget (depends on power input): 120W Max.

PoE電力出力

- Port 1 to 8: IEEE802.3at, up to 30W/port

Protection

- Overload current protection
- Reverse polarity protection

Mechanical

Casing

- Metal Case
- IP50

Dimensions

- 288mm (W) x 161.5mm (D) x 64mm (H)
(11.3" (W) x 6.4" (D) x 2.5" (H))

Weight

- 2.3Kg (5.07lbs)

Installation

- Wall mounting

Interface

Ethernet Port

- 10/100BASE-M12 D-Code 4-pin Female: 8 ports
- Gigabit-M12 A-Code 8-pin Female/LC: 2 ports

Console Port

- One M12 port

LED Indicators

- Per Unit: Power 1 (Green)
Power 2 (Green)
- Per Port: Link/Activity (Green)

Alarm Contact

- One relay M12 A-Code 4-Pin Female output with current
1A @ 250 VAC

Environment

Operating Temperature

- -40°C to 75°C (-40°F to 167°F)
Tested @ -40°C to 85°C (-40°F to 185°F)

Storage Temperature

- -45°C to 85°C (-49°F to 185°F)

Ambient Relative Humidity

- 5% to 95% (non-condensing)

Regulatory Approvals

ISO

- Manufactured in an ISO9001 facility

EMI

FCC Part 15B, Class A

EN61000-6-4

EN55022

EN55011 (for EN50155)

EMS

EN61000-6-2

- EN61000-4-2 (ESD Standards)
- EN61000-4-3 (RFI Standards)
- EN61000-4-4 (Burst Standards)
- EN61000-4-5 (Surge Standards)
- EN61000-4-6 (Induced RFI Standards)
- EN61000-4-8 (Magnetic Field Standards)
- EN61000-4-9 (Pulsed magnetic field)

Environmental Test Compliance

IEC61373 (Vibration) for EN50155

IEC61373 (Shock) for EN50155

IEC600680-2-32 Ed (Free fall)

Industrial Compliance

EN50155

EN50121-3-2

EN50121-4

Application Diagram

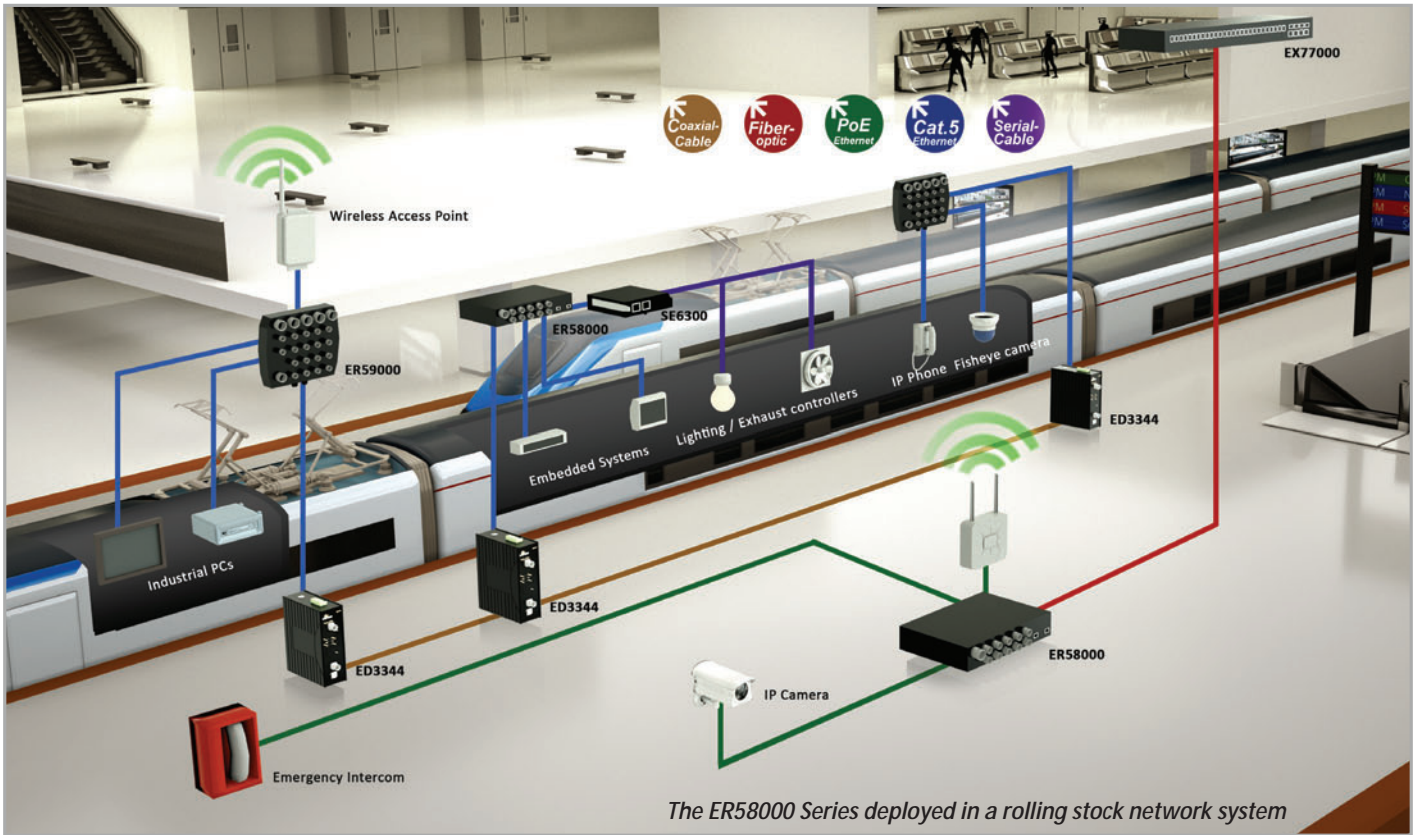

Dimensions

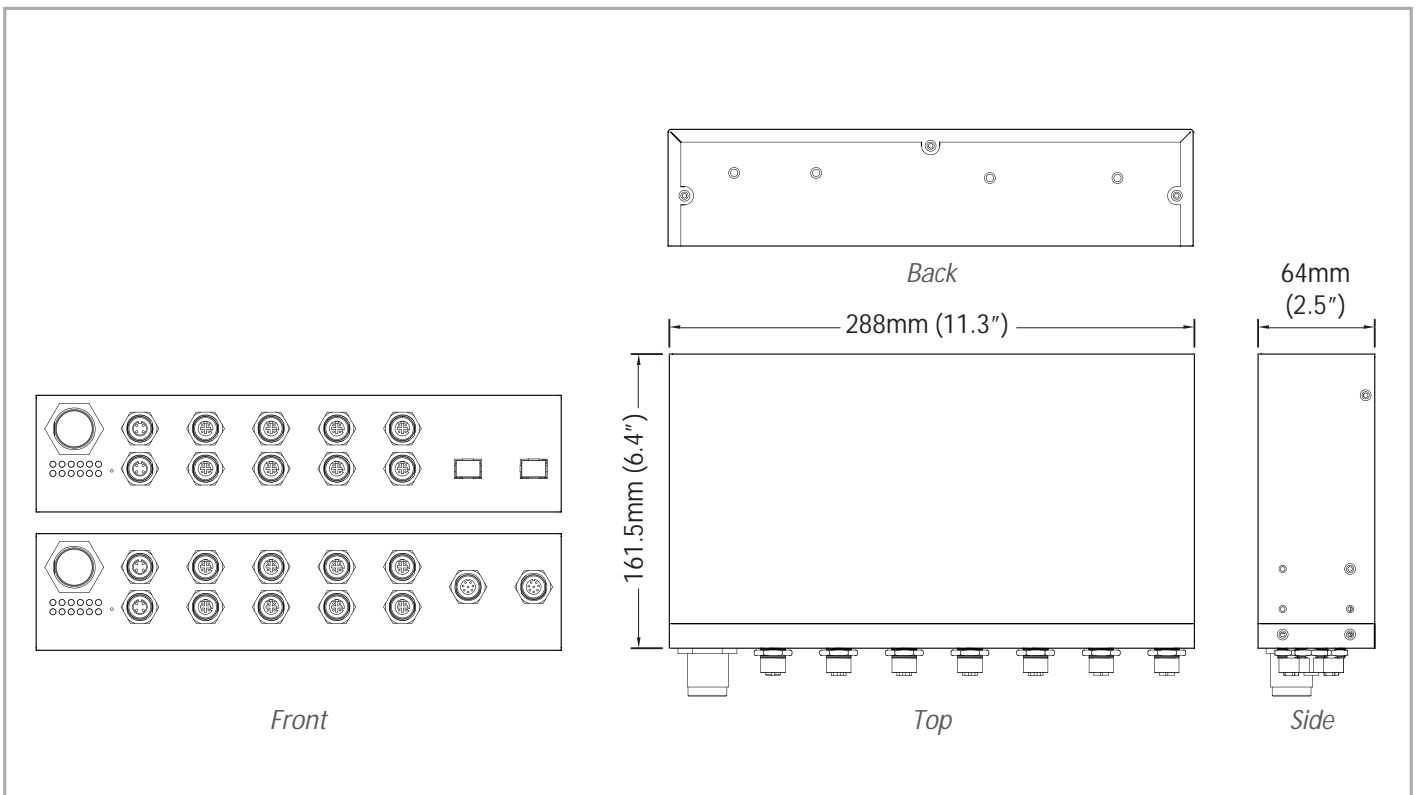

Ordering Information

Model

ER58802-20YHT	8-port 10/100BASE-M12 PoE + 2-port Gigabit Hardened Managed Ethernet Switch
---------------	---



* Panel mounting kit included

Gigabit Port Options (Y)

1	10/100/1000BASE-TX
E	1000BASE-SX (LC) - 550m
M	1000BASE-SX (LC) - 10Km
N	1000BASE-LX (LC) - 20Km

* More Gigabit options also available upon request

Optional Accessories

96G-S1N8A80WW		M23 Power Connector
96G-1618957XX		Power cable with 6-pin female M23 connector, 2-meter cable
ER58000-RJ454P		4-pin M12 D-code male to 10/100BASE-TX RJ45 interface, 3-meter cable
ER58000-RJ458P		8-pin M12 A-code male to 10/100/1000BASE-TX RJ45 interface, 3-meter cable

EX78900 Series

Hardened Managed 16-port (8 x PoE) Gigabit Ethernet Switch



- 8 X PoE — provides 60 watt Ultra PoE ports
- Power Budget: 240W

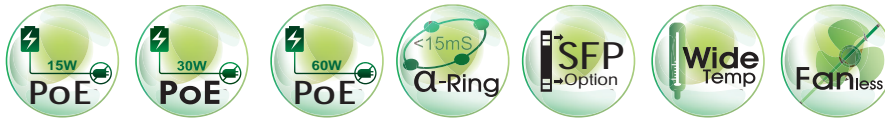

Overview

EtherWAN's EX78900 Series is a hardened DIN-rail mounted 16-port Gigabit switching platform. It features with 60W and IEEE802.3at/af Power over Ethernet combining with robust management features required for mission-critical and harsh environments where sustained connectivity is crucial.

The EX78900 Series is equipped with 12 x 10/100/1000 BASE-TX (8 x PoE port), in combination with 4 Gigabit SFP ports. The Ultra PoE ports provide up to 60W/port with a total power budget of 240W, making the switch truly versatile to connect with PoE Powered Devices (PD) with different bandwidth and power consumption requirements such as outdoor PTZ dome cameras, wireless access points, and way-side communication devices. The EX78900 Series is equipped with EtherWAN's Alpha-Ring self-healing technology, providing less than 15ms fault recovery time making it ideal for applications intolerant to interruption. Users are able to access management features such as port security, IGMP snooping, port-based VLAN, GARP protocols, link aggregation and ACL, via web browser, telnet, SSH, SNMP, RMON, TFTP, and RS-232 console interfaces.

With the hardened specifications, the EX78900 Series is designed to operate at -40°C to 75°C in harsh environments, where high ESD, shock, and vibration may be present.

EtherWAN — "When Connectivity is Crucial."

Spotlight

• Ultra PoE Switch

- Up to 12 ports with 8 Ports PoE, support 60W/ IEEE802.3af/at, and 4 Gigabit SFP ports for high-bandwidth communication

• Intelligent Management

- Optimize network performance with QoS, VLAN, and PoE scheduling, etc.

• Remote Secure Access

- IEEE802.1x, ACL and RADIUS support

Software Features

Management

- Interface
 - CLI, Telnet and Web Browser
 - SNMP v1/v2c/v3
- Firmware and configuration upgrade and backup via TFTP
- Supports DHCP Server/Client
- RMON (Remote monitoring): group 1, 2, 3, 9
- Port mirroring: TX/RX and both
- NTP (Network Time Protocol) time synchronization
- IEEE802.1ab LLDP (Link Layer Discovery Protocol)

Security

- MAC address filtering
- Enable/disable port
- Storm control (broadcast and multicast types)
- IEEE802.1x LAN access control
- Remote authentication through RADIUS
- SSH for CLI and Telnet security
- SSL for web security
- System log (remote/local)
- ACL

Quality of Service (QoS)

- Priority Queues: 4 queues per port
- Traffic classification based on IEEE802.1p CoS, DSCP, WRR (Weighted round robin) and strict mode
- Rate Limiting (Ingress/Egress)

Layer 2 Features

- Auto-negotiation for port speed and duplex mode
 - Flow Control
 - IEEE802.3x full duplex mode
 - Back-Pressure half duplex mode
- Redundant Protocol
 - IEEE802.1D Spanning Tree Protocol (STP)
 - IEEE802.1w Rapid Spanning Tree Protocol (RSTP)
 - IEEE802.1s Multiple Spanning Tree Protocol (MSTP)
 - EtherWAN's α -Ring network fault recovery <15ms
- VLANs
 - Port-based VLANs
 - IEEE802.1Q Tag VLANs (128 groups, 4096 VID)
 - GVRP (GARP VLAN Registration Protocol)
 - GMRP (GARP Multicast Registration Protocol)
- Link Aggregation
 - Static Trunk (4 groups, support MAC base)
 - IEEE802.3ad Link Aggregation Control Protocol
- IGMP Snooping
 - IGMP snooping v1/v2/v3

Performance

- Switching Capability: 16Gbps
- Packet Buffer Size: 12M bits
- MAC Address Table: 16K
- Jumbo Frame: 9216 bytes

Hardware Specifications

Technology

Standards

- IEEE802.3 10BASE-T
- IEEE802.3u 100BASE-TX/100BASE-FX
- IEEE802.3ab 1000BASE-T
- IEEE802.3z 1000BASE-SX/1000BASE-LX
- IEEE802.3x Full duplex and flow control
- IEEE802.1p QoS
- IEEE802.1Q Tag VLANs
- IEEE802.1w RSTP
- IEEE802.1x Port-based Network Access Control
- IEEE802.3af/at Power over Ethernet

Forward and Filtering Rate

- 14,880pps for 10Mbps
- 148,810pps for 100Mbps
- 1,488,100pps for 1000Mbps

Packet Buffer Memory

- 12M bits

Processing Type

- Store-and-Forward
- Auto Negotiation
- Half-duplex back-pressure and IEEE802.3x full-duplex flow control
- Auto MDI/MDIX

Jumbo Frame

- 9216 bytes

Address Table Size

- 16K MAC addresses

Power

Input

- Redundant power inputs:
Terminal Block: 52 - 57VDC

Power Consumption

- Device: Max. 20W (without PoE)

PoE Power Output

- PoE can be configured as:
 1. 6-port 15.4 W PoE and 2- port 60 watt PoE
 2. 8-port 30W PoE
 3. 4-port 10/100/1000 TX and 4-port 60 watt PoE
 4. Other PoE power level configuration can be done through firmware
- PoE power budget: 240W

Protection

- Overload current protection
- Reverse polarity protection

Mechanical

Casing

- Aluminum Case
- IP30

Dimensions

- 72mm (W) x 140mm (D) x 170mm (H)
(2.8"(W) x 5.5"(D)x 6.7"(H))

Weight

- 1.1Kg (2.42lbs.)

Installation

- DIN-Rail (Top hat type35mm), Rack, or Wall mounting

Interface

Ethernet Port

- 10/100/1000BASE-TX (PoE): 12 ports
- 1000BASE-SFP: 4 ports

Console Port

- Port: One DB9 RS-232 port

LED Indicators

- Per Unit: Power 1, Power 2
- Per PoE Port: PoE Status (Orange)
- Per Port: Link/Activity (Green)

Environment

Operating Temperature

- -40°C to 75°C (-40°F to 167°F)
Tested @ -40°C to 85°C (-40°F to 185°F)

Storage Temperature

- -40°C to 85°C (-40°F to 185°F)

Ambient Relative Humidity

- 5% to 95% (non-condensing)

Regulatory Approvals

ISO

- Manufactured in an ISO9001 facility

EMI

FCC Part 15B, Class A

EN61000-6-4

EN55022

EN61000-3-2

EN61000-3-3

EMS

EN61000-6-2

- EN61000-4-2 (ESD Standards)
- EN61000-4-3 (Radiated RFI Standards)
- EN61000-4-4 (Burst Standards)
- EN61000-4-5 (Surge Standards)
- EN61000-4-6 (Induced RFI Standards)
- EN61000-4-8 (Magnetic Field Standards)

Environmental Test Compliances

IEC60068-2-6 Fc (Vibration)

IEC60068-2-27 Ea (Shock)

IEC60068-2-32 Ed (Free fall)

Application Diagram

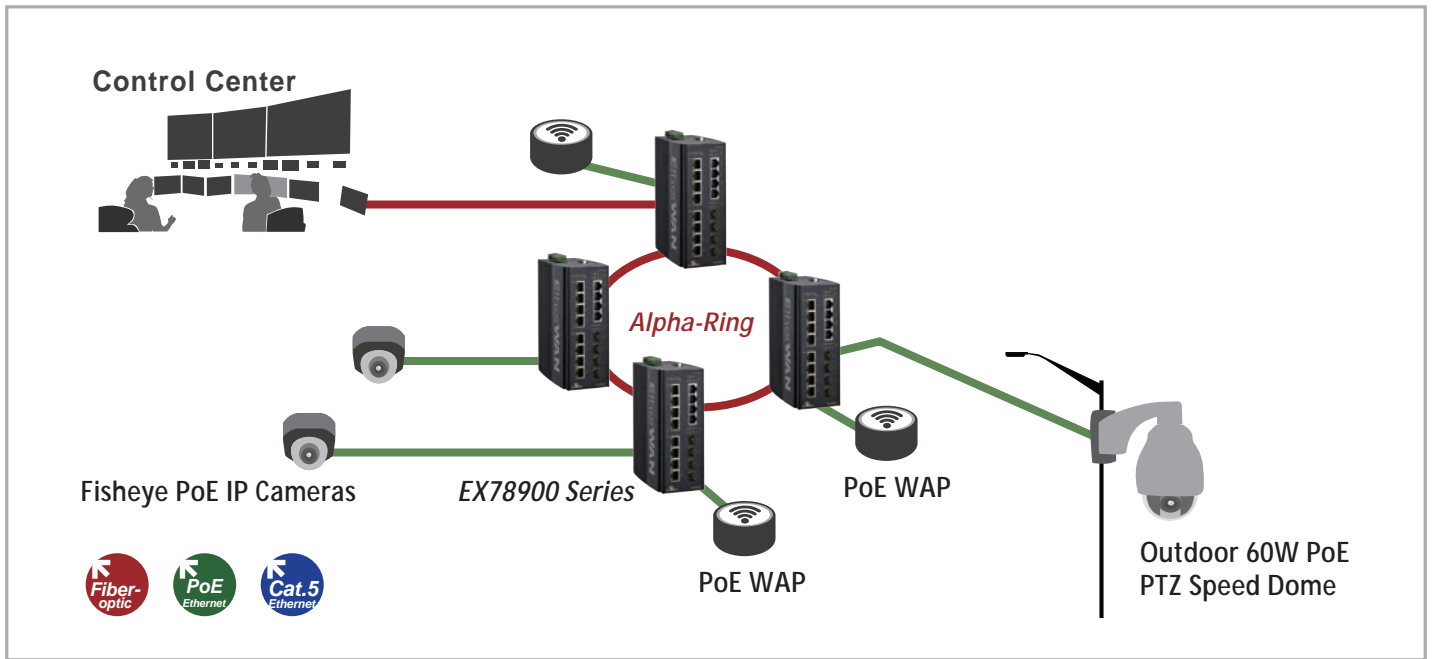

Dimensions

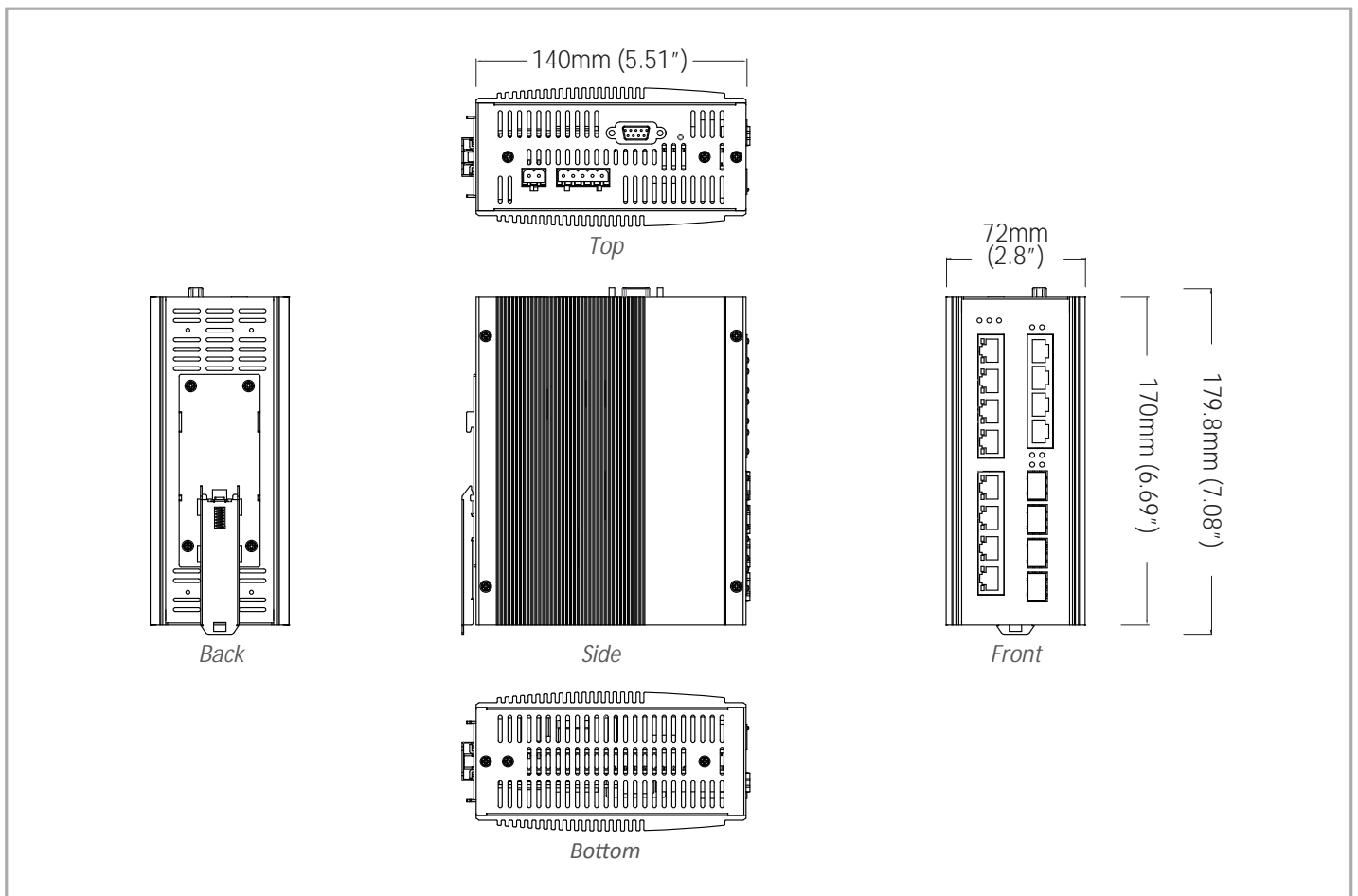

Ordering Information

Models

EX78931-0VB	12-Port 10/100/1000BASE-TX with 8-port PoE + 4-port Gigabit SFP Hardened Managed Ethernet Switch
--------------------	--

* DIN-Rail mounting kit included

Optional Accessories

SDR-480-48	480W/10A DIN-Rail 48VDC Industrial Power Supply (for terminal block)
-------------------	--

EX78602 Series

Hardened Managed 6-port 10/100BASE (4 x PoE + 2 x 60W PoE) and 2-port Gigabit Ethernet Switch



Overview

EtherWAN's EX78602 Series provides a hardened 8-port switching platform with 60W and IEEE802.3at/af Power over Ethernet combining high performance switching with robust management features required for mission-critical and harsh environments where sustained connectivity is crucial.

The EX78602 Series is equipped with 6 10/100BASE-TX PoE (4 x PoE 30W + 2 x 60W ports), in combination with two Gigabit SX/LX/BX/WDM Fiber ports with SFP options.

The Ultra PoE ports provide up to 60W/port with a total power budget of 180W, making the switch truly versatile for connecting with PoE Powered Devices (PD) with different bandwidth and power consumption requirements such as outdoor PTZ dome cameras, wireless access points, and way-side communication devices.

Din Rail mountable, the EX78602 Series is equipped with EtherWAN's Alpha-Ring self-healing ring technology providing less than 15ms fault recovery time. Users are able to access management features such as port security, IGMP snooping, port-based VLAN, GARP protocols, link aggregation, via web browser, telnet, SSH, SNMP, RMON, TFTP, and RS-232 console interfaces. With the hardened specifications, the EX78602 Series is designed to operate at -40°C to 75°C in harsh environments, where high ESD, shock, and vibration may be present.

EtherWAN — "When Connectivity is Crucial."

Spotlight

• Ultra High-Power PoE Switch

- Up to 2 ports with 60W PoE, 4-port PoE with IEEE802.3af/at, and 2 Gigabit (SX/LX/SFP) ports for high-bandwidth communication

• Intelligent Management

- Optimize network performance with QoS, VLAN, and PoE scheduling, etc. Network redundancy is secured by EtherWAN's α-Ring, with fault recovery time < 15ms

• Remote Secure Access

- IEEE802.1x, and RADIUS support

Software Features

Management

- Interface
 - CLI, Telnet and Web Browser
 - SNMP v1/v2c/v3
- Firmware and configuration upgrade and backup via TFTP
- Supports DHCP Server/Client
- RMON (Remote monitoring): group 1, 2, 3, 9
- Port mirroring: TX/RX and both
- NTP (Network Time Protocol) time synchronization
- IEEE802.1ab LLDP (Link Layer Discovery Protocol)

Security

- MAC address filtering
 - Enable/disable port
- Storm control (broadcast and multicast types)
- IEEE802.1x LAN access control
- Remote authentication through RADIUS
- SSH for CLI and Telnet security
- SSL for web security
- Multi-level user account/password against unauthorized configuration
- System log (remote/local)

Quality of Service (QoS)

- Priority Queues: 4 queues per port
- Traffic classification based on IEEE802.1p CoS, DSCP, WRR (Weighted round robin) and strict mode
- Rate Limiting (Ingress/Egress)

Layer 2 Features

- Auto-negotiation for port speed and duplex mode
- Flow Control
 - IEEE802.3x full duplex mode
 - Back-pressure half duplex mode
- Redundant Protocol
 - IEEE802.1D Spanning Tree Protocol (STP)
 - IEEE802.1w Rapid Spanning Tree Protocol (RSTP)
 - IEEE802.1s Multiple Spanning Tree Protocol (MSTP)
 - EtherWAN's Alpha-Ring network fault recovery (<15ms)
- VLANs
 - Port-based VLANs
 - IEEE802.1Q Tag VLANs (128 groups, 4096 VID)
 - GVRP (GARP VLAN Registration Protocol)
 - GMRP (GARP Multicast Registration Protocol)
- Link Aggregation
 - Static Trunk (2 groups, support MAC base)
 - IEEE802.3ad Link Aggregation Control Protocol
- IGMP Snooping
 - IGMP snooping v1/v2/v3

Performance

- Switching Capability: 5.2Gbps
- Packet Buffer Size: 2M bits
- MAC Address Table: 8K

Hardware Specifications

Technology

Standards

- IEEE802.3 10BASE-T
- IEEE802.3u 100BASE-TX/100BASE-FX
- IEEE802.3ab 1000BASE-T
- IEEE802.3z 1000BASE-SX/1000BASE-LX
- IEEE802.3x Full duplex and flow control
- IEEE802.1p QoS
- IEEE802.1Q Tag VLANs
- IEEE802.1w RSTP
- IEEE802.1x Port-based Network Access Control
- IEEE802.3af/at Power over Ethernet

Forward and Filtering Rate

- 14,880pps for 10Mbps
- 148,810pps for 100Mbps
- 1,488,100pps for 1000Mbps

Packet Buffer Memory

- 2M bits

Processing Type

- Store-and-Forward
- Auto Negotiation
- Half-duplex back-pressure and IEEE802.3x full-duplex flow control
- Auto MDI/MDIX

Address Table Size

- 8192 MAC addresses

Power

Input

- Redundant power inputs:
Terminal block: 55 (52 - 57) VDC
DC Jack: 55 (52 - 57) VDC

Power Consumption

- Device: Max. 15W without PoE
- Total PoE power budget: 180W Max. depending on power input

Protection

- Overload current protection
- Reverse polarity protection

Mechanical

Casing

- Aluminum Case
- IP30

Dimensions

- 71.4mm (W) x 140mm (D) x 170mm (H)
(2.85" (W) x 5.6" (D) x 6.8" (H))

Weight

- 1.7Kg (3.74lbs.)

Installation

- DIN-Rail (Top hat type35mm), Rack, or Wall mounting

Interface

Ethernet Port

- 10/100BASE-TX (PoE): 6 ports
Port 1 to port 4: Up to 30W/ea
Port 5 to port 6: Up to 60W/ea
- Gigabit: 2 ports

Console Port

- Port: One DB9 RS-232 port

LED Indicators

- Per Unit: Power 1 (Green)
Power 2 (Green)
Power 3 (Green)
- Per Port: Link/Activity (Green)
- Per PoE Port: PoE Status (Orange)

Environment

Operating Temperature

- -40°C to 75°C (-40°F to 167°F)
Tested @ -40°C to 85°C (-40°F to 185°F)

Storage Temperature

- -40°C to 85°C (-40°F to 185°F)

Ambient Relative Humidity

- 5% to 95% (non-condensing)

Regulatory Approvals

ISO

- Manufactured in an ISO9001 facility

EMI

FCC Part 15B, Class A

EN61000-6-4

EN55022

EN61000-3-2

EN61000-3-3

EMS

EN61000-6-2

- EN61000-4-2 (ESD Standards)
- EN61000-4-3 (Radiated RFI Standards)
- EN61000-4-4 (Burst Standards)
- EN61000-4-5 (Surge Standards)
- EN61000-4-6 (Induced RFI Standards)
- EN61000-4-8 (Magnetic Field Standards)

Environmental Test Compliances

IEC60068-2-6 Fc (Vibration)

IEC60068-2-27 Ea (Shock)

IEC60068-2-32 Ed (Free fall)

Application Diagram

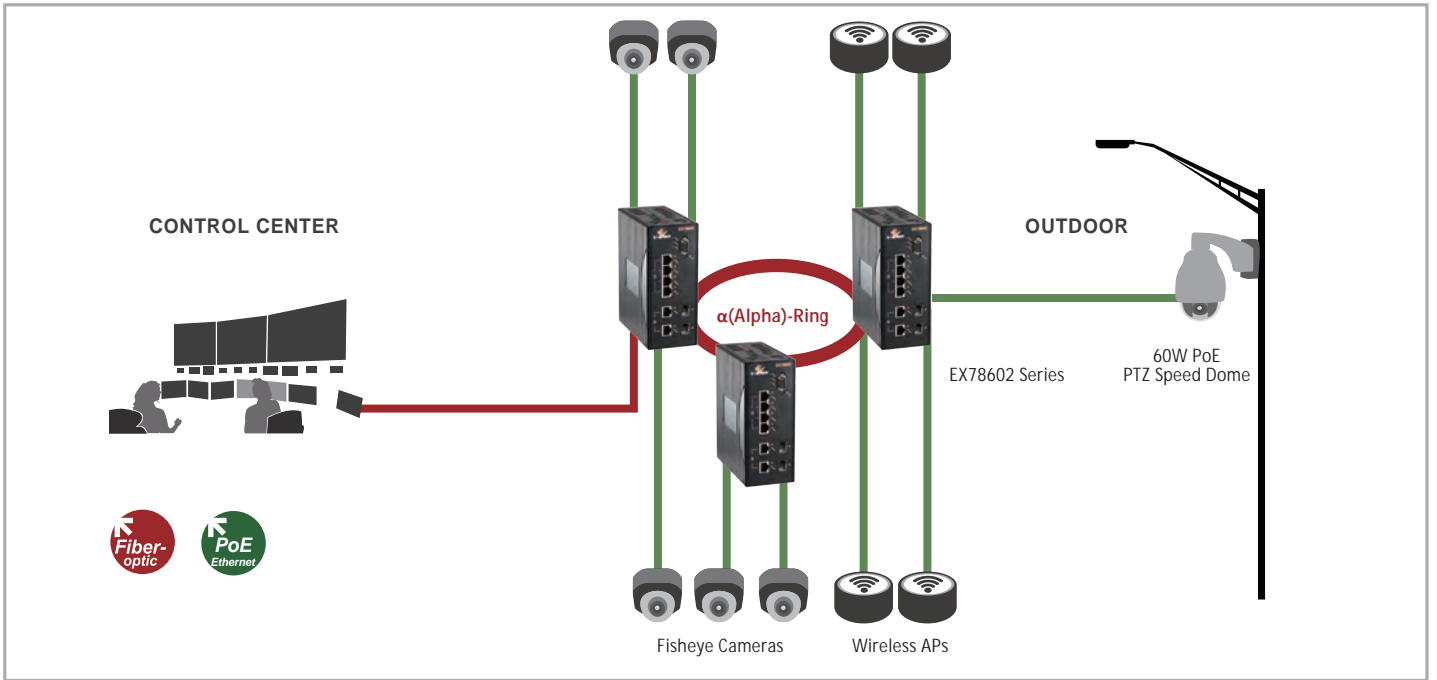

Dimensions

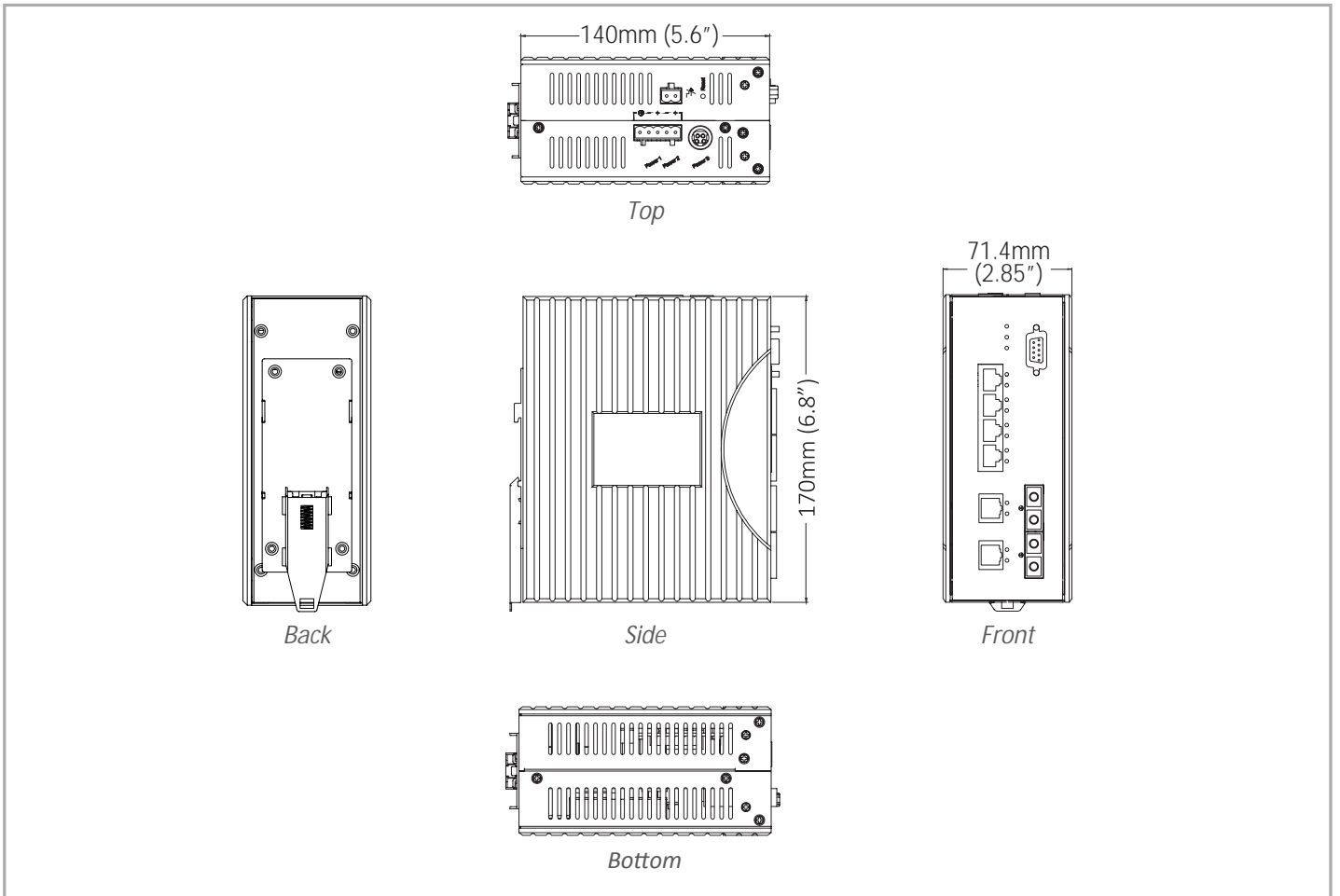

Ordering Information

Model

EX78602-01B	6-port 10/100BASE-TX PoE (4 x 30W + 2 x 60W) and 2-port 10/100/1000BASE-T Hardened Managed Ethernet Switch
EX78602-0VB	6-port 10/100BASE-TX PoE (4 x 30W + 2 x 60W) and 2-port Gigabit SFP Hardened Managed Ethernet Switch
EX78602-0YB	6-port 10/100BASE-TX PoE (4 x 30W + 2 x 60W) and 2-port Gigabit Hardened Managed Ethernet Switch

* DIN-Rail mounting kit included

Gigabit Port Options (Y)

1	10/100/1000BASE-TX
3	1000BASE-SX(SC) - 550m
4	1000BASE-SX (SC) - 2Km
5	1000BASE-SX (ST) - 550m
8	1000BASE-SX (ST) - 2Km
A	1000BASE-LX (SC) - 10Km
B	1000BASE-LX (SC) - 20Km
R	1000BASE-BX (SC) WDM - TX: 1310nm/RX: 1550nm - 20Km
S	1000BASE-BX (SC) WDM - TX: 1550nm/RX: 1310nm - 20Km
V	1000BASE SFP (DDM)

Optional Accessories

KP-AA96-480	Panel Mounting Kits
SDR-240-48	240W/5A DIN-Rail 48VDC Industrial Power Supply (for terminal block)

EX78000 Series

Hardened Managed 10-port 10/100BASE (8 x PoE) and 2-port Gigabit Ethernet Switch



Overview

EtherWAN's EX78000 Series provides a hardened 12-port switching platform supporting IEEE802.3at Power over Ethernet, high performance switching with robust management features required for mission-critical and harsh environments where sustained connectivity is crucial.

The EX78000 Series is equipped with 8 10/100BASE-TX PoE ports, in combination with two Gigabit SX/LX/BX/WDM Fiber ports with SFP options. The IEEE802.3at PoE ports provide up to 30W/port with a total power budget of 180W, making the switch truly versatile for connecting with PoE Powered Devices (PD) with different bandwidth and power consumption requirements such as outdoor PTZ dome cameras, wireless access points, and way-side communication devices.

Din rail mountable, the EX78000 Series is equipped with EtherWAN's Alpha-Ring self-healing ring technology providing less than 15ms fault recovery time. Users are able to access management features such as port security, IGMP snooping, port-based VLAN, GARP protocols, link aggregation, via web browser, telnet, SSH, SNMP, RMON, TFTP, and RS-232 console interfaces. With the hardened specifications, the EX78000 Series is designed to operate at -40°C to 75°C in harsh environments, where high ESD, shock, and vibration may be present.

EtherWAN — "When Connectivity is Crucial."

Spotlight

• Versatile PoE Connectivity

- 10-port 10/100BASE-TX/FX/BX/SFP plus 2-port Gigabit-TX/SX/LX/SFP
- Port 1 to 8 supports IEEE802.3af or IEEE802.3at Power over Ethernet

• Hardened Grade

- Wide operating temperature range From -40°C to 75°C (-40°F to 167°F) for extreme environments
- Fanless and ruggedized housing
- High shock and electric noise immunity
- Complies with NEMA TS2 for traffic control equipment

• Secure Remote Access

- IEEE802.1x and RADIUS support

Software Features

Management

- Interface
 - CLI, Telnet and Web Browser
 - SNMP v1/v2c/v3
- Firmware and configuration upgrade and backup via TFTP
- Supports DHCP Server/Client
- RMON (Remote monitoring): group 1, 2, 3, 9
- Port mirroring: TX/RX and both
- SFP transceivers support Digital Diagnostics Monitoring (DDM)
- NTP (Network Time Protocol) time synchronization
- IEEE802.1ab LLDP (Link Layer Discovery Protocol)

Security

- MAC address filtering
- Enable/disable port
- Storm control (broadcast and multicast types)
- IEEE802.1x LAN access control
- Remote authentication through RADIUS
- SSH for CLI and Telnet security
- SSL for web security
- Multi-level user account/password against unauthorized configuration
- System log (remote/local)

Quality of Service (QoS)

- Priority Queues: 4 queues per port
- Traffic classification based on IEEE802.1p CoS, DSCP, WRR (Weighted round robin) and strict mode
- Rate Limiting (Ingress/Egress)

Layer 2 Features

- Auto-negotiation for port speed and duplex mode
- Flow Control
 - IEEE802.3x full duplex mode
 - Back-Pressure half duplex mode
- Redundant Protocol
 - IEEE802.1D Spanning Tree Protocol (STP)
 - IEEE802.1w Rapid Spanning Tree Protocol (RSTP)
 - IEEE802.1s Multiple Spanning Tree Protocol (MSTP)
 - EtherWAN's Alpha-Ring network fault recovery (<15ms)
- VLANs
 - Port-based VLANs
 - IEEE802.1Q Tag VLANs (128 groups, 4096 VID)
 - GVRP (GARP VLAN Registration Protocol)
 - GMRP (GARP Multicast Registration Protocol)
- Link Aggregation
 - Static Trunk (2 groups, support MAC base)
 - IEEE802.3ad Link Aggregation Control Protocol
- IGMP Snooping
 - IGMP snooping v1/v2/v3

Performance

- Switching Capability: 6Gbps
- Packet Buffer Size: 2M
- MAC Address Table: 8K

Hardware Specifications

Technology

Standards

- IEEE802.3 10BASE-T
- IEEE802.3u 100BASE-TX/100BASE-FX
- IEEE802.3ab 1000BASE-T
- IEEE802.3z 1000BASE-SX/1000BASE-LX
- IEEE802.3x Full duplex and flow control
- IEEE802.1p QoS
- IEEE802.1Q Tag VLANs
- IEEE802.1w RSTP
- IEEE802.1x Port-based Network Access Control
- IEEE802.3af/at Power over Ethernet (PoE)

Forward and Filtering Rate

- 14,880pps for 10Mbps
- 148,810pps for 100Mbps
- 1,488,100pps for 1000Mbps

Packet Buffer Memory

- 2M bits

Processing Type

- Store-and-Forward
- Auto Negotiation
- Half-duplex back-pressure and IEEE802.3x full-duplex flow control
- Auto MDI/MDIX

Address Table Size

- 8192 MAC addresses

Power

Input

- Redundant power input:
Terminal Block: 47 - 57VDC
DC Jack: 47 - 57VDC

Power Consumption

- Device: Max. 15W (without PoE)
- PoE power budget (depends on power input):
181.6W Max.

PoE Power Output

- Port 1 to 8 support PoE
- IEEE802.3af: up to 15.4W/port, 47 - 57VDC.
- IEEE802.3at: up to 30W/port, 50 - 57VDC

Protection

- Overload current protection
- Reverse polarity protection

Mechanical

Casing

- Metal Case
- IP30

Dimensions

- 71.4mm (W) x 140mm (D) x 170mm (H)
(2.85" (W) x 5.6" (D) x 6.8" (H))

Weight

- 1.7Kg (3.74lbs.)

Installation

- Din-Rail (Top hat type 35mm) or Wall mounting

Interface

Ethernet Port

- 10/100BASE-TX (PoE): 8 or 4 ports
- 100BASE-FX: 0, 2 or 4 ports
- Gigabit: 0, 1 or 2 ports

Console Port

- Port: One DB9 RS-232 port

LED Indicators

- Per Unit: Power 1, Power 2, Power 3
- Per Port: Link/Activity (Green)
- Per PoE Port: PoE (Orange)

Environment

Operating Temperature

- -40°C to 75°C (-40°F to 167°F)
Tested @ -40°C to 85°C (-40°F to 185°F)

Storage Temperature

- -45°C to 85°C (-49°F to 185°F)

Ambient Relative Humidity

- 5% to 95% (non-condensing)

Regulatory Approvals

ISO

- Manufactured in an ISO9001 facility

Safety

UL508

EMI

FCC Part 15B, Class A

EN61000-6-4

EN55022

EN61000-3-2

EN61000-3-3

EMS

EN61000-6-2

- EN61000-4-2 (ESD Standards)
- EN61000-4-3 (Radiated RFI Standards)
- EN61000-4-4 (Burst Standards)
- EN61000-4-5 (Surge Standards)
- EN61000-4-6 (Induced RFI Standards)
- EN61000-4-8 (Magnetic Field Standards)

Environmental Test Compliance

IEC60068-2-6 Fc (Vibration)

IEC60068-2-27 Ea (Shock)

IEC60068-2-32 Ed (Free fall)

Industrial Compliance

NEMA TS2

Application Diagram

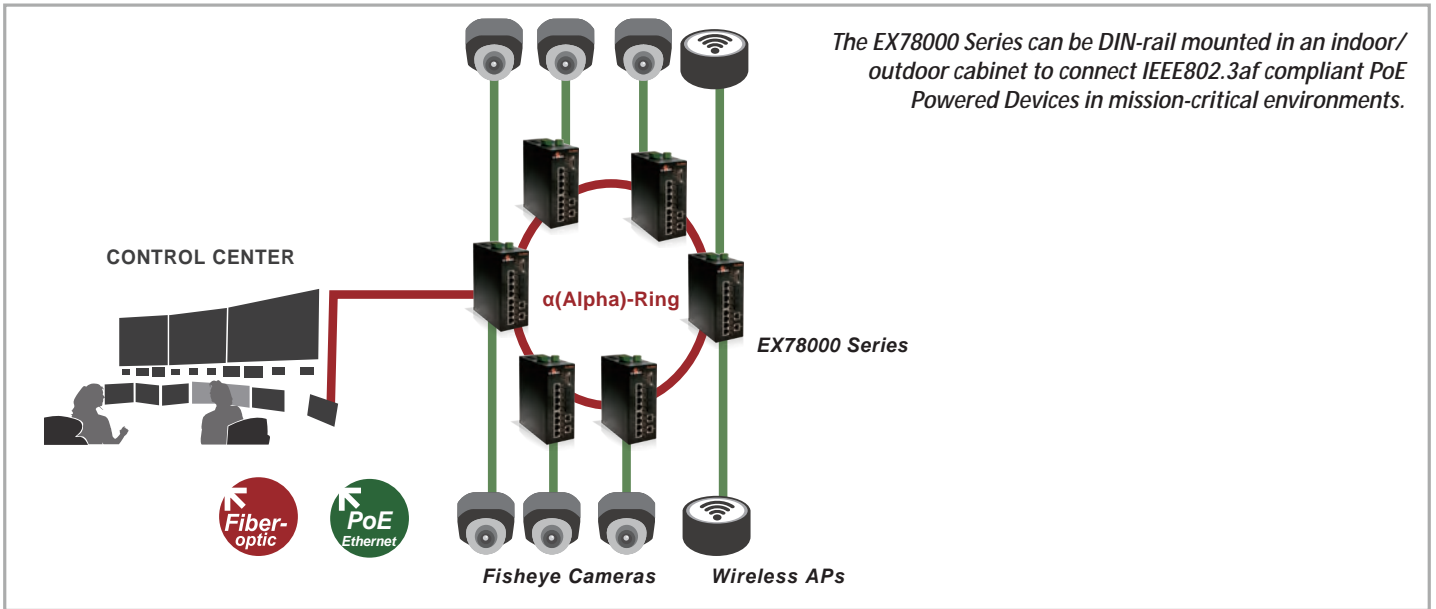

Dimensions

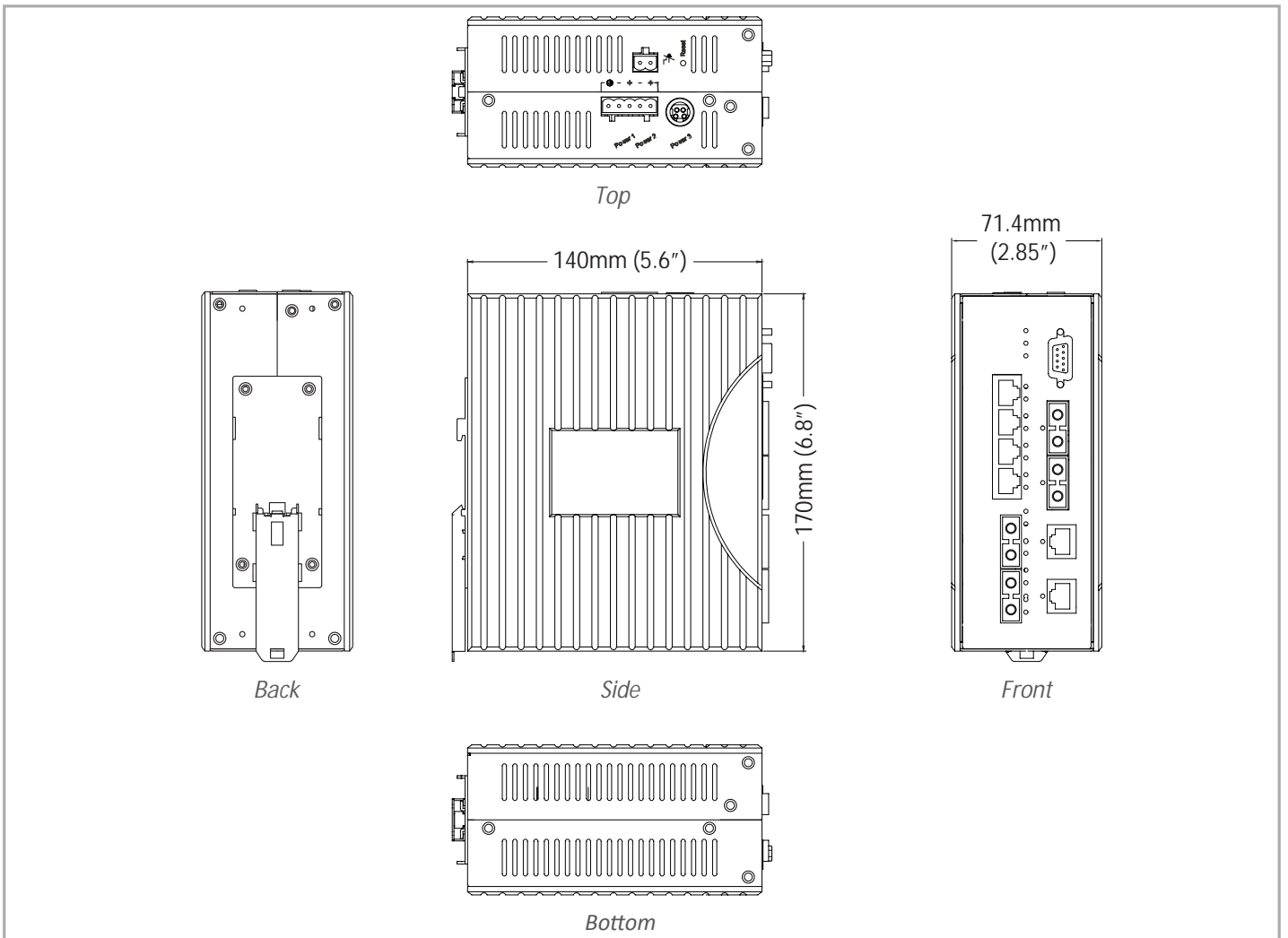

Ordering Information

Model

EX78400-00B-P	4-port 10/100BASE-TX PoE Hardened Managed Ethernet Switch
EX78401-0YB-P	4-port 10/100BASE-TX PoE + 1-port Gigabit Hardened Managed Ethernet Switch
EX78402-0YB-P	4-port 10/100BASE-TX PoE + 2-port Gigabit Hardened Managed Ethernet Switch
EX78420-X0B-P	4-port 10/100BASE-TX PoE + 2-port 100BASE-FX Hardened Managed Ethernet Switch
EX78440-X0B-P	4-port 10/100BASE-TX PoE + 4-port 100BASE-FX Hardened Managed Ethernet Switch
EX78441-XYB-P	4-port 10/100BASE-TX PoE + 4-port 100BASE-FX + 1-port Gigabit Hardened Managed Ethernet Switch
EX78442-XYB-P	4-port 10/100BASE-TX PoE + 4-port 100BASE-FX + 2-port Gigabit Hardened Managed Ethernet Switch
EX78800-00B-P	8-port 10/100BASE-TX PoE Hardened Managed Ethernet Switch
EX78801-0YB-P	8-port 10/100BASE-TX PoE + 1-port Gigabit Hardened Managed Ethernet Switch
EX78802-0YB-P	8-port 10/100BASE-TX PoE + 2-port Gigabit Hardened Managed Ethernet Switch
EX78820-X0B-P	8-port 10/100BASE-TX PoE + 2-port 100BASE-FX Hardened Managed Ethernet Switch
EX78821-XYB-P	8-port 10/100BASE-TX PoE + 2-port 100BASE-FX + 1-port Gigabit Hardened Managed Ethernet Switch
EX78822-XYB-P	8-port 10/100BASE-TX PoE + 2-port 100BASE-FX + 2-port Gigabit Hardened Managed Ethernet Switch

* Rack mounting kit included

100FX Fiber Options (X)

1	Multi Mode (SC) - 2Km
2	Multi Mode (ST) - 2Km
6	Multi Mode (SC) WDM-TX:1310nm/RX:1550nm - 2Km
7	Multi Mode (SC) WDM-TX:1550nm/RX:1310nm - 2Km
8	Multi Mode (SC) WDM-TX:1310nm/RX:1550nm - 5Km
9	Multi Mode (SC) WDM-TX:1550nm/RX:1310nm - 5Km
A	Single Mode (SC) - 20Km
B	Single Mode (SC) - 40Km
F	Single Mode (FC) - 20Km
H	Single Mode (ST) - 20Km
P	Single Mode (SC) WDM-TX:1310nm/RX:1550nm - 20Km
Q	Single Mode (SC) WDM-TX:1550nm/RX:1310nm - 20Km
R	Single Mode (SC) WDM-TX:1310nm/RX:1550nm - 40Km
V	100BASE SFP (DDM)

*More 100FX Fiber options also available upon request.

Gigabit Port Options (Y)

1	10/100/1000BASE-TX
3	1000BASE-SX(SC) - 550m
4	1000BASE-SX (SC) - 2Km
5	1000BASE-SX (ST) - 550m
A	1000BASE-LX (SC) - 10Km
B	1000BASE-LX (SC) - 20Km
R	1000BASE-BX (SC) WDM-TX:1310nm/RX:1550nm - 20Km
S	1000BASE-BX (SC) WDM-TX:1550nm/RX:1310nm - 20Km
V	1000BASE SFP (DDM)

* More Gigabit options also available upon request.

Ordering Information - continued

PoE Type (P)

T	4 ports IEEE802.3at & 4 ports IEEE802.3af
T6	6 ports IEEE802.3at only without IEEE802.3af on others

**If no alphabet specified, the model has 8 ports IEEE802.3af*

Optional Accessories

DD-85-48	85W/1.78A 48VDC Industrial Power Supply (for terminal block)
DR-75-48	75W/1.6A DIN-Rail 48VDC Industrial Power Supply (for terminal block)
DR-120-48	120W/2.5A DIN-Rail 48VDC Industrial Power Supply (for terminal block)
SDR-240-48	240W/5A DIN-Rail 48VDC Industrial Power Supply

EX70900 Series

Hardened Managed 8-port Gigabit Ethernet Switch



Overview

EtherWAN's EX70900 Series provides a Hardened Fully Managed 8-port switching platform combining high performance switching backbone with robust and secure management features required for mission critical and harsh environments where sustained connectivity is crucial.

Mountable on a DIN-Rail, the EX70900 Series is a full Gigabit hardened managed switch, featured with 6 ports of 10/100/1000BASE-TX, in combination with up to two SFP Combo port options.

Users are able to access management features such as; port security, IGMP snooping, VLANs, GARP protocols, LACP to name a few, via web browser, Telnet, SNMP, RMON, TFTP, and RS-232 console interfaces. With its hardened-grade specifications and IEC61850 certifications, the EX70900 Series is capable of operating under high EMI environments at the temperatures ranging from -40°C to 75°C, making it an ideal choice for harsh applications.

EtherWAN – "When Connectivity is Crucial."

Spotlight

• Full Gigabit Connectivity

- Managed Hardened 8-port Gigabit Ethernet switch with either copper, SC, ST or LC connectors available

• Intelligent Data Management

- Optimize network performance with QoS, VLAN etc.

• Compliance with IEC61850-3

- For installations with high EMS requirements

• Energy Efficient Ethernet (EEE)

- Supports IEEE802.3az standard

Software Features

Management

- Interface
 - CLI, Telnet and Web Browser
 - SNMP v1/v2c/v3
- Firmware and configuration upgrade and backup via TFTP
- Supports DHCP Server/Client
- RMON (Remote monitoring): group 1, 2, 3, 9
- Port mirroring: TX/RX and both
- SFP transceivers support Digital Diagnostics Monitoring (DDM)
- NTP (Network Time Protocol) time synchronization
- IEEE802.1ab LLDP (Link Layer Discovery Protocol)

Security

- MAC address filtering
 - Enable/disable port
- Storm control (broadcast and multicast types)
- IEEE802.1x LAN access control
- Remote authentication through RADIUS
- SSH for CLI and Telnet security
- SSL for web security
- Multi-level user account/password against unauthorized configuration
- System log (remote/local)

Quality of Service (QoS)

- Priority Queues: 4 queues per port
- Traffic classification based on IEEE802.1p CoS, DSCP, WRR (Weighted round robin) and strict mode
- Rate Limiting (Ingress/Egress)

Layer 2 Features

- Auto-negotiation for port speed and duplex mode
- Flow Control
 - IEEE802.3x full duplex mode
 - Back-Pressure half duplex mode
- Redundant Protocol
 - IEEE802.1D Spanning Tree Protocol (STP)
 - IEEE802.1w Rapid Spanning Tree Protocol (RSTP)
 - IEEE802.1s Multiple Spanning Tree Protocol (MSTP)
- VLANs
 - Port-based VLANs
 - IEEE802.1Q Tag VLANs (128 groups, 4096 VID)
 - GVRP (GARP VLAN Registration Protocol)
 - GMRP (GARP Multicast Registration Protocol)
- Link Aggregation
 - Static Trunk (2 groups, support MAC base)
 - IEEE802.3ad Link Aggregation Control Protocol
- IGMP Snooping
 - IGMP snooping v1/v2/v3

Performance

- Switching Capability: 16Gbps
- Packet Buffer Size: 1.5M bits
- MAC Address Table: 4K

Hardware Specifications

Technology

Standards

- IEEE802.3 10BASE-T
- IEEE802.3u 100BASE-TX/100BASE-FX
- IEEE802.3ab 1000BASE-T
- IEEE802.3az EEE
- IEEE802.3z 1000BASE-SX/1000BASE-LX
- IEEE802.3x Full duplex and flow control
- IEEE802.1p QoS
- IEEE802.1Q Tag VLANs
- IEEE802.1w RSTP
- IEEE802.1x Port-based Network Access Control

Forward and Filtering Rate

- 14,880pps for 10Mbps
- 148,810pps for 100Mbps
- 1,488,100pps for 1000Mbps

Packet Buffer Memory

- 1.5M bits

Processing Type

- Store-and-Forward
- Half-duplex back-pressure and IEEE802.3x full-duplex flow control

Address Table Size

- 4096 MAC addresses

Power

Input

- Redundant power inputs:
 - 12 - 48VDC (Terminal Block)
 - 12VDC (DC Jack)

Power Consumption

- 10.2W Max., 0.85A @ 12VDC

Protection

- Overload current protection
- Reverse polarity protection

Mechanical

Casing

- Aluminum Case
- IP30

Dimensions

- 66mm (W) x 125mm (D) x 145mm (H)
(2.64" (W) x 4.92" (D) x 5.7" (H))

Weight

- 1.1Kg (2.42lbs.)

Installation

- DIN-Rail (Top hat type 35mm) or Wall mounting

Interface

Ethernet Port

- 10/100/1000BASE-TX: 8, 7, or 6 ports
- 1000BASE-SX/LX/SFP: 0, 1, or 2 ports

Console Port

- Port: One DB9 RS-232 port

LED Indicators

- Per Unit:
 - Power Status (Power 1, Power 2, Power 3)
 - Alarm
- Per Port: Link/Activity

Alarm Contact

- One relay output with current 1A @ 24VDC

Environment

Operating Temperature

- -40°C to 75°C (14°F to 167°F)
Tested @ -40°C to 85°C (-40°F to 185°F)

Storage Temperature

- -40°C to 85°C (-40°F to 185°F)

Ambient Relative Humidity

- 5% to 95% (non-condensing)

Regulatory Approvals

ISO

- Manufactured in an ISO9001 facility

Safety

UL508

EMI

FCC Part 15B, Class A

EN61000-6-4

EN61000-3-2

EN61000-3-3

EMS

EN61000-6-2

- EN61000-4-2 (ESD Standards)
- EN61000-4-3 (Radiated RFI Standards)
- EN61000-4-4 (Burst Standards)
- EN61000-4-5 (Surge Standards)
- EN61000-4-6 (Induced RFI Standards)
- EN61000-4-8 (Magnetic Field Standards)

Environmental Test Compliance

IEC60068-2-6 Fc (Vibration Resistance)

IEC60068-2-27 Ea (Shock)

FED STD 101C Method 5007.1 (Free fall w/ package)

Industrial Compliance

IEC61850-3

Application Diagram

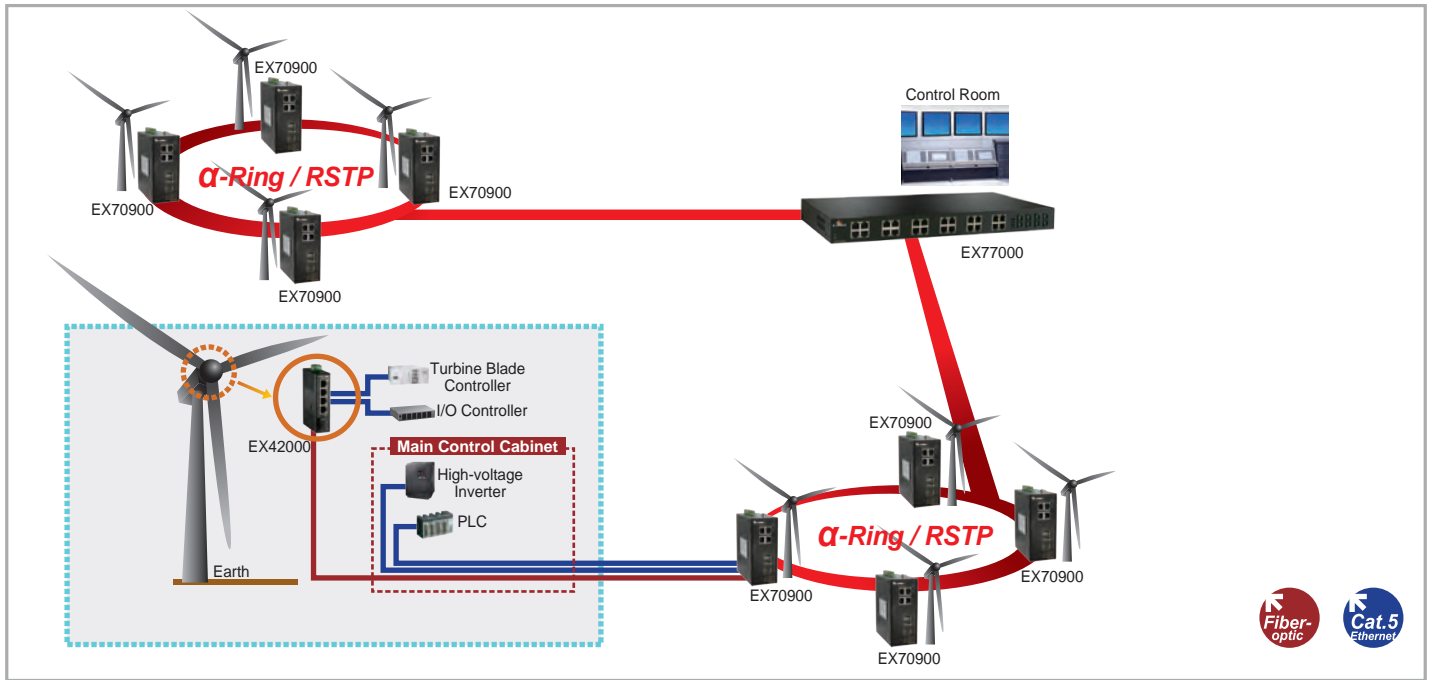

Dimensions

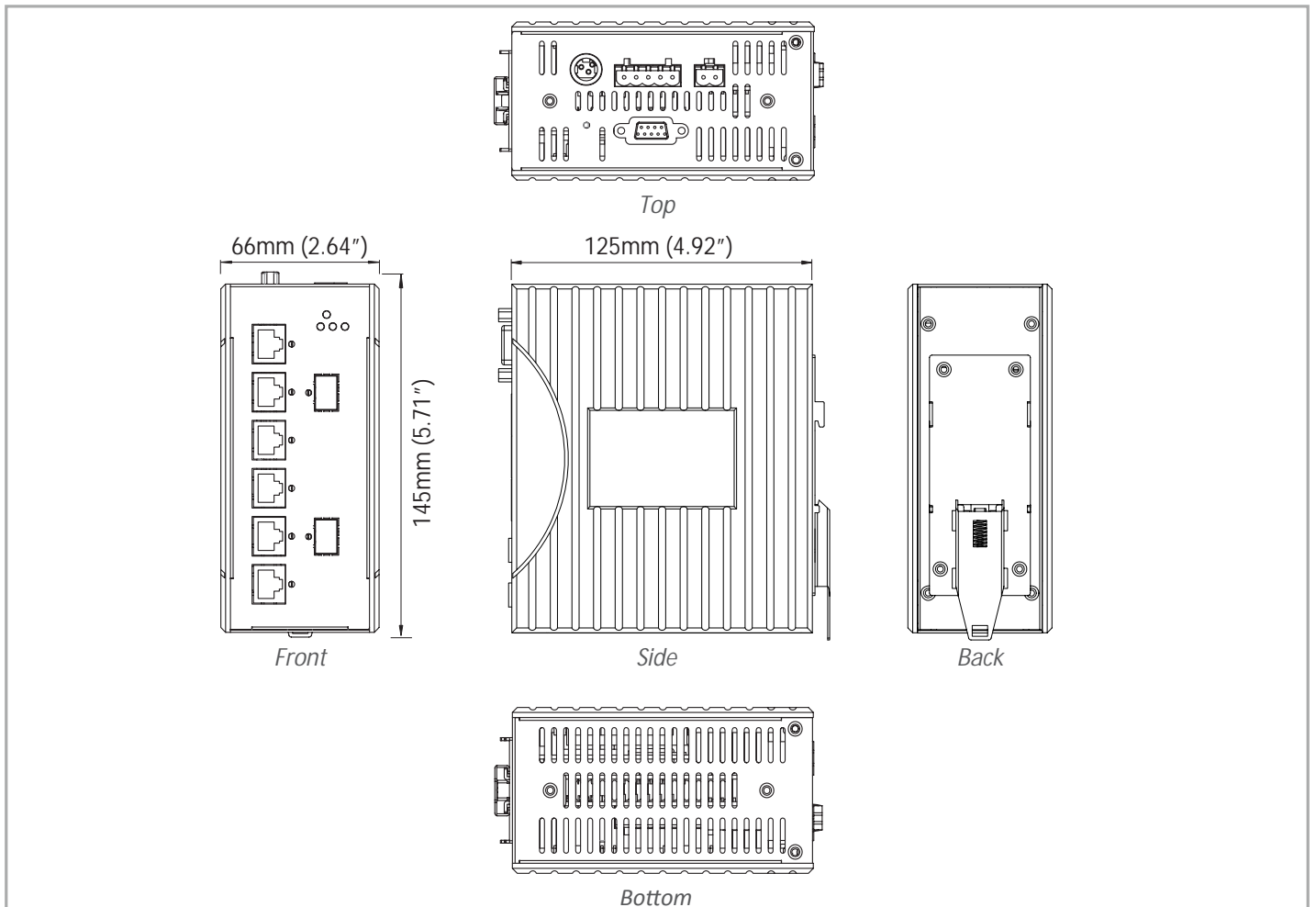

Ordering Information

Model

EX70980-00B	8-Port 10/100/1000BASE-TX Managed Hardened Ethernet Switch
EX70971-0VB	7-Port 10/100/1000BASE-TX + 1-Port Gigabit SFP Hardened Managed Ethernet Switch
EX70962-0VB	6-Port 10/100/1000BASE-TX + 2-Port Gigabit SFP Hardened Managed Ethernet Switch
EX70962-0XB	6-Port 10/100/1000BASE-TX +2-Port Gigabit Fiber Hardened Managed Ethernet Switch

* DIN-Rail mounting kit included

Gigabit Port Options (X)

3	1000BASE-SX(SC) - 550m
4	1000BASE-SX (SC) - 2Km
5	1000BASE-SX (ST) - 550m
A	1000BASE-LX (SC) - 10Km
B	1000BASE-LX (SC) - 20Km
R	1000BASE-BX (SC) WDM-TX:1310nm/RX:1550nm - 20Km
S	1000BASE-BX (SC) WDM-TX:1550nm/RX:1310nm - 20Km

* More Gigabit options are also available upon request

Optional Accessories

DR-30-24	30W/1.5A DIN-Rail 24VDC Industrial Power Supply (for Terminal Block)
DR-60-24	60W/2.5A DIN-Rail 24VDC Industrial Power Supply (for Terminal Block)
DR-75-24	75W/3.2A DIN-Rail 24VDC Industrial Power Supply (for Terminal Block)
DR-120-24	120W/5A DIN-Rail 24VDC Industrial Power Supply (for Terminal Block)
41-136046-X	36W/3A 12VDC hardened power adapter with open wire in aluminum housing (for Terminal Block) (X) = 1: US, 2: EU, 3: UK, 4: AU, 5: JP, 6: SA
41-136044-X	36W/3A 12VDC hardened power adapter with latched DC Jack in aluminum housing (for DC Jack) (X) = 1: US, 2: EU, 3: UK, 4: AU, 5: JP, 6: SA

EX77000 Series

Hardened Managed 24-port 10/100BASE and 4-port Gigabit Ethernet Switch with SFP options

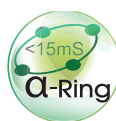

Overview

EtherWAN's EX77000 Series provides a Hardened Fully Managed 28-port switching platform combining high performance switching backbone with robust and secure management features required for mission critical and harsh environments where sustained connectivity is crucial.

The EX77000 Series is equipped with twenty-four 10/100BASE Fast Ethernet ports, in combination with up to four Gigabit, Fixed Fiber, or SFP Combo port options. Mountable on a 1U rack, the EX77000 Series is equipped with EtherWAN's Alpha-Ring self-healing technology, providing less than 15ms fault recovery time making it ideal for applications intolerant to interruption.

Users are able to access management features such as port security, IGMP snooping, VLANs, GARP protocols, LACP, and via web browser, Telnet, SNMP, RMON, TFTP, and RS-232 console interfaces.

EtherWAN — "When Connectivity is Crucial."

Spotlight

• Versatile Connectivity

- Provides flexibility of 24-port 10/100BASE-TX/FX/BX/SFP plus 4-port Gigabit-TX/SX/LX/BX/SFP

• Hardened Grade

- Wide operating temperature range for extreme environments
- Fanless and ruggedized housing
- High shock and electric noise immunity

• Secure Remote Access

- IEEE802.1x, ACL(Access Control List), and RADIUS support

Software Features

Management

- Interface
 - CLI, Telnet and Web Browser
 - SNMP v1/v2c/v3
- Firmware and configuration upgrade and backup via TFTP
- Supports DHCP Server/Client
- RMON (Remote monitoring)
- Port mirroring: TX/RX and both
- NTP (Network Time Protocol) time synchronization
- IEEE802.1ab LLDP (Link Layer Discovery Protocol)

Security

- MAC address filtering
- Enable/disable port
- Storm control (broadcast and multicast types)
- IEEE802.1x LAN access control
- Remote authentication through RADIUS
- SSH for CLI and Telnet security
- SSL for web security
- Multi-level user account/password against unauthorized configuration
- System log (remote/local)
- ACL

Quality of Service (QoS)

- Priority Queues: 4 queues per port
- Traffic classification based on IEEE802.1p CoS, DSCP, WRR (Weighted round robin) and strict mode
- Rate Limiting (Ingress/Egress)

Layer 2 Features

- Auto-negotiation for port speed and duplex mode
- Flow Control
 - IEEE802.3x full duplex mode
 - Back-Pressure half duplex mode
- Redundant Protocol
 - IEEE802.1D Spanning Tree Protocol (STP)
 - IEEE802.1w Rapid Spanning Tree Protocol (RSTP)
 - IEEE802.1s Multiple Spanning Tree Protocol (MSTP)
 - EtherWAN's Alpha-Ring with network fault recovery (<15ms)
- VLANs
 - Port-based VLANs
 - IEEE802.1Q Tag VLANs (128 groups, 4096 VID)
 - GVRP (GARP VLAN Registration Protocol)
 - GMRP (GARP Multicast Registration Protocol)
- Link Aggregation
 - Static Trunk (8 groups, support MAC base)
 - IEEE802.3ad Link Aggregation Control Protocol
- IGMP Snooping
 - IGMP snooping v1/v2/v3

Performance

- Switching Capability: 12.8Gbps
- Packet Buffer Size: 3M bit
- MAC Address Table: 8192

Hardware Specifications

Technology

Standards

- IEEE802.3 10BASE-T
- IEEE802.3u 100BASE-TX/100BASE-FX
- IEEE802.3ab 1000BASE-T
- IEEE802.3z 1000BASE-SX/1000BASE-LX
- IEEE802.3x Full duplex and flow control
- IEEE802.1p QoS
- IEEE802.1Q Tag VLANs
- IEEE802.1w RSTP
- IEEE802.1x Port-based Network Access Control

Forward and Filtering Rate

- 14,880pps for 10Mbps
- 148,810pps for 100Mbps
- 1,488,100pps for 1000Mbps

Packet Buffer Memory

- 3M bits

Processing Type

- Store-and-Forward
- Auto Negotiation
- Half-duplex back-pressure and IEEE802.3x full-duplex flow control
- Auto MDI/MDIX

Address Table Size

- 8192 MAC addresses

Power

Input

- (T): + / - 48VDC (36 - 75VDC) Internal Universal PSU
- (W): 88 - 370VDC and 90 - 264VAC Internal Universal PSU
- (C): 90 - 264VAC, 50 - 60Hz Internal Universal PSU

Power Consumption

- 42.7W Max.

Protection

- Overload current protection

Mechanical

Casing

- Metal Case
- IP30

Dimensions

- Single Power:
442mm (W) x 250mm (D) x 44.2mm (H)
(7.4" (W) x 9.8" (D) x 1.74" (H))
- Redundant Power:
442mm (W) x 375mm (D) x 44.2mm (H)
17.4" (W) x 14.7" (D) x 1.74" (H)

Weight

- 6.2Kg (13.7lbs)

Installation

- Rack mounting

Interface

Ethernet Port

- 10/100BASE-TX: 24, 20, 16, 12, 8, 4 or 0 port
- 100BASE-FX: 0, 4, 8, 12, 16, 20 or 24 ports
- 100BASE-SFP: 0 or 24 ports
- 10/100/1000BASE TX or 1000BASE SX/LX: 0, 2 or 4 ports
- Gigabit-SFP Combo: 0 or 4 ports

Console Port

- Port: One DB9 RS-232 port

LED Indicators

- Per Unit: Power
- Per Port: Link/Activity (Green)
- Per SFP port: Selected (Green)

Environment

Operating Temperature

- -40°C to 75°C (-40°F to 167°F)
- Tested @ -40°C to 85°C (-40°F to 185°F)

Storage Temperature

- -45°C to 85°C (-49°F to 185°F)

Ambient Relative Humidity

- 5% to 95% (non-condensing)

Regulatory Approvals

ISO

- Manufactured in an ISO9001 facility

EMI

FCC Part 15B, Class A

EN61000-6-4

EN55022

EN61000-3-2

EN61000-3-3

EMS

EN61000-6-2

- EN61000-4-2 (ESD Standards)
- EN61000-4-3 (RFI Standards)
- EN61000-4-4 (Burst Standards)
- EN61000-4-5 (Surge Standards)
- EN61000-4-6 (Induced RFI Standards)
- EN61000-4-8 (Magnetic Field Standards)

Environmental Test Compliance

IEC60068-2-6 Fc (Vibration Resistance)

IEC60068-2-27 Ea (Shock)

FED STD 101C Method 5007.1 (Free fall w/ package)

Industrial Compliance

NEMA TS2

Application Diagram

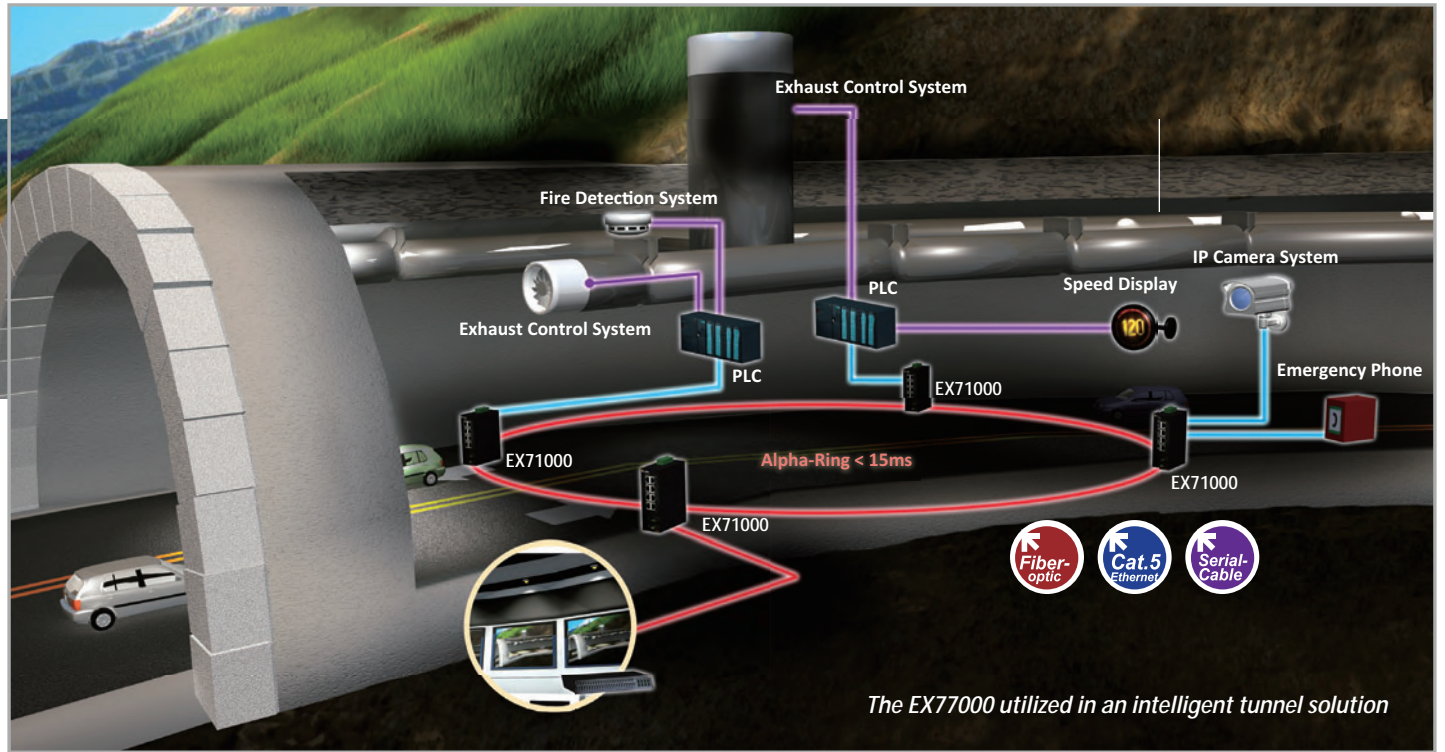

Dimensions

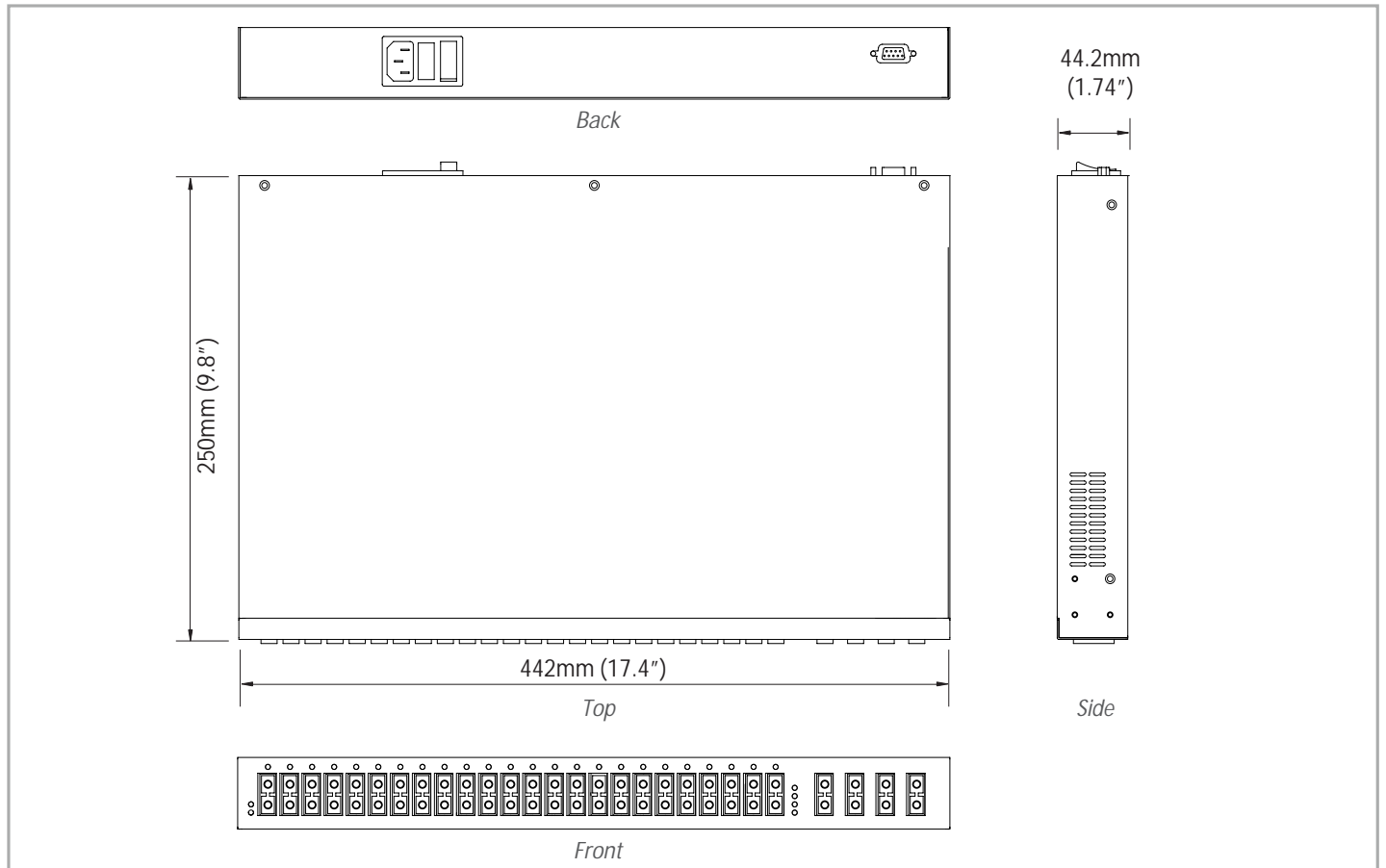

Ordering Information

Model

EX77604-0XYZ	24-port 10/100BASE-TX + 4-port Gigabit Managed Ethernet Switch
EX77424-WXYZ	16-port 10/100BASE-TX + 8-port 100BASE-FX + 4-port Gigabit Managed Ethernet Switch
EX77244-WXYZ	8-port 10/100BASE-TX + 16-port 100BASE-FX + 4-port Gigabit Managed Ethernet Switch
EX77064-WXYZ	24-port 100BASE-FX + 4-port Gigabit Managed Ethernet Switch
EX77064-V0VZ	24-port 100BASE-SFP + 4-port Gigabit SFP Combo Managed Ethernet Switch

* Rack mounting kit included

100FX Fiber Options (W)

1	Multi Mode (SC) - 2Km
2	Multi Mode (ST) - 2Km
6	Multi Mode (SC) WDM-TX:1310nm/RX:1550nm - 2Km
7	Multi Mode (SC) WDM-TX:1550nm/RX:1310nm - 2Km
8	Multi Mode (SC) WDM-TX:1310nm/RX:1550nm - 5Km
9	Multi Mode (SC) WDM-TX:1550nm/RX:1310nm - 5Km
A	Single Mode (SC) - 20Km
B	Single Mode (SC) - 40Km
F	Single Mode (FC) - 20Km
H	Single Mode (ST) - 20Km
P	Single Mode (SC) WDM-TX:1310nm/RX:1550nm - 20Km
Q	Single Mode (SC) WDM-TX:1550nm/RX:1310nm - 20Km
R	Single Mode (SC) WDM-TX:1310nm/RX:1550nm - 40Km
S	Single Mode (SC) WDM-TX:1550nm/RX:1310nm - 40Km
V	SFP

Numbers of fixed Gigabit Fiber (X)

0	None
1	One Gigabit Fiber Port
2	Two Gigabit Fiber Ports
3	Three Gigabit Fiber Ports
4	Four Gigabit Fiber Ports

Gigabit Port Options (Y)

1	10/100/1000BASE-TX
3	1000BASE-SX(SC) - 550m
4	1000BASE-SX (SC) - 2Km
A	1000BASE-LX (SC) - 10Km
B	1000BASE-LX (SC) - 20Km
R	1000BASE-BX (SC) WDM-TX:1310nm/RX:1550nm - 20Km
S	1000BASE-BX (SC) WDM-TX:1550nm/RX:1310nm - 20Km
V	4-port 1000 BASE SFP Combo with 10/100/1000BASE-TX

Ordering Information - continued

Power Input Interface (Z)

T	± 48VDC (Terminal Block)
W	88 - 370VDC and 90 - 264VAC (Terminal Block)
C	90 - 264VAC (AC Inlet)
TR	± 48VDC Redundant (Terminal Block)
WR	88 - 370VDC and 90 - 264VAC Redundant (Terminal Block)
CR	90 - 264VAC Redundant (AC Inlet)

EX87000 Series

IEC61850-3/IEEE1613 Hardened Managed 24-port 10/100BASE and 4-port Gigabit Ethernet Switch with SFP options



Overview

EtherWAN's EX87000 Series provides a Hardened Fully Managed 28-port switching platform combining high performance switching backbone with robust and secure management features required for mission critical and harsh environments where sustained connectivity is crucial.

The EX87000 Series is equipped with twenty-four 10/100BASE Fast Ethernet ports, in combination with up to four Gigabit, Fixed Fiber, or SFP Combo port options. Mountable on a 1U rack, the EX87000 Series is equipped with EtherWAN's Alpha-Ring self-healing technology, providing less than 15ms fault recovery time making it ideal for applications intolerant to interruption.

Users are able to access management features such as port security, IGMP snooping, VLANs, GARP protocols, LACP, and GOOSE messaging to name a few, via web browser, Telnet, SNMP, RMON, TFTP, and RS-232 console interfaces. With its hardened-grade specifications and IEC61850 & IEEE1613 certifications, the EX87000 Series is capable of operating under high EMI environments at the temperatures ranging from -40°C to 75°C, making it an ideal choice for harsh applications.

EtherWAN – "When Connectivity is Crucial."

Spotlight

• Versatile Connectivity

- Provides flexibility of 24-port 10/100BASE-TX/FX/BX/SFP plus 4-port Gigabit-TX/SX/LX/BX/SFP

• Hardened Grade

- Wide operating temperature range for extreme environments
- Fanless and ruggedized housing
- High shock and electric noise immunity

• KEMA-Certified

- IEC61850-3 and IEEE1613 performance tests conducted by KEMA

Software Features

Management

- Interface
 - CLI, Telnet and Web Browser
 - SNMP v1/v2c/v3
- Firmware and configuration upgrade and backup via TFTP
- Supports DHCP Server/Client
- RMON (Remote monitoring)
- Port mirroring: TX/RX and both
- NTP (Network Time Protocol) time synchronization
- IEEE802.1ab LLDP (Link Layer Discovery Protocol)

Security

- MAC address filtering
- Enable/disable port
- Storm control (broadcast and multicast types)
- IEEE802.1x LAN access control
- Remote authentication through RADIUS
- SSH for CLI and Telnet security
- SSL for web security
- ACL

Quality of Service (QoS)

- Priority Queues: 4 queues per port
- Traffic classification based on IEEE802.1p CoS, DSCP, WRR (Weighted round robin) and strict mode
- Rate Limiting (Ingress/Egress)

Layer 2 Features

- Auto-negotiation for port speed and duplex mode
- Flow Control
 - IEEE802.3x full duplex mode
 - Back-Pressure half duplex mode
- Redundant Protocol
 - IEEE802.1D Spanning Tree Protocol (STP)
 - IEEE802.1w Rapid Spanning Tree Protocol (RSTP)
 - IEEE802.1s Multiple Spanning Tree Protocol (MSTP)
 - EtherWAN's α -Ring network fault recovery (<15ms) and α -Chain
- VLANs
 - Port-based VLANs
 - IEEE802.1Q Tag VLANs (128 groups, 4096 VID)
 - GVRP (GARP VLAN Registration Protocol)
 - GMRP (GARP Multicast Registration Protocol)
- Link Aggregation
 - Static Trunk (8 groups, support MAC base)
 - IEEE802.3ad Link Aggregation Control Protocol
- IGMP Snooping
 - IGMP snooping v1/v2/v3

Performance

- Switching Capability: 12.8Gbps
- Packet Buffer Size: 3M bits
- MAC Address Table: 4K

Hardware Specifications

Technology

Standards

- IEEE802.3 10BASE-T
- IEEE802.3u 100BASE-TX/100BASE-FX
- IEEE802.3ab 1000BASE-T
- IEEE802.3z 1000BASE-SX/1000BASE-LX
- IEEE802.3x Full duplex and flow control
- IEEE802.1p QoS
- IEEE802.1Q Tag VLANs
- IEEE802.1w RSTP
- IEEE802.1x Port-based Network Access Control

Forward and Filtering Rate

- 14,880pps for 10Mbps
- 148,810pps for 100Mbps
- 1,488,100pps for 1000Mbps

Packet Buffer Memory

- 3M bits

Processing Type

- Store-and-Forward
- Auto-Negotiation
- Half-duplex back-pressure and IEEE802.3x full-duplex flow control
- Auto MDI/MDIX

Address Table Size

- 8192 MAC addresses

Power

Input

- (T): + / - 48VDC (36 - 75VDC) Internal Universal PSU
- (W): 88 - 370VDC and 90 - 264VAC Internal Universal PSU
- (C): 90 - 264VAC, 50 - 60Hz Internal Universal PSU

Power Consumption

- 42.7W Max.

Protection

- Overload current protection

Mechanical

Casing

- Metal Case
- IP30

Dimensions

- Single Power:
442mm (W) x 284mm (D) x 44.2mm (H);
17.4" (W) x 11.1" (D) x 1.74" (H)
- Redundant Power:
442mm (W) x 375mm (D) x 44.2mm (H);
17.4"(W) x 14.7" (D) x 1.74"(H)

Weight

- Single Power: 5.1Kg (11.2lbs.)
- Redundant Power: 6.2Kg (13.7lbs.)

Installation

- Rack mounting

Interface

Ethernet Port

- 10/100BASE-TX: 24, 16, 8 or 0 port
- 100BASE-FX: 0, 4, 8, 12, 16, 20 or 24 ports
- Gigabit: 0, 2 or 4 ports

Console Port

- Port: One DB9 RS-232 port

LED Indicators

- Per Unit: Power
- Per Port: Link/Activity (Green)
- Per SFP slot: Selected (Green)

Environment

Operating Temperature

- -40°C to 75°C (-40°F to 167°F)
- Tested @ -40°C to 85°C (-40°F to 185°F)

Storage Temperature

- -45°C to 85°C (-49°F to 185°F)

Ambient Relative Humidity

- 5% to 95% (non-condensing)

Regulatory Approvals

ISO

- Manufactured in an ISO9001 facility

EMI

FCC Part 15B, Class A

EN61000-6-4

EMS

EN61000-6-2

- EN61000-4-2 (ESD Standards)
- EN61000-4-3 (Radiated RFI Standards)
- EN61000-4-4 (Burst Standards)
- EN61000-4-5 (Surge Standards)
- EN61000-4-6 (Induced RFI Standards)
- EN61000-4-8 (Magnetic Field Standards)
- IEC61000-4-10 (Oscillatory wave magnetic field test)
- IEC61000-4-16 (Power frequency immunity test)
- IEC61000-4-18 (Oscillatory wave immunity test)

Environmental Test Compliance

IEC60068-2-6 Fc (Vibration Resistance)

IEC60068-2-27 Ea (Shock)

FED STD 101C Method 5007.1 (Free fall w/ package)

Industrial Compliance

IEC61850-3 / IEEE1613

EN50121-4

IEC60870-2-1

Application Diagram

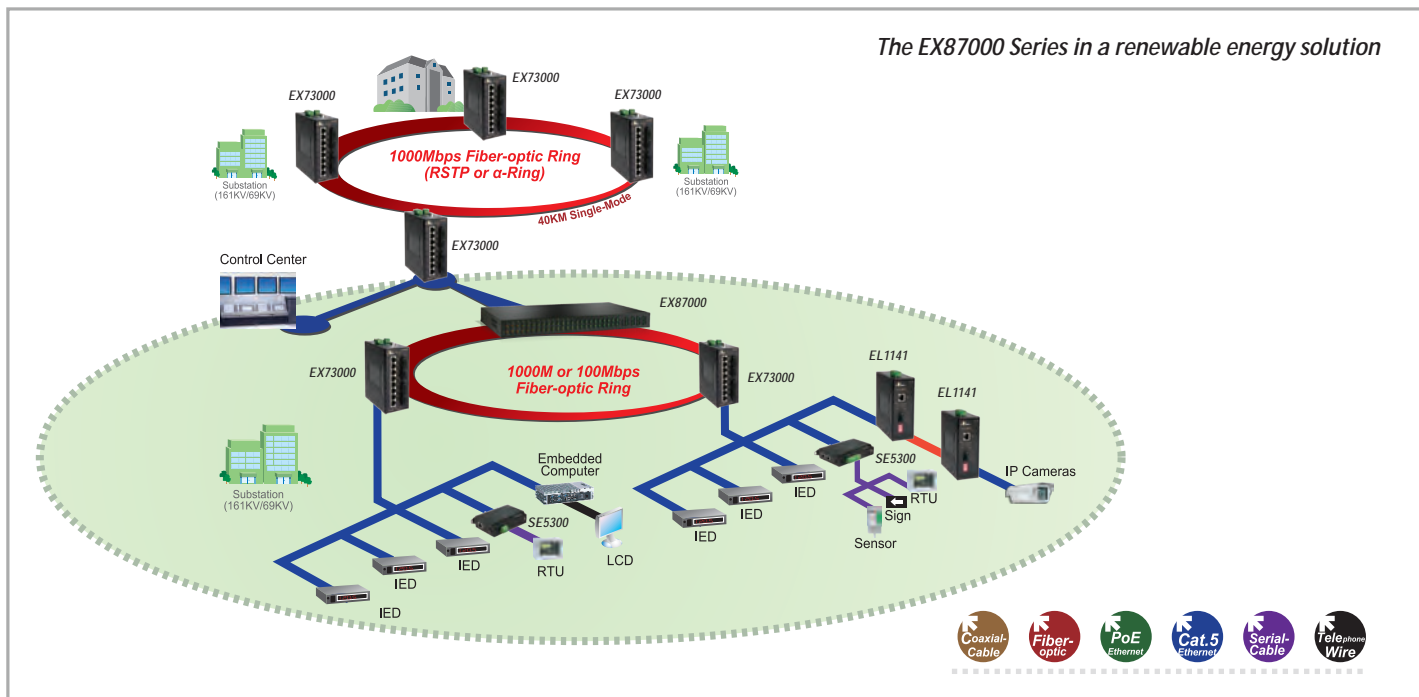

Dimension

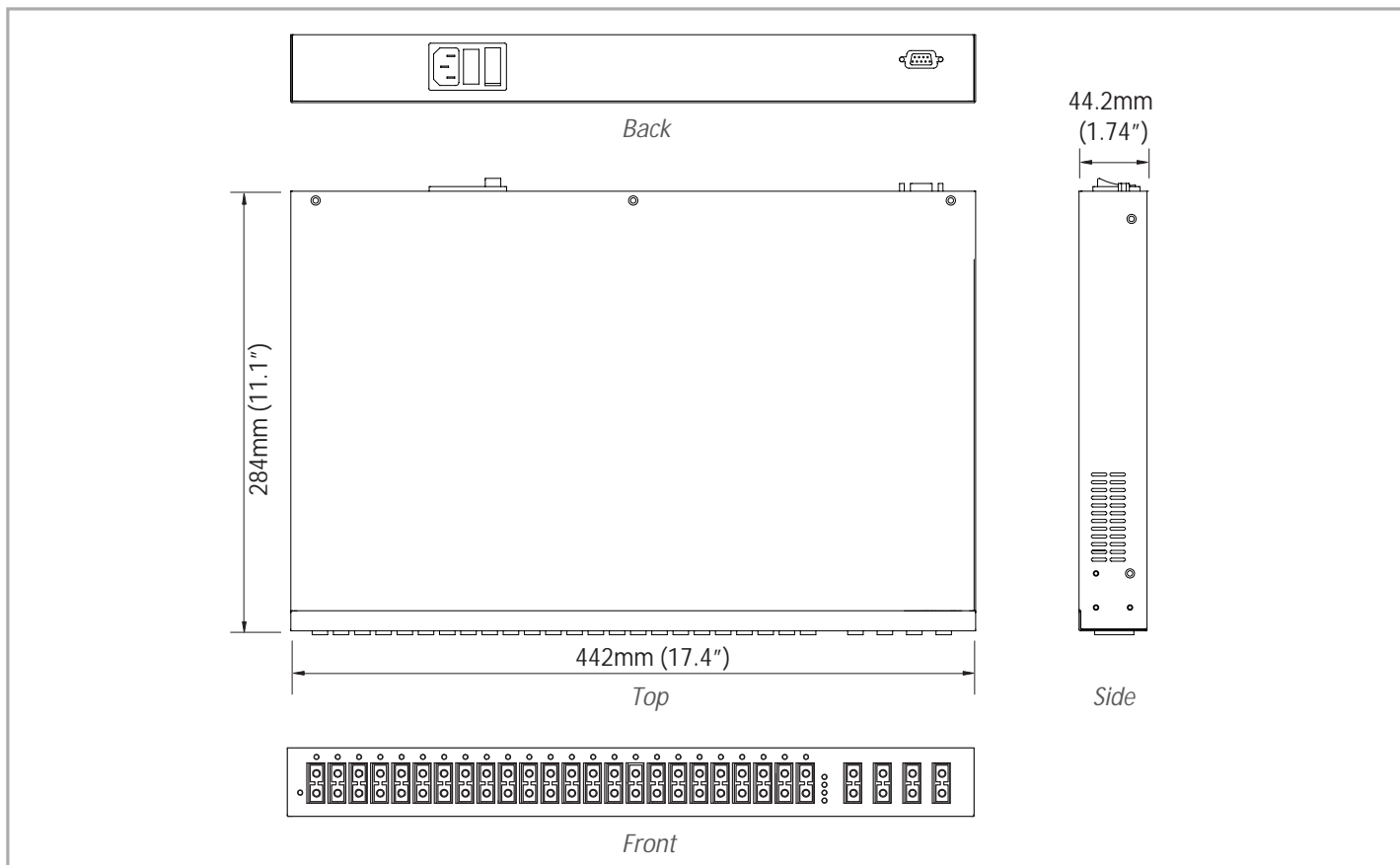

Ordering Information

Model

EX87604-0XYZ	Hardened Managed 24-port 10/100BASE-TX + 4-port Gigabit Ethernet Switch
EX87424-WXYZ	Hardened Managed 16-port 10/100BASE-TX + 8-port 100BASE-FX + 4-port Gigabit Ethernet Switch
EX87412-WXYZ	Hardened Managed 16-port 10/100BASE-TX + 4-port 100BASE-FX + 4-port Gigabit Ethernet Switch
EX87244-WXYZ	Hardened Managed 8-port 10/100BASE-TX + 16-port 100BASE-FX + 4-port Gigabit Ethernet Switch
EX87064-WXYZ	Hardened Managed 24-port 100BASE-FX + 4-port Gigabit Ethernet Switch
EX87064-V0VZ	Hardened Managed 24-port 100BASE-SFP + 4-port Gigabit SFP Combo Ethernet Switch

* Rack mounting kit included

100FX Fiber Options (W)

1	Multi Mode (SC) - 2Km
2	Multi Mode (ST) - 2Km
6	Multi Mode (SC) WDM-TX:1310nm/RX:1550nm - 2Km
7	Multi Mode (SC) WDM-TX:1550nm/RX:1310nm - 2Km
8	Multi Mode (SC) WDM-TX:1310nm/RX:1550nm - 5Km
9	Multi Mode (SC) WDM-TX:1550nm/RX:1310nm - 5Km
A	Single Mode (SC) - 20Km
B	Single Mode (SC) - 40Km
F	Single Mode (FC) - 20Km
H	Single Mode (ST) - 20Km
P	Single Mode (SC) WDM-TX:1310nm/RX:1550nm - 20Km
Q	Single Mode (SC) WDM-TX:1550nm/RX:1310nm - 20Km
R	Single Mode (SC) WDM-TX:1310nm/RX:1550nm - 40Km
S	Single Mode (SC) WDM-TX:1550nm/RX:1310nm - 40Km
V	100BASE SFP

*More 100FX Fiber options also available upon request.

Numbers of fixed Gigabit Fiber (X)

0	None
1	One Gigabit Fiber Port
2	Two Gigabit Fiber Ports
3	Three Gigabit Fiber Ports
4	Four Gigabit Fiber Ports

Gigabit Port Options (Y)

1	10/100/1000BASE-TX
3	1000BASE-SX(SC) - 550m
4	1000BASE-SX (SC) - 2Km
5	1000BASE-SX (ST) - 550m
A	1000BASE-LX (SC) - 10Km
B	1000BASE-LX (SC) - 20Km
R	1000BASE-BX (SC) WDM-TX:1310nm/RX:1550nm - 20Km
S	1000BASE-BX (SC) WDM-TX:1550nm/RX:1310nm - 20Km
V	4-port 1000BASE SFP Combo with 10/100/1000BASE-TX

* More Gigabit options also available upon request

Ordering Information - continued

Power Input Interface (Z)

T	± 48VDC (Terminal Block)
W	88 - 370VDC and 90 - 264VAC (Terminal Block)
C	90 - 264VAC (AC Inlet)
TR	± 48VDC Redundant (Terminal Block)
WR	88 - 370VDC and 90 - 264VAC Redundant (Terminal Block)
CR	90 - 264VAC Redundant (AC Inlet)

EX89000 Series

IEC61850-3/IEEE1613 Modulized Hardened Managed 24-port 10/100BASE and 4-port Gigabit Ethernet Switch with SFP options

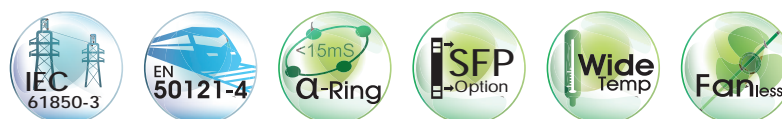

Overview

EtherWAN's EX89000 Series provides a Hardened Fully Managed 28-port switching platform combining high performance switching backbone with robust and secure management features required for mission critical and harsh environments where sustained connectivity is crucial.

Highly modulized, the EX89000 switch supports up to 28 electrical and/or optical interfaces with data transfer rates of 10/100 Mbits and up to four Gigabit, Fixed Fiber, or SFP Combo port options. Mountable on a 1U rack, the EX89000 Series is equipped with EtherWAN's Alpha-Ring self-healing technology, providing less than 15ms fault recovery time making it ideal for applications intolerant to interruption.

Users are able to access management features such as port security, IGMP snooping, VLANs, GARP protocols, LACP, and GOOSE messaging to name a few, via web browser, Telnet, SNMP, RMON, TFTP, and RS-232 console interfaces. With its hardened-grade specifications and IEC61850 & IEEE1613 certifications, the EX89000 Series is capable of operating under high EMI environments at the temperatures ranging from -40°C to 75°C, making it an ideal choice for harsh applications.

EtherWAN—"When Connectivity is Crucial."

Spotlight

- **Versatile Connectivity**
 - Modulized 24-port 10/100BASE-TX/FX/BX and 4-port Gigabit-TX/SX/LX/BX/SFP
- **Hardened Grade**
 - Wide operating temperature range for extreme environments
 - Fanless and ruggedized housing
 - High shock and electric noise immunity
- **IEC61850-3 & IEEE1613 Certified**
 - Meets the standards for operating in power substation zones

Software Features

Management

- Interface
 - CLI, Telnet and Web Browser
 - SNMP v1/v2c/v3
- Firmware and configuration upgrade and backup via TFTP
- Supports DHCP Server/Client
- RMON (Remote monitoring)
- Port mirroring: TX/RX and both
- NTP (Network Time Protocol) time synchronization

Security

- MAC Address by port security
- Enable/disable port
- Storm control (broadcast and multicast types)
- IEEE802.1x LAN access control
- Remote authentication through RADIUS

Quality of Service (QoS)

- Priority Queues: 4 queues per port
- Traffic classification based on IEEE802.1p CoS, DSCP, WRR (Weighted round robin) and strict mode
- Rate Limiting (Ingress/Egress)

Layer 2 Features

- Auto-negotiation for port speed and duplex mode
- Flow Control
 - IEEE802.3x full duplex mode
 - Back-Pressure half duplex mode
- Redundant Protocol
 - IEEE802.1D Spanning Tree Protocol (STP)
 - IEEE802.1w Rapid Spanning Tree Protocol (RSTP)
 - IEEE802.1s Multiple Spanning Tree Protocol (MSTP)
 - Supports EtherWAN's Alpha-Ring topology for less than 15ms fault recovery time
- VLANs
 - Port-based VLANs
 - IEEE802.1Q Tag VLANs (128 groups, 4096 VID)
 - GVRP (GARP VLAN Registration Protocol)
 - GMRP (GARP Multicast Registration Protocol)
- Link Aggregation
 - Static Trunk (8 groups, support MAC base)
 - IEEE802.3ad Link Aggregation Control Protocol
- IGMP Snooping
 - IGMP snooping v1/v2/v3

Performance

- Switching Capability: 12.8Gbps
- Packet Buffer Size: 3M bits
- MAC Address Table: 8192

Hardware Specifications

Technology

Standards

- IEEE802.3 10BASE-T
- IEEE802.3u 100BASE-TX/100BASE-FX
- IEEE802.3ab 1000BASE-T
- IEEE802.3z 1000BASE-SX/1000BASE-LX
- IEEE802.3x Full duplex and flow control
- IEEE802.1p QoS
- IEEE802.1Q Tag VLANs
- IEEE802.1w RSTP
- IEEE802.1x Port-based Network Access Control

Forward and Filtering Rate

- 14,880pps for 10Mbps
- 148,810pps for 100Mbps
- 1,488,100pps for 1000Mbps

Packet Buffer Memory

- 3M bits

Processing Type

- Store-and-Forward
- Auto Negotiation
- Half-duplex back-pressure and IEEE802.3x full-duplex flow control
- Auto MDI/MDIX

Address Table Size

- 8192 MAC addresses

Power

Input

- (T) : ±48VDC (36–75VDC) Internal Universal PSU
- (W) : 88–370VDC and 90–264VAC Internal Universal PSU
- (C) : 90–264VAC, 50–60Hz Internal Universal PSU
- (TR) : ±48VDC Redundant (Terminal Block)
- (WR) : 88–370VDC and 90-264VAC Redundant (Terminal Block)
- (CR): 90–264VAC Redundant (AC Inlet)

Power Consumption

- 42.7W Max.

Protection

- Overload Current Protection

Mechanical

Casing

- Metal Case
- IP30

Dimensions

- Single Power:
442mm (W) x 343mm (D) x 44.2mm (H)
(17.4" (W) x 13.5"(D) x 1.74" (H))
- Redundant Power:
442mm (W) x 404mm (D) x 44.2mm (H)
(17.4" (W) x 15.9"(D) x 1.74" (H))

Weight

- Single Power: 4.5Kg (9.9lbs.)
- Redundant Power: 4.6 kg (10.1 lbs.)

Installation

- Rack mounting

Interface

Ethernet Port

- 10/100BASE-TX: 24, 16, 8 or 0 port
- 100BASE-FX: 0 to 18 ports
- Gigabit: 0, 2 or 4 ports

Console Port

- Port: One DB9 RS-232 port

LED Indicators

- Per Unit: Power
- Per Port: Link/Activity (Green)
- Per SFP slot: Selected/Unselected (Green)

Environment

Operating Temperature

- -40°C to 75°C (-40°F to 167°F)
- Tested @ -40°C to 85°C (-40°F to 185°F)

Storage Temperature

- -45°C to 85°C (-49°F to 185°F)

Ambient Relative Humidity

- 5% to 95% (non-condensing)

Regulatory Approvals

ISO

- Manufactured in an ISO9001 facility

EMI

FCC Part 15B, Class A

EN61000-6-4

EN55022

EN61000-3-2

EN61000-3-3

EMS

EN61000-6-2

- EN61000-4-2 (ESD Standards)
- EN61000-4-3 (Radiated RFI Standards)
- EN61000-4-4 (Burst Standards)
- EN61000-4-5 (Surge Standards)
- EN61000-4-6 (Induced RFI Standards)
- EN61000-4-8 (Magnetic Field Standards)
- IEC61000-4-10 (Oscillatory wave magnetic field test)
- IEC61000-4-16 (Power frequency immunity test)
- IEC61000-4-18 (Oscillatory wave immunity test)

Environmental Test Compliance

IEC60068-2-6 Fc (Vibration Resistance)

IEC60068-2-27 Ea (Shock)

FED STD 101C Method 5007.1 (Free fall w/ package)

Industrial Compliance

IEEE61850-3 / IEEE1613

EN50121-4

Ordering Information

Model

EX89000-00Z	Rack mount chassis with integrated power supply for four M89000 modules
-------------	---

* Rack mounting kit included

Modules for EX89000 Series

Model	Description	Slot 1	Slot 2	Slot 3	Slot 4
M89800-000	8-Port 10/100BASE TX	✓	✓	✓	
M89620-W00	6-Port 10/100BASE TX + 2-Port 100BASE FX	✓	✓	✓	
M89420-W00	4-Port 10/100BASE TX + 2-Port 100BASE FX	✓	✓	✓	
M89060-W00	6-Port 10/100BASE FX	✓	✓	✓	
M89240-W00	2-Port 10/100BASE TX + 4-Port 100BASE FX	✓	✓	✓	
M89440-W00	4-Port 10/100BASE TX + 4-Port 100BASE FX	✓	✓	✓	
M89004-0XY	4-Port Gigabit				✓

100FX Fiber Options (W)

1	Multi Mode (SC) - 2Km
2	Multi Mode (ST) - 2Km
6	Multi Mode (SC) WDM-TX:1310nm/RX:1550nm - 2Km
7	Multi Mode (SC) WDM-TX:1550nm/RX:1310nm - 2Km
8	Multi Mode (SC) WDM-TX:1310nm/RX:1550nm - 5Km
9	Multi Mode (SC) WDM-TX:1550nm/RX:1310nm - 5Km
A	Single Mode (SC) - 20Km
B	Single Mode (SC) - 40Km
F	Single Mode (FC) - 20Km
H	Single Mode (ST) - 20Km
P	Single Mode (SC) WDM-TX:1310nm/RX:1550nm - 20Km
Q	Single Mode (SC) WDM-TX:1550nm/RX:1310nm - 20Km
R	Single Mode (SC) WDM-TX:1310nm/RX:1550nm - 40Km
S	Single Mode (SC) WDM-TX:1550nm/RX:1310nm - 40Km

*More 100FX Fiber options also available upon request.

Numbers of fixed Gigabit Fiber (X)

0	None
4	Four Gigabit Fiber Ports

Gigabit Port Options (Y)

1	10/100/1000BASE-TX
3	1000BASE-SX (SC) - 550m
4	1000BASE-SX (SC) - 2Km
5	1000BASE-SX (ST) - 550m
A	1000BASE-LX (SC) - 10Km
B	1000BASE-LX (SC) - 20Km
R	1000BASE-BX (SC) WDM-TX:1310nm/RX: 1550nm - 20Km
S	1000BASE-BX (SC) WDM-TX:1550nm/RX: 1310nm - 20Km
V	4-port 1000BASE SFP Combo with 10/100/1000BASE-TX

* More Gigabit options also available upon request.

Power Input Interface (Z)

T	±48VDC (Terminal Block)
W	88 - 370VDC and 90 - 264VAC (Terminal Block)
C	90 - 264VAC Redundant (AC Inlet)
TR	±48VDC Redundant (Terminal Block)
WR	88 - 370VDC and 90 - 264VAC Redundant
CR	90 - 264VAC Redundant (AC Inlet)

EX75000 Series

Hardened Managed 24-port 10/100BASE-TX + 4-port Gigabit Ethernet PoE Switch



Overview

EtherWAN's EX75000 Series provides a hardened 28-port switching platform supporting IEEE802.3at Power over Ethernet, high performance switching with robust management features required for mission-critical and harsh environments where sustained connectivity is crucial.

The EX75000 Series is equipped with 24 10/100BASE-TX PoE ports, in combination with two Gigabit PoE ports and two Gigabit SX/LX/BX/WDM Fiber ports with SFP options.

The IEEE802.3at PoE ports provide up to 30W/port with a total power budget of 420W, making the switch truly versatile for connecting with PoE Powered Devices (PD) with different bandwidth and power consumption requirements such as outdoor PTZ dome cameras, wireless access points, and way-side communication devices.

1U rack mountable, the EX75000 Series is equipped with EtherWAN's Alpha-Ring self-healing ring technology providing less than 15ms fault recovery time. Users are able to access management features such as port security, IGMP snooping, port-based VLAN, GARP protocols, Link Aggregation, via web browser, Telnet, SSH, SNMP, RMON, TFTP, and RS-232 console interfaces. With the hardened specifications, the EX75000 Series is designed to operate at -40°C to 75°C in harsh environments, where high ESD, shock, and vibration may be present.

EtherWAN — "When Connectivity is Crucial."

Spotlight

• High-Density PoE Switch

- Up to 26 IEEE802.3at PoE ports
- 4 Gigabit (SX/LX/SFP) ports for high-bandwidth communication

• Intelligent Data and Power Management

- Optimize network performance with QoS, VLAN and PoE scheduling, etc.
- Network redundancy secured with EtherWAN's Alpha-Ring network fault recovery time < 15ms

• Secure Remote Access

- IEEE802.1x, ACL (Access Control List), and RADIUS support

Software Features

Management

- Interface
 - CLI, Telnet and Web Browser
 - SNMP v1/v2c/v3
- Firmware and configuration upgrade and backup via TFTP
- Supports DHCP Server/Client
- RMON (Remote monitoring)
- Port mirroring: TX/RX and both
- SFP transceivers support Digital Diagnostics Monitoring (DDM)
- NTP (Network Time Protocol) time synchronization
- IEEE802.1ab LLDP (Link Layer Discovery Protocol)

Security

- MAC address filtering
- Enable/disable port
- Storm control (broadcast and multicast types)
- IEEE802.1x LAN access control
- Remote authentication through RADIUS
- SSH for CLI and Telnet security
- SSL for web security
- ACL

Quality of Service (QoS)

- Priority Queues: 4 queues per port
- Traffic classification based on IEEE802.1p CoS, DSCP, WRR (Weighted round robin) and strict mode
- Rate Limiting (Ingress/Egress)

Layer 2 Features

- Auto-negotiation for port speed and duplex mode
- Flow Control
 - IEEE802.3x full duplex mode
 - Back-Pressure half duplex mode
- Redundant Protocol
 - IEEE802.1D Spanning Tree Protocol (STP)
 - IEEE802.1w Rapid Spanning Tree Protocol (RSTP)
 - IEEE802.1s Multiple Spanning Tree Protocol (MSTP)
 - EtherWAN's Alpha-Ring with network fault recovery (<15ms)
- VLANs
 - Port-based VLANs
 - IEEE802.1Q Tag VLANs (128 groups, 4096 VID)
 - GVRP (GARP VLAN Registration Protocol)
 - GMRP (GARP Multicast Registration Protocol)
- Link Aggregation
 - Static Trunk (8 groups, support MAC base)
 - IEEE802.3ad Link Aggregation Control Protocol
- IGMP Snooping
 - IGMP snooping v1/v2/v3

Performance

- Switching Capability: 12.8Gbps
- Packet Buffer Size: 3M bits
- MAC Address Table: 8K
- Jumbo frame: 2048 bytes

Hardware Specifications

Technology

Standards

- IEEE802.3 10BASE-T
- IEEE802.3u 100BASE-TX/100BASE-FX
- IEEE802.3ab 1000BASE-T
- IEEE802.3z 1000BASE-SX/1000BASE-LX
- IEEE802.3x Full duplex and flow control
- IEEE802.1p QoS
- IEEE802.1Q Tag VLANs
- IEEE802.1w RSTP
- IEEE802.1x Port-based Network Access Control
- IEEE802.1s MSTP
- IEEE802.3ad LACP
- IEEE802.3af/at Power over Ethernet (PoE)

Forward and Filtering Rate

- 14,880pps for 10Mbps
- 148,810pps for 100Mbps
- 1,488,100pps for 1000Mbps

Packet Buffer Memory

- 3M bits

Processing Type

- Store-and-Forward
- Auto Negotiation
- Half-duplex back-pressure and IEEE802.3x full-duplex flow control
- Auto MDI/MDIX

Address Table Size

- 8192 MAC addresses

Power

Input Voltage

- Terminal Block: 55 (48 to 57VDC)

Power Consumption

- Max. 30W (without PoE)
- PoE power budget: 420W (depends on power input)
 - Port 01 to Port 08, 10/100 PoE ports: 120W
 - Port 09 to Port 16, 10/100 PoE ports: 120W
 - Port 17 to Port 24, 10/100 PoE ports: 120W
 - Port 25 to Port 26, 10/100/1000 PoE ports: 60W

Protection

- Overload current protection

Mechanical

Casing

- Metal Case
- IP30

Dimensions

- 442mm (W) x 343mm (D) x 44.2mm (H)
(17.4" (W) x 13.5" (D) x 1.74" (H))

Weight

- 5.15Kg (11.35lbs.)

Installation

- Rack mounting

Interface

Ethernet Port

- 10/100BASE-TX: 24 ports
- Gigabit: 4 ports

Console Port

- Port: One DB9 RS-232 port

LED Indicators

- Per Unit: Power (Green), Alarm (Red)
- Per Port: Link/Activity (Green)

Environment

Operating Temperature

- -40°C to 75°C (-40°F to 167°F)
Tested @ -40°C to 85°C (-40°F to 185°F)

Storage Temperature

- -45°C to 85°C (-49°F to 185°F)

Ambient Relative Humidity

- 5% to 95% (non-condensing)

Regulatory Approvals

ISO

- Manufactured in an ISO9001 facility

EMI

FCC Part 15B, Class A

VCCI Class A

EN61000-6-4

EN55022

EMS

EN61000-6-2

- EN61000-4-2 (ESD Standards)
- EN61000-4-3 (RFI Standards)
- EN61000-4-4 (Burst Standards)
- EN61000-4-5 (Surge Standards)
- EN61000-4-6 (Induced RFI Standards)
- EN61000-4-8 (Magnetic Field Standards)

Environmental Test Compliance

IEC60068-2-6 Fc (Vibration)

IEC60068-2-27 Ea (Shock)

IEC60068-2-32 Ed (Free fall)

Application Diagram

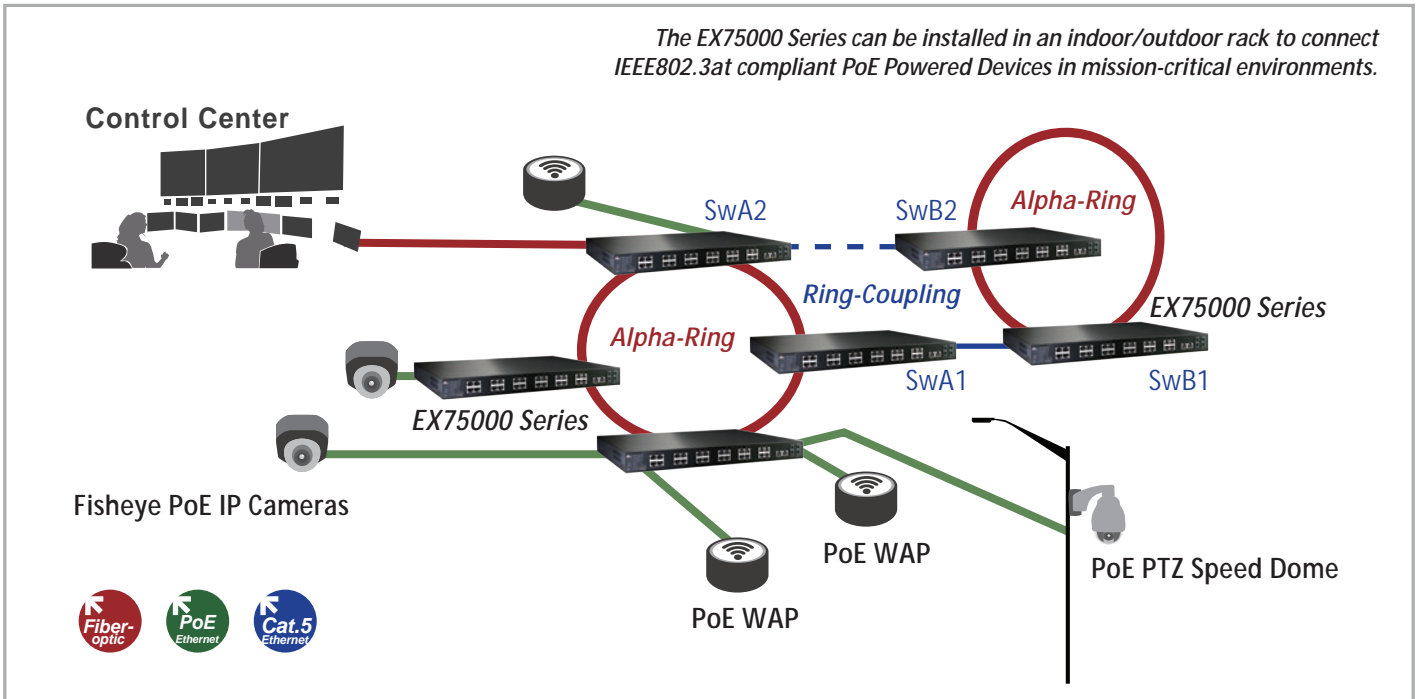

Dimensions

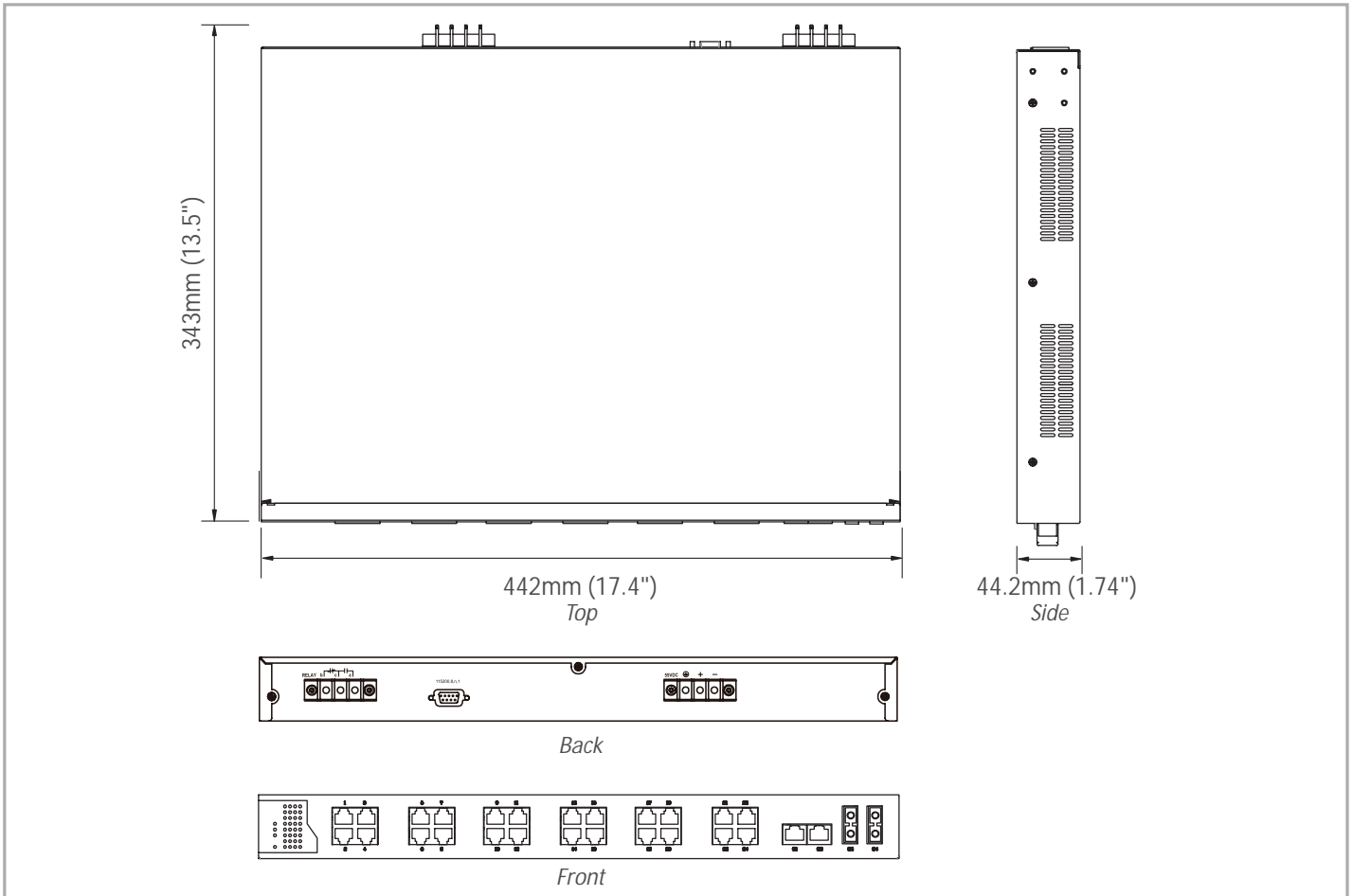

Ordering Information

Model

EX75604-0XYGT	24-port 10/100BASE-TX PoE + 2-port 10/100/1000BASE-T PoE + 2-port 1000BASE-T/SX/LX Hardened Managed Ethernet Switch
EX75604-04VGT	24-port 10/100BASE-TX PoE + 4-port 1000BASE SFP Hardened Managed Ethernet Switch

* Rack mounting kit included

Number of Fixed Gigabit Fibers (X)

0	None
2	Two Gigabit Fiber ports
4	Four Gigabit Fiber ports

Gigabit Port Options (Y)

1	10/100/1000BASE-TX
3	1000BASE-SX(SC) - 550m
4	1000BASE-SX (SC) - 2Km
A	1000BASE-LX (SC) - 10Km
B	1000BASE-LX (SC) - 20Km
R	1000BASE-BX (SC) WDM-TX:1310nm/RX:1550nm - 20Km
S	1000BASE-BX (SC) WDM-TX:1550nm/RX:1310nm - 20Km
V	1000BASE SFP (DDM)

Optional Accessories

SDR-480-48	480W/10A DIN-Rail Industrial Power Supply (for terminal block)
------------	--

EX76000 Series

Hardened Managed 16-port 10/100BASE PoE with 2-port Gigabit combo Ethernet Switch



Overview

EtherWAN's EX76000 Series provides a hardened 18-port switching platform supporting IEEE802.3af/at Power over Ethernet, high performance switching with robust management features required for mission-critical and harsh environments where sustained connectivity is crucial.

The EX76000 Series is equipped with 16 10/100BASE-TX PoE ports, in combination with two Gigabit SX/LX/BX/WDM combo port options. The IEEE802.3af/at PoE ports provide up to 15.4W/30W per port with a total power budget of 246W/480W, making the switch truly versatile for connecting with PoE Powered Devices (PD) with different bandwidth and power consumption requirements such as; outdoor PTZ dome cameras, wireless access points, and way-side communication devices.

1U rack mountable, the EX76000 Series is equipped with EtherWAN's Alpha-Ring self-healing ring technology providing less than 15ms fault recovery time. Users are able to access management features such as port security, IGMP snooping, port-based VLAN, GARP protocols, link aggregation, via web browser, telnet, SSH, SNMP, RMON, TFTP, and RS-232 console interfaces. With the hardened specifications, the EX76000 Series is designed to operate at -40°C to 75°C in harsh environments, where high ESD, shock, and vibration may be present.

EtherWAN – "When Connectivity is Crucial."

Spotlight

• PoE Connectivity

- Sixteen 10/100BASE IEEE802.3af/at Power over Ethernet ports
- Two Gigabit-SX/LX/BX combo ports

• Hardened Grade

- Wide operating temperature range from -40°C to 75°C (-40°F to 167°F) for extreme environments
- Fanless and ruggedized housing
- High shock and electric noise immunity
- Complies with UL508 safety requirements for industrial control devices

Software Features

Management

- Interface
 - CLI, Telnet and Web Browser
 - SNMP v1/v2c/v3
- Firmware and configuration upgrade and backup via TFTP
- Supports DHCP Server/Client
- RMON (Remote monitoring): group 1, 2, 3, 9
- Port mirroring: TX/RX and both
- NTP (Network Time Protocol) time synchronization
- IEEE802.1ab LLDP (Link Layer Discovery Protocol)

Security

- MAC address filtering
- Enable/disable port
- Storm control (broadcast and multicast types)
- IEEE802.1x LAN access control
- Remote authentication through RADIUS
- SSH for CLI and Telnet security
- SSL for web security
- Multi-level user account/password against unauthorized configuration
- System log (remote/local)

Quality of Service (QoS)

- Priority Queues: 4 queues per port
- Traffic classification based on IEEE802.1p CoS, DSCP, WRR (Weighted round robin) and strict mode
- Rate Limiting (Ingress/Egress)

Layer 2 Features

- Auto-negotiation for port speed and duplex mode
- Flow Control
 - IEEE802.3x full duplex mode
 - Back-Pressure half duplex mode
- Redundant Protocol
 - IEEE802.1D Spanning Tree Protocol (STP)
 - IEEE802.1w Rapid Spanning Tree Protocol (RSTP)
 - IEEE802.1s Multiple Spanning Tree Protocol (MSTP)
 - Supports EtherWAN's Alpha-Ring topology for less than 15ms fault recovery time
- VLANs
 - Port-based VLANs
 - IEEE802.1Q Tag VLANs (128 groups, 4096 VID)
 - GVRP (GARP VLAN Registration Protocol)
 - GMRP (GARP Multicast Registration Protocol)
- Link Aggregation
 - Static Trunk (2 groups, support MAC base)
 - IEEE802.3ad Link Aggregation Control Protocol
- IGMP Snooping
 - IGMP snooping v1/v2/v3

Performance

- Switching Capability: 7.2Gbps
- Packet Buffer Size: 2M bits
- MAC Address Table: 8192

Hardware Specifications

Technology

Standards

- IEEE802.3 10BASE-T
- IEEE802.3u 100BASE-TX/100BASE-FX
- IEEE802.3ab 1000BASE-T
- IEEE802.3z 1000BASE-SX/1000BASE-LX
- IEEE802.3x Full duplex and flow control
- IEEE802.1p QoS
- IEEE802.1Q Tag VLANs
- IEEE802.1w RSTP
- IEEE802.1x Port-based Network Access Control
- IEEE802.3af/at Power over Ethernet (PoE)

Forward and Filtering Rate

- 14,880pps for 10Mbps
- 148,810pps for 100Mbps
- 1,488,100pps for 1000Mbps

Packet Buffer Memory

- 2M bits

Processing Type

- Store-and-Forward
- Auto Negotiation
- Half-duplex back-pressure and IEEE802.3x full-duplex flow control
- Auto MDI/MDIX

Address Table Size

- 8192 MAC addresses

Power

Input

- Redundant power inputs:
Terminal Block: 47 - 55VDC (IEEE802.3af version)
Terminal Block: 52 - 57VDC (IEEE802.3at version)

Power Consumption

- Max. 12W (without PoE)
- PoE power budget (depends on power input):
246.4W (IEEE802.3af version)
480W Max. (IEEE802.3at version)

PoE Power Output

- IEEE802.3af: up to 15.4W/port
- IEEE802.3at: up to 30W/port

Protection

- Overload current protection
- Reverse polarity protection

Mechanical

Casing

- Metal Case
- IP30

Dimensions

- 442mm (W) x 205mm (D) x 44mm (H)
17.40" (W) x 8.07" (D) x 1.73" (H)

Weight

- 3.5Kg (7.7lbs.)

Installation

- Rack mounting

Interface

Ethernet Port

- 10/100BASE-TX: 16, 12 or 8 ports
- 100BASE-FX: 0, 2 or 4 ports
- Gigabit: 0, 1 or 2 ports

Console Port

- Port: One DB9 RS-232 port

LED Indicators

- Per Unit: Power 1, Power 2
- Per PoE Port: PoE (Amber)
- Per Port: Link/Activity (Green), Speed (Green)

Environment

Operating Temperature

- -40°C to 75°C (-40°F to 167°F)
Tested @ -40°C to 85°C (-40°F to 185°F)

Storage Temperature

- -45°C to 85°C (-49°F to 185°F)

Ambient Relative Humidity

- 5% to 95% (non-condensing)

Regulatory Approvals

ISO

- Manufactured in an ISO9001 facility

Safety

UL508

EMI

FCC Part 15B, Class A

EN61000-6-4

EN55022

EN61000-3-2

EN61000-3-3

EMS

EN61000-6-2

- EN61000-4-2 (ESD Standards)
- EN61000-4-3 (Radiated RFI Standards)
- EN61000-4-4 (Burst Standards)
- EN61000-4-5 (Surge Standards)
- EN61000-4-6 (Induced RFI Standards)
- EN61000-4-8 (Magnetic Field Standards)

Environmental Test Compliance

IEC60068-2-6 Fc (Vibration Resistance)

IEC60068-2-27 Ea (Shock)

FED STD 101C Method 5007.1 (Free fall w/package)

Application Diagram

The EX76000 Series can be installed in an indoor/outdoor rack to connect with IEEE802.3af/at compliant PoE Powered Devices in mission-critical environments.

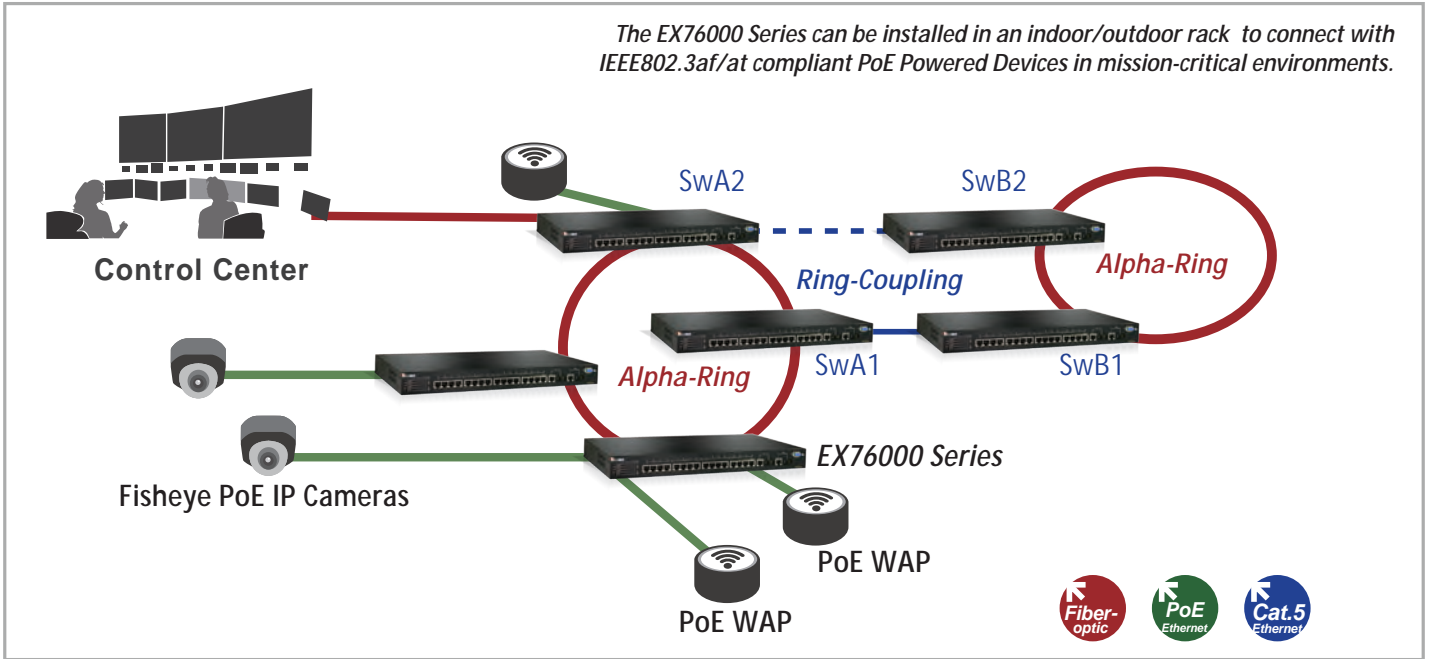

Dimensions

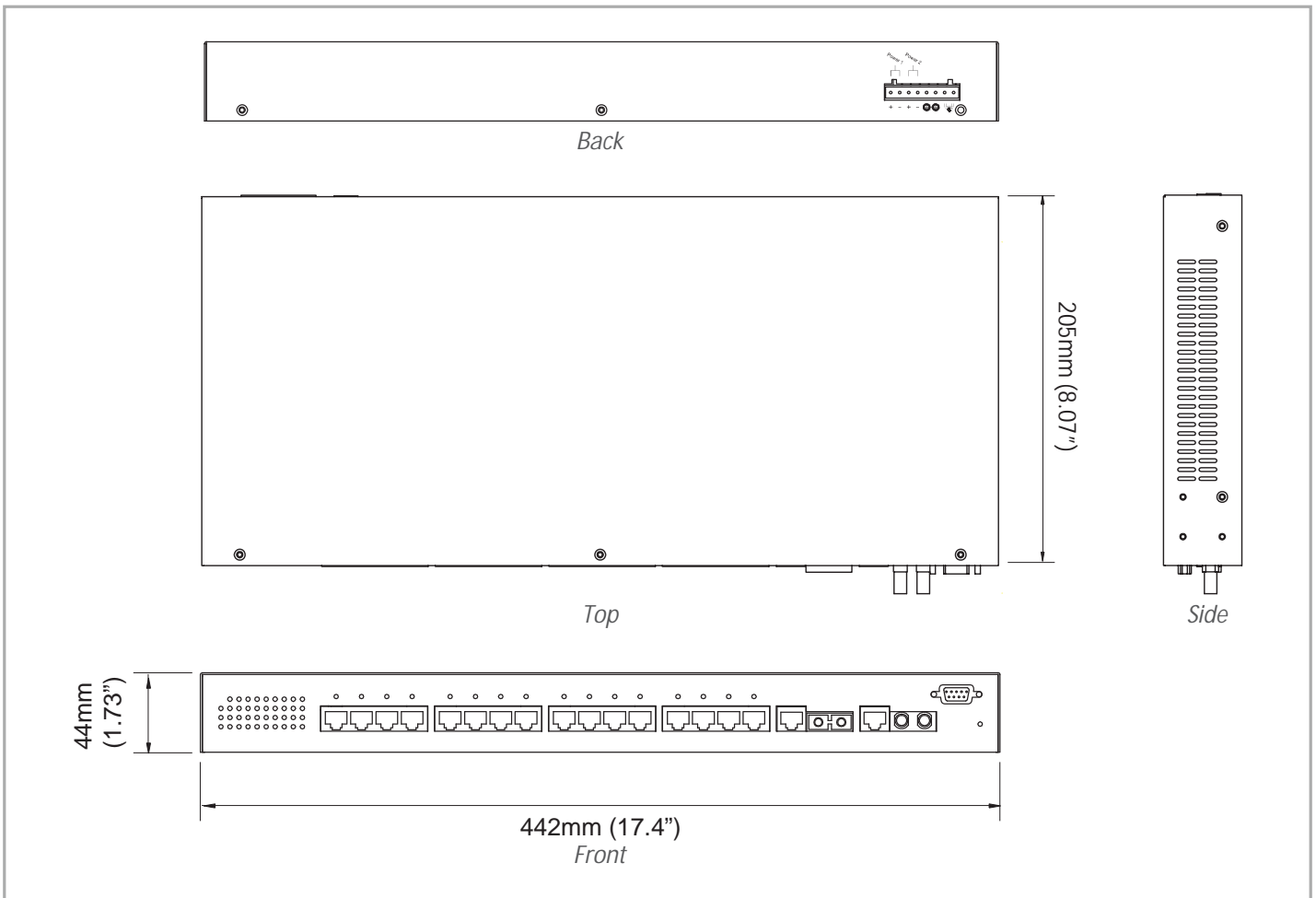

Ordering Information

Model

EX76400-00TP	16-port 10/100BASE-TX PoE Hardened Managed Ethernet Switch
EX76401-0YTP	16-port 10/100BASE-TX PoE + 1-port combo Gigabit Hardened Managed Ethernet Switch
EX76402-0YTP	16-port 10/100BASE-TX PoE + 2-port combo Gigabit Hardened Managed Ethernet Switch
EX76300-00TP	12-port 10/100BASE-TX PoE Hardened Managed Ethernet Switch
EX76301-0YTP	12-port 10/100BASE-TX PoE + 1-port combo Gigabit Hardened Managed Ethernet Switch
EX76302-0YTP	12-port 10/100BASE-TX PoE + 2-port combo Gigabit Hardened Managed Ethernet Switch
EX76320-X0TP	12-port 10/100BASE-TX PoE + 2-port 100BASE-FX Hardened Managed Ethernet Switch
EX76321-XYTP	12-port 10/100BASE-TX PoE + 2-port 100BASE-FX + 1-port combo Gigabit Hardened Managed Ethernet Switch
EX76322-XYTP	12-port 10/100BASE-TX PoE + 2-port 100BASE-FX + 2-port combo Gigabit Hardened Managed Ethernet Switch
EX76200-00TP	8-port 10/100BASE-TX PoE Hardened Managed Ethernet Switch
EX76201-0YTP	8-port 10/100BASE-TX PoE + 1-port combo Gigabit Hardened Managed Ethernet Switch
EX76202-0YTP	8-port 10/100BASE-TX PoE + 2-port combo Gigabit Hardened Managed Ethernet Switch
EX76220-X0TP	8-port 10/100BASE-TX PoE + 2-port 100BASE-FX Hardened Managed Ethernet Switch
EX76221-XYTP	8-port 10/100BASE-TX PoE + 2-port 100BASE-FX + 1-port combo Gigabit Hardened Managed Ethernet Switch
EX76222-XYTP	8-port 10/100BASE-TX PoE + 2-port 100BASE-FX + 2-port combo Gigabit Hardened Managed Ethernet Switch
EX76240-X0TP	8-port 10/100BASE-TX PoE + 4-port 100BASE-FX Hardened Managed Ethernet Switch
EX76241-XYTP	8-port 10/100BASE-TX PoE + 4-port 100BASE-FX + 1-port combo Gigabit Hardened Managed Ethernet Switch
EX76242-XYTP	8-port 10/100BASE-TX PoE + 4-port 100BASE-FX + 2-port combo Gigabit Hardened Managed Ethernet Switch

* Rack mounting kit included

100FX Fiber Options (X)

1	Multi Mode (SC) - 2Km
2	Multi Mode (ST) - 2Km
6	Multi Mode (SC) WDM-TX:1310nm/RX:1550nm - 2Km
7	Multi Mode (SC) WDM-TX:1550nm/RX:1310nm - 2Km
8	Multi Mode (SC) WDM-TX:1310nm/RX:1550nm - 5Km
9	Multi Mode (SC) WDM-TX:1550nm/RX:1310nm - 5Km
A	Single Mode (SC) - 20Km
B	Single Mode (SC) - 40Km
H	Single Mode (ST) - 20Km
P	Single Mode (SC) WDM-TX:1310nm/RX:1550nm - 20Km
Q	Single Mode (SC) WDM-TX:1550nm/RX:1310nm - 20Km
R	Single Mode (SC) WDM-TX:1310nm/RX:1550nm - 40Km
S	Single Mode (SC) WDM-TX:1550nm/RX:1310nm - 40Km

*More 100FX Fiber options also available upon request.

Ordering Information - continued

Gigabit Port Options (Y)

1	10/100/1000BASE-TX (No Gigabit Fiber port supported)
3	Combo port: 10/100/1000BASE-TX with 1000BASE-SX(SC) - 550m
4	Combo port: 10/100/1000BASE-TX with 1000BASE-SX (SC) - 2Km
5	Combo port: 10/100/1000BASE-TX with 1000BASE-SX (ST) - 550m
A	Combo port: 10/100/1000BASE-TX with 1000BASE-LX (SC) - 10Km
B	Combo port: 10/100/1000BASE-TX with 1000BASE-LX (SC) - 20Km
R	Combo port: 10/100/1000BASE-TX with 1000BASE-BX (SC) WDM-TX:1310nm/RX:1550nm - 20Km
S	Combo port: 10/100/1000BASE-TX with 1000BASE-BX (SC) WDM-TX:1550nm/RX:1310nm - 20Km

* More Gigabit options also available upon request.

PoE Type (P)

T	16 ports of IEEE802.3at
---	-------------------------

* If no alphabet specified, the model has 16 ports of IEEE802.3af

Optional Accessories

DR-120-48	120W/2.5A DIN-Rail 48VDC industrial power supply
SDR-240-48	240W/5A DIN-rail 48VDC industrial power supply
SDR-480-48	480W/10A DIN-Rail 48VDC industrial power supply

EX83000 Series

IEC61850/IEEE1613 Managed Hardened 16-port 10/100BASE with 2-port Gigabit combo Ethernet Switch



Overview

EtherWAN's EX83000 Series provides a Hardened Fully Managed 18-port switching platform combining high performance switching backbone with robust and secure management features required for mission critical and harsh environments where sustained connectivity is crucial.

The EX83000 Series is equipped with Sixteen 10/100BASE Fast Ethernet ports, in combination with up to Two Gigabit, Fixed Fiber, or SFP Combo port options. Mountable on a DIN-rail. The EX83000 Series is equipped with EtherWAN's Alpha-Ring self-healing technology, providing less than 15ms fault recovery time making it ideal for applications intolerant to interruption.

Users are able to access management features such as port security, IGMP snooping, VLANs, GARP protocols, LACP, and GOOSE messaging to name a few, via web browser, Telnet, SNMP, RMON, TFTP, and RS-232 console interfaces. With its hardened-grade specifications and IEC61850 & IEEE1613 certifications, the EX83000 Series is capable of operating under high EMI environments at the temperatures ranging from -40°C to 75°C , making it an ideal choice for harsh applications.

EtherWAN — "When Connectivity is Crucial."

Spotlight

• Hardened Grade

- Wide operating temperature range from -40°C to 75°C (-40°F to 167°F) for extreme environments
- Fanless and ruggedized housing
- High shock and electric noise immunity
- IEC61850/IEEE1613 compliant for applications in power substation zones

• Versatile Connectivity

- Provides 16-port 10/100BASE-TX/FX/BX/SFP plus 2-port Gigabit-SX/LX/BX/SFP combo

Software Features

Management

- Interface
 - CLI, Telnet and Web Browser
 - SNMP v1/v2c/v3
- Firmware and configuration upgrade and backup via TFTP
- Supports DHCP Server/Client
- RMON (Remote monitoring): group 1, 2, 3, 9
- Port mirroring: TX/RX and both
- NTP (Network Time Protocol) time synchronization
- IEEE802.1ab LLDP (Link Layer Discovery Protocol)

Security

- MAC address filtering
- Enable/disable port
- Storm control (broadcast and multicast types)
- IEEE802.1x LAN access control
- Remote authentication through RADIUS
- SSH for CLI and Telnet security
- SSL for web security
- Multi-level user account/password against unauthorized configuration
- System log (remote/local)

Quality of Service (QoS)

- Priority Queues: 4 queues per port
- Traffic classification based on IEEE802.1p CoS, DSCP, WRR (Weighted round robin) and strict mode
- Rate Limiting (Ingress/Egress)

Layer 2 Features

- Auto-negotiation for port speed and duplex mode
- Flow Control
 - IEEE802.3x full duplex mode
 - Back-Pressure half duplex mode
- Redundant Protocol
 - IEEE802.1D Spanning Tree Protocol (STP)
 - IEEE802.1w Rapid Spanning Tree Protocol (RSTP)
 - IEEE802.1s Multiple Spanning Tree Protocol (MSTP)
 - EtherWAN's Alpha-Ring network fault recovery (<15ms)
- VLANs
 - Port-based VLANs
 - IEEE802.1Q Tag VLANs (128 groups, 4096 VID)
 - GVRP (GARP VLAN Registration Protocol)
 - GMRP (GARP Multicast Registration Protocol)
- Link Aggregation
 - Static Trunk (2 groups, support MAC base)
 - IEEE802.3ad Link Aggregation Control Protocol
- IGMP Snooping
 - IGMP snooping v1/v2/v3

Performance

- Switching Capability: 7.2Gbps
- Packet Buffer Size: 2M bits
- MAC Address Table: 8192

Hardware Specifications

Technology

Standards

- IEEE802.3, 10BASE-T
- IEEE802.3u 100BASE-TX/100BASE-FX
- IEEE802.3ab 1000BASE-T
- IEEE802.3z 1000BASE-SX/1000BASE-LX
- IEEE802.3x Full duplex and flow control
- IEEE802.1p QoS
- IEEE802.1Q Tag VLANs
- IEEE802.1w RSTP
- IEEE802.1x Port-based Network Access Control

Forward and Filtering Rate

- 14,880pps for 10Mbps
- 148,810pps for 100Mbps
- 1,488,100pps for 1000Mbps

Packet Buffer Memory

- 2M bits

Processing Type

- Store-and-Forward
- Auto Negotiation
- Half-duplex back-pressure and IEEE802.3x full-duplex flow control
- Auto MDI/MDIX

Address Table Size

- 8192 MAC addresses

Power

Input Voltage

- 12 - 48VDC (Terminal Block)
- 12VDC (DC Jack)

Power Consumption

- 15W Max. 1.25A @ 12VDC, 0.625A @ 24VDC

Protection

- Overload current protection
- Reverse polarity protection

Mechanical

Casing

- Aluminum Case
- IP30

Dimensions

- 84mm (W) x 125mm (D) x 145mm (H)
3.3" (W) x 4.92" (D) x 5.71" (H)

Weight

- 1.4Kg (3.08lbs.)

Installation

- DIN-Rail (Top hat type 35mm) or Wall mounting

Interface

Ethernet Port

- 10/100BASE-TX: 16, 12 or 8 ports
- 100BASE-FX: 0, 1, 2 or 4 ports
- Gigabit: 0, 1 or 2 ports

Console Port

- Port: One DB9 RS-232 port

LED Indicators

- Per Unit: Power 1, Power 2, Power 3
- Per Port: Link/Activity
(Green: Copper, Orange: Fiber)

Alarm Contact

- One relay output with current 1A @ 24VDC

Environment

Operating Temperature

- -40°C to 75°C (-40°F to 167°F)
Tested @ -40°C to 80°C (-40°F to 176°F)

Storage Temperature

- -45°C to 85°C (-49°F to 185°F)

Ambient Relative Humidity

- 5% to 95% (non-condensing)

Regulatory Approvals

ISO

- Manufactured in an ISO9001 facility

EMI

FCC Part 15B, Class A

EN61000-6-4

EN61000-3-2

EN61000-3-3

EN55022

EMS

EEN61000-6-2

- EN61000-4-2 (ESD Standards)
- EN61000-4-3 (Radiated RFI Standards)
- EN61000-4-4 (Burst Standards)
- EN61000-4-5 (Surge Standards)
- EN61000-4-6 (Induced RFI Standards)
- EN61000-4-8 (Magnetic Field Standards)
- IEC61000-4-10 (Oscillatory wave magnetic field test)
- IEC61000-4-16 (Power frequency immunity test)
- IEC61000-4-18 (Oscillatory wave immunity test)

Environmental Test Compliance

IEC60068-2-6 Fc (Vibration Resistance)

IEC60068-2-27 Ea (Shock)

FED STD 101C Method 5007.1 (Free fall w/ package)

Industrial Compliance

IEEE61850-3 / IEEE1613

EN50121-4

NEMA TS2

Application Diagram

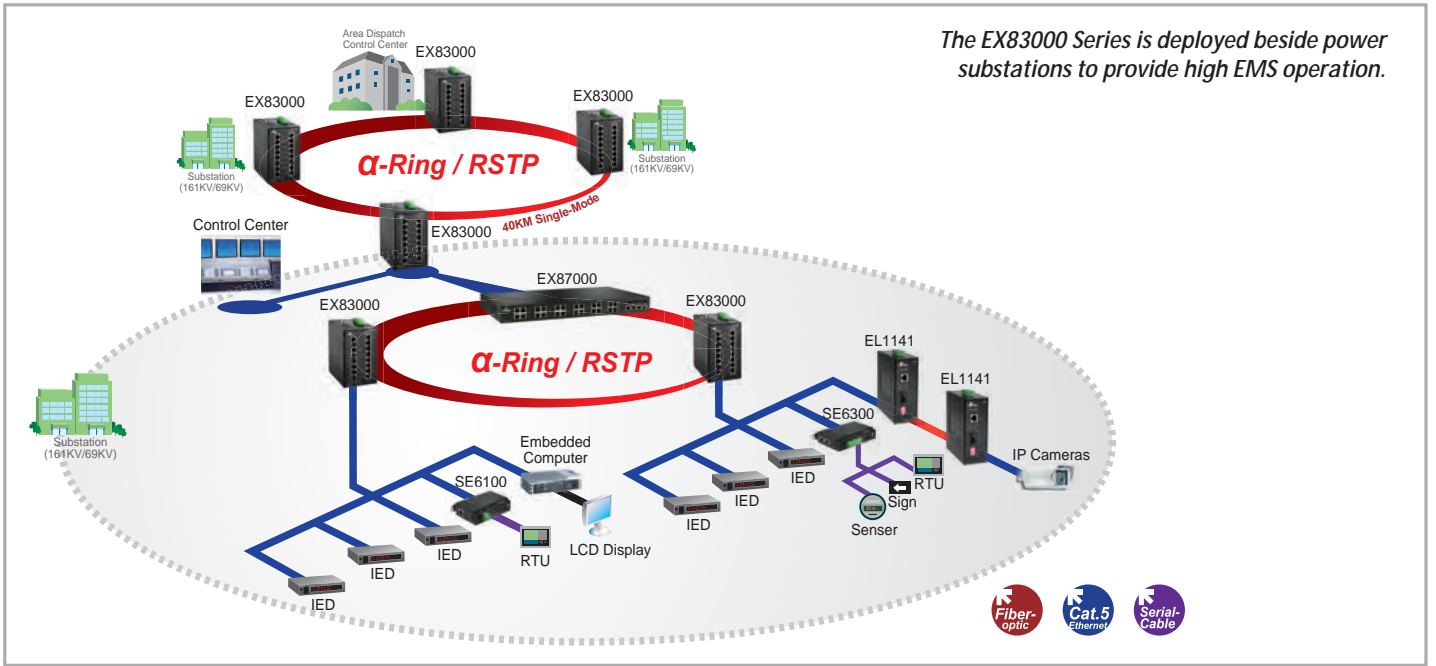

Dimensions

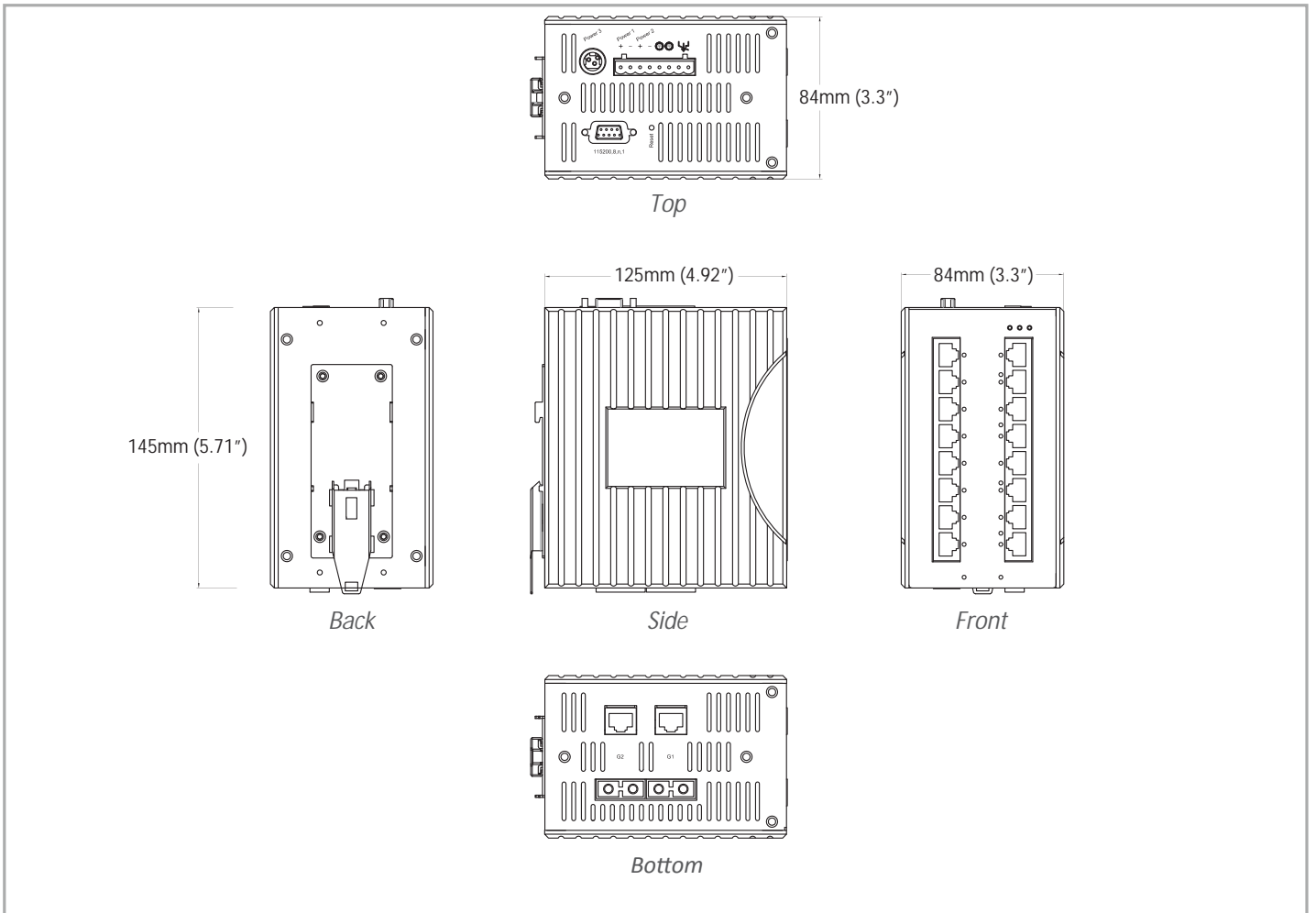

Ordering Information

Model

EX83400-00B	16-port 10/100BASE-TX Hardened Managed Ethernet Switch
EX83401-0YB	16-port 10/100BASE-TX + 1-port Gigabit Hardened Managed Ethernet Switch
EX83402-0YB	16-port 10/100BASE-TX + 2-port Gigabit Hardened Managed Ethernet Switch
EX83310-X0B	12-port 10/100BASE-TX + 1-port 100BASE-FX Hardened Managed Ethernet Switch
EX83311-XYB	12-port 10/100BASE-TX + 1-port 100BASE-FX + 1-port Gigabit Hardened Managed Ethernet Switch
EX83312-XYB	12-port 10/100BASE-TX + 1-port 100BASE-FX + 2-port Gigabit Hardened Managed Ethernet Switch
EX83320-X0B	12-port 10/100BASE-TX + 2-port 100BASE-FX Hardened Managed Ethernet Switch
EX83321-XYB	12-port 10/100BASE-TX + 2-port 100BASE-FX + 1-port Gigabit Hardened Managed Ethernet Switch
EX83322-XYB	12-port 10/100BASE-TX + 2-port 100BASE-FX + 2-port Gigabit Hardened Managed Ethernet Switch
EX83200-00B	8-port 10/100BASE-TX Hardened Managed Ethernet Switch
EX83201-0YB	8-port 10/100BASE-TX + 1-port Gigabit Hardened Managed Ethernet Switch
EX83202-0YB	8-port 10/100BASE-TX + 2-port Gigabit Hardened Managed Ethernet Switch
EX83210-X0B	8-port 10/100BASE-TX + 1-port 100BASE-FX Hardened Managed Ethernet Switch
EX83211-XYB	8-port 10/100BASE-TX + 1-port 100BASE-FX + 1-port Gigabit Hardened Managed Ethernet Switch
EX83212-XYB	8-port 10/100BASE-TX + 1-port 100BASE-FX + 2-port Gigabit Hardened Managed Ethernet Switch
EX83220-X0B	8-port 10/100BASE-TX + 2-port 100BASE-FX Hardened Managed Ethernet Switch
EX83221-XYB	8-port 10/100BASE-TX + 2-port 100BASE-FX + 1-port Gigabit Hardened Managed Ethernet Switch
EX83222-XYB	8-port 10/100BASE-TX + 2-port 100BASE-FX + 2-port Gigabit Hardened Managed Ethernet Switch
EX83240-X0B	8-port 10/100BASE-TX + 4-port 100BASE-FX Hardened Managed Ethernet Switch
EX83241-XYB	8-port 10/100BASE-TX + 4-port 100BASE-FX + 1-port Gigabit Hardened Managed Ethernet Switch
EX83242-XYB	8-port 10/100BASE-TX + 4-port 100BASE-FX + 2-port Gigabit Hardened Managed Ethernet Switch

* DIN-Rail mounting kit included

100FX Fiber Options (X)

1	Multi Mode (SC) - 2Km
2	Multi Mode (ST) - 2Km
6	Multi Mode (SC) WDM-TX:1310nm/RX:1550nm - 2Km
7	Multi Mode (SC) WDM-TX:1550nm/RX:1310nm - 2Km
8	Multi Mode (SC) WDM-TX:1310nm/RX:1550nm - 5Km
9	Multi Mode (SC) WDM-TX:1550nm/RX:1310nm - 5Km
A	Single Mode (SC) - 20Km
B	Single Mode (SC) - 40Km
H	Single Mode (ST) - 20Km
P	Single Mode (SC) WDM-TX:1310nm/RX:1550nm - 20Km
Q	Single Mode (SC) WDM-TX:1550nm/RX:1310nm - 20Km
R	Single Mode (SC) WDM-TX:1310nm/RX:1550nm - 40Km
S	Single Mode (SC) WDM-TX:1550nm/RX:1310nm - 40Km
V	100BASE SFP

Ordering Information - continued

Gigabit Port Options (Y)

1	10/100/1000BASE-TX (No Gigabit Fiber port supported)
3	Combo port: 10/100/1000BASE-TX with 1000BASE-SX(SC) - 550m
4	Combo port: 10/100/1000BASE-TX with 1000BASE-SX (SC) - 2Km
5	Combo port: 10/100/1000BASE-TX with 1000BASE-SX (ST) - 550m
A	Combo port: 10/100/1000BASE-TX with 1000BASE-LX (SC) - 10Km
B	Combo port: 10/100/1000BASE-TX with 1000BASE-LX (SC) - 20Km
R	Combo port: 10/100/1000BASE-TX with 1000BASE-BX (SC) WDM-TX:1310nm/RX:1550nm - 20Km
S	Combo port: 10/100/1000BASE-TX with 1000BASE-BX (SC) WDM-TX:1550nm/RX:1310nm - 20Km
V	Combo port: 1000BASE-SFP with 10/100/1000BASE-TX

Optional Accessories

KP-AA96-480	Panel mounting Kits
DR-30-24	30W/1.5A DIN-Rail 24VDC Industrial Power Supply (for Terminal Block)
DR-60--24	60W/2.5A DIN-Rail 24VDC Industrial Power Supply (for Terminal Block)
DR-120-24	120W/5A DIN-Rail 24VDC Industrial Power Supply (for Terminal Block)
41-136046-X	36W/3A 12VDC hardened power adapter with open wire in aluminum housing (for Terminal Block) (X)= 1: US, 2: EU, 3: UK, 4: AU, 5: JP, 6: SA
41-136044-X	36W/3A 12VDC hardened power adapter with latched DC Jack in aluminum housing (for DC Jack) (X)= 1: US, 2: EU, 3: UK, 4: AU, 5: JP, 6: SA

EX73000 Series

Hardened Managed 16-port 10/100BASE with 2-port Gigabit combo Ethernet Switch



Overview

EtherWAN's EX73000 Series provides a Hardened Fully Managed 18-port switching platform combining high performance switching backbone with robust and secure management features required for mission critical and harsh environments where sustained connectivity is crucial.

The EX73000 Series is equipped with sixteen 10/100BASE Fast Ethernet ports, in combination with up to two Gigabit combo ports with fixed Fiber options. Mountable on a DIN-rail, the EX73000 Series is equipped with EtherWAN's Alpha-Ring self-healing technology, providing less than 15ms fault recovery time making it ideal for applications intolerant to interruption.

Users are able to access management features such as port security, IGMP snooping, VLANs, GARP protocols, LACP to name a few, and via web browser, Telnet, SNMP, RMON, TFTP, and RS-232 console interfaces.

EtherWAN — "When Connectivity is Crucial."

Spotlight

• Versatile Connectivity

- Provides 16-port 10/100BASE-TX/FX/BX/SFP plus 2-port Gigabit-SX/LX/BX/SFP combo

• Hardened Grade

- Wide operating temperature range from -40°C to 75°C (-40°F to 167°F) for extreme environments
- Fanless and ruggedized housing

• Secure Remote Access

- IEEE802.1x, and RADIUS support

• ISA12.12.01 Certification

- Highly qualified for explosive environmental applications and certified by UL with ISA12.12.01 Class I, Division 2 classified for use in hazardous locations

Software Features

Management

- Interface
 - CLI, Telnet and Web Browser
 - SNMP v1/v2c/v3
- Firmware and configuration upgrade and backup via TFTP
- Supports DHCP Server/Client
- RMON (Remote monitoring): group 1, 2, 3, 9
- Port mirroring: TX/RX and both
- NTP (Network Time Protocol) time synchronization
- IEEE802.1ab LLDP (Link Layer Discovery Protocol)

Security

- MAC address filtering
- Enable/disable port
- Storm control (broadcast and multicast types)
- IEEE802.1x LAN access control
- Remote authentication through RADIUS
- SSH for CLI and Telnet security
- SSL for web security
- Multi-level user account/password against unauthorized configuration
- System log (remote/local)

Quality of Service (QoS)

- Priority Queues: 4 queues per port
- Traffic classification based on IEEE802.1p CoS, DSCP, WRR (Weighted round robin) and strict mode
- Rate Limiting (Ingress/Egress)

Layer 2 Features

- Auto-negotiation for port speed and duplex mode
- Flow Control
 - IEEE802.3x full duplex mode
 - Back-Pressure half duplex mode
- Redundant Protocol
 - IEEE802.1D Spanning Tree Protocol (STP)
 - IEEE802.1w Rapid Spanning Tree Protocol (RSTP)
 - IEEE802.1s Multiple Spanning Tree Protocol (MSTP)
 - EtherWAN's α -Ring network fault recovery (<15ms)
- VLANs
 - Port-based VLANs
 - IEEE802.1Q Tag VLANs (128 groups, 4096 VID)
 - GVRP (GARP VLAN Registration Protocol)
 - GMRP (GARP Multicast Registration Protocol)
- Link Aggregation
 - Static Trunk (2 groups, support MAC base)
 - IEEE802.3ad Link Aggregation Control Protocol
- IGMP Snooping
 - IGMP snooping v1/v2/v3

Performance

- Switching Capability: 7.2Gbps
- Packet Buffer Size: 2M bits
- MAC Address Table: 8192

Hardware Specifications

Technology

Standards

- IEEE802.3 10BASE-T
- IEEE802.3u 100BASE-TX/100BASE-FX
- IEEE802.3ab 1000BASE-T
- IEEE802.3z 1000BASE-SX/1000BASE-LX
- IEEE802.3x Full duplex and flow control
- IEEE802.1p Quality of Service (QoS)
- IEEE802.1Q Tag VLANs
- IEEE802.1w RSTP
- IEEE802.1x Port-based Network Access Control

Forward and Filtering Rate

- 14,880pps for 10Mbps
- 148,810pps for 100Mbps
- 1,488,100pps for 1000Mbps

Packet Buffer Memory

- 2M bits

Processing Type

- Store-and-Forward
- Auto Negotiation
- Half-duplex back-pressure and IEEE802.3x full-duplex flow control
- Auto MDI/MDIX

Address Table Size

- 8192 MAC addresses

Power

Input

- Redundant power inputs:
 - 12 - 48VDC (Terminal Block),
 - 12VDC (DC Jack)

Power Consumption

- 15W Max. 1.25A @ 12VDC, 0.625A @ 24VDC

Protection

- Overload current protection
- Reverse polarity protection

Mechanical

Casing

- Aluminum Case
- IP30

Dimensions

- 65mm (W) x 125mm (D) x 145mm (H)
(2.56" (W) x 4.92" (D) x 5.71" (H))

Weight

- 1Kg (2.2lbs.)

Installation

- DIN-Rail (Top hat type 35mm) or Wall mounting

Interface

Ethernet Port

- 10/100BASE-TX: 16, 12 or 8 ports
- 100BASE-FX: 0, 1, 2 or 4 ports
- Gigabit: 0, 1 or 2 ports

Console Port

- Port: One DB9 RS-232 port

LED Indicators

- Per Unit: Power 1, Power 2, Power 3
- Per Port: Link/Activity
(Green: Copper, Orange: Fiber)

Alarm Contact

- One relay output with current 1A @ 24VDC

Environment

Operating Temperature

- -40°C to 75°C (-40°F to 167°F)
Tested @ -40°C to 85°C (-40°F to 185°F)

Storage Temperature

- -45°C to 85°C (-49°F to 185°F)

Ambient Relative Humidity

- 5% to 95% (non-condensing)

Regulatory Approvals

ISO

- Manufactured in an ISO9001 facility

Safety

UL508

ISA 12.12.01

EMI

FCC Part 15B, Class A

EN61000-6-4

EN55022

EN61000-3-2

EN61000-3-3

EMS

EN61000-6-2

- EN61000-4-2 (ESD Standards)
- EN61000-4-3 (Radiated RFI Standards)
- EN61000-4-4 (Burst Standards)
- EN61000-4-5 (Surge Standards)
- EN61000-4-6 (Induced RFI Standards)
- EN61000-4-8 (Magnetic Field Standards)

Environmental Test Compliances

IEC60068-2-6 Fc (Vibration Resistance)

IEC60068-2-27 Ea (Shock)

FED STD 101C Method 5007.1 (Free fall w/ package)

Industrial Compliance

NEMA TS2

Application Diagram

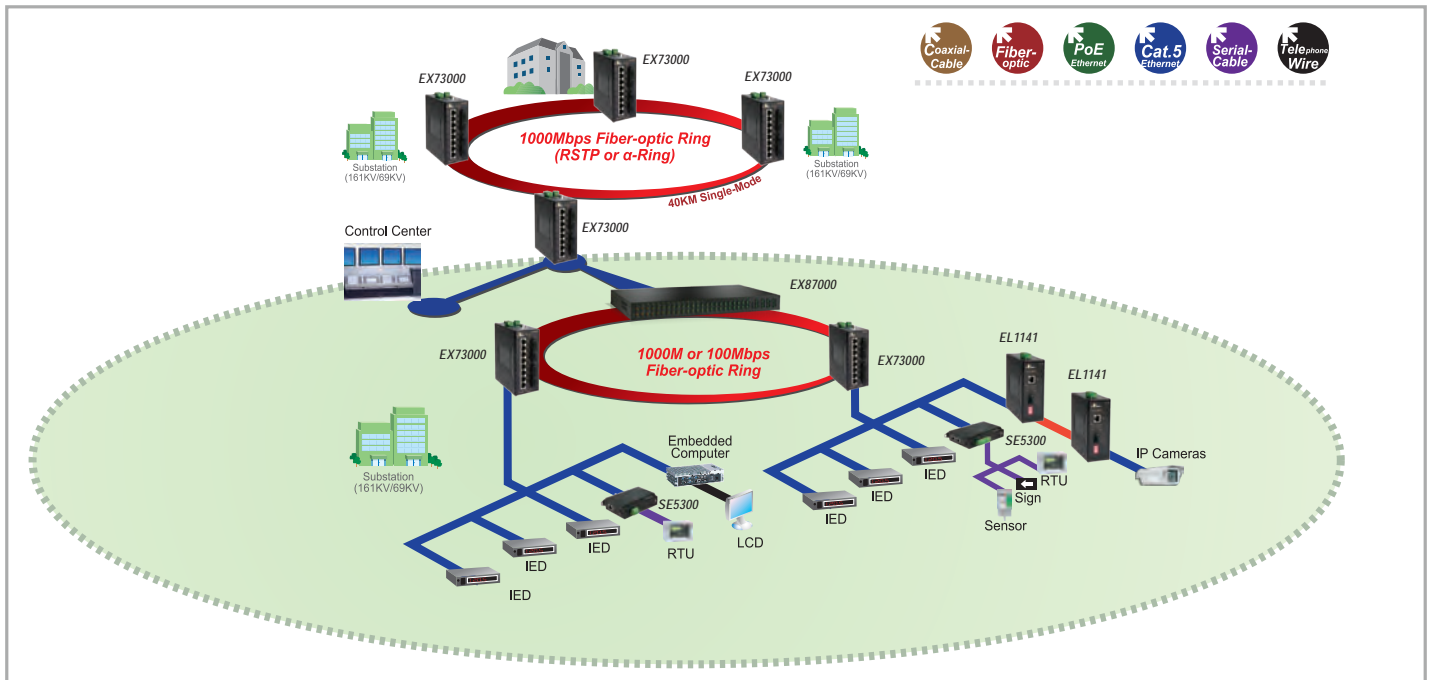

Dimensions

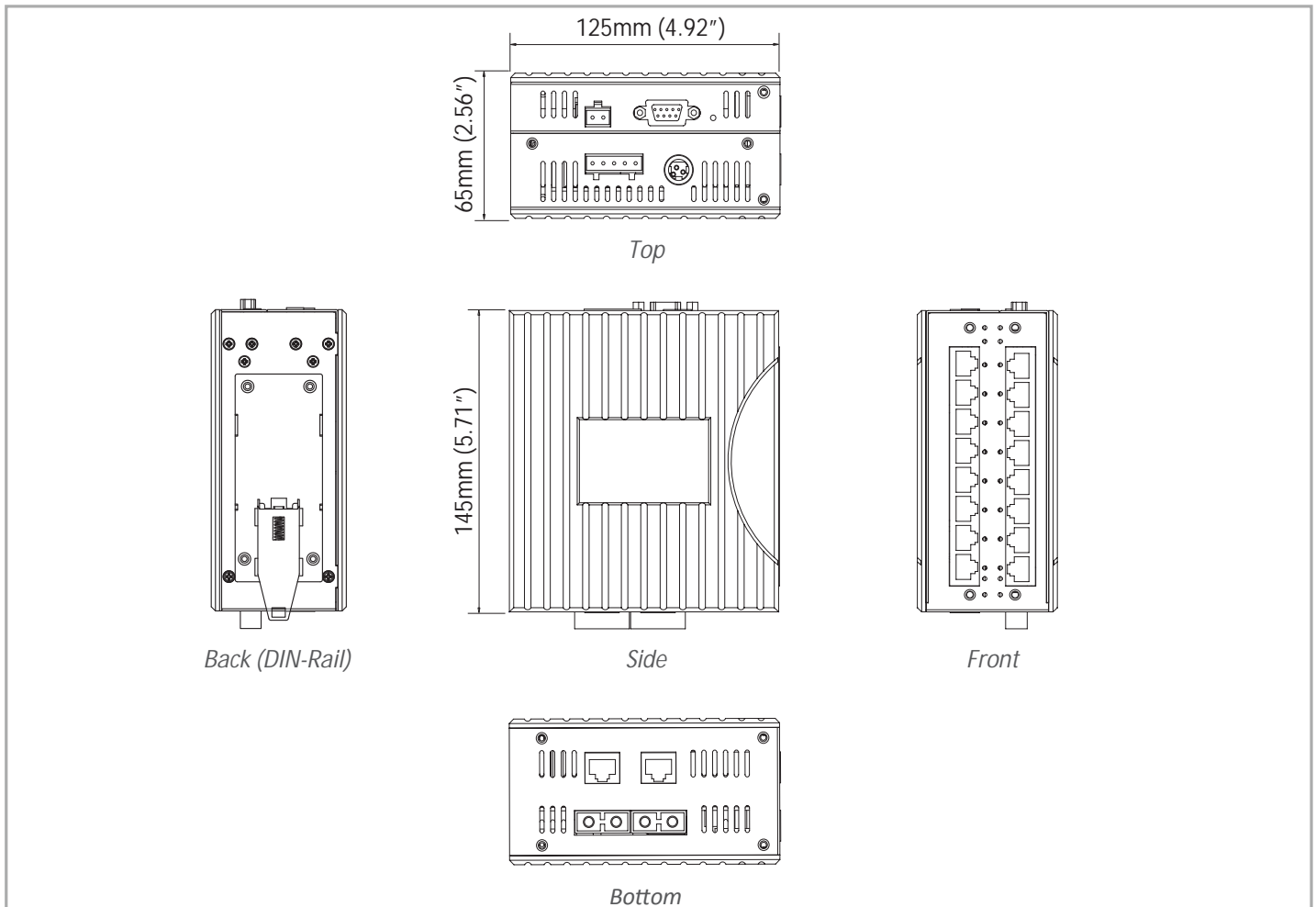

Ordering Information

Model

EX73400-00B	16-port 10/100BASE-TX Hardened Managed Ethernet Switch
EX73401-0YB	16-port 10/100BASE-TX + 1-port Gigabit Hardened Managed Ethernet Switch
EX73402-0YB	16-port 10/100BASE-TX + 2-port Gigabit Hardened Managed Ethernet Switch
EX73302-0YB	12-port 10/100BASE-TX + 2-port Gigabit Hardened Managed Ethernet Switch
EX73310-X0B	12-port 10/100BASE-TX + 1-port 100BASE-FX Hardened Managed Ethernet Switch
EX73311-XYB	12-port 10/100BASE-TX + 1-port 100BASE-FX + 1-port Gigabit Hardened Managed Ethernet Switch
EX73312-XYB	12-port 10/100BASE-TX + 1-port 100BASE-FX + 2-port Gigabit Hardened Managed Ethernet Switch
EX73320-X0B	12-port 10/100BASE-TX + 2-port 100BASE-FX Hardened Managed Ethernet Switch
EX73321-XYB	12-port 10/100BASE-TX + 2-port 100BASE-FX + 1-port Gigabit Hardened Managed Ethernet Switch
EX73322-XYB	12-port 10/100BASE-TX + 2-port 100BASE-FX + 2-port Gigabit Hardened Managed Ethernet Switch
EX73200-00B	8-port 10/100BASE-TX Hardened Managed Ethernet Switch
EX73201-0YB	8-port 10/100BASE-TX + 1-port Gigabit Hardened Managed Ethernet Switch
EX73202-0YB	8-port 10/100BASE-TX + 2-port Gigabit Hardened Managed Ethernet Switch
EX73210-X0B	8-port 10/100BASE-TX + 1-port 100BASE-FX Hardened Managed Ethernet Switch
EX73211-XYB	8-port 10/100BASE-TX + 1-port 100BASE-FX + 1-port Gigabit Hardened Managed Ethernet Switch
EX73212-XYB	8-port 10/100BASE-TX + 1-port 100BASE-FX + 2-port Gigabit Hardened Managed Ethernet Switch
EX73220-X0B	8-port 10/100BASE-TX + 2-port 100BASE-FX Hardened Managed Ethernet Switch
EX73221-XYB	8-port 10/100BASE-TX + 2-port 100BASE-FX + 1-port Gigabit Hardened Managed Ethernet Switch
EX73222-XYB	8-port 10/100BASE-TX + 2-port 100BASE-FX + 2-port Gigabit Hardened Managed Ethernet Switch
EX73240-X0B	8-port 10/100BASE-TX + 4-port 100BASE-FX Hardened Managed Ethernet Switch
EX73241-XYB	8-port 10/100BASE-TX + 4-port 100BASE-FX + 1-port Gigabit Hardened Managed Ethernet Switch
EX73242-XYB	8-port 10/100BASE-TX + 4-port 100BASE-FX + 2-port Gigabit Hardened Managed Ethernet Switch

* DIN-Rail mounting kit included

100FX Fiber Options (X)

1	Multi Mode (SC) - 2Km
2	Multi Mode (ST) - 2Km
6	Multi Mode (SC) WDM-TX:1310nm/RX:1550nm - 2Km
7	Multi Mode (SC) WDM-TX:1550nm/RX:1310nm - 2Km
8	Multi Mode (SC) WDM-TX:1310nm/RX:1550nm - 5Km
9	Multi Mode (SC) WDM-TX:1550nm/RX:1310nm - 5Km
A	Single Mode (SC) - 20Km
B	Single Mode (SC) - 40Km
H	Single Mode (ST) - 20Km
P	Single Mode (SC) WDM-TX:1310nm/RX:1550nm - 20Km
Q	Single Mode (SC) WDM-TX:1550nm/RX:1310nm - 20Km
R	Single Mode (SC) WDM-TX:1310nm/RX:1550nm - 40Km
S	Single Mode (SC) WDM-TX:1550nm/RX:1310nm - 40Km

Gigabit Port Options (Y)

1	10/100/1000BASE-TX (No Gigabit Fiber port supported)
3	Combo port: 10/100/1000BASE-TX with 1000BASE-SX(SC) - 550m
4	Combo port: 10/100/1000BASE-TX with 1000BASE-SX (SC) - 2Km
5	Combo port: 10/100/1000BASE-TX with 1000BASE-SX (ST) - 550m
A	Combo port: 10/100/1000BASE-TX with 1000BASE-LX (SC) - 10Km
B	Combo port: 10/100/1000BASE-TX with 1000BASE-LX (SC) - 20Km
R	Combo port: 10/100/1000BASE-TX with 1000BASE-BX (SC) WDM-TX:1310nm/RX:1550nm - 20Km
S	Combo port : 10/100/1000BASE-TX with 1000BASE-LX (SC) WDM-TX:1550nm/RX: 1310nm - 20Km

Optional Accessories

KP-AA96-480	Panel mounting Kits
DR-30-24	30W/1.5A DIN-Rail 24VDC Industrial Power Supply (for Terminal Block)
DR-60--24	60W/2.5A DIN-Rail 24VDC Industrial Power Supply (for Terminal Block)
DR-120-24	120W/5A DIN-Rail 24VDC Industrial Power Supply (for Terminal Block)
41-136046-X	36W/3A 12VDC hardened power adapter with open wire in aluminum housing (for Terminal Block); (X) = 1: US, 2: EU, 3: UK, 4: AU, 5: JP, 6: SA
41-136044-X	36W/3A 12VDC hardened power adapter with latched DC Jack in aluminum housing; (for DC Jack) (X) = 1: US, 2: EU, 3: UK, 4: AU, 5: JP, 6: SA

EX72000 Series

Hardened Managed 8 to 14 ports 10/100BASE and 2-port Gigabit Ethernet Switch with SFP options



Overview

EtherWAN's EX72000 Series provides a Hardened Fully Managed 14-port switching platform combining high performance switching backbone with robust and secure management features required for mission critical and harsh environments where sustained connectivity is crucial.

The EX72000 Series is equipped with eight to fourteen 10/100BASE Fast Ethernet ports, or in combination with up to Two Gigabit, Fixed Fiber, or SFP Combo port options. Panel mountable, the EX72000 Series is equipped with EtherWAN's Alpha-Ring self-healing technology, providing less than 15ms fault recovery time making it ideal for applications intolerant to interruption.

Users are able to access management features such as; port security, IGMP snooping, VLANs, GARP protocols, LACP, via web browser, Telnet, SNMP, RMON, TFTP, and RS-232 console interfaces.

EtherWAN — "When Connectivity is Crucial."

Spotlight

• Versatile Connectivity

- Provides flexibility of 8-port to 14-port 10/100BASE-TX/FX/BX plus 2-port Gigabit-TX/SX/LX/BX/SFP combos

• Intelligent Data Management

- Optimize network performance with QoS, VLAN etc.

• Secure Remote Access

- IEEE802.1x and RADIUS support

Software Features

Management

- Interface
 - CLI, Telnet and web browser
 - SNMP v1/v2c/v3
- Firmware and configuration upgrade and backup via TFTP
- Supports DHCP Server/Client
- RMON (Remote monitoring): group 1, 2, 3, 9
- Port mirroring: TX/RX and both
- NTP (Network Time Protocol) time synchronization
- IEEE802.1ab LLDP (Link Layer Discovery Protocol)

Security

- MAC address filtering
- Enable/disable port
- Storm control (broadcast and multicast types)
- IEEE802.1x LAN access control
- Remote authentication through RADIUS
- SSH for CLI and Telnet security
- SSL for web security
- Multi-level user account/password against unauthorized configuration
- System log (remote/local)

Quality of Service (QoS)

- Priority Queues: 4 queues per port
- Traffic classification based on IEEE802.1p CoS, DSCP, WRR (Weighted round robin) and strict mode
- Rate Limiting (Ingress/Egress)

Layer 2 Features

- Auto-negotiation for port speed and duplex mode
- Flow Control
 - IEEE802.3x full duplex mode
 - Back-Pressure half duplex mode
- Redundant Protocol
 - IEEE802.1D Spanning Tree Protocol (STP)
 - IEEE802.1w Rapid Spanning Tree Protocol (RSTP)
 - IEEE802.1s Multiple Spanning Tree Protocol (MSTP)
 - EtherWAN's Alpha-Ring network fault recovery (<15ms)
- VLANs
 - Port-based VLANs
 - IEEE802.1Q Tag VLANs (128 groups, 4096 VID)
 - GVRP (GARP VLAN Registration Protocol)
 - GMRP (GARP Multicast Registration Protocol)
- Link Aggregation
 - Static Trunk (2 groups, support MAC base)
 - IEEE802.3ad Link Aggregation Control Protocol
- IGMP Snooping
 - IGMP snooping v1/v2/v3

Performance

- Switching Capability: 6.4Gbps
- Packet Buffer Size: 2M bits
- MAC Address Table: 8192

Hardware Specifications

Technology

Standards

- IEEE802.3 10BASE-T
- IEEE802.3u 100BASE-TX/100BASE-FX
- IEEE802.3ab 1000BASE-T
- IEEE802.3z 1000BASE-SX/1000BASE-LX
- IEEE802.3x Full duplex and flow control
- IEEE802.1p QoS
- IEEE802.1Q Tag VLANs
- IEEE802.1w RSTP
- IEEE802.1x Port-based Network Access Control

Forward and Filtering Rate

- 14,880pps for 10Mbps
- 148,810pps for 100Mbps
- 1,488,100pps for 1000Mbps

Packet Buffer Memory

- 2M bits

Processing Type

- Store-and-Forward
- Auto Negotiation
- Half-duplex back-pressure and IEEE802.3x full-duplex flow control
- Auto MDI/MDIX

Address Table Size

- 8192 MAC addresses

Power

Input

- Redundant power inputs:
 - 12 - 48VDC (Terminal Block);
 - 12VDC (DC Jack)

Power Consumption

- 15W Max. 1.25A @ 12VDC, 0.625A @ 24VDC

Protection

- Overload current protection
- Reverse polarity protection

Mechanical

Casing

- Aluminum Case
- IP30

Dimensions

- 235mm (W) x 125mm (D) x 50mm (H)
(9.25" (W) x 4.92" (D) x 1.97" (H))

Weight

- 1.5Kg (3.3lbs.)

Installation

- DIN-Rail (Top hat type 35mm), Panel, or Rack mounting

Interface

Ethernet Port

- 10/100BASE-TX: 14, 13, 12 or 8 port
- 100BASE-FX: 0, 1 or 2 ports
- Gigabit: 0, 1 or 2 ports

Console Port

- Port: One DB9 RS-232 port

LED Indicators

- Per Unit: Power 1 (Green)
Power 2 (Green)
Power 3 (Green)
- Per Port: Link/Activity (Green)
10/100M (Green)

Environment

Operating Temperature

- -40°C to 75°C (-40°F to 167°F)
Tested @ -40°C to 85°C (-40°F to 185°F)

Storage Temperature

- -40°C to 85°C (-40°F to 185°F)

Ambient Relative Humidity

- 5% to 95% (non-condensing)

Regulatory Approvals

ISO

- Manufactured in an ISO9001 facility

Safety

UL508

EMI

FCC Part 15B, Class A

EN61000-6-4

EN55022

EN61000-3-2

EN61000-3-3

EMS

EN61000-6-2

- EN61000-4-2 (ESD Standards)
- EN61000-4-3 (Radiated RFI Standards)
- EN61000-4-4 (Burst Standards)
- EN61000-4-5 (Surge Standards)
- EN61000-4-6 (Induced RFI Standards)
- EN61000-4-8 (Magnetic Field Standards)

Environmental Test Compliance

IEC60068-2-6 Fc (Vibration Resistance)

IEC60068-2-27 Ea (Shock)

FED STD 101C Method 5007.1 (Free fall w/ package)

Industrial Compliance

NEMA TS2

Application Diagram

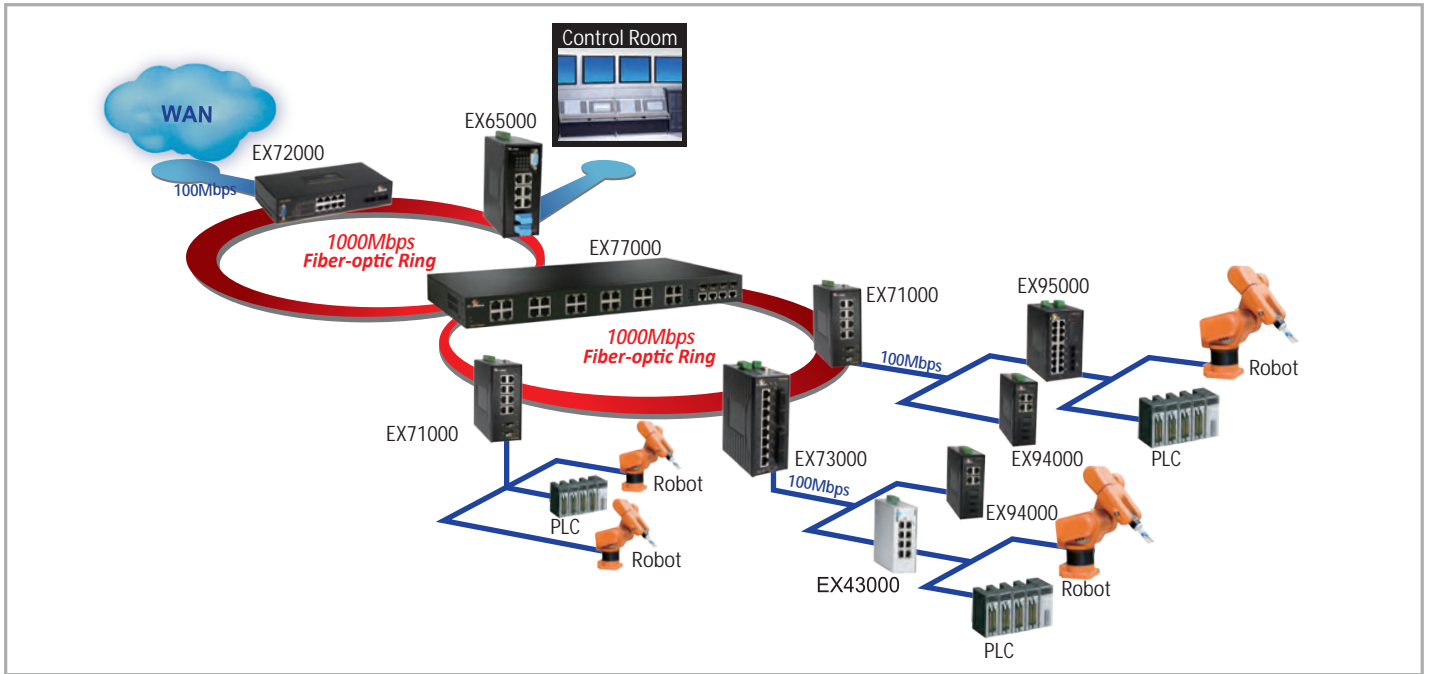

Dimensions

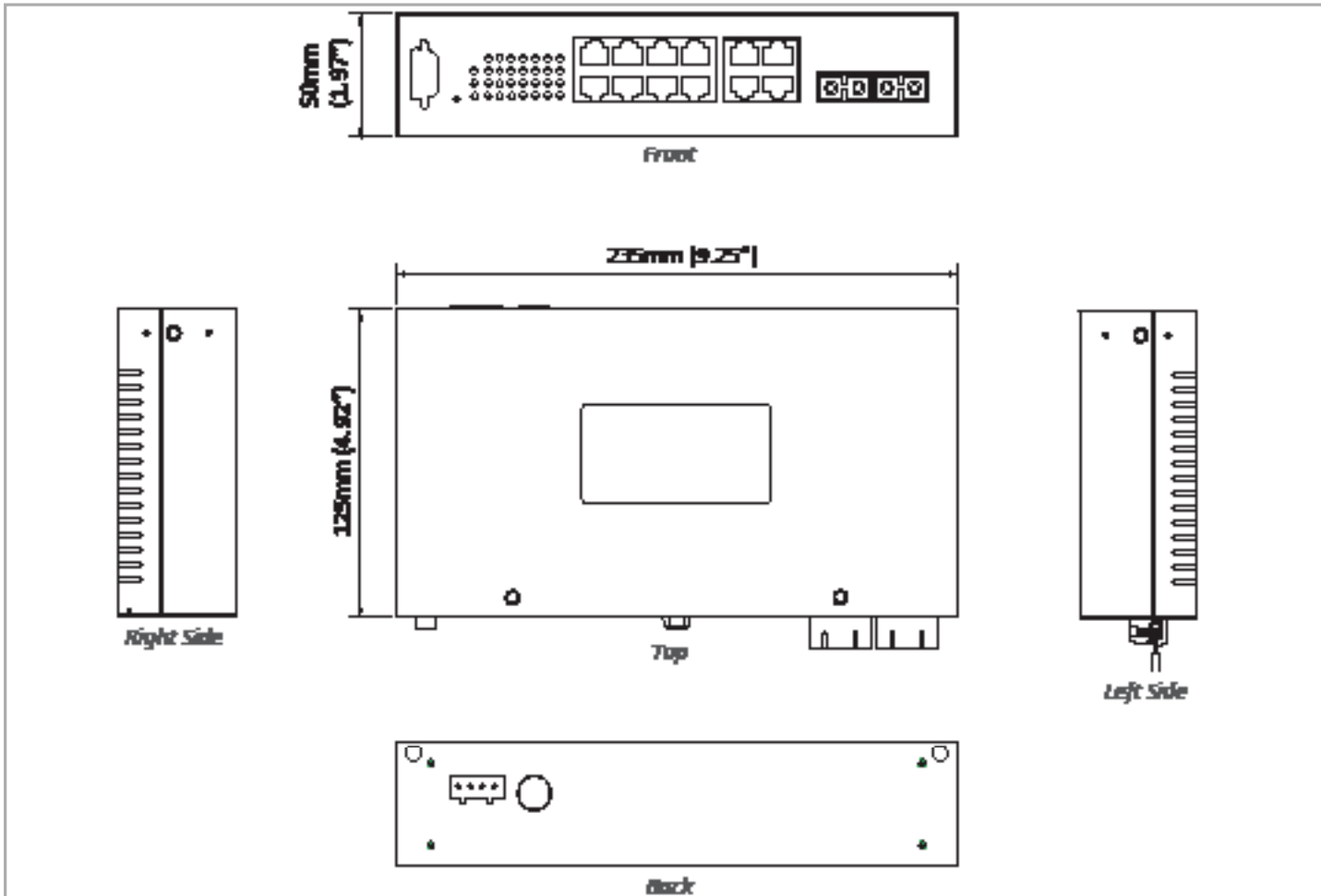

Ordering Information

Model

EX72140-00B	14-port 10/100BASE-TX Hardened Managed Ethernet Switch
EX72141-X0B	13-port 10/100BASE-TX + 1-port 100BASE-FX Hardened Managed Ethernet Switch
EX72142-X0B	12-port 10/100BASE-TX + 2-port 100BASE-FX Hardened Managed Ethernet Switch
EX72102-X0B	8-port 10/100BASE-TX + 2-port 100BASE-FX Hardened Managed Ethernet Switch
EX72128-0YB	12-port 10/100BASE-TX + 1-port Gigabit Hardened Managed Ethernet Switch
EX72129-0YB	12-port 10/100BASE-TX + 2-port Gigabit Hardened Managed Ethernet Switch
EX72088-0YB	8-port 10/100BASE-TX + 1-port Gigabit Hardened Managed Ethernet Switch
EX72089-0YB	8-port 10/100BASE-TX + 2-port Gigabit Hardened Managed Ethernet Switch

100FX Fiber Options (X)

1	Multi Mode (SC) - 2Km
2	Multi Mode (ST) - 2Km
6	Multi Mode (SC) WDM-TX:1310nm/RX:1550nm - 2Km
7	Multi Mode (SC) WDM-TX:1550nm/RX:1310nm - 2Km
8	Multi Mode (SC) WDM-TX:1310nm/RX:1550nm - 5Km
9	Multi Mode (SC) WDM-TX:1550nm/RX:1310nm - 5Km
A	Single Mode (SC) - 20Km
B	Single Mode (SC) - 40Km
H	Single Mode (ST) - 20Km
P	Single Mode (SC) WDM-TX:1310nm/RX:1550nm - 20Km
Q	Single Mode (SC) WDM-TX:1550nm/RX:1310nm - 20Km
R	Single Mode (SC) WDM-TX:1310nm/RX:1550nm - 40Km
S	Single Mode (SC) WDM-TX:1550nm/RX:1310nm - 40Km

Gigabit Port Options (Y)

1	10/100/1000BASE-TX
3	1000BASE-SX(SC) - 550m
4	1000BASE-SX (SC) - 2Km
5	1000BASE-SX (ST) - 550m
A	1000BASE-LX (SC) - 10Km
B	1000BASE-LX (SC) - 20Km
R	1000BASE-BX (SC) WDM-TX:1310nm/RX:1550nm - 20Km
S	1000BASE-BX (SC) WDM-TX: 1550nm/RX: 1310nm - 20Km
V	2-port 1000BASE SFP combo 10/100/1000BASE-TX

Optional Accessories

KD-AA96000	DIN-Rail mounting kit
KP-BK6212	Panel mounting kit
KR-BK72-400	Rack mounting kit
DR-30-24	30W/1.5A DIN-Rail 24VDC Industrial Power Supply (for Terminal Block)
DR-60--24	60W/2.5A DIN-Rail 24VDC Industrial Power Supply (for Terminal Block)
DR-75-24	75W/3.2A DIN-Rail 24VDC Industrial Power Supply (for Terminal Block)
41-136046-X	36W/3A 12VDC hardened power adapter with open wire in aluminum housing (for Terminal Block); (X) = 1: US, 2: EU, 3: UK, 4: AU, 5: JP, 6: SA
41-136044-X	36W/3A 12VDC hardened power adapter with latched DC Jack in aluminum housing (for DC Jack); (X) = 1: US, 2: EU, 3: UK, 4: AU, 5: JP, 6: SA

EX71000 Series

Hardened Managed 8-port 10/100BASE and 2-port Gigabit Ethernet Switch with SFP options



Overview

EtherWAN's EX71000 Series provides a Hardened Fully Managed 10-port switching platform combining high performance switching backbone with robust and secure management features required for mission critical and harsh environments where sustained connectivity is crucial.

The EX71000 Series is equipped with Ten 10/100BASE Fast Ethernet ports, in combination with up to Two Gigabit, Fixed Fiber, or SFP port options. Mountable on a DIN-rail. The EX71000 Series is equipped with EtherWAN's Alpha-Ring self-healing technology, providing less than 15ms fault recovery time making it ideal for applications intolerant to interruption.

Users are able to access management features such as; port security, IGMP snooping, VLANs, GARP protocols, LACP, via web browser, Telnet, SNMP, RMON, TFTP, and RS-232 console interfaces.

EtherWAN — "When Connectivity is Crucial."

Spotlight

• Versatile Connectivity

- Provides 8-port 10/100BASE-TX/FX/BX/SFP plus 2-port Gigabit-SX/LX/BX/SFP

• Hardened Grade

- Wide operating temperature range from -40°C to 75°C (-40°F to 167°F) for extreme environments
- Fanless and ruggedized housing

• Secure Remote Access

- IEEE802.1x, ACL (Access Control List), and RADIUS support

Software Features

Management

- Interface
 - CLI, Telnet and Web Browser
 - SNMP v1/v2c/v3
- Firmware and configuration upgrade and backup via TFTP
- Supports DHCP Server/Client
- RMON (Remote monitoring): group 1, 2, 3, 9
- Port mirroring: TX/RX and both
- NTP (Network Time Protocol) time synchronization
- IEEE802.1ab LLDP (Link Layer Discovery Protocol)

Security

- MAC address filtering
- Enable/disable port
- Storm control (broadcast and multicast types)
- IEEE802.1x LAN access control
- Remote authentication through RADIUS
- SSH for CLI and Telnet security
- SSL for web security
- Multi-level user account/password against unauthorized configuration
- System log (remote/local)

Quality of Service (QoS)

- Priority Queues: 4 queues per port
- Traffic classification based on IEEE802.1p CoS, DSCP, WRR
- (Weighted round robin) and strict mode
- Rate Limiting (Ingress/Egress)

Layer 2 Features

- Auto-negotiation for port speed and duplex mode
- Flow Control
 - IEEE802.3x full duplex mode
 - Back-Pressure half duplex mode
- Redundant Protocol
 - IEEE802.1D Spanning Tree Protocol (STP)
 - IEEE802.1w Rapid Spanning Tree Protocol (RSTP)
 - IEEE802.1s Multiple Spanning Tree Protocol (MSTP)
 - EtherWAN's Alpha-Ring network fault recovery (<15ms)
- VLANs
 - Port-based VLANs
 - IEEE802.1Q Tag VLANs (128 groups, 4096 VID)
 - GVRP (GARP VLAN Registration Protocol)
 - GMRP (GARP Multicast Registration Protocol)
- Link Aggregation
 - Static Trunk (2 groups, support MAC base)
 - IEEE802.3ad Link Aggregation Control Protocol
- IGMP Snooping
 - IGMP snooping v1/v2/v3

Performance

- Switching Capability: 6.8Gbps
- Packet Buffer Size: 2M bits
- MAC Address Table: 8192

Hardware Specifications

Technology

Standards

- IEEE802.3 10BASE-T
- IEEE802.3u 100BASE-TX/100BASE-FX
- IEEE802.3ab 1000BASE-T
- IEEE802.3z 1000BASE-SX/1000BASE-LX
- IEEE802.3x Full duplex and flow control
- IEEE802.1p QoS
- IEEE802.1Q Tag VLANs
- IEEE802.1w RSTP
- IEEE802.1x Port-based Network Access Control

Forward and Filtering Rate

- 14,880pps for 10Mbps
- 148,810pps for 100Mbps
- 1,488,100pps for 1000Mbps

Packet Buffer Memory

- 2M bits

Processing Type

- Store-and-Forward
- Auto Negotiation
- Half-duplex back-pressure and IEEE802.3x full-duplex flow control
- Auto MDI/MDIX

Address Table Size

- 8192 MAC addresses

Power

Input

- Redundant power inputs:
 - 12 - 48VDC (Terminal Block)
 - 12VDC (DC Jack)

Power Consumption

- 11W Max. 0.92A @ 12VDC, 0.46A @ 24VDC

Protection

- Overload current protection
- Reverse polarity protection

Mechanical

Casing

- Aluminum Case
- IP30

Dimensions

- 60mm (W) x 125mm (D) x 145mm (H)
(2.36" (W) x 4.92" (D) x 5.7" (H))

Weight

- 1.1Kg (2.42lbs.)

Installation

- DIN-Rail (Top hat type35mm), Rack or Wall mounting

Interface

Ethernet Port

- 10/100BASE-TX: 8, 6 or 4 port
- 100BASE-FX: 0 to 4 ports
- Gigabit: 0, 1 or 2 ports

Console Port

- Port: One DB9 RS-232 port

LED Indicators

- Per Unit: Power 1, Power 2, Power 3
- Per Port: Link/Activity, Speed

Alarm Contact

- One relay output with current 1A @ 24VDC

Environment

Operating Temperature

- -40°C to 75°C (-40°F to 167°F)
Tested @ -40°C to 85°C (-40°F to 185°F)

Storage Temperature

- -40°C to 85°C (-40°F to 185°F)

Ambient Relative Humidity

- 5% to 95% (non-condensing)

Regulatory Approvals

ISO

- Manufactured in an ISO9001 facility

Safety

UL508

EMI

FCC Part 15B, Class A

EN61000-6-4

EN55022

EN61000-3-2

EN61000-3-3

EMS

EN61000-6-2

- EN61000-4-2 (ESD Standards)
- EN61000-4-3 (Radiated RFI Standards)
- EN61000-4-4 (Burst Standards)
- EN61000-4-5 (Surge Standards)
- EN61000-4-6 (Induced RFI Standards)
- EN61000-4-8 (Magnetic Field Standards)

Environmental Test Compliance

IEC60068-2-6 Fc (Vibration Resistance)

IEC60068-2-27 Ea (Shock)

FED STD 101C Method 5007.1 (Free fall w/ package)

Industrial Compliance

NEMA TS2

EN50121-4

Application Diagram

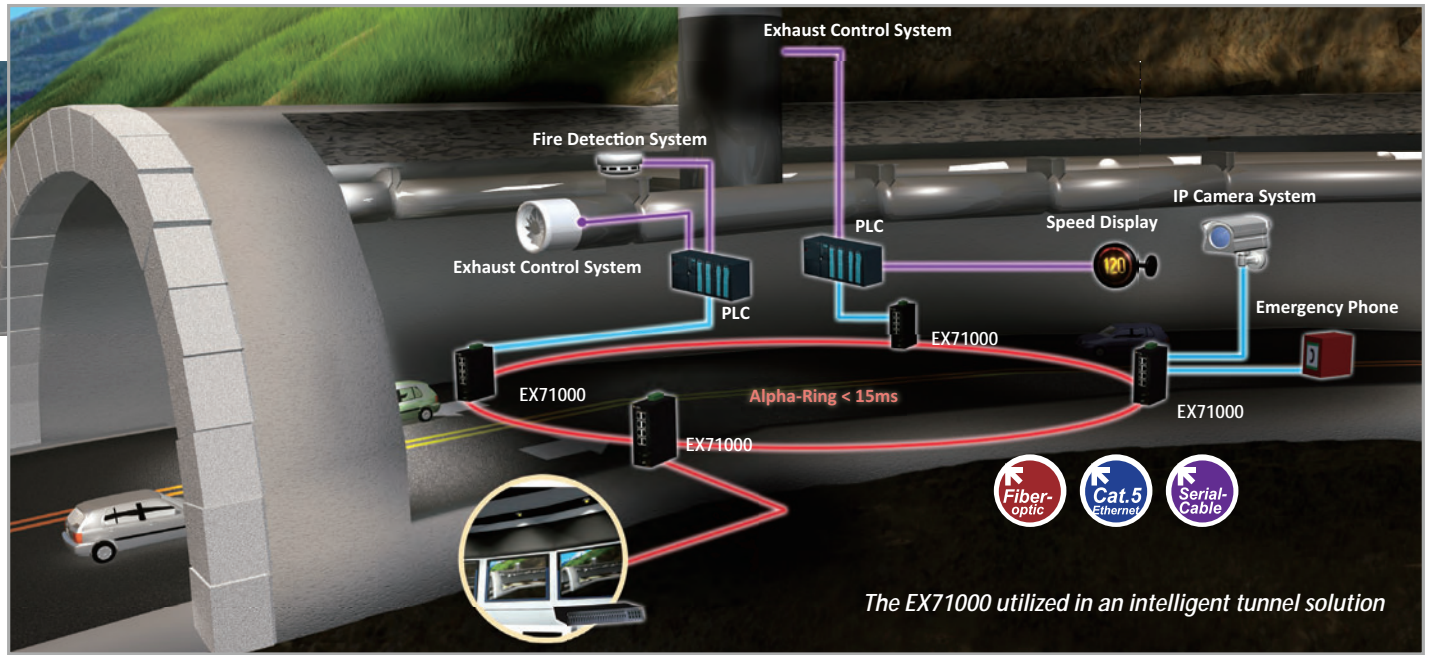

Dimensions

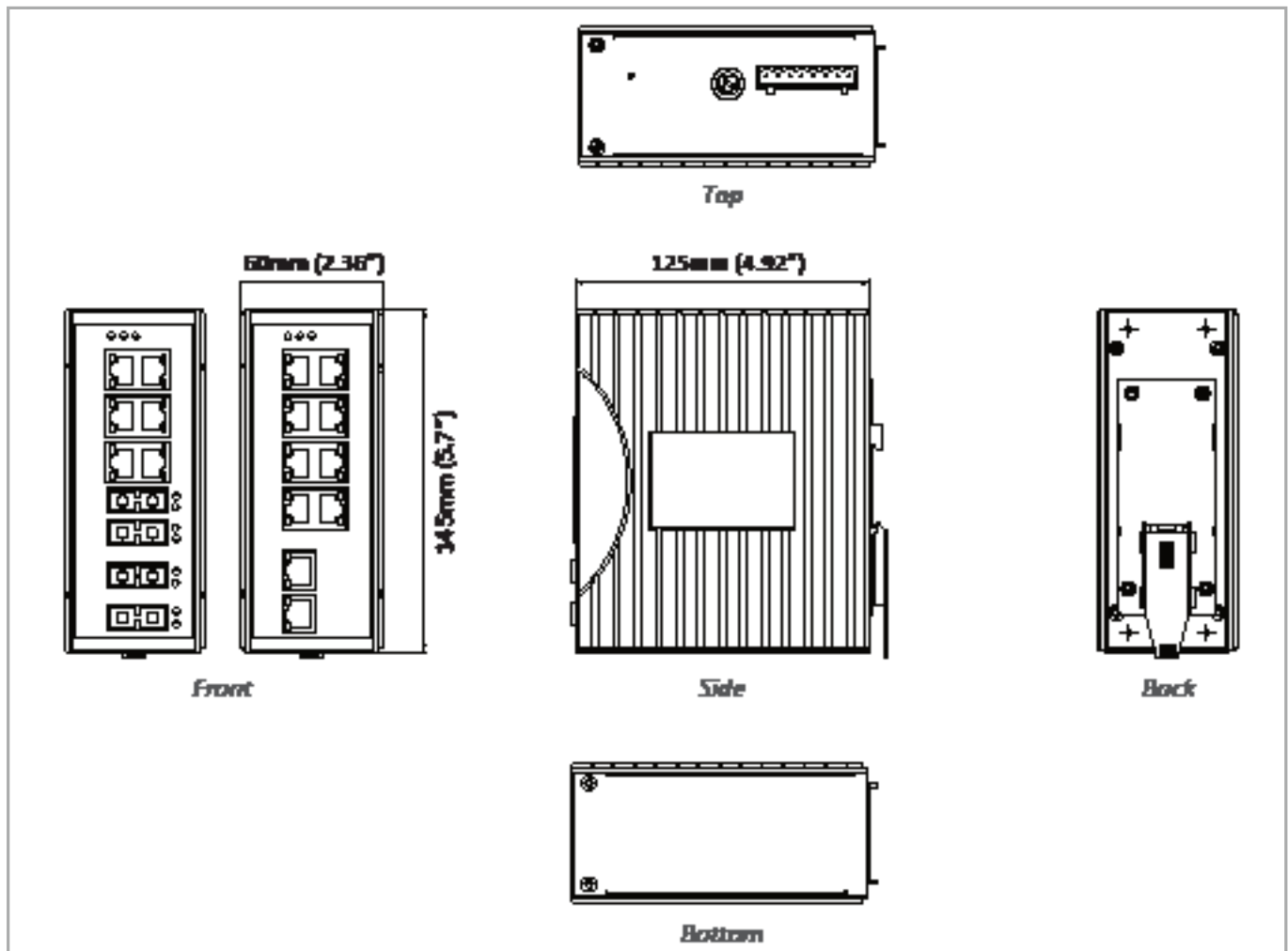

Ordering Information

Model

EX71800-00B	8-port 10/100BASE-TX Hardened Managed Ethernet Switch
EX71801-0YB	8-port 10/100BASE-TX + 1-port Gigabit Hardened Managed Ethernet Switch
EX71802-0YB	8-port 10/100BASE-TX + 2-port Gigabit Hardened Managed Ethernet Switch
EX71802-02B	8-port 10/100BASE-TX + 2-port 10/100/1000BASE-TX LAN Bypass
EX71610-X0B	6-port 10/100BASE-TX + 1-port 100BASE-FX Hardened Managed Ethernet Switch
EX71620-X0B	6-port 10/100BASE-TX + 2-port 100BASE-FX Hardened Managed Ethernet Switch
EX71621-XYB	6-port 10/100BASE-TX + 2-port 100BASE-FX + 1-port Gigabit Hardened Managed Ethernet Switch
EX71622-XYB	6-port 10/100BASE-TX + 2-port 100BASE-FX + 2-port Gigabit Hardened Managed Ethernet Switch
EX71420-X0B	4-port 10/100BASE-TX + 2-port 100BASE-FX Hardened Managed Ethernet Switch
EX71422-XYB	4-port 10/100BASE-TX + 2-port 100BASE-FX + 2-port Gigabit Hardened Managed Ethernet Switch
EX71440-X0B	4-port 10/100BASE-TX + 4-port 100BASE-FX Hardened Managed Ethernet Switch

* DIN-Rail mounting kit included

100FX Fiber Options (X)

1	Multi Mode (SC) - 2Km
2	Multi Mode (ST) - 2Km
6	Multi Mode (SC) WDM-TX:1310nm/RX:1550nm - 2Km
7	Multi Mode (SC) WDM-TX:1550nm/RX:1310nm - 2Km
8	Multi Mode (SC) WDM-TX:1310nm/RX:1550nm - 5Km
9	Multi Mode (SC) WDM-TX:1550nm/RX:1310nm - 5Km
A	Single Mode (SC) - 20Km
B	Single Mode (SC) - 40Km
H	Single Mode (ST) - 20Km
P	Single Mode (SC) WDM-TX:1310nm/RX:1550nm - 20Km
Q	Single Mode (SC) WDM-TX:1550nm/RX:1310nm - 20Km
R	Single Mode (SC) WDM-TX:1310nm/RX:1550nm - 40Km
S	Single Mode (SC) WDM-TX:1550nm/RX:1310nm - 40Km
V	100BASE SFP

Gigabit Port Options (Y)

1	10/100/1000BASE-TX
3	1000BASE-SX(SC) - 550m
4	1000BASE-SX (SC) - 2Km
5	1000BASE-SX (ST) - 550m
A	1000BASE-LX (SC) - 10Km
B	1000BASE-LX (SC) - 20Km
R	1000BASE-BX (SC) WDM-TX:1310nm/RX:1550nm - 20Km
S	1000BASE-BX (SC) WDM-TX: 1550nm/RX: 1310nm - 20Km
V	1000BASE SFP

Optional Accessories

KP-AA96-480	Panel mounting Kits
KR-BK71000	Rack mounting Kits
DR-30-24	30W/1.5A DIN-Rail 24VDC Industrial Power Supply (for Terminal Block)
DR-60--24	60W/2.5A DIN-Rail 24VDC Industrial Power Supply (for Terminal Block)
DR-75-24	75W/3.2A DIN-Rail 24VDC Industrial Power Supply (for Terminal Block)
DR-120-24	120W/5A DIN-Rail 24VDC Industrial Power Supply (for Terminal Block)
41-136046-X	36W/3A 12VDC hardened power adapter with open wire in aluminum housing (for Terminal Block) (X) = 1: US, 2: EU, 3: UK, 4: AU, 5: JP, 6: SA
41-136044-X	36W/3A 12VDC hardened power adapter with latched DC Jack in aluminum housing (for DC Jack) (X) = 1: US, 2: EU, 3: UK, 4: AU, 5: JP, 6: SA

EX74000 Series

Hardened Managed 6-port 10/100BASE (4 x PoE) with 2-port SFP (DDM) Gigabit combo Ethernet Switch



Overview

EtherWAN's EX74000 Series provides a hardened 8-port switching platform supporting IEEE802.3af+ Power over Ethernet, high performance switching with robust management features required for mission-critical and harsh environments where sustained connectivity is crucial.

The EX74000 Series is equipped with four 10/100BASE-TX PoE ports plus two 10/100BASE-TX/Gigabit SFP combo ports. The high-power PoE ports provide up to 30W/port with a total power budget of 120W, making the switch truly versatile for connecting with PoE Powered Devices (PD) with different bandwidth and power consumption requirements such as outdoor PTZ dome cameras, wireless access points, and way-side communication devices.

The EX74000 Series is equipped with EtherWAN's Alpha-Ring self-healing ring technology providing less than 15ms fault recovery time. Users are able to access management features such as port security, IGMP snooping, port-based VLAN, GARP protocols, link aggregation via web browser, telnet, SSH, SNMP, RMON, TFTP, and RS-232 console interfaces. With the hardened specifications, the EX74000 Series is designed to operate at -40°C to 75°C in harsh environments, where high ESD, shock, and vibration may be present.

EtherWAN — "When Connectivity is Crucial."

Spotlight

• Hardened Grade

- Wide operating temperature range from -40°C to 75°C (-40°F to 167°F) for extreme environments
- Fanless and ruggedized housing
- High shock and electric noise immunity
- Complies with UL508 safety requirements for industrial control devices

• Power over Ethernet

- Port 1 to 4 supports IEEE802.3af+ with 30W max.

• SFP Connectivity

- Provides two Gigabit-SFP combo ports for uplink

Software Features

Management

- Interface
 - CLI, Telnet and Web Browser
 - SNMP v1/v2c/v3
- Firmware and configuration upgrade and backup via TFTP
- Supports DHCP Server/Client
- RMON (Remote monitoring): group 1, 2, 3, 9
- Port mirroring: TX/RX and both
- SFP transceivers support Digital Diagnostics Monitoring (DDM)
- NTP (Network Time Protocol) time synchronization
- IEEE802.1ab LLDP (Link Layer Discovery Protocol)

Security

- MAC address filtering
- Enable/disable port
- Storm control (broadcast and multicast types)
- IEEE802.1x LAN access control
- Remote authentication through RADIUS
- SSH for CLI and Telnet security
- SSL for web security
- Multi-level user account/password against unauthorized configuration
- System log (remote/local)

Quality of Service (QoS)

- Priority Queues: 4 queues per port
- Traffic classification based on IEEE802.1p CoS, DSCP, WRR (Weighted round robin) and strict mode
- Rate Limiting (Ingress/Egress)

Layer 2 Features

- Auto-negotiation for port speed and duplex mode
- Flow Control
 - IEEE802.3x full duplex mode
 - Back-Pressure half duplex mode
- Redundant Protocol
 - IEEE802.1D Spanning Tree Protocol (STP)
 - IEEE802.1w Rapid Spanning Tree Protocol (RSTP)
 - IEEE802.1s Multiple Spanning Tree Protocol (MSTP)
 - EtherWAN's Alpha-Ring network fault recovery (<15ms)
- VLANs
 - Port-based VLANs
 - IEEE802.1Q Tag VLANs (128 groups, 4096 VID)
 - GVRP (GARP VLAN Registration Protocol)
 - GMRP (GARP Multicast Registration Protocol)
- Link Aggregation
 - Static Trunk (2 groups, support MAC base)
 - IEEE802.3ad Link Aggregation Control Protocol
- IGMP Snooping
 - IGMP snooping v1/v2/v3

Performance

- Switching Capability: 5.2Gbps
- Packet Buffer Size: 2M bits
- MAC Address Table: 8192

Hardware Specifications

Technology

Standards

- IEEE802.3 10BASE-T
- IEEE802.3u 100BASE-TX/100BASE-FX
- IEEE802.3ab 1000BASE-T
- IEEE802.3z 1000BASE-SX/1000BASE-LX
- IEEE802.3x Full duplex and flow control
- IEEE802.1p QoS
- IEEE802.1Q Tag VLANs
- IEEE802.1w RSTP
- IEEE802.1x Port-based Network Access Control
- IEEE802.3af Power over Ethernet (PoE)

Forward and Filtering Rate

- 14,880pps for 10Mbps
- 148,810pps for 100Mbps
- 1,488,100pps for 1000Mbps

Packet Buffer Memory

- 2M bits

Processing Type

- Store-and-Forward
- Auto Negotiation
- Half-duplex back-pressure and IEEE802.3x full-duplex flow control
- Auto MDI/MDIX

Address Table Size

- 8192 MAC addresses

Power

Input Voltage

- Terminal Block: 47 to 57VDC

Power Consumption

- Device: Max. 17.7W (without PoE)
- PoE power budget (depends on power input): 120W Max.

PoE Power Output

- Port 1 to 4
- IEEE802.3af: up to 15.4W/port, 47 - 57VDC
- IEEE802.3af+: up to 30W/port, 50 - 57VDC

Protection

- Overload current protection
- Reverse polarity protection

Mechanical

Casing

- Metal Case
- IP30

Dimensions

- 200mm (W) x 134mm (D) x 50mm (H)
(7.87" (W) x 5.2" (D) x 1.97" (H))

Weight

- 1.5Kg (7.7lbs.)

Installation

- Panel or Rack mounting

Interface

Ethernet Port

- 10/100BASE-TX: 6 ports
- Gigabit SFP (DDM): 2 ports

Console Port

- Port: One DB9 RS-232 port

LED Indicators

- Per Unit: Power Status
- Per port 10/100TX PoE (Orange)
- Per port 10/100TX, 100FX: Link/Activity (Green)
- Per port Gigabit/SFP: Link/Activity (Green)

Environment

Operating Temperature

- -40°C to 75°C (-40°F to 167°F)
Tested @ -40°C to 85°C (-40°F to 185°F)

Storage Temperature

- -45°C to 85°C (-49°F to 185°F)

Ambient Relative Humidity

- 5% to 95% (non-condensing)

Regulatory Approvals

ISO

- Manufactured in an ISO9001 facility

EMI

FCC Part 15B, Class A

EN61000-6-4

EN55022

EN61000-3-2

EN61000-3-3

EMS

EN61000-6-2

- EN61000-4-2 (ESD Standards)
- EN61000-4-3 (Radiated RFI Standards)
- EN61000-4-4 (Burst Standards)
- EN61000-4-5 (Surge Standards)
- EN61000-4-6 (Induced RFI Standards)
- EN61000-4-8 (Magnetic Field Standards)

Environmental Test Compliance

IEC60068-2-6 Fc (Vibration)

IEC60068-2-27 Ea (Shock)

IEC60068-2-32 Ed (Free fall)

Industrial Compliance

NEMA TS2

Application Diagram

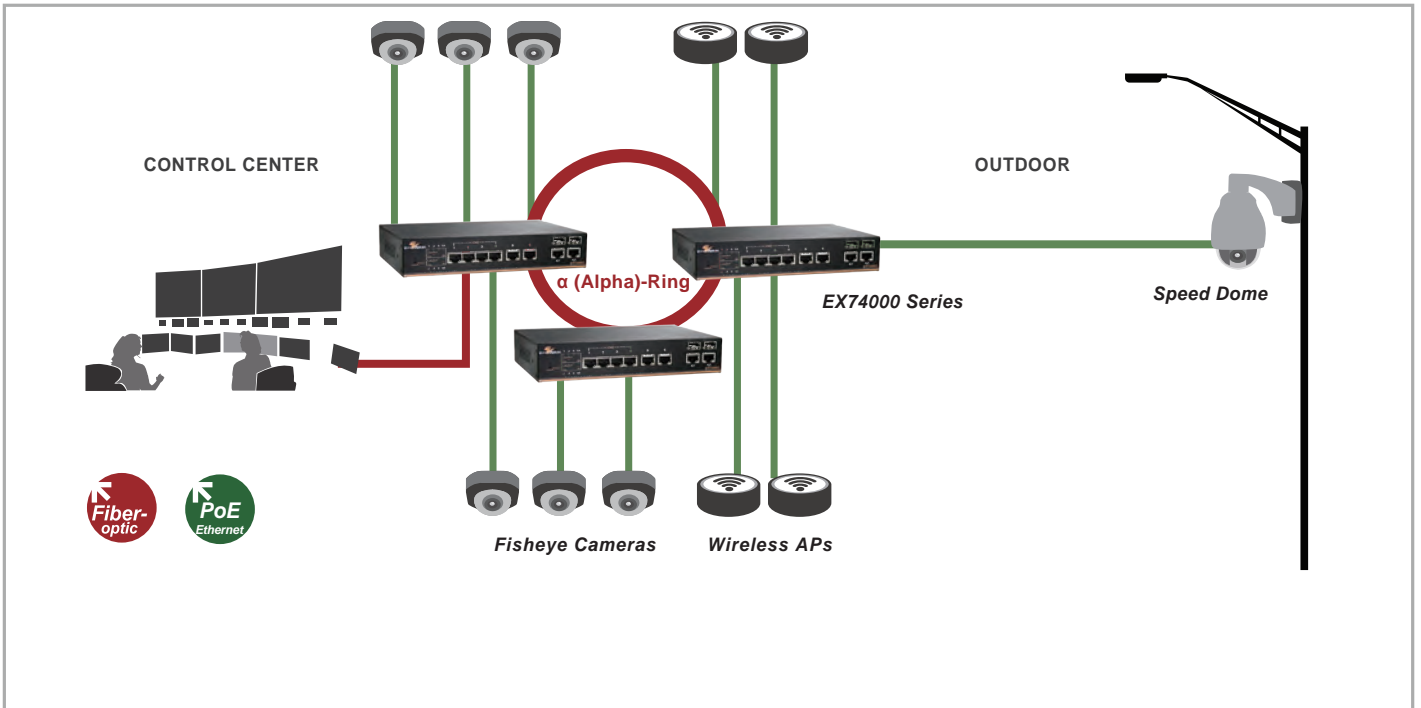

Dimensions

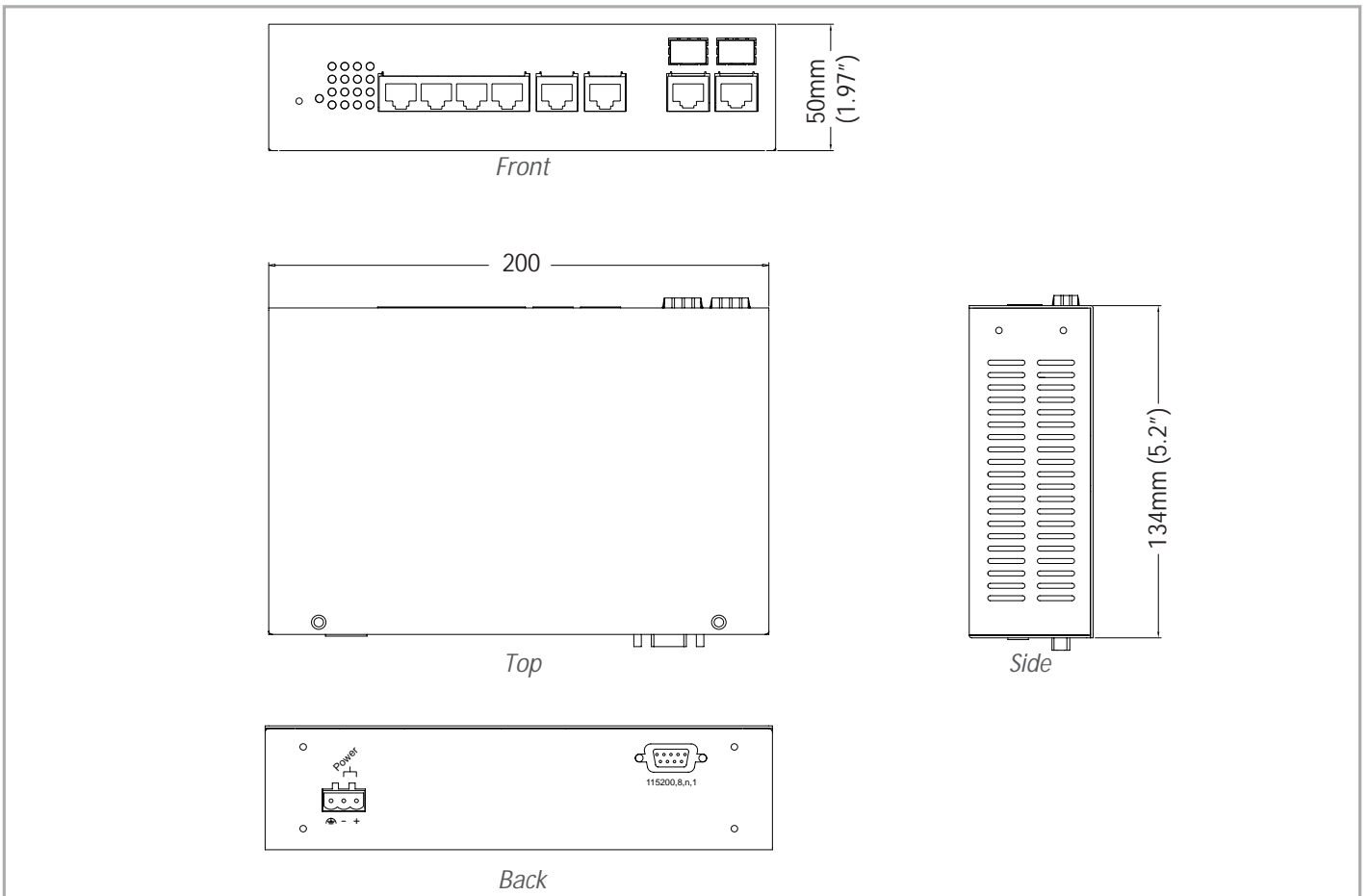

Ordering Information

Model

EX74X62-0VT	6-port 10/100BASE-TX + 2-port Gigabit SFP (DDM) combo Hardened Managed Ethernet Switch (Terminal Block Input)
-------------	---

PoE Options (X)

0	Non-PoE
1	15.4W (4-port 802.3af)
2	30W (4-port 802.3af+ 30W)

Optional Accessories

KP-BK6212	Panel mounting kit
DD-85-48	85W/1.78A 48VDC Industrial Power Supply (<i>for 15.4W 802.3af</i>)
DR-75-48	75W/1.6A DIN-Rail 48VDC Industrial Power Supply (<i>for 15.4W 802.3af</i>)
DR-120-48	120W/2.5A DIN-Rail 48VDC Industrial Power Supply (<i>for 15.4W 802.3af</i>)
SDR-240-48	240W/5A DIN-Rail 48VDC Industrial Power Supply (<i>for 30W 802.3af+</i>)

EX48000 Series

Hardened Web-Smart 5-port 10/100BASE PoE (4 x PoE)
Ethernet Switch



Overview

EtherWAN's EX48000 Series provides a hardened 5-port switching platform supporting IEEE802.3af+ Power over Ethernet, high performance switching with robust management features required for mission-critical and harsh environments where sustained connectivity is crucial.

The EX48000 Series is equipped with four 10/100BASE-TX PoE ports, in combination with one 100FX Fiber option. The IEEE802.3af+ PoE ports provide up to 30W/port with a total power budget of 120W, making the switch truly versatile for connecting with PoE Powered Devices (PD) with different bandwidth and power consumption requirements.

Users are able to access management features such as QoS based on 802.1p, DSCP, and IP precedence. With the hardened specifications, the EX48000 Series is designed to operate at -40°C to 75°C in harsh environments where high ESD, shock and vibration may be present.

EtherWAN — "When Connectivity is Crucial."

Spotlight

• Hardened Grade

- Supports -40°C to 75°C (-40°F to 167°F) operating temperature

• PoE Connectivity

- Port 1 to 4 supports IEEE802.3af+ Power over Ethernet

• Fiber Connectivity

- Up to one 100BASE-FX port with SC or ST option

• Web-Managed Interface

- Comprehensive QoS based on 802.1p, DSCP, and IP precedence

Hardware Specifications

Technology

Standards

- IEEE802.3 10BASE-T
- IEEE802.3u 100BASE-TX/100BASE-FX
- IEEE802.3x Full duplex and flow control
- IEEE802.3af+ Power over Ethernet (PoE)

Forward and Filtering Rate

- 14,880pps for 10Mbps
- 148,810pps for 100Mbps

Packet Buffer Memory

- 512K bits

Processing Type

- Store-and-Forward
- Auto Negotiation
- Half-duplex back-pressure and IEEE802.3x full-duplex flow control
- Auto MDI/MDIX

Address Table Size

- 1024 MAC addresses

Power

Input

- Redundant power inputs:
Terminal Block: 47 - 57VDC
DC Jack: 47 - 57VDC

Power Consumption

- Device: Max. 10W (without PoE)
- PoE power budget (depends on power input): 120W Max.

PoE Power Output

- Port 1 to 4
- IEEE802.3af+: up to 30W/port, 47 - 57VDC, 600mA Max.

Protection

- Reverse polarity protection
- Overload current protection

Mechanical

Casing

- Metal case
- IP30

Dimensions

- 200mm (W) x 134.3mm (D) x 35mm (H)
(7.87" (W) x 5.29" (D) x 1.38" (H))

Weight

- 0.8Kg (1.76lbs.)

Installation

- Desktop, Wall, or DIN-Rail mounting

Interface

Ethernet Ports

- 10/100BASE-TX: 5 or 4 ports
- 100BASE-FX: 0 or 1 ports

LED Indicators

- Per Unit: Power 1 (Green)
Power 2 (Green)
Power 3 (Green)
Fault (Red)
- Per Port: Link/Activity (Green)

Alarm Contact

- One relay output with current 1A @ 250VAC

Environment

Operating Temperature

- -40°C to 75°C (-40°F to 167°F)
Tested @ -40°C to 85°C (-40°F to 185°F)

Storage Temperature

- -40°C to 85°C (-40°F to 185°F)

Ambient Relative Humidity

- 5% to 95% (non-condensing)

Regulatory Approvals

ISO

- Manufactured in an ISO9001 facility

EMI

FCC Part 15B, Class A

EN61000-6-4

EN55022

EN61000-3-2

EN61000-3-3

EMS

EN61000-6-2

- EN61000-4-2 (ESD Standards)
- EN61000-4-3 (Radiated FRI Standards)
- EN61000-4-4 (Burst Standards)
- EN61000-4-5 (Surge Standards)
- EN61000-4-6 (Induced RFI Standards)
- EN61000-4-8 (Magnetic Field Standards)

Environmental Test Compliance

IEC60068-2-6 Fc (Vibration)

IEC60068-2-27 Ea (Shock)

FED STD 101C Method 5007.1 (Free fall w/ package)

Industrial Compliance

NEMA TS2

Dimensions

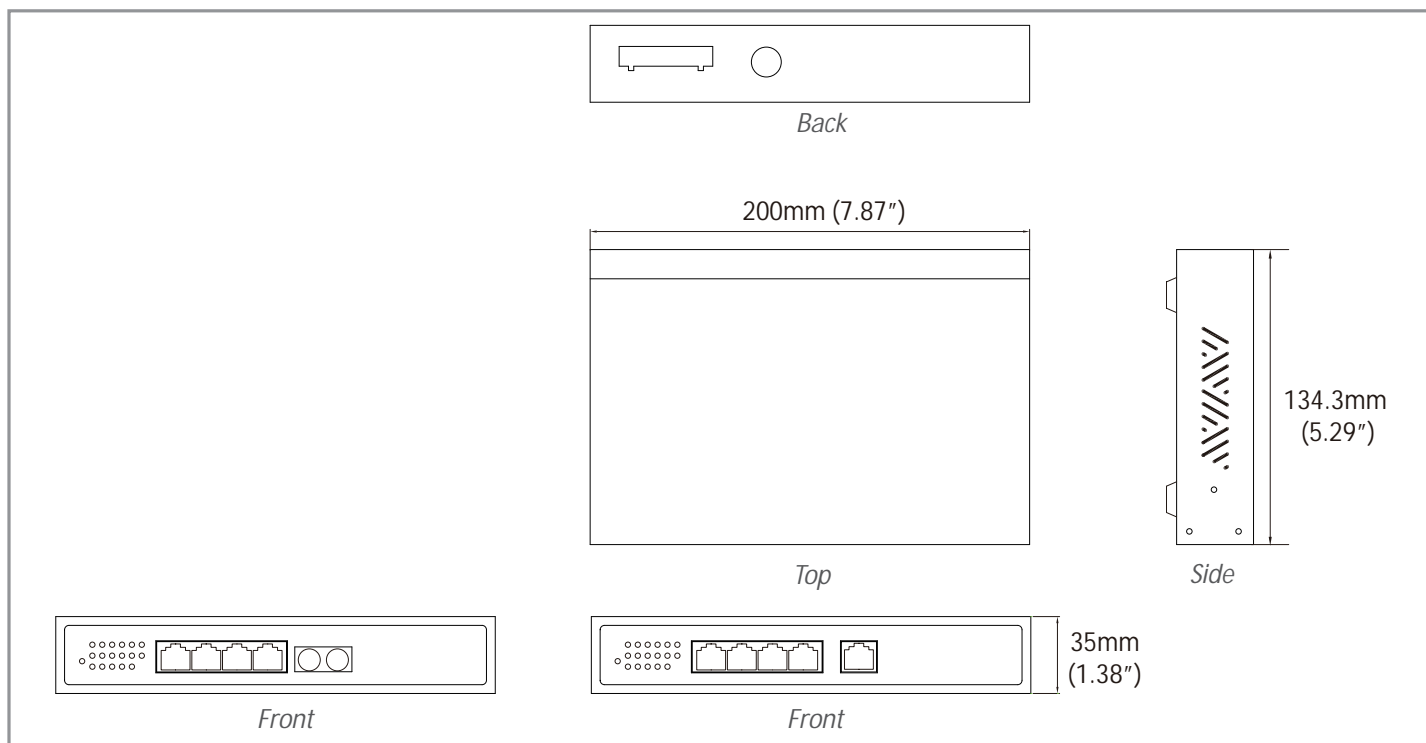

Ordering Information

Model

EX48050-00B	Hardened Web-smart 5-port 10/100BASE-TX PoE Ethernet Switch
EX48041-X0B	Hardened Web-smart 4-port 10/100BASE-TX + 1-port 100BASE-FX PoE Ethernet Switch

* DIN-Rail mounting kit included

100FX Fiber Options (X)

1	Multi Mode (SC) - 2Km
2	Multi Mode (ST) - 2Km
6	Multi Mode (SC) WDM-TX:1310nm/RX:1550nm - 2Km
7	Multi Mode (SC) WDM-TX:1550nm/RX:1310nm - 2Km
8	Multi Mode (SC) WDM-TX:1310nm/RX:1550nm - 5Km
9	Multi Mode (SC) WDM-TX:1550nm/RX:1310nm - 5Km
A	Single Mode (SC) - 20Km
B	Single Mode (SC) - 40Km
H	Single Mode (ST) - 20Km
P	Single Mode (SC) WDM-TX:1310nm/RX:1550nm - 20Km
Q	Single Mode (SC) WDM-TX:1550nm/RX:1310nm - 20Km
R	Single Mode (SC) WDM-TX:1310nm/RX:1550nm - 40Km
S	Single Mode (SC) WDM-TX:1550nm/RX:1310nm - 40Km

*More 100FX Fiber options also available upon request.

Optional Accessories

KD-AA78000X	DIN-Rail Mounting Kit
SDR-240-48	240W/5A DIN-Rail 48VDC Industrial Power Supply
SDR-480-48	480W/10A DIN-Rail 48VDC Industrial Power Supply

EX46100 Series

Hardened Web-smart 8-port 10/100BASE High Power PoE (4 x PoE) Ethernet Switch



Overview

EtherWAN's EX46100 Series provides a hardened 8-port switching platform supporting IEEE802.3af+ Power over Ethernet, high performance switching with robust features required for mission-critical and harsh environments where sustained connectivity is crucial.

The EX46100 Series is equipped with 4 10/100BASE-TX PoE ports, in combination with two 100FX Fiber options.

The IEEE802.3af+ PoE ports provide up to 30W/port with a total power budget of 120W, making the switch truly versatile for connecting with PoE Powered Devices (PD) with different bandwidth and power consumption requirements such as outdoor PTZ dome cameras, wireless access points, and way-side communication devices.

Users are able to access management features such as QoS based on 802.1p, DSCP, and IP precedence. With the hardened specifications, the EX46100 Series is designed to operate at -40°C to 75°C in harsh environments where high ESD, shock and vibration may be present.

Spotlight

- **Hardened Grade**
 - Supports -40°C to 75°C (-40°F to 167°F) operating temperature
- **PoE Connectivity**
 - Port 1 to 4 supports IEEE802.3af+ Power over Ethernet
- **Fiber Connectivity**
 - Up to two 100BASE-FX ports with SC and ST options
- **Web-Managed Interface**
 - Comprehensive QoS based on 802.1p, DSCP, and IP precedence

Hardware Specifications

Technology

Standards

- IEEE802.3 10BASE-T
- IEEE802.3u 100BASE-TX/100BASE-FX
- IEEE802.3x Full duplex and flow control
- IEEE802.3af+ Power over Ethernet (PoE)

Forward and Filtering Rate

- 14,880pps for 10Mbps
- 148,810pps for 100Mbps

Packet Buffer Memory

- 1M bits

Processing Type

- Store-and-Forward
- Auto Negotiation
- Half-duplex back-pressure and IEEE802.3x full-duplex flow control
- Auto MDI/MDIX

Address Table Size

- 1024 MAC addresses

Power

Input

- Redundant power inputs:
Terminal Block: 47 - 57VDC
DC Jack: 47 - 57VDC

Power Consumption

- Device: Max. 10W (without PoE)
- PoE power budget (depends on power input): 120W Max.

PoE Power Output

- Port 1 to 4
- IEEE802.3af+: up to 30W/port, 47 - 57VDC, 600mA Max.

Protection

- Reverse polarity protection
- Overload current protection

Mechanical

Casing

- Aluminum case
- IP30

Dimensions

- 68mm (W) x 110mm (D) x 135mm (H)
(2.68" (W) x 4.33" (D) x 5.31" (H))

Weight

- 1Kg (2.2lbs.)

Installation

- DIN-Rail (Top hat type 35mm), Panel or Rack mounting

Interface

Ethernet Ports

- 10/100BASE-TX: 8, 7 or 6 ports
- 100BASE-FX: 0, 1 or 2 ports

LED Indicators

- Per Unit: Power 1 (Green)
Power 2 (Green)
Power 3 (Green)
- Per Port: Link/Act (Green)
- Per PoE port: PoE Status (Amber)

Alarm Contact

- One relay output with current 1A @ 24VDC

Environment

Operating Temperature

- -40°C to 75°C (-40°F to 167°F)
Tested @ -40°C to 85°C (-40°F to 185°F)

Web-smart Function Operating Temperature

- -20°C to 75°C (-4°F to 167°F)

Storage Temperature

- -40°C to 85°C (-40°F to 185°F)

Ambient Relative Humidity

- 5% to 95% (non-condensing)

Regulatory Approvals

ISO

- Manufactured in an ISO9001 facility

EMI

FCC Part 15B, Class A

EN61000-6-4

EN55022 Class A

EMS

EN61000-6-2

- EN61000-4-2 (ESD Standards)
- EN61000-4-3 (Radiated FRI Standards)
- EN61000-4-4 (Burst Standards)
- EN61000-4-5 (Surge Standards)
- EN61000-4-6 (Induced RFI Standards)
- EN61000-4-8 (Magnetic Field Standards)

Environmental Test Compliance

IEC60068-2-6 Fc (Vibration)

IEC60068-2-27 Ea (Shock)

FED STD 101C Method 5007.1 (Free fall w/ package)

Industrial Compliance

NEMA TS2

Dimensions

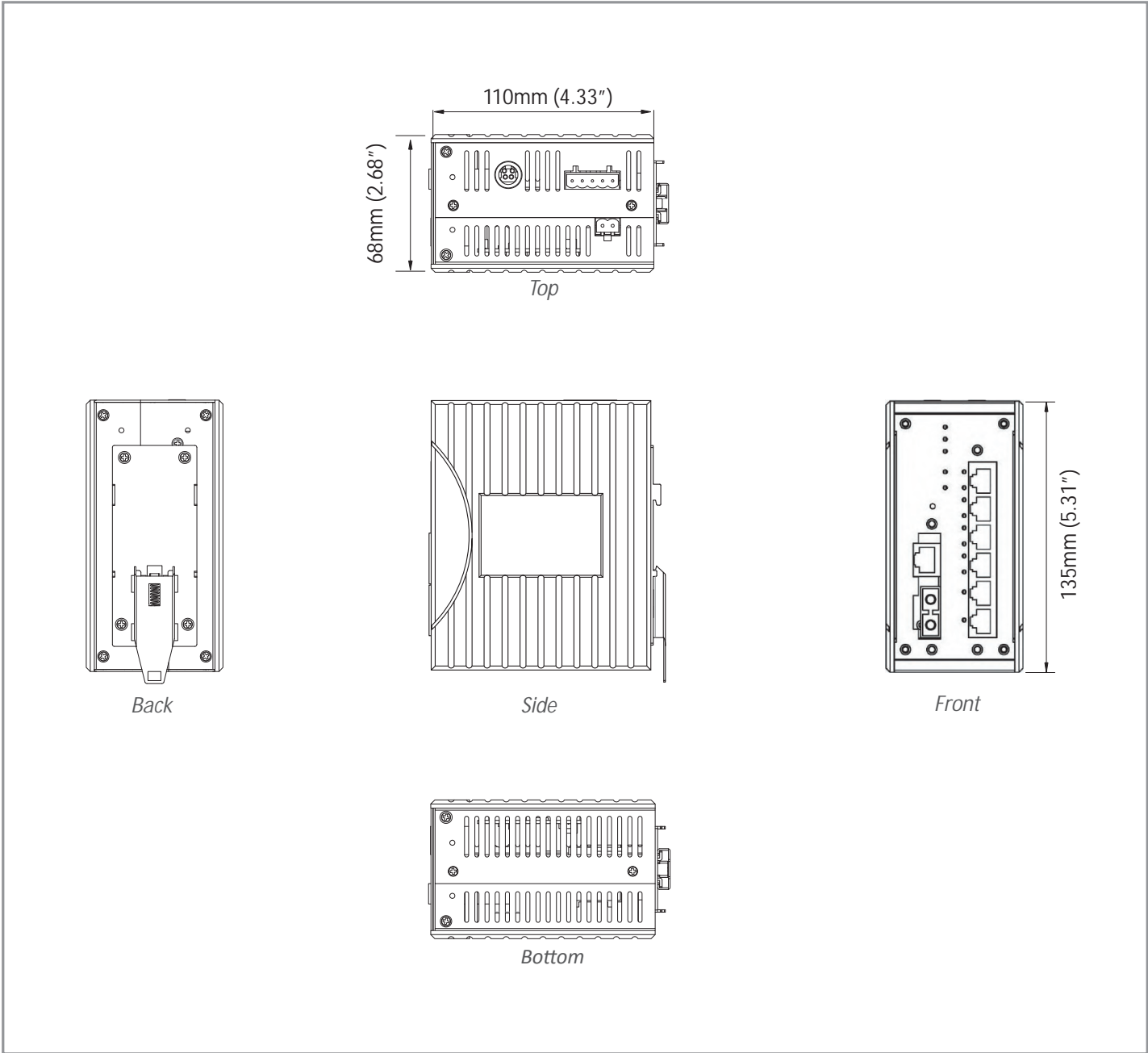

Ordering Information

Model

EX46180-00B	Hardened Web-smart 8-port 10/100BASE-TX PoE+ Ethernet Switch
EX46171-X0B	Hardened Web-smart 7-port 10/100BASE-TX + 1-port 100BASE-FX PoE+ Ethernet Switch
EX46162-X0B	Hardened Web-smart 6-port 10/100BASE-TX + 2-port 100BASE-FX PoE+ Ethernet Switch

* DIN-Rail mounting kit included

100FX Fiber Options (X)

1	Multi Mode (SC) - 2Km
2	Multi Mode (ST) - 2Km
6	Multi Mode (SC) WDM-TX:1310nm/RX:1550nm - 2Km
7	Multi Mode (SC) WDM-TX:1550nm/RX:1310nm - 2Km
8	Multi Mode (SC) WDM-TX:1310nm/RX:1550nm - 5Km
9	Multi Mode (SC) WDM-TX:1550nm/RX:1310nm - 5Km
A	Single Mode (SC) - 20Km
B	Single Mode (SC) - 40Km
H	Single Mode (ST) - 20Km
P	Single Mode (SC) WDM-TX:1310nm/RX:1550nm - 20Km
Q	Single Mode (SC) WDM-TX:1550nm/RX:1310nm - 20Km
R	Single Mode (SC) WDM-TX:1310nm/RX:1550nm - 40Km
S	Single Mode (SC) WDM-TX:1550nm/RX:1310nm - 40Km

*More 100FX Fiber options also available upon request.

Optional Accessories

KP-AA96-480	Panel Mounting Kit
KR-BK-43-400	Rack Mounting Kit
DR-120-48	120W/2.5A DIN-Rail 48VDC Industrial Power Supply
SDR-240-48	240W/5A DIN-Rail 48VDC Industrial Power Supply

EX49000 Series

Hardened Web-smart 16-port 10/100BASE PoE and 2-port Gigabit Ethernet Switch



Overview

EtherWAN's EX49000 Series provides a hardened 18-port switching platform supporting IEEE802.3at Power over Ethernet, high performance switching with robust features required for mission-critical and harsh environments where sustained connectivity is crucial.

The EX49000 Series is equipped with 16 10/100BASE-TX PoE ports, in combination with two Gigabit SX/LX/BX/WDM Fiber or SFP options.

The IEEE802.3at PoE ports provide up to 30W/port with a total power budget of 480W, making the switch truly versatile for connecting with PoE Powered Devices (PD) with different bandwidth and power consumption requirements such as outdoor PTZ dome cameras, wireless access points, and way-side communication devices.

Users are able to access management features such as QoS based on 802.1p, DSCP, and IP precedence. With the hardened specifications, the EX49000 Series is designed to operate at -40°C to 75°C in harsh environments, where high ESD, shock, and vibration may be present.

Spotlight

• Hardened Grade

- Supports -40°C to 75°C (-40°F to 167°F) operating temperature

• PoE Connectivity

- Port 1 to 16 supports IEEE802.3at Power over Ethernet

• Fiber Connectivity

- Up to two 1000BASE-SX ports with SC, ST and SFP options

• Web-Managed Interface

- Comprehensive QoS based on 802.1p, DSCP, and IP precedence

Hardware Specifications

Technology

Standards

- IEEE802.3 10BASE-T
- IEEE802.3u 100BASE-TX/100BASE-FX
- IEEE802.3x Full duplex and flow control
- IEEE802.3z 1000BASE-SX/LX
- IEEE802.3ab 1000BASE-T
- IEEE802.3af/at Power over Ethernet (PoE)

Forward and Filtering Rate

- 14,880pps for 10Mbps
- 148,810pps for 100Mbps
- 1,488,100pps for 1000Mbps

Packet Buffer Memory

- 2.25M bits

Processing Type

- Store-and-Forward
- Auto Negotiation
- Half-duplex back-pressure and IEEE802.3x full-duplex flow control
- Auto MDI/MDIX

Address Table Size

- 4096 MAC addresses

Power

Input Voltage

- 47 - 57VDC

Power Consumption

- Device: Max. 15W (without PoE)
- PoE power budget (depends on power input): 480W Max.

PoE Power Output

- IEEE 802.3at: up to 30W/port, 50 - 57VDC, 600mA Max.

Protection

- Reverse polarity protection

Mechanical

Casing

- Metal case

Dimensions

- 442mm (W) x 205mm (D) x 44.2mm (H)
(17.40" (W) x 8.07" (D) x 1.73" (H))

Weight

- 3Kg (6.61lbs.)

Installation

- Rack mounting

Interface

Ethernet Ports

- 10/100 BASE: 16 ports
- Gigabit: 2 ports

LED Indicators

- Per Unit: Power 1 (Green)
Power 2 (Green)
Fault (Red)
- Per Port: Link/Activity (Green)
Speed (Amber)
- Per PoE Port: PoE Status (Amber)

Environment

Operating Temperature

- -40°C to 75°C (-40°F to 167°F)

Storage Temperature

- -40°C to 85°C (-40°F to 185°F)

Ambient Relative Humidity

- 5% to 95% (non-condensing)

Regulatory Approvals

ISO

- Manufactured in an ISO9001 facility

EMI

FCC Part 15B, Class A

EN61000-6-4

EN55022 Class A

EMS

EN61000-6-2

- EN61000-4-2 (ESD Standards)
- EN61000-4-3 (Radiated FRI Standards)
- EN61000-4-4 (Burst Standards)
- EN61000-4-5 (Surge Standards)
- EN61000-4-6 (Induced RFI Standards)
- EN61000-4-8 (Magnetic Field Standards)

Environmental Test Compliance

IEC60068-2-6 Fc (Vibration)

IEC60068-2-27 Ea (Shock)

FED STD 101C Method 5007.1 (Free fall w/ package)

Industrial Compliance

NEMA TS2

Dimensions

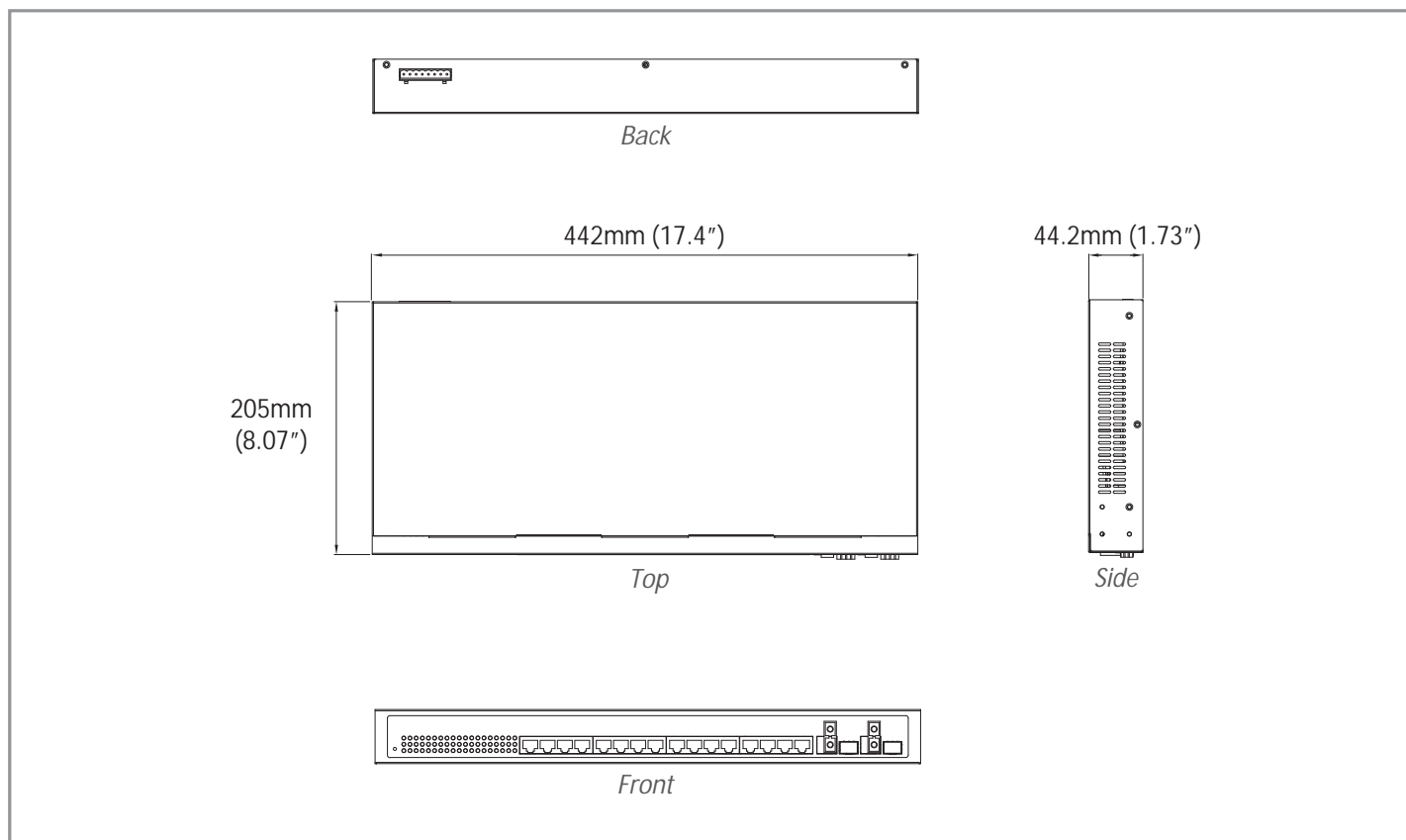

Ordering Information

Model

EX49162-0XT	Hardened Web-smart 16-port 10/100BASE-TX + 2-port Gigabit PoE Ethernet Switch
-------------	---

* Rack mounting kit included

Gigabit Port Options (X)

1	10/100/1000BASE-TX
3	1000BASE-SX(SC) - 550m
4	1000BASE-SX (SC) - 2Km
5	1000BASE-SX (ST) - 550m
A	1000BASE-LX (SC) - 10Km
B	1000BASE-LX (SC) - 20Km
R	1000BASE-BX (SC) WDM-TX:1310nm/RX:1550nm - 20Km
S	1000BASE-BX (SC) WDM-TX:1550nm/RX: 1310nm - 20Km
V	1000BASE SFP Combo with 10/100/1000BAST-T

*More 100FX Fiber options also available upon request.

Accessories

SDR-480-48	480W/10A DIN-Rail 48VDC Industrial Power Supply
------------	---

EX49000A Series

Hardened Unmanaged 16-port 10/100BASE PoE and 2-port Gigabit Ethernet Switch



Overview

EtherWAN's EX49000A Series provides a hardened 18-port switching platform supporting IEEE802.3at Power over Ethernet, high performance switching with robust features required for mission-critical and harsh environments where sustained connectivity is crucial.

The EX49000A Series is equipped with 16 10/100BASE-TX PoE ports, in combination with two Gigabit SX/LX/BX/WDM Fiber or SFP options.

The IEEE802.3at PoE ports provide up to 30W/port with a total power budget of 480W, making the switch truly versatile for connecting with PoE Powered Devices (PD) with different bandwidth and power consumption requirements such as outdoor PTZ dome cameras, wireless access points, and way-side communication devices.

With the hardened specifications, the EX49000A Series is designed to operate at -40°C to 75°C in harsh environments, where high ESD, shock, and vibration may be present.

Spotlight

- **Hardened Grade**
 - Supports -40°C to 75°C (-40°F to 167°F) operating temperature
- **PoE Connectivity**
 - Port 1 to 16 supports IEEE802.3at Power over Ethernet
- **Fiber Connectivity**
 - Up to two 1000BASE-SX ports with SC, ST and SFP options

Hardware Specifications

Technology

Standards

- IEEE802.3 10BASE-T
- IEEE802.3u 100BASE-TX/100BASE-FX
- IEEE802.3x full duplex and flow control
- IEEE802.3z 1000BASE-SX/LX
- IEEE802.3ab 1000BASE-T
- IEEE802.3af/at Power over Ethernet (PoE)

Forward and Filtering Rate

- 14,880pps for 10Mbps
- 148,810pps for 100Mbps
- 1,488,100pps for 1000Mbps

Packet Buffer Memory

- 2.25M bits

Processing Type

- Store-and-Forward
- Auto Negotiation
- Half-duplex back-pressure and IEEE802.3x full-duplex flow control
- Auto MDI/MDIX

Address Table Size

- 4096 MAC addresses

Power

Input

- 47 - 57VDC

Power Consumption

- Device: Max. 15W (without PoE)
- PoE power budget (depends on power input): 480W Max.

PoE Power Output

- IEEE 802.3at: up to 30W/port, 50 - 57VDC, 600mA Max.

Protection

- Reverse polarity protection

Mechanical

Casing

- Metal case

Dimensions

- 442mm (W) x 205mm (D) x 44.2mm (H)
(17.40" (W) x 8.07" (D) x 1.73" (H))

Weight

- 3Kg (6.61lbs.)

Installation

- Rack mounting

Interface

Ethernet Ports

- 10/100 BASE: 16 ports
- Gigabit: 2 ports

LED Indicators

- Per Unit: Power 1 (Green)
Power 2 (Green)
Fault (Red)
- Per Port: Link/Activity (Green)
Speed (Amber)
- Per PoE Port: PoE Status (Amber)

Environment

Operating Temperature

- -40°C to 75°C (-40°F to 167°F)

Storage Temperature

- -40°C to 85°C (-40°F to 185°F)

Ambient Relative Humidity

- 5% to 95% (non-condensing)

Regulatory Approvals

ISO

- Manufactured in an ISO9001 facility

EMI

FCC Part 15B, Class A

EN61000-6-4

EN55022 Class A

EMS

EN61000-6-2

- EN61000-4-2 (ESD Standards)
- EN61000-4-3 (Radiated FRI Standards)
- EN61000-4-4 (Burst Standards)
- EN61000-4-5 (Surge Standards)
- EN61000-4-6 (Induced RFI Standards)
- EN61000-4-8 (Magnetic Field Standards)

Environmental Test Compliance

IEC60068-2-6 Fc (Vibration)

IEC60068-2-27 Ea (Shock)

FED STD 101C Method 5007.1 (Free fall w/ package)

Industrial Compliance

NEMA TS2

Dimensions

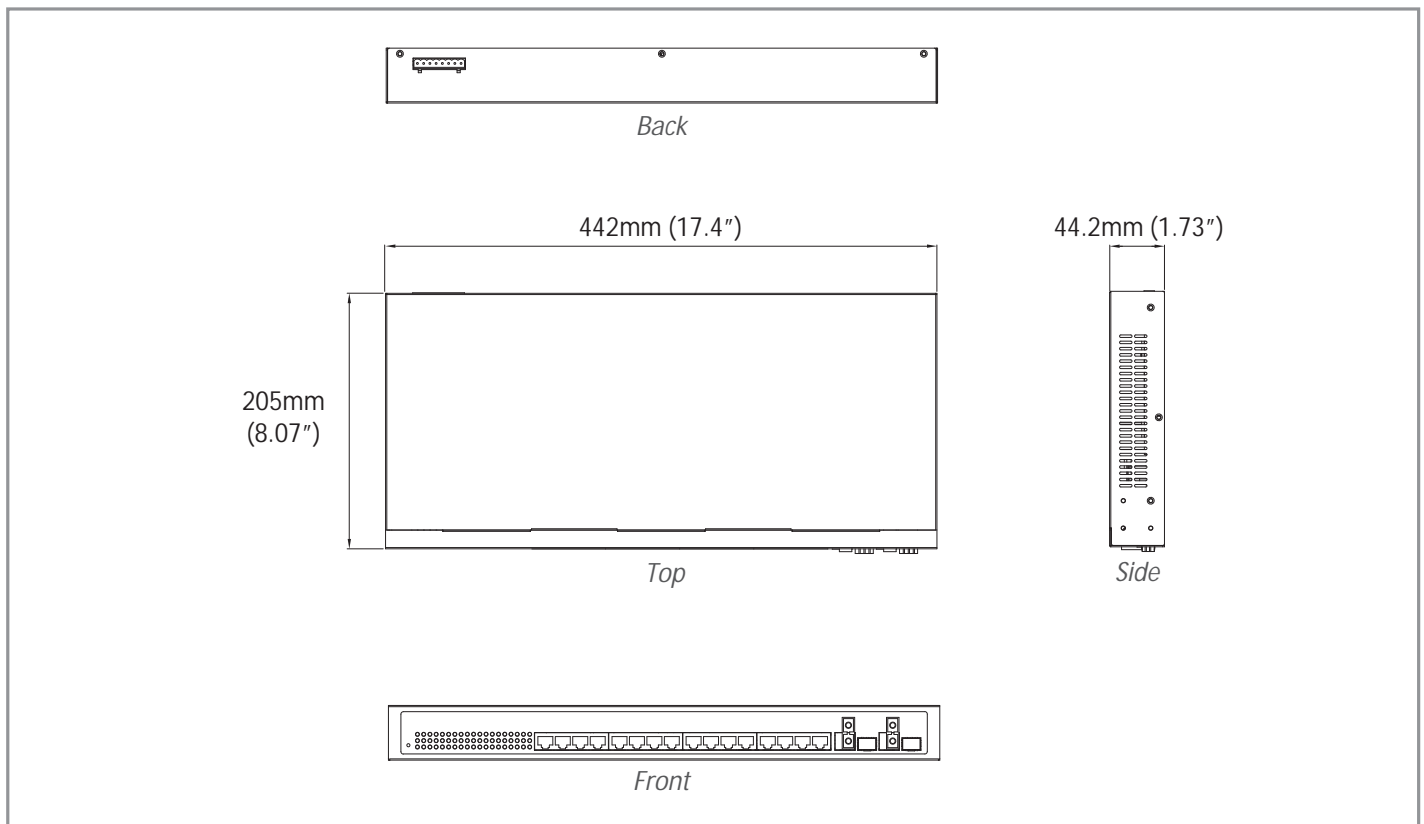

Ordering Information

Model

EX49162A-0XT	Hardened Unmanaged 16-port 10/100BASE-TX + 2-port Gigabit PoE Ethernet Switch
EX49122A-0XT	Hardened Unmanaged 12-port 10/100BASE-TX + 2-port Gigabit PoE Ethernet Switch
EX49082A-0XT	Hardened Unmanaged 8-port 10/100BASE-TX + 2-port Gigabit PoE Ethernet Switch

* Rack mounting kit included

Gigabit Port Options (X)

1	10/100/1000BASE-TX
3	1000BASE-SX(SC) - 550m
4	1000BASE-SX (SC) - 2Km
5	1000BASE-SX (ST) - 550m
A	1000BASE-LX (SC) - 10Km
B	1000BASE-LX (SC) - 20Km
R	1000BASE-BX (SC) WDM-TX:1310nm/RX:1550nm - 20Km
S	1000BASE-BX (SC) WDM-TX:1550nm/RX: 1310nm - 20Km
V	1000BASE SFP Combo with 10/100/1000BASE-T

*More 100FX Fiber options also available upon request.

Optional Accessories

SDR-480-48	480W/10A DIN-Rail 48VDC Industrial Power Supply (Optional)
------------	--

EX42900 Series

Hardened Unmanaged 5/8-port 10/100/1000BASE Gigabit Ethernet Switch



Overview

EtherWAN's EX42900 Series is a compact Hardened Unmanaged Gigabit switching platform, designed for easy deployment in harsh environments.

The EX42900 Series is equipped with five or eight Gigabit Ethernet ports, or a combination of Gigabit copper ports and one Gigabit fiber port for long distance connectivity. Although unmanaged, the EX42900 is feature-rich with Jumbo Frame support, full wire speed Gigabit throughput, QoS support and eco-friendly IEEE802.3az EEE (Energy Efficient Ethernet) compliant, making the EX42900 Series a powerful yet energy efficient network switch.

EtherWAN – "When Connectivity is Crucial."

Spotlight

- **Hardened Grade**
 - Supports -40°C to 75°C (-40°F to 167°F) operating temperature
- **Jumbo Frame Support**
 - Up to 10K bytes (EX42905/EX42914 Series)
 - Up to 9720 bytes (EX42908/EX42917 Series)
- **Fiber Connectivity**
 - Up to one 1000BASE-SX ports with SC and ST options
- **High Reliability**
 - Fanless Design
 - No moving part

Hardware Specifications

Technology

Standards

- IEEE802.3 10BASE-T
- IEEE802.3u 100BASE-TX/100BASE-FX
- IEEE802.3ab 1000BASE-T
- IEEE802.3z 1000BASE-SX/1000BASE-LX
- IEEE802.1x, Full duplex flow control
- IEEE802.1az Energy Efficient Ethernet
- IEEE802.1p Quality of Service (QoS)

Forward and Filtering Rate

- 14,880pps for 10Mbps
- 148,810pps for 100Mbps
- 1,488,100pps for 1000Mbps

Packet Buffer Memory

- EX42905/EX42914: 1M bits
- EX42908/EX42917: 192KB

Processing Type

- Store-and-Forward
- Auto Negotiation
- Half-duplex back-pressure and IEEE802.3x full-duplex flow control
- Auto MDI/MDIX

Jumbo Frame

- EX42905/EX42914: 10K bytes
- EX42908/EX42917: 9720 bytes

Address Table Size

- EX42905/EX42914: 8K MAC addresses
- EX42908/EX42917: 4K MAC addresses

Power

Input Voltage

- 12 to 48VDC

Power Consumption

- 6.5W Max. 0.25A @ 24VDC

Protection

- Reverse polarity protection
- Overload current protection

Mechanical

Casing

- Metal case
- IP30

Dimensions

- EX42905/EX42914:
30mm (W) x 76.3mm (D) x 110mm (H)
(1.18" (W) x 3.05" (D) x 4.4" (H))
- EX42908/EX42917:
30mm (W) x 100mm (D) x 149mm (H)
(1.18" (W) x 4" (D) x 5.96" (H))

Weight

- EX42905/EX42914: 0.34Kg (0.75lb.)
- EX42908/EX42817: 0.39Kg (0.841lb.)

Installation

- DIN-Rail (Top hat type 35mm)

Interface

Ethernet Ports

- EX42905/EX42914:
10/100/1000BASE-T: 5 or 4 ports
1000BASE-X: 0 or 1 ports
- EX42908/EX42917:
10/100/1000BASE-T: 8 or 7 ports
1000BASE-X: 0 or 1 ports

LED Indicators

- EX42905/EX42914:
Per Unit: Power (Green)
Per Port: 10/100M(Green),
1000M (Yellow)
- EX42908/EX42917:
Per Unit : Power 1 (Green),
Power 2 (Green),
Alarm (Red)
Per Port: 10/100M(Green) ,
1000M (Yellow)

Alarm Contact (EX42908/EX42917 only)

- One relay output with current 1A@250VAC
- Supports normal close and normal open

Environment

Operating Temperature

- -40°C to 75°C (-40°F to 167°F);
Tested @ -40°C to 85°C (-40°F to 185°F)

Storage Temperature

- -40°C to 85°C (-40°F to 185°F)

Ambient Relative Humidity

- 5% to 95% (non-condensing)

Regulatory Approvals

ISO

- Manufactured in an ISO9001 facility

Safety

UL60950 (EX42905/EX42914 Series only)

EMI

FCC Part 15B, Class A

VCCI, Class A

EN61000-6-4

EN55022 Class A

EMS

EN61000-6-2

- EN61000-4-2 (ESD Standards)
- EN61000-4-3 (Radiated RFI Standards)
- EN61000-4-4 (Burst Standards)
- EN61000-4-5 (Surge Standards)
- EN61000-4-6 (Induced RFI Standards)
- EN61000-4-8 (Magnetic Field Standards)

Environmental Test Compliances

IEC60068-2-6 Fc (Vibration)

IEC60068-2-27 Ea (Shock)

FED STD 101C Method 5007.1 (Free fall w/ package)

Dimensions

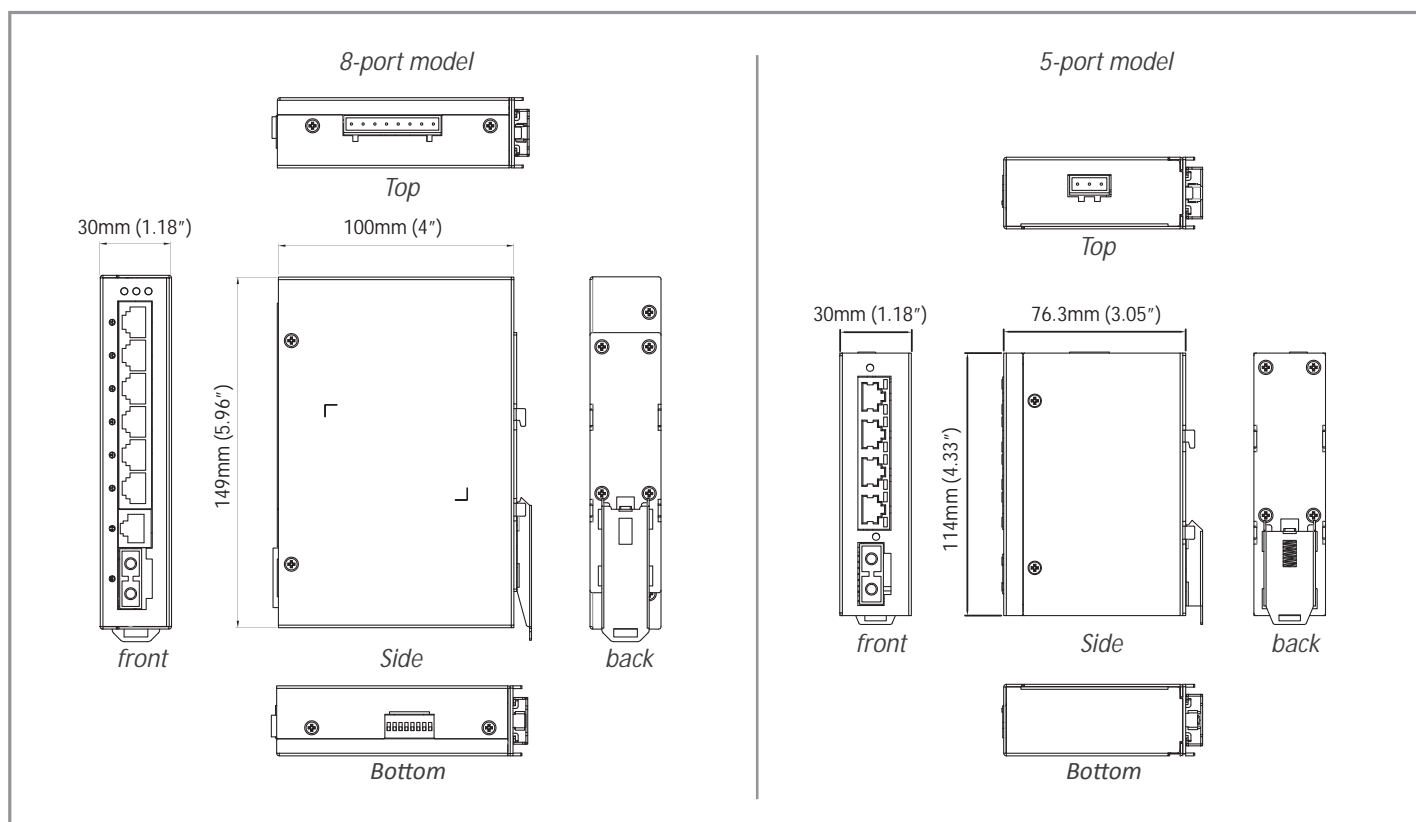

Ordering Information

Model

EX42905	Hardened Unmanaged 5-port 10/100/1000BASE-T Gigabit Ethernet Switch
EX42914-X	Hardened Unmanaged 4-port 10/100/1000BASE-T + 1-port 1000BASE-X Gigabit Ethernet Switch
EX42908	Hardened Unmanaged 8-port 10/100/1000BASE-T Gigabit Ethernet Switch
EX42917-X	Hardened Unmanaged 7-port 10/100/1000BASE-T + 1-port 1000BASE-X Gigabit Ethernet Switch

* DIN-Rail mounting kit included

Optical Port Options (X)

3	1000BASE-SX(SC)-550m
5	1000BASE-SX(ST)-550m
A	1000BASE-LX(SC)-10km
R	1000BASE-BX(SC) WDM-TX:1310nm/RX:1550nm-20Km
S	1000BASE-BX(SC) WDM-TX:1550nm/RX:1310nm-20Km

Optional Accessories

DR-30-24	30W/1.5A DIN-Rail 24VDC Industrial Power Supply (for Terminal Block)
DR-60-24	60W/2.5A DIN-Rail 24VDC Industrial Power Supply (for Terminal Block)
DR-75-24	75W/3.2A DIN-Rail 24VDC Industrial Power Supply (for Terminal Block)
DR-120-24	120W/5A DIN-Rail 24VDC Industrial Power Supply (for Terminal Block)
41-136046-X	36W/3A 12VDC hardened power adapter with open wire in aluminum housing (for Terminal Block) (X) = 1: US, 2: EU, 3: UK, 4: AU, 5: JP, 6: SA

EX42300 Series

Hardened Unmanaged 5/6 port Ethernet Switch
4-port 10/100BASE (4 x PoE) + 1-port 10/100/1000BASE-T
Optional 1-port 1000BASE-X Gigabit



Overview

EtherWAN's EX42300 Series is a compact Hardened Unmanaged PoE switching platform, designed for easy deployment in harsh environments.

The EX42300 Series is equipped 6 Ethernet ports, with a combination of Fast Ethernet copper ports with 4-port PoE (IEEE802.3at), one Gigabit copper port, and one Gigabit fiber port for long distance connectivity. The EX42300 is feature rich with 10K Jumbo Frame support on the Gigabit ports, full wire speed throughput, QoS support and eco-friendly IEEE802.3az EEE (Energy Efficient Ethernet) compliant, making the EX42300 Series a powerful yet energy efficient network switch.

EtherWAN – "When Connectivity is Crucial."

Spotlight

- **Power over Ethernet**
 - Port 1-4 are PoE ports that provide power up to 30W
- **Energy Efficient Ethernet (EEE)**
 - Supports IEEE802.3az standard
- **Fiber Connectivity**
 - Up to one 1000BASE-SX port with SC, ST and SFP options

Hardware Specifications

Technology

Standards

- IEEE802.3 10BASE-T
- IEEE802.3u 100BASE-TX/100BASE-FX
- IEEE802.3ab 1000BASE-T
- IEEE802.3z 1000BASE-SX/1000BASE-LX
- IEEE802.1x Full duplex flow control
- IEEE802.1az Energy Efficient Ethernet
- IEEE802.1p Quality of Service(QoS)
- IEEE802.3af/at Power over Ethernet (PoE)

Forward and Filtering Rate

- 14,880pps for 10Mbps
- 148,810pps for 100Mbps
- 1,488,100pps for 1000Mbps

Packet Buffer Memory

- 1M bits

Processing Type

- Store-and-Forward
- Auto Negotiation
- Half-duplex back-pressure and IEEE802.3x full-duplex flow control
- Auto MDI/MDIX

Jumbo Frame

- 10K bytes

Address Table Size

- 8192 MAC addresses

Power

Input Voltage

- 24/48VDC

Power Consumption

- Device: Max. 7W (without PoE)
- PoE Power budget: 120W

Protection

- Reverse polarity protection
- Overload current protection

Mechanical

Casing

- Metal case
- IP30

Dimensions

- 30mm (W) x 100mm (D) x 149mm (H)
(1.18" (W) x 4" (D) x 5.96" (H))

Weight

- 0.34Kg (0.75lb.)

Installation

- DIN-Rail

Interface

Ethernet Ports

- 10/100BASE-TX: 4 ports
- 10/100/1000BASE-T: 1 port
- 1000BASE-X: 0 or 1 ports

LED Indicators

- Per Unit: Power 1 (Green)
Power 2 (Green)
Alarm (Red)
- Per Port: 10/100M (Green)
1000M (Amber)
- Per PoE Port: PoE status (Amber)

Environment

Operating Temperature

- -40°C to 75°C (-40°F to 167°F)
Tested @ -40°C to 85°C (-40°F to 185°F)

Storage Temperature

- -40°C to 85°C (-40°F to 185°F)

Ambient Relative Humidity

- 5% to 95% (non-condensing)

Regulatory Approvals

ISO

- Manufactured in an ISO9001 facility

Safety

UL60950

EMI

FCC Part 15B, Class A

VCCI Class A

EN61000-6-4

EMS

EN61000-6-2

- EN61000-4-2 (ESD Standards)
- EN61000-4-3 (Radiated RFI Standards)
- EN61000-4-4 (Burst Standards)
- EN61000-4-5 (Surge Standards)
- EN61000-4-6 (Induced RFI Standards)
- EN61000-4-8 (Magnetic Field Standards)

Environmental Test Compliances

IEC60068-2-6 Fc (Vibration)

IEC60068-2-27 Ea (Shock)

FED STD 101C Method 5007.1 (Free fall w/ package)

Dimensions

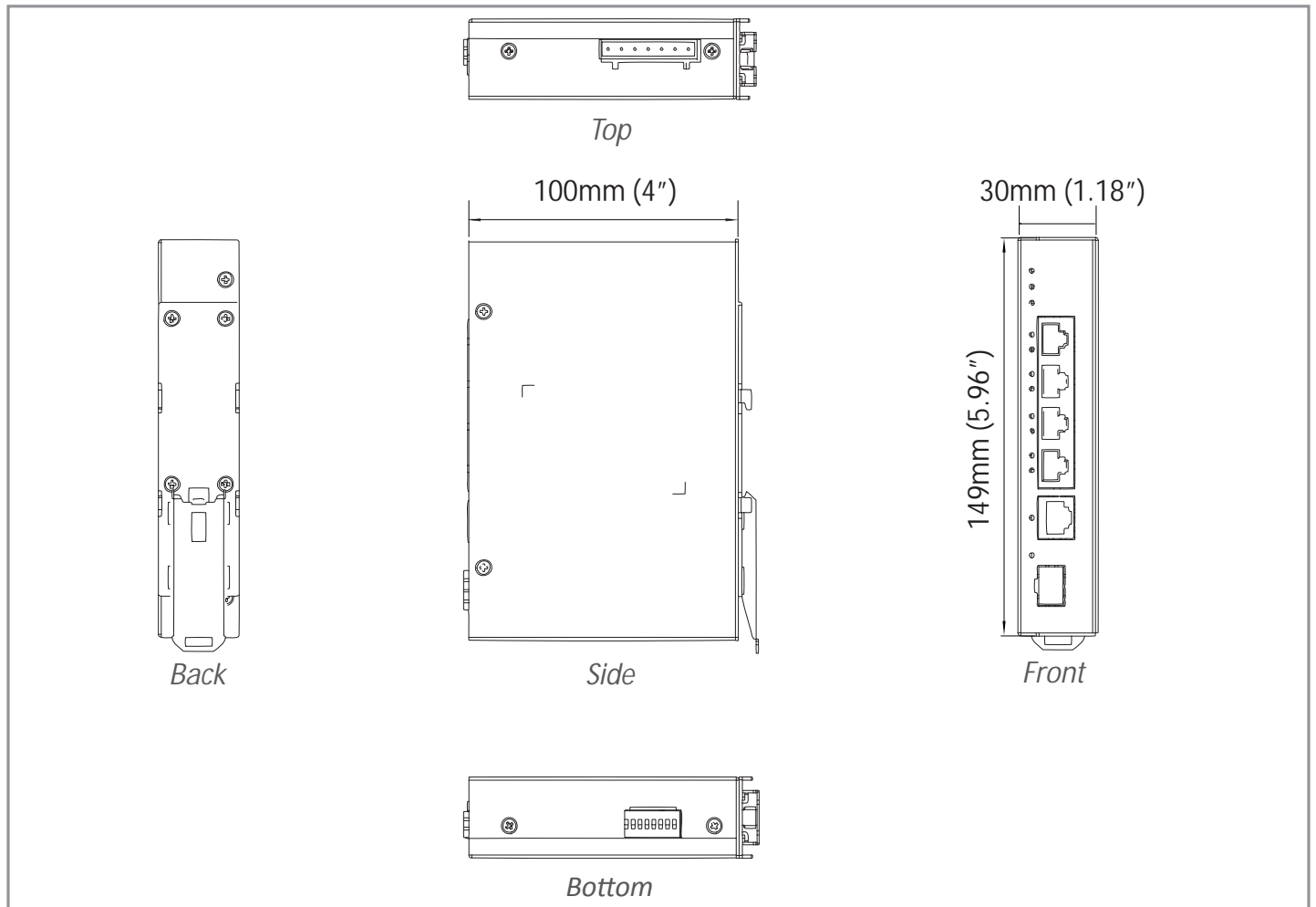

Ordering Information

Model

EX42305	Hardened Unmanaged 4-port 10/100BASE-TX (4 x PoE) + 1-port 10/100/1000BASE-T Gigabit Ethernet Switch
EX42315-X	Hardened Unmanaged 4-port 10/100BASE-TX (4 x PoE) + 1-port 10/100/1000BASE-T + 1-port 1000BASE-X Gigabit Ethernet Switch

* DIN-Rail mounting kit included

Ordering Information - continued

100FX Fiber Options (X)

3	1000BASE-SX(SC)-550m
5	1000BASE-SX(ST)-550m
A	1000BASE-LX(SC)-10km
R	1000BASE-BX(SC) WDM-TX:1310nm/RX:1550nm-20Km
S	1000BASE-BX(SC) WDM-TX:1550nm/RX:1310nm-20Km
V	1000BASE SFP

Optional Accessories

SDR-240-48	240W/5A DIN-Rail 48VDC Industrial Power Supply (for terminal block)
------------	---

EX45900 Series

Hardened Unmanaged 5-port 10/100/1000BASE (4 x PoE)
+ 1-port 1000BASE-X Gigabit Ethernet Switch



Overview

EtherWAN's EX45900 Series provides a hardened 5-port switching platform supporting IEEE802.3at Power over Ethernet, high performance switching with robust features required for mission-critical and harsh environments where sustained connectivity is crucial.

The EX45900 Series is equipped with 4 10/100/1000BASE-TX PoE ports, in combination with one Gigabit Fiber option. The EX45900 is feature rich with 10K Jumbo Frame support, full wire speed Gigabit throughput, QoS support and eco-friendly IEEE802.3az EEE (Energy Efficient Ethernet) compliant, making the EX45900 Series a powerful yet energy efficient network switch.

The IEEE802.3at PoE ports provide up to 30W/port with a total power budget of 120W, making the switch truly versatile for connecting with PoE Powered Devices (PD) with different bandwidth and power consumption requirements such as; outdoor PTZ dome cameras, wireless access points, and way-side communication devices.

EtherWAN – "When Connectivity is Crucial."

Spotlight

- **Power over Ethernet**
 - Port 1-4 are PoE ports that provide power up to 30W
- **Energy Efficient Ethernet (EEE)**
 - Supports IEEE802.3az standard
- **Fiber Connectivity**
 - Up to one 1000BASE-SX ports with SC, ST and SFP options

Hardware Specifications

Technology

Standards

- IEEE802.3 10BASE-T
- IEEE802.3u 100BASE-TX/100BASE-FX
- IEEE802.3ab 1000BASE-T
- IEEE802.3z 1000BASE-SX/1000BASE-LX
- IEEE802.1x Full duplex flow control
- IEEE802.1az Energy Efficient Ethernet
- IEEE802.1p Quality of Service(QoS)
- IEEE802.3af/at Power over Ethernet (PoE)

Forward and Filtering Rate

- 14,880pps for 10Mbps
- 148,810pps for 100Mbps
- 1,488,100pps for 1000Mbps

Packet Buffer Memory

- 1M bits

Processing Type

- Store-and-Forward
- Auto Negotiation
- Half-duplex back-pressure and IEEE802.3x full-duplex flow control
- Auto MDI/MDIX

Jumbo Frame

- 10K bytes

Address Table Size

- 8192 MAC addresses

Power

Input Voltage

- 24/48VDC

Power Consumption

- Device: Max. 7W (without PoE)
- PoE Power budget: 120W

Protection

- Reverse polarity protection
- Overload current protection

Mechanical

Casing

- Metal case
- IP30

Dimensions

- 30mm (W) x 100mm (D) x 149mm (H)
(1.18" (W) x 4" (D) x 5.96" (H))

Weight

- 0.34Kg (0.75lb.)

Installation

- DIN-Rail

Interface

Ethernet Ports

- 10/100/1000BASE-T: 5 ports
- 1000BASE-X: 0 or 1 ports

LED Indicators

- Per Unit: Power 1 (Green)
Power 2 (Green)
Alarm (Red)
- Per Port: 10/100M (Green)
1000M (Amber)
- Per PoE Port: PoE status (Amber)

Alarm Contact

- One relay output with current 1A@250VAC
- Supports normal open

Environment

Operating Temperature

- -40°C to 75°C (-40°F to 167°F);
Tested @ -40°C to 85°C (-40°F to 185°F)

Storage Temperature

- -40°C to 85°C (-40°F to 185°F)

Ambient Relative Humidity

- 5% to 95% (non-condensing)

Regulatory Approvals

ISO

- Manufactured in an ISO9001 facility

Safety

UL60950

EMI

FCC Part 15B, Class A

VCCI Class A

EN61000-6-4

EMS

EN61000-6-2

- EN61000-4-2 (ESD Standards)
- EN61000-4-3 (Radiated RFI Standards)
- EN61000-4-4 (Burst Standards)
- EN61000-4-5 (Surge Standards)
- EN61000-4-6 (Induced RFI Standards)
- EN61000-4-8 (Magnetic Field Standards)

Environmental Test Compliances

IEC60068-2-6 Fc (Vibration)

IEC60068-2-27 Ea (Shock)

FED STD 101C Method 5007.1 (Free fall w/ package)

Dimensions

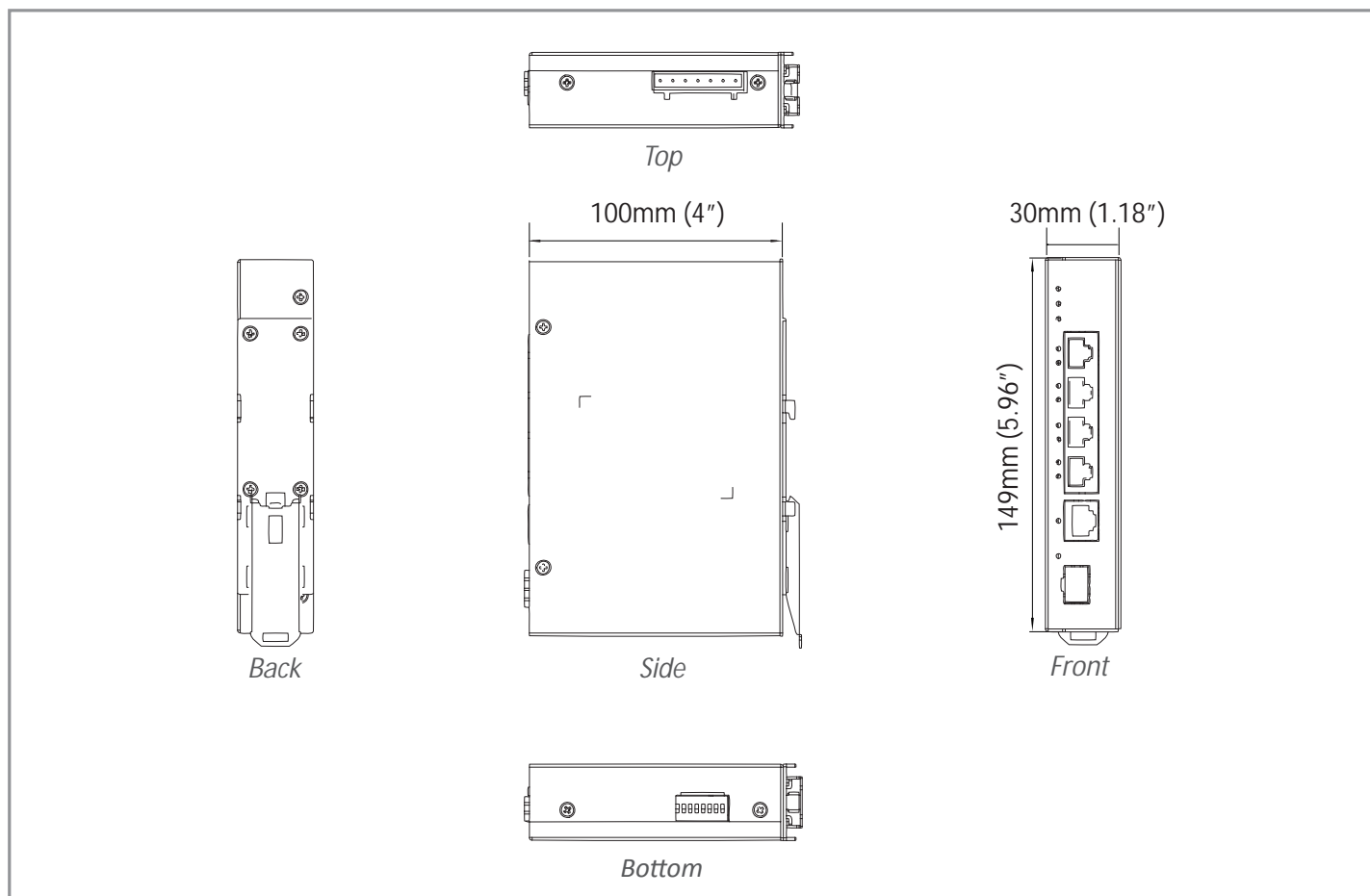

Ordering Information

Model

EX45905	Hardened Unmanaged 5-port 10/100/1000BASE-T (4 x PoE) Gigabit Ethernet Switch
EX45915-X	Hardened Unmanaged 5-port 10/100/1000BASE-T (4 x PoE) + 1-port 1000BASE-X Gigabit Ethernet Switch

* DIN-Rail mounting kit included

Optical Port Options (X)

3	1000BASE-SX(SC)-550m
5	1000BASE-SX(ST)-550m
A	1000BASE-LX(SC)-10km
R	1000BASE-BX(SC) WDM-TX:1310nm/RX:1550nm-20Km
S	1000BASE-BX(SC) WDM-TX:1550nm/RX:1310nm-20Km
V	1000BASE SFP

Optional Accessories

SDR-240-48	240W/5A DIN-Rail 48VDC Industrial Power Supply (for terminal block)
------------	---

EX47000 Series

IEC61850-3/IEEE1613 Hardened Unmanaged 8-port
10/100BASE Ethernet Switch



Overview

EtherWAN's EX47000 Series is a hardened unmanaged Fast Ethernet switching platform, designed for easy deployment in harsh environments.

The EX47000 Series is equipped with 8 Fast Ethernet ports, with a combination of Fast Ethernet copper ports and 100FX ports for long distance connectivity. Although unmanaged, the EX47000 is feature-rich with full wire speed Fast Ethernet throughput, making the EX47000 Series a powerful network switch. With its hardened-grade specifications and IEC61850 & IEEE1613 certifications, the EX47000 Series is capable of operating under high EMI environments at the temperatures ranging from -40°C to 75°C, making it an ideal choice for harsh applications.

EtherWAN – "When Connectivity is Crucial."

Spotlight

- **Hardened Grade**
 - Supports -40°C to 75°C (-40°F to 167°F) operating temperature
- **Versatile mounting Options**
 - DIN-Rail or panel mounting
- **Fiber Connectivity**
 - Up to two 100BASE-FX ports with SC, ST and WDM options

Hardware Specifications

Technology

Standards

- IEEE802.3, 10BASE-T
- IEEE802.3u 100BASE-TX/100BASE-FX
- IEEE802.3x Full duplex and flow control

Forward and Filtering Rate

- 14,880pps for 10Mbps
- 148,810pps for 100Mbps

Packet Buffer Memory

- 448K bits

Processing Type

- Store-and-Forward
- Auto Negotiation
- Half-duplex back-pressure and IEEE802.3x full-duplex flow control
- Auto MDI/MDIX

Address Table Size

- 2048 MAC addresses

Power

Input

- Redundant power inputs:
 - 12 to 48VDC (Terminal Block)
 - 12VDC (DC Jack)

Power Consumption

- 6W Max. 12VDC @ 0.5A
- 24VDC @ 0.25A
- 48VDC @ 0.125A

Protection

- Reverse polarity protection

Mechanical

Casing

- Aluminum Case
- IP30

Dimensions

- 60mm (W) x 125mm (D) x 145mm (H)
(2.36" (W) x 4.92" (D) x 5.7" (H))

Weight

- 1Kg (2.2lbs.)

Installation

- DIN-Rail (Top hat type 35mm) or Panel mounting

Interface

Ethernet Ports

- 10/100BASE-TX: 16, 15 or 14 ports
- 100BASE-FX: 0, 1 or 2 ports

LED Indicators

- Per Unit: Power 1 (Green)
 - Power 2 (Green)
 - Power 3 (Green)
 - Fault (Red)
- Per Port: Link/Act (Green)
 - 100M (Green)

Alarm Contact

- One relay output with current 1A @ 24VDC

Environment

Operating Temperature

- -40°C to 75°C (-40°F to 167°F)
Tested @ -40°C to 85°C (-40°F to 185°F)

Storage Temperature

- -40°C to 85°C (-40°F to 185°F)

Ambient Relative Humidity

- 5% to 95% (non-condensing)

Regulatory Approvals

ISO

- Manufactured in an ISO9001 facility

EMI

FCC Part 15B, Class A

EN61000-6-4

EMS

EN61000-6-2

- EN61000-4-2 (ESD Standards)
- EN61000-4-3 (Radiated FRI Standards)
- EN61000-4-4 (Burst Standards)
- EN61000-4-5 (Surge Standards)
- EN61000-4-6 (Induced RFI Standards)
- EN61000-4-8 (Magnetic Field Standards)

Environmental Test Compliance

IEC60068-2-6 Fc (Vibration)

IEC60068-2-27 Ea (Shock)

FED STD 101C Method 5007.1 (Free fall w/ package)

Industrial Compliance

IEC61850 / IEEE1613

EN50121-4

NEMA TS2

Dimensions

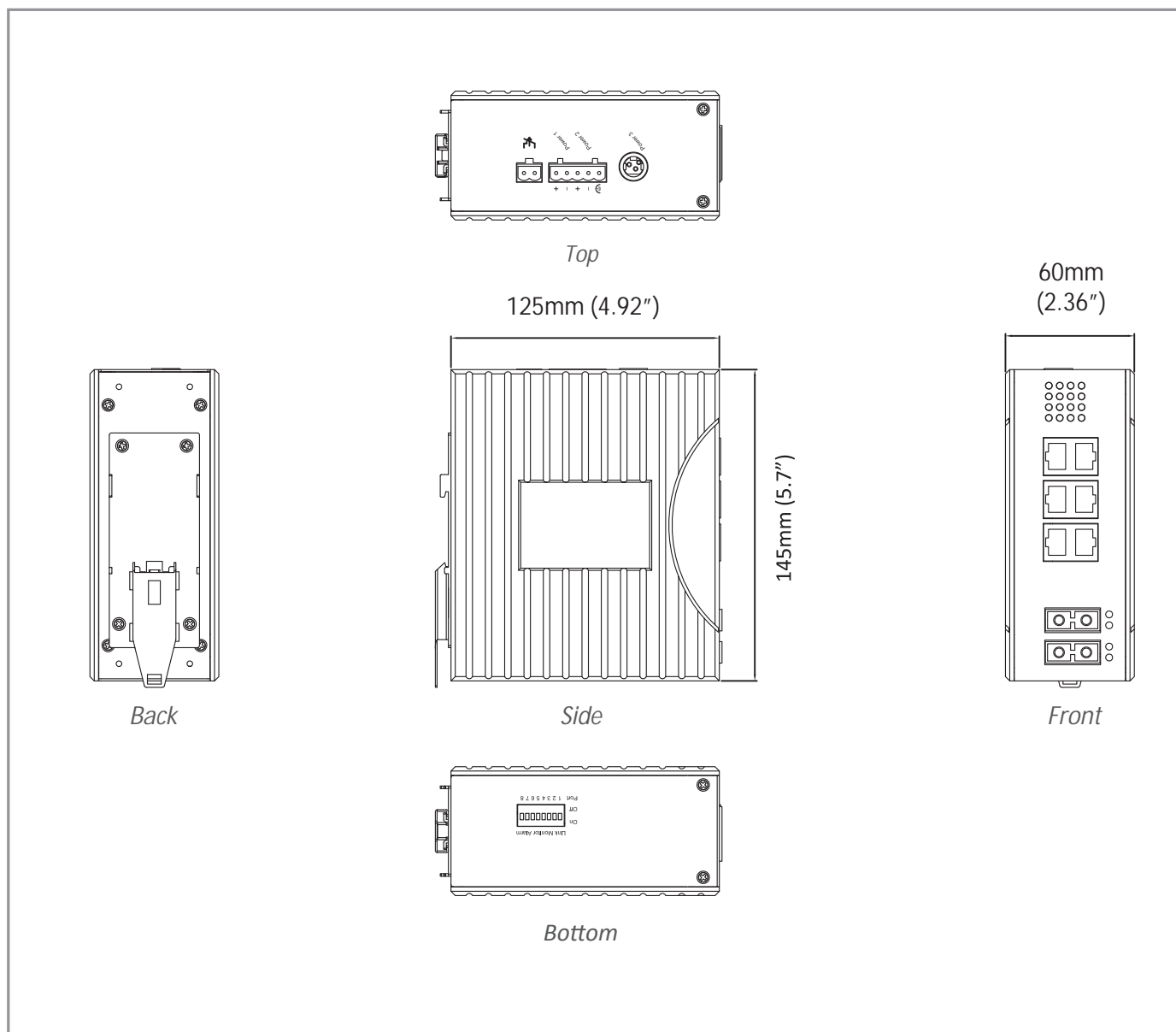

Ordering Information

Model

EX47080-00B	8-port 10/100BASE-TX Hardened Unmanaged Ethernet Switch
EX47062-X0B	6-port 10/100BASE-TX + 2-port 100BASE-FX Hardened Unmanaged Ethernet Switch
EX47061-X0B	6-port 10/100BASE-TX + 1-port 100BASE-FX Hardened Unmanaged Ethernet Switch
EX47042-X0B	4-port 10/100BASE-TX + 2-port 100BASE-FX Hardened Unmanaged Ethernet Switch
EX47041-X0B	4-port 10/100BASE-TX + 1-port 100BASE-FX Hardened Unmanaged Ethernet Switch
EX47026-X0B	2-port 10/100BASE-TX + 6-port 100BASE-FX Hardened Unmanaged Ethernet Switch

* DIN-Rail mounting kit included

Ordering Information - continued

100FX Fiber Options (X)

1	Multi Mode (SC) - 2Km
2	Multi Mode (ST) - 2Km
6	Multi Mode (SC) WDM-TX:1310nm/RX:1550nm - 2Km
7	Multi Mode (SC) WDM-TX:1550nm/RX:1310nm - 2Km
8	Multi Mode (SC) WDM-TX:1310nm/RX:1550nm - 5Km
9	Multi Mode (SC) WDM-TX:1550nm/RX:1310nm - 5Km
A	Single Mode (SC) - 20Km
B	Single Mode (SC) - 40Km
H	Single Mode (ST) - 20Km
P	Single Mode (SC) WDM-TX:1310nm/RX:1550nm - 20Km
Q	Single Mode (SC) WDM-TX:1550nm/RX:1310nm - 20Km
R	Single Mode (SC) WDM-TX:1310nm/RX:1550nm - 40Km
S	Single Mode (SC) WDM-TX:1550nm/RX:1310nm - 40Km

**More 100FX Fiber options also available upon request.*

Optional Accessories

KP-AA96-480	Panel mounting kit
DR-30-24	30W/1.5A DIN-Rail 24VDC Industrial Power Supply (for Terminal Block)
DR-60-24	60W/2.5A DIN-Rail 24VDC Industrial Power Supply (for Terminal Block)
DR-75-24	75W/3.2A DIN-Rail 24VDC Industrial Power Supply (for Terminal Block)
DR-120-24	120W/5A DIN-Rail 24VDC Industrial Power Supply (for Terminal Block)
41-136046-X	36W/3A 12VDC hardened power adapter with open wire in aluminum housing (for Terminal Block) (X) = 1: US, 2: EU, 3: UK, 4: AU, 5: JP, 6: SA
41-136044-X	36W/3A 12VDC hardened power adapter with latched DC Jack in aluminum housing (for DC Jack) (X) = 1: US, 2: EU, 3: UK, 4: AU, 5: JP, 6: SA

EX45000 Series

Hardened Unmanaged 8-port 10/100BASE PoE (4 x PoE)
Ethernet Switch



Overview

EtherWAN's EX45000 Series provides a hardened 8-port switching platform supporting IEEE802.3af Power over Ethernet, high performance switching with robust features required for mission-critical and harsh environments where sustained connectivity is crucial.

The EX45000 Series is equipped with 4 10/100BASE-TX PoE ports, in combination with two 100FX Fiber options.

The IEEE802.3af PoE ports provide up to 15.4W/port with a total power budget of 61.6W, making the switch truly versatile for connecting with PoE Powered Devices (PD) with different bandwidth and power consumption requirements.

The EX45000 Series is designed to operate at -40°C to 75°C in harsh environments, where high ESD, shock, and vibration may be present.

EtherWAN — "When Connectivity is Crucial."

Spotlight

- **Hardened Grade**
 - Supports -40°C to 75°C (-40°F to 167°F) operating temperature
- **PoE Connectivity**
 - Port 1 to 4 supports IEEE802.3af Power over Ethernet
- **Fiber Connectivity**
 - Up to two 100BASE-FX ports with SC and ST options

Hardware Specifications

Technology

Standards

- IEEE802.3 10BASE-T
- IEEE802.3u 100BASE-TX/100BASE-FX
- IEEE802.3x Full duplex and flow control
- IEEE802.3af Power over Ethernet

Forward and Filtering Rate

- 14,880pps for 10Mbps
- 148,810pps for 100Mbps

Packet Buffer Memory

- 1M bits

Processing Type

- Store-and-Forward
- Auto Negotiation
- Half-duplex back-pressure and IEEE802.3x full-duplex flow control
- Auto MDI/MDIX

Address Table Size

- 1024 MAC addresses

Power

Input

- Redundant power inputs:
Terminal Block: 47 - 55VDC
DC Jack: 47 - 55VDC

Power Consumption

- Device: Max. 10W (without PoE)
- PoE power budget (depends on power input):
61.6W Max.

PoE Power Output

- Port 1 to 4
- IEEE802.3af: up to 15.4W/port, 47 - 55VDC, 350mA Max.

Protection

- Reverse polarity protection
- Overload current protection

Mechanical

Casing

- Aluminum case
- IP30

Dimensions

- 68mm (W) x 110mm (D) x 135mm (H)
(2.68" (W) x 4.33" (D) x 5.31" (H))

Weight

- 1Kg (2.2lbs.)

Installation

- DIN-Rail (Top hat type 35mm), Panel, or Rack mounting

Interface

Ethernet Ports

- 10/100BASE-TX: 8, 7 or 6 ports
- 100BASE-FX: 0, 1 or 2 ports

LED Indicators

- Per Unit: Power 1 (Green)
Power 2 (Green)
Power 3 (Green)
- Per Port: Link/Activity (Green)

Alarm Contact

- One relay output with current 1A @ 24VDC

Environment

Operating Temperature

- -40°C to 75°C (-40°F to 167°F)
Tested @ -40°C to 85°C (-40°F to 185°F)

Storage Temperature

- -40°C to 85°C (-40°F to 185°F)

Ambient Relative Humidity

- 5% to 95% (non-condensing)

Regulatory Approvals

ISO

- Manufactured in an ISO9001 facility

EMI

FCC Part 15B, Class A

VCCI Class A

EN61000-6-4

EN55022 Class A

EMS

EN61000-6-2

- EN61000-4-2 (ESD Standards)
- EN61000-4-3 (Radiated RFI Standards)
- EN61000-4-4 (Burst Standards)
- EN61000-4-5 (Surge Standards)
- EN61000-4-6 (Induced RFI Standards)
- EN61000-4-8 (Magnetic Field Standards)

Environmental Test Compliances

IEC60068-2-6 Fc (Vibration)

IEC60068-2-27 Ea (Shock)

FED STD 101C Method 5007.1 (Free fall w/ package)

Industrial Compliances

NEMA TS2

Dimensions

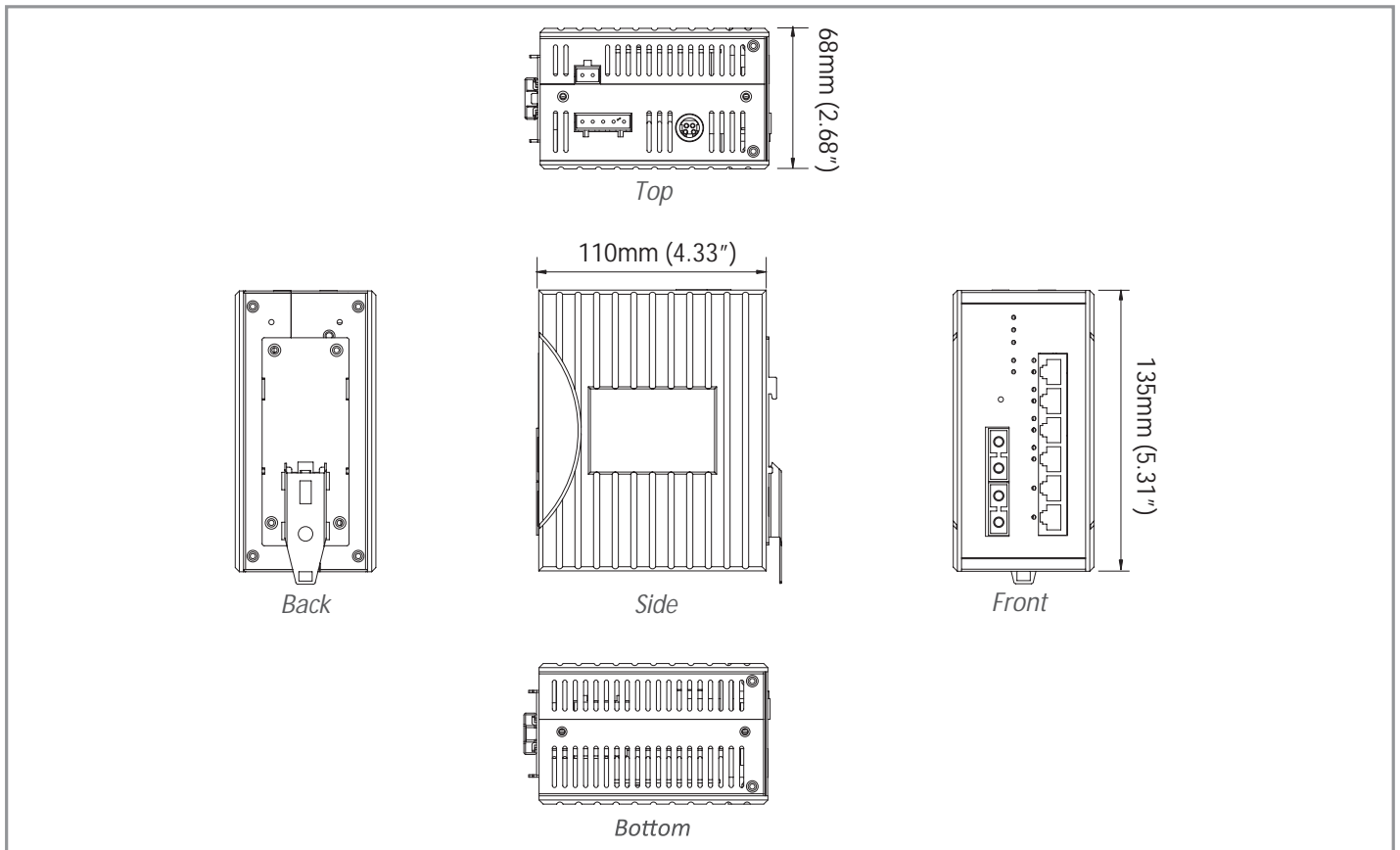

Ordering Information

Model

EX45080-00B	8-port 10/100BASE-TX Hardened Unmanaged PoE Ethernet Switch
EX45071-X0B	7-port 10/100BASE-TX + 1-port 100BASE-FX Hardened Unmanaged PoE Ethernet Switch
EX45062-X0B	6-port 10/100BASE-TX + 2-port 100BASE-FX Hardened Unmanaged PoE Ethernet Switch

* DIN-Rail mounting kit included

100FX Fiber Options (X)

1	Multi Mode (SC) - 2Km
2	Multi Mode (ST) - 2Km
6	Multi Mode (SC) WDM-TX:1310nm/RX:1550nm - 2Km
7	Multi Mode (SC) WDM-TX:1550nm/RX:1310nm - 2Km
8	Multi Mode (SC) WDM-TX:1310nm/RX:1550nm - 5Km
9	Multi Mode (SC) WDM-TX:1550nm/RX:1310nm - 5Km
A	Single Mode (SC) - 20Km
B	Single Mode (SC) - 40Km
H	Single Mode (ST) - 20Km
P	Single Mode (SC) WDM-TX:1310nm/RX:1550nm - 20Km
Q	Single Mode (SC) WDM-TX:1550nm/RX:1310nm - 20Km
R	Single Mode (SC) WDM-TX:1310nm/RX:1550nm - 40Km
S	Single Mode (SC) WDM-TX:1550nm/RX:1310nm - 40Km

*More 100FX Fiber options also available upon request.

Ordering Information - continued

Optional Accessories

KP-AA96-480	Panel mounting Kit
KR-BK43-400	Rack mounting Kit
DR-120-48	120W/2.5A DIN-Rail 48VDC Industrial Power Supply (for terminal block)

EX94000 Series

Hardened Unmanaged 8-port 10/100BASE Ethernet Switch



Overview

EtherWAN's EX94000 Series is a hardened unmanaged Fast Ethernet switching platform, designed for easy deployment in harsh environments. The EX94000 Series supports 12 to 48VDC redundant power input, and also provides relay alarm while power failure or port link down occur. The EX94000 provides 4kV surge protection, and is designed for hazardous locations (Class 1 Div.2 / ATEX Zone 2).

The EX94000 is equipped with eight Fast Ethernet ports, or a combination of Fast Ethernet copper ports and two 100FX ports for long distance connectivity. This versatile switch features 10/100Mbps transfer speeds, full/half-duplex auto-negotiation and auto MDI/MDIX operation allowing you to connect your network devices without hassles.

The EX94000 is feature-rich with full wire speed Fast Ethernet throughput, QoS (Quality of Service), IEEE802.3az EEE (Energy Efficient Ethernet) and Broadcast storm protection. The EX94000 Series is built with relay alarm to notify users when power fails or link down occurs. It also supports Broadcast storm protection by enabling the DIP switch. The 94000 Series is housed with DIN rail mountable metal compact case which is an ideal solution for applications in harsh environments.

EtherWAN – "When Connectivity is Crucial."

Spotlight

- **Hardened Grade**
 - Supports -40°C to 75°C (-40°F to 167°F) operating temperature
- **Broadcast Storm Protection**
 - Enable/disable broadcast storm protection by DIP switch that provide another level of flexibility on industrial applications
- **Fiber Connectivity**
 - Up to two 100BASE-FX ports with SC, ST, WDM and SFP options
- **High Surge Protection and Hazardous Location Certification**
 - Provides 4kV surge protection
 - Designed for hazardous locations (Class 1 Div.2 / ATEX Zone 2)
- **High Reliability**
 - Fanless design
 - No moving parts

Hardware Specifications

Technology

Standards

- IEEE802.3u 100BASE-TX/FX
- IEEE802.3x full-duplex flow control
- IEEE802.3az Energy Efficient Ethernet
- IEEE802.1p Quality of Service (QoS)

Forward and Filtering Rate

- 14,880pps for 10Mbps
- 148,810pps for 100Mbps

Packet Buffer Memory

- 448K bits

Processing Type

- Store-and-Forward
- Auto Negotiation
- Half-duplex back-pressure and IEEE802.3x full-duplex flow control
- Auto MDI/MDIX

Address Table Size

- 1K MAC addresses

Power

Input Voltage

- 12 to 48VDC (Terminal Block)

Power Consumption

- 2.47W@24VDC

Protection

- Reverse polarity protection
- Overload current protection

Mechanical

Casing

- Aluminum Case
- IP30

Dimensions

- 50mm (W) x 110mm (D) x 135mm (H)
(1.97" (W) x 4.33" (D) x 5.31" (H))

Weight

- 0.62Kg (1.37lbs)

Installation

- DIN-Rail (Top hat type 35mm) or Panel mounting

Interface

Ethernet Ports

- 10/100BASE-TX: 8, 6 or 4 ports
- 100BASE-FX: 0, 2 or 1 ports

LED Indicators

- Per Unit: Power 1 (Green),
Power 2 (Green),
Fault (Red)
- Per Port: Link/Activity (Green)

Alarm Contact

- One relay output with current 1A @ 250VAC
- Supports normal close and normal open

Environment

Operating Temperature

- -40°C to 75°C (-40°F to 167°F)
Tested @ -40°C to 85°C (-40°F to 185°F)

Storage Temperature

- -40°C to 85°C (-40°F to 185°F)

Ambient Relative Humidity

- 5% to 95% (non-condensing)

Regulatory Approvals

ISO

- Manufactured in an ISO9001 facility

Safety

UL60950-1 (Pending)

UL ISA12.12.01 Class I Div. 2 / ATEX Zone 2 for hazardous locations (Pending)

EMI

FCC Part 15B, Class A

VCCI Class A

EN61000-6-4

EN55022 Class A

EMS

EN61000-6-2

- EN61000-4-2 (ESD Standards)
- EN61000-4-3 (Radiated FRI Standards)
- EN61000-4-4 (Burst Standards)
- EN61000-4-5 (Surge Standards)
Signal ports: ±4kV line-to-earth
DC power ports: ±4kV line-to-earth
±2kV line-to-line
- EN61000-4-6 (Induced RFI Standards)
- EN61000-4-8 (Magnetic Field Standards)

Environmental Test Compliance

IEC60068-2-6 Fc (Vibration)

IEC60068-2-27 Ea (Shock)

FED STD 101C Method 5007.1 (Free fall w/ package)

- Tested with Cross Weight and Drop High standard table

Dimensions

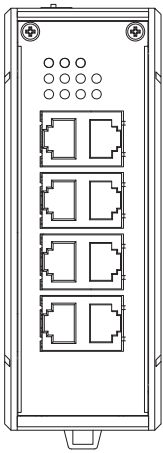
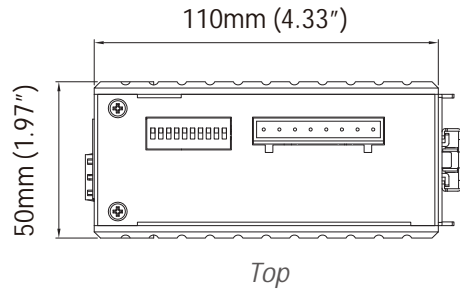

Front
EX94008

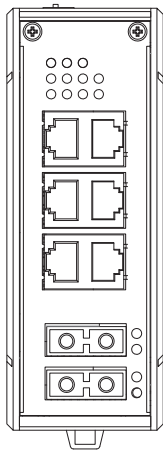

Front
EX94026

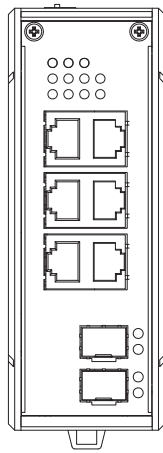

Front
EX94026

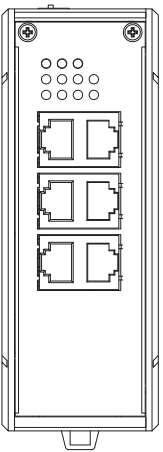
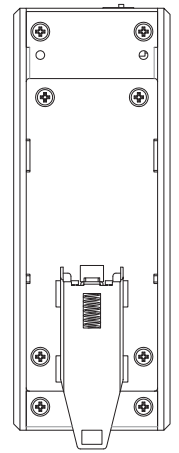
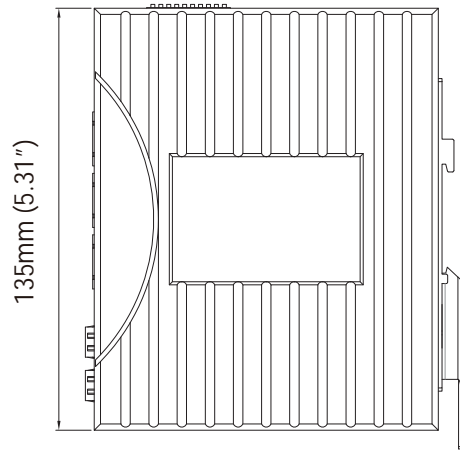

Front
EX94006

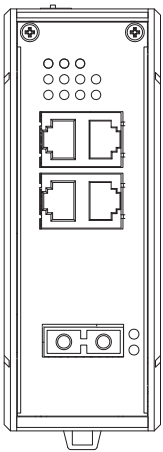

Front
EX94014

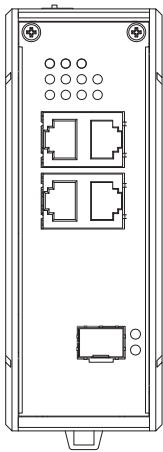

Front
EX94014



Ordering Information

Model

EX94008-00-1-AA	Hardened Unmanaged 8-port 10/100BASE-TX Ethernet Switch
EX94006-00-1-AA	Hardened Unmanaged 6-port 10/100BASE-TX Ethernet Switch
EX94026-XY-1-AA	Hardened Unmanaged 6-port 10/100BASE-TX + 2-port 100BASE-FX Ethernet Switch
EX94014-XY-1-AA	Hardened Unmanaged 4-port 10/100BASE-TX + 1-port 100BASE-FX Ethernet Switch

* DIN-Rail mounting kit included

100FX Fiber Options (XY)

1A	Multi Mode (SC) -2Km
1B	Multi Mode (ST) -2Km
2A	Single Mode (SC) -20Km
2D	Single Mode (ST) -20Km
2E	Single Mode (SC) WDM-TX:1310nm/RX:1550nm -20Km
2G	Single Mode (SC) WDM-TX:1550nm/RX:1310nm -20Km
V	100BASE SFP

*More 100FX Fiber options also available upon request.

Optional Accessories

KP-AA96-480	Panel Mounting Kit
KR-BKEL900	Rack Mounting Kit
DR-30-24	30W/1.5A DIN-Rail 24VDC Industrial Power Supply (for Terminal Block)
DR-60-24	60W/2.5A DIN-Rail 24VDC Industrial Power Supply (for Terminal Block)
DR-75-24	75W/3.2A DIN-Rail 24VDC Industrial Power Supply (for Terminal Block)

EX95000 Series

Hardened Unmanaged 16-port 10/100BASE Ethernet Switch



Overview

EtherWAN's EX95000 Series is a hardened unmanaged Fast Ethernet switching platform, designed for easy deployment in harsh environments.

The EX95000 Series is equipped with sixteen Fast Ethernet ports, or a combination of Fast Ethernet copper ports and two 100FX ports for long distance connectivity. Although unmanaged, the EX95000 is feature-rich with full wire speed Fast Ethernet throughput, making the EX95000 Series a powerful network switch.

EtherWAN – "When Connectivity is Crucial."

Spotlight

- **Hardened Grade**
 - Supports -40°C to 75°C (-40°F to 167°F) operating temperature
- **Versatile mounting Options**
 - DIN-Rail, panel or rack mounting
- **Fiber Connectivity**
 - Up to two 100BASE-FX ports with SC, ST and WDM options

Hardware Specifications

Technology

Standards

- IEEE802.3 10BASE-T
- IEEE802.3u 100BASE-TX/100BASE-FX
- IEEE802.3x Full duplex and flow control

Forward and Filtering Rate

- 14,880pps for 10Mbps
- 148,810pps for 100Mbps

Packet Buffer Memory

- 1.625M bits

Processing Type

- Store-and-Forward
- Auto Negotiation
- Half-duplex back-pressure and IEEE802.3x full-duplex flow control
- Auto MDI/MDIX

Address Table Size

- 4096 MAC addresses

Latency

- Less than 10µs

Power

Input Voltage

- 12 to 48VDC (Terminal Block)
- 12VDC (DC Jack)

Power Consumption

- 7.4W Max. 0.6A @ 12VDC
- 0.3A @ 24VDC
- 0.15A @ 48VDC

Protection

- Overload current protection

Mechanical

Casing

- Aluminum Case
- IP30

Dimensions

- 75.5mm (W) x 110mm (D) x 135mm (H)
(2.98" (W) x 4.33" (D) x 5.31" (H))

Weight

- 0.87Kg (1.92lbs.)

Installation

- DIN-Rail (Top hat type 35mm), Panel, Rack mounting

Interface

Ethernet Ports

- 10/100BASE-TX: 16, 15 or 14 ports
- 100BASE-FX: 0, 1 or 2 ports

LED Indicators

- Per Unit: Power 1 (Green),
Power 2 (Green),
Power 3 (Green)
- Per Port: Link/Activity (Green)

Alarm Contact

- One relay output with current 1A @ 24VDC

Environment

Operating Temperature

- -40°C to 75°C (-40°F to 167°F)

Storage Temperature

- -40°C to 85°C (-40°F to 185°F)

Ambient Relative Humidity

- 5% to 95% (non-condensing)

Regulatory Approvals

ISO

- Manufactured in an ISO9001 facility

Safety

UL508

EMI

FCC Part 15B, Class A

VCCI Class A

EN61000-6-4

EN55022

EN61000-3-2

EN61000-3-3

EMS

EN61000-6-2

- EN61000-4-2 (ESD Standards)
- EN61000-4-3 (Radiated RFI Standards)
- EN61000-4-4 (Burst Standards)
- EN61000-4-5 (Surge Standards)
- EN61000-4-6 (Induced RFI Standards)
- EN61000-4-8 (Magnetic Field Standards)

Environmental Test Compliance

IEC60068-2-6 Fc (Vibration)

IEC60068-2-27 Ea (Shock)

FED STD 101C Method 5007.1 (Free fall w/ package)

Industrial Compliance

NEMA TS2

Dimensions

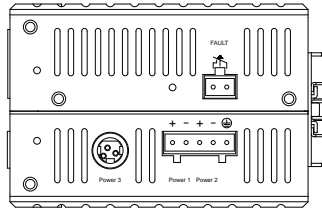

Top

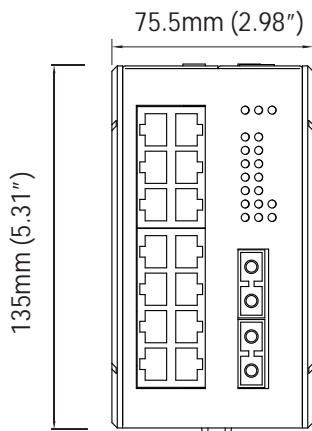

Front

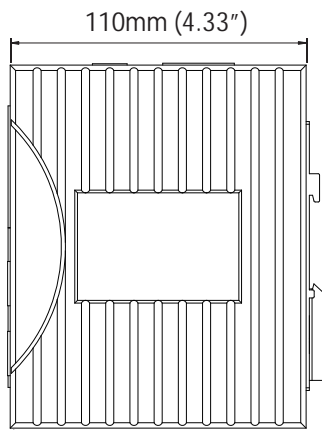

Side

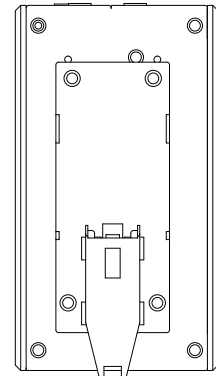

Back

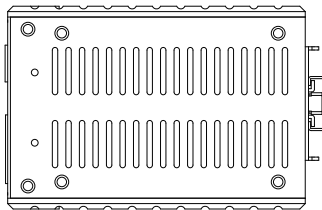

Bottom

Ordering Information

Model

EX95160-00B	16-port 10/100BASE-TX Hardened Unmanaged Ethernet Switch
EX95151-X0B	15-port 10/100BASE-TX + 1-port 100BASE-FX Hardened Unmanaged Ethernet Switch
EX95142-X0B	14-port 10/100BASE-TX + 2-port 100BASE-FX Hardened Unmanaged Ethernet Switch

* DIN-Rail mounting kit included

100FX Fiber Options (X)

1	Multi Mode (SC) - 2Km
2	Multi Mode (ST) - 2Km
6	Multi Mode (SC) WDM-TX:1310nm/RX:1550nm - 2Km
7	Multi Mode (SC) WDM-TX:1550nm/RX:1310nm - 2Km
8	Multi Mode (SC) WDM-TX:1310nm/RX:1550nm - 5Km
9	Multi Mode (SC) WDM-TX:1550nm/RX:1310nm - 5Km
A	Single Mode (SC) - 20Km
B	Single Mode (SC) - 40Km
H	Single Mode (ST) - 20Km
P	Single Mode (SC) WDM-TX:1310nm/RX:1550nm - 20Km
Q	Single Mode (SC) WDM-TX:1550nm/RX:1310nm - 20Km
R	Single Mode (SC) WDM-TX:1310nm/RX:1550nm - 40Km
S	Single Mode (SC) WDM-TX:1550nm/RX:1310nm - 40Km

Optional Accessories

KP-AA96-480	Panel mounting kit
KR-BK-43-400	Rack mounting Kit
DR-30-24	30W/1.5A DIN-Rail 24VDC Industrial Power Supply (for Terminal Block)
DR-60-24	60W/2.5A DIN-Rail 24VDC Industrial Power Supply (for Terminal Block)
DR-75-24	75W/3.2A DIN-Rail 24VDC Industrial Power Supply (for Terminal Block)
DR-120-24	120W/5A DIN-Rail 24VDC Industrial Power Supply (for Terminal Block)
41-136046-X	36W/3A 12VDC hardened power adapter with open wire in aluminum housing (for Terminal Block) (X) = 1: US, 2: EU, 3: UK, 4: AU, 5: JP, 6: SA
41-136044-X	36W/3A 12VDC hardened power adapter with latched DC Jack in aluminum housing (for DC Jack) (X) = 1: US, 2: EU, 3: UK, 4: AU, 5: JP, 6: SA

EX48000A Series

Hardened Unmanaged 5-port 10/100BASE PoE (4 x PoE)
Ethernet Switch



Overview

EtherWAN's EX48000A Series provides a hardened 5-port switching platform supporting IEEE802.3af Power over Ethernet, high performance switching with robust features required for mission-critical and harsh environments where sustained connectivity is crucial.

The EX48000A Series is equipped with four 10/100BASE-TX PoE ports, in combination with one 100FX Fiber option. The IEEE802.3af PoE ports provide up to 15.4W/port with a total power budget of 61.6W, making the switch truly versatile for connecting with PoE Powered Devices (PD) with different bandwidth and power consumption requirements.

The EX48000A Series is designed to operate at -40°C to 75°C in harsh environments, where high ESD, shock, and vibration may be present.

EtherWAN — "When Connectivity is Crucial."

Spotlight

- **Hardened Grade**
 - Supports -40°C to 75°C (-40°F to 167°F) operating temperature
- **PoE Connectivity**
 - Port 1 to 4 supports IEEE802.3af Power over Ethernet
- **Fiber Connectivity**
 - Up to one 100BASE-FX ports with SC and ST options

Hardware Specifications

Technology

Standards

- IEEE802.3 10BASE-T
- IEEE802.3u 100BASE-TX/100BASE-FX
- IEEE802.3af Power over Ethernet
- IEEE802.3x Full duplex and flow control

Forward and Filtering Rate

- 14,880pps for 10Mbps
- 148,810pps for 100Mbps

Packet Buffer Memory

- 512K bits

Processing Type

- Store-and-Forward
- Auto Negotiation
- Half-duplex back-pressure and IEEE802.3x full-duplex flow control
- Auto MDI/MDIX

Address Table Size

- 1024 MAC addresses

Power

Input

- Redundant power inputs:
Terminal Block: 47 - 57VDC
DC Jack: 47 - 57VDC

Power Consumption

- Device: Max. 10W (without PoE)
- PoE power budget (depends on power input): 61.6W Max.

PoE Power Output

- Port 1 to 4
- IEEE802.3af: up to 15.4W/port, 47 - 55VDC, 350mA Max.

Protection

- Reverse polarity protection
- Overload current protection

Mechanical

Casing

- Metal case
- IP30

Dimensions

- 200mm (W) x 134.3mm (D) x 35mm (H)
(7.87" (W) x 5.29" (D) x 1.38" (H))

Weight

- 0.8Kg (1.76lbs.)

Installation

- Desktop, Wall, or DIN-Rail mounting

Interface

Ethernet Ports

- 10/100BASE-TX: 5 or 4 ports
- 100BASE-FX: 0 or 1 ports

LED Indicators

- Per Unit: Power 1 (Green),
Power 2 (Green),
Power 3 (Green),
Fault (Red)
- Per Port: Link/Activity (Green)

Alarm Contact

- One relay output with current 1A @ 250VAC

Environment

Operating Temperature

- -40°C to 75°C (-40°F to 167°F)
Tested @ -40°C to 85°C (-40°F to 185°F)

Storage Temperature

- -40°C to 85°C (-40°F to 185°F)

Ambient Relative Humidity

- 5% to 95% (non-condensing)

Regulatory Approvals

ISO

- Manufactured in an ISO9001 facility

EMI

FCC Part 15B, Class A

EN61000-6-4

EN55022 Class A

EMS

EN61000-6-2

- EN61000-4-2 (ESD Standards)
- EN61000-4-3 (Radiated FRI Standards)
- EN61000-4-4 (Burst Standards)
- EN61000-4-5 (Surge Standards)
- EN61000-4-6 (Induced RFI Standards)
- EN61000-4-8 (Magnetic Field Standards)

Environmental Test Compliances

IEC60068-2-6 Fc (Vibration)

IEC60068-2-27 Ea (Shock)

FED STD 101C Method 5007.1 (Free fall w/ package)

Dimensions

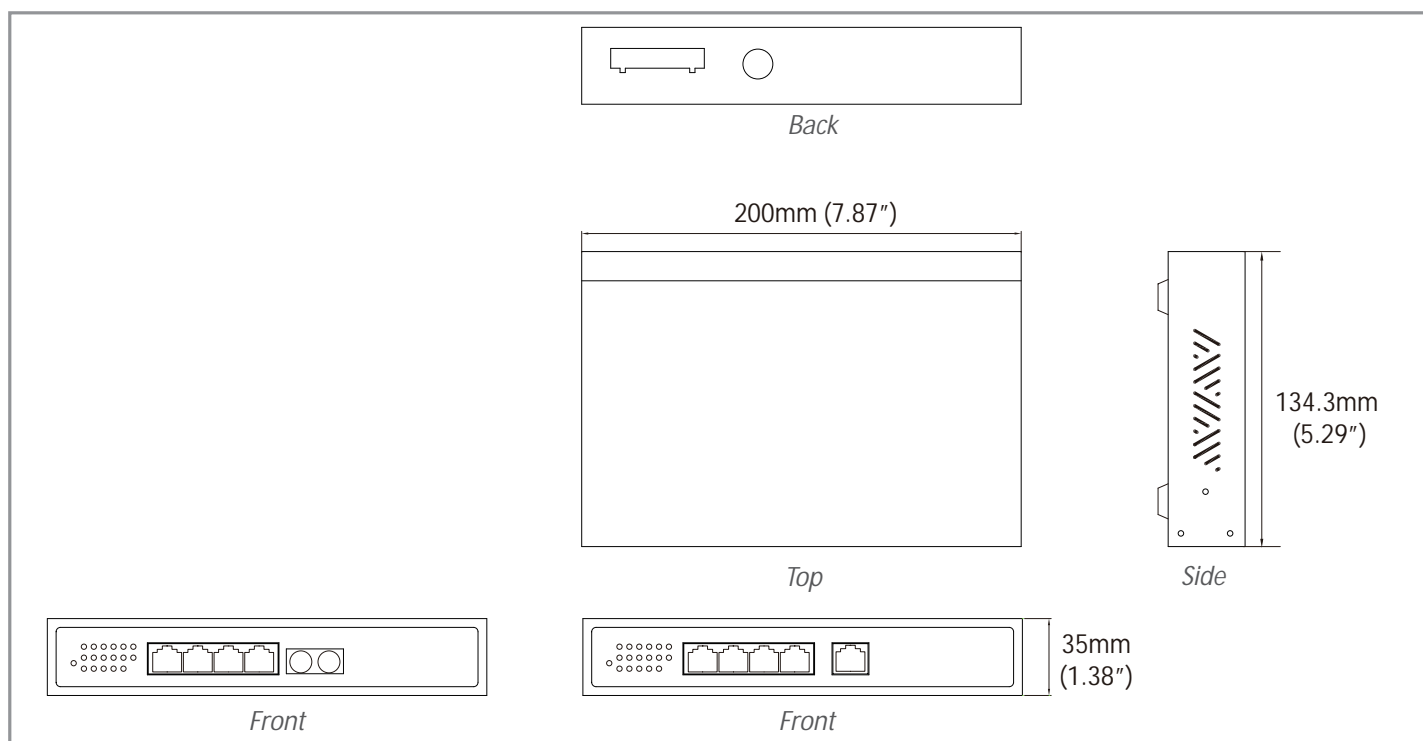

Ordering Information

Model

EX48050A-00B	Hardened Unmanaged 5-port 10/100BASE-TX PoE Ethernet Switch
EX48041A-X0B	Hardened Unmanaged 4-port 10/100BASE-TX + 1-port 100BASE-FX PoE Ethernet Switch

* DIN-Rail mounting kit included

100FX Fiber Options (X)

1	Multi Mode (SC) - 2Km
2	Multi Mode (ST) - 2Km
6	Multi Mode (SC) WDM-TX:1310nm/RX:1550nm - 2Km
7	Multi Mode (SC) WDM-TX:1550nm/RX:1310nm - 2Km
8	Multi Mode (SC) WDM-TX:1310nm/RX:1550nm - 5Km
9	Multi Mode (SC) WDM-TX:1550nm/RX:1310nm - 5Km
A	Single Mode (SC) - 20Km
B	Single Mode (SC) - 40Km
H	Single Mode (ST) - 20Km
P	Single Mode (SC) WDM-TX:1310nm/RX:1550nm - 20Km
Q	Single Mode (SC) WDM-TX:1550nm/RX:1310nm - 20Km
R	Single Mode (SC) WDM-TX:1310nm/RX:1550nm - 40Km
S	Single Mode (SC) WDM-TX:1550nm/RX:1310nm - 40Km

*More 100FX Fiber options also available upon request.

Optional Accessories

KD-AA78000X	DIN-Rail Mounting Kit
DR-120-48	120W/2.5A DIN-Rail 48VDC Industrial Power Supply (for terminal block)
SDR-240-48	240W/5A DIN-Rail 48VDC Industrial Power Supply (for terminal block)
GS-120A-48	120W/2.5A 48VDC Power Adapter with Latched DC Jack in Plastic Housing

EX27000 Series

IEC61850-3/IEEE1613 Managed 24-port 10/100BASE and 4-port Gigabit Ethernet Switch with SFP options



Overview

EtherWAN's EX27000 Series provides an Industrial Fully Managed 28-port switching platform combining high performance switching backbone with robust and secure management features required for mission critical and industrial environments where sustained connectivity is crucial.

The EX27000 Series is equipped with twenty-four 10/100BASE Fast Ethernet ports, in combination with up to four Gigabit, Fixed Fiber, or SFP Combo port options. Mountable on a 1U rack, the EX27000 Series is equipped with EtherWAN's Alpha-Ring self-healing technology, providing less than 15ms fault recovery time making it ideal for applications intolerant to interruption.

Users are able to access management features such as; port security, IGMP snooping, VLANs, GARP protocols, LACP to name a few, via web browser, Telnet, SNMP, RMON, TFTP, and RS-232 console interfaces.

EtherWAN – "When Connectivity is Crucial."

Spotlight

- **Certified for applications in electric power substations and railway managements**
 - Compliant with IEC61850-3 & IEEE1613, and EN50121-4 standards
- **Redundant power inputs**
 - Supports AC Inlet and DC Terminal Block
- **SFP Options**
 - Supports a list of SFP modules, and the user can flexibly configure each port via SFP module management
- **Fan-less Metal Casing**
 - For easy maintenance with -10°C to 60°C wide operating temperature

Software Features

Management

- Interface
 - CLI, Telnet and Web Browser
 - SNMP v1/v2c/v3
- Firmware and configuration upgrade and backup via TFTP
- Supports DHCP Server/Client
- RMON (Remote monitoring): group 1, 2, 3, 9
- Port mirroring: TX/RX and both
- NTP (Network Time Protocol) time synchronization
- IEEE802.1ab LLDP (Link Layer Discovery Protocol)

Security

- MAC Address by port security
- Enable/disable port
- Storm control (broadcast and multicast types)
- IEEE802.1x LAN access control
- Remote authentication through RADIUS
- SSH for CLI and Telnet security
- SSL for web security
- ACL

Quality of Service (QoS)

- Priority Queues: 4 queues per port
- Traffic classification based on IEEE802.1p CoS, DSCP, WRR (Weighted round robin) and strict mode
- Rate Limiting (Ingress/Egress)

Layer 2 Features

- Auto-negotiation for port speed and duplex mode
- Flow Control
 - IEEE802.3x full duplex mode
 - Back-Pressure half duplex mode
- Redundant Protocol
 - IEEE802.1D Spanning Tree Protocol (STP)
 - IEEE802.1w Rapid Spanning Tree Protocol (RSTP)
 - IEEE802.1s Multiple Spanning Tree Protocol (MSTP)
 - EtherWAN's Alpha-Ring network fault recovery (<15ms) and Alpha-Chain
- VLANs
 - Port-based VLANs
 - IEEE802.1Q Tag VLANs (128 groups, 4096 VID)
 - GVRP (GARP VLAN Registration Protocol)
 - GMRP (GARP Multicast Registration Protocol)
- Link Aggregation
 - Static Trunk (8 groups, support MAC base)
 - IEEE802.3ad Link Aggregation Control Protocol
- IGMP Snooping
 - IGMP snooping v1/v2/v3

Performance

- Switching Capability: 12.8Gbps
- Packet Buffer Size: 3Mbits
- MAC Address Table: 8192

Hardware Specifications

Technology

Standards

- IEEE802.3 10BASE-T
- IEEE802.3u 100BASE-TX/100BASE-FX
- IEEE802.3ab 1000BASE-T
- IEEE802.3z 1000BASE-SX/1000BASE-LX
- IEEE802.3x Full duplex and flow control
- IEEE802.1p QoS
- IEEE802.1Q Tag VLANs
- IEEE802.1w RSTP
- IEEE802.1x Port-based Network Access Control

Forward and Filtering Rate

- 14,880pps for 10Mbps
- 148,810pps for 100Mbps
- 1,488,100pps for 1000Mbps

Packet Buffer Memory

- 3M bits

Processing Type

- Store-and-Forward
- Auto Negotiation
- Half-duplex back-pressure and IEEE802.3x full-duplex flow control
- Auto MDI/MDIX

Address Table Size

- 8192 MAC addresses

Power

Input

- (T) : + / - 48VDC (36 - 75VDC) Internal Universal PSU
- (W) : 88 - 370VDC and 90 - 264VAC Internal Universal PSU
- (C) : 90 - 264VAC, 50 - 60Hz Internal Universal PSU

Power Consumption

- 42.7W Max.

Protection

- Overload current protection

Mechanical

Casing

- Metal Case
- IP30

Dimensions

- Single Power:
442mm (W) x 284mm (D) x 44.2mm (H)
(17.4" (W) x 11.1" (D) x 1.74" (H))
- Redundant Power:
442mm (W) x 360mm (D) x 44.2mm (H)
(17.4" (W) x 14.1" (D) x 1.74" (H))

Weight

- 6.2Kg (13.7lbs)

Installation

- Rack mounting

Interface

Ethernet Port

- 10/100BASE-TX: 24, 20, 16, 12, 8, 4 or 0 port
- 100BASE-FX: 0, 4, 8, 12, 16, 20 or 24 ports
- 100BASE-SFP:0 or 24 ports
- Gigabit: 0, 2 or 4 ports
- Gigabit-SFP Combo: 0 or 4 ports

Console Port

- Port: One DB9 RS-232 port LED Indicators
- Per Unit: Power Status
- Per port 10/100TX and 100FX: Link/Activity (Green)
- Per port 10/100/1000TX, 1000SX/LX: Link/Activity (Green)

LED Indicators

- Port Unit: Power
- Per Port: Link/Act (Green)

Environment

Operating Temperature

- -10°C to 60°C (14°F to 140°F)
Tested @ -20°C to 70°C (-4°F to 158°F)

Storage Temperature

- -40°C to 85°C (-40°F to 185°F)

Ambient Relative Humidity

- 5% to 95% (non-condensing)

Regulatory Approvals

ISO

- Manufactured in an ISO9001 facility

EMI

FCC Part 15B, Class A

EN61000-6-4

EN55022

EN61000-3-2

EN61000-3-3

EMS

EN61000-6-2

- EN61000-4-2 (ESD Standards)
- EN61000-4-3 (Radiated RFI Standards)
- EN61000-4-4 (Burst Standards)
- EN61000-4-5 (Surge Standards)
- EN61000-4-6 (Induced RFI Standards)
- EN61000-4-8 (Magnetic Field Standards)
- IEC61000-4-10 (Oscillatory wave magnetic field test)
- IEC61000-4-16 (Power frequency immunity test)
- IEC61000-4-18 (Oscillatory wave immunity test)

Environmental Test Compliance

IEC60068-2-6 Fc (Vibration)

IEC60068-2-27 Ea (Shock)

FED STD 101C Method 5007.1 (Free fall w/ package)

Industrial Compliance

IEC61850-3 / IEEE1613

EN50121-4

Application Diagram

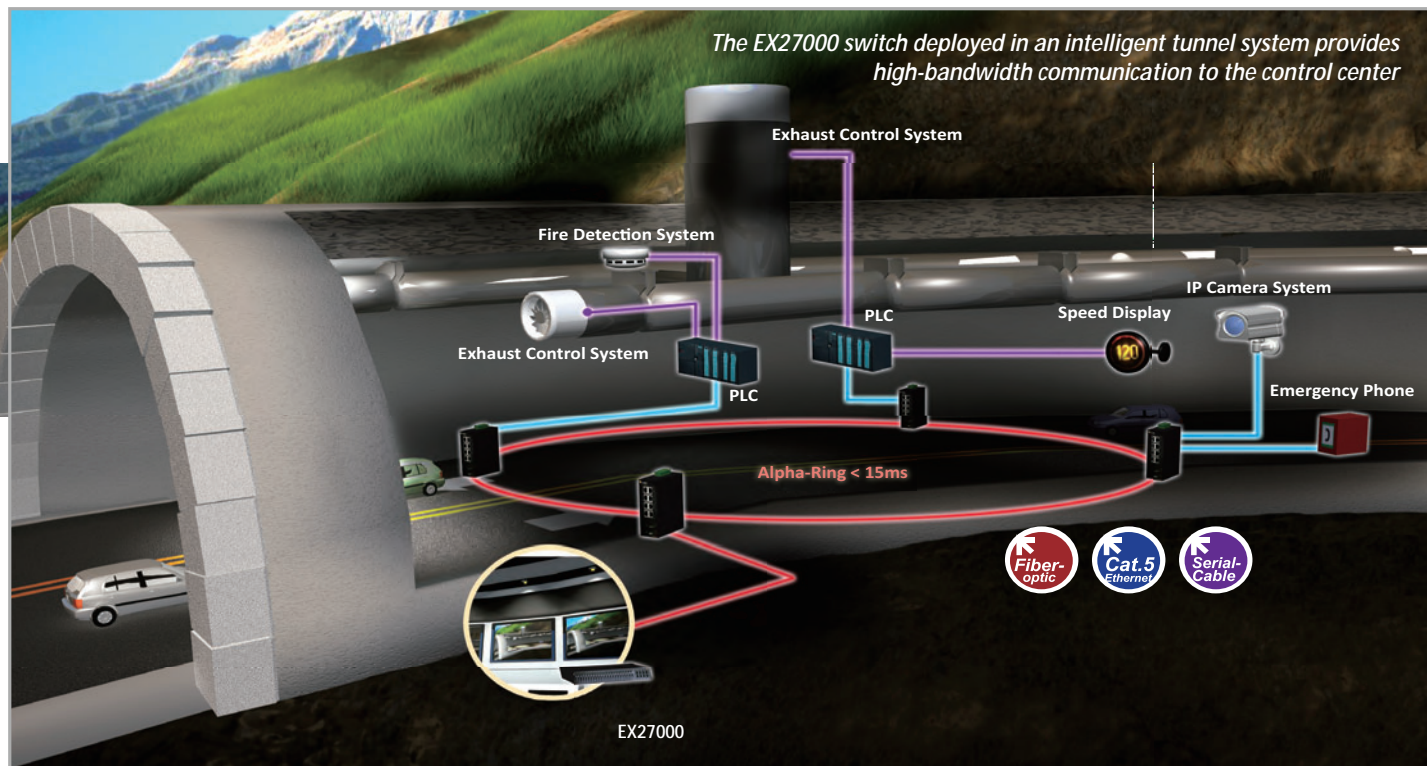

Dimensions

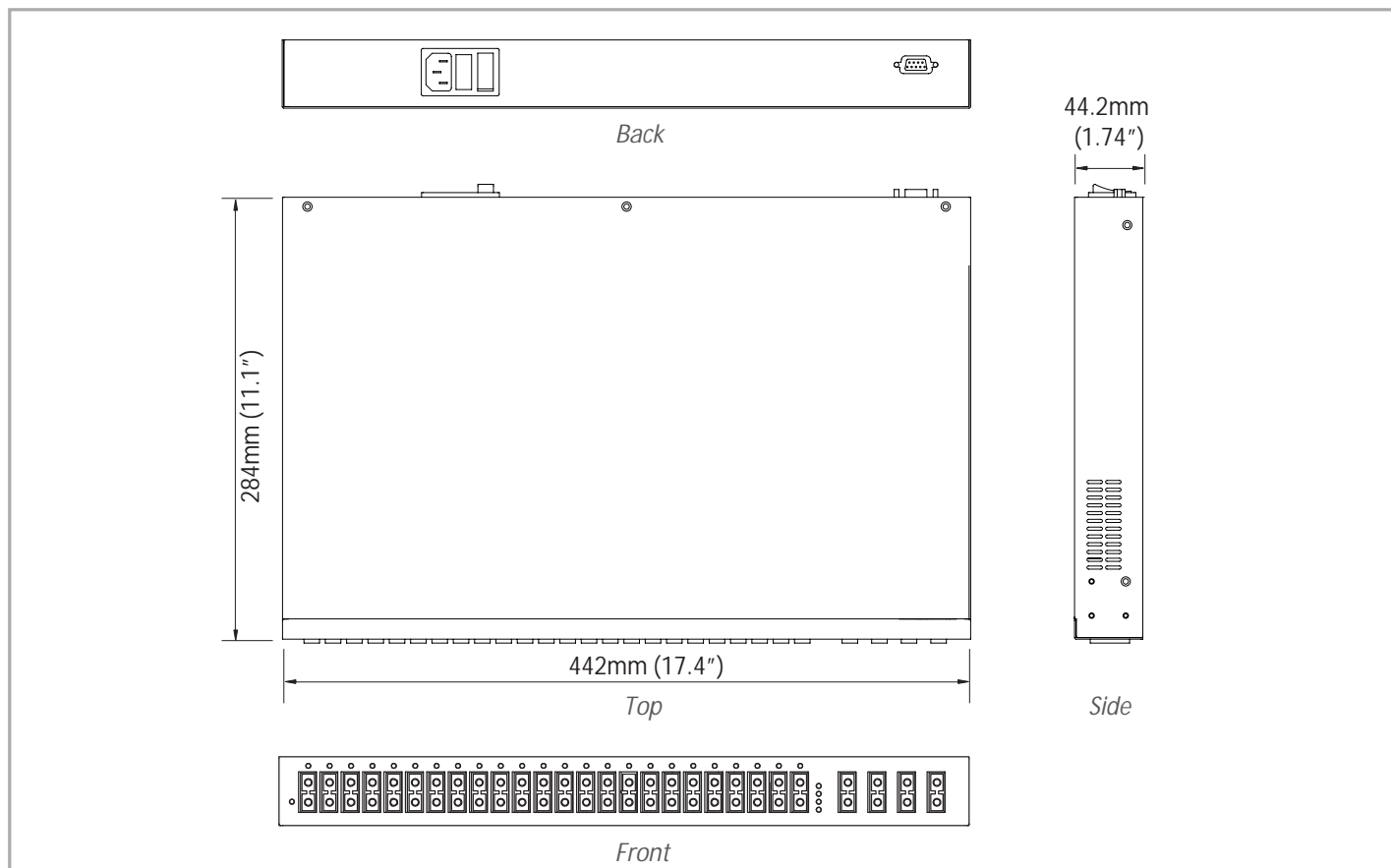

Ordering Information

Model

EX27604-0XYZ	24-port 10/100BASE-TX + 4-port Gigabit Managed Ethernet Switch
EX27424-WXYZ	16-port 10/100BASE-TX + 8-port 100BASE-FX + 4-port Gigabit Managed Ethernet Switch
EX27244-WXYZ	8-port 10/100BASE-TX + 16-port 100BASE-FX + 4-port Gigabit Managed Ethernet Switch
EX27064-WXYZ	24-port 100BASE-FX + 4-port Gigabit Managed Ethernet Switch
EX27064-V0VZ	24-port 100BASE-SFP + 4-port Gigabit SFP Combo Managed Ethernet Switch

* Rack mounting kit included

100FX Fiber Options (W)

1	Multi Mode (SC) - 2Km
2	Multi Mode (ST) - 2Km
6	Multi Mode (SC) WDM-TX:1310nm/RX:1550nm - 2Km
7	Multi Mode (SC) WDM-TX:1550nm/RX:1310nm - 2Km
8	Multi Mode (SC) WDM-TX:1310nm/RX:1550nm - 5Km
9	Multi Mode (SC) WDM-TX:1550nm/RX:1310nm - 5Km
A	Single Mode (SC) - 20Km
B	Single Mode (SC) - 40Km
F	Single Mode (FC) - 20Km
H	Single Mode (ST) - 20Km
P	Single Mode (SC) WDM-TX:1310nm/RX:1550nm - 20Km
Q	Single Mode (SC) WDM-TX:1550nm/RX:1310nm - 20Km
R	Single Mode (SC) WDM-TX:1310nm/RX:1550nm - 40Km
S	Single Mode (SC) WDM-TX:1550nm/RX:1310nm - 40Km

Number of Fixed Gigabit Fibers (X)

0	None
1	One Gigabit fiber port
2	Two Gigabit fiber ports
3	Three Gigabit fiber ports
4	Four Gigabit fiber ports

Gigabit Port Options (Y)

1	10/100/1000BASE-TX
3	1000BASE-SX(SC) - 550m
4	1000BASE-SX (SC) - 2Km
A	1000BASE-LX (SC) - 10Km
B	1000BASE-LX (SC) - 20Km
R	1000BASE-BX (SC) WDM-TX:1310nm/RX:1550nm - 20Km
S	1000BASE-BX (SC) WDM-TX:1550nm/RX:1310nm - 20Km
V	4-port 1000BASE SFP Combo with 10/100/1000BASE-TX

*More Gigabit options also available upon request.

Ordering Information - continued

Power Input Interface (Z)

T	± 48VDC (Terminal Block)
W	88 - 370VDC and 90 - 264VAC (Terminal Block)
C	90 - 264VAC (AC Inlet)
TR	± 48VDC Redundant (Terminal Block)
WR	88 - 370VDC and 90 - 264VAC Redundant (Terminal Block)
CR	90 - 264VAC Redundant (AC Inlet)

EX29000 Series

IEC61850-3/IEEE1613 Modulized Managed 24-port 10/100BASE and 4-port Gigabit Ethernet Switch with SFP options



Overview

EtherWAN's EX29000 Series provides an industrial Fully Managed 28-port switching platform combining high performance switching backbone with robust and secure management features required for mission critical and industrial environments where sustained connectivity is crucial.

Highly modularized, the EX29000 switch supports up to 28 electrical and/or optical interfaces with data transfer rates of 10/100 Mbit/s and up to four Gigabit, Fixed Fiber, or SFP Combo port options. Mountable on a 1U rack, the EX29000 Series is equipped with EtherWAN's Alpha-Ring self-healing technology, providing less than 15ms fault recovery time making it ideal for applications intolerant to interruption.

Users are able to access management features such as port security, IGMP snooping, VLANs, GARP protocols, LACP to name a few via web browser, Telnet, SNMP, RMON, TFTP, and RS-232 console interface.

EtherWAN – "When Connectivity is Crucial."

Spotlight

• Versatile Connectivity

- Modularized Ethernet Switch of 24-port 10/100BASE-TX/FX/BX and 4-port Gigabit-TX/SX/LX/BX/SFP

• Hardened Grade

- Wide operating temperature range for extreme environments
- Fanless and ruggedized housing
- High shock and electric noise immunity

• IEC61850-3 Compliance

- Meets the standards for operating in power substation zones

Software Features

Management

- Interface
 - CLI, Telnet and Web Browser
 - SNMP v1/v2c/v3
- Firmware and configuration upgrade and backup via TFTP
- Supports DHCP Server/Client
- RMON (Remote monitoring): group 1, 2, 3, 9
- Port mirroring: TX/RX and both
- SFP transceivers support Digital Diagnostics Monitoring (DDM)
- NTP (Network Time Protocol) time synchronization

Security

- MAC Address by port security
- Enable/disable port
- Storm control (broadcast and multicast types)
- IEEE802.1x LAN access control
- Remote authentication through RADIUS

Quality of Service (QoS)

- Priority Queues: 4 queues per port
- Traffic classification based on IEEE802.1p CoS, DSCP, WRR (Weighted Round Robin) and strict mode
- Rate Limiting (Ingress/Egress)

Layer 2 Features

- Auto-negotiation for port speed and duplex mode
- Flow Control
 - IEEE802.3x full duplex mode
 - Back-Pressure half duplex mode
- Redundant Protocol
 - IEEE802.1D Spanning Tree Protocol (STP)
 - IEEE802.1w Rapid Spanning Tree Protocol (RSTP)
 - IEEE802.1s Multiple Spanning Tree Protocol (MSTP)
 - EtherWAN's Alpha-Ring network fault recovery (<15ms) and Alpha-Chain
- VLANs
 - Port-based VLANs
 - IEEE802.1Q Tag VLANs (128 groups, 4096 VID)
 - GVRP (GARP VLAN Registration Protocol)
 - GMRP (GARP Multicast Registration Protocol)
- Link Aggregation
 - Static Trunk (8 groups, support MAC base)
 - IEEE802.3ad Link Aggregation Control Protocol
- IGMP Snooping
 - IGMP snooping v1/v2/v3

Performance

- Switching Capability: 12.8Gbps
- Packet Buffer Size: 3Mbits
- MAC Address Table: 8K

Hardware Specifications

Technology

Standards

- IEEE802.3 10BASE-T
- IEEE802.3u 100BASE-TX/100BASE-FX
- IEEE802.3ab 1000BASE-T
- IEEE802.3z 1000BASE-SX/1000BASE-LX
- IEEE802.3x Full duplex and flow control
- IEEE802.1p QoS
- IEEE802.1Q Tag VLANs
- IEEE802.1w RSTP
- IEEE802.1x Port-based Network Access Control

Forward and Filtering Rate

- 14,880pps for 10Mbps
- 148,810pps for 100Mbps
- 1,488,100pps for 1000Mbps

Packet Buffer Memory

- 3M bits

Processing Type

- Store-and-Forward
- Half-duplex back-pressure and IEEE802.3x full-duplex flow control

Address Table Size

- 8192 MAC addresses

Power

Input

- (T) : + / - 48VDC (36 - 75VDC) Internal Universal PSU
- (W) : 88 - 370VDC and 90 - 264VAC Internal Universal PSU
- (C) : 90 - 264VAC, 50 - 60Hz Internal Universal PSU

Power Consumption

- 42.7W Max.

Protection

- Overload current protection

Mechanical

Casing

- Metal Case
- IP30

Dimensions

- Single Power:
442mm (W) x 343mm (D) x 44.2mm (H)
17.4" (W) x 13.5" (D) x 1.74" (H)
- Redundant Power:
442mm (W) x 404mm (D) x 44.2mm (H)
(17.4" (W) x 15.9" (D) x 1.74" (H))

Weight

- Single Power: 4.4Kg (9.68lbs.)
- Redundant Power: 4.6 kg (10.1 lbs.)

Installation

- Rack mounting

Interface

Ethernet Port

- 10/100BASE-TX: 24, 16, 8 or 0 port
- 100BASE-FX: 0, 4, 8, 12, 16, 20 or 24 ports
- Gigabit: 0, 2 or 4 portss

Console Port

- Port: One DB9 RS-232 port

LED Indicators

- Per Unit: Power
- Per Port: Link/Act (Green)
- Per SFP Slot: Selected/Unselected (Green)

Environment

Operating Temperature

- -10°C to 60°C (14°F to 140°F)
Tested @ -20°C to 70°C (-4°F to 158°F)

Storage Temperature

- -40°C to 85°C (-40°F to 185°F)

Ambient Relative Humidity

- 5% to 95% (non-condensing)

Regulatory Approvals

ISO

- Manufactured in an ISO9001 facility

EMI

FCC Part 15B, Class A

EN61000-6-4

EN55022

EN61000-3-2

EN61000-3-3

EMS

EN61000-6-2

- EN61000-4-2 (ESD Standards)
- EN61000-4-3 (RFI Standards)
- EN61000-4-4 (Burst Standards)
- EN61000-4-5 (Surge Standards)
- EN61000-4-6 (Induced RFI Standards)
- EN61000-4-8 (Magnetic Field Standards)
- IEC61000-4-10 (Oscillatory wave magnetic field test)
- IEC61000-4-16 (Power frequency immunity test)
- IEC61000-4-18 (Oscillatory wave immunity test)

Environmental Test Compliance

IEC60068-2-6 Fc (Vibration Resistance)

IEC60068-2-27 Ea (Shock)

Industrial Compliance

IEC61850-3 / IEEE1613

Application Diagram

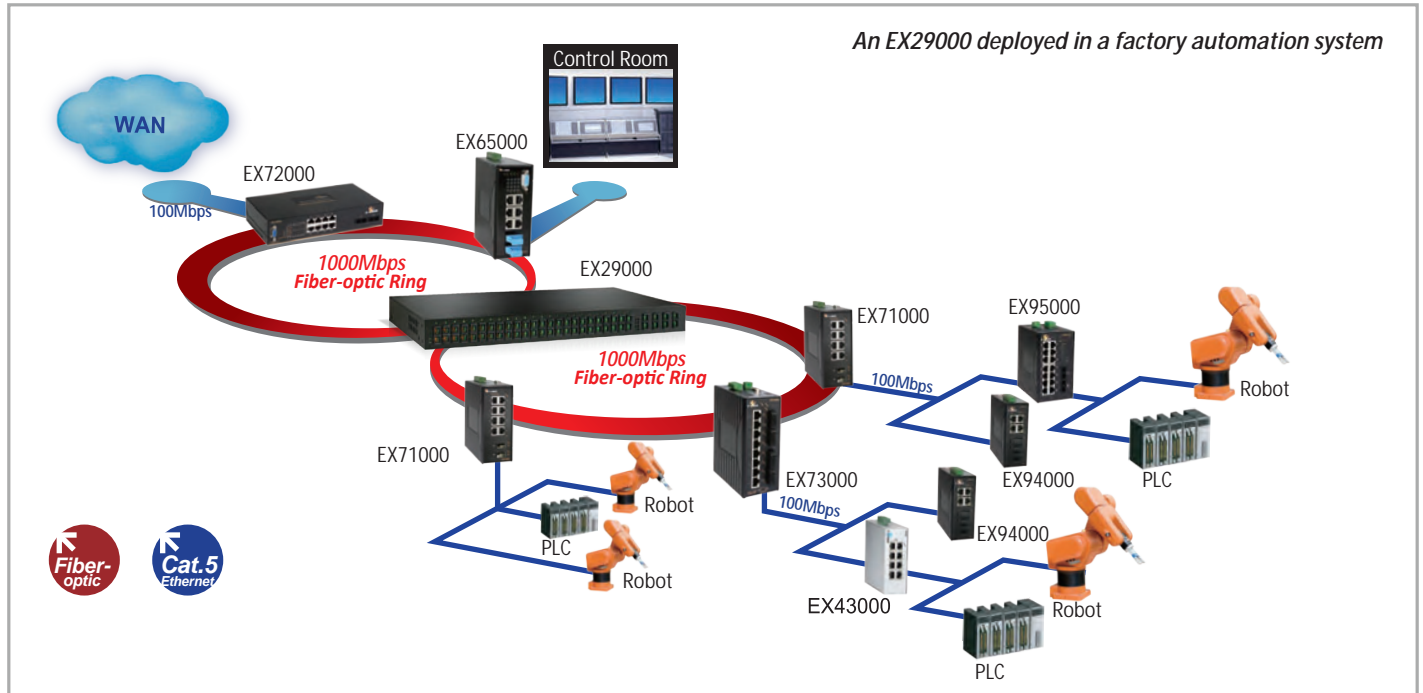

Dimensions

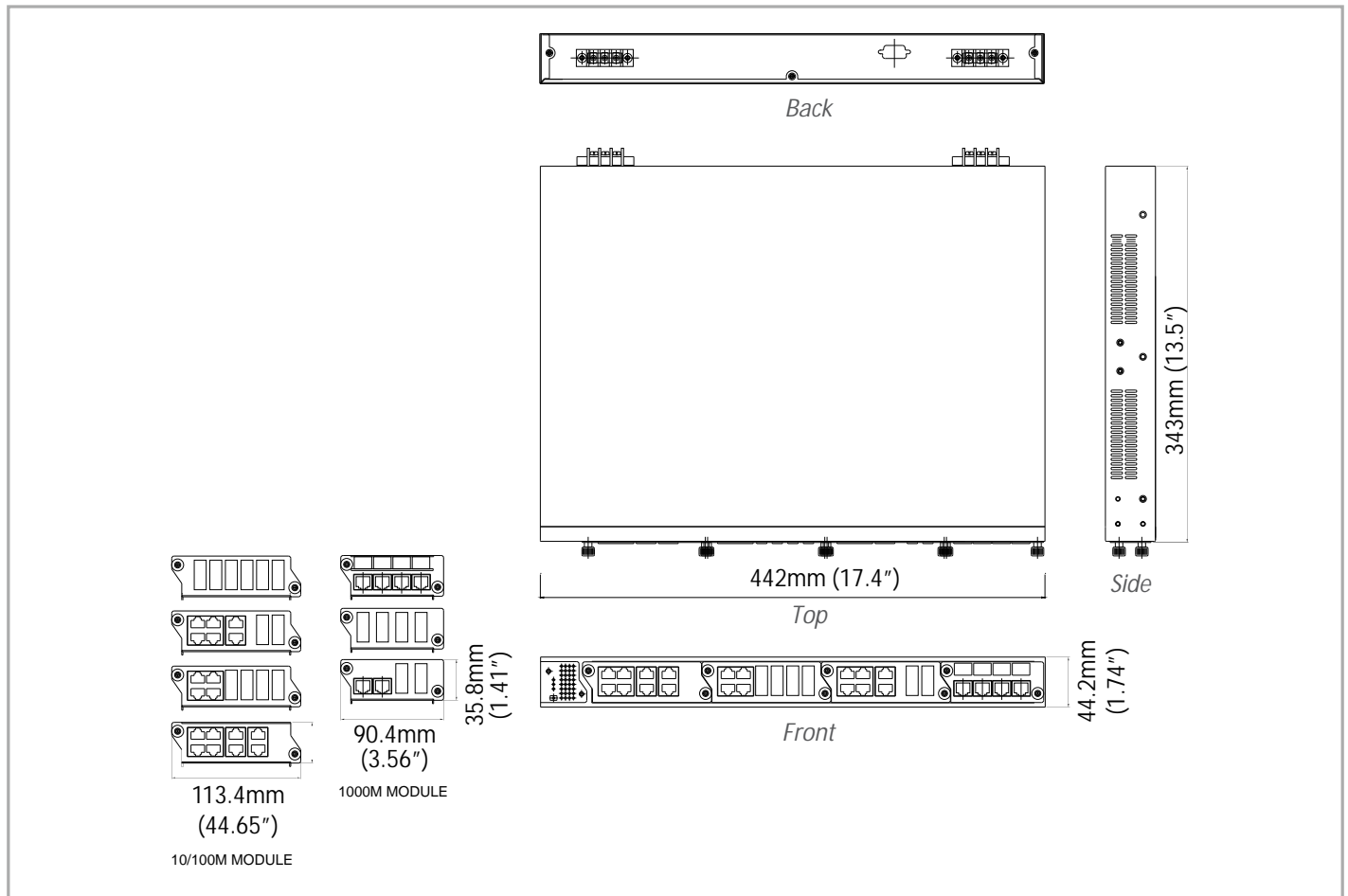

Ordering Information

Model

EX29000-00Z	IEC61850-3/IEEE1613 Modulized Managed 24-port 10/100BASE and 4-port Gigabit Ethernet Switch with SFP options
-------------	--

* Rack mounting kit included

Modules for EX29000 Series

Model	Description	Slot 1	Slot 2	Slot 3	Slot 4
M29800-000	8-Port 10/100BASE TX	✓	✓	✓	
M29620-W00	6-Port 10/100BASE TX + 2-Port 100BASE FX	✓	✓	✓	
M29420-W00	4-Port 10/100BASE TX + 2-Port 100BASE FX	✓	✓	✓	
M29060-W00	6-Port 10/100BASE FX	✓	✓	✓	
M29240-W00	2-Port 10/100BASE TX + 4-Port 100BASE FX	✓	✓	✓	
M29440-W00	4-Port 10/100BASE TX + 4-Port 100BASE FX	✓	✓	✓	
M29004-OXY	4-Port Gigabit				✓

Gigabit Port Options (Y)

1	10/100/1000BASE-TX
3	1000BASE-SX (SC) - 550m
4	1000BASE-SX (SC) - 2Km
5	1000BASE-SX (ST) - 550m
A	1000BASE-LX (SC) - 10Km
B	1000BASE-LX (SC) - 20Km
R	1000BASE-BX (SC) WDM-TX:1310nm/RX: 1550nm - 20Km
S	1000BASE-BX (SC) WDM-TX:1550nm/RX: 1310nm - 20Km
V	4-port 1000BASE SFP Combo with 10/100/1000BASE-TX

* More Gigabit options also available upon request.

100FX Fiber Options (W)

1	Multi Mode (SC) - 2Km
2	Multi Mode (ST) - 2Km
6	Multi Mode (SC) WDM-TX:1310nm/RX:1550nm - 2Km
7	Multi Mode (SC) WDM-TX:1550nm/RX:1310nm - 2Km
8	Multi Mode (SC) WDM-TX:1310nm/RX:1550nm - 5Km
9	Multi Mode (SC) WDM-TX:1550nm/RX:1310nm - 5Km
A	Single Mode (SC) - 20Km
B	Single Mode (SC) - 40Km
H	Single Mode (ST) - 20Km
P	Single Mode (SC) WDM-TX:1310nm/RX:1550nm - 20Km
Q	Single Mode (SC) WDM-TX:1550nm/RX:1310nm - 20Km
R	Single Mode (SC) WDM-TX:1310nm/RX:1550nm - 40Km
S	Single Mode (SC) WDM-TX:1550nm/RX:1310nm - 40Km

Number of Fixed Gigabit Fibers (X)

0	None
4	Four Gigabit fiber ports

**More Gigabit options also available upon request.*

Power Input Interface (Z)

T	± 48VDC (Terminal Block)
W	88 - 370VDC and 90 - 264VAC (Terminal Block)
C	90 - 264VAC (AC Inlet)
TR	± 48VDC Redundant (Terminal Block)
WR	88 - 370VDC and 90 - 264VAC Redundant (Terminal Block)
CR	90 - 264VAC Redundant (AC Inlet)

EX63000 Series

Industrial Managed 16-port 10/100BASE with 2-port Gigabit combo Ethernet Switch



Overview

EtherWAN's EX63000 Series provides an industrial Fully Managed 18-port switching platform combining high performance switching backbone with robust and secure management features required for mission critical and harsh environments where sustained connectivity is crucial.

The EX63000 Series is equipped with sixteen 10/100BASE Fast Ethernet ports, in combination with up to two Gigabit combo ports with Fixed Fiber options. Mountable on a DIN-rail, the EX63000 Series is equipped with EtherWAN's Alpha-Ring self-healing technology, providing less than 15ms fault recovery time making it ideal for applications intolerant to interruption.

Users are able to access management features such as; port security, IGMP snooping, VLANs, GARP protocols, LACP, and via web browser, Telnet, SNMP, RMON, TFTP, and RS-232 console interfaces.

EtherWAN - "When Connectivity is Crucial."

Spotlight

• Versatile Connectivity

- Provides 16-port 10/100BASE-TX/FX/BX/SFP plus 2-port Gigabit-SX/LX/BX/SFP combo

• Hardened Grade

- Wide operating temperature range from -10°C to 60°C (-14°F to 140°F) for extreme environments
- Fanless and ruggedized housing

• Secure Remote Access

- IEEE802.1x, and RADIUS support

Software Features

Management

- Interface
 - CLI, Telnet and web browser
 - SNMP v1/v2c/v3
- Firmware and configuration upgrade and backup via TFTP
- Supports DHCP Server/Client
- RMON (Remote monitoring): group 1, 2, 3, 9
- Port mirroring: TX/RX and both
- NTP (Network Time Protocol) time synchronization
- IEEE802.1ab LLDP (Link Layer Discovery Protocol)

Security

- MAC address filtering
- Enable/disable port
- Storm control (broadcast and multicast types)
- IEEE802.1x LAN access control
- Remote authentication through RADIUS
- SSH for CLI and Telnet security
- SSL for web security
- Multi-level user account/password against unauthorized configuration
- System log (remote/local)

Quality of Service (QoS)

- Priority Queues: 4 queues per port
- Traffic classification based on IEEE802.1p CoS, DSCP, WRR (Weighted round robin) and strict mode
- Rate Limiting (Ingress/Egress)

Layer 2 Features

- Auto-negotiation for port speed and duplex mode
- Flow Control
 - IEEE802.3x full duplex mode
 - Back-Pressure half duplex mode
- Redundant Protocol
 - IEEE802.1D Spanning Tree Protocol (STP)
 - IEEE802.1w Rapid Spanning Tree Protocol (RSTP)
 - IEEE802.1s Multiple Spanning Tree Protocol (MSTP)
- VLANs
 - Port-based VLANs
 - IEEE802.1Q Tag VLANs (128 groups, 4096 VID)
 - GVRP (GARP VLAN Registration Protocol)
 - GMRP (GARP Multicast Registration Protocol)
- Link Aggregation
 - Static Trunk (2 groups, support MAC base)
 - IEEE802.3ad Link Aggregation Control Protocol
- IGMP Snooping
 - IGMP snooping v1/v2/v3

Performance

- Switching Capability: 7.2Gbps
- Packet Buffer Size: 2M bits
- MAC Address Table: 8192

Hardware Specifications

Technology

Standards

- IEEE802.3 10BASE-T
- IEEE802.3u 100BASE-TX/100BASE-FX
- IEEE802.3ab 1000BASE-T
- IEEE802.3z 1000BASE-SX/1000BASE-LX
- IEEE802.3x Full duplex and flow control
- IEEE802.1p QoS
- IEEE802.1Q Tag VLANs
- IEEE802.1w RSTP
- IEEE802.1x Port-based Network Access Control

Forward and Filtering Rate

- 14,880pps for 10Mbps
- 148,810pps for 100Mbps
- 1,488,100pps for 1000Mbps

Packet Buffer Memory

- 2M bits

Processing Type

- Store-and-Forward
- Auto Negotiation
- Half-duplex back-pressure and IEEE802.3x full-duplex flow control
- Auto MDI/MDIX

Address Table Size

- 8192 MAC addresses

Power

Input

- Redundant power inputs:
 - 12 - 48VDC (Terminal Block) ,
 - 12VDC (DC Jack)

Power Consumption

- 15W Max. 1.25A @ 12VDC, 0.625A @ 24VDC

Protection

- Overload current protection
- Reverse polarity protection

Mechanical

Casing

- Metal Case
- IP30

Dimensions

- 59mm (W) x 125mm (D) x145mm (H)
(2.32" (W) x 4.92" (D) x 5.71" (H))

Weight

- 1Kg (2.2lbs.)

Installation

- DIN-Rail (Top hat type 35mm) or Wall mounting

Interface

Ethernet Port

- 10/100BASE-TX: 16, 12 or 8 ports
- 100BASE-FX: 0, 1, 2 or 4 ports
- Gigabit: 0, 1 or 2 ports

Console Port

- Port: One DB9 RS-232 port

LED Indicators

- Per Unit: Power 1, Power 2, Power 3
- Per Port: Link/Activity
(Green: Copper; Orange: Fiber)

Alarm Contact

- One relay output with current 1A @ 24VDC

Environment

Operating Temperature

- -10°C to 60°C (-14°F to 140°F)
Tested @ -20°C to 70°C (-4°F to 158°F)

Storage Temperature

- -45°C to 85°C (-49°F to 185°F)

Ambient Relative Humidity

- 5% to 95% (non-condensing)

Regulatory Approvals

ISO

- Manufactured in an ISO9001 facility

EMI

FCC Part 15B, Class A

EN61000-6-4

EN55022

EN61000-3-2

EN61000-3-3

EMS

EN61000-6-2

- EN61000-4-2 (ESD Standards)
- EN61000-4-3 (Radiated RFI Standards)
- EN61000-4-4 (Burst Standards)
- EN61000-4-5 (Surge Standards)
- EN61000-4-6 (Induced RFI Standards)
- EN61000-4-8 (Magnetic Field Standards)

Environmental Test Compliances

IEC60068-2-6 Fc (Vibration Resistance)

IEC60068-2-27 Ea (Shock)

FED STD 101C Method 5007.1 (Free fall w/ package)

Application Diagram

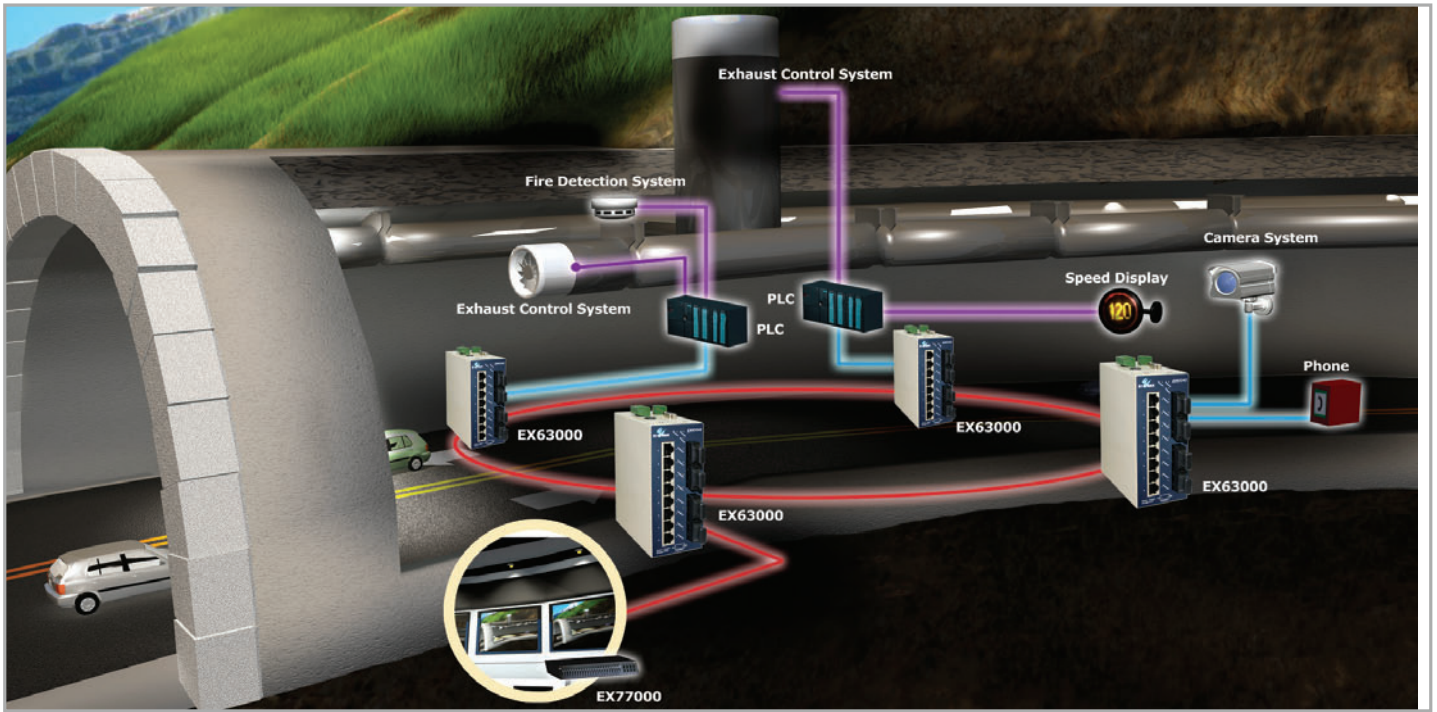

Dimensions

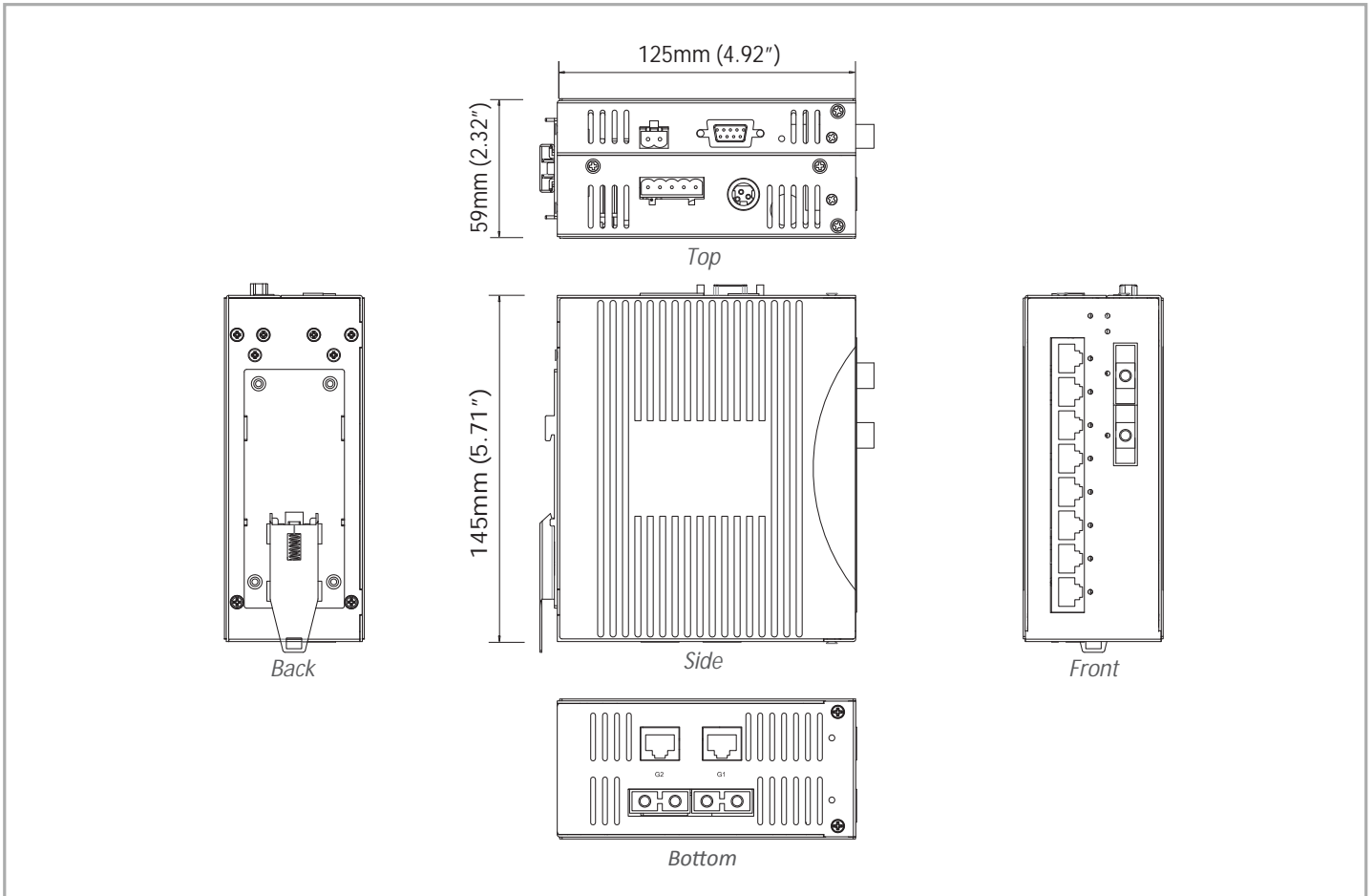

Ordering Information

Model

EX63400-00B	16-port 10/100BASE-TX Industrial Managed Ethernet Switch
EX63401-0YB	16-port 10/100BASE-TX + 1-port Gigabit Industrial Managed Ethernet Switch
EX63402-0YB	16-port 10/100BASE-TX + 2-port Gigabit Industrial Managed Ethernet Switch
EX63310-X0B	12-port 10/100BASE-TX + 1-port 100BASE-FX Industrial Managed Ethernet Switch
EX63311-XYB	12-port 10/100BASE-TX + 1-port 100BASE-FX + 1-port Gigabit Industrial Managed Ethernet Switch
EX63312-XYB	12-port 10/100BASE-TX + 1-port 100BASE-FX + 2-port Gigabit Industrial Managed Ethernet Switch
EX63320-X0B	12-port 10/100BASE-TX + 2-port 100BASE-FX Industrial Managed Ethernet Switch
EX63321-XYB	12-port 10/100BASE-TX + 2-port 100BASE-FX + 1-port Gigabit Industrial Managed Ethernet Switch
EX63322-XYB	12-port 10/100BASE-TX + 2-port 100BASE-FX + 2-port Gigabit Industrial Managed Ethernet Switch
EX63200-00B	8-port 10/100BASE-TX Industrial Managed Ethernet Switch
EX63201-0YB	8-port 10/100BASE-TX + 1-port Gigabit Industrial Managed Ethernet Switch
EX63202-0YB	8-port 10/100BASE-TX + 2-port Gigabit Industrial Managed Ethernet Switch
EX63210-X0B	8-port 10/100BASE-TX + 1-port 100BASE-FX Industrial Managed Ethernet Switch
EX63211-XYB	8-port 10/100BASE-TX + 1-port 100BASE-FX + 1-port Gigabit Industrial Managed Ethernet Switch
EX63212-XYB	8-port 10/100BASE-TX + 1-port 100BASE-FX + 2-port Gigabit Industrial Managed Ethernet Switch
EX63220-X0B	8-port 10/100BASE-TX + 2-port 100BASE-FX Industrial Managed Ethernet Switch
EX63221-XYB	8-port 10/100BASE-TX + 2-port 100BASE-FX + 1-port Gigabit Industrial Managed Ethernet Switch
EX63222-XYB	8-port 10/100BASE-TX + 2-port 100BASE-FX + 2-port Gigabit Industrial Managed Ethernet Switch
EX63240-X0B	8-port 10/100BASE-TX + 4-port 100BASE-FX Industrial Managed Ethernet Switch
EX63241-XYB	8-port 10/100BASE-TX + 4-port 100BASE-FX + 1-port Gigabit Industrial Managed Ethernet Switch
EX63242-XYB	8-port 10/100BASE-TX + 4-port 100BASE-FX + 2-port Gigabit Industrial Managed Ethernet Switch

* DIN-Rail mounting kit included

100FX Fiber Options (X)

1	Multi Mode (SC) - 2Km
2	Multi Mode (ST) - 2Km
6	Multi Mode (SC) WDM-TX:1310nm/RX:1550nm - 2Km
7	Multi Mode (SC) WDM-TX:1550nm/RX:1310nm - 2Km
8	Multi Mode (SC) WDM-TX:1310nm/RX:1550nm - 5Km
9	Multi Mode (SC) WDM-TX:1550nm/RX:1310nm - 5Km
A	Single Mode (SC) - 20Km
B	Single Mode (SC) - 40Km
H	Single Mode (ST) - 20Km
P	Single Mode (SC) WDM-TX:1310nm/RX:1550nm - 20Km
Q	Single Mode (SC) WDM-TX:1550nm/RX:1310nm - 20Km
R	Single Mode (SC) WDM-TX:1310nm/RX:1550nm - 40Km
S	Single Mode (SC) WDM-TX:1550nm/RX:1310nm - 40Km

Ordering Information - continued

Gigabit Port Options (Y)

1	10/100/1000BASE-TX (No Gigabit Fiber port supported)
3	Combo port: 10/100/1000BASE-TX with 1000BASE-SX (SC) - 550m
4	Combo port: 10/100/1000BASE-TX with 1000BASE-SX (SC) - 2Km
5	Combo port: 10/100/1000BASE-TX with 1000BASE-SX (ST) - 550m
A	Combo port: 10/100/1000BASE-TX with 1000BASE-LX (SC) - 10Km
B	Combo port: 10/100/1000BASE-TX with 1000BASE-LX (SC) - 20Km
R	Combo port: 10/100/1000BASE-TX with 1000BASE-BX (SC) WDM-TX:1310nm/RX:1550nm - 20Km
S	Combo port : 10/100/1000BASE-TX with 1000BASE-LX (SC) WDM-TX:1550nm/RX: 1310nm - 20Km

Optional Accessories

KP-AA96-480	Panel Mounting Kits
DR-30-24	30W/1.5A DIN-Rail 24VDC Industrial Power Supply (for Terminal Block)
DR-60--24	60W/2.5A DIN-Rail 24VDC Industrial Power Supply (for Terminal Block)
DR-120-24	120W/5A DIN-Rail 24VDC Industrial Power Supply (for Terminal Block)
41-136046-X	36W/3A 12VDC hardened power adapter with open wire in aluminum housing (for Terminal Block); (X) = 1: US, 2: EU, 3: UK, 4: AU, 5: JP, 6: SA
41-136044-X	36W/3A 12VDC hardened power adapter with latched DC Jack in aluminum housing (for DC Jack); (X) = 1: US, 2: EU, 3: UK, 4: AU, 5: JP, 6: SA

EX61000A Series

Industrial Managed 8-port 10/100BASE and 2-port Gigabit Ethernet Switch with SFP options



Overview

EtherWAN's EX61000A Series provides an industrial Fully Managed 10-port switching platform combining high performance switching backbone with robust and secure management features required for mission critical and harsh environments where sustained connectivity is crucial.

The EX61000A Series is equipped with ten 10/100BASE Fast Ethernet ports, or a combination with up to two Gigabit, Fixed Fiber, or SFP port options. Mountable on a DIN-rail, the EX61000A Series is equipped with EtherWAN's Alpha-Ring self-healing technology, providing less than 15ms fault recovery time making it ideal for applications intolerant to interruption.

Users are able to access management features such as; port security, IGMP snooping, VLANs, GARP protocols, LACP, and via web browser, Telnet, SNMP, RMON, TFTP, and RS-232 console interfaces.

EtherWAN — "When Connectivity is Crucial."

Spotlight

• Versatile Connectivity

- Provides 8-port 10/100BASE-TX/FX/BX/SFP plus 2-port Gigabit-SX/LX/BX/SFP

• Hardened Grade

- Operating temperature range from -10°C to 60°C (-14°F to 140°F) for industrial environments
- Fanless and ruggedized housing

• Secure Remote Access

- IEEE802.1x and RADIUS support

Software Features

Management

- Interface
 - CLI, Telnet and Web Browser
 - SNMP v1/v2c/v3
- Firmware and configuration upgrade and backup via TFTP
- Supports DHCP Server/Client
- RMON (Remote monitoring): group 1, 2, 3, 9
- Port mirroring: TX/RX and both
- NTP (Network Time Protocol) time synchronization
- IEEE802.1ab LLDP (Link Layer Discovery Protocol)

Security

- MAC address filtering
- Enable/disable port
- Storm control (broadcast and multicast types)
- IEEE802.1x LAN access control
- Remote authentication through RADIUS
- SSH for CLI and Telnet security
- SSL for web security
- Multi-level user account/password against unauthorized configuration
- System log (remote/local)

Quality of Service (QoS)

- Priority Queues: 4 queues per port
- Traffic classification based on IEEE802.1p CoS, DSCP, WRR (Weighted round robin) and strict mode
- Rate Limiting (Ingress/Egress)

Layer 2 Features

- Auto-negotiation for port speed and duplex mode
- Flow Control
 - IEEE802.3x full duplex mode
 - Back-Pressure half duplex mode
- Redundant Protocol
 - IEEE802.1D Spanning Tree Protocol (STP)
 - IEEE802.1w Rapid Spanning Tree Protocol (RSTP)
 - IEEE802.1s Multiple Spanning Tree Protocol (MSTP)
 - EtherWAN's Alpha-Ring network fault recovery (<15ms)
- VLANs
 - Port-based VLANs
 - IEEE802.1Q Tag VLANs (128 groups, 4096 VID)
 - GVRP (GARP VLAN Registration Protocol)
 - GMRP (GARP Multicast Registration Protocol)
- Link Aggregation
 - Static Trunk (2 groups, support MAC base)
 - IEEE802.3ad Link Aggregation Control Protocol
- IGMP Snooping
 - IGMP snooping v1/v2/v3

Performance

- Switching Capability: 5.6Gbps
- Packet Buffer Size: 2M bits
- MAC Address Table: 8192

Hardware Specifications

Technology

Standards

- IEEE802.3 10BASE-T
- IEEE802.3u 100BASE-TX/100BASE-FX
- IEEE802.3ab 1000BASE-T
- IEEE802.3z 1000BASE-SX/1000BASE-LX
- IEEE802.3x Full duplex and flow control
- IEEE802.1p QoS
- IEEE802.1Q Tag VLANs
- IEEE802.1w RSTP
- IEEE802.1x Port-based Network Access Control

Forward and Filtering Rate

- 14,880pps for 10Mbps
- 148,810pps for 100Mbps
- 1,488,100pps for 1000Mbps

Packet Buffer Memory

- 2M bits

Processing Type

- Store-and-Forward
- Auto Negotiation
- Half-duplex back-pressure and IEEE802.3x full-duplex flow control
- Auto MDI/MDIX

Address Table Size

- 8192 MAC addresses

Power

Input

- Redundant power inputs:
 - 12 - 48VDC (Terminal Block)
 - 12VDC (DC Jack)

Power Consumption

- 11W Max. 0.92A @ 12VDC, 0.46A @ 24VDC

Protection

- Overload current protection
- Reverse polarity protection

Mechanical

Casing

- Aluminum Case
- IP30

Dimensions

- 60mm (W) x 125mm (D) x 145mm (H)
(2.36" (W) x 4.92" (D) x 5.7" (H))

Weight

- 1.1Kg (2.42lbs.)

Installation

- DIN-Rail (Top hat type 35mm), Rack, or Wall mounting

Interface

Ethernet Port

- 10/100BASE-TX: 8, 6 or 4 port
- 100BASE-FX: 0 to 4 ports
- Gigabit: 0, 1 or 2 ports

Console Port

- Port: One DB9 RS-232 port

LED Indicators

- Per Unit: Power 1, Power 2, Power 3
- Per Port: Link/Activity, Speed

Alarm Contact

- One relay output with current 1A @ 24VDC

Environment

Operating Temperature

- -40°C to 75°C (-40°F to 167°F)
Tested @ -40°C to 85°C (-40°F to 185°F)

Storage Temperature

- -40°C to 85°C (-40°F to 185°F)

Ambient Relative Humidity

- 5% to 95% (non-condensing)

Regulatory Approvals

ISO

- Manufactured in an ISO9001 facility

Safety

UL508

EMI

FCC Part 15B, Class A

EN61000-6-4

EN55022

EN61000-3-2

EN61000-3-3

EMS

EN61000-6-2

- EN61000-4-2 (ESD Standards)
- EN61000-4-3 (Radiated RFI Standards)
- EN61000-4-4 (Burst Standards)
- EN61000-4-5 (Surge Standards)
- EN61000-4-6 (Induced RFI Standards)
- EN61000-4-8 (Magnetic Field Standards)

Environmental Test Compliance

IEC60068-2-6 Fc (Vibration Resistance)

IEC60068-2-27 Ea (Shock)

FED STD 101C Method 5007.1 (Free fall w/ package)

Application Diagram

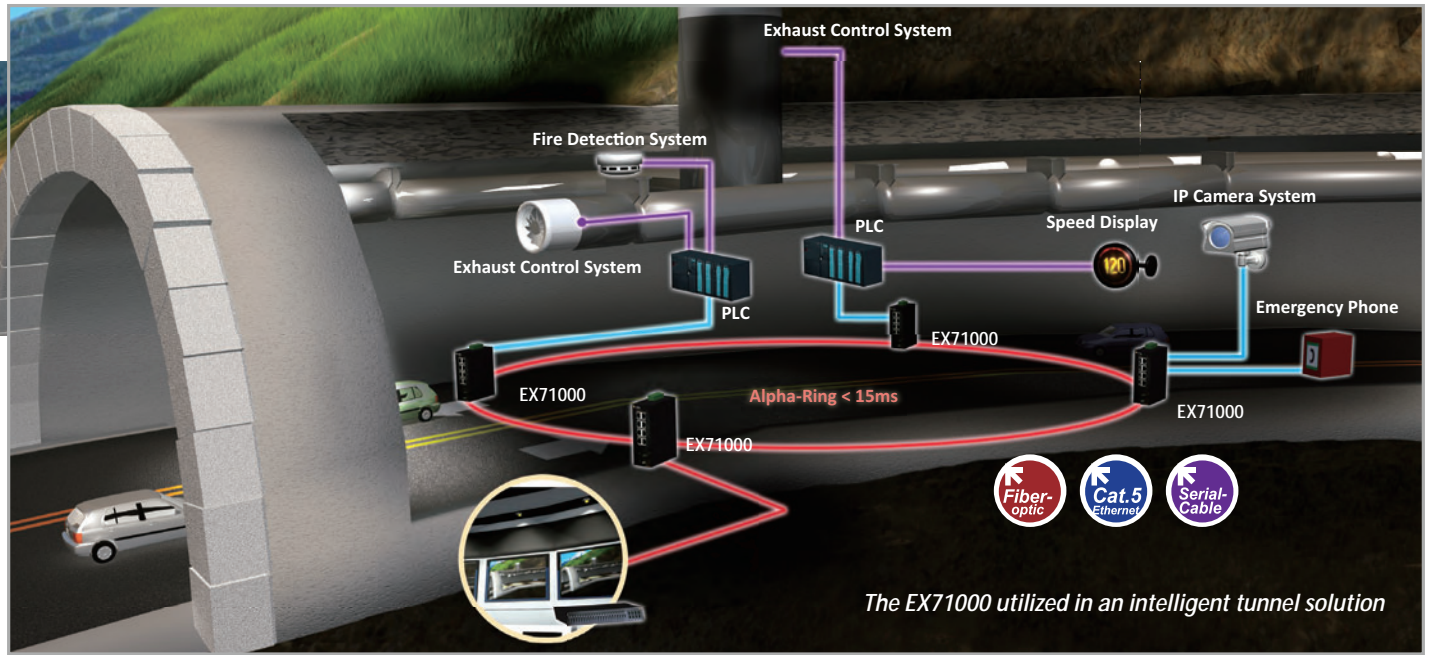

Dimensions

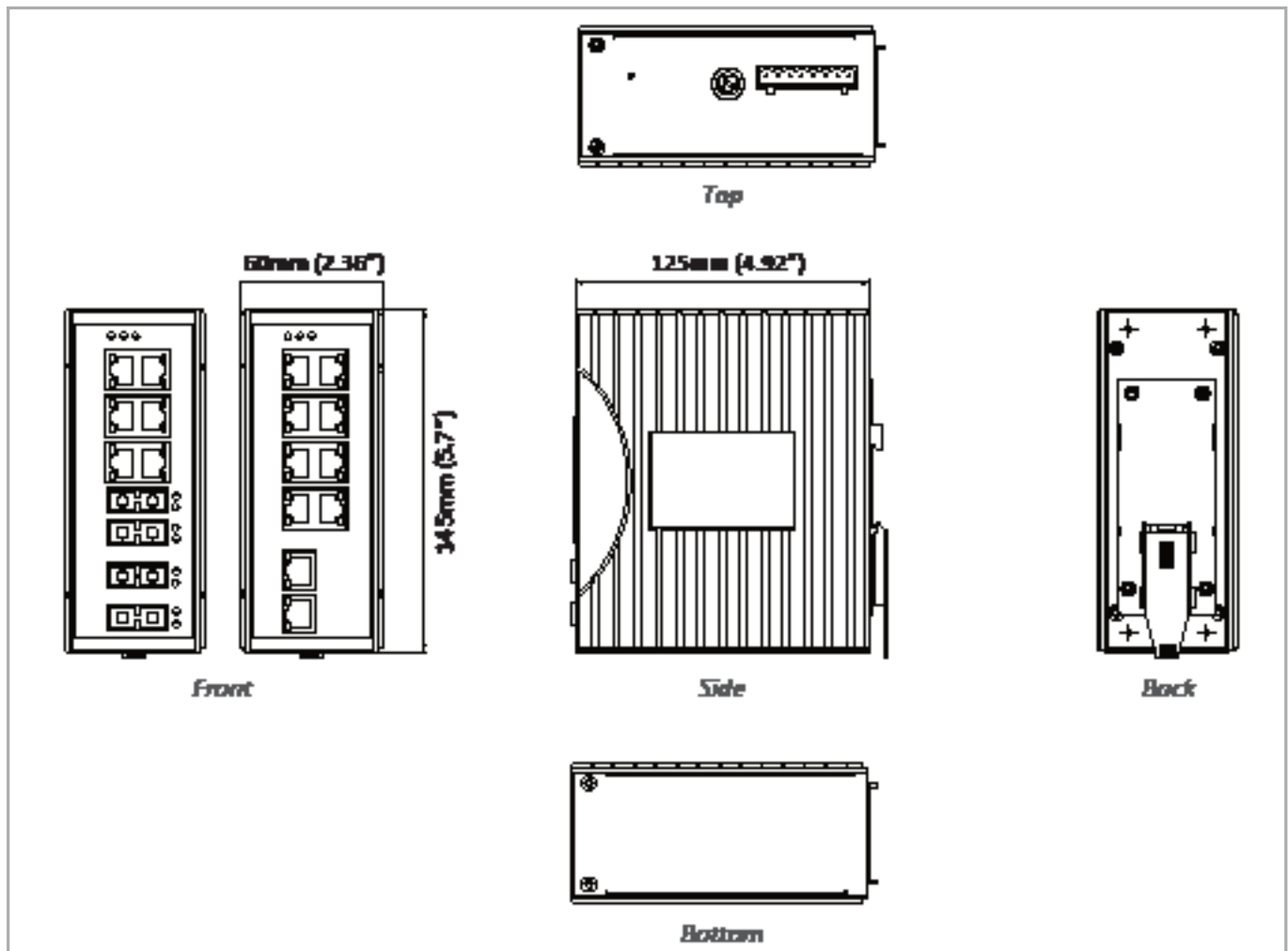

Ordering Information

Model

EX61800A-00B	8-port 10/100BASE-TX Industrial Managed Ethernet Switch
EX61801A-0YB	8-port 10/100BASE-TX + 1-port Gigabit Industrial Managed Ethernet Switch
EX61802A-0YB	8-port 10/100BASE-TX + 2-port Gigabit Industrial Managed Ethernet Switch
EX61620A-X0B	6-port 10/100BASE-TX + 2-port 100BASE-FX Industrial Managed Ethernet Switch
EX61621A-XYB	6-port 10/100BASE-TX + 2-port 100BASE-FX + 1-port Gigabit Industrial Managed Ethernet Switch
EX61622A-XYB	6-port 10/100BASE-TX + 2-port 100BASE-FX + 2-port Gigabit Industrial Managed Ethernet Switch
EX61420A-X0B	4-port 10/100BASE-TX + 2-port 100BASE-FX Industrial Managed Ethernet Switch
EX61422A-XYB	4-port 10/100BASE-TX + 2-port 100BASE-FX + 2-port Gigabit Industrial Managed Ethernet Switch
EX61440A-X0B	4-port 10/100BASE-TX + 4-port 100BASE-FX Industrial Managed Ethernet Switch

* DIN-Rail mounting kit included

100FX Fiber Options (X)

1	Multi Mode (SC) - 2Km
2	Multi Mode (ST) - 2Km
6	Multi Mode (SC) WDM-TX:1310nm/RX:1550nm - 2Km
7	Multi Mode (SC) WDM-TX:1550nm/RX:1310nm - 2Km
8	Multi Mode (SC) WDM-TX:1310nm/RX:1550nm - 5Km
9	Multi Mode (SC) WDM-TX:1550nm/RX:1310nm - 5Km
A	Single Mode (SC) - 20Km
B	Single Mode (SC) - 40Km
H	Single Mode (ST) - 20Km
P	Single Mode (SC) WDM-TX:1310nm/RX:1550nm - 20Km
Q	Single Mode (SC) WDM-TX:1550nm/RX:1310nm - 20Km
R	Single Mode (SC) WDM-TX:1310nm/RX:1550nm - 40Km
S	Single Mode (SC) WDM-TX:1550nm/RX:1310nm - 40Km
V	100BASE SFP

Gigabit Port Options (Y)

1	10/100/1000BASE-TX
3	1000BASE-SX(SC) - 550m
4	1000BASE-SX (SC) - 2Km
5	1000BASE-SX (ST) - 550m
A	1000BASE-LX (SC) - 10Km
B	1000BASE-LX (SC) - 20Km
R	1000BASE-BX (SC) WDM-TX:1310nm/RX:1550nm - 20Km
S	1000BASE-BX (SC) WDM-TX: 1550nm/RX: 1310nm - 20Km
V	1000BASE SFP

Optional Accessories

KP-AA96-480	Panel mounting Kits
KR-BK71000	Rack mounting Kits
DR-30-24	30W/1.5A DIN-Rail 24VDC Industrial Power Supply (for Terminal Block)
DR-60--24	60W/2.5A DIN-Rail 24VDC Industrial Power Supply (for Terminal Block)
DR-75-24	75W/3.2A DIN-Rail 24VDC Industrial Power Supply (for Terminal Block)
DR-120-24	120W/5A DIN-Rail 24VDC Industrial Power Supply (for Terminal Block)
41-136046-X	36W/3A 12VDC hardened power adapter with open wire in aluminum housing (for Terminal Block) (X) = 1: US, 2: EU, 3: UK, 4: AU, 5: JP, 6: SA
41-136044-X	36W/3A 12VDC hardened power adapter with latched DC Jack in aluminum housing (for DC Jack) (X) = 1: US, 2: EU, 3: UK, 4: AU, 5: JP, 6: SA

EX62000 Series

Industrial Managed 8 to 14 ports 10/100BASE and 2-port Gigabit Ethernet Switch with SFP options



Overview

EtherWAN's EX62000 Series provides an industrial Fully Managed 14-port switching platform combining high performance switching backbone with robust and secure management features required for mission critical and harsh environments where sustained connectivity is crucial.

The EX62000 Series is equipped with eight to fourteen 10/100BASE Fast Ethernet ports, or in combination with up to two Gigabit, Fixed Fiber, or SFP Combo port options. Panel mountable, the EX62000 Series is equipped with EtherWAN's Alpha-Ring self-healing technology, providing less than 15ms fault recovery time making it ideal for applications intolerant to interruption.

Users are able to access management features such as; port security, IGMP snooping, VLANs, GARP protocols, LACP, and via web browser, Telnet, SNMP, RMON, TFTP, and RS-232 console interfaces.

EtherWAN — "When Connectivity is Crucial."

Spotlight

• Versatile Connectivity

- Provides flexibility of 8-port to 14-port 10/100BASE-TX/FX/BX plus 2-port Gigabit-TX/SX/LX/BX/SFP combos

• Intelligent Data Management

- Optimize network performance with QoS, VLAN etc.

• Secure Remote Access

- IEEE802.1x and RADIUS support

Software Features

Management

- Interface
 - CLI, Telnet and web browser
 - SNMP v1/v2c/v3
- Firmware and configuration upgrade and backup via TFTP
- Supports DHCP Server/Client
- RMON (Remote monitoring): group 1, 2, 3, 9
- Port mirroring: TX/RX and both
- NTP (Network Time Protocol) time synchronization
- IEEE802.1ab LLDP (Link Layer Discovery Protocol)

Security

- MAC address filtering
- Enable/disable port
- Storm control (broadcast and multicast types)
- IEEE802.1x LAN access control
- Remote authentication through RADIUS
- SSH for CLI and Telnet security
- SSL for web security
- Multi-level user account/password against unauthorized configuration
- System log (remote/local)

Quality of Service (QoS)

- Priority Queues: 4 queues per port
- Traffic classification based on IEEE802.1p CoS, DSCP, WRR (Weighted round robin) and strict mode
- Rate Limiting (Ingress/Egress)

Layer 2 Features

- Auto-negotiation for port speed and duplex mode
- Flow Control
 - IEEE802.3x full duplex mode
 - Back-Pressure half duplex mode
- Redundant Protocols
 - IEEE802.1D Spanning Tree Protocol (STP)
 - IEEE802.1w Rapid Spanning Tree Protocol (RSTP)
 - IEEE802.1s Multiple Spanning Tree Protocol (MSTP)
 - EtherWAN's Alpha-Ring network fault recovery (<15ms)
- VLANs
 - Port-based VLANs
 - IEEE802.1Q Tag VLANs (128 groups, 4096 VID)
 - GVRP (GARP VLAN Registration Protocol)
 - GMRP (GARP Multicast Registration Protocol)
- Link Aggregation
 - Static Trunk (2 groups, support MAC base)
 - IEEE802.3ad Link Aggregation Control Protocol
- IGMP Snooping
 - IGMP snooping v1/v2/v3

Performance

- Switching Capability: 6.8Gbps
- Packet Buffer Size: 2M bits
- MAC Address Table: 8192

Hardware Specifications

Technology

Standards

- IEEE802.3 10BASE-T
- IEEE802.3u 100BASE-TX/100BASE-FX
- IEEE802.3ab 1000BASE-T
- IEEE802.3z 1000BASE-SX/1000BASE-LX
- IEEE802.3x Full duplex and flow control
- IEEE802.1p QoS
- IEEE802.1Q Tag VLANs
- IEEE802.1w RSTP
- IEEE802.1x Port-based Network Access Control

Forward and Filtering Rate

- 14,880pps for 10Mbps
- 148,810pps for 100Mbps
- 1,488,100pps for 1000Mbps

Packet Buffer Memory

- 2M bits

Processing Type

- Store-and-Forward
- Auto Negotiation
- Half-duplex back-pressure and IEEE802.3x full-duplex flow control
- Auto MDI/MDIX

Address Table Size

- 8192 MAC addresses

Power

Input

- Redundant power inputs:
 - 12 - 48VDC (Terminal Block)
 - 12VDC (DC Jack)

Power Consumption

- 15W Max. 1.25A @ 12VDC, 0.625A @ 24VDC

Protection

- Overload current protection
- Reverse polarity protection

Mechanical

Casing

- Metal Case
- IP30

Dimensions

- 235mm (W) x 125mm (D) x 50mm (H)
(9.25" (W) x 4.92" (D) x 1.97" (H))

Weight

- 1.5Kg (3.3lbs.)

Installation

- DIN-Rail (Top hat type 35mm), Panel or Rack mounting

Interface

Ethernet Port

- 10/100BASE-TX: 14, 13, 12 or 8 port
- 100BASE-FX: 0, 1 or 2 ports
- Gigabit: 0, 1 or 2 ports

Console Port

- Port: One DB9 RS-232 port

LED Indicators

- Per Unit: Power 1, Power 2, Power 3
- Per Port: Link/Activity, Speed

Environment

Operating Temperature

- -10°C to 60°C (-40°F to 167°F)
Tested @ -20°C to 70°C (-40°F to 158°F)

Storage Temperature

- -40°C to 85°C (-40°F to 185°F)

Ambient Relative Humidity

- 5% to 95% (non-condensing)

Regulatory Approvals

ISO

- Manufactured in an ISO9001 facility

EMI

FCC Part 15B, Class A

EN61000-6-4

EN55022

EN61000-3-2

EN61000-3-3

EMS

EN61000-6-2

- EN61000-4-2 (ESD Standards)
- EN61000-4-3 (Radiated RFI Standards)
- EN61000-4-4 (Burst Standards)
- EN61000-4-5 (Surge Standards)
- EN61000-4-6 (Induced RFI Standards)
- EN61000-4-8 (Magnetic Field Standards)

Environmental Test Compliance

IEC60068-2-6 Fc (Vibration Resistance)

IEC60068-2-27 Ea (Shock)

FED STD 101C Method 5007.1 (Free fall w/ package)

Application Diagram

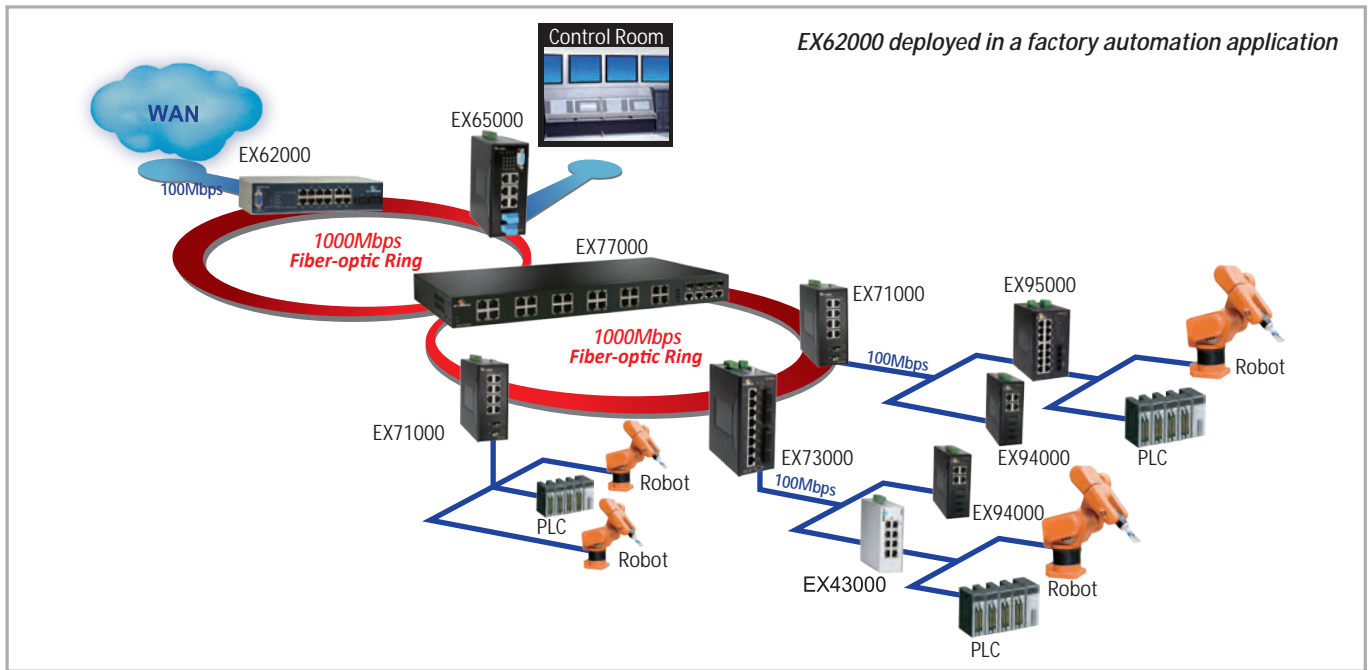

Dimensions

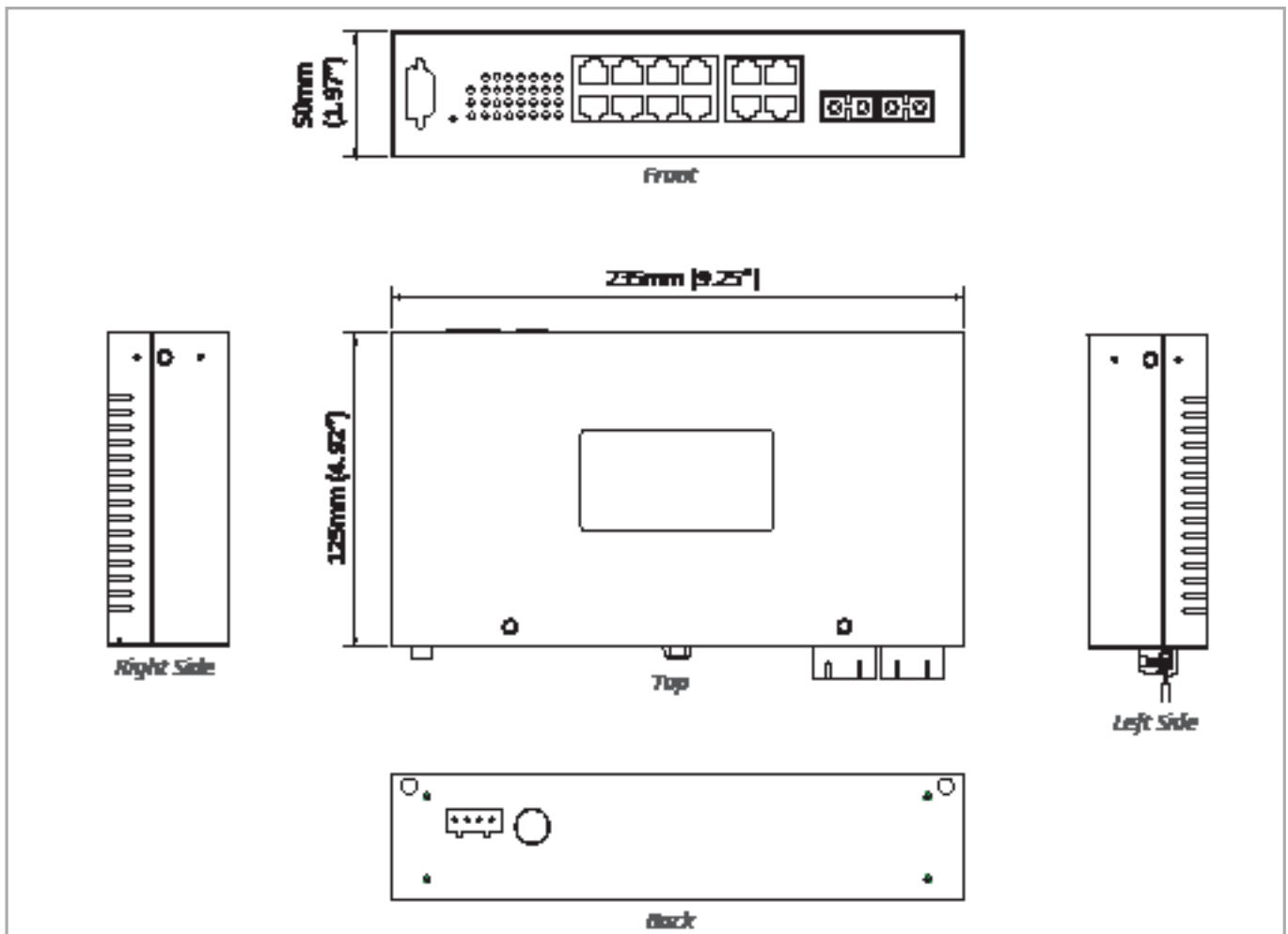

Ordering Information

Model

EX62140-00B	14-port 10/100BASE-TX Industrial Managed Ethernet Switch
EX62141-X0B	13-port 10/100BASE-TX + 1-port 100BASE-FX Industrial Managed Ethernet Switch
EX62142-X0B	12-port 10/100BASE-TX + 2-port 100BASE-FX Industrial Managed Ethernet Switch
EX62102-X0B	8-port 10/100BASE-TX + 2-port 100BASE-FX Industrial Managed Ethernet Switch
EX62128-0YB	12-port 10/100BASE-TX + 1-port Gigabit Industrial Managed Ethernet Switch
EX62129-0YB	12-port 10/100BASE-TX + 2-port Gigabit Industrial Managed Ethernet Switch
EX62088-0YB	8-port 10/100BASE-TX + 1-port Gigabit Industrial Managed Ethernet Switch
EX62089-0YB	8-port 10/100BASE-TX + 2-port Gigabit Industrial Managed Ethernet Switch

100FX Fiber Options (X)

1	Multi Mode (SC) - 2Km
2	Multi Mode (ST) - 2Km
6	Multi Mode (SC) WDM-TX:1310nm/RX:1550nm - 2Km
7	Multi Mode (SC) WDM-TX:1550nm/RX:1310nm - 2Km
8	Multi Mode (SC) WDM-TX:1310nm/RX:1550nm - 5Km
9	Multi Mode (SC) WDM-TX:1550nm/RX:1310nm - 5Km
A	Single Mode (SC) - 20Km
B	Single Mode (SC) - 40Km
H	Single Mode (ST) - 20Km
P	Single Mode (SC) WDM-TX:1310nm/RX:1550nm - 20Km
Q	Single Mode (SC) WDM-TX:1550nm/RX:1310nm - 20Km
R	Single Mode (SC) WDM-TX:1310nm/RX:1550nm - 40Km
S	Single Mode (SC) WDM-TX:1550nm/RX:1310nm - 40Km

Gigabit Port Options (Y)

1	10/100/1000BASE-TX
3	1000BASE-SX(SC) - 550m
4	1000BASE-SX (SC) - 2Km
5	1000BASE-SX (ST) - 550m
A	1000BASE-LX (SC) - 10Km
B	1000BASE-LX (SC) - 20Km
R	1000BASE-BX (SC) WDM-TX:1310nm/RX:1550nm - 20Km
S	1000BASE-BX (SC) WDM-TX: 1550nm/RX: 1310nm - 20Km
V	2-port 1000BASE SFP combo 10/100/1000BASE-TX

Optional Accessories

KD-AA96000	DIN-Rail mounting kit
KP-BK6212	Panel mounting kit
KR-BK72-400	Rack mounting kit
DR-30-24	30W/1.5A DIN-Rail 24VDC Industrial Power Supply (for Terminal Block)
DR-60--24	60W/2.5A DIN-Rail 24VDC Industrial Power Supply (for Terminal Block)
DR-75-24	75W/3.2A DIN-Rail 24VDC Industrial Power Supply (for Terminal Block)
41-136046-X	36W/3A 12VDC hardened power adapter with open wire in aluminum housing (for Terminal Block); (X) = 1: US, 2: EU, 3: UK, 4: AU, 5: JP, 6: SA
41-136044-X	36W/3A 12VDC hardened power adapter with latched DC Jack in aluminum housing (for DC Jack); (X) = 1: US, 2: EU, 3: UK, 4: AU, 5: JP, 6: SA

EX38000 Series

Industrial Web-Smart 5-port 10/100BASE PoE (4 x PoE)
Ethernet Switch



Overview

EtherWAN's EX38000 Series provides an industrial 5-port switching platform supporting IEEE802.3af+ Power over Ethernet, high performance switching with robust management features required for mission-critical and harsh environments where sustained connectivity is crucial.

The EX38000 Series is equipped with four 10/100BASE-TX PoE ports, in combination with one 100FX Fiber options. The IEEE802.3af+ PoE ports provide up to 30W/port with a total power budget of 120W, making the switch truly versatile for connecting with PoE Powered Devices (PD) with different bandwidth and power consumption requirements.

Users are able to access management features such as QoS based on 802.1p, DSCP, and IP precedence. With the hardened specifications, the EX38000 Series is designed to operate at -10°C to 60°C in harsh environments.

EtherWAN — "When Connectivity is Crucial."

Spotlight

• Industrial Grade

- Supports -10°C to 60°C (14°F to 140°F) operating temperature

• PoE Connectivity

- Port 1 to 4 supports IEEE802.3at Power over Ethernet

• Fiber Connectivity

- Up to one 100BASE-FX ports with SC and ST options

• Web-Managed Interface

- Comprehensive QoS based on 802.1p, DSCP, and IP precedence

Hardware Specifications

Technology

Standards

- IEEE802.3 10BASE-T
- IEEE802.3u 100BASE-TX/100BASE-FX
- IEEE802.3af Power over Ethernet
- IEEE802.3x Full duplex and flow control

Forward and Filtering Rate

- 14,880pps for 10Mbps
- 148,810pps for 100Mbps

Packet Buffer Memory

- 512K bits

Processing Type

- Store-and-Forward
- Auto Negotiation
- Half-duplex back-pressure and IEEE802.3x full-duplex flow control
- Auto MDI/MDIX

Address Table Size

- 1024 MAC addresses

Power

Input

- Redundant power inputs:
Terminal Block: 47 - 57VDC
DC Jack: 47 - 57VDC

Power Consumption

- Device: Max. 10W (without PoE)
- PoE power budget (depends on power input): 120W Max.

PoE Power Output

- Port 1 to 4
- IEEE802.3af+: up to 30W/port, 47 - 57VDC, 600mA Max.

Protection

- Reverse polarity protection
- Overload current protection

Mechanical

Casing

- Metal case
- IP30

Dimensions

- 200mm (W) x 134.3mm (D) x 35mm (H)
(7.87" (W) x 5.29" (D) x 1.38" (H))

Weight

- 0.8Kg (1.76lbs.)

Installation

- Desktop, Wall, or DIN-Rail mounting

Interface

Ethernet Ports

- 10/100BASE-TX: 5 or 4 ports
- 100BASE-FX: 0 or 1 ports

LED Indicators

- Per Unit: Power 1,
Power 2,
Power 3 (Green),
Fault (Red)
- Per Port: Link/Activity (Green)

Alarm Contact

- One relay output with current 1A @ 250VAC

Environment

Operating Temperature

- -10°C to 60°C (14°F to 140°F)
Tested @ -20°C to 70°C (-4°F to 158°F)

Storage Temperature

- -40°C to 85°C (-40°F to 185°F)

Ambient Relative Humidity

- 5% to 95% (non-condensing)

Regulatory Approvals

ISO

- Manufactured in an ISO9001 facility

EMI

FCC Part 15B, Class A

EN61000-6-4

EN55022 Class A

EMS

EN61000-6-2

- EN61000-4-2 (ESD Standards)
- EN61000-4-3 (Radiated FRI Standards)
- EN61000-4-4 (Burst Standards)
- EN61000-4-5 (Surge Standards)
- EN61000-4-6 (Induced RFI Standards)
- EN61000-4-8 (Magnetic Field Standards)

Environmental Test Compliance

IEC60068-2-6 Fc (Vibration)

IEC60068-2-27 Ea (Shock)

FED STD 101C Method 5007.1 (Free fall w/ package)

Industrial Compliance

NEMA TS2

Dimensions

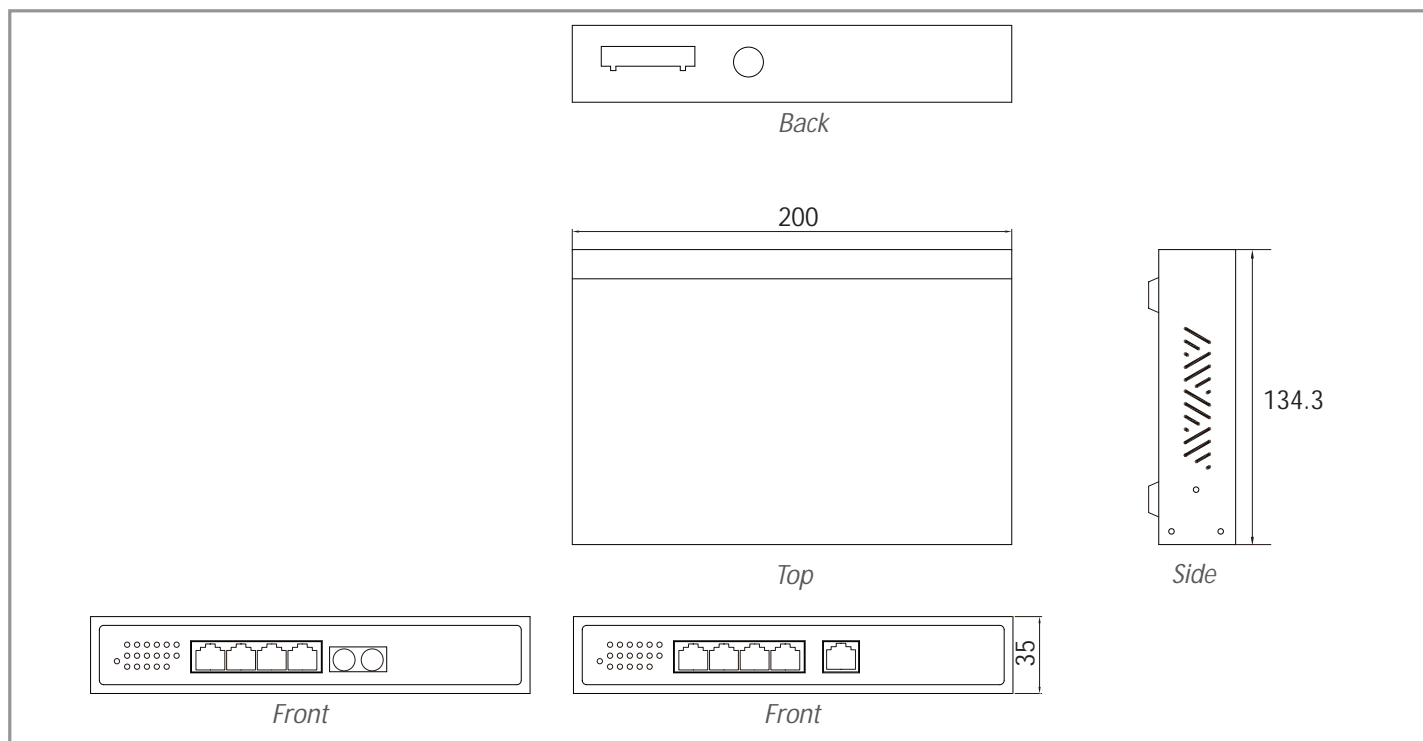

Ordering Information

Model

EX38050-00B	Industrial Web-smart 5-port 10/100BASE-TX PoE Ethernet Switch
EX38041-X0B	Industrial Web-smart 4-port 10/100BASE-TX + 1-port 100BASE-FX PoE Ethernet Switch

* DIN-Rail mounting kit included

100FX Fiber Options (X)

1	Multi Mode (SC) - 2Km
2	Multi Mode (ST) - 2Km
6	Multi Mode (SC) WDM-TX:1310nm/RX:1550nm - 2Km
7	Multi Mode (SC) WDM-TX:1550nm/RX:1310nm - 2Km
8	Multi Mode (SC) WDM-TX:1310nm/RX:1550nm - 5Km
9	Multi Mode (SC) WDM-TX:1550nm/RX:1310nm - 5Km
A	Single Mode (SC) - 20Km
B	Single Mode (SC) - 40Km
H	Single Mode (ST) - 20Km
P	Single Mode (SC) WDM-TX:1310nm/RX:1550nm - 20Km
Q	Single Mode (SC) WDM-TX:1550nm/RX:1310nm - 20Km
R	Single Mode (SC) WDM-TX:1310nm/RX:1550nm - 40Km
S	Single Mode (SC) WDM-TX:1550nm/RX:1310nm - 40Km

*More 100FX Fiber options also available upon request.

Optional Accessories

KD-AA78000X	DIN-Rail Mounting Kit
SDR-240-48	240W/5A DIN-Rail 48VDC Industrial Power Supply
SDR-480-48	480W/10A DIN-Rail 48VDC Industrial Power Supply

EX39924 Series

Industrial Unmanaged 24-port Gigabit Switch with 4/16-port
combo SFP Slots



Overview

EtherWAN's EX39924 Series is an industrial Unmanaged Gigabit switching platform, designed for easy deployment in harsh environments.

The EX39924 Series is equipped with twenty-four Gigabit Ethernet ports, or a combination of Gigabit copper ports and four or sixteen combo SFP Gigabit ports for long distance connectivity. Although unmanaged, the EX39924 is feature rich with 16379 bytes jumbo frame support, full wire speed Gigabit throughput, QoS support and eco-friendly IEEE802.3az EEE (Energy Efficient Ethernet) compliant, making the EX39924 Series a powerful yet energy efficient network switch.

EtherWAN – "When Connectivity is Crucial."

Spotlight

- **Industrial Grade**
 - Supports -10°C to 60°C (14°F to 140°F) operating temperature
- **Jumbo Frame Support**
 - Up to 16379 bytes
- **Fiber Connectivity**
 - Up to 4 or 16 combo 1000BASE SFP ports
- **High Reliability**
 - Fanless Design
 - No moving parts
- **Full Wire Speed**
 - Non Blocking
 - Full Duplex Simultaneous Communication on all ports
- **Rack Mount**
 - Enterprise level 1U Rackmount

Hardware Specifications

Technology

Standards

- IEEE802.3 10BASE-T
- IEEE802.3u 100BASE-TX
- IEEE802.3ab 1000BASE-T
- IEEE802.3z 1000BASE-SX/1000BASE-LX
- IEEE802.3x Full duplex and flow control
- IEEE802.1az Energy Efficient Ethernet
- IEEE802.1p Quality of Service (QoS)

Forward and Filtering Rate

- 14,880pps for 10Mbps
- 148,810pps for 100Mbps
- 1,488,100pps for 1000Mbps

Packet Buffer Memory

- 512 KB

Processing Type

- Store-and-Forward
- Auto Negotiation
- Half-duplex back-pressure and IEEE802.3x full-duplex flow control
- Auto MDI/MDIX

Jumbo Frame

- 16379 bytes

Address Table Size

- 8192 MAC addresses

Power

Input

- 100 - 240VAC, 50 - 60Hz Internal Universal PSU

Mechanical

Casing

- Metal
- IP30

Dimensions

- 440mm (W) x 210mm (D) x 44mm (H)
(17.32" (W) x 8.19" (D) x 1.73" (H))

Weight

- 2.9Kg (6.4lbs.)

Installation

- Rack mounting

Interface

Ethernet Ports

- Gigabit: 24 ports
- Combo SFP: 16 or 4 ports

LED Indicators

- Per Unit: Power (Green)
- Per Port: 10/100M (Green)
1000M (Green)

Environment

Operating Temperature

- -10°C to 60°C (14°F to 140°F)
Tested@-20°C to 70°C (-4°F to 158°C)

Storage Temperature

- -40°C to 85°C (-40°F to 185°F)

Ambient Relative Humidity

- 5% to 95% (non-condensing)

Regulatory Approvals

ISO

- Manufactured in an ISO9001 facility

EMI

FCC Part 15B, Class A

VCCI Class A

EN61000-6-4

EN55022 Class A

EN61000-3-2

EN61000-3-3

EMS

EN61000-6-2

- EN61000-4-2 (ESD Standards)
- EN61000-4-3 (Radiated RFI Standards)
- EN61000-4-4 (Burst Standards)
- EN61000-4-5 (Surge Standards)
- EN61000-4-6 (Induced RFI Standards)
- EN61000-4-8 (Magnetic Field Standards)
- EN61000-4-11 (Voltage Dips & Voltage Variations)

Environmental Test Compliances

IEC60068-2-6 Fc (Vibration)

IEC60068-2-27 Ea (Shock)

IEC60068-2-32 Ed (Free fall)

Dimensions

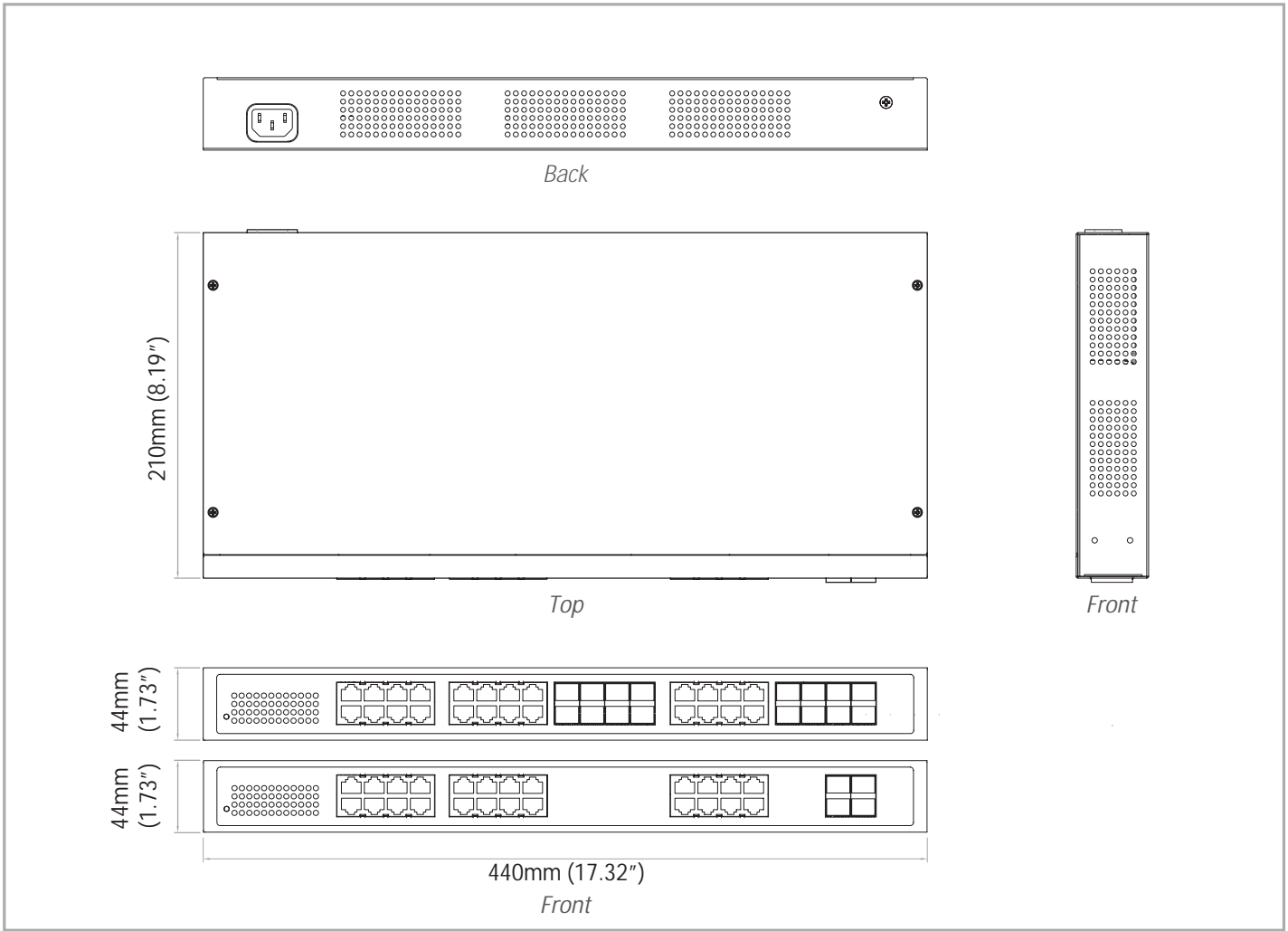

Ordering Information

Model

EX39924-16	Industrial Unmanaged 24-port 10/100/1000BASE-T (16-port combo SFP) Ethernet Switch
EX39924-4	Industrial Unmanaged 24-port 10/100/1000BASE-T (4-port combo SFP) Ethernet Switch

EX32900 Series

Industrial Unmanaged 5/8-port 10/100/1000BASE Gigabit Ethernet Switch



Overview

EtherWAN's EX32900 Series is a compact industrial Unmanaged Gigabit switching platform, designed for easy deployment in harsh environments.

The EX32900 Series is equipped with five or eight Gigabit Ethernet ports, or a combination of Gigabit copper ports and one Gigabit fiber port for long distance connectivity. Although unmanaged, the EX32900 is feature-rich with Jumbo Frame support, full wire speed Gigabit throughput, QoS support and eco-friendly IEEE802.3az EEE (Energy Efficient Ethernet) compliant, making the EX32900 Series a powerful yet energy efficient network switch.

EtherWAN—"When Connectivity is Crucial."

Spotlight

- **Industrial Grade**
 - Supports -10°C to 60°C (14°F to 140°F) operating temperature
 - Supports DIN-Rail mounting
- **Jumbo Frame Support**
 - Up to 10K bytes (EX32905/EX32914 Series)
 - Up to 9720 bytes (EX32908/EX32917 Series)
- **Fiber Connectivity**
 - Up to one 1000BASE-SX port with SC and ST options
- **High Reliability**
 - Fanless Design
 - No moving parts

Hardware Specifications

Technology

Standards

- IEEE802.3 10BASE-T
- IEEE802.3u 100BASE-TX/100BASE-FX
- IEEE802.3ab 1000BASE-T
- IEEE802.3z 1000BASE-SX/1000BASE-LX
- IEEE802.1x, Full duplex flow control
- IEEE802.1az Energy Efficient Ethernet
- IEEE802.1p Quality of Service (QoS)

Forward and Filtering Rate

- 14,880pps for 10Mbps
- 148,810pps for 100Mbps
- 1,488,100pps for 1000Mbps

Packet Buffer Memory

- EX31905/EX32914: 1M bits
- EX32908/EX32917: 192KB

Processing Type

- Store-and-Forward
- Auto Negotiation
- Half-duplex back-pressure and IEEE802.3x full-duplex flow control
- Auto MDI/MDIX

Jumbo Frame

- EX32905/EX32914: 10K bytes
- EX32908/EX32917: 9720 bytes

Address Table Size

- EX32905/EX32914: 8K MAC addresses
- EX32908/EX32917: 4K MAC addresses

Power

Input Voltage

- 12 to 48VDC

Power Consumption

- 6.5W Max. 0.25A @ 24VDC

Protection

- Reverse polarity protection
- Overload current protection

Mechanical

Casing

- Plastic case
- IP30

Dimensions

- EX32905/EX32914:
26mm (W) x 76.5mm (D) x 114mm (H)
(1.02" (W) x 3.06" (D) x 4.33" (H))
- EX32908/EX32917:
35mm (W) x 86mm (D) x 149mm (H)
(1.4" (W) x 3.44" (D) x 5.96" (H))

Weight

- EX32905/EX32914: 0.2Kg (0.44lb.)
- EX32908/EX32917: 0.3Kg (0.66lb.)

Installation

- DIN-Rail (Top hat type 35mm)

Interface

Ethernet Ports

- EX32905/EX32914:
10/100/1000BASE-T: 5 or 4 ports
1000BASE-X: 0 or 1 ports
- EX32908/EX32917:
10/100/1000BASE-T: 8 or 7 ports
1000BASE-X: 0 or 1 ports

LED Indicators

- EX32905/EX32914:
Per Unit: Power (Green)
Per Port: 10/100M(Green),
1000M (Yellow)
- EX32908/EX32917:
Per Unit: Power 1 (Green),
Power 2 (Green),
Alarm (Red)
Per Port: 10/100M(Green),
1000M (Yellow)

Alarm Contact (EX32908/EX32917 only)

- One relay output with current 1A@250VAC
- Supports normal close and normal open

Environment

Operating Temperature

- -10°C to 60°C (14°F to 140°F)
Tested @ -20°C to 70°C (-4°F to 158°F)

Storage Temperature

- -40°C to 85°C (-40°F to 185°F)

Ambient Relative Humidity

- 5% to 95% (non-condensing)

Regulatory Approvals

ISO

- Manufactured in an ISO9001 facility

Safety

UL60950 (EX32905/EX32914 Series only)

EMI

FCC Part 15B, Class A

VCCI Class A

EN61000-6-4

EN55022 Class A

EMS

EN61000-6-2

- EN61000-4-2 (ESD Standards)
- EN61000-4-3 (Radiated RFI Standards)
- EN61000-4-4 (Burst Standards)
- EN61000-4-5 (Surge Standards)
- EN61000-4-6 (Induced RFI Standards)
- EN61000-4-8 (Magnetic Field Standards)

Environmental Test Compliances

IEC60068-2-6 Fc (Vibration)

IEC60068-2-27 Ea (Shock)

FED STD 101C Method 5007.1 (Free fall w/ package)

Dimensions

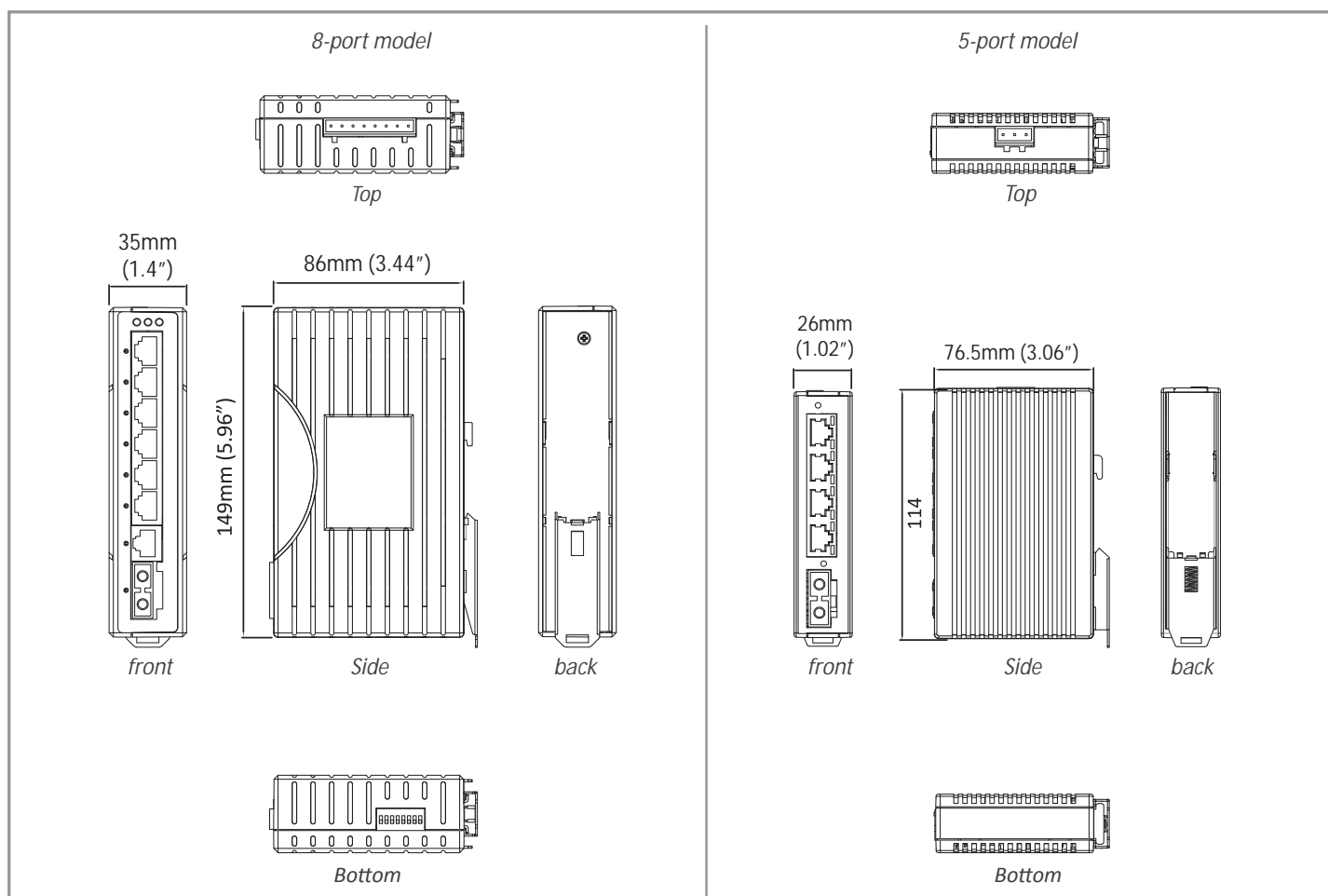

Ordering Information

Model

EX32905	Industrial Unmanaged 5-port 10/100/1000BASE-T Gigabit Ethernet Switch
EX32914-X	Industrial Unmanaged 4-port 10/100/1000BASE-T+ 1-port 1000BASE-X Gigabit Ethernet Switch
EX32908	Industrial Unmanaged 8-port 10/100/1000BASE-T Gigabit Ethernet Switch
EX32917-X	Industrial Unmanaged 7-port 10/100/1000BASE-T+ 1-port 1000BASE-X Gigabit Ethernet Switch

* DIN-Rail mounting kit included

Optical Port Options (X)

3	1000BASE-SX(SC)-550m
5	1000BASE-SX(ST)-550m
A	1000BASE-LX(SC)-10km
R	1000BASE-BX(SC) WDM-TX:1310nm/RX:1550nm-20Km
S	1000BASE-BX(SC) WDM-TX:1550nm/RX:1310nm-20Km

Optional Accessories

DR-30-24	30W/1.5A DIN-Rail 24VDC Industrial Power Supply (for Terminal Block)
DR-60-24	60W/2.5A DIN-Rail 24VDC Industrial Power Supply (for Terminal Block)
DR-75-24	75W/3.2A DIN-Rail 24VDC Industrial Power Supply (for Terminal Block)
DR-120-24	120W/5A DIN-Rail 24VDC Industrial Power Supply (for Terminal Block)
41-136046-X	36W/3A 12VDC hardened power adapter with open wire in aluminum housing (for Terminal Block) (X) = 1: US, 2: EU, 3: UK, 4: AU, 5: JP, 6: SA

EX35000 Series

Industrial Unmanaged 8-port Gigabit Ethernet Switch



Overview

EtherWAN's EX35000 Series is an industrial unmanaged Gigabit switching platform, designed for easy deployment in harsh environments.

The EX35000 Series is equipped with eight Gigabit Ethernet ports, or a combination of Gigabit copper ports and two Gigabit fiber ports for long distance connectivity. Although unmanaged, the EX35000 is feature-rich with full wire speed Gigabit throughput, making the EX35000 Series a powerful network switch.

EtherWAN – "When Connectivity is Crucial."

Spotlight

• Industrial Grade

- Supports -20°C to 60°C (-4°F to 140°F) operating temperature

• Versatile mounting Options

- DIN-Rail or panel mounting

• Fiber Connectivity

- Up to two 1000BASE ports with SC, ST and SFP options

Hardware Specifications

Technology

Standards

- IEEE802.3 10BASE-T
- IEEE802.3u 100BASE-TX/100BASE-FX
- IEEE802.3ab 100BASE-T
- IEEE802.3az 1000VASE-SX/LX
- IEEE802.3x Full duplex and flow control

Forward and Filtering Rate

- 14,880pps for 10Mbps
- 148,810pps for 100Mbps
- 1,488,100pps for 1000Mbps

Packet Buffer Memory

- 1.125M bits

Processing Type

- Store-and-Forward
- Auto Negotiation
- Half-duplex back-pressure and IEEE802.3x full-duplex flow control
- Auto MDI/MDIX

Address Table Size

- 8192 MAC addresses

Jumbo Frame

- 9K

Power

Input

- Redundant power inputs:
9 to 32VDC (Terminal Block);
12VDC (DC Jack)

Power Consumption

- 6.7W Max. 0.52A @ 12VDC, 0.26A @ 24VDC

Protection

- Reverse polarity protection
- Overload current protection

Mechanical

Casing

- Aluminum Case
- IP30

Dimensions

- 68mm (W) x 110mm (D) x 135mm (H)
(2.68" (W) x 4.33" (D) x 5.31" (H))

Weight

- 0.8Kg (1.76lbs.)

Installation

- DIN-Rail (Top hat type 35mm) or Panel mounting

Interface

Ethernet Ports

- Gigabit: 8 ports (2 Fiber combo ports included)

LED Indicators

- Per Unit: Power 1 (Green)
Power 2 (Green)
Power 3 (Green)
10/100M (Green)
1000M (Orange)

Alarm Contact

- One relay output with current 1A @ 24VDC

Environment

Operating Temperature

- -20°C to 60°C (-4°F to 140°F)
Tested @ -30°C to 70°C (-22°F to 158°F)

Storage Temperature

- -40°C to 85°C (-40°F to 185°F)

Ambient Relative Humidity

- 5% to 95% (non-condensing)

Regulatory Approvals

ISO

- Manufactured in an ISO9001 facility

Safety

UL508

EMI

FCC Part 15B Class A, VCCI Class A

EN61000-6-4

EN55022 Class A

EMS

EN61000-6-2

- EN61000-4-2 (ESD Standards)
- EN61000-4-3 (Radiated FRI Standards)
- EN61000-4-4 (Burst Standards)
- EN61000-4-5 (Surge Standards)
- EN61000-4-6 (Induced RFI Standards)
- EN61000-4-8 (Magnetic Field Standards)

Environmental Test Compliances

IEC60068-2-6 Fc (Vibration)

IEC60068-2-27 Ea (Shock)

FED STD 101C Method 5007.1 (Free fall w/ package)

Dimensions

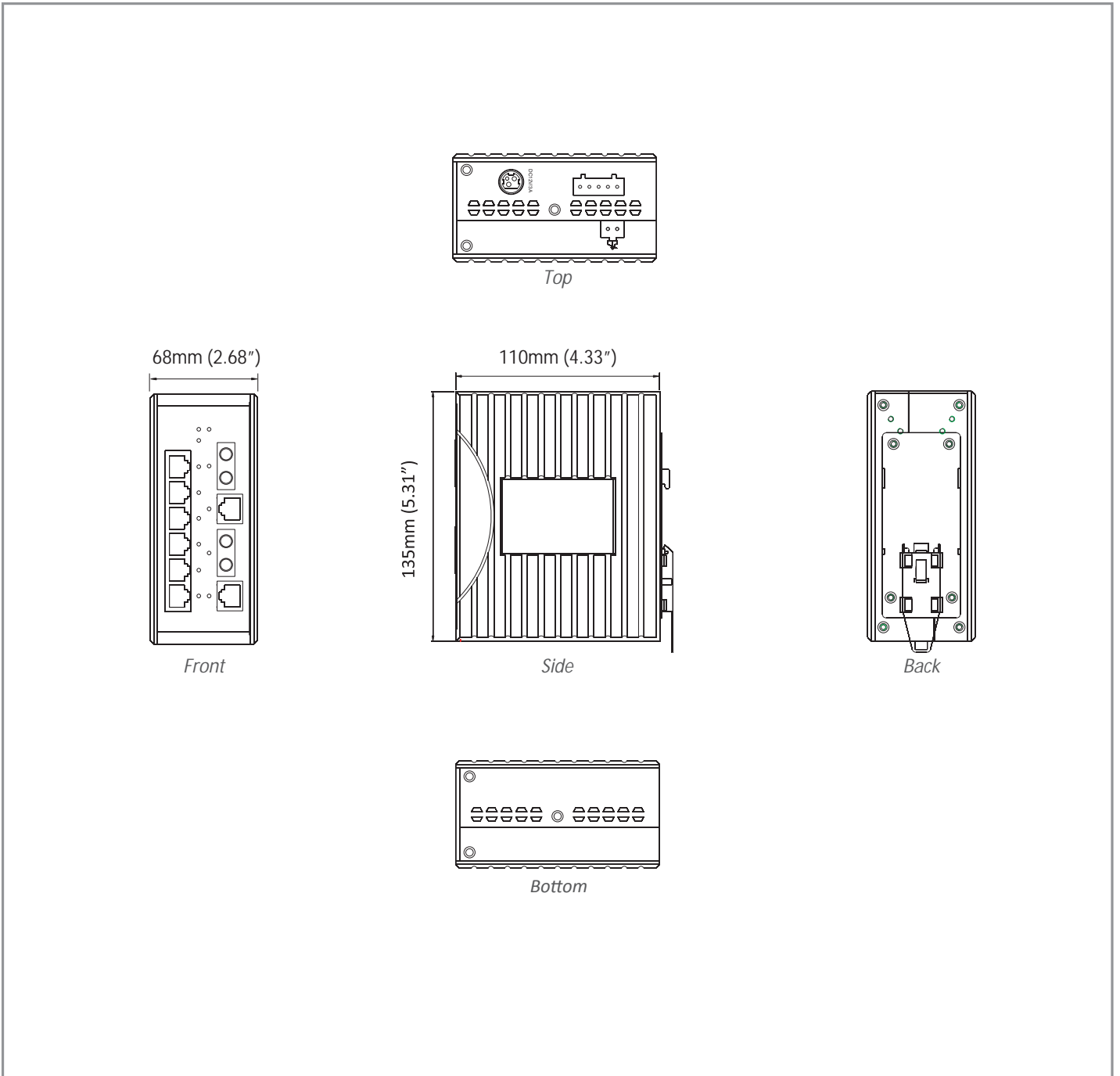

Ordering Information

Model

EX35080-00B (EOL)	Industrial Unmanaged 8-port 10/100/1000BASE-TX Ethernet Switch
EX35081-0YB (EOL)	Industrial Unmanaged 7-port 10/100/1000BASE-TX + 1-port combo Gigabit Ethernet Switch
EX35082-0YB	Industrial Unmanaged 6-port 10/100/1000BASE-TX + 2-port combo Gigabit Ethernet Switch

* DIN-Rail mounting kit included

Gigabit Port Options (Y)

1	10/100/1000BASE-TX
3	1000BASE-SX(SC) - 550m
4	1000BASE-SX (SC) - 2Km
A	1000BASE-LX (SC) - 10Km
B	1000BASE-LX (SC) - 20Km
R	1000BASE-BX (SC) WDM-TX:1310nm/RX:1550nm - 20Km
S	1000BASE-BX (SC) WDM-TX:1550nm/RX: 1310nm - 20Km
V	1000BASE SFP

*More 100FX Fiber options also available upon request.

Optional Accessories

KP-AA96-480	Panel Mounting Kit
DR-30-24	30W/1.5A DIN-Rail 24VDC Industrial Power Supply (for Terminal Block)
DR-60-24	60W/2.5A DIN-Rail 24VDC Industrial Power Supply (for Terminal Block)
DR-75-24	75W/3.2A DIN-Rail 24VDC Industrial Power Supply (for Terminal Block)
DR-120-24	120W/5A DIN-Rail 24VDC Industrial Power Supply (for Terminal Block)
41-136046-X	36W/3A 12VDC hardened power adapter with open wire in aluminum housing (for Terminal Block) (X) = 1: US, 2: EU, 3: UK, 4: AU, 5: JP, 6: SA
41-136044-X	36W/3A 12VDC hardened power adapter with latched DC Jack in aluminum housing (for DC Jack) (X) = 1: US, 2: EU, 3: UK, 4: AU, 5: JP, 6: SA

EX33000 Series

Industrial Unmanaged 16-port 10/100BASE Ethernet Switch



Overview

EtherWAN's EX33000 Series is an industrial unmanaged Fast Ethernet switching platform, designed for easy deployment in harsh environments.

The EX33000 Series is equipped with sixteen Fast Ethernet ports, or a combination of Fast Ethernet copper ports and two 100FX ports for long distance connectivity. Although unmanaged, the EX33000 is feature rich with full wire speed Fast Ethernet throughput, making the EX33000 Series a powerful network switch.

EtherWAN – "When Connectivity is Crucial."

Spotlight

- **Industrial Grade**
 - Supports -10°C to 60°C (14°F to 140°F) operating temperature
- **Versatile mounting Options**
 - Supports DIN-Rail, panel and rack mounting
- **Fiber Connectivity**
 - Up to two 100BASE-FX ports with SC, ST and WDM options

Hardware Specifications

Technology

Standards

- IEEE802.3, 10BASE-T
- IEEE802.3u 100BASE-TX/100BASE-FX
- IEEE802.3x Full duplex and flow control

Forward and Filtering Rate

- 14,880pps for 10Mbps
- 148,810pps for 100Mbps

Packet Buffer Memory

- 1.625M bits

Processing Type

- Store-and-Forward
- Auto Negotiation
- Half-duplex back-pressure and IEEE802.3x full-duplex flow control
- Auto MDI/MDIX

Address Table Size

- 4096 MAC addresses

Latency

- Less than 10 μ s

Power

Input

- Redundant power inputs:
 - 12 to 48VDC (Terminal Block),
 - 12VDC (DC Jack)

Power Consumption

- 7.4W Max. 0.6A @ 12VDC,
- 0.3A @ 24VDC,
- 0.15A @48VDC

Protection

- Overload current protection

Mechanical

Casing

- Aluminum Case
- IP30

Dimensions

- 69mm (W) x 110mm (D) x 135mm (H)
(2.72" (W) x 4.33" (D) x 5.31" (H))

Weight

- 0.87Kg (1.92lbs.)

Installation

- DIN-Rail (Top hat type 35mm), Panel, or Rack mounting

Interface

Ethernet Ports

- 10/100BASE-TX: 16, 15 or 14 ports
- 100BASE-FX: 0, 1 or 2 ports

LED Indicators

- Per Unit: Power 1 (Green),
Power 2 (Green),
Power 3 (Green)
- Per Port: Link/Act

Alarm Contact

- One relay output with current 1A @ 24VDC

Environment

Operating Temperature

- -10°C to 60°C (14°F to 140°F)
Tested @ -20°C to 70°C (-4°F to 158°F)

Storage Temperature

- -40°C to 85°C (-40°F to 185°F)

Ambient Relative Humidity

- 5% to 95% (non-condensing)

Regulatory Approvals

ISO

- Manufactured in an ISO9001 facility

EMI

FCC Part 15B, Class A

VCCI Class A

EN61000-6-4

EN55022

EN61000-3-2

EN61000-3-3

Safety

UL508

EMS

EN61000-6-2

- EN61000-4-2 (ESD Standards)
- EN61000-4-3 (Radiated RFI Standards)
- EN61000-4-4 (Burst Standards)
- EN61000-4-5 (Surge Standards)
- EN61000-4-6 (Induced RFI Standards)
- EN61000-4-8 (Magnetic Field Standards)

Environmental Test Compliances

IEC60068-2-6 Fc (Vibration)

IEC60068-2-27 Ea (Shock)

FED STD 101C Method 5007.1 (Free fall w/ package)

Dimensions

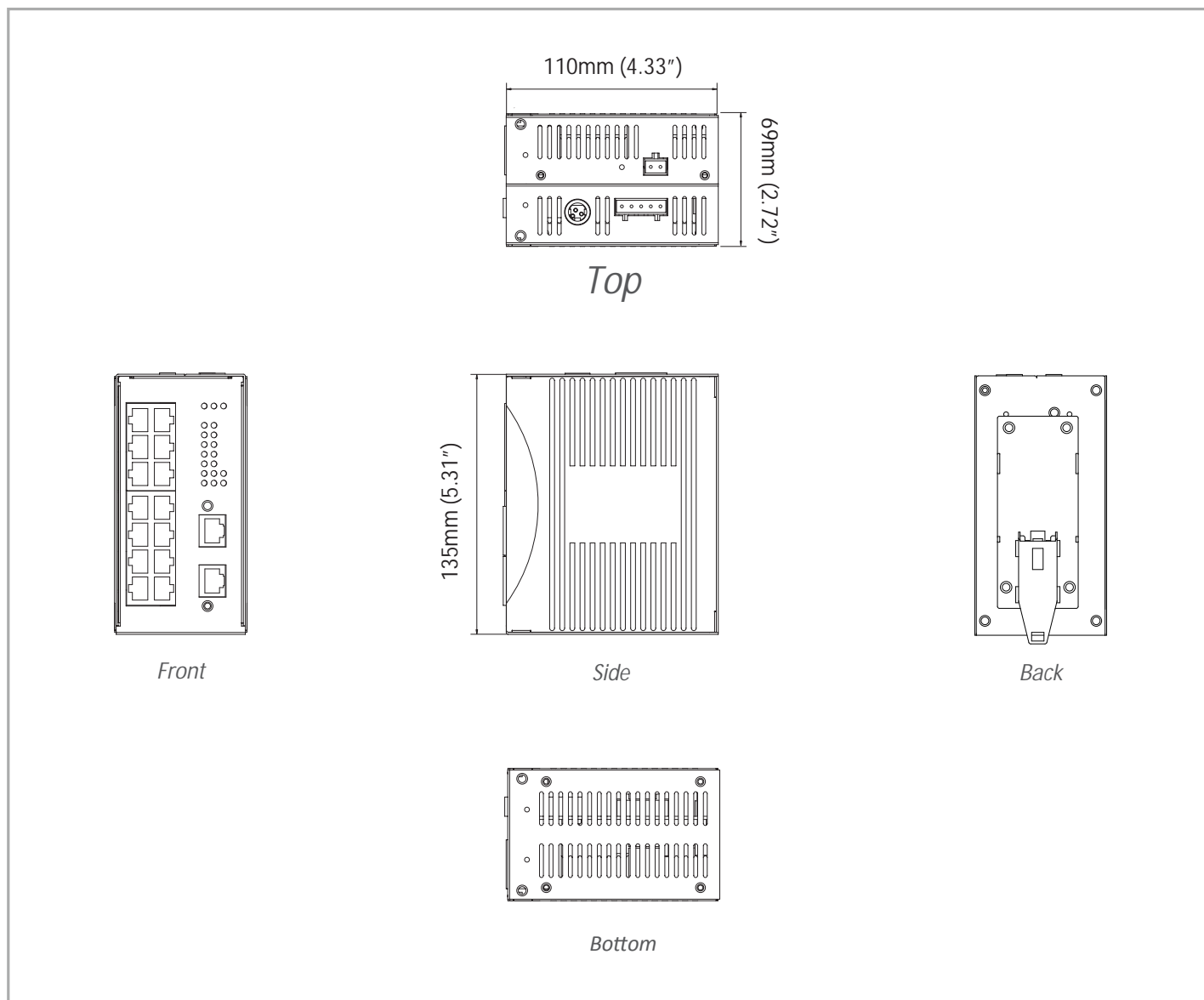

Ordering Information

Model

EX33160-00B	16-port 10/100BASE-TX Industrial Unmanaged Ethernet Switch
EX33151-X0B	15-port 10/100BASE-TX + 1-port 100BASE-FX Industrial Unmanaged Ethernet Switch
EX33142-X0B	14-port 10/100BASE-TX + 2-port 100BASE-FX Industrial Unmanaged Ethernet Switch

* DIN-Rail mounting kit included

Ordering Information - continued

100FX Fiber Options (X)

1	Multi Mode (SC) - 2Km
2	Multi Mode (ST) - 2Km
6	Multi Mode (SC) WDM-TX:1310nm/RX:1550nm - 2Km
7	Multi Mode (SC) WDM-TX:1550nm/RX:1310nm - 2Km
8	Multi Mode (SC) WDM-TX:1310nm/RX:1550nm - 5Km
9	Multi Mode (SC) WDM-TX:1550nm/RX:1310nm - 5Km
A	Single Mode (SC) - 20Km
B	Single Mode (SC) - 40Km
H	Single Mode (ST) - 20Km
P	Single Mode (SC) WDM-TX:1310nm/RX:1550nm - 20Km
Q	Single Mode (SC) WDM-TX:1550nm/RX:1310nm - 20Km
R	Single Mode (SC) WDM-TX:1310nm/RX:1550nm - 40Km
S	Single Mode (SC) WDM-TX:1550nm/RX:1310nm - 40Km

Optional Accessories

KP-AA96-480	Panel Mounting Kit
KR-BK-43-400	Rack Mounting Kit
DR-30-24	30W/1.5A DIN-Rail 24VDC Industrial Power Supply (for Terminal Block)
DR-60-24	60W/2.5A DIN-Rail 24VDC Industrial Power Supply (for Terminal Block)
DR-75-24	75W/3.2A DIN-Rail 24VDC Industrial Power Supply (for Terminal Block)
DR-120-24	120W/5A DIN-Rail 24VDC Industrial Power Supply (for Terminal Block)
41-136046-X	36W/3A 12VDC Hardened Power Adapter with Open Wire in Aluminum Housing (for Terminal Block) (X) = 1: US, 2: EU, 3: UK, 4: AU, 5: JP, 6: SA
41-136044-X	36W/3A 12VDC Hardened Power Adapter with Latched DC Jack in Aluminum Housing (X) = 1: US, 2: EU, 3: UK, 4: AU, 5: JP, 6: SA

EX34000 Series

Industrial Unmanaged 8-port 10/100BASE PoE (4 x PoE)
Ethernet Switch



Overview

EtherWAN's EX34000 Series provides an industrial 8-port switching platform supporting IEEE802.3af Power over Ethernet, high performance switching with robust features required for mission-critical and harsh environments where sustained connectivity is crucial.

The EX34000 Series is equipped with 4 10/100BASE-TX PoE ports, in combination with two 100FX Fiber options.

The IEEE802.3af PoE ports provide up to 15.4W/port with a total power budget of 61.6W, making the switch truly versatile for connecting with PoE Powered Devices (PD) with different bandwidth and power consumption requirements.

EtherWAN—"When Connectivity is Crucial."

Spotlight

- **Industrial Grade**
 - Supports -10°C to 60°C (14°F to 140°F) operating temperature
- **PoE Connectivity**
 - Port 1 to 4 supports IEEE802.3af Power over Ethernet
- **Fiber Connectivity**
 - Up to two 100BASE-FX ports with SC and ST options

Hardware Specifications

Technology

Standards

- IEEE802.3 10BASE-T
- IEEE802.3u 100BASE-TX/100BASE-FX
- IEEE802.3af Power over Ethernet
- IEEE802.3x Full duplex and flow control

Forward and Filtering Rate

- 14,880pps for 10Mbps
- 148,810pps for 100Mbps

Packet Buffer Memory

- 1M bits

Processing Type

- Store-and-Forward
- Auto Negotiation
- Half-duplex back-pressure and IEEE802.3x full-duplex flow control
- Auto MDI/MDIX

Address Table Size

- 1024 MAC addresses

Power

Input

- Redundant power inputs:
Terminal Block: 47 - 55VDC
DC Jack: 47 - 55VDC

Power Consumption

- Device: Max. 10W (without PoE)
- PoE power budget (depends on power input): 61.6W Max.

PoE Power Output

- Port 1 to 4
- IEEE802.3af: up to 15.4W/port, 47 - 55VDC, 350mA Max.

Protection

- Reverse polarity protection
- Overload current protection

Mechanical

Casing

- Aluminum case
- IP30

Dimensions

- 62mm (W) x 110mm (D) x 135mm (H)
(2.44" (W) x 4.33" (D) x 5.31" (H))

Weight

- 1Kg (2.2lbs.)

Installation

- DIN-Rail (Top hat type 35mm), Panel, or Rack mounting

Interface

Ethernet Ports

- 10/100BASE-TX: 8, 7 or 6 ports
- 100BASE-FX: 0, 1 or 2 ports

LED Indicators

- Per Unit: Power 1 (Green),
Power 2 (Green),
Power 3 (Green)
- Per Port: Link/Activity (Green)

Alarm Contact

- One relay output with current 1A @ 24VDC

Environment

Operating Temperature

- -10°C to 60°C (14°F to 140°F)
Tested @ -20°C to 70°C (-4°F to 158°F)

Storage Temperature

- -40°C to 85°C (-40°F to 185°F)

Ambient Relative Humidity

- 5% to 95% (non-condensing)

Regulatory Approvals

ISO

- Manufactured in an ISO9001 facility

EMI

FCC Part 15B, Class A

VCCI, Class A

EN61000-6-4

EN55022 Class A

EMS

EN61000-6-2

- EN61000-4-2 (ESD Standards)
- EN61000-4-3 (Radiated RFI Standards)
- EN61000-4-4 (Burst Standards)
- EN61000-4-5 (Surge Standards)
- EN61000-4-6 (Induced RFI Standards)
- EN61000-4-8 (Magnetic Field Standards)

Environmental Test Compliances

IEC60068-2-6 Fc (Vibration)

IEC60068-2-27 Ea (Shock)

FED STD 101C Method 5007.1 (Free fall w/ package)

Dimensions

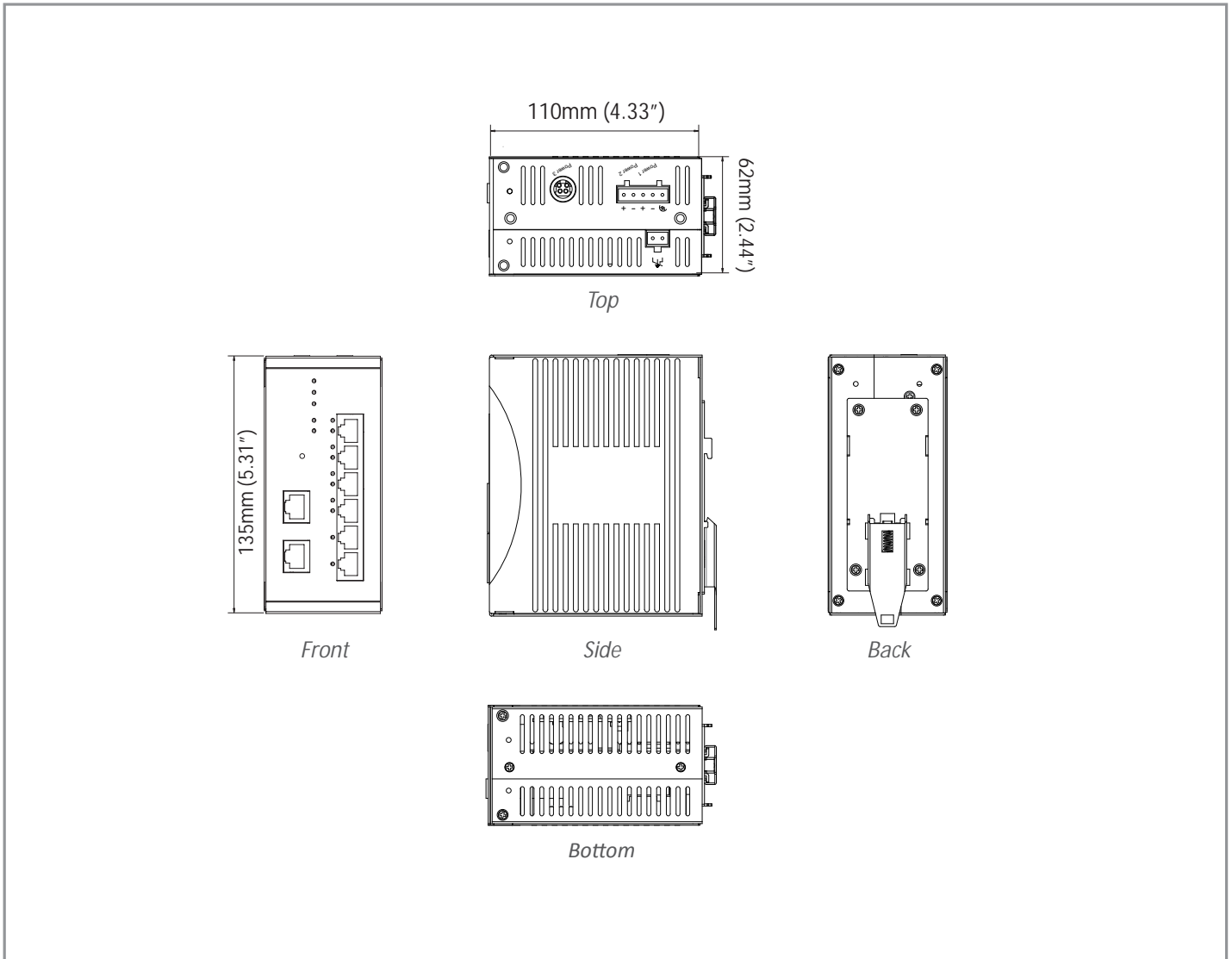

Ordering Information

Model

EX34080-00B	Industrial Unmanaged 8-port 10/100BASE-TX PoE Ethernet Switch
EX34071-X0B	Industrial Unmanaged 7-port 10/100BASE-TX + 1-port 100BASE-FX PoE Ethernet Switch
EX34062-X0B	Industrial Unmanaged 6-port 10/100BASE-TX + 2-port 100BASE-FX PoE Ethernet Switch

* DIN-Rail mounting kit included

Ordering Information - continued

100FX Fiber Options (X)

1	Multi Mode (SC) - 2Km
2	Multi Mode (ST) - 2Km
6	Multi Mode (SC) WDM-TX:1310nm/RX:1550nm - 2Km
7	Multi Mode (SC) WDM-TX:1550nm/RX:1310nm - 2Km
8	Multi Mode (SC) WDM-TX:1310nm/RX:1550nm - 5Km
9	Multi Mode (SC) WDM-TX:1550nm/RX:1310nm - 5Km
A	Single Mode (SC) - 20Km
B	Single Mode (SC) - 40Km
H	Single Mode (ST) - 20Km
P	Single Mode (SC) WDM-TX:1310nm/RX:1550nm - 20Km
Q	Single Mode (SC) WDM-TX:1550nm/RX:1310nm - 20Km
R	Single Mode (SC) WDM-TX:1310nm/RX:1550nm - 40Km
S	Single Mode (SC) WDM-TX:1550nm/RX:1310nm - 40Km

**More 100FX Fiber options also available upon request.*

Optional Accessories

KP-AA96-480	Panel Mounting Kit
KR-BK-43-400	Rack Mounting Kit
GS120A-48	120W/2.5A 48VDC Power Adapter with Latched DC Jack in Plastic Housing (for DC Jack)
DR-120-48	120W/2.5A DIN-Rail 48VDC Industrial Power Supply (for Terminal Block)

EX43000 Series

Industrial Unmanaged 8-port 10/100BASE Ethernet Switch



Overview

EtherWAN's EX43000 Series is an industrial unmanaged Fast Ethernet switching platform, designed for easy deployment in industrial environments.

The EX43000 Series is equipped with eight Fast Ethernet ports, or a combination of Fast Ethernet copper ports and two 100FX ports for long distance connectivity. This versatile switch features 10/100Mbps transfer speeds, full/half-duplex auto-negotiation and auto MDI/MDIX operation allowing you to connect your network devices without hassles.

The EX43000 is feature-rich with full wire speed Fast Ethernet throughput, QoS (Quality of Service), IEEE802.3az EEE (Energy Efficient Ethernet) and Broadcast storm protection. The EX43000 Series is built with relay alarm to notify users when power fails or link down occurs. It also supports Broadcast storm protection by enabling the DIP switch. The EX43000 Series is housed with a DIN rail mountable metal compact case which is an ideal solution for network applications in harsh environments.

EtherWAN – "When Connectivity is Crucial."

Spotlight

• Industrial Grade

- Supports -20°C to 60°C (-4°F to 140°F) operating temperature

• Port Failure Alarm and Broadcast Storm Protection

- Provide relay alarm to notify users when power fails or link down occurs by DIP switch
- Selectable DIP switch to set a threshold level to prevent from performance degradation or network choking

• Fiber Connectivity

- Up to two 100BASE-FX ports with SC, ST, WDM and SFP options

• Energy Efficient Ethernet (EEE)

- Supports IEEE802.3az standard

• High Reliability

- Fanless design
- No moving parts

Hardware Specifications

Technology

Standards

- IEEE802.3u 100BASE-TX/FX
- IEEE802.3x full-duplex flow control
- IEEE802.3az Energy Efficient Ethernet
- IEEE802.1p Quality of Service (QoS)

Forward and Filtering Rate

- 14,880pps for 10Mbps
- 148,810pps for 100Mbps

Packet Buffer Memory

- 448K bits

Processing Type

- Store-and-Forward
- Auto Negotiation
- Half-duplex back-pressure and IEEE802.3x full-duplex flow control
- Auto MDI/MDIX

Address Table Size

- 1K MAC addresses

Power

Input Voltage

- 12 to 48VDC (Terminal Block)

Power Consumption

- 2.47W@24VDC

Protection

- Reverse polarity protection

Mechanical

Casing

- Aluminum case
- IP30

Dimensions

43.6mm (W) x 110mm (D) x 135mm (H)
(1.74" (W) x 4.33" (D) x 5.31" (H))

Weight

- 0.51Kg (1.12lbs)

Installation

- DIN-Rail (Top hat type 35mm) or Panel mounting

Interface

Ethernet Ports

- 10/100BASE-TX: 8 or 6 ports
- 100BASE-FX: 0 or 2 ports

LED Indicators

- Per Unit: Power 1 (Green),
Power 2 (Green)
- Per Port: Link/Activity (Green)

Alarm Contact

- One relay output with current 1A @ 250VAC
- Supports normal close and normal open

Environment

Operating Temperature

- -20°C to 60°C (-4°F to 140°F)
Tested @ -30°C to 70°C (-22°F to 158°F)

Storage Temperature

- -40°C to 85°C (-40°F to 185°F)

Ambient Relative Humidity

- 5% to 95% (non-condensing)

Regulatory Approvals

ISO

- Manufactured in an ISO9001 facility

Safety

UL60950-1 (Pending)

EMI

FCC Part 15B, Class A

VCCI Class A

EN61000-6-4

EN55022 Class A

EMS

EN61000-6-2

- EN61000-4-2 (ESD Standards)
- EN61000-4-3 (Radiated RFI Standards)
- EN61000-4-4 (Burst Standards)
- EN61000-4-5 (Surge Standards)
- EN61000-4-6 (Induced RFI Standards)
- EN61000-4-8 (Magnetic Field Standards)

Environmental Test Compliances

IEC60068-2-6 Fc (Vibration)

IEC60068-2-27 Ea (Shock)

FED STD 101C Method 5007.1 (Free fall w/ package)

Dimensions

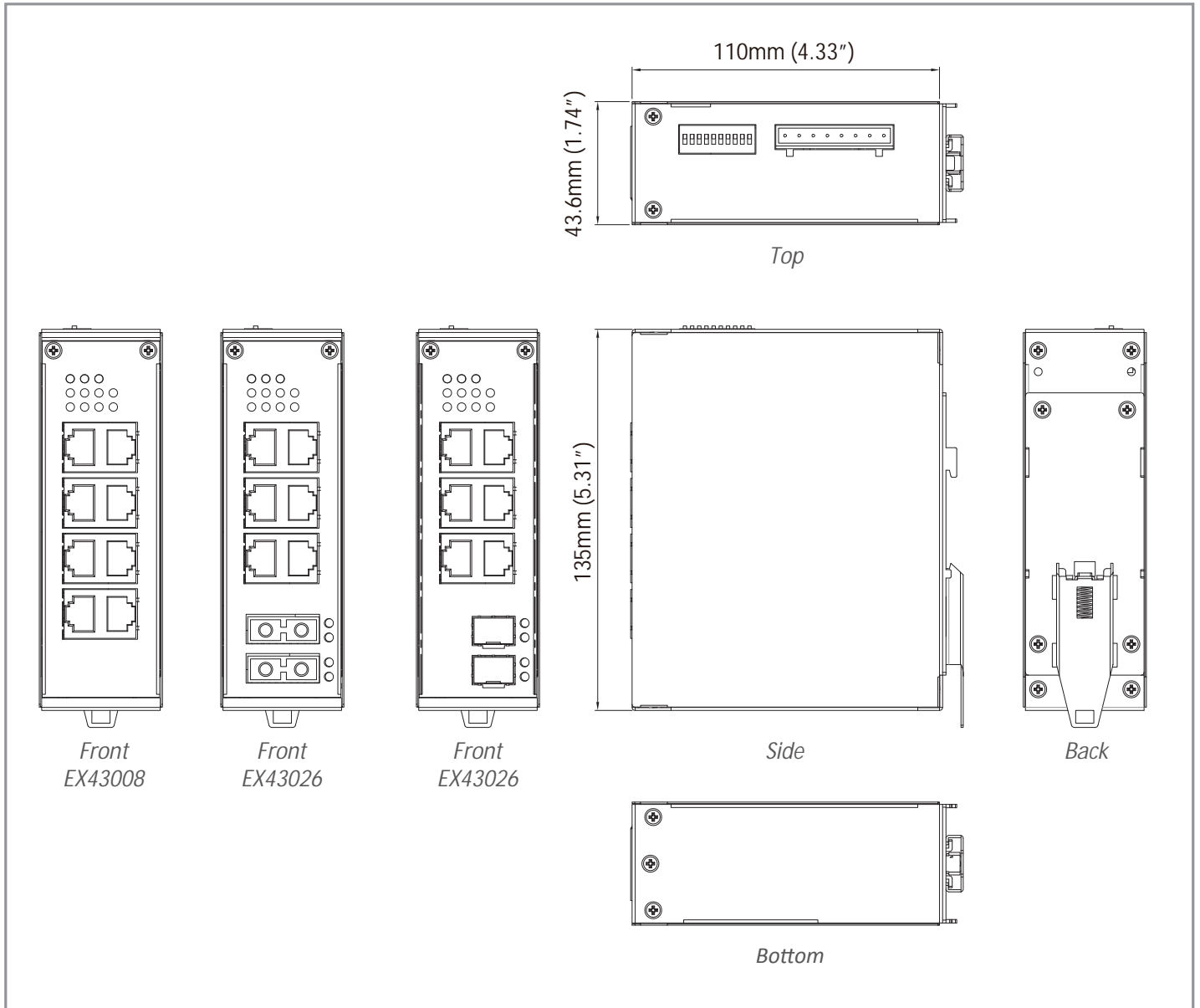

Ordering Information

Model

EX43008-00-I-AA	Industrial Unmanaged 8-port 10/100BASE-TX Ethernet Switch
EX43026-XY-I-AA	Industrial Unmanaged 6-port 10/100BASE-TX + 2-port 100BASE-FX Ethernet Switch

* DIN-Rail mounting kit included

100FX Fiber Options (XY)

1A	Multi Mode (SC) - 2Km
1B	Multi Mode (ST) - 2Km
2A	Single Mode (SC) - 20Km
2D	Single Mode (ST) - 20Km
2E	Single Mode (SC) WDM -TX:1310nm/RX:1550nm - 20Km
2G	Single Mode (SC) WDM -TX:1550nm/RX:1310nm - 20Km
V	100BASE SFP

* More 100FX Fiber options also available upon request.

Optional Accessories

KP-AA96-480	Panel Mounting Kit
KR-BKEL900	Rack Mounting Kit
DR-30-24	30W/1.5A DIN-Rail 24VDC Industrial Power Supply (for Terminal Block)
DR-60-24	60W/2.5A DIN-Rail 24VDC Industrial Power Supply (for Terminal Block)
DR-75-24	75W/3.2A DIN-Rail 24VDC Industrial Power Supply (for Terminal Block)

EX42000 Series

Industrial Unmanaged 5-port 10/100BASE Ethernet Switch



Overview

EtherWAN's EX42000 Series is a compact Industrial Unmanaged Fast Ethernet switching platform, designed for easy deployment in harsh environments.

The EX42000 Series is equipped with 5 Fast Ethernet copper ports, or a combination of 4 Fast Ethernet copper ports and 1 Fast Ethernet fiber port for long distance connectivity. This versatile switch features 10/100Mbps transfer speeds, full/half-duplex auto-negotiation and auto MDI/MDIX operation allowing you to connect your network devices without hassles.

Although unmanaged, the EX42000 is feature-rich with full wire speed Fast Ethernet throughput, QoS (Quality of Service), and IEEE802.3az EEE (Energy Efficient Ethernet). The EX42000 can be DIN rail mounted and features a compact casing that can be an ideal solution for factory floors, warehouses, and outdoor locations without temperature control.

EtherWAN – “When Connectivity is Crucial.”

Spotlight

• Industrial Grade

- Supports -10°C to 60°C (14°F to 140°F) operating temperature
- Supports DIN-Rail mounting

• Fiber Connectivity

- Up to one 100BASE-FX port with SC and ST options

Hardware Specifications

Technology

Standards

- IEEE802.3u 100BASE-TX/FX
- IEEE802.3x full-duplex flow control
- IEEE802.3az Energy Efficient Ethernet
- IEEE802.1p Quality of Service (QoS)

Forward and Filtering Rate

- 14,880pps for 10Mbps
- 148,810pps for 100Mbps

Packet Buffer Memory

- 448K bits

Processing Type

- Store-and-Forward
- Auto Negotiation
- Half-duplex back-pressure and IEEE802.3x full-duplex flow control
- Auto MDI/MDIX

Address Table Size

- 1K MAC addresses

Power

Input Voltage

- Terminal block: 12 to 48VDC

Power Consumption

- 2.12W Max. 0.17A @ 12VDC, 0.08A @ 24VDC, 0.04A @ 48VDC

Protection

- Reverse polarity protection
- Overload current protection

Mechanical

Casing

- Plastic case
- IP30

Dimensions

- 26mm (W) x 70mm (D) x 110mm (H)
(1.02" (W) x 2.76" (D) x 4.33" (H))

Weight

- 0.2Kg (0.44lbs.)

Installation

- DIN-Rail (Top hat type 35mm)

Interface

Ethernet Ports

- 10/100BASE-TX: 5 or 4 ports
- 100BASE-FX: 0 or 1 port

LED Indicators

- Per Unit: Power (Green)
- Per Port: Link/Activity (Green), Speed (Yellow)

Environment

Operating Temperature

- -10°C to 60°C (14°F to 140°F)
Tested @ -20°C to 70°C (-4°F to 158°F)

Storage Temperature

- -40°C to 85°C (-40°F to 185°F)

Ambient Relative Humidity

- 5% to 95% (non-condensing)

Regulatory Approvals

ISO

- Manufactured in an ISO9001 facility

Safety

UL60950

EMI

FCC Part 15B, Class A

VCCI Class A

EN61000-6-4

EMS

EN61000-6-2

- EN61000-4-2 (ESD Standards)
- EN61000-4-3 (Radiated RFI Standards)
- EN61000-4-4 (Burst Standards)
- EN61000-4-5 (Surge Standards)
- EN61000-4-6 (Induced RFI Standards)
- EN61000-4-8 (Magnetic Field Standards)

Environmental Test Compliances

IEC60068-2-6 Fc (Vibration)

IEC60068-2-27 Ea (Shock)

FED STD 101C Method 5007.1 (Free fall w/ package)

Dimensions

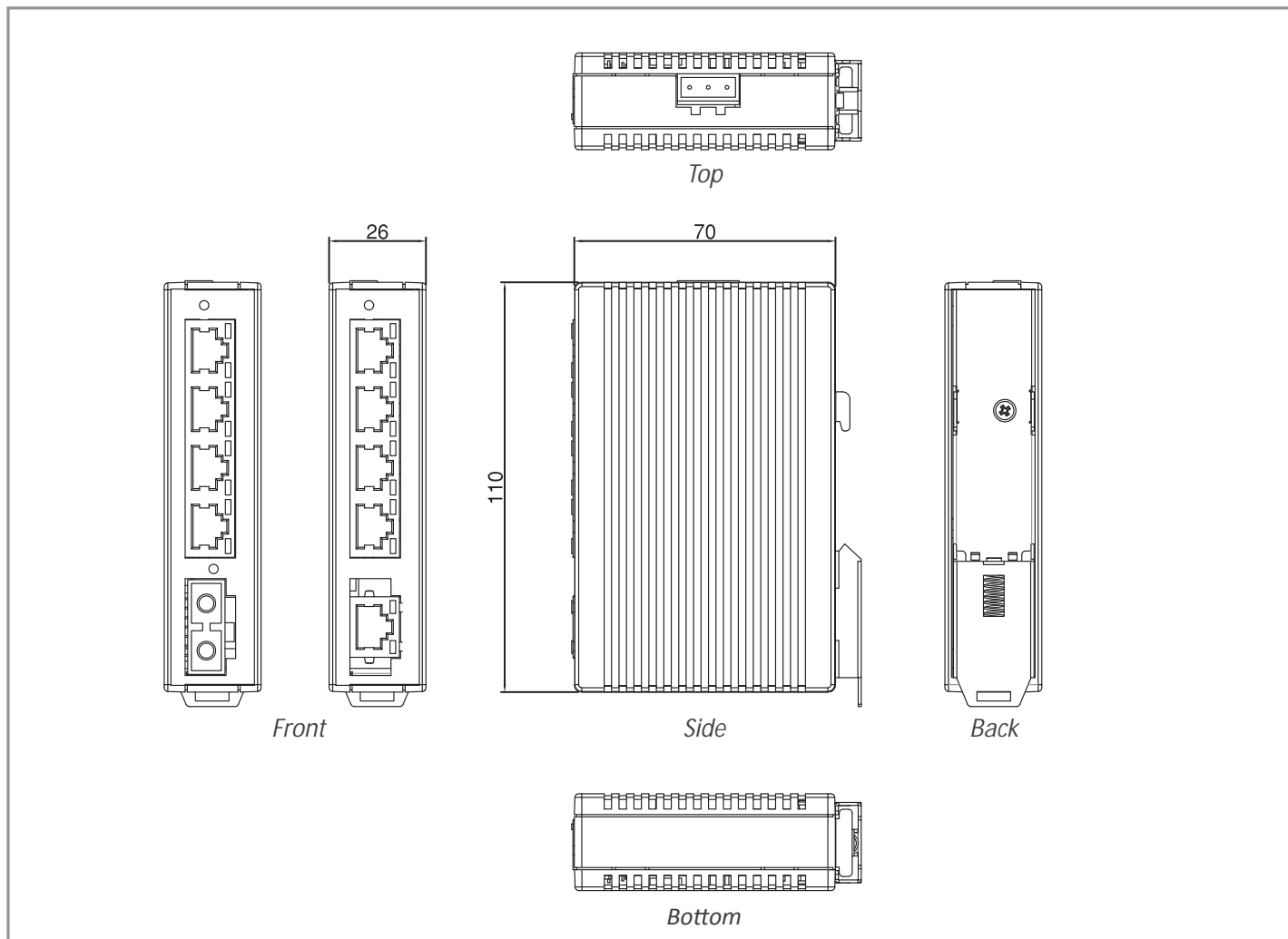

Ordering Information

Model

EX42005-00-1-A	Industrial Unmanaged 5-port 10/100BASE-TX Ethernet Switch
EX42014-XY-1-A	Industrial Unmanaged 4-port 10/100BASE-TX + 1-port 100BASE-FX Ethernet Switch

* DIN-Rail mounting kit included

100FX Fiber Options (XY)

1A	Multi Mode (SC) - 2Km
1B	Multi Mode (ST) - 2Km
2A	Single Mode (SC) - 20Km
2D	Single Mode (ST) - 20Km
2E	Single Mode (SC) WDM-TX: 1310nm/RX:1550nm - 20Km
2G	Single Mode (SC) WDM-TX: 1550nm/RX:1310nm - 20Km

* More 100FX fiber options also available upon request

Ordering Information - continued

Optional Accessories

DR-30-24	30W/1.5A DIN-Rail 24VDC Industrial Power Supply (for Terminal Block)
DR-60-24	60W/2.5A DIN-Rail 24VDC Industrial Power Supply (for Terminal Block)
DR-75-24	75W/3.2A DIN-Rail 24VDC Industrial Power Supply (for Terminal Block)
DR-120-24	120W/5A DIN-Rail 24VDC Industrial Power Supply (for Terminal Block)
41-136046-X	36W/3A 12VDC hardened power adapter with open wire in aluminum housing (for Terminal Block) (X) = 1: US, 2: EU, 3: UK, 4: AU, 5: JP, 6: SA

EX24402

Managed 16-port 10/100BASE PoE with 2-port Gigabit SFP Combo Ethernet Switch



Overview

The EX24402 Managed 10/100BASE PoE Ethernet Switch is an ideal choice for your large, managed enterprise network. It packs 16 autosensing 10/100BASE Ethernet ports plus two SFP combo slots for Gigabit uplinks into a compact chassis that takes only 1U of rack space.

The switch acts as a PoE power source device, enabling you to supply power to PoE end devices such as wireless access points, IP cameras, VoIP phones, etc, on your 10/100BASE network. By using PoE, you free yourself from restrictions imposed by limited AC outlets and you can centralize your power distribution and backup power.

The 16 auto negotiating PoE ports provide up to 15.4 watts each for all ports, up to a total power budget of 195 watts. The EX24402 is equipped with EtherWAN's Alpha-Ring self-healing ring technology providing less than 15ms fault recovery time. Users are able to access management features such as port security, IGMP snooping, port-based VLAN, GARP protocols, link aggregation, via web browser, telnet, SSH, SNMP, RMON, TFTP, and RS-232 console interfaces.

EtherWAN — "When Connectivity is Crucial."

Spotlight

• PoE Connectivity

- Sixteen 10/100BASE IEEE802.3af Power over Ethernet ports
- Two Gigabit SFP combo ports

• Intelligent Management

- Optimize network performance with QoS, VLAN, and PoE scheduling, etc. Network redundancy is secured by EtherWAN's α -Ring, with fault recovery time $< 15\text{ms}$

• Remote Secure Access

- IEEE802.1x, and RADIUS support

Software Features

Management

- Interface
 - CLI, Telnet and Web Browser
 - SNMP v1/v2c/v3
- Firmware and configuration upgrade and backup via TFTP
- Supports DHCP Server/Client
- RMON (Remote monitoring): group 1, 2, 3, 9
- Port mirroring: TX/RX and both
- NTP (Network Time Protocol) time synchronization
- IEEE802.1ab LLDP (Link Layer Discovery Protocol)

Security

- MAC address filtering
- Enable/disable port
- Storm control (broadcast and multicast types)
- IEEE802.1x LAN access control
- Remote authentication through RADIUS
- SSH for CLI and Telnet security
- SSL for web security
- Multi-level user account/password against unauthorized configuration
- System log (remote/local)

Quality of Service (QoS)

- Priority Queues: 4 queues per port
- Traffic classification based on IEEE802.1p CoS, DSCP, WRR (Weighted round robin) and strict mode
- Rate Limiting (Ingress/Egress)

Layer 2 Features

- Auto-negotiation for port speed and duplex mode
- Flow Control
 - IEEE802.3x full duplex mode
 - Back-Pressure half duplex mode
- Redundant Protocol
 - IEEE802.1D Spanning Tree Protocol (STP)
 - IEEE802.1w Rapid Spanning Tree Protocol (RSTP)
 - IEEE802.1s Multiple Spanning Tree Protocol (MSTP)
 - Supports EtherWAN's Alpha-Ring topology for less than 15ms fault recovery time

Performance

- Switching Capability: 7.2Gbps
- Packet Buffer Size: 2M
- MAC Address Table: 8192

Hardware Specifications

Technology

Standards

- IEEE802.3 10BASE-T
- IEEE802.3u 100BASE-TX/100BASE-FX
- IEEE802.3ab 1000BASE-T
- IEEE802.3z 1000BASE-SX/1000BASE-LX
- IEEE802.3x Full duplex and flow control
- IEEE802.1p QoS
- IEEE802.1Q Tag VLANs
- IEEE802.1w RSTP
- IEEE802.1x Port-based Network Access Control
- IEEE802.3af Power over Ethernet (PoE)

Forward and Filtering Rate

- 14,880pps for 10Mbps
- 148,810pps for 100Mbps
- 1,488,100pps for 1000Mbps

Packet Buffer Memory

- 2M bits

Processing Type

- Store-and-Forward
- Auto Negotiation
- Half-duplex back-pressure and IEEE802.3x full-duplex flow control
- Auto MDI/MDIX

Address Table Size

- 8192 MAC addresses

Power

Input

- 100 to 240VAC, 50/60Hz

Power Consumption

- Max. 12W (without PoE)
- PoE power budget (depends on power input): 195W

PoE Power Output

- IEEE802.3af: up to 15.4W/port

Protection

- Overload current protection
- Reverse polarity protection

Mechanical

Casing

- Metal Case
- IP30

Dimensions

- 443.6mm (W) x 285mm (D) x 44mm (H)
(17.5" (W) x 11.2" (D) x 1.73" (H))

Weight

- 3.8Kg (8.38lbs.)

Installation

- Rack mounting

Interface

Ethernet Port

- 10/100BASE-TX: 16 ports
- 100BASE-FX: N/A
- Gigabit: 2 ports

Console Port

- Port: One DB9 RS-232 port

LED Indicators

- Per Unit: Power 1
- Per PoE Port: PoE (Amber)
- Per Port: Link/Act (Green), Speed (Green)

Environment

Operating Temperature

- 0°C to 45°C (32°F to 113°F)

Storage Temperature

- -10°C to 70°C (14°F to 158°F)

Ambient Relative Humidity

- 5% to 95% (non-condensing)

Regulatory Approvals

ISO

- Manufactured in an ISO9001 facility

EMI

FCC Part 15B, Class A

EN61000-6-4

EN55022

EN61000-3-2

EN61000-3-3

EMS

EN61000-6-2

- EN61000-4-2 (ESD Standards)
- EN61000-4-3 (Radiated RFI Standards)
- EN61000-4-4 (Burst Standards)
- EN61000-4-5 (Surge Standards)
- EN61000-4-6 (Induced RFI Standards)
- EN61000-4-8 (Magnetic Field Standards)

Environmental Test Compliance

IEC60068-2-6 Fc (Vibration Resistance)

IEC60068-2-27 Ea (Shock)

FED STD 101C Method 5007.1 (Free fall w/package)

Application Diagram

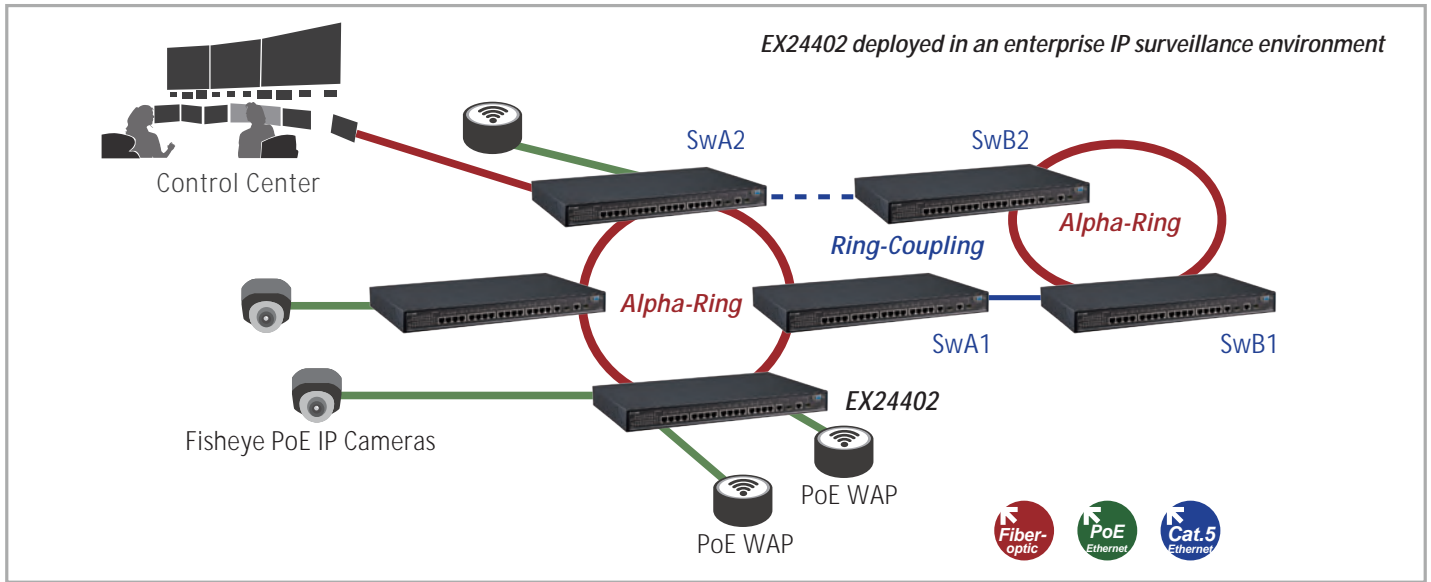

Dimensions

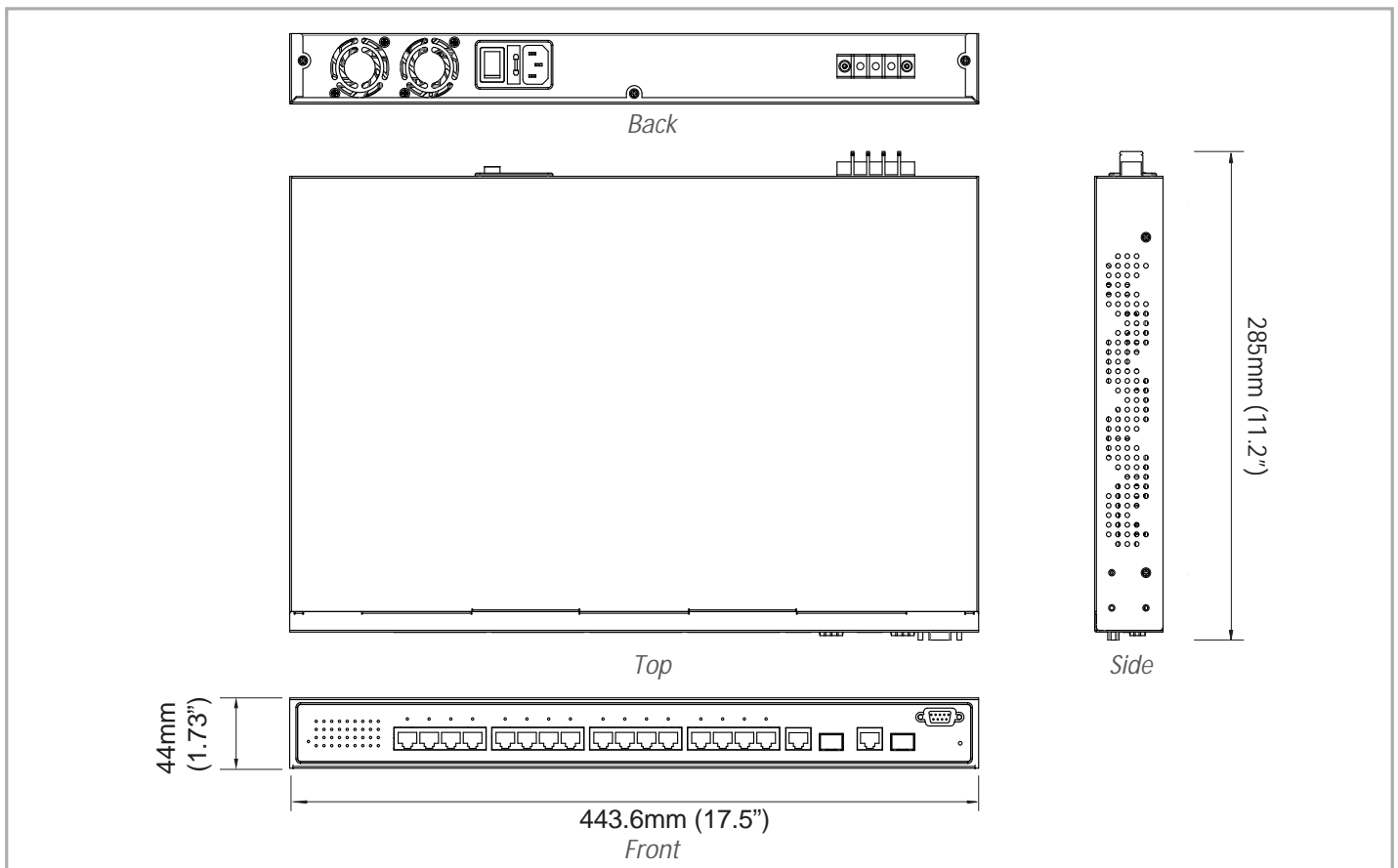

Ordering Information

Models

EX24402-0VCU	Managed 16-port 10/100BASE PoE with 2-port Gigabit SFP Combo Ethernet Switch
--------------	--

EX26262

Web-managed 26-port Gigabit PoE Switch
with 24 Gigabit + 2 SFP ports



Overview

EtherWAN's EX26262 provides a 26-port switching platform supporting IEEE802.3at Power over Ethernet, high performance switching with management features required for enterprise environments where sustained connectivity is crucial.

The EX26262 is equipped with 24 10/100/1000BASE-TX PoE ports, in combination with 2 Gigabit SFP options. The EX26262 is feature rich with 10K Jumbo Frame support, full wire speed Gigabit throughput, QoS support, making the EX26262 Series a powerful network switch.

The IEEE802.3at PoE ports provide up to 30W/port with a total power budget of 190W, making the switch truly versatile for connecting with PoE Powered Devices (PD) with different bandwidth and power consumption requirements such as outdoor PTZ dome cameras, wireless access points, and way-side communication devices.

Users are able to access management features such as port security, IGMP snooping, VLANs, GARP protocols, LACP, and via web browser, SNMP and RMON interfaces.

Spotlight

• IEEE802.3at Power over Ethernet

- Max. PoE output power per port up to 30W, with max. PoE power budget 190W

• High Switching Performance

- 52Gbps wire-speed switching performance across all 26 ports

• Web-managed Interface

- Comprehensive QoS based on 802.1p, DSCP, and IP precedence
- High availability based on RSTP/MSTP/LACP
- Integrated port security with ACL and 802.1x

Software Features

Management

- Interface
 - CLI, Telnet and Web Browser
 - SNMP v1/v2c/v3
- Firmware and configuration upgrade and backup via TFTP
- LLDP / LLDP-MED
- Supports DHCP Client
- RMON (Remote monitoring): group 1, 2, 3, 9
- Port mirroring: TX/RX and both

Security

- MAC address filtering
- Enable/disable port
- Storm control (broadcast and multicast types)
- IEEE802.1x LAN access control
- Remote authentication through RADIUS
- SSH for CLI and Telnet security
- SSL for web security
- ACL

Quality of Service (QoS)

- Priority Queues: 8 queues per port
- Traffic classification based on IEEE802.1p CoS, DSCP, WRR (Weighted round robin) and strict mode
- Rate Limiting (Ingress/Egress)

Layer 2 Features

- Auto-negotiation for port speed and duplex mode
- Flow Control
 - IEEE802.3x full duplex mode
 - Back-Pressure half duplex mode
- Redundant Protocol
 - IEEE802.1D Spanning Tree Protocol (STP)
 - IEEE802.1w Rapid Spanning Tree Protocol (RSTP)
 - IEEE802.1s Multiple Spanning Tree Protocol (MSTP)
- VLANs
 - Port-based VLANs
 - IEEE802.1Q Tag VLANs
- Link Aggregation
 - Static Trunk (13 groups, 12 ports per group)
 - IEEE802.3ad Link Aggregation Control Protocol
- IGMP Snooping
 - IGMP snooping v1/v2/v3
 - IGMP immediate leave

Performance

- Switching Capability: 52Gbps
- Packet Buffer Size: 512KB
- MAC Address Table: 8K
- Jumbo frame: 10K

Hardware Specifications

Technology

Standards

- IEEE802.3 10BASE-T
- IEEE802.3u 100BASE-TX/100BASE-FX
- IEEE802.3ab 1000BASE-T
- IEEE802.3z 1000BASE-SX/1000BASE-LX
- IEEE802.3x Full duplex and flow control
- IEEE802.1p QoS
- IEEE802.1Q Tag VLANs
- IEEE802.1s MSTP
- IEEE802.1w, RSTP
- IEEE802.1x Port-based Network Access Control
- IEEE802.3ad LACP
- IEEE802.3at Power over Ethernet

Forward and Filtering Rate

- 14,880pps for 10Mbps
- 148,810pps for 100Mbps
- 1,488,100pps for 1000Mbps

Packet Buffer Memory

- 10K

Packet Buffer

- 512KB

Address Table Size

- 8K MAC address

Power

Input

- 100 to 240VAC, 50/60Hz

Power Consumption

- Device: Max. 25W (without PoE)
- PoE power budget: 190W Max.

PoE Power Output

- IEEE802.3at: up to 30W/port, 50VDC, 600mA

Mechanical

Casing

- Metal Case

Dimensions

- 440mm(W) x 350mm(D) x 44mm(H)
(17.3" (W) x 13.8" (D) x 1.73" (H))
- Standard 19" rack-mount size, one-unit-height

Weight

- 4.5Kg (9.92lbs.)

Installation

- Rack mounting

Interface

Ethernet Port

- 10/100/1000BASE-T: 24 ports
- 100/1000BASE-X SFP 2 ports

LED Indicators

- Per Unit: PWR, DIAG
- Per Port: Link/ACT, PoE

Environment

Operating Temperature

- 0°C to 50°C (32°F to 122°F)

Storage Temperature

- -40°C to 70°C (-40°F to 158°F)

Ambient Relative Humidity

- 5% to 95% (non-condensing)

Regulatory Approvals

ISO

- Manufactured in an ISO9001 facility

Safety

UL60950-1, EN60950-1, IEC60950-1

EMI

CE Mark Class A, FCC Part 15 ClassA

Application Diagram

The EX26262 PoE/PSE connects up to 24 PoE powered devices



Dimensions

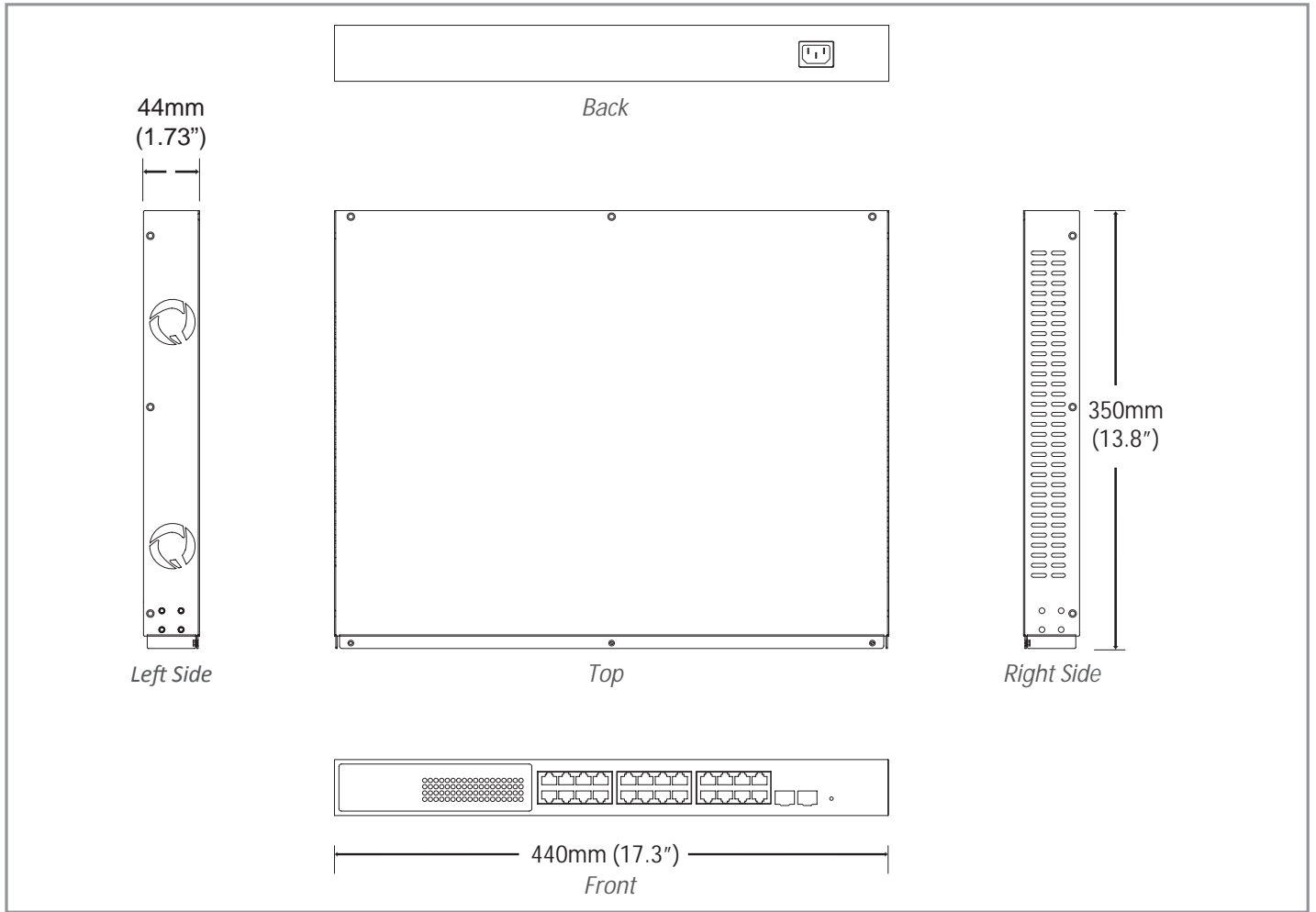

Ordering Information

Model

EX26262	Web-managed 26-port Gigabit PoE Switch with 24 Gigabit + 2 SFP ports
---------	--

* Rack mounting kit included

EX26182

Web-Managed 18-port Gigabit PoE Switch
with 16 Gigabit + 2 SFP ports



Overview

EtherWAN's EX26182 provides a 18-port switching platform supporting IEEE802.3at Power over Ethernet, high performance switching with management features required for enterprise environments where sustained connectivity is crucial.

The EX26182 is equipped with 16 10/100/1000BASE-TX PoE ports, in combination with two Gigabit SFP options. The EX26182 is feature-rich with 10K Jumbo Frame support, full wire speed Gigabit throughput, QoS support, making the EX26182 Series a powerful network switch.

The IEEE802.3at PoE ports provide up to 30W/port with a total power budget of 190W, making the switch truly versatile for connecting with PoE Powered Devices (PD) with different bandwidth and power consumption requirements such as outdoor PTZ dome cameras, wireless access points, and way-side communication devices.

Users are able to access management features such as port security, IGMP snooping, VLANs, GARP protocols, LACP, and via web browser, SNMP and RMON interfaces.

EtherWAN — "When Connectivity is Crucial."

Spotlight

- **IEEE802.3at Power over Ethernet**
 - Max. PoE output power per port up to 30W, with max. PoE power budget 190W
- **High Switching Performance**
 - 36Gbps wire-speed switching performance across all 18 ports
- **Web-Managed Interface**
 - Comprehensive QoS based on 802.1p, DSCP, and IP precedence
 - High availability based on RSTP/MSTP/LACP
 - Integrated port security with ACL and 802.1x

Software Features

Management

- Interface
 - CLI, Telnet and Web Browser
 - SNMP v1/v2c/v3
- Firmware and configuration upgrade and backup via TFTP
- LLDP / LLDP-MED
- Supports DHCP Client
- RMON (Remote monitoring): group 1, 2, 3, 9
- Port mirroring: TX/RX and both

Security

- MAC Address by port security
- Enable/disable port
- Storm control (broadcast and multicast types)
- IEEE802.1x LAN access control
- Remote authentication through RADIUS
- SSH for CLI and Telnet security
- SSL for web security
- ACL

Quality of Service (QoS)

- Priority Queues: 8 queues per port
- Traffic classification based on IEEE802.1p CoS, DSCP, WRR (Weighted round robin) and strict mode
- Rate Limiting (Ingress/Egress)

Layer 2 Features

- Auto-negotiation for port speed and duplex mode
- Flow Control
 - IEEE802.3x full duplex mode
 - Back-Pressure half duplex mode
- Redundant Protocol
 - IEEE802.1D Spanning Tree Protocol (STP)
 - IEEE802.1w Rapid Spanning Tree Protocol (RSTP)
 - IEEE802.1s Multiple Spanning Tree Protocol (MSTP)
- VLANs
 - Port-based VLANs
 - IEEE802.1Q Tag VLANs
- Link Aggregation
 - Static Trunk (13 groups, 12 ports per group)
 - IEEE802.3ad Link Aggregation Control Protocol
- IGMP Snooping
 - IGMP snooping v1/v2/v3
 - IGMP immediate leave

Performance

- Switching Capability: 36Gbps
- Packet Buffer Size: 512KB
- MAC Address Table: 8K
- Jumbo frame: 10K

Hardware Specifications

Technology

Standards

- IEEE802.3 10BASE-T
- IEEE802.3u 100BASE-TX/100BASE-FX
- IEEE802.3ab 1000BASE-T
- IEEE802.3z 1000BASE-SX/1000BASE-LX
- IEEE802.3x Full duplex and flow control
- IEEE802.1p, QoS
- IEEE802.1Q Tag VLANs
- IEEE802.1s MSTP
- IEEE802.1w RSTP
- IEEE802.1x Port-based Network Access Control
- IEEE802.3ad LACP
- IEEE802.3at Power over Ethernet

Forward and Filtering Rate

- 14,880pps for 10Mbps
- 148,810pps for 100Mbps
- 1,488,100pps for 1000Mbps

Packet Buffer Memory

- 10K

Packet Buffer

- 512KB

Address Table Size

- 8K MAC address

Power

Input

- 100 to 240VAC, 50/60Hz

Power Consumption

- Device: Max. 25W (without PoE)
- PoE power budget: 190W Max.

PoE Power Output

- IEEE802.3at: up to 30W/port, 50VDC, 600mA

Mechanical

Casing

- Metal Case

Dimensions

- 440mm(W) x 350mm(D) x 44mm(H)
(17.3" (W) x 13.8" (D) x 1.73" (H))
- Standard 19" rack-mount size, one-unit-height

Weight

- 4.1 Kg (9.0 lbs)

Installation

- Rack mounting

Interface

Ethernet Port

- 10/100/1000BASE-T: 16 ports
- 100/1000BASE-X SFP 2 ports

LED Indicators

- Per Unit: PWR, DIAG
- Per Port: Link/ACT, PoE

Environment

Operating Temperature

- 0°C to 50°C (32°F to 122°F)

Storage Temperature

- -40°C to 70°C (-40°F to 158°F)

Ambient Relative Humidity

- 5% to 95% (non-condensing)

Regulatory Approvals

ISO

- Manufactured in an ISO9001 facility

Safety

UL60950-1, EN60950-1, IEC60950-1

EMI

CE Mark Class A, FCC Part 15 ClassA

Application Diagram

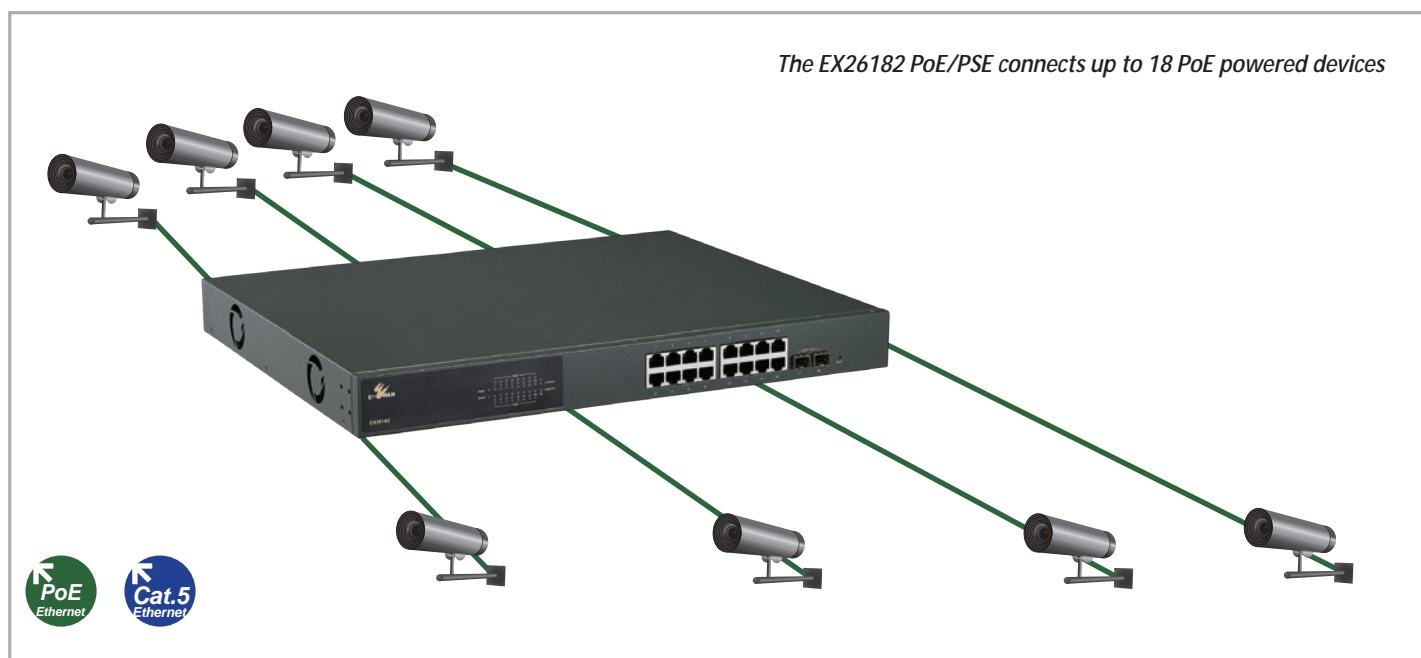

Dimensions

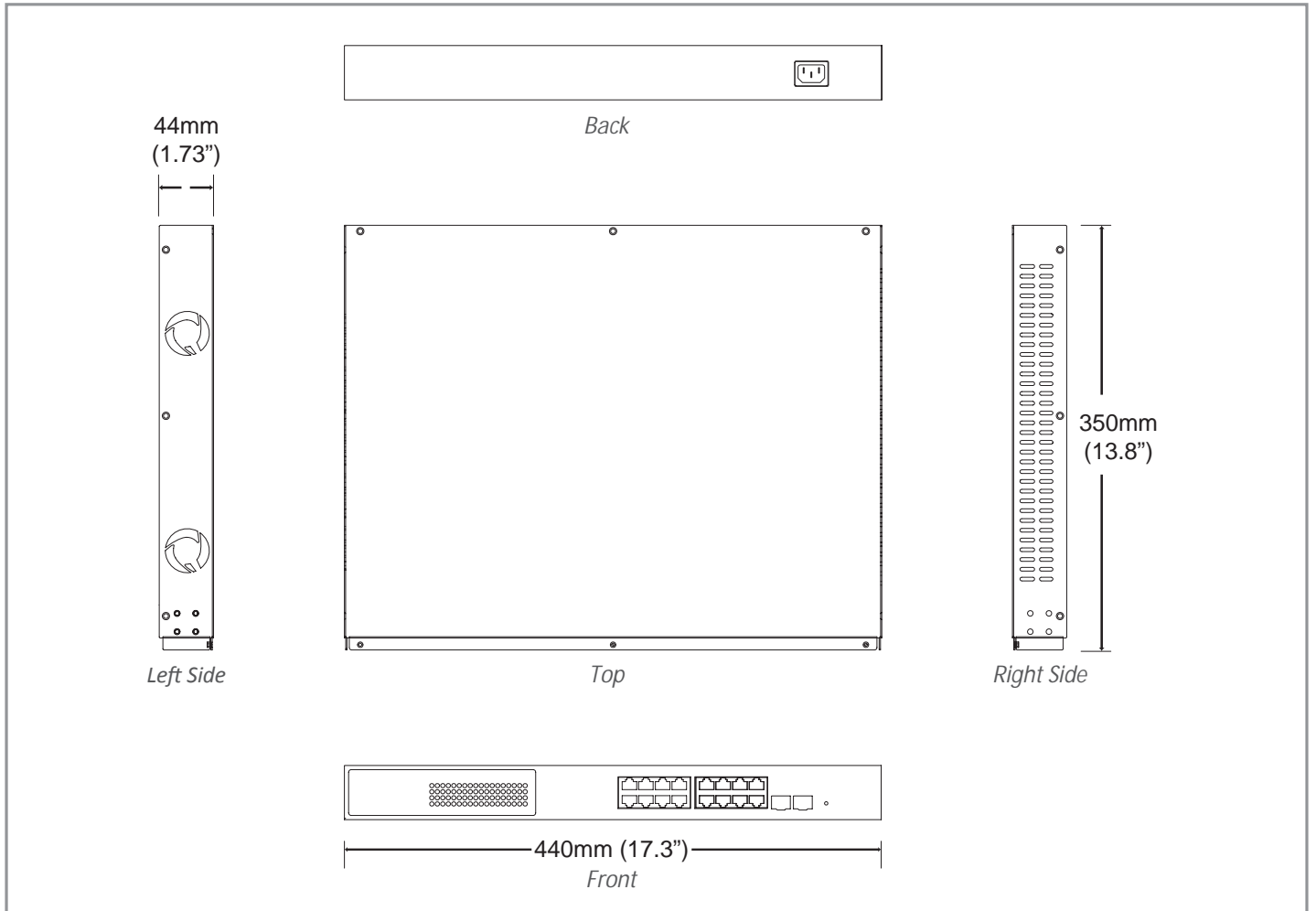

Ordering Information

Model

EX26182	Web-Managed 18-port Gigabit PoE Switch 16 Gigabit + 2 SFP ports
---------	---

* Rack mounting kit included

EX25611

Managed 24-port 10/100/1000BASE-T (4-port SFP Combo)
and 4-port 1G/10G SFP+ Ethernet Switch



Overview

EtherWAN's EX25611 Series is a rack-mount Gigabit switch equipped with twenty-eight ports, or a combination of twenty-four Gigabit copper ports and four 1G/10G SFP+ for connecting the switch to the core network. The EX25611 is a feature-rich and powerful network switch with full wire speed Gigabit throughput ideal for small businesses, the network edge, or workgroups within larger organizations.

The simplified user interface enables users to quickly use the comprehensive feature set of the switch, for a better-optimized network. The EX25611 features comprehensive and useful functions such as DHCP Snooping, QoS, Spanning Tree, RSTP/MSTP, VLAN, Port Trunking, Bandwidth Control, Port Security, SNMP/RMON, LLDP and IGMPv3 Snooping capability via the intelligent software. Users are able to access management features via web browser, Telnet, SNMP, RMON, TFTP, and RS-232 console interfaces.

EtherWAN – “When Connectivity is Crucial.”

Spotlight

- **High Bandwidth**
 - Uplink Ports up to 10Gbps
- **High Switching Performance**
 - 128Gbps wire-speed switching performance across all 28 ports
- **Managed Interface**
 - Comprehensive QoS based on 802.1p, DSCP, and IP precedence
 - High availability based on RSTP/MSTP/LACP
 - Integrated port security with ACL and 802.1x

Software Features

Management

- Interface
 - CLI, Telnet and Web Browser
 - SNMP v1/v2c/v3
- Firmware and configuration upgrade and backup via TFTP
- Supports DHCP Client, DHCP relay with DHCP option 82
- RMON (Remote monitoring): group 1, 2, 3, 9
- Port mirroring: TX/RX and both
- LLDP / LLDP-MED
- IPv4 and IPv6 dual stack

Security

- MAC Address by port security
- IP source guard: supports illegal IP address to specific port
- Enable/disable port
- Storm control (broadcast, multicast and unicast types)
- IEEE802.1x LAN access control
- Remote authentication through RADIUS and TACACS+
- SSH for CLI and Telnet security
- SSL for web security
- ACL

Quality of Service (QoS)

- Priority Queues: 8 queues per port
- Traffic classification based on IEEE802.1p CoS, DSCP, WRR (Weighted Round Robin) and strict mode
- Rate Limiting (Ingress/Egress)
- Supports IPv6 applications (Web, Telnet, ping, SNTP, TFTP, SNMP and Syslog)

Layer 2 Features

- Auto-negotiation for port speed and duplex mode
- Flow Control
 - IEEE802.3x full duplex mode
 - Back-Pressure half duplex mode
- Redundant Protocol
 - IEEE802.1D Spanning Tree Protocol (STP)
 - IEEE802.1w Rapid Spanning Tree Protocol (RSTP)
 - IEEE802.1s Multiple Spanning Tree Protocol (MSTP)
- VLANs
 - Port-based VLANs
 - GVRP
 - IEEE802.1Q Tag VLANs
- Link Aggregation
 - Static Trunk (14 groups, 8 ports per group)
 - IEEE802.3ad Link Aggregation Control Protocol
- IGMP Snooping
 - IGMP Snooping v1/v2/v3
 - MLD v1/v2 Snooping
 - IGMP Querier and Proxy

Performance

- Switching Capability: 128Gbps
- Packet Buffer Size: 3Mbits
- MAC Address Table: 32K
- Jumbo frame: 9K

Hardware Specifications

Technology

Standards

- IEEE802.3 10BASE-T
- IEEE802.3u 100BASE-TX/100BASE-FX
- IEEE802.3ab 1000BASE-T
- IEEE802.3z 1000BASE-SX/1000BASE-LX
- IEEE802.3x Full duplex and flow control
- IEEE802.1p QoS
- IEEE802.1Q Tag VLANs
- IEEE802.1s MSTP
- IEEE802.1w RSTP
- IEEE802.1x Port-based Network Access Control
- IEEE802.3ad LACP

Forward and Filtering Rate

- 14,880pps for 10Mbps
- 148,810pps for 100Mbps
- 1,488,100pps for 1000Mbps
- 14,880,952pps for 10Gbps

Address Table Size

- 32K MAC address

Jumbo Frame

- 9K

Power

Input

- 100 to 240VAC, 50/60Hz

Power Consumption

- 47W Max.

Mechanical

Casing

- Metal Case

Dimensions

- 442mm(W) x 300mm(D) x 44mm(H)
(17.4"(W) x 11.81"(D) x 1.73"(H))
- Standard 19" rack-mount size, one-unit-height

Weight

- 3.9 Kg (8.6 lbs)

Installation

- Rack mounting

Interface

Ethernet Port

- 10/100/1000BASE-T: 20 ports
- 10/1000/1000BASE-T/SFP combo: 4 ports
- 10G SFP+: 4 ports

LED Indicators

- Per Unit: System
- Per Port: Link/ACT, SPEED

Environment

Operating Temperature

- 0°C to 40°C (32°F to 104°F)

Storage Temperature

- -10°C to 70°C (14°F to 158°F)

Ambient Relative Humidity

- 5% to 95% (non-condensing)

Regulatory Approvals

ISO

- Manufactured in an ISO9001 facility

EMI

CE Mark Class A

FCC Part 15 ClassA

VCCI Class A

Application Diagram

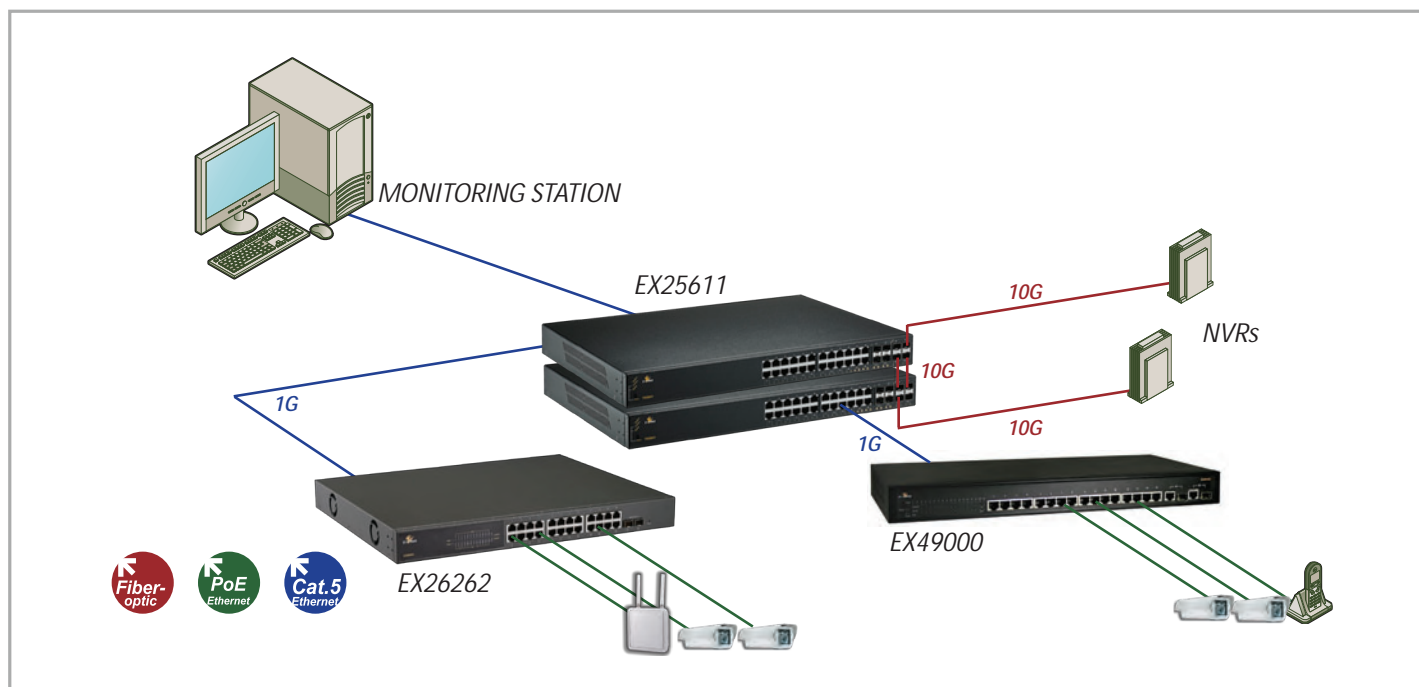

Dimensions

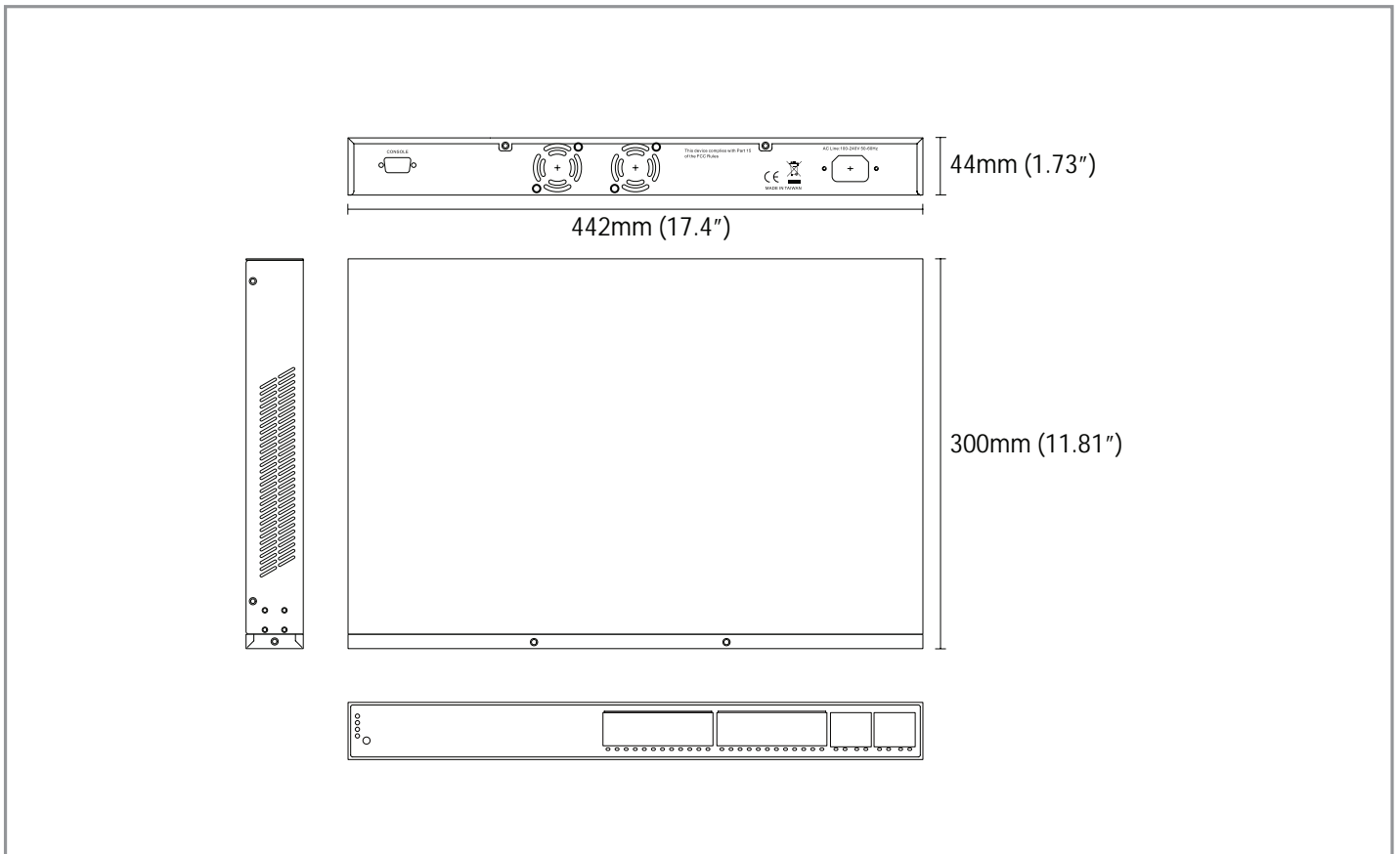

Ordering Information

Model

EX25611	Managed 24-port 10/100/1000BASE-T and 4-port 1G/10G SFP+ Ethernet Switch
---------	--

* Rack mounting kit included

Optional 10G SFP Series

Model Number	Designation	Distance	Wavelength (nm)	Cable Type
EX-LM28-H3S-TC-N	10GBASE-SR	300m	850	Multi-mode OM3 (LC)
EX-LS38-H3S-TC-N	10GBASE-LR	10Km	1310	Single Mode (LC)

*More SFP options also available upon request.

EX17242 Series

Web-smart 24-port 10/100BASE-TX PoE and 2-port combo Gigabit SFP Ethernet Switch



Overview

EtherWAN's EX17242 provides a 26-port switching platform supporting IEEE802.3af Power over Ethernet, high performance switching with features required for small-business or enterprise environments.

The EX17242 is equipped with 24 10/100BASE-TX PoE ports, in combination with two Gigabit SFP options. The EX17242 is feature rich with full wire speed throughput, QoS support, making the EX17242 Series a powerful network switch.

The IEEE802.3af PoE ports provide up to 15.4W/port with a total power budget of 369.6W or 195W, making the switch truly versatile for connecting with PoE Powered Devices (PD) with different bandwidth and power consumption requirements.

Users are able to access management features such as IP configuration, QoS, VLANs, trunking and via web browser interfaces.

Spotlight

• Power over Ethernet

- Supports 24-port IEEE802.3af Power over Ethernet (PoE) and Power Sourcing Equipment (PSE)

• SFP Connectivity

- Built-in 2-port combo Gigabit SFP for either Gigabit copper or SFP connectivity

• Web-Managed Interface

- Comprehensive IP configuration, QoS, VLANs and trunking

Ordering Information

Model

EX17242	Web-smart 24-port 10/100BASE-TX PoE and 2-port combo Gigabit SFP Ethernet Switch (390W)
EX17242L	Web-smart 24-port 10/100BASE-TX PoE and 2-port combo Gigabit SFP Ethernet Switch (195W)

NOTES:

* EX17242 PoE power: 15.4W per port/ 390W per switch

* EX17242L PoE power: 15.4W per 12 port or 7.5W per 24 port/195W per switch

* Rack mounting kit included

Hardware Specifications

Technology

Standards

- IEEE802.3 10BASE-T
- IEEE802.3u 100BASE-TX/100BASE-FX
- IEEE802.3ab 1000BASE-T
- IEEE802.3z 1000BASE-SX/1000BASE-LX
- IEEE802.3x Full duplex and flow control
- IEEE802.1p QoS
- IEEE802.3af Power over Ethernet (PoE)

Forward and Filtering Rate

- 14,880pps for 10Mbps
- 148,810pps for 100Mbps
- 1,488,100pps for 1000Mbps

Packet Buffer Memory

- 2.75M bits

Processing Type

- Store-and-forward
- Auto Negotiation
- Half-duplex back-pressure and IEEE802.3x full-duplex flow control
- Auto MDI/MDIX

Address Table Size

- 4096 MAC addresses

Power

Input

- 100 to 240VAC, 50/60Hz

Power Consumption

- EX17242: 390W Max.; PoE power budget: 369.6W
- EX17242L: 195W Max.; PoE power budget: 180W

PoE Power Output

- IEEE802.3af: up to 15.4W/port, 47 - 55VDC, 350mA Max

Mechanical

Casing

- Metal Case

Dimensions

- 440mm (W) x 330mm (D) x 44mm (H)
(17.32" (W) x 13.2" (D) x 1.73" (H))
- Standard 19" rack-mount size, one-unit-height

Weight

- 4Kg (8.81lbs.)

Installation

- Rack mounting

Interface

Ethernet Port

- 10/100BASE-TX: 24 PoE ports
- Gigabit: 2 ports

LED Indicators

- Per Unit: Power Status
- Per Port 10/100TX: Link/Activity,
- Per Port PoE: Act/status
- Per Port Gigabit: Link/Activity

Environment

Operating Temperature

- 0°C to 45°C (32°F to 113°F)

Storage Temperature

- -10°C to 70°C (14°F to 158°F)

Ambient Relative Humidity

- 10% to 95% (non-condensing)

Regulatory Approvals

ISO

- Manufactured in an ISO9001 facility

EMI

CE Mark Class A, FCC Part 15 ClassA

Dimensions

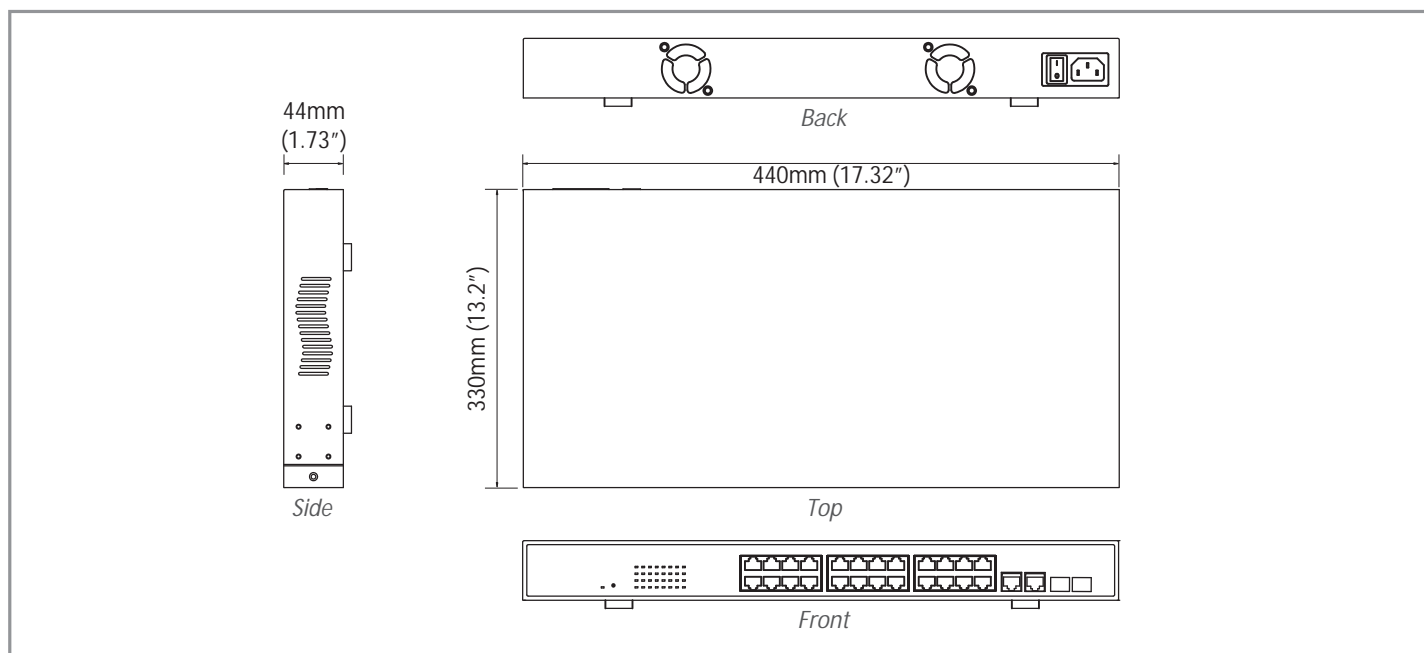

EX1616W Series

Web-Smart 16-port 10/100BASE-TX and 1-port 100BASE-FX
Ethernet Switch



Overview

EtherWAN's EX1616W Series is a Web-smart Fast Ethernet switching platform, designed for easy deployment in small business or enterprise environments.

The EX1616W Series is equipped with sixteen ports, with the combination of sixteen Fast Ethernet copper ports and one expansion fiber slot. Although web-managed, the EX1616W is feature rich with full wire speed Fast Ethernet throughput, making the EX1616W Series a powerful network switch.

Users are able to access management features such as; IP configuration, QoS, VLANs, trunking and via web browser interfaces.

EtherWAN – "When Connectivity is Crucial."

Spotlight

• Fiber Uplink

- Modulized fiber port configurations

• Web-Smart

- Web management for port configuration, port-base VLAN, Trunking and QoS

• Built-in AC Power Supply

- For hassle-free power input

Hardware Specifications

Technology

Standards

- IEEE802.3, 10BASE-T
- IEEE802.3u, 100BASE-TX
- IEEE802.3x, Full duplex flow control

Forward and Filtering Rate

- 14,880pps for 10Mbps
- 148,810pps for 100Mbps

Packet Buffer Memory

- 1.5M bits

Processing Type

- Store-and-Forward
- Auto Negotiation
- Half-duplex back-pressure and IEEE802.3x full-duplex
- flow control
- Auto MDI/MDIX

Address Table Size

- 4096 MAC addresses

Power

Input

- 100 - 240VAC, 50 - 60Hz Internal Universal PSU

Power Consumption

- 11.7W Max. (EX1616W)
- 15.6W Max. (EX1624W)

Mechanical

Casing

- Metal Case

Dimensions

- 440mm (W) x 207mm (D) x 44mm (H)
(17.32" (W) x 8.15" (D) x 1.73" (H))
- Standard 19" rack-mount size, one-unit-height

Weight

- 2.8Kg (6.16lbs.)

Installation

- Rack Mounting

Interface

Ethernet Port

- 10/100BASE-TX: 16 ports
- 100BASE-FX: 1 port

LED Indicators

- Per Unit: Power Status (Power)
- Per Port: 10/100TX, 100FX: Link/Activity

Environment

Operating Temperature

- 0°C to 45°C (32°F to 113°F)

Storage Temperature

- -10°C to 70°C (14°F to 158°F)

Ambient Relative Humidity

- 10% to 95% (non-condensing)

Regulatory Approvals

ISO

- Manufactured in an ISO9001 facility

Emission Compliance

CE Mark Class A

FCC Part 15 B ClassA

Dimensions

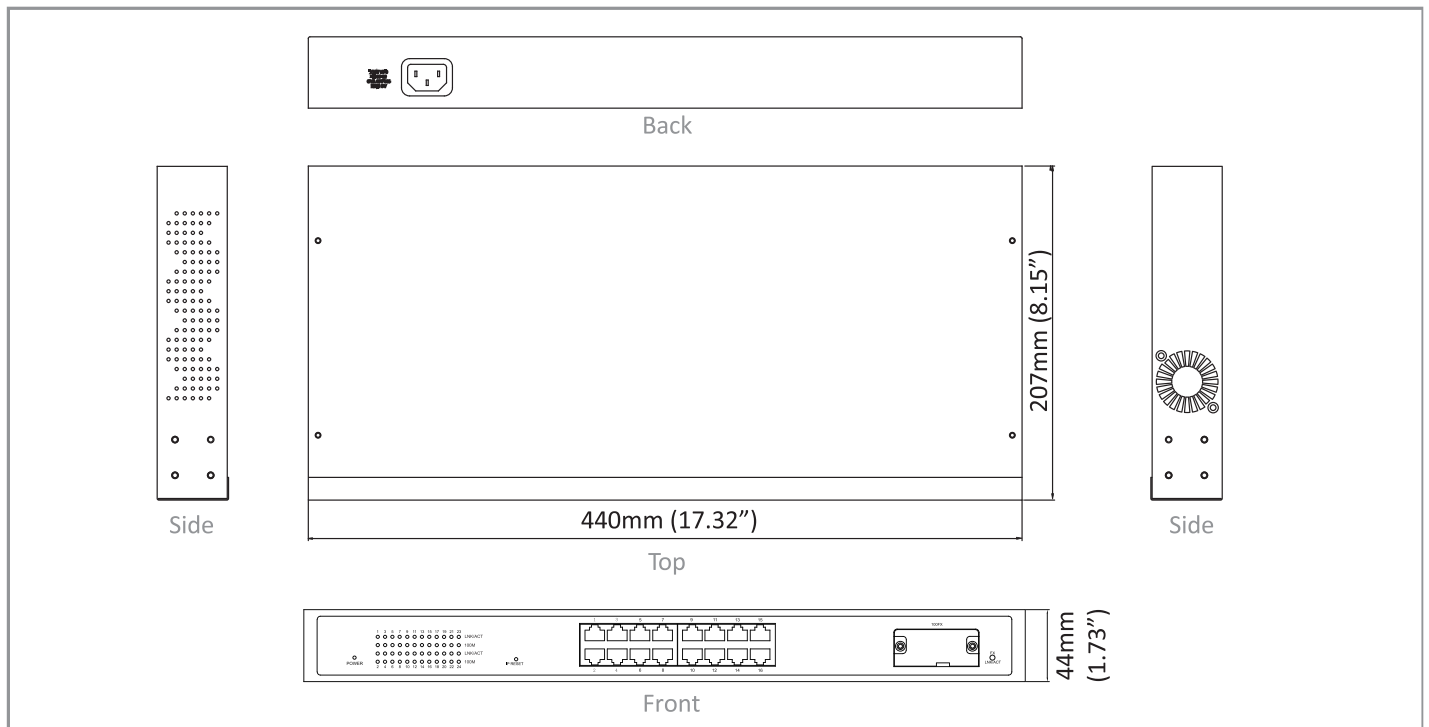

Ordering Information

Model

EX1616W	16-port 10/100BASE-TX + 1 slot for M100M Series Modules
---------	---

M100M Series Modules

FC100M	1-port 100BASE-FX Multi Mode (SC) -2Km Module
FC100M-20	1-port 100BASE-FX Signal Mode (SC) -20Km Module
FM100M	1-port 100BASE-FX Multi Mode (MT-RJ) -2Km Module
FT100M	1-port 100BASE-FX Multi Mode (ST) Module 1-port 100BASE-FX Multi Mode (MT-RJ) -20Km Module
FV100M	1-port 100BASE-FX Multi Mode (VF-45) Module
SFC115M	1-port 100BASE-FX Single Mode (SC) -15Km Module
SFC140M	1-port 100BASE-FX Single Mode (SC) -40Km Module
SFT120M	1-port 100BASE-FX Single Mode (ST) -20Km Module
SFC175M	1-port 100BASE-FX Single Mode (SC) -75Km Module
SFCA120M	1-port 100BASE-FX Single Mode (SC) WDM-TX:1310nm/RX:1550nm -20Km Module
SFCB120M	1-port 100BASE-FX Single Mode (SC) WDM-TX:1550nm/RX:1310nm -20Km Module
SFCA140M	1-port 100BASE-FX Single Mode (SC) WDM-TX:1310nm/RX:1550nm -40Km Module
SFCB140M	1-port 100BASE-FX Single Mode (SC) WDM-TX:1550nm/RX:1310nm -40Km Module

EX17008

Web-smart 8-port 10/100BASE-TX PoE Ethernet Switch



Overview

EtherWAN's EX17008 provides an 8-port switching platform supporting IEEE802.3af Power over Ethernet, high performance switching with features required for enterprise environments.

The EX17008 is equipped with 8 10/100BASE-TX PoE ports. The EX17008 is feature-rich with full wire speed throughput, QoS support, making the EX17008 Series a powerful network switch.

The IEEE802.3af PoE ports provide up to 15.4W/port with a total power budget of 123.2W, making the switch truly versatile for connecting with PoE Powered Devices (PD) with different bandwidth and power consumption requirements.

Users are able to access management features such as; IP configuration, QoS, VLANs, trunking and via web browser interfaces.

EtherWAN — "When Connectivity is Crucial."

Spotlight

- **Power over Ethernet**
 - Supports 8-port IEEE802.3af Power over Ethernet (PoE) and Power Sourcing Equipment (PSE)
- **Web-Managed Interface**
 - Comprehensive IP configuration, QoS, VLANs and trunking

Ordering Information

Model

EX17008	Web-smart 8-port 10/100BASE-TX PoE Ethernet Switch
---------	--

Optional Accessories

KR-BK17	A black metal rack mounting kit consisting of two L-shaped brackets with pre-drilled holes for screws.	Rack mounting kit (black)
---------	--	---------------------------

Hardware Specifications

Technology

Standards

- IEEE802.3 10BASE-T
- IEEE802.3u 100BASE-TX/100BASE-FX
- IEEE802.3x, Full duplex and flow control
- IEEE802.3af, Power over Ethernet

Forward and Filtering Rate

- 14,880pps for 10Mbps
- 148,810pps for 100Mbps

Packet Buffer Memory

- 512K bits

Processing Type

- Store-and-Forward
- Auto Negotiation
- Half-duplex back-pressure and IEEE802.3x full-duplex flow control
- Auto MDI/MDIX

Address Table Size

- 1024 MAC addresses

Power

Input Voltage

- 100 to 240VAC, 50/60Hz

Power Consumption

- Device: Max. 8.8W (without PoE)
- PoE power budget: 123.2W Max.

PoE Power Output

- IEEE802.3af: up to 15.4W/port, 47 - 55VDC, 350mA Max.

Mechanical

Casing

- Metal Case
- IP30

Dimensions

Dimensions

- 266mm (W) x 160mm (D) x 44mm (H)
(10.47" (W) x 6.30" (D) x 1.73" (H))

Weight

- 1.4Kg (3.08lbs.)

Installation

- Desktop, Rack Mounting

Interface

Ethernet Port

- 10/100BASE-TX: 8 PoE ports

LED Indicators

- Per Unit: Power Status
- Per Port: Link/Activity
- Per port PoE: Act/status

Environment

Operating Temperature

- 0°C to 45°C (32°F to 113°F)

Storage Temperature

- -10°C to 70°C (14°F to 158°F)

Ambient Relative Humidity

- 10% to 95% (non-condensing)

Regulatory Approvals

ISO

- Manufactured in an ISO9001 facility

Emission Compliance

FCC Part 15, Class B and CE mark Class B

Safety

UL60950-1, EN60950-1, and IEC60950-1

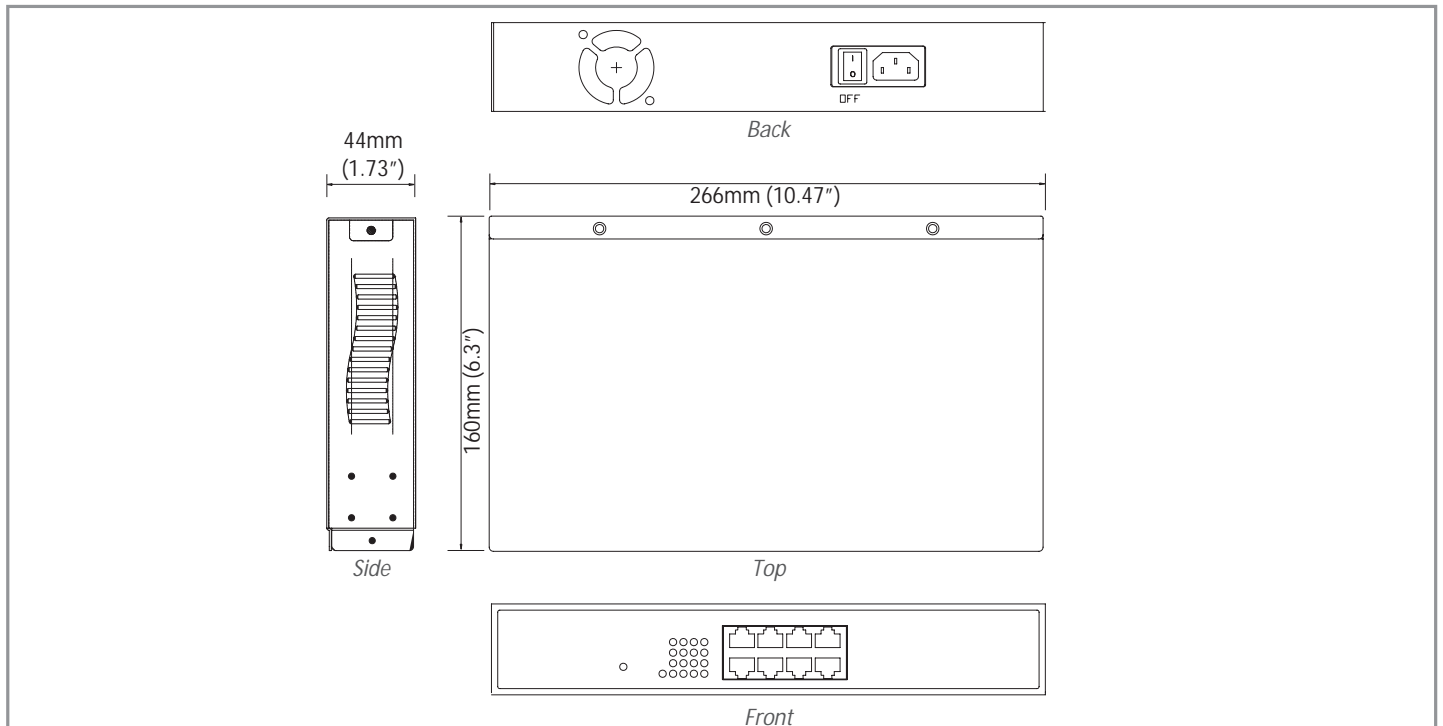

EX17016

Web-smart 16-port 10/100BASE-TX PoE Ethernet Switch



Overview

EtherWAN's EX17016 provides a 16-port switching platform supporting IEEE802.3af Power over Ethernet, high performance switching with features required for enterprise environments.

The EX17016 is equipped with 16 10/100BASE-TX PoE ports. The EX17016 is feature rich with full wire speed throughput, making the EX17016 Series a powerful network switch.

The IEEE802.3af PoE ports provide up to 15.4W/port with a total power budget of 246.4W, making the switch truly versatile for connecting with PoE Powered Devices (PD) with different bandwidth and power consumption requirements.

Users are able to access management features such as; IP configuration, QoS, VLANs, trunking and via web browser interfaces.

EtherWAN — "When Connectivity is Crucial."

Spotlight

- **Power over Ethernet**
 - Supports 16-port IEEE802.3af Power over Ethernet (PoE) and Power Sourcing Equipment (PSE)
- **Web-Managed Interface**
 - Comprehensive IP configuration, QoS, VLANs and trunking

Ordering Information

Model

EX17016	Web-smart 16-port 10/100BASE-TX PoE Ethernet Switch
---------	---

* Rack mounting kit included

Hardware Specifications

Technology

Standards

- IEEE802.3 10BASE-T
- IEEE802.3u 100BASE-TX
- IEEE802.3x full duplex and flow control
- IEEE 802.3af Power over Ethernet (PoE)

Forward and Filtering Rate

- 14,880pps for 10Mbps
- 148,810pps for 100Mbps

Packet Buffer Memory

- 1.5M bits

Processing Type

- Store-and-Forward
- Half-duplex back-pressure and IEEE802.3x full-duplex flow control

Address Table Size

- 4096 MAC addresses

Power

Input

- 100 to 240VAC, 50/60Hz

Power Consumption

- Device: Max. 13.5W (without PoE)
- PoE power budget: 246.4W Max.

PoE Power Output

- IEEE802.3af: up to 15.4W/port, 47 - 55VDC, 350mA Max

Mechanical

Casing

- Metal Case

Dimensions

- 440mm (W) x 220mm (D) x 44mm (H)
(17.32" (W) x 8.66" (D) x 1.73" (H))
- Standard 19" rack-mount size, one-unit-height

Dimensions

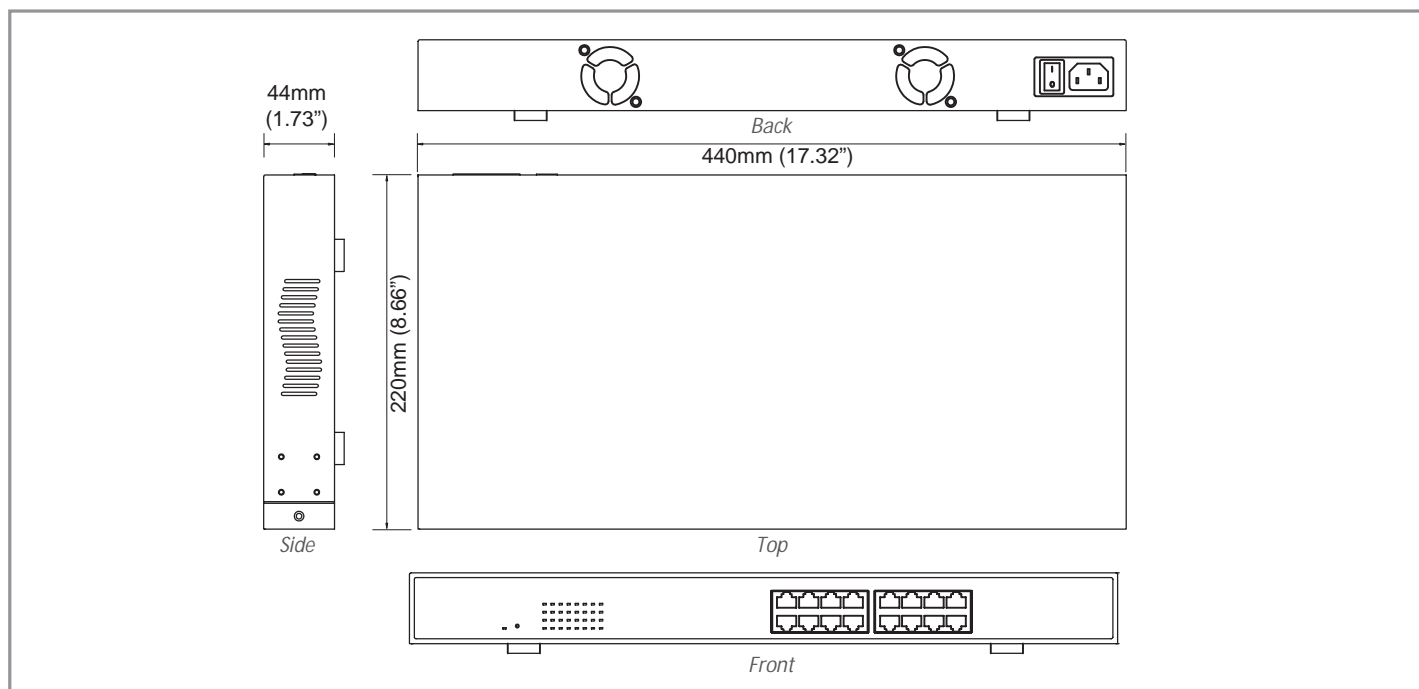

Weight

- 3.8Kg (8.37lbs.)

Installation

- Rack mounting

Interface

Ethernet Port

- 10/100BASE-TX: 16 PoE ports

LED Indicators

- Per Unit: Power Status
- Per port 10/100TX: Link/Activity
- Per port PoE: Act/status
- Per port Gigabit: Link/Act

Environment

Operating Temperature

- 0°C to 45°C (32°F to 113°F)

Storage Temperature

- -10°C to 70°C (14°F to 158°F)

Ambient Relative Humidity

- 10% to 95% (non-condensing)

Regulatory Approvals

ISO

- Manufactured in an ISO9001 facility

EMI

FCC Part 15, Class B

CE mark Class B

Safety

UL60950-1, EN60950-1, and IEC60950-1

EX17082

Web-Smart 8-port 10/100BASE-TX PoE (IEEE802.3at) and 2-port combo Gigabit SFP Ethernet Switch



Overview

EtherWAN's EX17082 provides a 10-port switching platform supporting IEEE802.3at Power over Ethernet, high performance switching with features required for small-business or enterprise environments where sustained connectivity is crucial.

The EX17082 is equipped with 8 10/100BASE-TX PoE ports, in combination with two Gigabit SFP ports. The EX17082 is feature rich with full wire speed throughput, QoS support, making the EX17082 Series a powerful network switch.

The IEEE802.3at PoE ports provide up to 30W/port with a total power budget of 246.4W, making the switch truly versatile for connecting with PoE Powered Devices (PD) with different bandwidth and power consumption requirements such as; outdoor PTZ dome cameras, wireless access points, and way-side communication devices.

Users are able to access management features such as; IP configuration, QoS, VLANs, trunking and via web browser interfaces.

EtherWAN — "When Connectivity is Crucial."

Spotlight

- **Power over Ethernet**
 - Supports 8-port IEEE802.3at Power over Ethernet (PoE) and Power Sourcing Equipment (PSE)
- **SFP Connectivity**
 - Built-in 2-port combo Gigabit SFP for either Gigabit copper or SFP connectivity
- **Web-Managed Interface**
 - Comprehensive IP configuration, QoS, VLANs and trunking

Ordering Information

Model

EX17082	Web-smart 8-port 10/100BASE-TX PoE (IEEE802.3at) and 2-port combo Gigabit SFP Ethernet Switch
---------	---

* Rack mounting kit included

Hardware Specifications

Technology

Standards

- IEEE802.3 10BASE-T
- IEEE802.3u 100BASE-TX/100BASE-FX
- IEEE802.3x Full duplex and flow control
- IEEE802.3ab 1000BASE-T
- IEEE802.3z 1000BASE-SX/LX
- IEEE802.1p QoS
- IEEE802.3at PoE

Forward and Filtering Rate

- 14,880pps for 10Mbps
- 148,810pps for 100Mbps
- 1,488,100pps for 1000Mbps

Packet Buffer Memory

- 2.75M bits

Processing Type

- Store-and-Forward
- Half-duplex back-pressure and IEEE802.3x full-duplex flow control

Address Table Size

- 4096 MAC addresses

Power

Input

- 100 to 240VAC, 50/60Hz

Power Consumption

- Device: Max. 9W (without PoE)
- PoE power budget: 246.4W Max.

PoE Power Output

- IEEE 802.3at: up to 30W/port, 50 - 57VDC, 600mA Max.

Mechanical

Casing

- Metal Case

Dimensions

- 440mm (W) x 220mm (D) x 44mm (H)
(17.32" (W) x 8.66" (D) x 1.73" (H))
- Standard 19" rack-mount size, one-unit-height

Weight

- 3.1Kg (6.83lbs.)

Installation

- Rack mounting

Interface

Ethernet Port

- 10/100BASE-TX: 8 PoE ports
- Gigabit: 2ports

LED Indicators

- Per Unit: Power Status
- Per Port 10/100TX: Link Activity
- Per port PoE: Act/status
- Per port Gigabit: Link/Activity, 1000M

Environment

Operating Temperature

- 0°C to 45°C (32°F to 113°F)

Storage Temperature

- -10°C to 70°C (14°F to 158°F)

Ambient Relative Humidity

- 10% to 95% (non-condensing)

Regulatory Approvals

ISO

- Manufactured in an ISO9001 facility

Emission Compliance

CE Mark Class A, FCC Part 15 ClassA

Dimensions

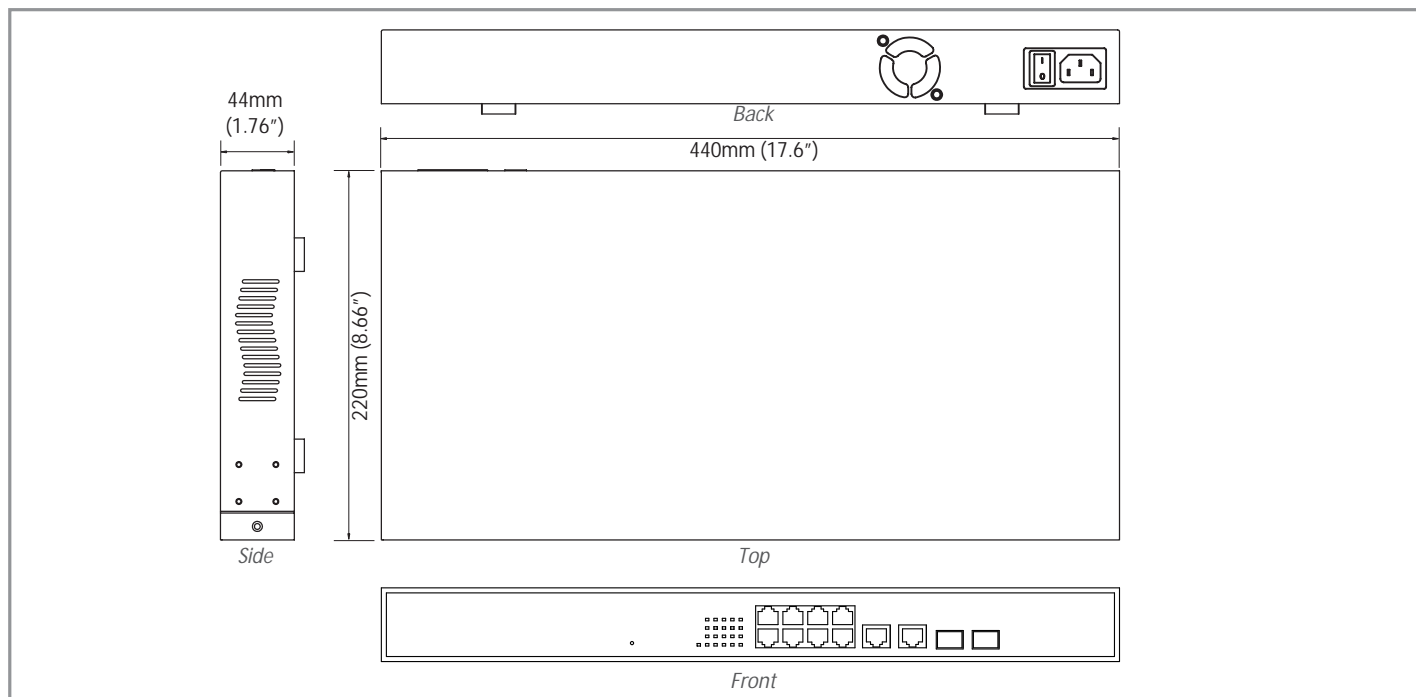

EX17162

Web-smart 16-port 10/100BASE-TX PoE and 2-port combo Gigabit SFP Ethernet Switch



Overview

EtherWAN's EX17162 provides an 18-port switching platform supporting IEEE802.3af Power over Ethernet, high performance switching with features required for small-business or enterprise environments where sustained connectivity is crucial.

The EX17162 is equipped with 16 10/100BASE-TX PoE ports, in combination with two Gigabit SFP ports. The EX17162 is feature rich with full wire speed throughput, QoS support, making the EX17162 Series a powerful network switch.

The IEEE802.3af PoE ports provide up to 15.4W/port with a total power budget of 260W, making the switch truly versatile for connecting with PoE Powered Devices (PD) with different bandwidth and power consumption.

Users are able to access management features such as IP configuration, QoS, VLANs, trunking and via web browser interfaces.

EtherWAN — "When Connectivity is Crucial."

Spotlight

• Power over Ethernet

- Supports 16-port IEEE802.3af Power over Ethernet (PoE) and Power Sourcing Equipment (PSE)

• SFP Connectivity

- Built-in 2-port combo Gigabit SFP for either Gigabit copper or SFP connectivity

• Web-Managed Interface

- Comprehensive IP configuration, QoS, VLANs and trunking

Hardware Specifications

Technology

Standards

- IEEE802.3 10BASE-T
- IEEE802.3u 100BASE-TX
- IEEE802.3ab 1000BASE-T
- IEEE802.3z 1000BASE-SX/1000BASE-LX
- IEEE802.3x Full duplex and flow control
- IEEE802.1p QoS
- IEEE802.3af Power over Ethernet (PoE)

Forward and Filtering Rate

- 14,880pps for 10Mbps
- 148,810pps for 100Mbps
- 1,488,100pps for 1000Mbps

Packet Buffer Memory

- 2.75M bits

Processing Type

- Store-and-Forward
- Half-duplex back-pressure and IEEE802.3x full-duplex flow control

Address Table Size

- 4096 MAC addresses

Power

Input

- 100 to 240VAC, 50/60Hz

Power Consumption

- Device: Max. 12W (without PoE)
- PoE power budget: 246.4W Max.

PoE Power Output

- IEEE802.3af: up to 15.4W/port, 47 - 55VDC, 350mA Max

Mechanical

Casing

- Metal Case

Dimensions

- 440mm (W) × 330mm (D) × 44mm (H)
(17.32" (W) x 13.2" (D) x 1.73" (H))
- Standard 19" rack-mount size, one-unit-height

Weight

- 4.3Kg (9.46lbs.)

Installation

- Rack mounting

Interface

Ethernet Port

- 10/100BASE-TX: 16 PoE ports
- Gigabit: 2 ports

LED Indicators

- Per Unit: Power Status
- Per Port 10/100TX: Link/Activity
- Per Port PoE: Act/status
- Per Port Gigabit: Link/Activity

Environment

Operating Temperature

- 0°C to 45°C (32°F to 113°F)

Storage Temperature

- -10°C to 70°C (14°F to 158°F)

Ambient Relative Humidity

- 10 to 90% (non-condensing)

Regulatory Approvals

ISO

- Manufactured in an ISO9001 facility

EMI

CE Mark Class A, FCC Part 15 ClassA

Safety

UL60950-1, EN60950-1, IEC60950-1

Dimensions

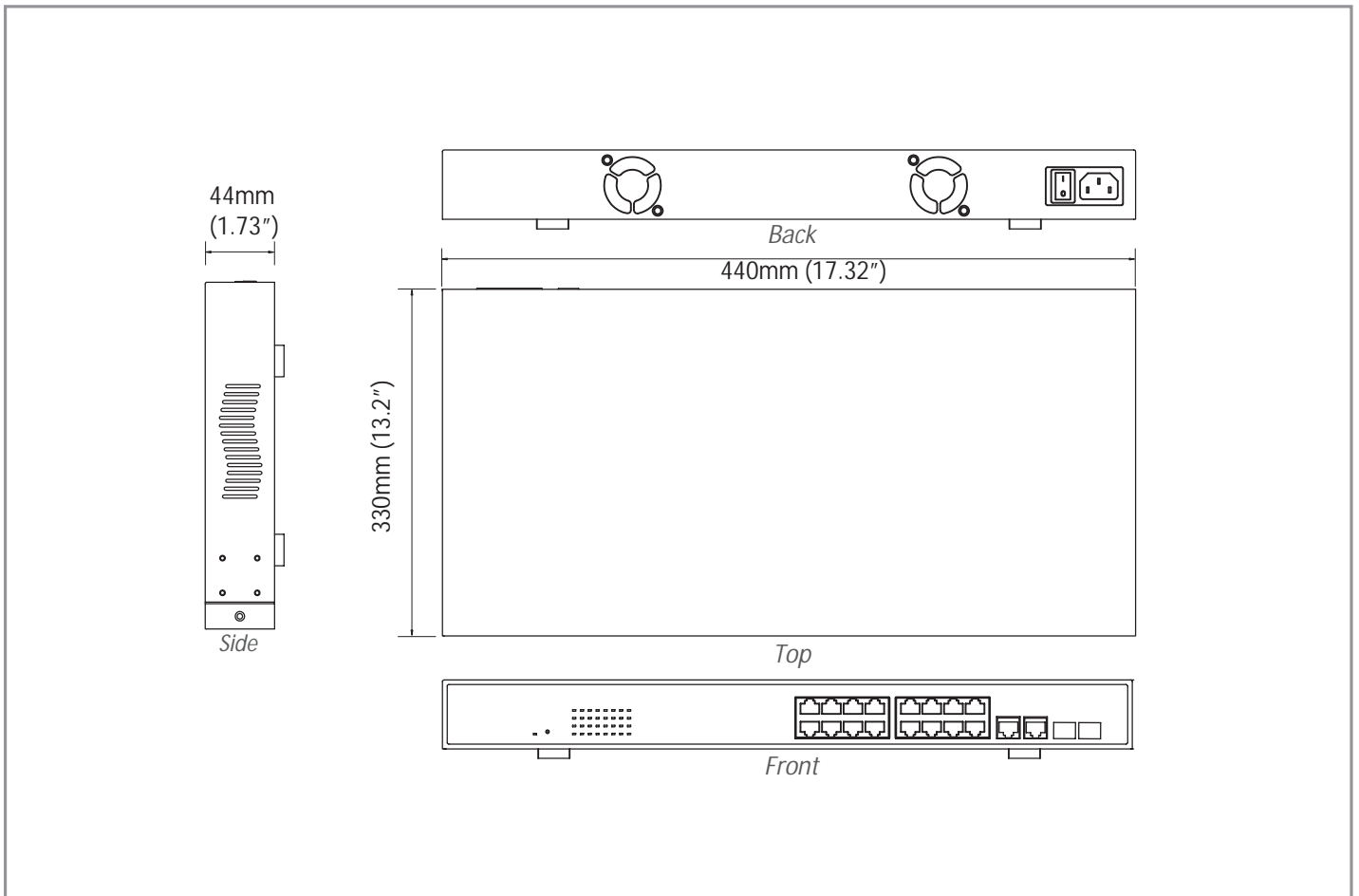

Ordering Information

Model

EX17162	Web-smart 16-port 10/100BASE-TX PoE and 2-port combo Gigabit SFP Ethernet Switch
---------	--

* Rack mounting kit included

EX17908

Web-smart 8-port 10/100/1000BASE-T PoE Ethernet Switch



Overview

EtherWAN's EX17908 provides an 8-port switching platform supporting IEEE802.3at Power over Ethernet, high performance switching with features required for small-business enterprise environments.

The EX17908 is equipped with 8 10/100/1000BASE-TX PoE ports. The EX17908 is feature-rich with full wire speed throughput, QoS support, making the EX17908 Series a powerful network switch.

The IEEE802.3at PoE ports provide up to 30W/port with a total power budget of 240W, making the switch truly versatile for connecting with PoE Powered Devices (PD) with different bandwidth and power consumption requirements such as; outdoor PTZ dome cameras, wireless access points, and way-side communication devices.

Users are able to access management features such as IP configuration, QoS, VLANs, trunking and via web browser interfaces.

Spotlight

• Power over Ethernet

- Supports IEEE802.3at Power over Ethernet (PoE) and Power Sourcing Equipment (PSE)
- PoE power output up to 30W/port, power budget up to 240W

• Web-Smart Switch

- PoE (Power status, Link status), System, IP configuration, Port-based VLAN, QoS Priority through the web browser interface.

• Easy to Install

- Internal universal PSU 100VAC - 240VAC, 50 - 60HZ

Ordering Information

Model

EX17908	Web-smart 8-port PoE 10/100/1000BASE-T Ethernet Switch
---------	--

Optional Accessories

KR-BK17	A black metal rack mounting kit consisting of two L-shaped brackets with pre-drilled holes for screws.	Rack mounting kit (black)
---------	--	---------------------------

Hardware Specifications

Technology

Standards

- IEEE802.3 10BASE-T
- IEEE802.3u 100BASE-TX/100BASE-FX
- IEEE802.3x Full duplex and flow control
- IEEE802.3ab 1000BASE-TX
- IEEE802.3z 1000BASE-SX/LX
- IEEE802.3af/at Power over Ethernet

Forward and Filtering Rate

- 14,880pps for 10Mbps
- 148,810pps for 100Mbps
- 1,488,100pps for 1000Mbps

Packet Buffer Memory

- 2M bits

Processing Type

- Store-and-Forward
- Half-duplex back-pressure and IEEE802.3x full-duplex flow control

Jumbo Frame

- 9.6K bytes

Address Table Size

- 8192 MAC addresses

Power

Input

- 100 to 240VAC, 50/60Hz

Power Consumption

- Device: Max. 8.8W (without PoE)
- PoE power budget: 240W Max.

PoE Power Output

- IEEE802.3at: up to 30W/port, 55VDC, 545mA Max.

Mechanical

Casing

- Metal Case

Dimensions

- 266mm (W) x 160mm (D) x 44mm (H)
(10.47" (W) x 6.30" (D) x 1.73" (H))

Weight

- 1.52Kg (3.35lbs.)

Installation

- Desktop, Rack Mounting

Interface

Ethernet Port

- 10/100/1000BASE-T: 8 ports (PoE)

LED Indicators

- Per Unit: Power Status
- Per Port: Link/Activity
- Per Port PoE: Act/status

Environment

Operating Temperature

- 0°C to 40°C (32°F to 104°F)

Storage Temperature

- -10°C to 70°C (14°F to 158°F)

Ambient Relative Humidity

- 10% to 95% (non-condensing)

Regulatory Approvals

ISO

- Manufactured in an ISO9001 facility

Emission Compliance

CE Mark Class A

FCC Part 15 ClassA

Dimensions

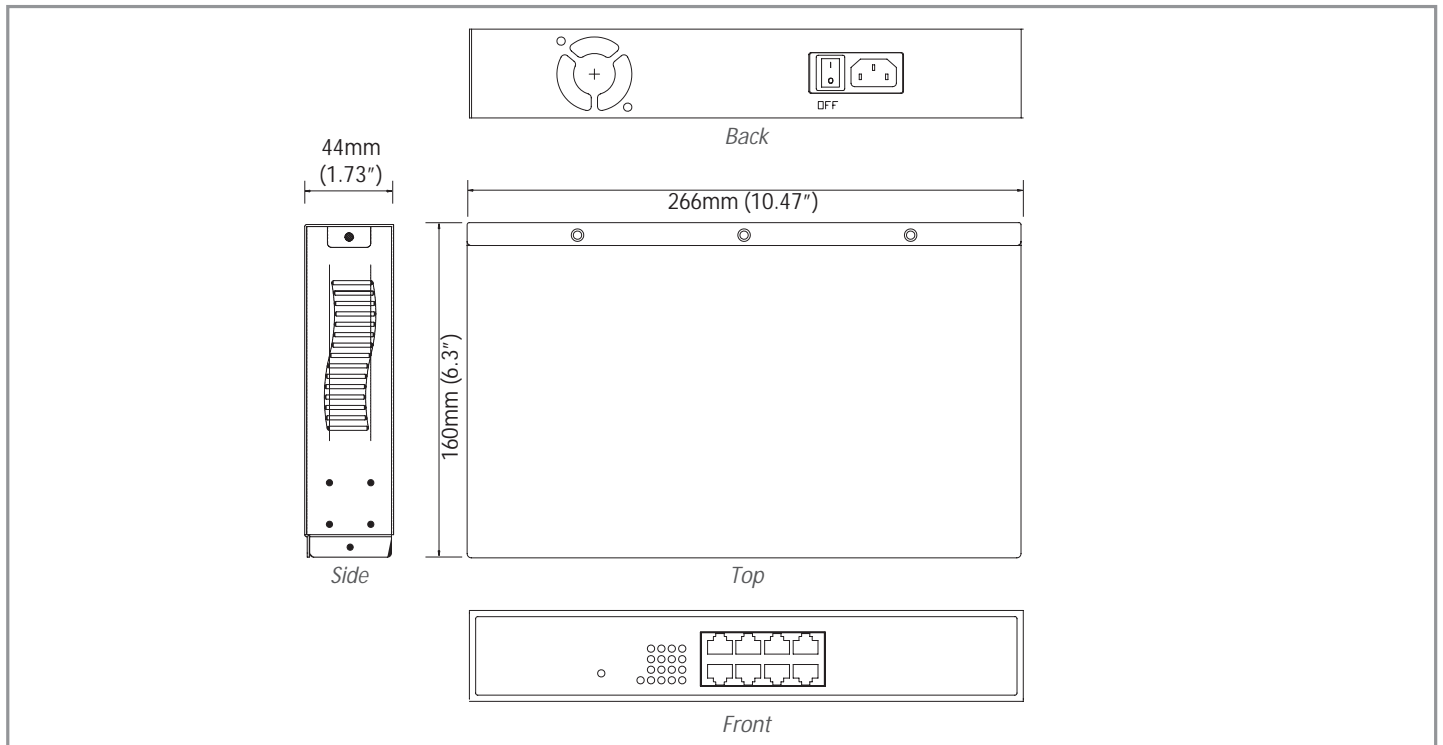

EX17162A

Unmanaged 16-port 10/100BASE-TX PoE and 2-port combo Gigabit SFP Ethernet Switch



Overview

EtherWAN's 17162A provides an 18-port switching platform supporting IEEE802.3af Power over Ethernet, high performance switching with features required for small-business or enterprise environments where sustained connectivity is crucial.

The EX17162A is equipped with 16 10/100BASE-TX PoE ports, in combination with two Gigabit SFP combo ports. The EX17162A is feature rich with full wire speed throughput, making the EX17162A Series a powerful network switch.

The IEEE802.3af PoE ports provide up to 15.4W/port with a total power budget of 260W, making the switch truly versatile for connecting with PoE Powered Devices (PD) with different bandwidth and power consumption requirements.

EtherWAN — "When Connectivity is Crucial."

Spotlight

• Power over Ethernet

- Supports 16-port IEEE802.3af Power over Ethernet (PoE) and Power Sourcing Equipment (PSE)

• SFP Connectivity

- Built-in 2-port combo Gigabit SFP for either Gigabit copper or SFP connectivity

• Easy to Install

- Supports rack mounting
- Plug-and-play operation

Hardware Specifications

Technology

Standards

- IEEE802.3 10BASE-T
- IEEE802.3u 100BASE-TX
- IEEE802.3ab 1000BASE-T
- IEEE802.3z 1000BASE-SX/1000BASE-LX
- IEEE802.3x full duplex and flow control
- IEEE802.3af Power over Ethernet

Forward and Filtering Rate

- 14,880pps for 10Mbps
- 148,810pps for 100Mbps
- 1,488,100pps for 1000Mbps

Packet Buffer Memory

- 2.75M bits

Processing Type

- Store-and-Forward
- Auto Negotiation
- Half-duplex back-pressure and IEEE802.3x full-duplex flow control
- Auto MDI/MDIX

Address Table Size

- 4096 MAC addresses

Power

Input

- 100 to 240VAC, 50/60Hz

Power Consumption

- Device: Max. 12W (without PoE)
- PoE power budget: 246.4W Max.

PoE Power Output

- IEEE802.3af: up to 15.4W/port, 47 - 55VDC, 350mA Max

Mechanical

Casing

- Metal Case

Dimensions

- 440mm (W) × 330mm (D) × 44mm (H)
(17.32" (W) × 13.2" (D) × 1.76" (H))
- Standard 19" rack-mount size, one-unit-height

Weight

- 4.3 kg (9.46lbs.)

Installation

- Rack mounting

Interface

Ethernet Port

- 10/100BASE-TX: 16 PoE ports
- Gigabit: 2 ports

LED Indicators

- Per Unit: Power Status
- Per Port 10/100TX: Link/Activity
- Per port PoE: Act/status
- Per Port Gigabit: Link/Activity

Environment

Operating Temperature

- 0°C to 45°C (32°F to 113°F)

Storage Temperature

- -10°C to 70°C (14°F to 158°F)

Ambient Relative Humidity

- 10 to 90% (non-condensing)

Regulatory Approvals

ISO

- Manufactured in an ISO9001 facility

EMI

CE Mark Class A, FCC Part 15 ClassA

Safety

UL60950-1, EN60950-1, IEC60950-1

Dimensions

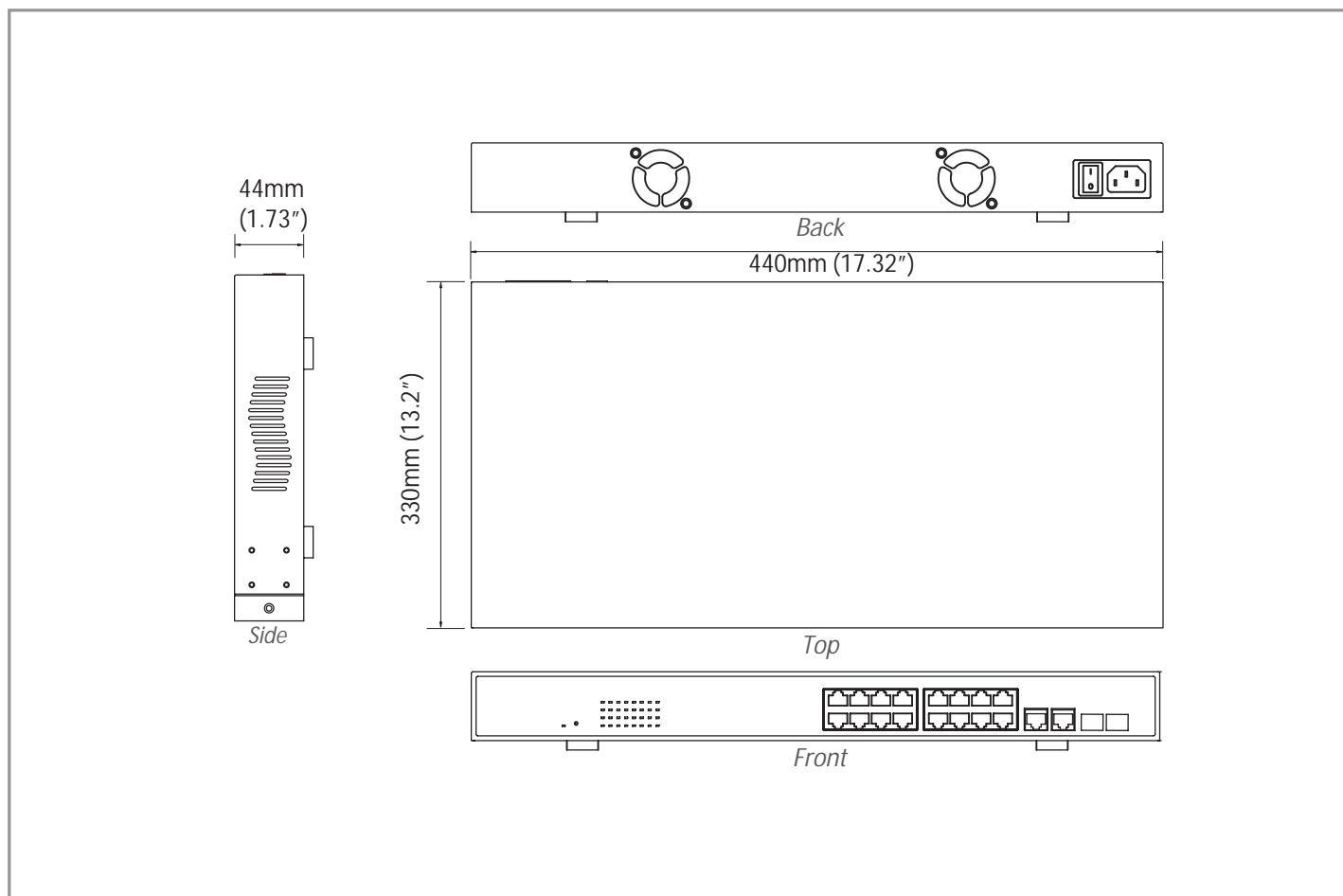

Ordering Information

Model

EX17162A	Unmanaged 16-port 10/100BASE-TX PoE and 2-port combo Gigabit SFP Ethernet Switch
----------	--

* Rack mounting kit included

EX17044A

Unmanaged 8-port 10/100BASE-TX (4 x PoE) Ethernet Switch



Overview

EtherWAN's EX17044A Series provides a 8-port switching platform supporting IEEE802.3af Power over Ethernet, high performance switching with features required for enterprise environments.

The EX17044A Series is equipped with 4 10/100BASE-TX PoE ports. The EX17044A is feature-rich with full wire speed throughput, making the EX17044A Series a powerful network switch.

The IEEE802.3af PoE ports provide up to 15.4W/port with a total power budget of 59W, making the switch truly versatile for connecting with PoE Powered Devices (PD) with different bandwidth and power consumption requirements.

EtherWAN — "When Connectivity is Crucial."

Spotlight

• Power over Ethernet

- Supports 4-port IEEE802.3af Power over Ethernet (PoE) and Power Sourcing Equipment (PSE)

• Easy to Install

- Plug-and-play operation

Ordering Information

Model

EX17044A	Unmanaged 8-port 10/100BASE-TX (4 x PoE) Ethernet Switch
----------	--

Optional Accessories

KR-BK17	A black metal rack mounting kit consisting of two L-shaped brackets with pre-drilled holes for screws.	Rack mounting kit (black)
---------	--	---------------------------

Hardware Specifications

Technology

Standards

- IEEE802.3 10BASE-T
- IEEE802.3u 100BASE-TX/100BASE-FX
- IEEE802.3x Full duplex and flow control
- IEEE802.3af Power over Ethernet

Forward and Filtering Rate

- 14,880pps for 10Mbps
- 148,810pps for 100Mbps

Packet Buffer Memory

- 512K bits

Processing Type

- Store-and-Forward
- Half-duplex back-pressure and IEEE802.3x full-duplex flow control

Address Table Size

- 1024 MAC addresses

Power

Input

- 100 to 240VAC, 50/60Hz

Power Consumption

- Device: 6W Max. (without PoE)

PoE Power Budget

- 59W Max.

PoE Power Output

- IEEE802.3af: up to 15.4W/port, 47 - 55VDC, 350mA Max.

Mechanical

Casing

- Metal Case

Dimensions

- 266mm (W) x 160mm (D) x 44mm (H)
(10.47" (W) x 6.30" (D) x 1.73" (H))
- Standard 19" rack-mount size, one-unit-height

Weight

- 1.4Kg (3.08lbs.)

Installation

- Desktop, Rack mounting

Interface

Ethernet Port

- 10/100BASE-TX: 8 PoE ports (4 x PoE)

LED Indicators

- Per Unit: Power
- Per Port: Link/Activity and PoE Act/status

Environment

Operating Temperature

- 0°C to 45°C (32°F to 113°F)

Storage Temperature

- -10°C to 70°C (14°F to 158°F)

Ambient Relative Humidity

- 10% to 95% (non-condensing)

Regulatory Approvals

ISO

- Manufactured in an ISO9001 facility

EMI

CE Mark Class A, FCC Part 15 ClassA

Safety

UL60950-1

Dimensions

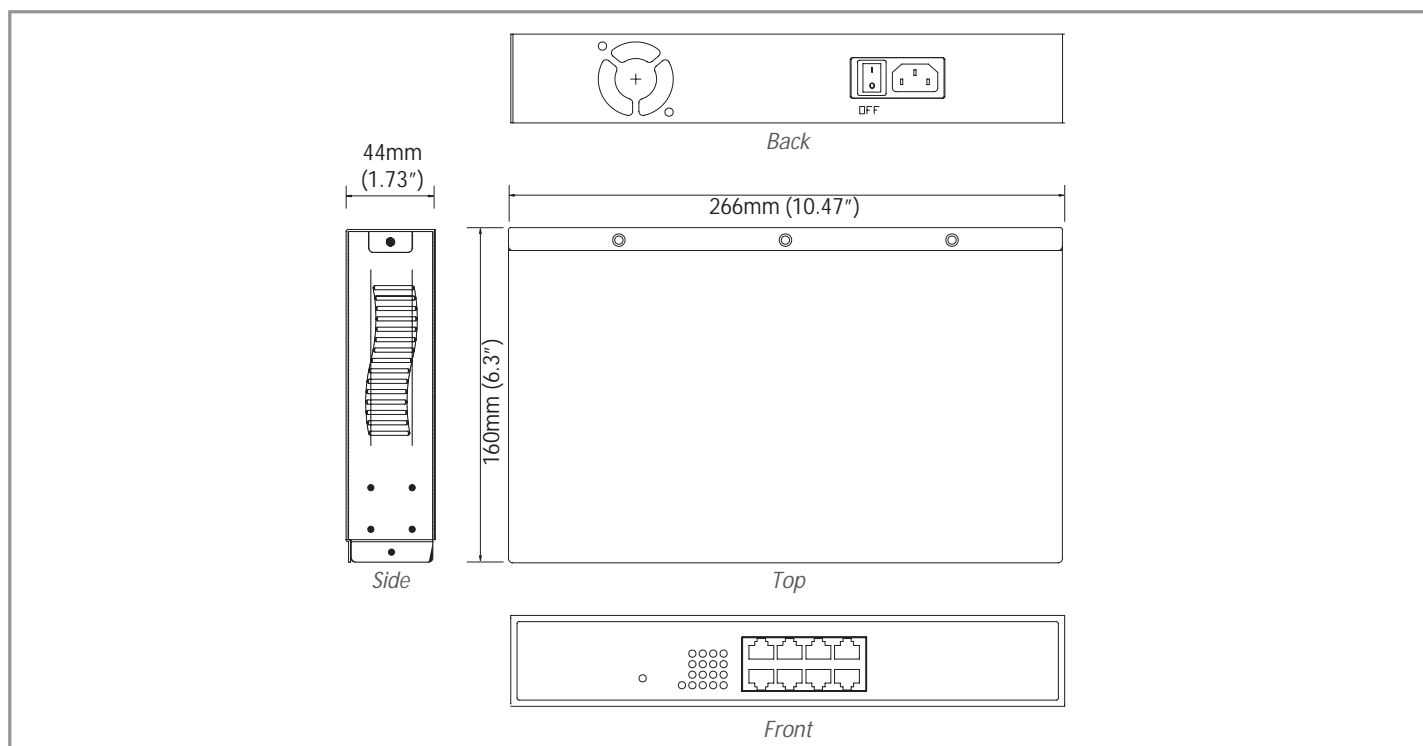

EX17016A

Unmanaged 16-port 10/100BASE-TX PoE Ethernet Switch



Overview

EtherWAN's 17016A provides a 16-port switching platform supporting IEEE802.3af Power over Ethernet, high performance switching with features required for small-business or enterprise environments where sustained connectivity is crucial.

The EX17016A is equipped with 16 10/100BASE-TX PoE ports. The EX17016A is feature rich full with wire speed throughput, making the EX17016A Series a powerful network switch.

The IEEE802.3af PoE ports provide up to 15.4W/port with a total power budget of 246.4W, making the switch truly versatile for connecting with PoE Powered Devices (PD) with different bandwidth and power consumption requirements.

Spotlight

• Power over Ethernet

- Supports 16-port IEEE802.3af Power over Ethernet (PoE) and Power Sourcing Equipment (PSE)

• Easy to Install

- Supports rack mounting
- Plug-and-play operation

Ordering Information

Model

EX17016A	Unmanaged 16-port 10/100BASE Fast Ethernet PoE Ethernet Switch
----------	--

* Rack mounting kit included

Hardware Specifications

Technology

Standards

- IEEE802.3 10BASE-T
- IEEE802.3u 100BASE-TX/100BASE-FX
- IEEE802.3x Full duplex and flow control
- IEEE802.3af Power over Ethernet

Forward and Filtering Rate

- 14,880pps for 10Mbps
- 148,810pps for 100Mbps

Packet Buffer Memory

- 1.5M bits

Processing Type

- Store-and-Forward
- Half-duplex back-pressure and IEEE802.3x full-duplex flow control

Address Table Size

- 4096 MAC addresses

Power

Input

- 100 to 240VAC, 50/60Hz

Power Consumption

- 260W Max.

Power Consumption

- Device: Max. 13.5W (without PoE)
- PoE power budget: 246.4W Max.

PoE Power Output

- IEEE802.3af: up to 15.4W/port, 47 - 55VDC, 350mA Max

Mechanical

Casing

- Metal Case

Dimensions

- 440mm (W) x 220mm (D) x 44mm (H)
(17.32" (W) x 8.66" (D) x 1.73" (H))
- Standard 19" rack-mount size, one-unit-height

Weight

- 3.8Kg (8.37lbs.)

Installation

- Rack mounting

Interface

Ethernet Port

- 10/100BASE-TX: 16 PoE ports

LED Indicators

- Per Unit: Power Status
- Per Port 10/100TX: Link/Activity
- Per port PoE: Act/status

Environment

Operating Temperature

- 0°C to 45°C (32°F to 113°F)

Storage Temperature

- -10°C to 70°C (14°F to 158°F)

Ambient Relative Humidity

- 10% to 95% (non-condensing)

Regulatory Approvals

ISO

- Manufactured in an ISO9001 facility

EMI

CE Mark Class B, FCC Part 15, Class B

Safety

UL60950-1, EN60950-1, IEC60950-1

Dimensions

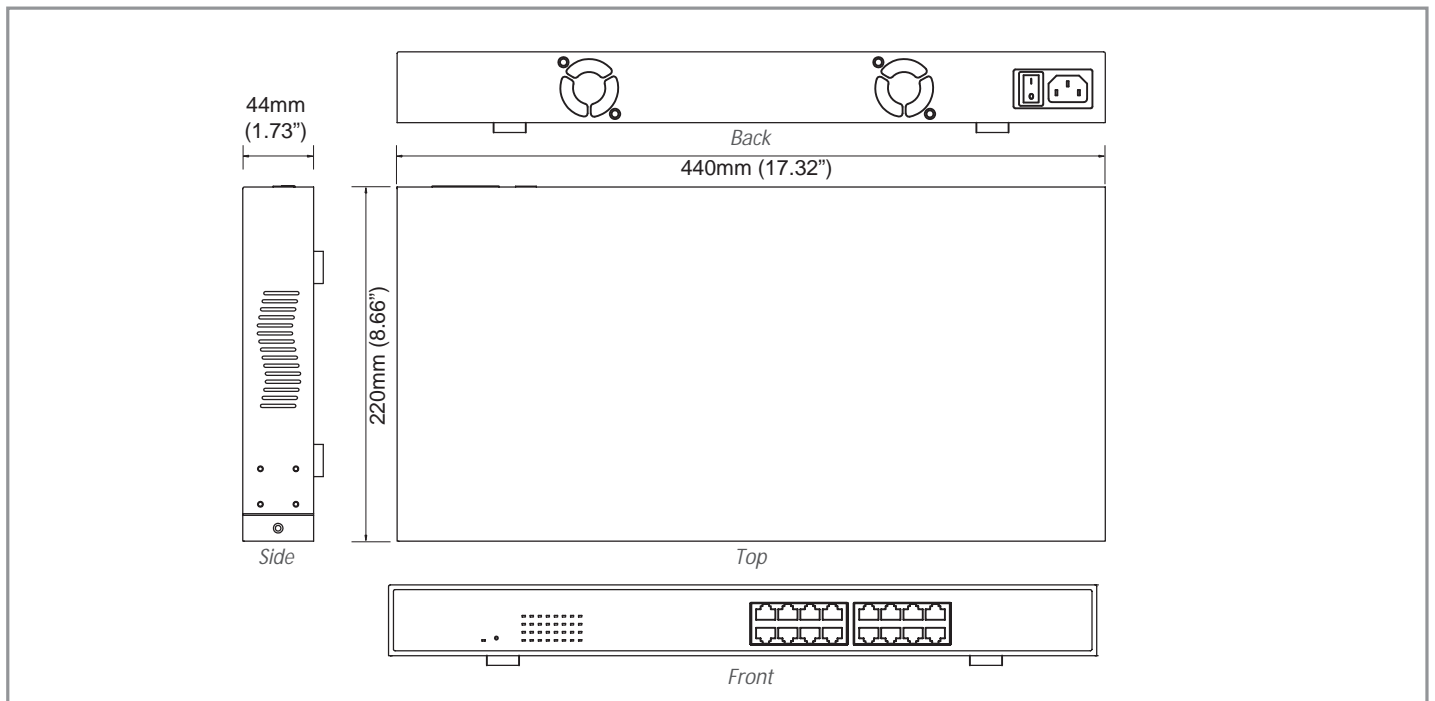

EX17082A

Unmanaged 8-port PoE (IEEE802.3at) 10/100BASE-TX and 2-port combo Gigabit SFP Ethernet Switch



Overview

EtherWAN's EX17082A provides a 10-port switching platform supporting IEEE802.3at Power over Ethernet, high performance switching with robust features required for small-business or enterprise environments where sustained connectivity is crucial.

The EX17082A is equipped with 8 10/100BASE-TX PoE ports, in combination with two Gigabit SFP ports. The EX17082A is feature rich with full wire speed throughput, making the EX17082A Series a powerful network switch.

The IEEE802.3at PoE ports provide up to 30W/port with a total power budget of 246.4W, making the switch truly versatile for connecting with PoE Powered Devices (PD) with different bandwidth and power consumption requirements such as; outdoor PTZ dome cameras, wireless access points, and way-side communication devices.

EtherWAN — "When Connectivity is Crucial."

Spotlight

- **Power over Ethernet**
 - Supports 8-port IEEE802.3at Power over Ethernet (PoE) and Power Sourcing Equipment (PSE)
- **SFP Connectivity**
 - Built-in 2-port combo Gigabit SFP for either Gigabit copper or SFP connectivity

Ordering Information

Model

EX17082A	Unmanaged 8-port PoE (IEEE802.3at) 10/100BASE-TX and 2-port combo Gigabit SFP Ethernet Switch
----------	---

* Rack mounting kit included

Hardware Specifications

Technology

Standards

- IEEE802.3 10BASE-T
- IEEE802.3u 100BASE-TX/100BASE-FX
- IEEE802.3x full duplex and flow control
- IEEE802.3ab 1000BASE-TX
- IEEE802.3z 1000BASE-SX/LX
- IEEE802.3af/at Power over Ethernet

Forward and Filtering Rate

- 14,880pps for 10Mbps
- 148,810pps for 100Mbps
- 1,488,100pps for 1000Mbps

Packet Buffer Memory

- 2.75M bits

Processing Type

- Store-and-Forward
- Half-duplex back-pressure and IEEE802.3x full-duplex flow control

Address Table Size

- 4096 MAC addresses

Power

Input

- 100 to 240VAC, 50/60Hz Internal Universal PSU

Power Consumption

- 260W Max.

Mechanical

Casing

- Metal Case

Dimensions

- 440mm (W) x 220mm (D) x 44mm (H)
(17.6" (W) x 8.8" (D) x 1.76" (H))
- Standard 19" rack-mount size, one-unit-height

Weight

- 3.1Kg (6.83lbs.)

Installation

- Rack mounting

Interface

Ethernet Port

- 10/100BASE-TX: 8 PoE ports
- Gigabit: 2ports

LED Indicators

- Per Unit: Power Status
- Per Port 10/100TX and 100FX: Link/Activity
- Per Port PoE: Act/status

Environment

Operating Temperature

- 0°C to 45°C (32°F to 113°F)

Storage Temperature

- -10°C to 70°C (14°F to 158°F)

Ambient Relative Humidity

- 10% to 90% (non-condensing)

Regulatory Approvals

ISO

- Manufactured in an ISO9001 facility

EMI

CE Mark Class A, FCC Part 15 ClassA

Dimensions

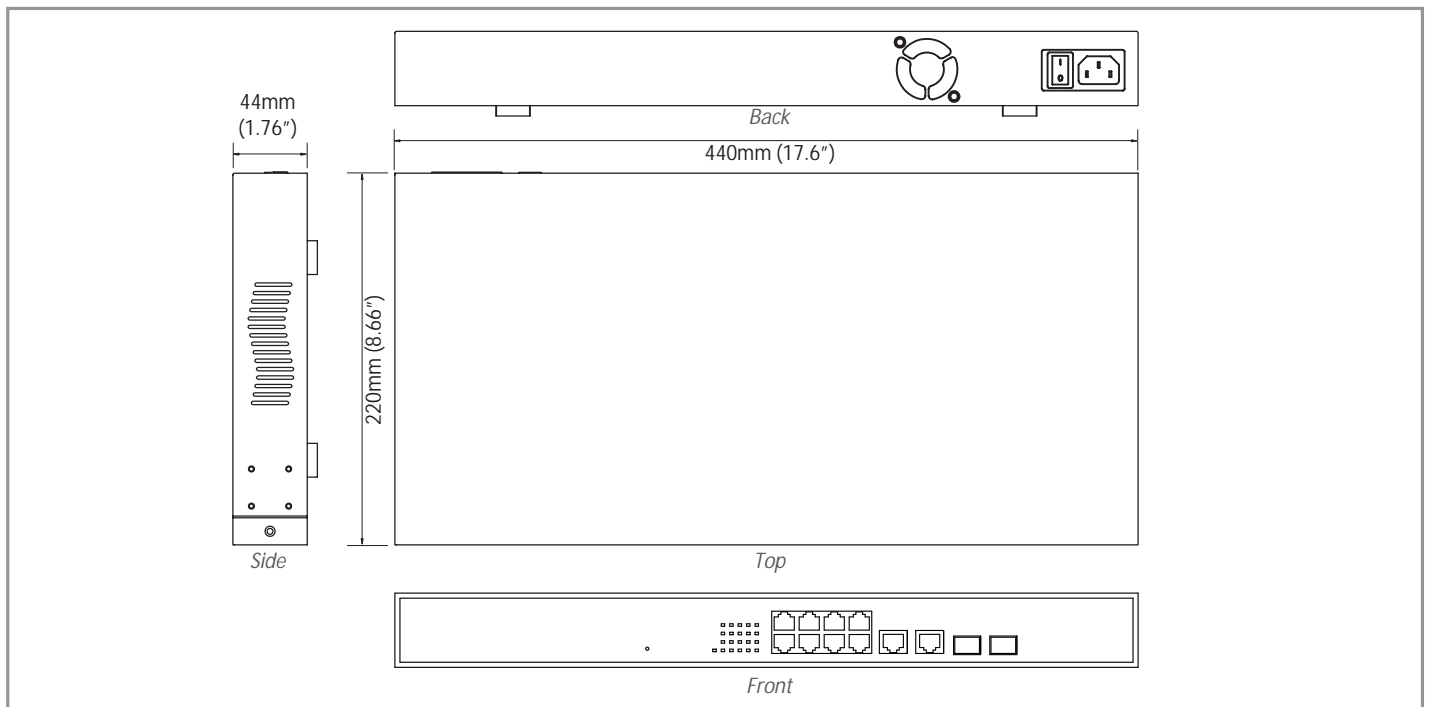

EX17908A

Unmanaged 8-port 10/100/1000BASE-T PoE Ethernet Switch



Overview

EtherWAN's EX17908A provides an 8-port switching platform supporting IEEE802.3at Power over Ethernet, high performance switching with features required for enterprise environments.

The EX17908A is equipped with 8 10/100/1000BASE-TX PoE ports. The EX17908A is feature-rich with full wire speed throughput, making the EX17908A Series a powerful network switch.

The IEEE802.3at PoE ports provide up to 30W/port with a total power budget of 240W, making the switch truly versatile for connecting with PoE Powered Devices (PD) with different bandwidth and power consumption requirements such as outdoor PTZ dome cameras, wireless access points, and way-side communication devices.

EtherWAN — "When Connectivity is Crucial."

Spotlight

• Power over Ethernet

- Supports IEEE802.3at Power over Ethernet (PoE) and Power Sourcing Equipment (PSE)
- PoE power output up to 30W/port, power budget up to 240W

• Easy to Install

- Internal universal PSU 100VAC - 240VAC, 50 - 60HZ

Ordering Information

Model

EX17908A	Unmanaged 8-port PoE 10/100/1000BASE-T Ethernet Switch
----------	--

Optional Accessories

KR-BK17	A black metal rack mounting kit consisting of two L-shaped brackets with pre-drilled holes for screws.	Rack mounting kit (black)
---------	--	---------------------------

Hardware Specifications

Technology

Standards

- IEEE802.3 10BASE-T
- IEEE802.3u 100BASE-TX/100BASE-FX
- IEEE802.3x Full duplex and flow control
- IEEE802.3ab 1000BASE-TX
- IEEE802.3z 1000BASE-SX/LX
- IEEE802.3af/at Power over Ethernet

Forward and Filtering Rate

- 14,880pps for 10Mbps
- 148,810pps for 100Mbps
- 1,488,100pps for 100Mbps

Packet Buffer Memory

- 2M bits

Processing Type

- Store-and-Forward
- Half-duplex back-pressure and IEEE802.3x full-duplex flow control

Jumbo Frame

- 9.6K bytes

Address Table Size

- 8192 MAC addresses

Power

Input

- 100 to 240VAC, 50/60Hz

Power Consumption

- Device: Max. 8.8W (without PoE)
- PoE power budget: 240W Max.

PoE Power Output

- IEEE802.3at: up to 30W/port, 55VDC, 545mA Max.

Mechanical

Casing

- Metal Case

Dimensions

- 266mm (W) x 160mm (D) x 44mm (H)
(10.47" (W) x 6.30" (D) x 1.73" (H))

Weight

- 1.52Kg (3.35lbs.)

Installation

- Desktop, Rack Mounting

Interface

Ethernet Port

- 10/100/1000BASE-T: 8 ports (PoE)

LED Indicators

- Per Unit: Power Status
- Per Port: Link/Activity, PoE Act/status

Environment

Operating Temperature

- 0°C to 40°C (32°F to 104°F)

Storage Temperature

- -10°C to 70°C (14°F to 158°F)

Ambient Relative Humidity

- 10% to 95% (non-condensing)

Regulatory Approvals

ISO

- Manufactured in an ISO9001 facility

Emission Compliance

CE Mark Class A, FCC Part 15B ClassA

Dimensions

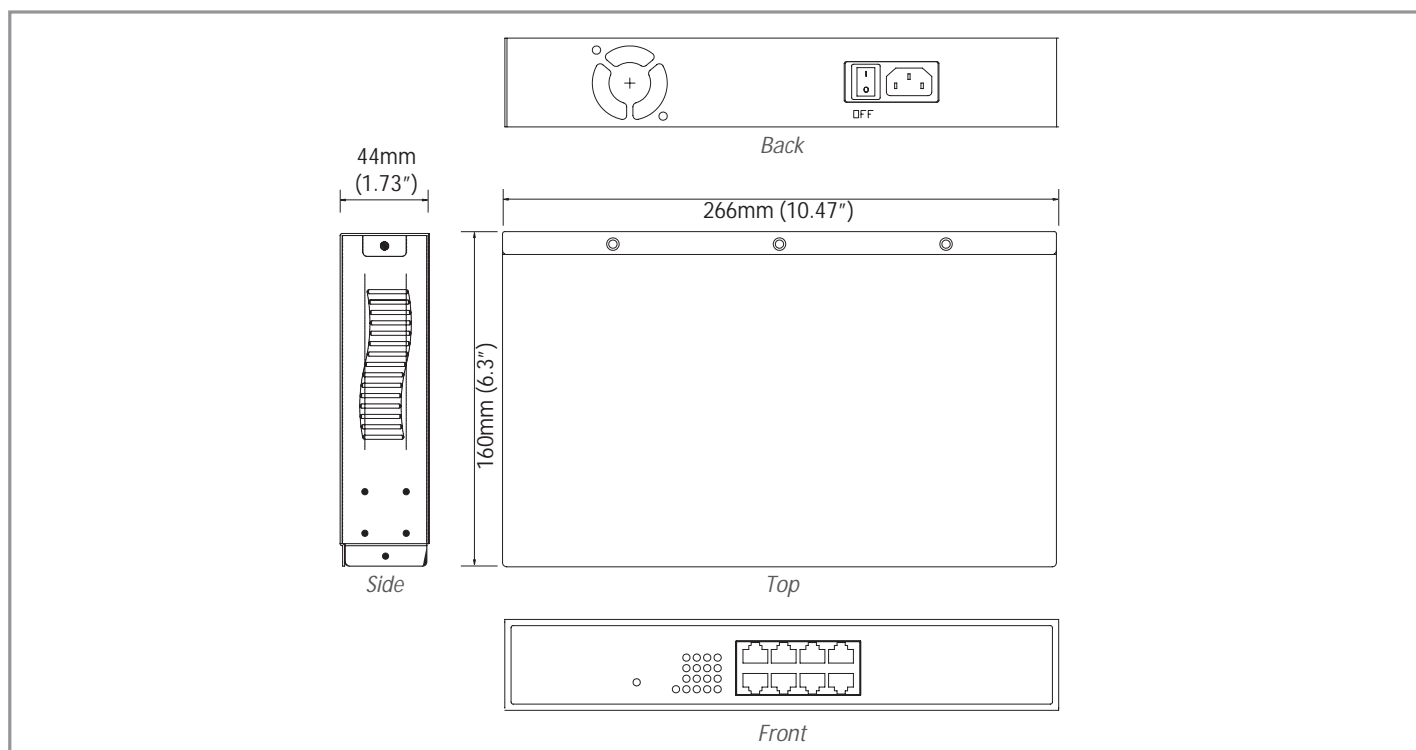

EX17008A

Unmanaged 8-port 10/100BASE-TX PoE Ethernet Switch



Overview

EtherWAN's EX17008A provides a 8-port switching platform supporting IEEE802.3af Power over Ethernet, high performance switching with features required for enterprise environments.

The EX17008A is equipped with 8 10/100BASE-TX PoE ports. The EX17008A is feature rich with full wire speed throughput, making the EX17008A Series a powerful network switch.

The IEEE802.3af PoE ports provide up to 15.4W/port with a total power budget of 123.2W, making the switch truly versatile for connecting with PoE Powered Devices (PD) with different bandwidth and power consumption requirements.

EtherWAN — "When Connectivity is Crucial."

Spotlight

- **Power over Ethernet**
 - Supports 8-port IEEE802.3af Power over Ethernet (PoE) and Power Sourcing Equipment (PSE)
- **Easy to Install**
 - Plug-and-play operation

Ordering Information

Model

EX17008A	Unmanaged 8-port 10/100BASE-TX PoE Ethernet Switch
----------	--

Optional Accessories

KR-BK17	A black metal rack mounting kit consisting of two L-shaped brackets with pre-drilled holes for screws.	Rack mounting kit (black)
---------	--	---------------------------

Hardware Specifications

Technology

Standards

- IEEE802.3 10BASE-T
- IEEE802.3u 100BASE-TX/100BASE-FX
- IEEE802.3x, Full duplex and flow control
- IEEE802.3af, Power over Ethernet

Forward and Filtering Rate

- 14,880pps for 10Mbps
- 148,810pps for 100Mbps

Packet Buffer Memory

- 512K bits

Processing Type

- Store-and-Forward
- Auto Negotiation
- Half-duplex back-pressure and IEEE802.3x full-duplex flow control
- Auto MDI/MDIX

Address Table Size

- 1024 MAC addresses

Power

Input

- 100 to 240VAC, 50/60Hz

Power Consumption

- Device: Max. 8.8W (without PoE)
- PoE power budget: 123.2W Max.

PoE Power Output

- IEEE802.3af: up to 15.4W/port, 47 - 55VDC, 350mA Max..

Mechanical

Casing

- Metal Case

Dimensions

Dimensions

- 266mm (W) x 160mm (D) x 44mm (H)
(10.47" (W) x 6.30" (D) x 1.73" (H))

Weight

- 1.4Kg (3.08lbs.)

Installation

- Desktop, Rack Mounting

Interface

Ethernet Port

- 10/100BASE-TX: 8 PoE ports

LED Indicators

- Per Unit: Power Status
- Per Port: Link/Activity, PoE Act/status

Environment

Operating Temperature

- 0°C to 45°C (32°F to 113°F)

Storage Temperature

- -10°C to 70°C (14°F to 158°F)

Ambient Relative Humidity

- 10% to 95% (non-condensing)

Regulatory Approvals

ISO

- Manufactured in an ISO9001 facility

Emission Compliance

FCC Part 15, Class B

CE mark Class B

Safety

UL60950-1, EN60950-1, IEC60950-1

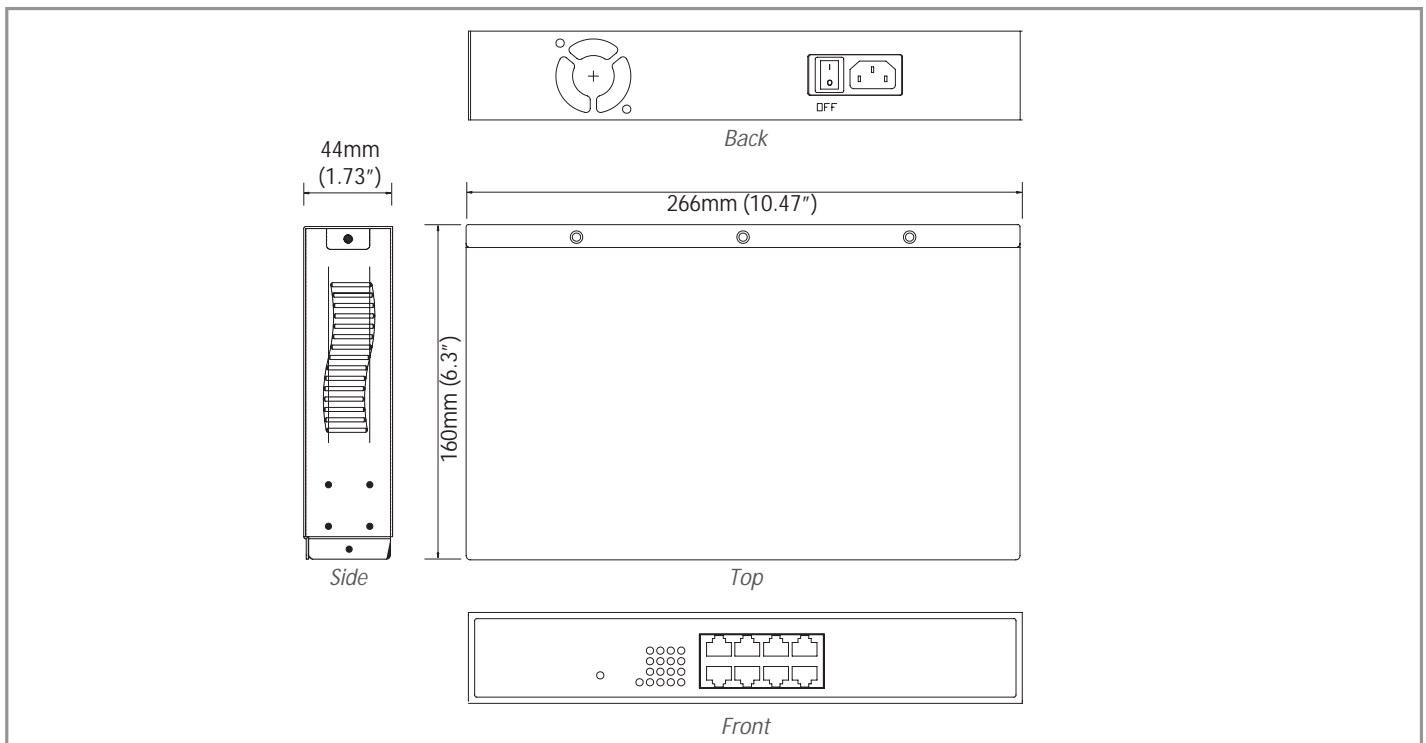

EX16916 Series

Unmanaged 16-port Gigabit Ethernet Switch



Overview

The EX16916 Series is equipped with sixteen Gigabit Ethernet ports and feature rich with 9K Jumbo Frame support, full wire speed Gigabit throughput, QoS support and eco-friendly IEEE802.3az EEE (Energy Efficient Ethernet) compliant, making the EX16916 Series a powerful yet energy efficient network switch.

EtherWAN – "When Connectivity is Crucial."

Spotlight

- **Jumbo Frame Support**
 - Up to 9K bytes
- **High Reliability**
 - Fanless design
 - No moving parts
- **Eco-friendly support**
 - IEEE802.3az EEE (Energy Efficient Ethernet) allow less consumption during periods of low data activity
- **QoS**
 - Traffic classification based on IEEE802.1p CoS

Ordering Information

Model

EX16916	Unmanaged 16-port 10/100/1000BASE-T Gigabit Ethernet Switch
---------	---

Hardware Specifications

Technology

Standards

- IEEE802.3 10BASE-T
- IEEE802.3u 100BASE-TX/100BASE-FX
- IEEE802.3ab 1000BASE-T
- IEEE802.1x, Full duplex flow control
- IEEE802.1az Energy Efficient Ethernet
- IEEE802.1p Quality of Service (QoS)

Forward and Filtering Rate

- 14,880pps for 10Mbps
- 148,810pps for 100Mbps
- 1,488,100pps for 1000Mbps

Packet Buffer Memory

- 256KB

Processing Type

- Store-and-Forward
- Auto Negotiation
- Half-duplex back-pressure and IEEE802.3x full-duplex flow control
- Auto MDI/MDIX

Jumbo Frame

- 9K bytes

Address Table Size

- 8K MAC addresses

Power

Input Voltage

- 100 to 240VAC

Power Consumption

- 8.1W Max. 0.85A.

Mechanical

Casing

- Metal case
- IP30

Dimensions

- 42mm (H) x 216mm (W) x 133mm (D)
(1.68" (H) x 8.64" (W) x 5.32" (D))

Weight

- 0.9Kg (1.98lbs.)

Installation

- Rack-mount (rack mounting kit included)

Interface

Ethernet Port

- 10/100/1000BASE-T: 16 ports

LED Indicators

- Per Unit: Power (Green)
- Per Port: Link & Activity (Green)

Environment

Operating Temperature

- 0°C to 50°C (32°F to 122°F)

Storage Temperature

- -40°C to 70°C (-40°F to 158°F)

Ambient Relative Humidity

- 10% to 95% (non-condensing)

Regulatory Approvals

ISO

- Manufactured in an ISO9001 facility

EMI

FCC Class B

CE Class B

LVD EN60950-1

Dimensions

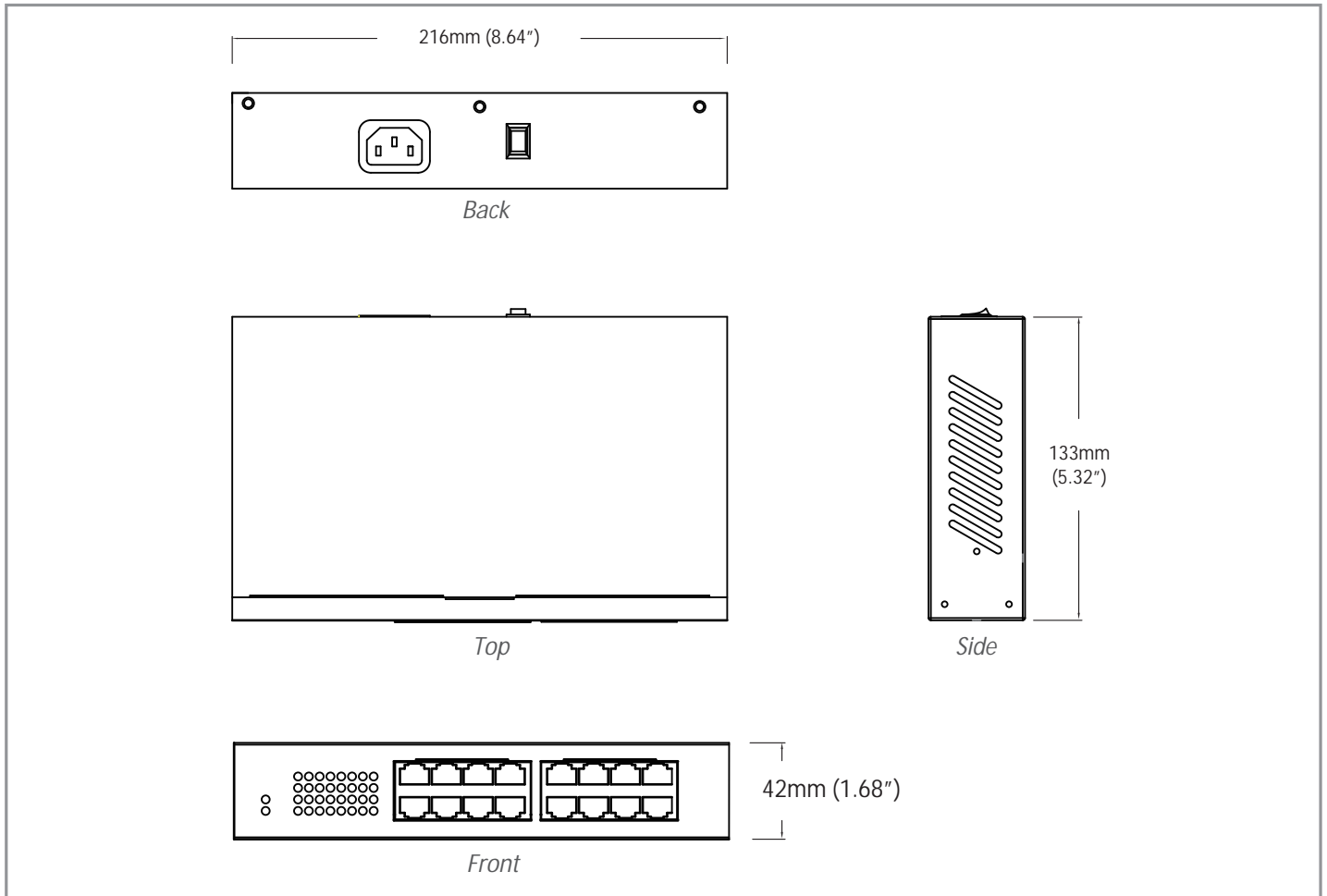

Application Diagram

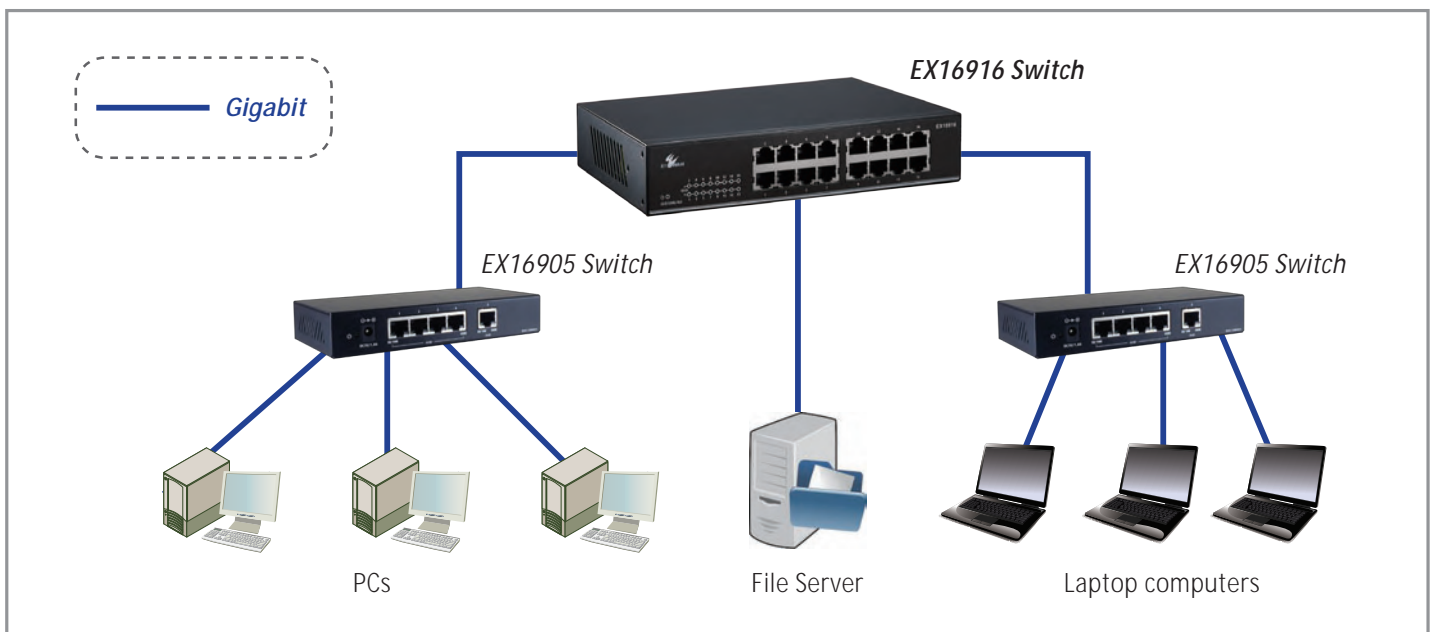

EX16926 Series

Unmanaged 26 Port Gigabit Switch with 24 RJ45 Gigabit Ports and 2 Gigabit SFP Slots



Overview

The EX16926 provides 24 Gigabit Ethernet RJ45 ports and 2 SFP ports supporting Gigabit fiber for long distance connectivity. The EX16926 is feature-rich with 10K Jumbo Frame support, full wire speed Gigabit throughput, QoS support and eco-friendly IEEE802.3az EEE (Energy Efficient Ethernet) compliant, making the EX16926 Series a powerful yet energy efficient network switch.

EtherWAN – "When Connectivity is Crucial."

Spotlight

- **Jumbo Frame Support**
 - Up to 10K bytes
- **Fiber Connectivity**
 - Two 1000BASE SFP ports
- **High Reliability**
 - Fanless design
 - No moving parts
- **Eco-friendly support**
 - IEEE802.3az EEE (Energy Efficient Ethernet) allow less consumption during periods of low data activity
- **QoS**
 - Traffic classification based on IEEE802.1p CoS

Ordering Information

Model

EX16926	Unmanaged 24-port 10/100/1000BASE with 2-port Gigabit SFP Slots Ethernet Switch
---------	---

Hardware Specifications

Technology

Standards

- IEEE802.3 10BASE-T
- IEEE802.3u 100BASE-TX/100BASE-FX
- IEEE802.3ab 1000BASE-T
- IEEE802.3z 1000BASE-SX/1000BASE-LX
- IEEE802.1x, Full duplex flow control
- IEEE802.1az Energy Efficient Ethernet
- IEEE802.1p Quality of Service (QoS)

Forward and Filtering Rate

- 14,880pps for 10Mbps
- 148,810pps for 100Mbps
- 1,488,100pps for 1000Mbps

Packet Buffer Memory

- 4.1MB

Processing Type

- Store-and-Forward
- Auto Negotiation
- Half-duplex back-pressure and IEEE802.3x full-duplex flow control
- Auto MDI/MDIX

Jumbo Frame

- 10K bytes

Address Table Size

- 4K MAC addresses

Power

Input Voltage

- 100 to 240VAC

Power Consumption

- 14.6W Max. 0.15A

Mechanical

Casing

- Metal case
- IP30

Dimensions

- 44mm (H) x 441mm (W) x 131mm (D)
(1.76" (H) x 17.64" (W) x 5.24" (D))

Weight

- 1.9Kg (4.18lbs.)

Installation

- Rack-mount (rack mounting kit included)

Interface

Ethernet Port

- 10/100/1000BASE-T: 24 ports
- 1000BASE SFP: 2 ports

LED Indicators

- Per Unit: Power (Green)
- Per Port: Link & Activity (Green)

Environment

Operating Temperature

- 0°C to 50°C (32°F to 122°F)

Storage Temperature

- -40°C to 70°C (-40°F to 158°F)

Ambient Relative Humidity

- 10% to 95% (non-condensing)

Regulatory Approvals

ISO

- Manufactured in an ISO9001 facility

EMI

FCC Class B, CE Class B and LVD EN60950-1

Dimensions

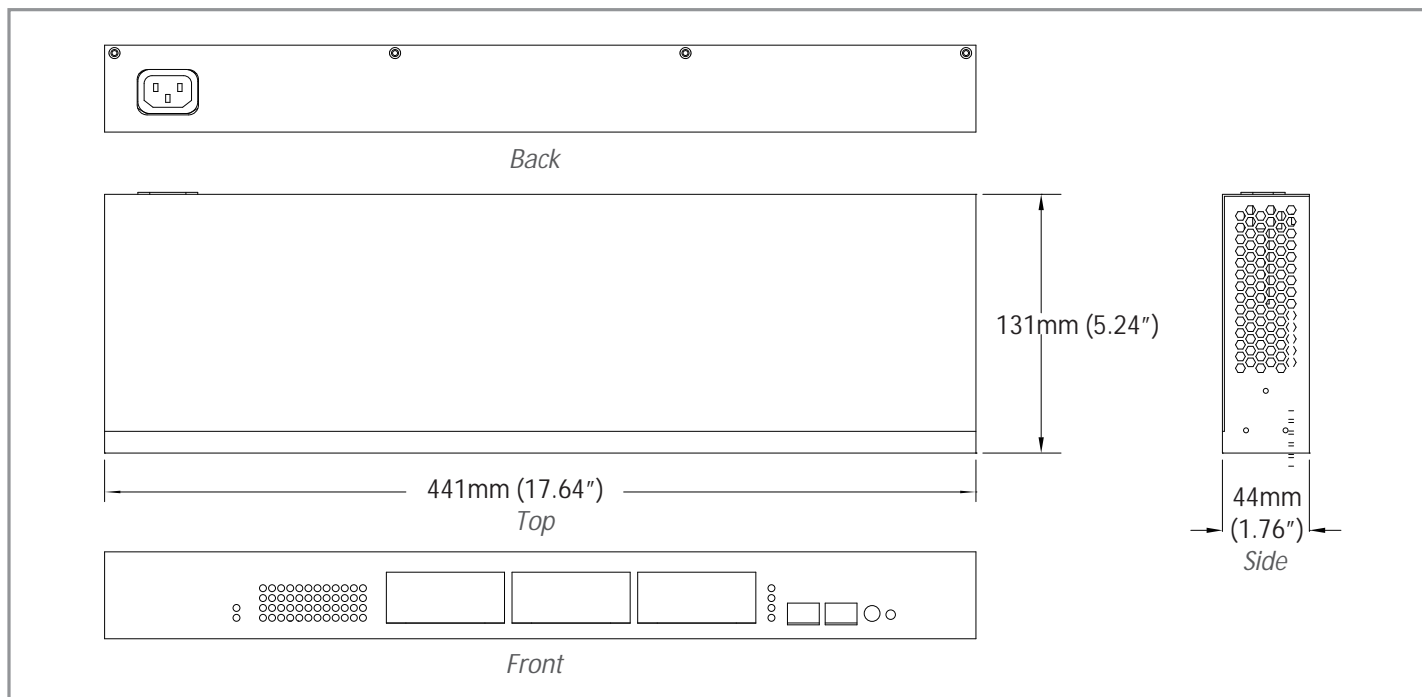

Application Diagram

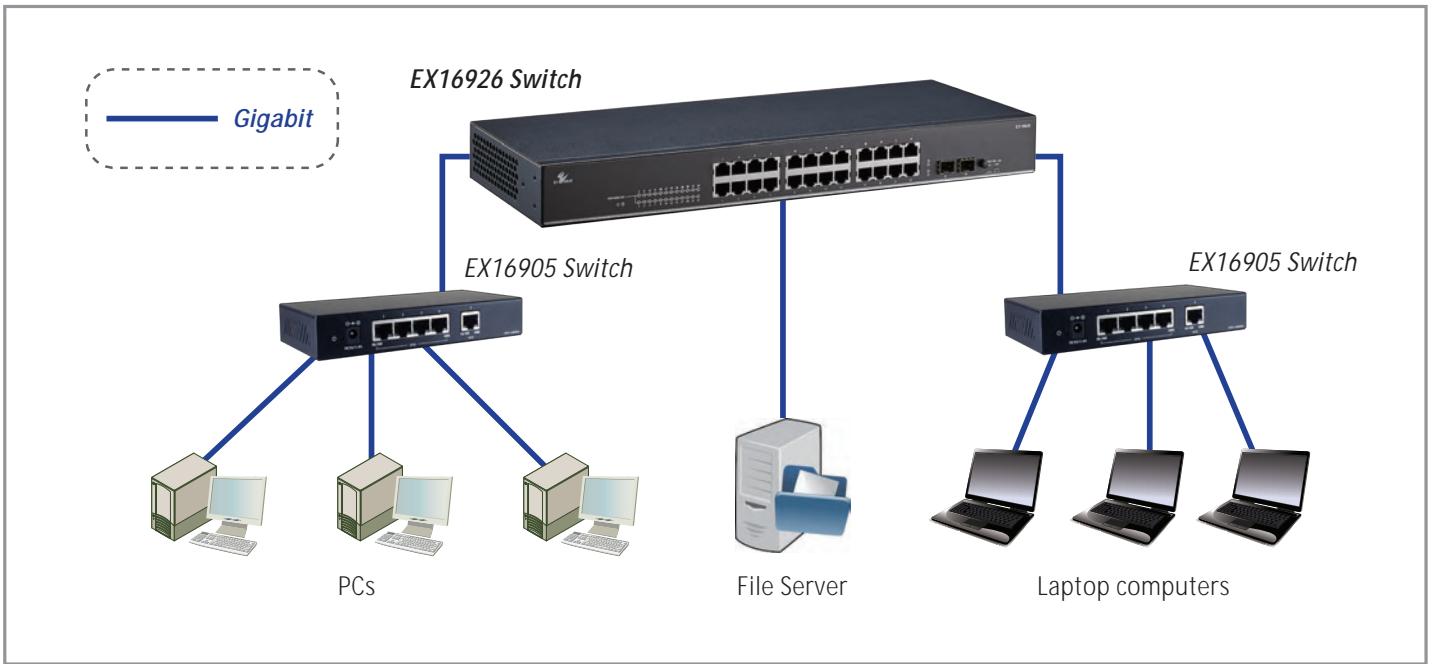

EX16900 Series

Unmanaged 5/8-port 10/100/1000BASE Ethernet Switch



Overview

EtherWAN's EX16900 Series is a compact Unmanaged Gigabit switching platform, designed for easy deployment in enterprise and small office/branch office environments

The EX16900 Series is equipped with five or eight Gigabit Ethernet ports, or a combination of Gigabit copper ports and one Gigabit fiber port for long distance connectivity. Although unmanaged, the EX16900 is feature rich with Jumbo Frame support, full wire speed Gigabit throughput, QoS support and eco-friendly IEEE802.3az EEE (Energy Efficient Ethernet) compliant, making the EX16900 Series a powerful yet energy efficient network switch.

EtherWAN — "When Connectivity is Crucial."

Spotlight

• Jumbo Frame Support

- Up to 9K bytes (EX16905/EX16914 Series)
- Up to 9720 bytes (EX16908/EX16917 Series)

• Fiber Connectivity

- Up to one 1000BASE-SX port with SC, ST and SFP options

• Compact Size

- Easy to place on the desktop with the dimensions of 160mm (W) x 80.5mm (D) x 28mm (H)

• High Reliability

- Fanless Design
- No moving parts

Hardware Specifications

Technology

Standards

- IEEE802.3 10BASE-T
- IEEE802.3u, 100BASE-TX
- IEEE802.3ab 1000BASE-T
- IEEE802.3z 1000BASE-SX/1000BASE-LX
- IEEE802.3x Full duplex flow control
- IEEE802.3az Energy Efficient Ethernet
- IEEE802.3p Quality of Service (QoS)

Forward and Filtering Rate

- 14,880pps for 10Mbps
- 148,810pps for 100Mbps
- 1,488,100pps for 1000Mbps

Packet Buffer Memory

- EX16905/EX16914: 1M bits
- EX16908/EX16917: 192 KB

Processing Type

- Store-and-Forward
- Auto Negotiation
- Half-duplex back-pressure and IEEE802.3x full-duplex flow control
- Auto MDI/MDIX

Jumbo Frame

- EX16905/EX16914: 9K
- EX16908/EX16917: 9720 bytes

Address Table Size

- EX16905/EX16914: 2048 MAC addresses
- EX16908/EX16917: 4K MAC addresses

Power

Input Voltage

- 5VDC

Power Consumption

- EX16905/EX16914: 3.5W Max.
- EX16908/EX16917: 4W Max.

Mechanical

Casing

- Metal Case

Dimensions

- 160mm (W) x 80.5mm (D) x 28mm (H)
(6.3" (W) x 3.17" (D) x 1.1" (H))

Weight

- 0.42Kg (0.92lb.)

Installation

- Wall or Shelf Mounting

Interface

Ethernet Port

- EX16905/EX16914:
10/100/1000BASE-T: 5 or 4 ports
1000BASE-SX/LX/SFP: 0 or 1 port
- EX16908/EX16917:
10/100/1000BASE-T: 8 or 7 ports
1000BASE-SX/LX/SFP: 0 or 1 port

LED Indicators

- Per Unit: Power (Green)
- Per Port: 10/100M (Green);
1000Mbps (Amber)

Environment

Operating Temperature

- 0°C to 45°C (32°F to 113°F)

Storage Temperature

- -10°C to 70°C (14°F to 158°F)

Ambient Relative Humidity

- 10% to 95% (non-condensing)

Regulatory Approvals

ISO

- Manufactured in an ISO9001 facility

Safety

UL60950

Emission Compliance

CE Mark Class A

FCC Part 15B ClassA,

VCCI Class A

Dimensions

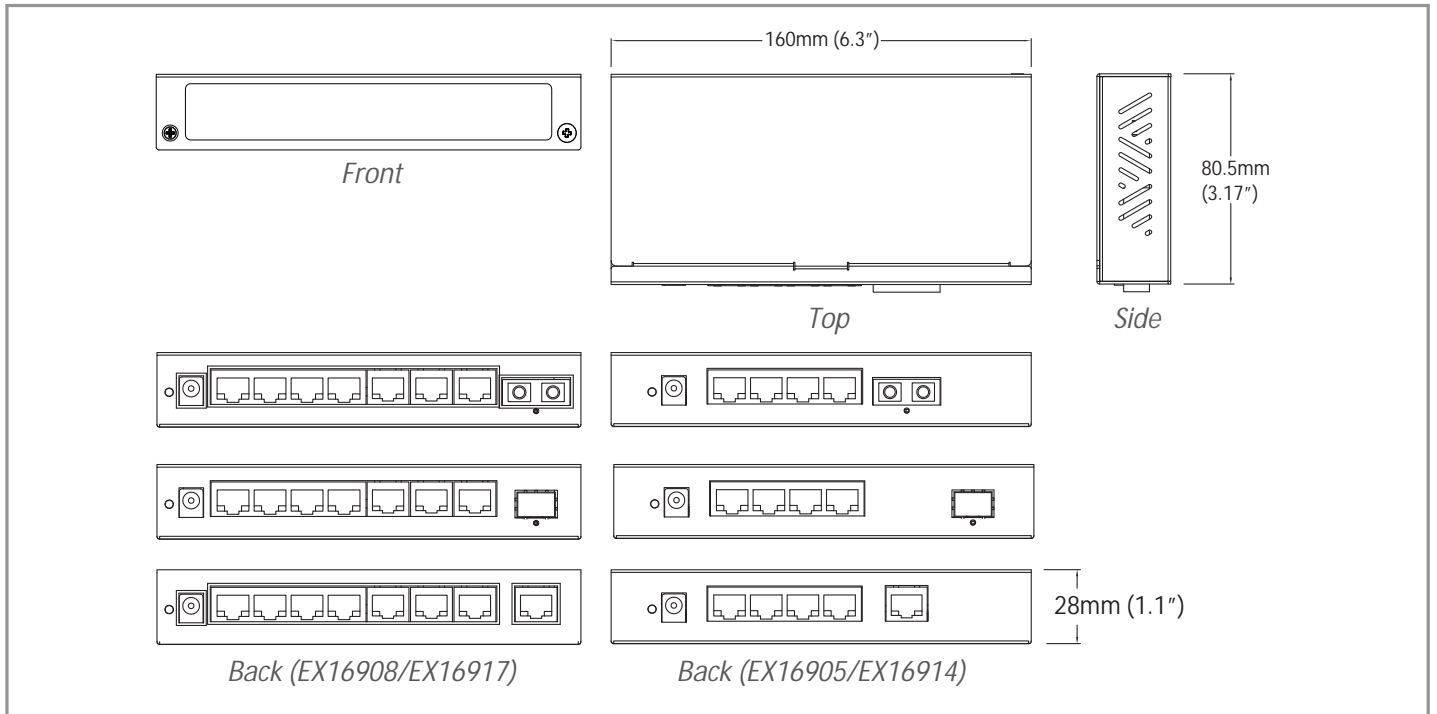

Ordering Information

Model

EX16905	Unmanaged 5-port 10/100/1000BASE-TX Gigabit Ethernet Switch
EX16914-X	Unmanaged 4-port 10/100/1000BASE-TX + 1-port 1000BASE-X Gigabit Ethernet Switch
EX16908	Unmanaged 8-port 10/100/1000BASE-TX Gigabit Ethernet Switch
EX16917-X	Unmanaged 7-port 10/100/1000BASE-TX + 1-port 1000BASE-X Gigabit Ethernet Switch

1000FX Fiber Options(X)

3	1000BASE-SX(SC)-550m
5	1000BASE-SX(ST)-550m
V	1000BASE SFP

EX1605PB/PBF1 Series EX1608PB/PBF1 Series (US Only)

Unmanaged 5/8-port 10/100BASE Ethernet Switch



Overview

EtherWAN's EX1605PB/EX1608PBF1 Series is a compact unmanaged Fast Ethernet switching platform, designed for easy deployment in small business or enterprise environments.

The EX1605PB/EX1608PBF1 Series is equipped with 5/8 Fast Ethernet ports, with the combination of Fast Ethernet copper ports and one 100FX fiber port for long distance connectivity. Although unmanaged, the EX1608PB/EX1608PBF1 is feature-rich with full wire speed Fast Ethernet throughput, making the EX1608PB/EX1608PBF1 Series a powerful network switch.

EtherWAN – "When Connectivity is Crucial."

Spotlight

• Fiber Connectivity

- Up to one 100BASE-FX port with SC and ST options
- Fiber port is available with SC or ST with a fiber connection that can reach up to 120Km (74.4miles)

• Easy to Install

- External 12VDC power adaptor
- Support wall mounting

Hardware Specifications

Technology

Standards

- IEEE802.3, 10BASE-T
- IEEE802.3u, 100BASE-TX
- IEEE802.3x, Full duplex flow control

Forward and Filtering Rate

- 14,880pps for 10Mbps
- 148,810pps for 100Mbps

Packet Buffer Memory

- 1M bits

Processing Type

- Store-and-Forward
- Auto Negotiation
- Half-duplex back-pressure and IEEE802.3x full-duplex flow control
- Auto MDI/MDIX

Address Table Size

- 2048 MAC addresses

Power

Input Voltage

- 12VDC

Power Consumption

- 3.24W Max. 0.27A @ 12VDC

Mechanical

Casing

- Metal Case

Dimensions

- 160mm (W) x 80.5mm (D) x 28mm (H)
(6.3" (W) x 3.17" (D) x 1.1" (H))

Weight

- 0.42Kg (0.92lb.)

Installation

- Wall, Shelf Mounting

Interface

Ethernet Port

- 5 or 4 10/100BASE-TX ports (EX1605PB/PBF1)
- 8 or 7 10/100BASE-TX ports (EX1608PB/PBF1)
- 0 or 1 100BASE-FX port

LED Indicators

- Per Unit: Power Status (Power)
- Per Port: 10/100TX, 100FX: Link/Activity

Environment

Operating Temperature

- 0°C to 45°C (32°F to 113°F)

Storage Temperature

- -10°C to 70°C (14°F to 158°F)

Ambient Relative Humidity

- 10% to 95% (non-condensing)

Regulatory Approvals

ISO

- Manufactured in an ISO9001 facility

Emission Compliance

CE Mark Class A and FCC Part 15 ClassA

Dimensions

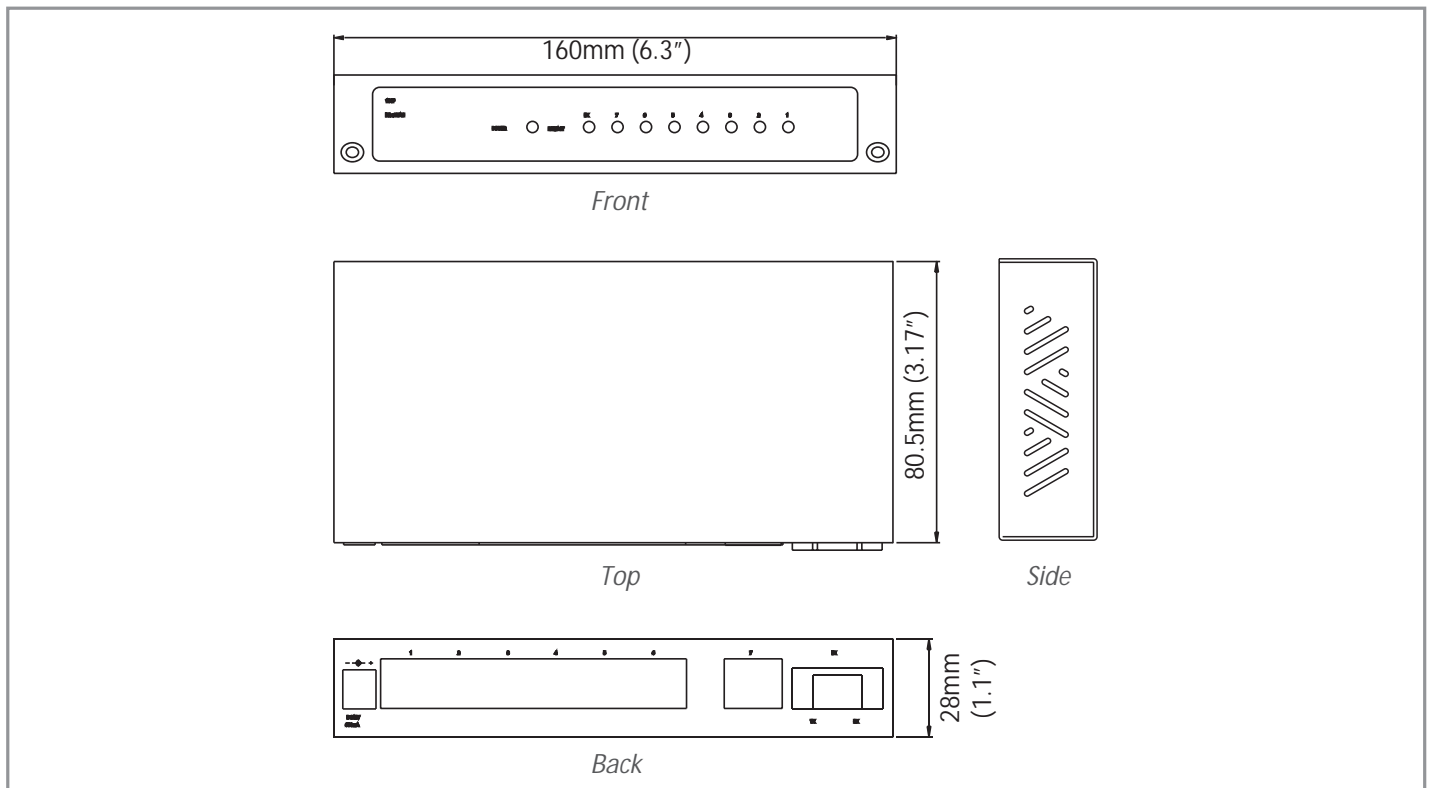

Ordering Information

Model

EX1605PB	5-port 10/100BASE-TX Unmanaged Ethernet Switch
EX1605PBFT	4-port 10/100BASE-TX + 1-port 100BASE-FX Multi Mode (ST) -2Km Unmanaged Ethernet Switch
EX1605PBFC	4-port 10/100BASE-TX + 1-port 100BASE-FX Multi Mode (SC) -2Km Unmanaged Ethernet Switch
EX1605PBFT-20	4-port 10/100BASE-TX + 1-port 100BASE-FX Single Mode (ST) -20Km Unmanaged Ethernet Switch
EX1608PB	8-port 10/100BASE-TX Unmanaged Ethernet Switch
EX1608PBFT	7-port 10/100BASE-TX + 1-port 100BASE-FX Multi Mode (ST) -2Km Unmanaged Ethernet Switch
EX1608PBFC	7-port 10/100BASE-TX + 1-port 100BASE-FX Multi Mode (SC) -2Km Unmanaged Ethernet Switch
EX1608PBFT-20	7-port 10/100BASE-TX + 1-port 100BASE-FX Single Mode (ST) -20Km Unmanaged Ethernet Switch
EX1608PBFC-15	7-port 10/100BASE-TX + 1-port 100BASE-FX Single Mode (SC) -15Km Unmanaged Ethernet Switch
EX1608PBFC-A-20	7-port 10/100BASE-TX + 1-port 100BASE-FX Single Mode (SC) WDM-TX:1310nm/RX:1550nm-20Km Unmanaged Ethernet Switch

EX1608SF Series

Unmanaged 8-port 10/100BASE Ethernet Switch



Overview

EtherWAN's EX1608SF Series is an Unmanaged Fast Ethernet switching platform, designed for easy deployment in small-business or enterprise environments.

The EX1608SF Series is equipped with eight Fast Ethernet ports, with the option of eight 100FX fiber ports for long distance connectivity. Although unmanaged, the EX1608SF is feature rich with full wire speed Fast Ethernet throughput, making the EX1608SF Series a powerful network switch.

EtherWAN – "When Connectivity is Crucial."

Spotlight

• Fiber Connectivity

- Up to eight 100BASE-FX ports with SC and ST options

• Easy to Install

- Internal universal PSU 100VAC - 240VAC, 50 - 60HZ

Hardware Specifications

Technology

Standards

- IEEE802.3 10BASE-T
- IEEE802.3u 100BASE-TX/100BASE-FX
- IEEE802.3x, Full duplex and flow control

Forward and Filtering Rate

- 14,880pps for 10Mbps
- 148,810pps for 100Mbps

Packet Buffer Memory

- 768K bits

Processing Type

- Store-and-Forward
- Half-duplex back-pressure and IEEE802.3x full-duplex flow control

Address Table Size

- 2048 MAC addresses

Power

Input

- 100 - 240VAC, 50 - 60Hz Internal Universal PSU

Power Consumption

- 12W Max.

Mechanical

Casing

- Metal Case

Dimensions

- 443.6mm (W) x 203.2mm (D) x 44mm (H)
(17.47" (W) x 8.07" (D) x 1.73" (H))
- Standard 19" rack-mount size, one-unit-height

Weight

- 2.8Kg (6.16lbs.)

Installation

- Rack Mounting

Interface

Ethernet Port

- 10/100BASE-TX: 6, 2 or 0 ports
- 100BASE-FX: 2, 6 or 8 ports

LED Indicators

- Per Unit: Power Status (Power)
- Per Port: 10/100TX, 100FX: Link/Activity, Speed,
- Full-duplex/Collision

Environment

Operating Temperature

- 0°C to 45°C (32°F to 113°F)

Storage Temperature

- -10°C to 70°C (14°F to 158°F)

Ambient Relative Humidity

- 10% to 95% (non-condensing)

Regulatory Approvals

ISO

- Manufactured in an ISO9001 facility

Emission Compliance

CE Mark Class A, FCC Part 15 ClassA

Dimensions

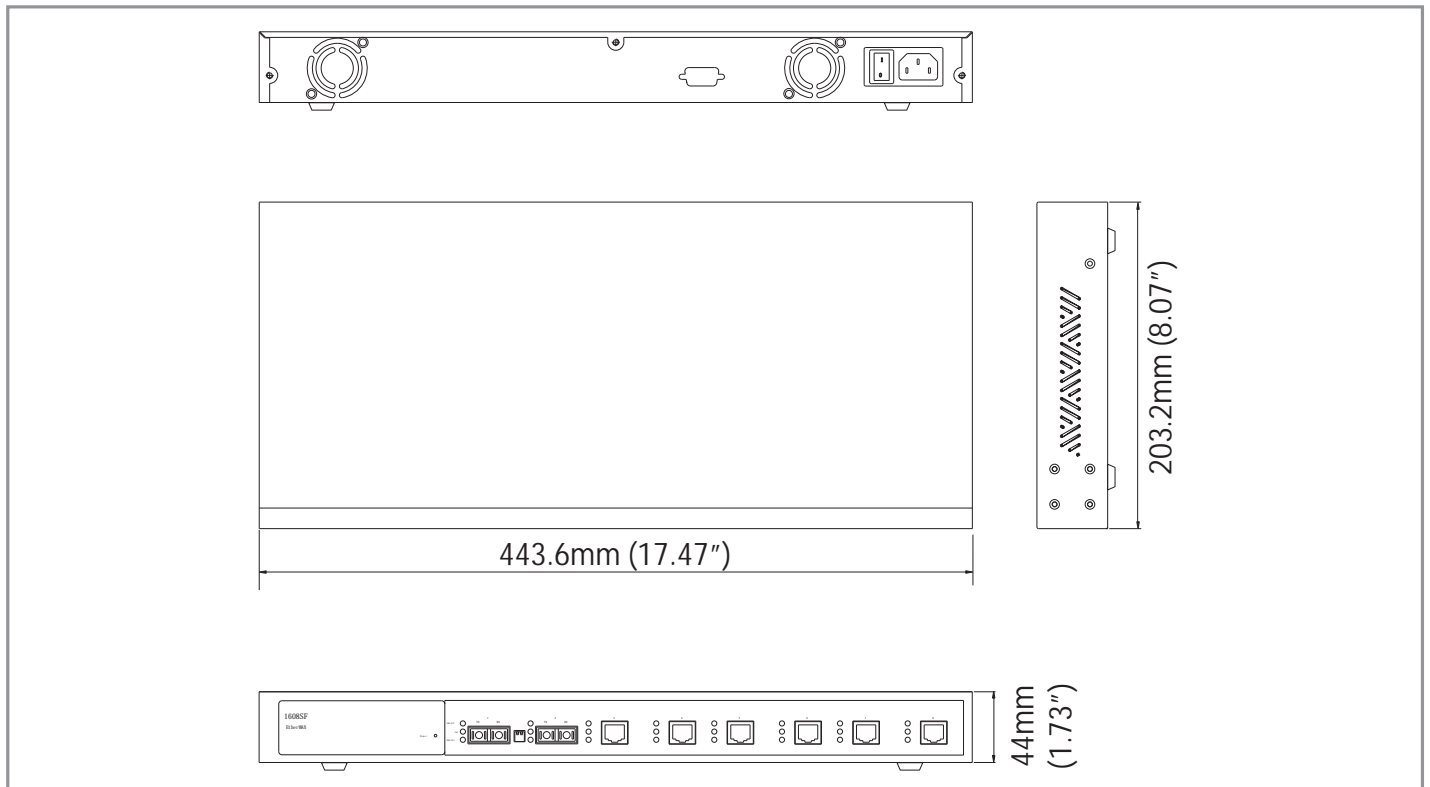

Ordering Information

Model

EX1608SFT2	6-port 10/100BASE-TX + 2-port 100BASE-FX Multi Mode (ST) - 2Km Unmanaged Ethernet Switch
EX1608SFC2	6-port 10/100BASE-TX + 2-port 100BASE-FX Multi Mode (SC) - 2Km Unmanaged Ethernet Switch
EX1608SFT2-20	6-port 10/100BASE-TX + 2-port 100BASE-FX Single Mode (ST) - 20Km Unmanaged Ethernet Switch
EX1608SFC2-15	6-port 10/100BASE-TX + 2-port 100BASE-FX Single Mode (SC) - 15Km Unmanaged Ethernet Switch
EX1608SFT6	2-port 10/100BASE-TX + 6-port 100BASE-FX Multi Mode (ST) - 2Km Unmanaged Ethernet Switch
EX1608SFC6	2-port 10/100BASE-TX + 6-port 100BASE-FX Multi Mode (SC) - 2Km Unmanaged Ethernet Switch
EX1608SFT6-20	2-port 10/100BASE-TX + 6-port 100BASE-FX Single Mode (ST) - 20Km Unmanaged Ethernet Switch
EX1608SFC6-15	2-port 10/100BASE-TX + 6-port 100BASE-FX Single Mode (SC) - 15Km Unmanaged Ethernet Switch
EX1608SFC6-40	2-port 10/100BASE-TX + 6-port 100BASE-FX Single Mode (SC) - 40Km Unmanaged Ethernet Switch
EX1608SFT8	8-port 100BASE-FX Multi Mode (ST) - 2Km Unmanaged Ethernet Switch
EX1608SFC8	8-port 100BASE-FX Multi Mode (SC) - 2Km Unmanaged Ethernet Switch
EX1608SFC8-15	8-port 100BASE-FX Single Mode (SC) - 15Km Unmanaged Ethernet Switch

Optional Accessories

KR-EW612-400		Rack mounting kit (white)
--------------	---	---------------------------