

Installation & Servicing Instructions

High efficiency condensing gas boiler E75CN/E110CN E75CP/E110CP



Pictured: E75CN, E110CN
E75CP, E110CP

CAUTION!

Read this manual thoroughly before installing, servicing, putting into operation or using this boiler and vent system.

WARNING!

Improper installation, adjustment, alteration, service or maintenance can cause property damage, personal injury (exposure of hazardous materials)* or loss of life. Refer to the user's information manual provided with this boiler. Installation and service must be performed by a qualified installer, service agency or the gas supplier (who must read and follow the supplied instructions before installing, servicing, or removing this boiler).

CAUTION!

The user manual is part of the documentation that is delivered to the installation's operator. Go through the information in this manual with the owner/operator and make sure that he or she is familiar with all necessary operating instructions.

NOTICE!

Installation and service must be performed by a qualified installer, service technician or the gas supplier.

In the Commonwealth of Massachusetts this boiler must be installed by a licensed Plumber or Gas Fitter.



WARNING!

If you do not follow these instructions exactly, a fire or explosion may result causing property damage, personal injury or loss of life.

- Do not store or use gasoline or other flammable vapors and liquids in the vicinity of this or any other appliance.
- **WHAT TO DO IF YOU SMELL GAS**
 - Do NOT try to light any appliance.
 - Do NOT touch any electrical switch.
 - Do NOT use any phone in your building.
 - Immediately call your gas supplier from a neighbor's phone. Follow the gas supplier's instructions.
 - If you cannot reach your gas supplier, call the fire department.

Rinnai®

EXPERIENCE OUR INNOVATION™

Address: 103 International Drive, Peachtree City, GA, 30269
Toll-free: 1-800-621-9419 • Fax: 678-829-1666 • www.rinnai.us



Contents of instructions

These installation instructions contain important information for the safe installation, start-up and maintenance of boilers with capacities 75,000 through 110,000 BTU/hr.

These installation instructions are intended for professional installers, who have the necessary knowledge and are approved for working on heating and gas systems.

Subject to technical changes

Changes may be made without notice to the illustrations, process steps and technical data as a result of our policy of continuous improvement.

Updating of documentation

Please contact us if you have any suggestions for improvements or corrections.

Find our contact details on the back of this manual.

California Proposition 65 lists chemical substances known to the state to cause cancer, birth defects, death, serious illness or other reproductive harm. This product may contain such substances, be their origin from fuel combustion (gas, oil) or components of the product itself.

Rinnai combi boiler complies with the State of California Lead Law (AB1953).

Content

1	Safety and general instructions	4	7	Electrical connections	46
1.1	Designated use	4	8	Boiler controls	50
1.2	Hazard definitions	4	8.1	Explanation of the function buttons	51
1.3	Symbol definitions	4	9	Starting up: Filling and de-aerating the boiler and installation	52
1.4	The following instructions must be followed	5	9.1	Requirements of the water system	52
1.5	Follow these instructions for the space heating water	6	9.2	Filling the heating system	53
1.6	Tools, materials and additional equipment	6	9.3	Hot water supply	54
1.7	Relevant Installation, Service and User manuals	7	10	Adjustments	56
1.8	Disposal	7	10.1	Altering adjustments	56
2	Regulations and guidelines	7	10.2	Activating factory settings (green button function)	59
3	Description of the boiler	8	11	Isolating the boiler	59
4	Packaging and transportation	9	12	Commissioning	60
4.1	Scope of delivery	9	12.1	Testing for gas leaks	61
4.2	Transportation	9	12.2	Testing the Ignition Safety shut off device	61
5	Installation	10	12.3	Checking the O ₂	62
5.1	Requirements for the installation room	10	12.4	Measuring the ionization current	63
5.2	Fitting the boiler	11	12.5	Installing the casing	64
5.3	Dimensions	12	13	Maintenance	64
5.3.1	Plumbing Kits	15	13.1	Periodic examination of venting systems and boiler	64
5.3.2	Clearances from boiler	16	13.2	Inspection	64
5.4	Technical specifications	17	13.3	Maintenance activities	66
6	Connecting the boiler	18	13.4	Warranty	69
6.1	Central heating system	18	14	Parts of the boiler	70
6.1.1	Plumbing Kit installation	20	15	Blocks and Errors	71
6.1.2	Side mounting kit for the Low Loss Header	24	17	Spare parts / Pièces de rechange	80
6.1.3	Safety valve	24	18	Parts list vent system	96
6.1.4	Low water cut off	24	19	Common venting guidelines	97
6.2	Expansion tank	25		Appendix A - Outdoor Reset Sensor Data	98
6.3	Underfloor heating system (plastic pipes)	25		Appendix B - Resistance table NTC sensors	99
6.4	Gas supply connection	25			
6.4.1	Gas connection with natural gas	26			
6.4.2	Gas connection with propane gas	27			
6.5	Hot water supply	28			
6.5.1	Domestic Water quality	28			
6.5.2	Domestic water treatment Accessory	28			
6.5.3	Installing a Thermostatic Mixing Valve	29			
6.5.4	Installing a valve kit	30			
6.5.5	Pressure relief Valve	30			
6.5.6	Programming domestic hot water preheat	31			
6.6	Condensate drain pipe	31			
6.7	Vent system and air supply system	32			
6.7.1	Intake / Exhaust Guidelines	32			
6.7.2a	Examples vent and air supply systems (concentric)	33			
6.7.2b	Examples vent and air supply systems (parallel)	34			
6.7.3	Installation of the vent system	35			
6.7.3.1	Boiler conversion from concentric to parallel	36			
6.7.3.2	Placing air filter	36			
6.7.4	Recommended vent/air intake terminal position	37			
6.7.4	Recommended vent/air intake terminal position	38			
6.7.5	Closet and alcove installation	39			
6.7.6	Dimensioning of the exhaust and air intake duct	40			
6.7.7	Combustion air and vent piping lengths	41			
6.7.8	Calculation of compensation factor	42			
6.7.9	Room Air System (indoor combustion air)	43			

1 Safety and general instructions

Please observe these instructions in the interest of your own safety.

1.1 Designated use

The boiler is designed for heating water for a central heating system and generating domestic hot water. The boiler is delivered with a burner controller (MCBA) pre-installed. The boiler can be fitted with a modulating outdoor reset sensor ARV12 (included with the boiler) or an On/Off thermostat or relay panel end switch (accessories).

1.2 Hazard definitions

The following defined terms are used throughout the documentation to bring attention to the presence of hazards of various risk levels. Notices give important information concerning the operation of the product.



DANGER

DANGER:

Indicates the presence of hazards that will cause severe personal injury, death or substantial property damage.



WARNING

WARNING:

Indicates the presence of hazards that can cause severe personal injury, death or substantial property damage.



CAUTION

CAUTION:

Indicates presence of hazards that will or can cause minor personal injury or property damage.



CAUTION

CAUTION:

Risk of electric shock. Indicates presence of hazards due to electric shock.



NOTICE

NOTICE:

Indicates special instructions on installation, operation or maintenance that are important but not related to personal injury or property damage.

1.3 Symbol definitions

The following (safety) symbols may be encountered in these installation instructions and on the unit:



This symbol indicates that the unit must be stored away from frost.



This symbol indicates that the packaging and/or contents can be damaged as a result of insufficient care taken during transport.



This symbol indicates that, whilst still in its packaging, the unit must be protected from weather conditions during transport and storage.

1.4 The following instructions must be followed

- The boiler must only be used for its designated purpose, as described in the Installation Instructions.
- Each unit is fitted with a data plate. Consult the details on this plate to verify whether the boiler is compliant with its intended location, e.g.: gas type, power source and venting classification.
- Only use the boiler with the accessories and spare parts listed.
- Other combinations, accessories and consumables must only be used if they are specifically designed for the intended application and do not affect the system performance and the safety requirements.
- Maintenance and repairs must only be performed by trained professionals.
- Installation of a condensing gas boiler must be reported to the relevant gas utility company and have it approved.
- You are only allowed to operate the condensing gas boiler with the vent system that has been specifically designed and approved for this type of boiler.
- Please note that local permission for the vent system and the condensate water connection to the public sewer system may be required.

You must also respect:

- The local building codes stipulating the installation rules.
- The local building codes concerning the air intake and outlet systems and the chimney connection.
- The regulations for the power supply connection.
- The technical rules laid down by the gas utility company concerning the connection of the gas connection to the local gas mains.
- The instructions and standards concerning the safety equipment for the water/ space heating system.
- The Installation Instructions for building heating systems.
- The boiler must be located in an area where leakage of the boiler or connections will not result in damage to the area adjacent to the boiler or to lower floors of the structure. When such locations cannot be avoided, it is recommended that a suitable drain pan be installed under the boiler.
- The boiler must be installed in such way that the all components are protected from water (dripping, spraying, rain etc.) during boiler operation and service.
- The boiler must not be installed on or against carpeting.
- Do not restrict or seal any air intake or outlet openings.
- If you find any defects, you must inform the owner of the system of the defect and the associated hazard in writing.



Failure to properly commission the boiler as described in section 13 may result unreliable burner operation, reduced component life, and unsafe boiler operation.



**DANGER. Gas is flammable and may cause an explosion.
Beware if you smell gas: there may be an explosion hazard!**

If the information in these instructions is not followed exactly, a fire or explosion may result causing property damage, personal injury or death.

- Do not store or use gasoline or other flammable vapors and liquids in the vicinity of this or any other appliance.



WHAT TO DO IF YOU SMELL GAS

- Do NOT try to light any appliance.
- Do NOT touch any electrical switch.
- Do NOT use any phone in your building.
- Immediately call your gas supplier from a neighbor's phone. Follow the gas supplier's instructions.
- If you cannot reach your gas supplier, call the fire department.



Should overheating occur or the gas supply fail to shut off, do not turn off or disconnect the electrical supply to the pump. Instead, shut off the gas supply at a location external to the appliance.

1.5 Follow these instructions for the space heating water

Unsuitable heating system water can cause the formation of scale or sludge, which affects system efficiency. It can also cause corrosion and reduce life of the heat exchanger.

- You must follow Rinnai guidelines for boiler water quality.
- Thoroughly flush the system prior to filling.
- Follow the Rinnai cleaning instructions.
- Never use water that has been treated by a reverse osmosis, D.I., or distilled water to soften the water to fill the heating system.
- Do not use inhibitors or other additives unless approved by Rinnai for that purpose!
- When frost protection of the heating system is desired, only use Rinnai-approved antifreezes. The allowed maximum concentration is 50%.
- When using oxygen-permeable pipes, e. g. for under floor heating systems, you must separate the system from the boiler using plate heat exchangers.
- Valve off boiler while flushing system, do not introduce any system cleaner into the boiler loop. Flush system thoroughly to remove all system cleaner before filling boiler.

Approved antifreeze: • Rhomar RhoGard Mutli-Metal (AL safe)
(max. concentration 50%) • Noble Noburst AL

Approved system cleaner: • Noble Noburst Hydronic System Cleaner
• Fernox F3 Cleaner
• Rhomar Hydro-Solv 9100

NOTICE

The system cleaners from NoBurst, Rhomar, and Fernox are not to be used in the boiler. The boiler must be closed off (valved off) from the rest of the system or not connected while the cleaners are in the system. The system should then be drained and then thoroughly flushed with clean water to remove all the system cleaner.

Approved inhibitors: • Rhomar Pro-tek 922
• Noble Noburst AL inhibitor

See the Rinnai Boiler Applications Manual or Chapter 6 and 9 of this manual for additional information.

NOTICE

If problems occur when using sanitary water with a chlorine content higher than 150 mg/l, no recourse can be made to the terms of the warranty.

1.6 Tools, materials and additional equipment

For the installation and maintenance of the boiler you will need:

- Standard tools for space heating, gas and water fitting
- Digital manometer, capable of reading both positive and negative pressure
- Combustion analyzer (intended for use with condensing boilers)
- Digital multimeter
- pH digital meter
- Metric Allen wrenches
- Metric socket wrenches

In addition, a handtruck with a fastening belt is useful.

For maintenance of the boiler you will need, apart from standard tools for space heating, gas and water fittings the following items:

- Rinnai toolkit Q and E-Series

1.7 Relevant Installation, Service and User manuals

- Approved vent system
- Rinnai Boiler Applications Manual

1.8 Disposal

- Dispose of the boiler packaging in an environmentally sound manner.
- Dispose of components of the heating system (e.g. boiler or control device), that must be replaced in an environmentally responsible manner.

2 Regulations and guidelines

The installation must comply to the requirements of the authority having jurisdiction or, in the absence of such requirements, to the latest edition of the National Fuel Gas Code, ANSI Z223.1/NFPA 54. In Canada, installation must be in accordance with the requirements of CAN/CSA B149.1, Natural Gas and Propane Installation Code.

Where required by the authority having jurisdiction, the installation must comply to the Standard for Controls and Safety Devices for Automatically Fired Boilers, ANSI/ASME CSD-1.

Install CO detectors per local regulations. Boiler requires an inspection every 2 years and maintenance every 4 years or 4000 hours. See maintenance section chapter 13.

Operating Limits of the boiler:

- Max. boiler temperature: 176 °F (80.0 °C)
- Max. operating pressure: 45 psi (3 bar)
- Max Allowable Working Temperature ASME: 200 °F (93 °C)
- Max. Allowable Working Pressure ASME: 45 psi (3 bar)

The hot water distribution system must comply with all applicable codes and regulations. When replacing an existing boiler, it is important to check the condition of the entire hot water distribution system to ensure safe operation.



NOTICE

For installations in the Commonwealth of Massachusetts, the following local requirements apply in addition to all other applicable NFPA requirements:

For direct-vent boilers, mechanical-vent heating appliances or domestic hot water equipment, where the bottom of the vent terminal and the intake is installed below four feet above grade the following requirements must comply:

- 1) If not present on each floor level where there are bedrooms, a carbon monoxide detector and alarm must be placed in a living area outside the bedrooms. The carbon monoxide detector and alarm must comply with NFPA 720 (2005 Edition).
- 2) A carbon Monoxide detector and alarm shall be located in the room that houses the appliance and/or equipment and shall:
 - a) Be powered by the same electrical circuit as the appliance and/or equipment such that only one service switch services both the appliance and the carbon monoxide detector;
 - b) Have battery back-up power;
 - c) Meet ANSI/UL 2034 Standards and comply with NFPA 720 (2005 Edition); and
 - d) Have been approved and listed by a Nationally Recognized Testing Lab as recognized under 527 CMR.
- 3) A product-approved vent terminal must be used, and if applicable, a product approved air intake must be used. Installation shall be performed in strict compliance with the manufacturer's instructions. A copy of the installation instructions shall remain with the appliance and/or equipment at the completion of the installation.

- 4) A metal or plastic identification plate shall be mounted at the exterior of the building, four feet directly above the location of vent terminal. The plate shall be of sufficient size to be easily read from a distance of eight feet away, and read **“Gas Vent Directly Below”**.

For direct-vent boilers mechanical-vent heating boilers or domestic hot water equipment where the bottom of the vent terminal and the intake is installed higher than four feet above grade the following requirements must comply:

- 1) If not present on each floor level where there are bedrooms, a carbon monoxide detector and alarm must be placed in a living area outside the bedrooms. The carbon monoxide detector and alarm must comply with NFPA 720 (2005 Edition).
- 2) A carbon monoxide detector shall:
 - a) Be located in the room where the boiler and/or equipment is located;
 - b) Be either hard-wired or battery powered or both; and:
 - c) Shall comply with NFPA 720 (2005 Edition).
- 3) A product-approved vent terminal must be used, and if applicable, a product-approved air intake must be used. Installation shall be in strict compliance with the manufacturer’s instructions. A copy of the installation instructions shall remain with the appliance and/or equipment at the completion of the installation.

3 Description of the boiler

Room sealed boiler
The boiler retrieves its combustion air from outside then discharges the flue gasses to the outside.

Condensing
Retrieves heat as much as possible from the flue gasses. Water condensates on the heat exchanger.

Modulating
Stepless higher or lower burning according to the heat demand.

The Rinnai E boiler is a room sealed, condensing and modulating central heating boiler, with an integrated DHW facility.

The boiler is provided with a compact stainless steel heat exchanger with smooth tubes. This design is a well thought out principle using durable materials. The boiler burns gas for supplying heat. The heat is transferred in the heat exchanger to the water in the central heating system. By cooling down the exhaust gases condensate is formed. This results in high efficiency. The condensate, which has no effect on the heat exchanger and the function of the boiler, is drained through condensate collector trap.

The boiler is provided with an intelligent control system (CMS Control Management System). The boiler anticipates the heat demand of the central heating system or the domestic hot water facility system.

When an outdoor sensor is connected to the boiler it will operate weather dependantly using outdoor reset. This means that the boiler control measures the outside temperature and supply temperature. With this data the boiler calculates the optimal supply temperature for the installation.

Explanation of the appliance type: Rinnai E110CN
 E = Type
 110 = Nominal load in (x1000) BTU
 C = C = Combi
 N = Natural Gas (P = Propane Gas)

Different boilertypes:

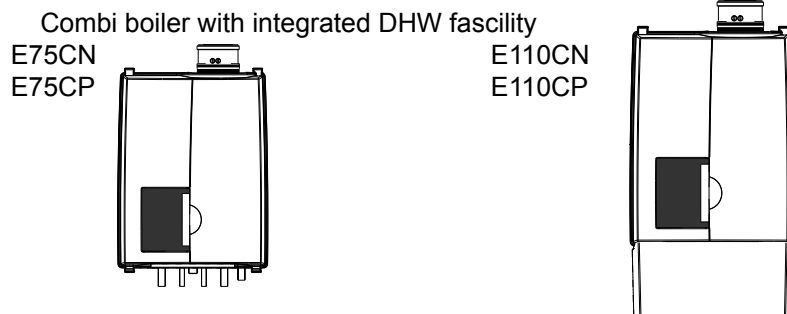

4 Packaging and transportation

4.1 Scope of delivery

The boiler is supplied ready for use.

- Please check if the packaging is intact.
- Check if all the items listed are included in the delivery.

The supply kit contents:

Description	Amount	
	E75C N	E110C N
	E75C P	E110C P
Boiler with:		
Outdoor reset sensor ARV12	1	1
Compression ring Ø22 brass	2	2
Compression ring Ø15 brass	4	4
Cover air supply Ø120/Ø80	1	1
Gasket vent system ø80	1	1
Power cable pull safety E-Series	1	1
Screw 4,8X16mm	4	4
Nut W1.1/8x1/14 22 Compression fitting	2	2
Screw 6X60mm	3	3
Lip-ring flue pipe ø80	1	1
Feed through + plug flue gas	1	1
Cap de-aerator	1	1
Flow restriction MR01 FG 7,6L white	1	
Flow restriction MR01 FG 17,5L green		1
Adapter fitting 15mm x 3/4"NPT ext.	2	2
Nut 15mm compression fitting	2	2
Flue adapter Ø80/Ø3" pps UL appr.	2	2
Wall mounting suspension bracket	1	1
Plumbing kit E-Series	1	1
3/4" Gas valve	1	1
Line voltage input connector 3 pole grey	1	1
Template	1	1
Installation & Service Instructions	1	1
User information manual	1	1
Warranty document	1	1
ICSL book	1	1

4.2 Transportation



CAUTION

The boiler may be damaged when not secured properly.

- Only transport the boiler using appropriate transportation equipment, such as a handtruck with a fastening belt or special equipment for maneuvering steps.
 - When shipping the boiler must be secured on the transportation equipment to prevent it from falling off.
 - Protect all parts against impacts if they are to be transported.
 - Follow the transportation markings on the packaging.
- Packaged boilers must always be lifted and carried by two people, or you must use a handtruck or special equipment for transport.

5.1 Requirements for the installation room



DANGER

- The room where the boiler will be installed must always be frost free.
- Do not store or use gasoline or other flammable vapors and liquids in the vicinity of this or any other appliance.
- Never use or store any chlorinated detergents or halogenated hydrocarbons (e.g. in spraycans, solvents and detergents, paints, adhesives) in proximity of the boiler.
- The boiler must be installed in such a way that it is protected from water (dripping, spraying, rain, etc.) during boiler operation and service (circulator replacement, condensate trap, control replacement, etc.)
- This boiler is for intended for indoor installations only.

Products to avoid present in boiler room and/or around combustion air intake

Spray cans containing chloro-/fluorocarbons
Ammonium and/or ammonium solutions
Permanent wave solutions (hair product)
Chlorinated waxes and/or cleaners
Swimming pool chemicals based on chlorine
Calcium chloride used for thawing
Sodium chloride used for water softening
Refrigerant leaks
Paint or varnish removers
Hydrochloric acid/muriatic acid
Cements and glues
Antistatic fabric softeners used in clothes dryers
Chlorine-type bleaches, detergents, and cleaning solvents found in household laundry rooms
Adhesives used to fasten building products and other similar products

Areas likely to have contaminants

Dry cleaning/laundry areas and establishments
Swimming pools
Metal fabrication plants
Beauty shops
Refrigeration repair shops
Photo processing plants
Auto body shops
Plastic manufacturing plants
Furniture refinishing areas and establishments
New building construction
Remodeling areas
Garages with workshops

5.2 Fitting the boiler

- Remove the packaging materials.



- **Lay the boiler on its back during unpacking. Remove the casing from the boiler. This part can be left apart during installation. It must be placed on the boiler and fixed with the screw behind the door and in the 4 quick releases before the boiler is started up.**



Turn the boiler to its side and remove the wall bracket from the back of the boiler by removing the 2 screws.

The boiler can be mounted practically to any wall with the suspension bracket and the enclosed mounting equipment.

- The wall must be flat and of sufficient strength in order to be able to securely hold and support the boiler weight with its water content.
- Take note of the necessary space around the boiler for installation of venting system, pipework and servicing. See drawing on pages 12 to 15.

The location of the boiler can be determined by using the template supplied with the boiler documentation. Remember to account for the spacing of the plumbing kit.

- Drill the necessary holes using the template
- Install the mounting bracket to the wall using the supplied mounting materials



Lifting and carrying precautions:

To avoid personal injury please follow these recommendations:

- **Always lift the boiler with 2 people or use special equipment.**
- **When lifting the boiler, bend the knees, and keep the back straight and feet apart.**
- **Do not lift and twist at the same time.**
- **Lift and carry the boiler close to the body.**
- **Wear protective clothing and gloves to protect from any sharp edges.**



Lift the boiler only by the boiler's rear wall.

- Dispose the packaging materials.

5.3 Dimensions

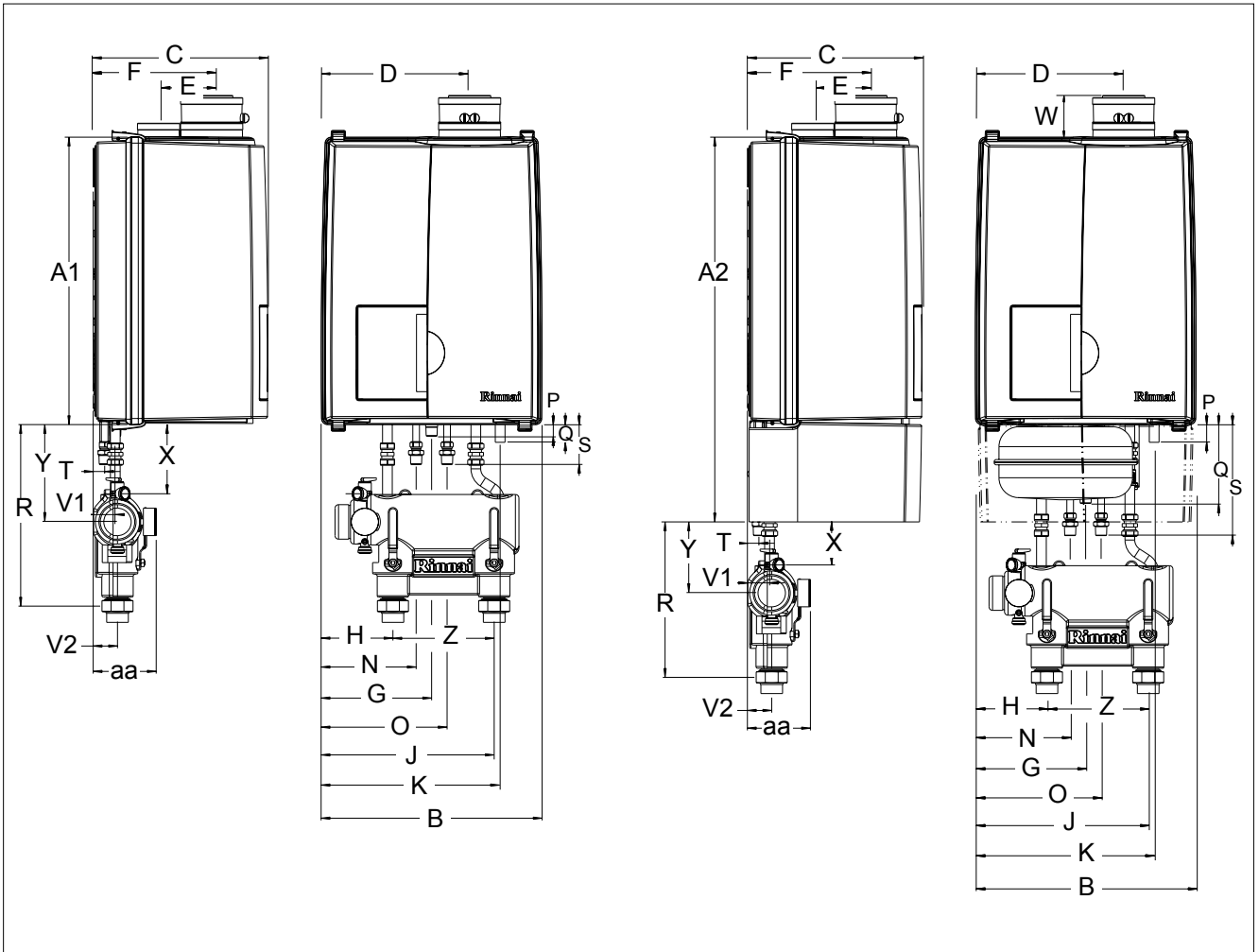

dimensions

figure 1

Dimensions

	Boiler type	Combi	
		E75CN E75CP	E110CN E110CP
		inches / mm	inches / mm
A1	Height	25.6" / 650	25.6" / 650
A2	Height with expansion tank		34.3" / 870
B	Width	19.7" / 500	19.7" / 500
C	Depth	15.6" / 395	15.6" / 395
D	Left side / vent	13.2" / 335	13.2" / 335
E	Center to center / vent and air supply	4.7" / 120	4.7" / 120
F	Back / vent	10.6" / 270	10.6" / 270
G	Left side / gas pipe	9.8" / 250	9.8" / 250
H	Left side / supply pipe	5.9" / 150	5.9" / 150
J	Left side / return pipe	13.8" / 350	13.8" / 350
K	Left side / condensate pipe	15.9" / 405	15.9" / 405
N	Left side / cold water pipe	11.2" / 285	11.2" / 285
O	Left side / hot water pipe	8.5" / 215	8.5" / 215
P	Pipe length of g*	0.7" / 19	8.5" / 215
Q	Pipe length of c*	1.6" / 40	1.6" / 40
R	Pipe length of f and r*	16" / 410	13.8" / 351
S	Pipe length of k and w*	2" / 50	6.3" / 160
T	Back / Center of pipe c, k and w*	1" / 26	1" / 26
V1	Back / Center of pipe f, g and r*	2" / 50	2" / 50
V2	Back / Center of pipe f and r*	2.2" / 55	2.2" / 55
W	Pipe length vent co-axial	3.7" / 95	3.7" / 95
	Pipe length vent parallel	7" / 177	7" / 177
X	Bottom side boiler to center safety valve	6" / 156	3.8" / 97
Y	Bottom side boiler to center header	8.7" / 221	6.4" / 162
Z	Center to center of f and r*	9" / 229	9" / 229
aa	Depth plumbing kit	5.6" / 143	5.6" / 143

*) See figure 2

dimensions

table 1

Dimensions

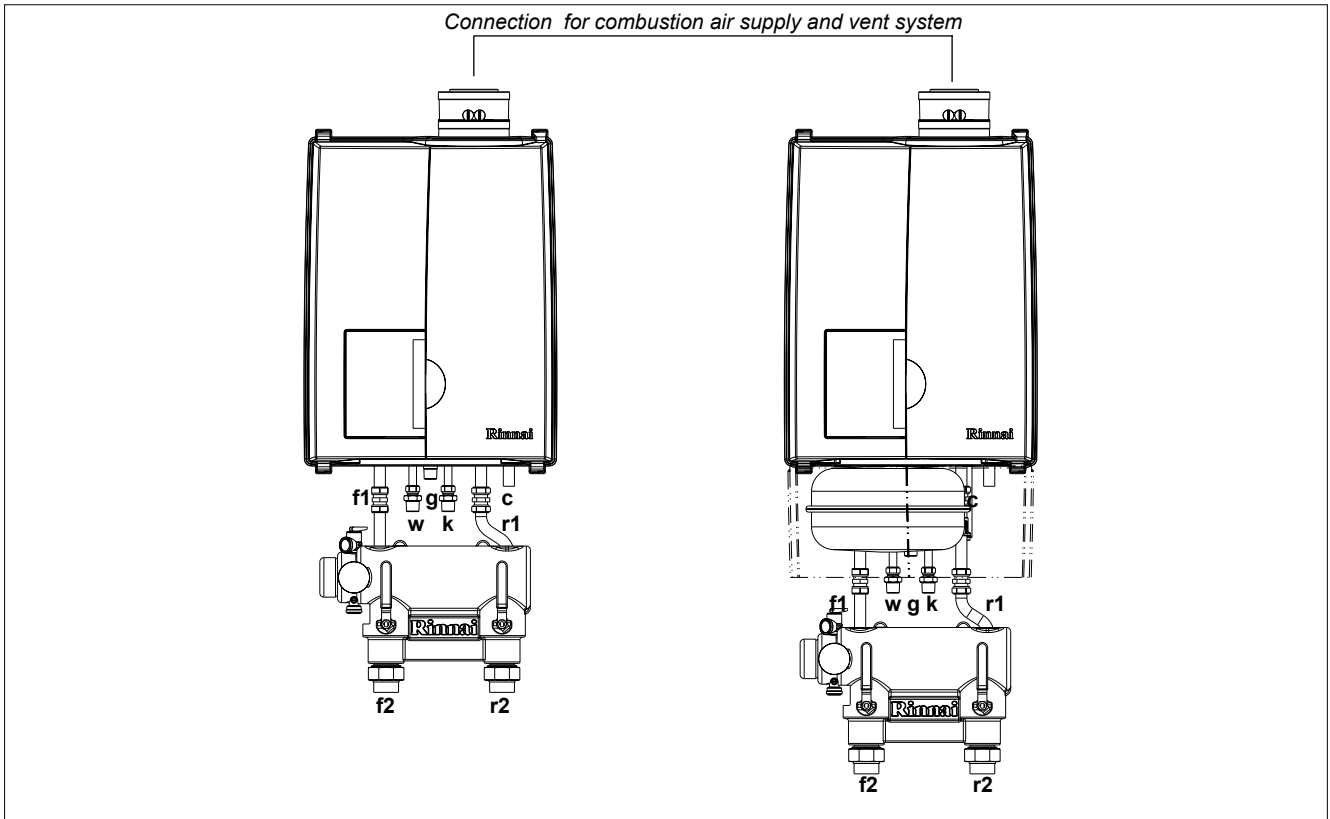

boiler connections / mounting points

figure 2

	Boiler type	Combi	
		E75CN E75CP	E110CN E110CP
Vent system / Combustion air supply		80/125mm	80/125mm
Gas pipe	g	3/4"M-NPT	3/4"M-NPT
Supply pipe	boiler side - f1	22mm	22mm
	system side - f2	1 1/4"M-NPT	1 1/4"M-NPT
Return pipe	boiler side - r1	22mm	22mm
	system side - r2	1 1/4"M-NPT	1 1/4"M-NPT
Condensate pipe	c	0.87" / 22mm	0.87" / 22mm
Cold water pipe	k	0.59" x 3/4"M-NPT /	G1/2"x
		15mm	3/4"M-NPT
Hot water pipe	w	0.59" x 3/4"M-NPT /	G1/2"x
		15mm	3/4"M-NPT

connection diameters

table 2

5.3.1 Plumbing Kits

Rinnai supplies with each type of boiler a Plumbing kit. Find below the dimensions. See chapter 6.1 for additional information.

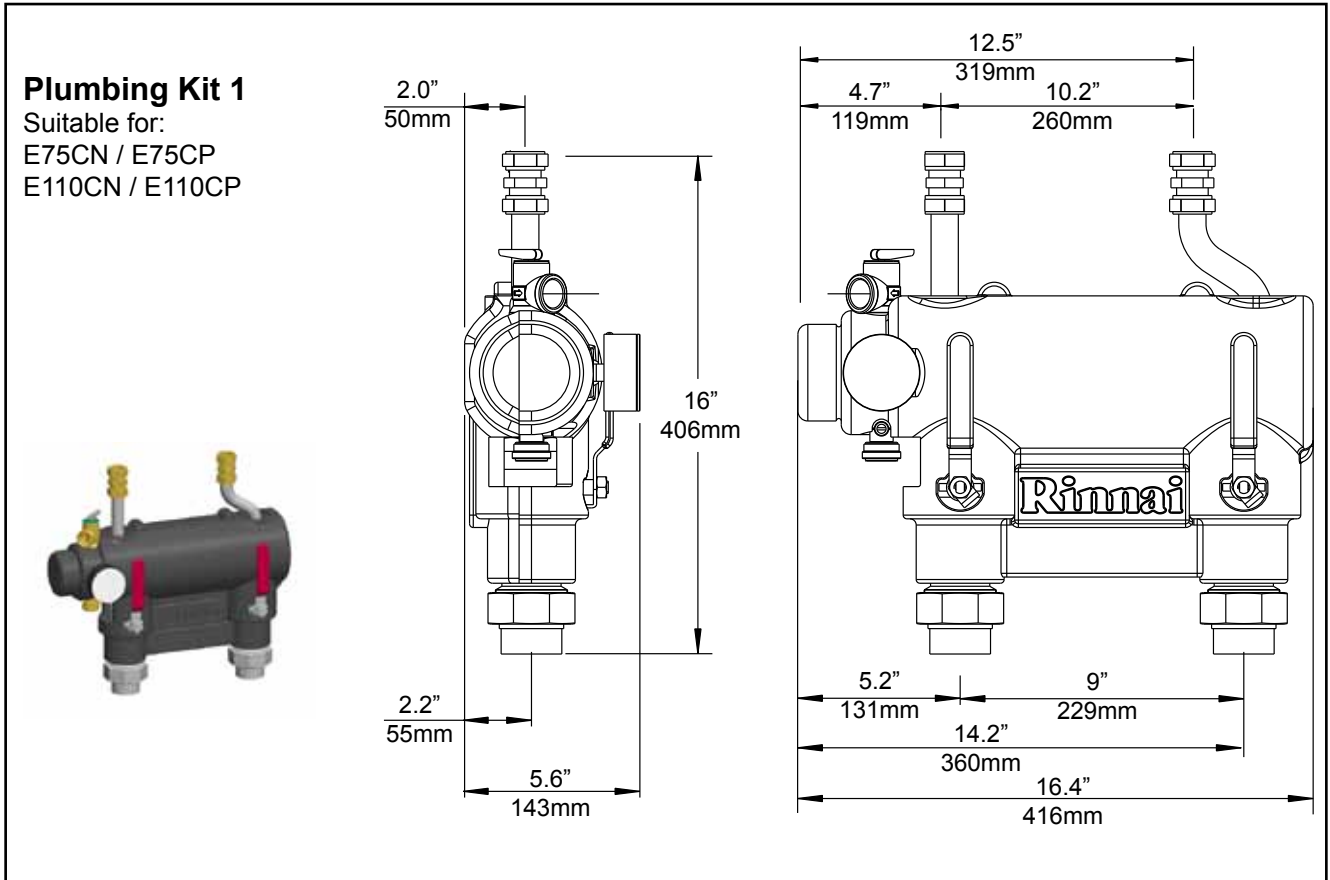

plumbing kit 1

figure 3

5.3.2 Clearances from boiler

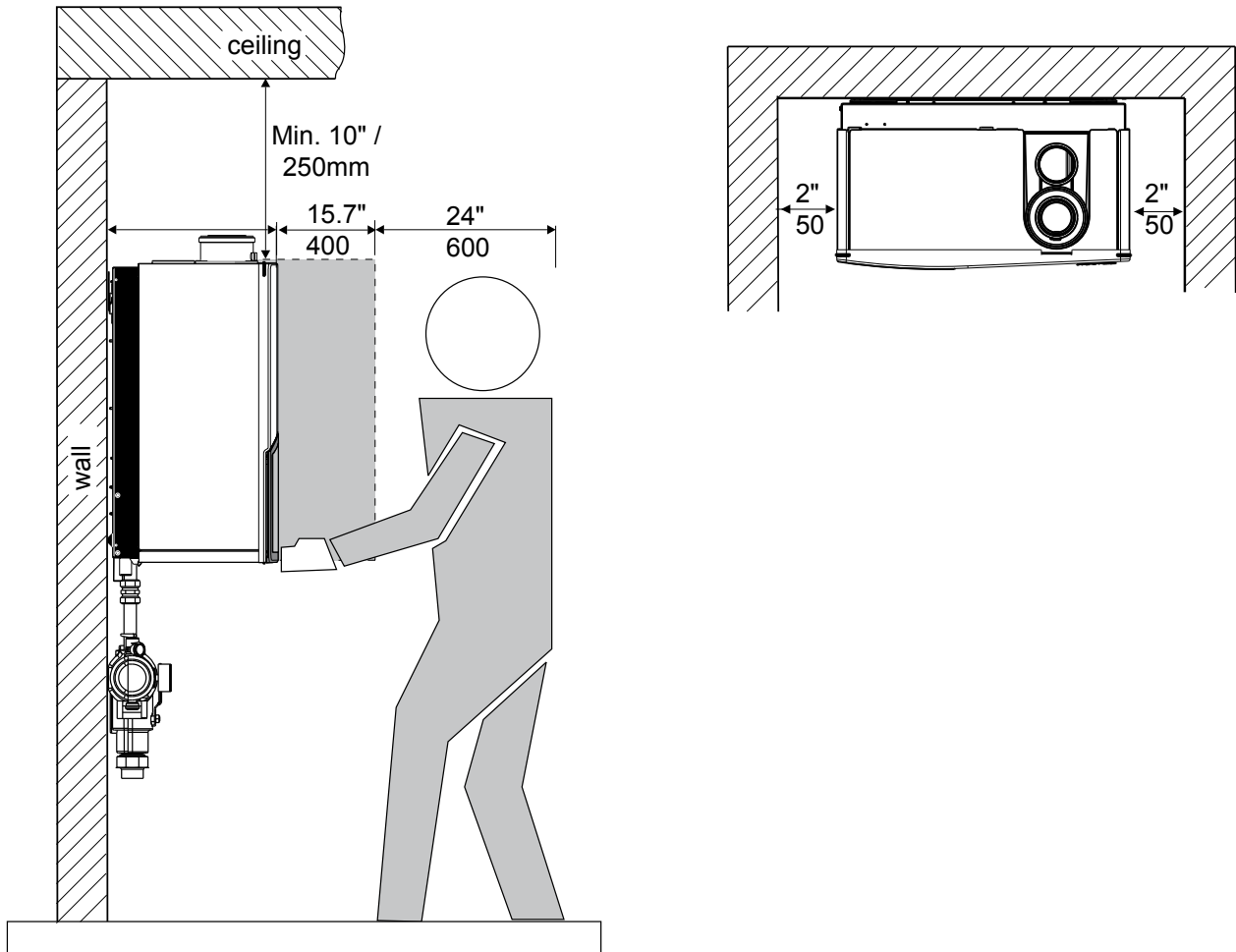

service clearances to the boiler

figure 4

	Minimum required clearances to combustibles All types	Minimum required clearances to non-combustibles All types	Recommended service clearances All types
	inch / mm	inch / mm	inch / mm
Top of boiler	2" / 50	2" / 50	10" / 250
Back of boiler	0"	0"	0
Front of boiler	6" / 150	6" / 150	24" / 600
Left side of boiler	2" / 50	2" / 50	2" / 50
Right side of boiler	2" / 50	2" / 50	2" / 50
Floor / Ground to bottom of boiler	12" / 300	12" / 300	30" / 762
Floor/ Ground to bottom Low loss header	0"	0"	12" / 300
Vent	0"	0"	0"

clearances to the boiler

table 3

For closet installation: clearance is 1" / 25mm from the front.

Low Loss Header

Clearances to combustible and non-Combustible is 0 inch for sides, top, front and floor/ground
The recommended service clearance to the bottom of the low loss header is 12 inches.

5.4 Technical specifications

Boiler type		E-Series	
		Combi	
		E75CN E75CP	E110CN E110CP
Input Hs CH	BTU/hr kW	75,000 22	110,000 32
Q _n Output non-condensing CH	BTU/hr kW	67,500 19.8	98,000 28.8
Q _n Output EN677 efficiency CH	BTU/hr kW	74,100 21.7	108,000 31.7
Q _n Output AFUE CH	BTU/hr kW	72,400 21.2	105,700 30.7
Efficiency at 98.6/86°F (36/30°C) part load, Hs, EN677 CH	%	98.8	99.0
AFUE according IBR	%	96.5	96.1
O ₂ (at full load)	%	Natural gas: 4.4 - 4.7 (Propane: 4.8 - 5.1)	
Electr. power consumption max.	W	145	
Electr. power consumption stand by	W	14	
Current	V/Hz	120Vac/60Hz	
Fuse rating	A	5AF & 4AT	
Degree of protection acc. EN 60529		IPX4D (IPX0D in case of room air)	
Weight (empty)	lbs / kg	91 / 39	101 / 40
Water content CH	gallon / liter	0.9 / 3.5	1.3 / 5
Water content DHW	gallon / liter	0.13 / 0.5	0.18 / 0.7
Water content Plumbing Kit	gallon / liter	0.55 / 2.1	
After run time pump CH	min	5	
After run time pump DHW	min	1	
P _{MS} Water pressure min.-max.	PSI / bar	14 - 43 / 1 - 3	
P _{MW} Water pressure DHW max.	PSI / bar	150 / 10	
Flow temperature max.	°F / °C	176 / 80	
Pump type		UPS20-48	UPS20-58
Available pump height CH	PSI / kPa	3.8 / 26	0.7 / 5
Approvals		ASME, CSA	
DHW flow (at ΔT50°F)	gallon/min		4.6
DHW flow (at ΔT27.8°C)	liter/min		17.4
DHW flow (at ΔT75°F)	gallon/min	2.1	3.2
DHW flow (at ΔT41.7°C)	liter/min	7.9	12.1
Max. DHW flow rate	gallon/min liter/min	2.1 7.9	4.6 17.4
DHW temperature (T _{in} =50°F (10°C))	°F / °C	140 / 60	
Pressure difference DHW	PSI / bar	2.9 / 0.2	4.4
Content expansion vessel	gallon / liter	2.1 / 8	3.1 / 12
Acceptance volume expansion vessel	gallon / liter	0.8 / 3	1.2 / 4.5
Pre-charge pressure expansion vessel	PSI / bar	14.5 / 1	
CSA number		2183087	
CRN number		8101.7CL	

Technical specifications

Table 4

The boiler has the following connection pipes;

- The central heating circuit pipes.
These must be connected to the plumbing kit by means of adapter fittings. See further chapter 6.1;
- The gas supply pipe.
It is provided with a 3/4" male thread into which the tail piece of the gas valve can be screwed. See further chapter 6.4;
- Cold and hot water pipes for domestic hot water (DHW).
These consist of 3/4" (15 mm) copper pipe and can be connected to the installation by means of 1/2" M-NPT adapter fittings. See further chapter 6.5;
- The condensation drain pipe.
It consists of an oval 1" (22 mm) plastic pipe. The drain pipe can be connected to this by means of an open connection. If the open connection is fitted in a different location, then the pipe can be lengthened by means of a 1 1/4" (32 mm) PVC sleeve. See further chapter 6.6;
- The vent system and air supply system.
It consists of a concentric connection 3" / 5" (80/125 mm). The boiler can be converted to a twin pipe connection that will accept 80mm flue and intake air or with the use of the included adapters 3" PVC/CPVC flue and intake. See further chapter 6.7.



NOTICE

The pipe to be connected to the boiler must be cleaned before connecting in order to prevent dirt from entering and damaging the boiler.

6.1 Central heating system

Connect the central heating system according to its instructions.

The boiler pipes can be connected to the installation by means of compression fittings. Reducers should be used for connecting to thick-walled pipe (welded or threaded).



NOTICE

When removing the plastic sealing caps from the pipes, dirty testing water may drain from the boiler.



NOTICE

A Plumbing Kit must be fitted to the boiler.



NOTICE

The boiler, when used in connection with a refrigeration system, must be installed so the chilled medium is piped in parallel with the boiler with appropriate valves to prevent the chilled medium from entering the boiler.



NOTICE

The boiler piping system of a hot water boiler connected to heating coils located in air handling units where they may be exposed to refrigerated air circulation must be equipped with flow control valves or other automatic means to prevent gravity circulation of the boiler water during the cooling cycle.

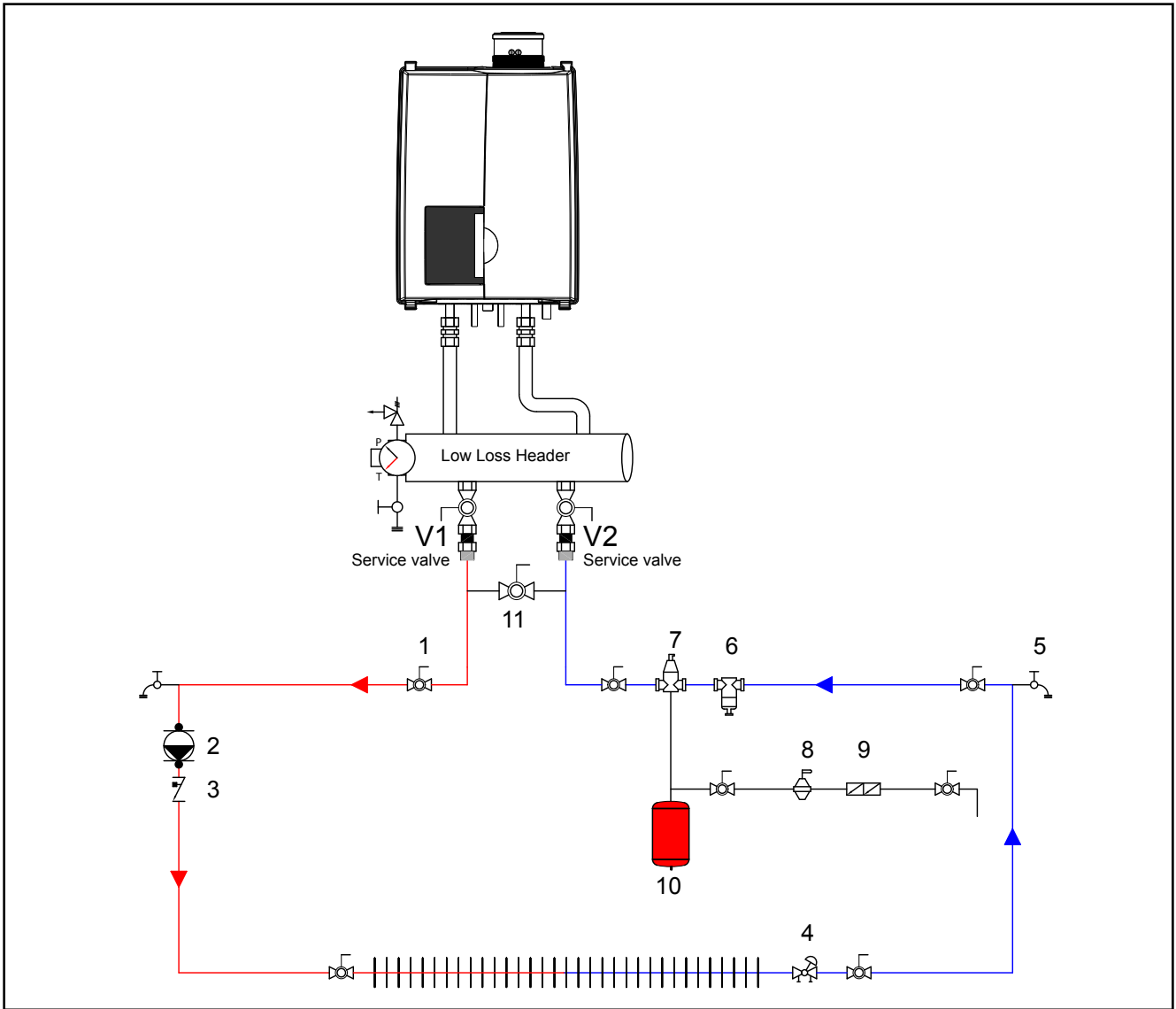

Boiler basic piping

fig. 5

1. shut off valve
2. system circulator
3. check valve
4. balancing valve
5. boiler drain valve
6. dirt trap
7. air separator
8. automatic fill valve
9. back flow preventer
10. expansion tank
11. bypass for system cleaning

6.1.1 Plumbing Kit installation

Rinnai supplies specific Plumbing Kits with each boiler type, which must be fitted directly underneath the boiler on the supply and return pipe. Use of the Rinnai boiler without the plumbing kit will void the warranty.

i NOTICE

To protect the entire heating system we recommend installing a dirt particle trap in the return circuit. When the boiler is installed to an existing heating system this trap is required. Use of a Y strainer is not permitted as substitute for a dirt trap.

- Install shut-off valves immediately before and after the dirt particle filter to allow the filter to be cleaned.
- Position 3 (figure 6) is a garden hose thread boiler drain, that can be used to drain the boiler or add water treatment additives to the system, such as inhibitors or glycol.
- Position 4 (figure 6) is the supply connection for an indirect tank when used with the optional 3-way valve kit.
- For information on locating the expansion tank and system fill, please see the Rinnai Boiler Applications Manual.

i NOTICE

Thoroughly flush all pipes and radiators. We recommend the use of a Rinnai approved system cleaner. Refer to the Rinnai Boiler Applications Manual for an approved list of Rinnai system cleaners.

- Refer to the installation template and chapter 5.3 for the pipe connection dimensions.
- Fit the bronze adapter fittings, supplied with the boiler (fig. 6, pos. 4) first to the Plumbing Kit and then to the boiler.

i NOTICE

The plumbing kit is not intended to support the weight of the piping. Appropriate piping supports should be used to support all attached piping to the boiler and plumbing kit.

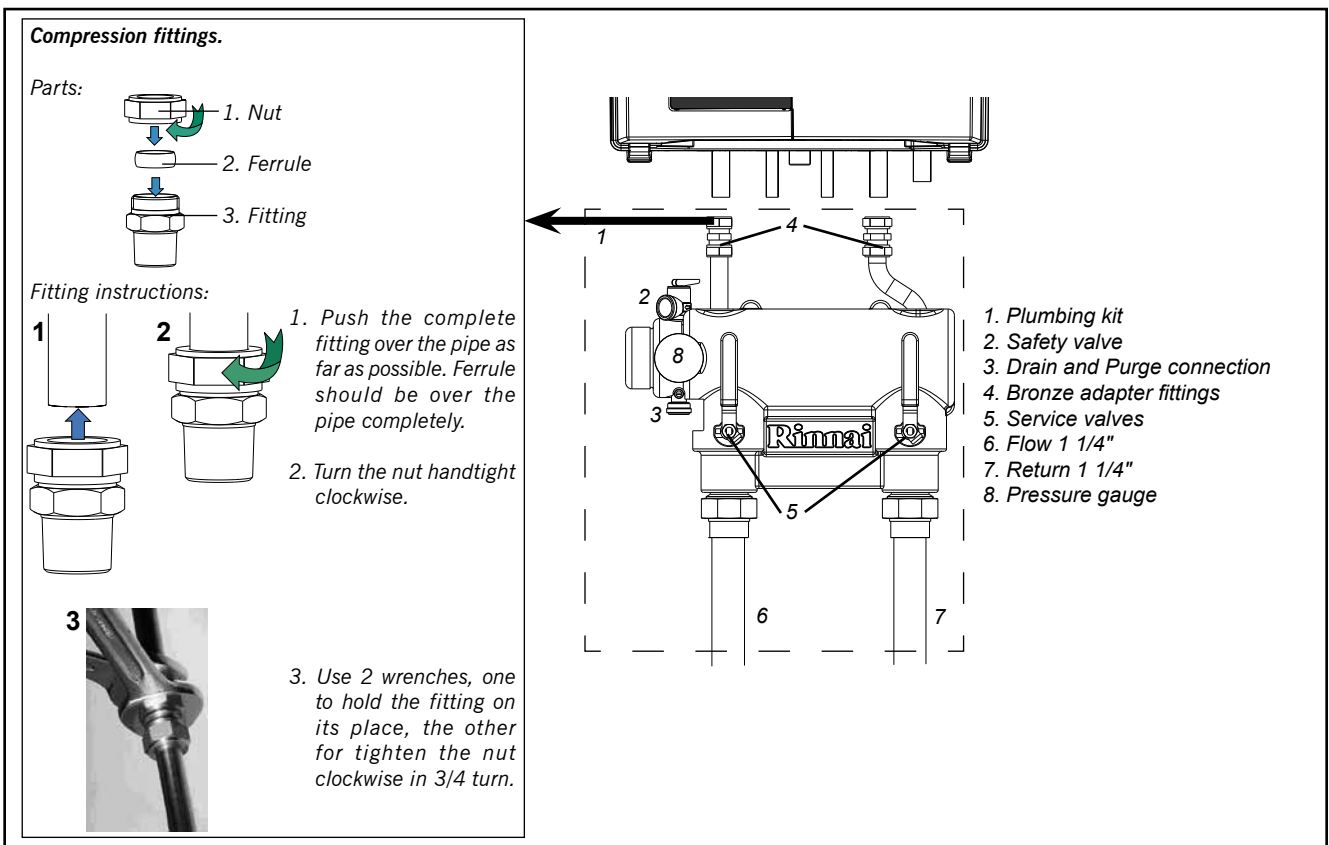

Plumbing Kit installation

fig. 6

- Boiler system flushing (Not Boiler heat exchanger)

When replacing an existing boiler the heating system should be flushed with the old boiler in place before the new boiler is added to the system. If the old boiler has already been removed a bypass must be piped in when the new boiler is installed in order to facilitate the flushing of the system.

The boiler must be valved off from the system, while the system is flushed. No system cleaner should ever enter the boiler heat exchanger because of its caustic nature it could damage the heat exchanger.

1. Close the shutoff valves on both the supply and return connections on the plumbing kit (V1 and V2).
2. Open the bypass valve (V4).
3. Connect pump outlet hose (H1) to the supply side purge station (BD1)
4. Connect drain hose (H3) to the return side purge station (BD2).
5. Pour the system cleaner into a pail and follow the system cleaner instructions about circulation time and volume to be added to the system.
6. Operate the charging pump (CP) and charge the system with the required volume of system cleaner
7. Close the supply side purge station (BD1)
8. Turn on the system pump(s) (SP) and circulate the cleaner through the system for required time by the cleaner manufacturer.
9. Once the time required by the system cleaner manufacturer has been met place the drain hose (H3) in a drain.
10. Turn off the system pump(s) (SP)
11. Close the main valve on the system return (V3) and open the return side purge station (BD2).

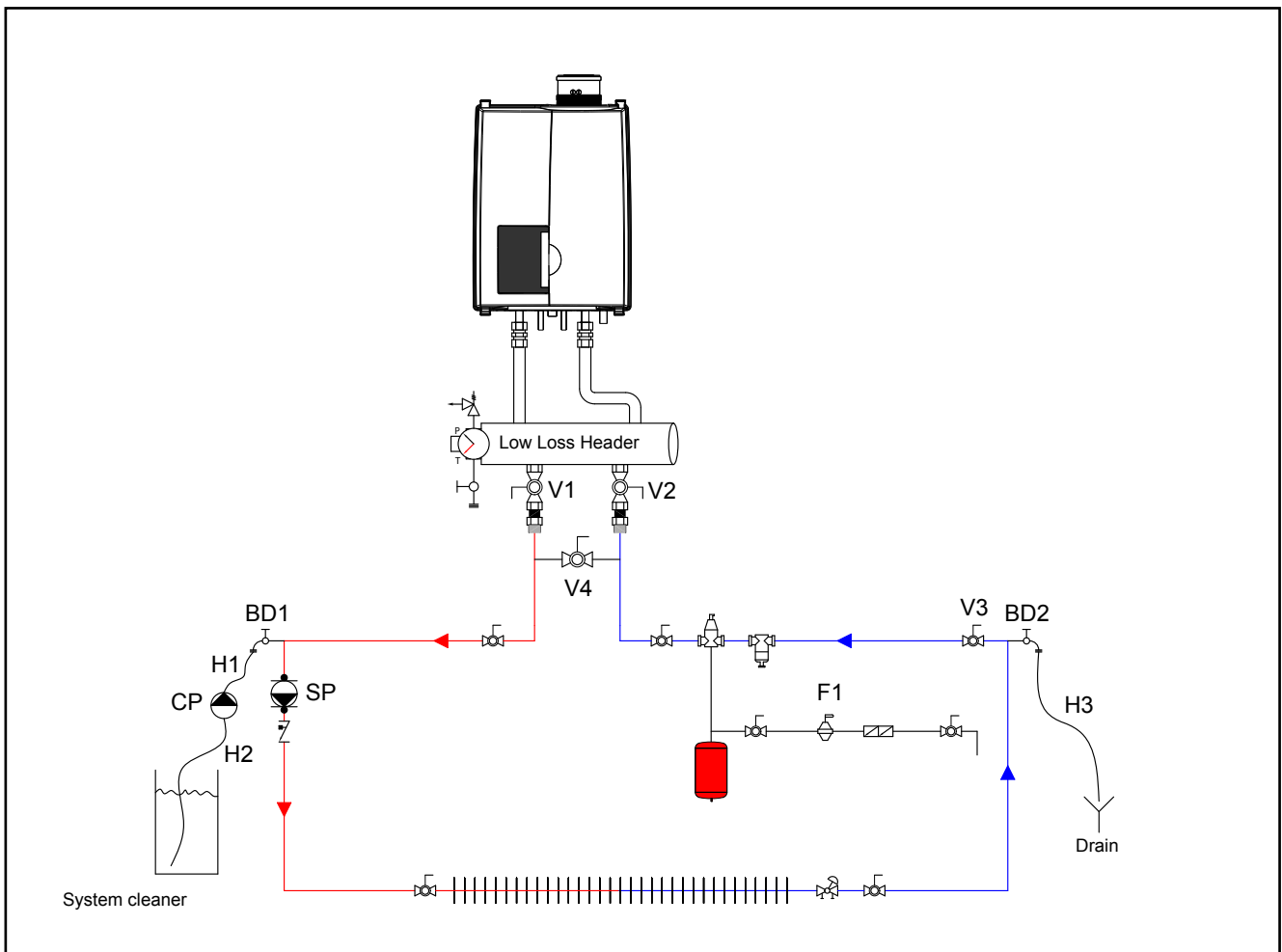

Boiler system flushing

fig. 7

12. Open the auto feed on the system (F1) and allow water to rinse the system for whichever is greater; 10 minutes or the required rinse time by the system cleaner manufacturer.
13. If the installation is a zone system be sure to purge out each zone individually
14. Close the auto feed on the system (F1)
15. Close the return side purge station (BD2) and disconnect the hose (H3).
16. Open the main valve on the system return (V3)
17. Close the bypass valve below the plumbing kit (V4).
18. Open shutoff valves on both the supply and return connections on the plumbing kit (V1 and V2).
19. Clean out the dirt trap
20. Test the pH of the water that will be used for filling the system
21. Test the water hardness of the water that will be used for filling the system
22. Use the proper water treatment to ensure the pH and water hardness are within the Rinnai boiler water quality guidelines
23. The boiler and system may now be filled.

The following is a list of approved system cleaners, inhibitors, and antifreeze.

Approved antifreeze:

- Rhomar RhoGard Mutli-Metal (AL safe)
- Noble Noburst AL

Approved system cleaner:

- Noble Noburst Hydronic System Cleaner
- Fernox F3 Cleaner
- Rhomar Hydro-Solv 9100

The system cleaners from NoBurst, Rhomar, and Fernox are NOT to be used in the boiler. The boiler must be closed off (valved off) from the rest of the system or not connected while the cleaners are in the system. The system should then be drained and then thoroughly flushed with clean water to remove all the system cleaner.

Approved inhibitors:

- Rhomar Pro-tek 922
- Noble Noburst AL inhibitor



NOTICE

- Connect the expansion tank to the system. See chapter 6.2.
- Connect the pipes so that they are free from strain.

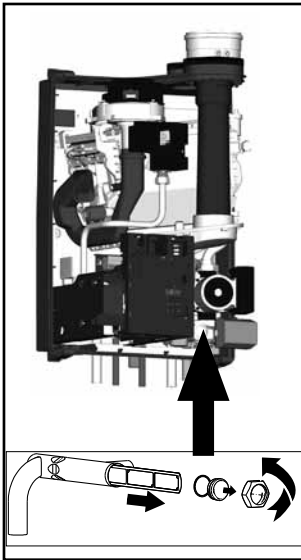

The boiler has a self-adjusting and self-protecting control system for the load and the pump capacity. By this means the temperature difference between the supply and return water is checked and controlled.

If the installation resistance is over the stated value; the load will be adjusted until an acceptable temperature difference between supply and return water has been obtained. If, after this, the temperature difference is still not acceptable then the boiler will switch off and wait until an acceptable temperature has arisen.

If an unacceptable temperature is detected, the control will repeatedly try to achieve water flow over the boiler. If not the boiler will switch off.

As standard the boiler is provided with a water filter in the return pipe of the boiler, so that debris of the central heating water is prevented from affecting the boiler.



NOTICE

The boiler is designed to be used on pressurized heating systems only.

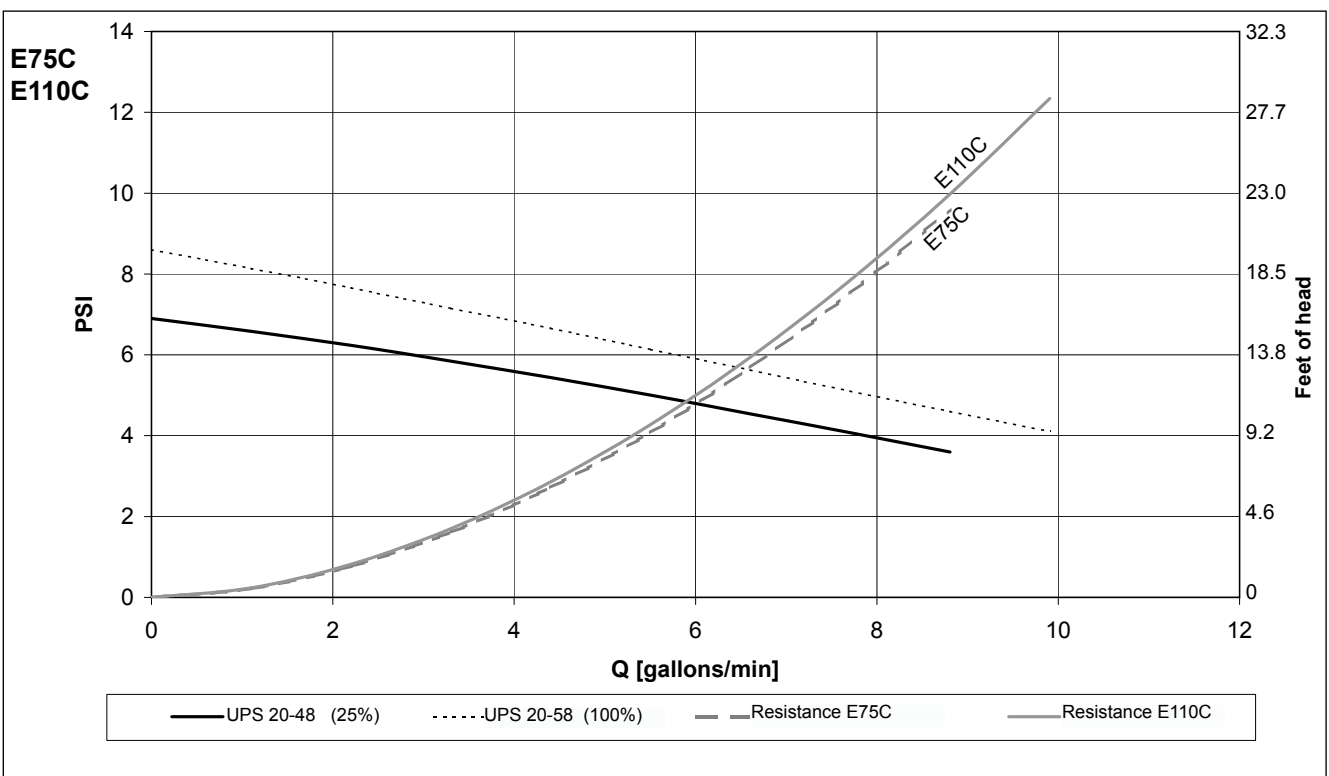

pump index lines

graph 1

6.1.2 Side mounting kit for the Low Loss header

A side mounting kit for the low loss header is available as an accessory. This kit relocates the low loss header from directly below the boiler to the left side of the boiler only. The kit includes all the parts required to relocate the low loss header including all mounting brackets and material. This kit provides an alternative to for installations with height limitations and allows for an alternative piping installation.

Kit 1 for boiler models E75C and E110C Rinnai part number: 804000071.

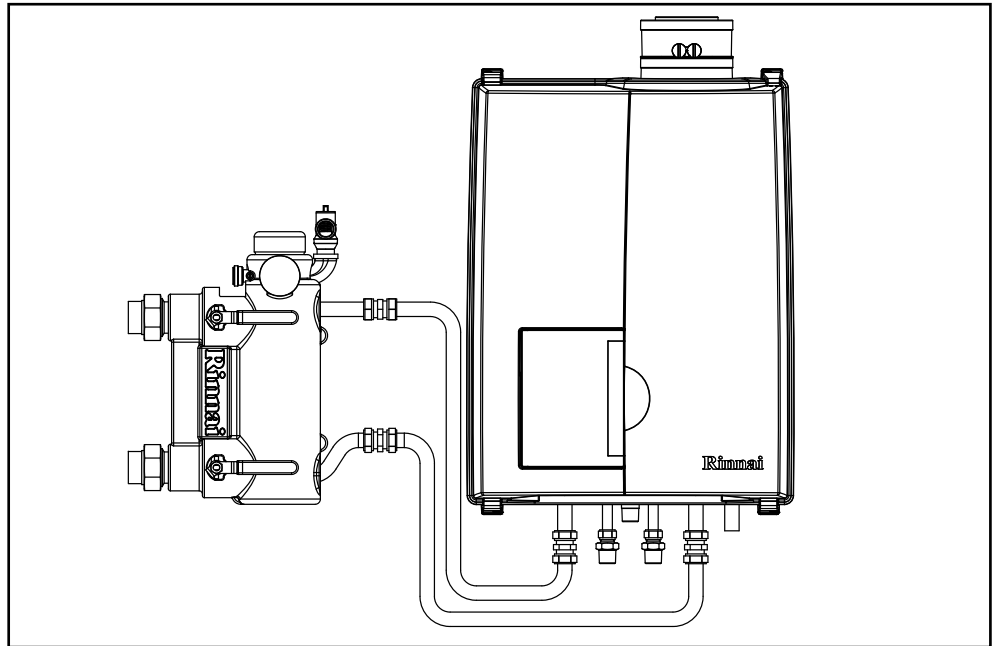

Side mounting kit

figure 9

6.1.3 Safety valve



NOTICE

An ASME 30 psi pressure relief valve is installed on the plumbing kit included with the boiler.

6.1.4 Low water cut off



NOTICE

The Rinnai E boiler has a factory installed pressure switch type Low Water Cut Off (LWCO). Check your local codes to see if a Low Water Cut Off is required (LWCO) and if this device conforms to local code. See the Rinnai Boiler Applications Manual for further information.

The Low water cut off is not serviceable.

6.2 Expansion tank

The E-Series boilers are equipped with an internal expansion tank. The tank of the E75CN and E75CP is positioned inside the boiler casing. This expansion tank has a pre-charge pressure of 14.5 PSI / 1 Bar and a capacity of 2.1 gallon / 8 litres.

The tank of the E110CN and E110CP is positioned directly beneath the boiler and together with the casing forms a single entity with the boiler.

The casing can be removed by pulling forwards. The expansion tank has a pre-charge pressure of 14.5 PSI / 1 Bar and a capacity of 3.1 gallon / 12 litres.

If a larger capacity expansion tank is needed for the installation a standard expansion vessel should be fitted additionally.

In that case choose an expansion tank volume, of which the summary is geared to the installation's water capacity. The pre-charge pressure depends on the installation height above the expansion tank. Fit the expansion tank into the return pipe as close as possible to the boiler. The extra expansion tank should be sourced locally. Please refer to the expansion tank manufacturer for further information.



NOTICE

Fill the expansion tank to a minimum of 14.5 psi.



NOTICE

The boiler cannot be used with an open type expansion tank.

6.3 Underfloor heating system (plastic pipes)

When using oxygen-permeable pipes, e. g. for underfloor heating systems, the system must be separated using plate heat exchangers.



NOTICE

No recourse can be made to the terms of the warranty in the event of failure to regard the regulations pertaining to plastic underfloor heating pipes.

6.4 Gas supply connection



DANGER

Only work on gas lines if you are licensed for such work.

If these instructions are not followed exactly, a fire or explosion may result causing property damage, personal injury or death.



WARNING

Rinnai wall mounted boilers are built to run on Natural Gas or Propane Gas. The gas type the boiler is suitable for is indicated on the packaging and on the boiler by a blue label with Natural Gas or a green label with Propane Gas and on the identification plate on the boiler.

First check the identification plate on the boiler for the suitable gas type.



DANGER

Do not use the boiler for another type of gas than indicated on the identification plate of the boiler. This will cause improper functioning and can damage the boiler.

Natural gas: resume with chapter 6.4.1

Propane gas: resume with chapter 6.4.2

6.4.1 Gas connection with natural gas

NOTICE

The gas supply connection must comply with local regulations or, if such regulations do not exist, with the National Fuel Gas Code, ANSI Z 223.1. For Canada, the gas connection must comply with local regulations or, if such regulations do not exist, with the CAN/CSA B149.1, Natural Gas and Propane Installation Code.

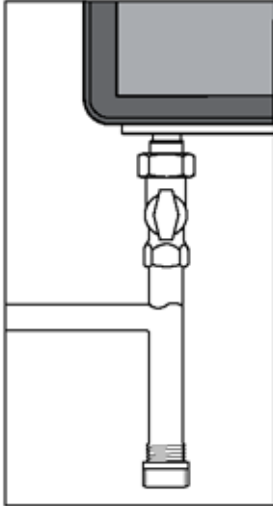

Sediment trap *figure 10*

Pipe sizing for natural gas

Contact gas supplier to size the gas supply line and meter.

Gas piping

A sediment trap must be installed upstream of the gas controls.

The boiler gas pipe is equipped with external 3/4" M-NPT thread, onto which the tail piece of the gas shut off valve can be connected. Use appropriate sealing.

The connection to the boiler must include a suitable method of disconnection and a gas control valve must be installed adjacent to the boiler for isolation purposes. The nominal inlet gas pressure measured at the boiler should be 7" W.C. (18 mbar) for Natural gas (Gas A). Maximum pressure with no flow (lockup) or with the boiler running is 10.5 inches W.C. Minimum pressure with the gas flowing (verify during boiler startup) is 4.0 inches W.C.

The gas pipe must be fitted to the gas valve free from any strain.

NOTICE

Make sure that the gas pipe system does not contain dirt, particularly with new pipes.

DANGER

Always check the safety of the gas pipe system by means of a bubble test using leak-search spray.

NOTICE

The boiler and its individual shut off valve must be disconnected from the gas supply piping system during any pressure testing of that system at test pressures in excess of 1/2 PSI (3.5kPa).

NOTICE

The boiler must be isolated from the gas supply piping system by closing its individual manual shutoff valve during any pressure testing of the gas supply piping system at test pressures equal to or less than 1/2 PSI (3.5 kPa).

6.4.2 Gas connection with propane gas

NOTICE

The gas supply connection must comply with local regulations or, if such regulations do not exist, with the National Fuel Gas Code, ANSI Z 223.1. For Canada, the gas connection must comply with local regulations or, if such regulations do not exist, with the CAN/CSA B149.1, Natural Gas and Propane Installation Code.

Pipe sizing for propane gas

- Contact gas supplier to size pipes, tanks, and 100% lockup gas pressure regulator.

Propane Supply Pressure Requirements

- Adjust propane supply regulator provided by the gas supplier for 14 inches W.C. maximum pressure.
- Pressure required at gas valve inlet pressure port:
 - Maximum 14 inches W.C. with no flow (lockup) or with boiler running.
 - Minimum 8 inches W.C. with gas flowing (verify during boiler startup).

Ensure that the high gas pressure regulator is installed at least 6 to 10 feet upstream of the boiler.

DANGER

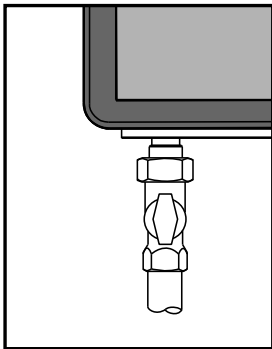

Gas shut off valve onto boiler
figure 10a

Gas piping

- Use a gas shut off valve compatible with propane gas.
- A sediment trap must be provided upstream of the gas controls.

The boiler pipe is equipped with external 3/4" M-NPT thread, onto which the tail piece of the gas shut off valve can be screwed. Use appropriate sealing.

The connection to the boiler must include a suitable method of disconnection. A gas control valve must be installed adjacent to the boiler for isolation purposes. The nominal inlet working gas pressure measured at the boiler should be 12 inch W.C. (30mbar) for Propane gas (Gas E).

The gas pipe must be fitted to the gas valve free from any strain.

Make sure that the gas pipe system does not contain dirt, particularly with new pipes.

NOTICE

Always check the safety of the gas pipe system by means of a bubble test using leak-search spray.

DANGER

The boiler and its individual shut off valve must be disconnected from the gas supply piping system during any pressure testing of that system at test pressures in excess of 1/2 PSI (3.5kPa).

NOTICE

The boiler must be isolated from the gas supply piping system by closing its individual manual shutoff valve during any pressure testing of the gas supply piping system at test pressures equal to or less than 1/2 PSI (3.5 kPa).

NOTICE

6.5 Hot water supply

Connection of the drinking water installation should be performed according to the national secondary drinking water regulations.



DANGER

Do NOT use toxic chemicals, such as those used for boiler treatment in potable water heating systems used for space heating.

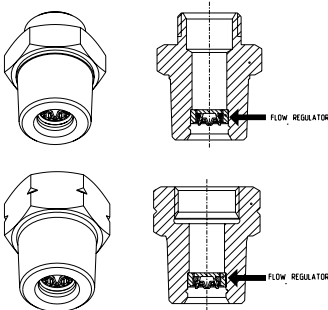

The sanitary water pipes can be connected to the installation by use of adapter fittings. The cold water inlet on the Combi boilers must be equipped with the following components (counted in the water flow direction):

Flow regulator valve (supplied), Safety group, Expansion vessel 87 PSI / 6bar (potable water, blue).

The 3/4" NPT adapter fitting with flow reducing valve must be fitted in the cold water connection.

A flow regulator valve is supplied with the boiler in a 3/4"NPT adapter fitting. The flow regulator valve ensures that a quantity of water is supplied which has a outlet temperature of 120°F (assuming a cold water temperature of 45°F). The quantity of water is virtually unaffected by the water pressure.

Identification colors flow regulators:
E75C: White
E110C: Green



NOTICE

When there is a water pressure lower than 22PSI / 1.5 bar it is advisable to remove the inside mechanism of the flow reducing valve.

6.5.1 Domestic Water quality

Appropriate steps must be taken to ensure the brazed plate heat exchanger does not become plugged by scale caused by hard water or sediment. If the plate heat exchanger becomes plugged by either scaling from hard water or sediment it is not the responsibility of Rinnai.

1. Water hardness for DHW

When there is a water hardness of more than 6 to 7 grains hardness is used for domestic water a water softener must be installed on the inlet side of the DHW connection.

2. Sediment in DHW

If there is sediment in your domestic water supply sediment filter or other suitable device should be used to remove it before the water enters the brazed plate heat exchanger.

6.5.2 Domestic water treatment Accessory

Rinnai offers a domestic water treatment device that can help reduce scale build up. This device can be installed on the incoming cold water line for any combi boiler. For additional information on contact Rinnai.

6.5.3 Installing a Thermostatic Mixing Valve

A thermostatic mixing valve should be installed on all E combi boilers on the domestic hot water side to prevent scalding. This valve will regulate the water temperature leaving the brazed plate heat exchanger. See the figure 10 for the suggest piping.

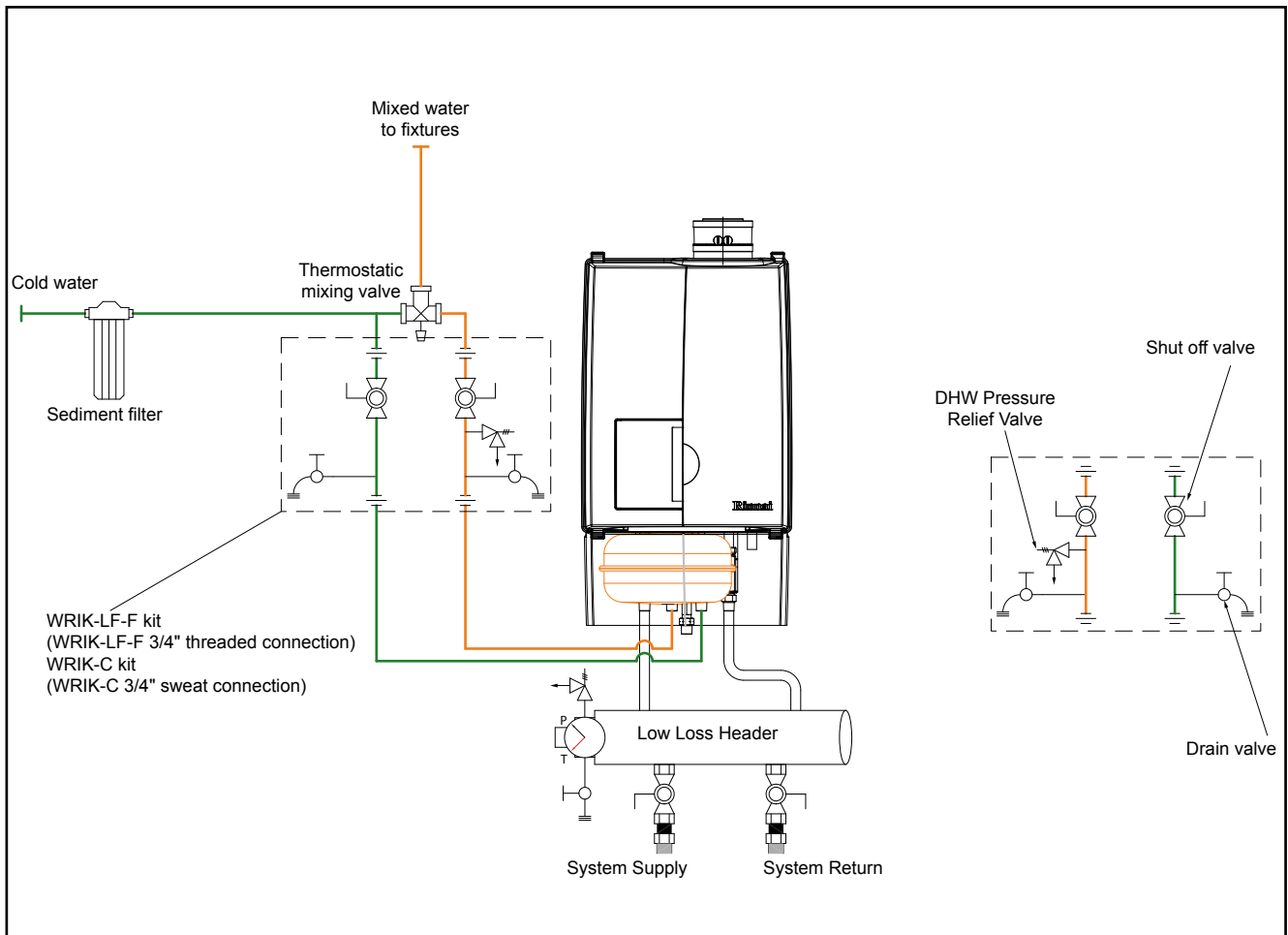

DHW piping with thermostatic mixing valve

fig. 11

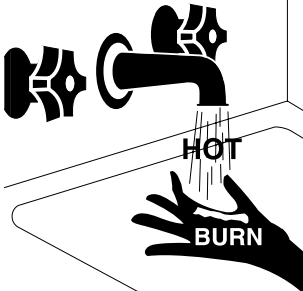
	<h3>DANGER</h3>	<p>Hot water can be dangerous, especially for infants or children, the elderly, or infirm. There is hot water scald potential if the thermostat is set too high.</p> <p>Water temperatures over 125° F (51° C) can cause severe burns or scalding resulting in death.</p> <p>Hot water can cause first degree burns with exposure for as little as:</p> <ul style="list-style-type: none"> 3 seconds at 140° F (60° C) 20 seconds at 130° F (54° C) 8 minutes at 120° F (48° C) <p>Test the temperature of the water before placing a child in the bath or shower.</p> <p>Do not leave a child or an infirm person in the bath unsupervised.</p>
		

6.5.4 Installing a valve kit

A means to isolate the domestic plate heat exchanger for cleaning must be provided at installation. Refer to figure 10 for proper piping layout. A Rinnai valve kit can be used on domestic water connections for all combi boilers to allow for cleaning of the plate heat exchanger and installation of the domestic hot water pressure relief valve.

- Rinnai recommends the use of the WRIK-LF-F (3/4" NPT thread connection) or WRIK-C kit (WRIK-C (3/4" sweat connection) when connecting the domestic water lines to the boiler
- Use of this kit will assist in flushing the flat plate heat exchanger in areas where water quality issues exist, as well as improve overall product serviceability

6.5.5 Pressure relief Valve

- An approved pressure relief valve is required by Rinnai for all water heating systems.
- The relief valve must comply with the standard for Relief Valves and Automatic Gas Shutoff Devices for Hot Water Supply Systems ANSI Z21.22 and/or the standard Temperature, Pressure, Temperature and Pressure Relief Valves and Vacuum Relief Valves, CAN1-4.4.
- The relief valve must be rated up to 150 psi and to at least the maximum BTU/hr of the appliance.
- The discharge from the pressure relief valve should be piped to the ground or into a drain system to prevent exposure or possible burn hazards to humans or other plant or animal life. Follow local codes. Water discharged from the relief valve could cause severe burns instantly, scalds, or death.
- The pressure relief valve must be manually operated once a year to check for correct operation.
- The relief valve should be added to the hot water outlet line according to the manufacturer instructions. DO NOT place any other type valve or shut off device between the relief valve and the water heater.
- Do not plug the relief valve and do not install any reducing fittings or other restrictions in the relief line. The relief line should allow for complete drainage of the valve and the line.
- If a relief valve discharges periodically, this may be due to thermal expansion in a closed water supply system. Contact the water supplier or local plumbing inspector on how to correct this situation. Do not plug the relief valve.
- Rinnai does not require a combination temperature and pressure relief valve for this appliance. However local codes may require a combination temperature and pressure relief valve.

6.5.6 Programming domestic hot water preheat

When plate warming is selected the brazed plate heat exchanger is kept warm and this reduces the wait time for domestic hot water by approximately 1 minute. When this setting is turned off the wait time for DHW is increased by approximately 1 minute.

NOTICE

If plate warming is selected consider the following.

This product is a domestic hot water priority boiler; therefore continuous flow in the DHW system (perhaps due to a leaky fixture) may cause the boiler to remain in DHW mode — thus preventing the heating system from adequately functioning. In the event the DHW system has a leak, this feature should be turned off until this problem can be corrected.

This selection can be done with the first digit of Parameter 36.
Domestic hot water preheat ON = 1x (Factory setting)
Domestic hot water preheat OFF = 2x
See chapter 10 how to change a parameter.

The domestic hot water preheat setting is designed to increase the comfort of the home owner and reduce water consumption by reducing the wait time for hot water at the fixture. This comfort setting will create a slight increase in the gas usage of the boiler, but this will be offset by the reduction in wasted water at the fixture.

6.6 Condensate drain pipe

This boiler produces condensate. Condensate must be drained otherwise the boiler will not function and can cause property damage.

The condensation drain pipe should be connected to a drain in the building by means of an open connection. By this means the possibility of drain gases effecting the boiler is prevented. The drain connection should have a minimum diameter of 1.3" / 32mm.

Install the condensation drain pipe according to the applicable local code.

If the condensate outlet of the boiler is lower than the public sewage system a condensate pump must be used.

The condensate produced by the boiler has a pH value between 3 and 4.

Install a neutralization unit if required by the local code. It is recommended, but not required to install a condensate neutralizer.

Rianni offers a condensate neutralizer designed to work with all boiler models. The condensate neutralizer kit comes with all the necessary fittings and mounting material. PVC pipe must be supplied by the installation contractor.

Rinnai part number: 804000074

NOTICE

Do not drain the condensation water to the external rain gutter because of the danger of freezing and blockage of the drain.

NOTICE

Before putting the boiler into operation fill the condensate trap with 1.27 cups / 300 ml of water. If the boiler will be installed in a high temperature installation such as baseboard with a supply temperature of 160°F or above, fill the condensate trap with vegetable oil instead of water.

NOTICE

Use materials approved by the authority having jurisdiction. In absence of such authority, PVC and CPVC pipe must comply with ASTM D1785, F441 or D2665. Cement and primer must comply with ASTM D2564 or F493. For Canada, use CSA or ULC certified PVC or CPVC pipe, fittings and cement.

NOTICE

Periodic cleaning of the condensate disposal system must be carried out. See the Rinnai Boiler Application Manual for further information and for a piping diagram for the condensate.

6.7 Vent system and air supply system

Provisions for combustion and ventilation air must be made in accordance with section, Air for Combustion and Ventilation of the National Flue Gas Code, ANSI Z223.1, or Sections 7.2, 7.3 of 7.4 of CAN/CGA B149.1, Installation Codes, or applicable provisions of the local building codes.

- Do not store chemicals near the boiler or in rooms where the air is being supplied to the boiler. **See the list on page 10.**
- Do not allow the flue gases of other appliances to enter the boiler.
- Keep cabinet free of moisture



NOTICE

In the event that the system has actuated to shut off the main burner gas, do not attempt to place the boiler in operation. Contact a qualified service agency.

6.7.1 Intake / Exhaust Guidelines

Refer to the specific instructions on your vent product for additional installation requirements.

- You must use vent components that are certified and listed with this model.
- Do not combine vent components from different manufacturers.
- Venting should be as direct as possible with a minimum number of pipe fittings.
- Avoid dips or sags in horizontal vent runs by installing supports per the vent manufacturer's instructions.
- Support horizontal vent runs every four feet and all vertical vent runs every six feet or in accordance with local codes.
- Vent diameter must not be reduced.
- The boiler is unsuitable to install on a common vent installation, see also chapter 19.
- Do not connect the venting system with an existing vent or chimney.
- Do not common vent with the vent pipe of any other water heater or appliance.
- Vent connections must be firmly pressed together so that the gaskets form an air tight seal.
- Refer to the instructions of the vent system manufacturer for component assembly instructions.
- If the vent system is to be enclosed, it is suggested that the design of the enclosure shall permit inspection of the vent system. The design of such enclosure shall be deemed acceptable by the installer or the local inspector.



NOTICE

If it becomes necessary to access an enclosed vent system for service or repairs, Rinnai is not responsible for any costs or difficulties in accessing the vent system. Warranty does not cover obtaining access to an enclosed vent system.

6.7.2a Examples vent and air supply systems (concentric)

Wall thickness for vent termination installation:
 Minimum: 100mm / 4"
 Maximum: 508mm / 20"

Examples wall terminals

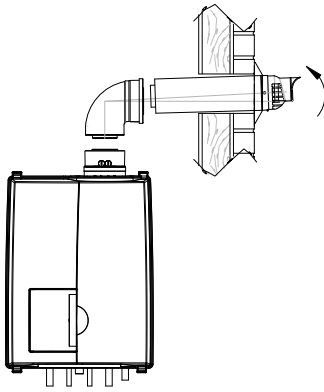

Short termination with wall terminal
 figure 12A

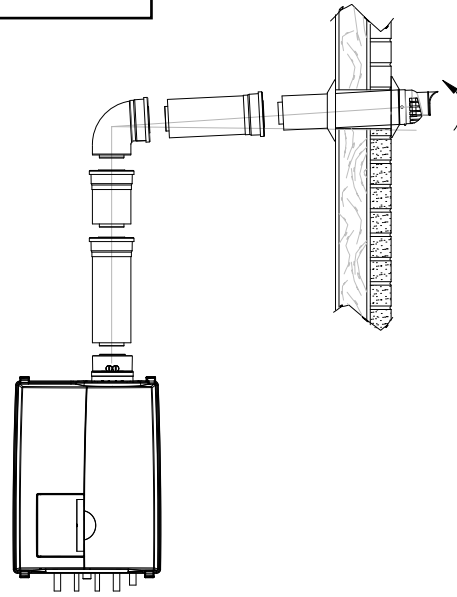

Termination with wall terminal on higher level
 figure 12B

Examples roof terminals

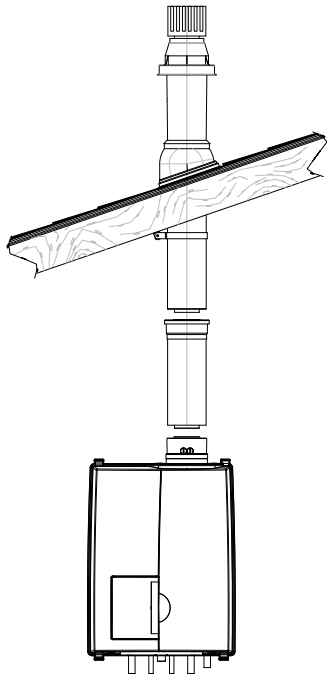

Short termination with roof terminal
 figure 12C

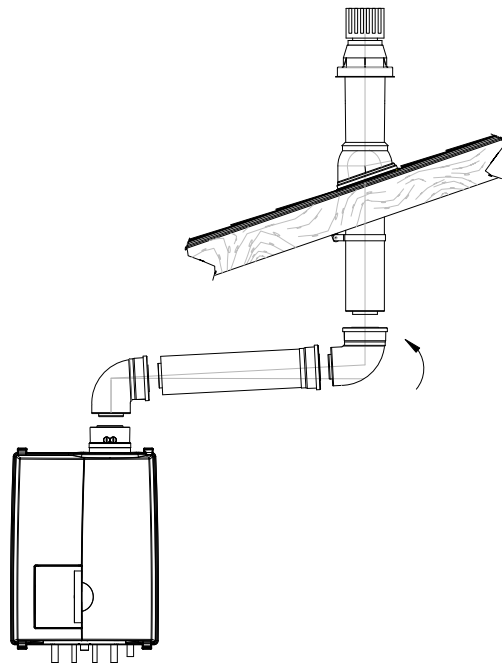

Termination with roof terminal and bends
 figure 12D

6.7.2b Examples vent and air supply systems (parallel)

Wall thickness for vent termination installation:
 Minimum: 100mm / 4"
 Maximum: 508mm / 20"

Examples sealed combustions

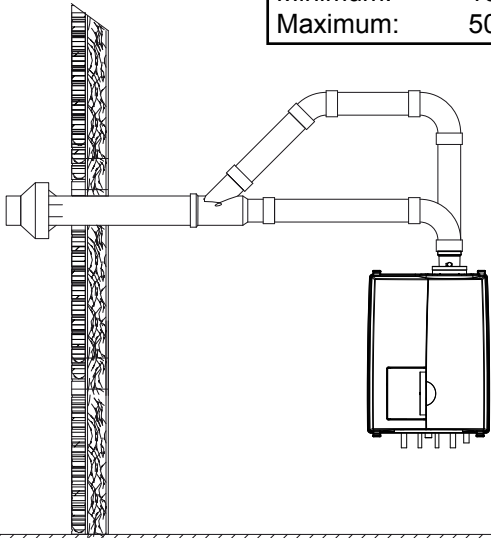

Horizontal with concentric termination figure 13A

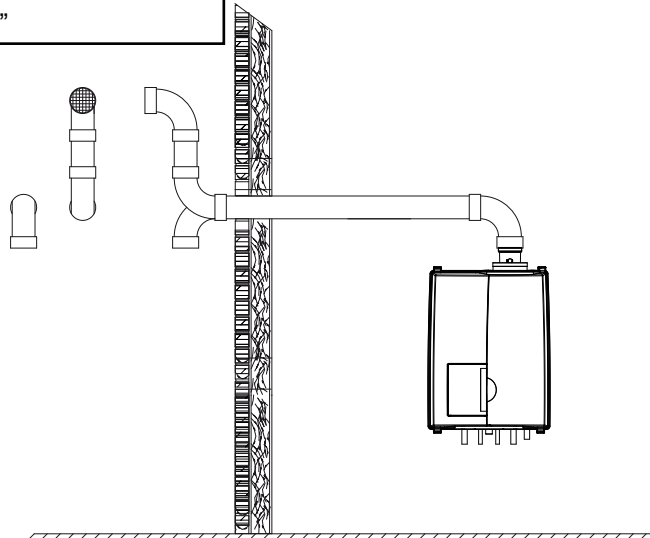

Horizontal with parallel termination figure 13B

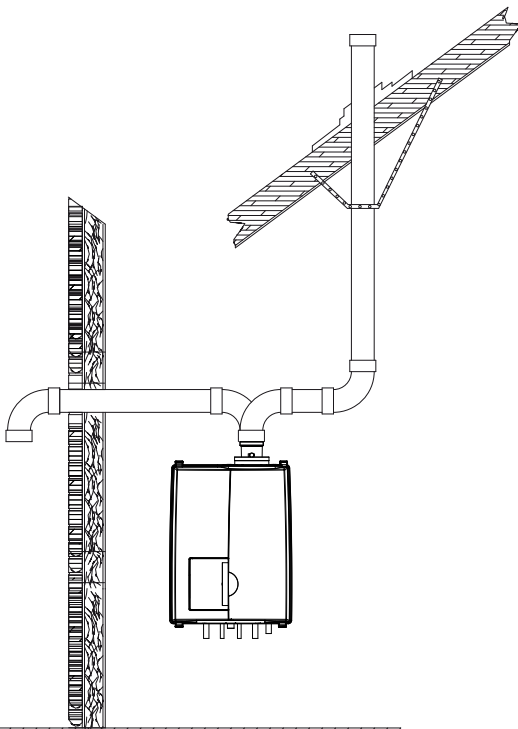

Vertical vent and horizontal air intake figure 13C

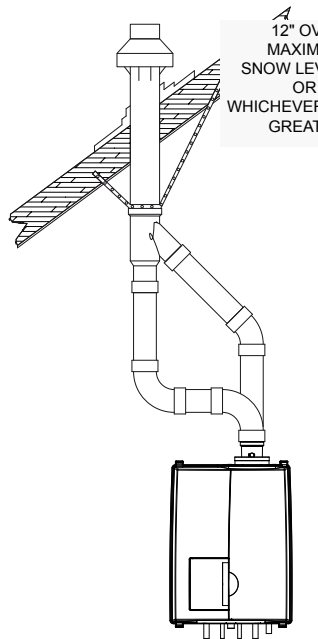

Vertical with concentric termination figure 13D

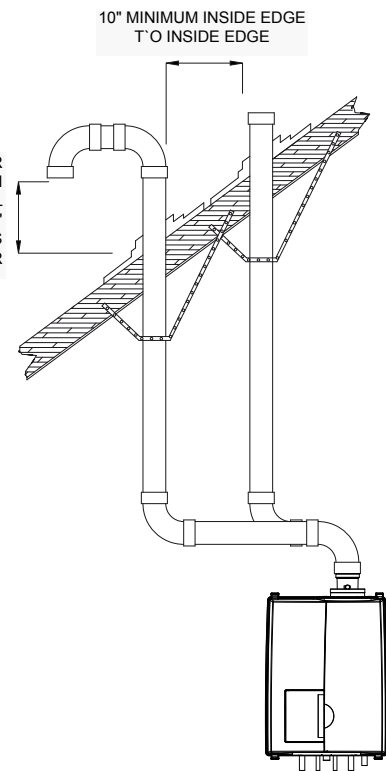

Vertical with parallel termination figure 13E

10" MINIMUM INSIDE EDGE
T'O INSIDE EDGE

12" OVER
MAXIMUM
SNOW LEVEL
OR 24"
WHICHEVER IS
GREATER

6.7.3 Installation of the vent system



NOTICE

Consult local and state codes pertaining to special building code and fire department requirements. Adhere to national code requirements.



NOTICE

Follow the listed maximum length of vent systems, which are boiler output dependent. The maximum permissible lengths are listed in table 9, chapter 6.7.6.

Decide how to install the exhaust and air intake system. You can choose between:

- **Concentric system (see chapter 6.7.2a)**

The concentric connection is provided standard initially.

The boiler concentric connection diameter is 3"/5" (80/125 mm), to which the venting and air supply system can be fitted, with or without elbow pieces. The maximum permissible pipe length is displayed in table 9, chapter 6.7.6.

- **Parallel system (see chapter 6.7.2b)**

The boiler can be converted to a parallel system with supplied adapters.

It is possible to use a parallel pipe connection of 2x 3". In this case a separate supplied kit, with 2 vent adapters 3" (ø80mm), cover 5" (ø125mm), vent exhaust pipe and gaskets should be fitted instead of the concentric vent adapter on top of the boiler. See chapter 6.7.3.1 for installation. The maximum permissible pipe length is set out in table 9, chapter 6.7.6.

- **Room Air System (outdoor combustion air)**

The boiler can use room air for combustion. If this option is selected the boiler must first be converted to the parallel system. A single exhaust pipe can then be fitted. It is required to use a room air filter (Part nr. 808000025) when using indoor air for combustion. See chapter 6.7.3.2 for installation. The maximum permissible pipe length is set out in table 9, chapter 6.7.6.



NOTICE

Rinnai strongly recommends the use of the room air filter in case of Room Air System (indoor combustion air).



NOTICE

When the boiler is installed in any of the areas listed in chapter 5.1, "Areas likely to have contaminants" or any area exposed to the contaminants listed in chapter 5.1, then sealed combustion is required.



NOTICE

We advise to install a vent system out of the venting system program supplied by Rinnai (See chapter 19 Parts list Vent system). For further information about the available components of the venting and air supply system we recommend you consult Rinnai and the Installation instructions and parts list documentation.

6.7.3.1 Boiler conversion from concentric to parallel

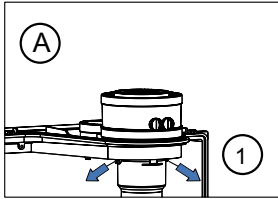

A. 1. Push the 2 clips slightly outwards

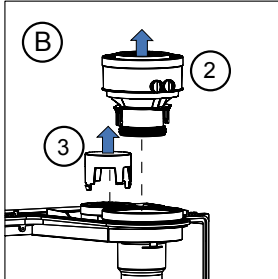

B. 2. Pull the concentric adaptor out of the boiler
3. Press the cover in the connection at the back from inside out

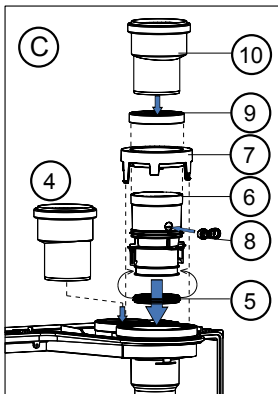

C. 4. Push the 3" adapter into the connection at the back of the boiler (= air intake)
5. Pull the rubber seal around the bottom of the exhaust connector
6. Push the exhaust connector in the boiler, in the boiler exhaust pipe until 'CLICK'
7. Push the 5" cover over the exhaust connector in the 5" opening until 'CLICK'
8. Push the rubber plug in open position in the O₂ measuring opening and close the stop.
9. Push the gasket around the top of the exhaust connector
10. Push the 3" exhaust adaptor in the exhaust connector.

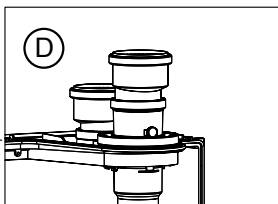

D. Connect the parallel vent system.

boiler conversion from concentric to parallel
figure 14a

6.7.3.2 Placing air filter

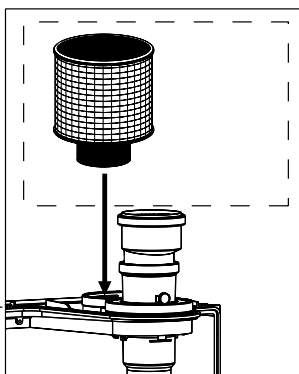

placing air filter on air intake
figure 14b

Push the air filter into the air intake on top of the boiler. See figure 14b.

The equivalent length of the combustion room air filter is 12ft (3.66m).
See Boiler Applications manual for additional venting information.

6.7.4 Recommended vent/air intake terminal position

Terminals should be positioned as to avoid products of combustion entering openings into buildings or other vents.

Maintain 12" of clearance above the highest anticipated snow level or grade or, whichever is greater. Please refer to your local codes for the snow level in your area.

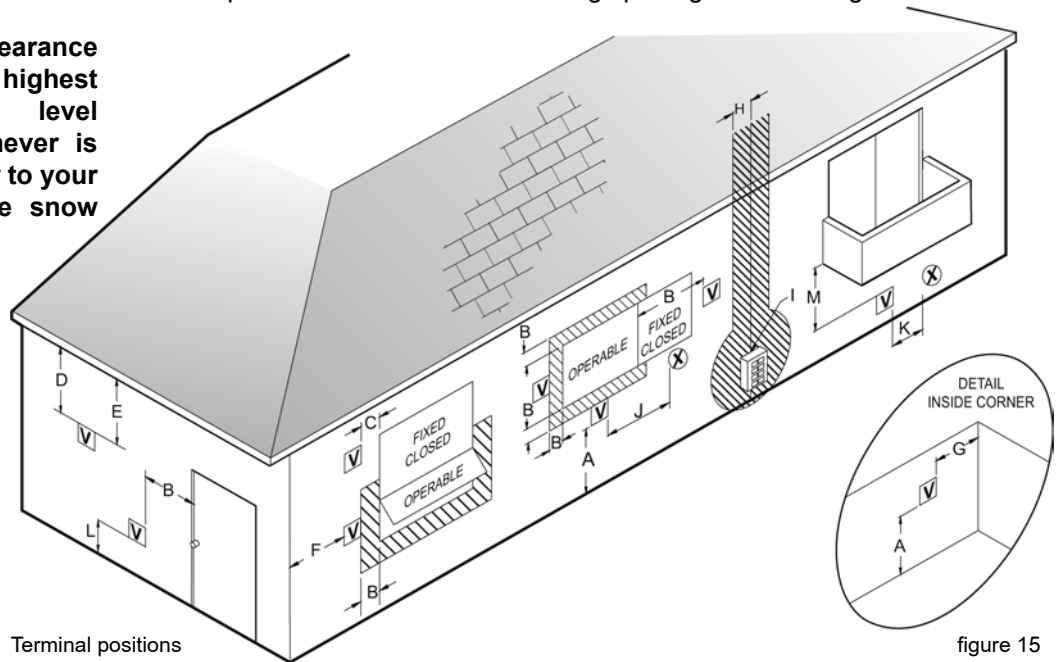

Terminal positions

figure 15

Ref	Description	Canadian Installations - Direct Vent and non Direct Vent	US Installations Direct Vent	US Installations non Direct Vent
A	Clearance above grade, veranda, porch, deck, or balcony	12 inches (30 cm)	12 inches (30 cm)	12 inches (30 cm)
B	Clearance to window or door that may be opened	6 inches (15 cm) for appliances ≤ 10,000 Btuh (3 kW), 12 inches (30 cm) for appliances > 10,000 Btuh (3 kW) and ≤ 100,000 Btuh (30 kW), 36 inches (91 cm) for appliances > 100,000 Btuh (30 kW)	6 inches (15 cm) for appliances ≤ 10,000 Btuh (3 kW), 9 inches (30 cm) for appliances > 10,000 Btuh (3 kW) and ≤ 50,000 Btuh (30 kW), 12 inches (91 cm) for appliances > 50,000 Btuh (30 kW)	4 feet (1.2 m) below or to side of opening; 1 foot (300 mm) above opening
C	Clearance to permanently closed window	*	*	*
D	Vertical clearance to ventilated soffit, located above the terminal within a horizontal distance of 2 feet (61 cm) from the center line of the terminal	*	*	*
E	Clearance to unventilated soffit	*	*	*
F	Clearance to outside corner	*	*	*
G	Clearance to inside corner	*	*	*
H	Clearance to each side of center line extended above meter/regulator assembly	3 feet (91 cm) within a height 15 feet (4.5 m) above the meter/regulator assembly	*	*
I	Clearance to service regulator vent outlet	36 inches (91 cm)	*	*
J	Clearance to nonmechanical air supply inlet to building or the combustion air inlet to any other appliance	6 inches (15 cm) for appliances ≤ 10,000 Btuh (3 kW), 12 inches (30 cm) for appliances > 10,000 Btuh (3 kW) and ≤ 100,000 Btuh (30 kW), 36 inches (91 cm) for appliances > 100,000 Btuh (30 kW)	6 inches (15 cm) for appliances ≤ 10,000 Btuh (3 kW), 9 inches (30 cm) for appliances > 10,000 Btuh (3 kW) and ≤ 50,000 Btuh (30 kW), 12 inches (91 cm) for appliances > 50,000 Btuh (30 kW)	4 feet (1.2 m) below or to side of opening; 1 foot (300 mm) above opening
K	Clearance to a mechanical air supply inlet	6 feet (1.83 m)	3 feet (91 cm) above if within 10 feet (3 m) horizontally	3 feet (91 cm) above if within 10 feet (3 m) horizontally
L	Clearance above paved sidewalk or paved driveway located on public property	7 feet (2.13 m) [1]	*	7 feet (2.13 m)









[1] A vent shall not terminate directly above a sidewalk or paved driveway that is located between two single family dwellings and serves both dwellings.

[2] Permitted only if veranda, porch, deck, or balcony is fully open on a minimum of two sides beneath the floor.

* For clearances not specified in ANSI Z223.1/NFPA 54 or CSA B149.1, clearances are in accordance with local installation codes and the requirements of the gas supplier.

clearances of venting system terminals

table 6

-  **NOTICE** See Boiler Applications manual for additional venting information.
-  **NOTICE** Terminals should be positioned as to avoid products of combustion entering openings into buildings or other vents.
-  **CAUTION** Maintain 12” of clearance above the highest anticipated snow level or grade or, whichever is greater. Please refer to your local codes for the snow level in your area.
-  **CAUTION** The termination shall be at least 4 feet (1,220 mm) for the US and 6 feet (1,830 mm) for Canada distance from electric meters, gas meters, regulators and relief equipment. (for room air application only)
-  **NOTICE** Horizontal vent systems should always be installed sloping towards the boiler (min. 21 mm/m, 1/4”/ feet), in order to avoid condensate retaining in the vent system. With the condensate running back to the boiler the risk of ice forming at the terminal is reduced.
-  **NOTICE** The whole route of the vent system must be installed upwards, never downwards, completely nor partly.
-  **NOTICE** Place pipe supports every 4 feet (1219 mm) of horizontal run, beginning with the support near the boiler to prevent movement in fittings and allow boiler to be free from any strain or weight on boiler or fittings.
-  **NOTICE** The terminal should be located where dispersal of combustion products is not impeded and with due regard for the damage or discoloration that might occur to building products in the vicinity (see fig 15 and 16).
-  **NOTICE** In certain weather conditions condensation may also accumulate on the outside of the air inlet pipe. Such conditions must be considered and where necessary insulation of the inlet pipe may be required.
In cold and/or humid weather water vapor may condense on leaving the vent terminal. The effect of such ‘water condensation’ must be considered.
The terminal must be located in a place not likely to cause a nuisance.

Use the Instructions of the Rinnai venting system for installation and service.

Cellular or Foam core PVC is not permitted for use with the boiler.

Item Description	Flue Material	Approval Codes for Installation	
		United States	Canada
Plastic Vent and/or air pipes and fittings	PVC Schedule 40	ANSI/ASTM D1785	ULC S636
	PVC - DWV	ANSI/ASTM D2665	
	CPVC Schedule 40	ANSI/ASTM F441	
Plastic Pipe cement and primer	PVC	ANSI/ASTM D2564	
	CPVC	ANSI/ASTM F493	

Item Description	Flue Material	Manufacturer	Approval code		Flue system
			US/CAN		
Stainless steel vent systems	Stainless Steel	Heat Fab	UL1738	Concentric twin pipe	Saf-T Vent SC Saf-T Vent EZ Seal
Stainless steel vent systems	Stainless Steel	Simpson Dura-Vent	UL1738 UL1738	Flexible liner Concentric twin pipe	FastNSeal Flex FastNSeal
Stainless steel vent systems	Stainless Steel	Ubbink			Rolux Condensing Vent System
Plastic Vent System	PPS	Ubbink			Rolux Condensing Vent System
Plastic Vent System	PVC/CPVC	IPEX	ULC S636		System 636

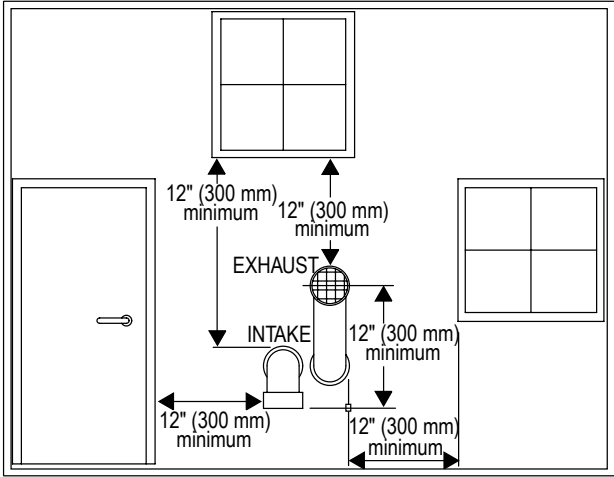

Terminal positions PVC

figure 16

Fittings or Piping Equivalent

	feet	m
45 degree elbow	3	0.91
90 degree elbow	6	1.83
plastic pipe per foot	1	0.30
concentric vent kit	5	1.52

Equivalent friction loss of PVC/CPVC table 8

6.7.5 Direct vent closet and alcove installation



WARNING

For closet and alcove installation, CPVC material, instead of PVC, must be used in a closet/alcove structure. Failure to follow this warning could result in fire, personal injury, or death.

Rinnai strongly suggests the use of concentric venting for all closet and alcove installations. For non direct vent room air applications see sections 6.7.6 and 6.7.9.

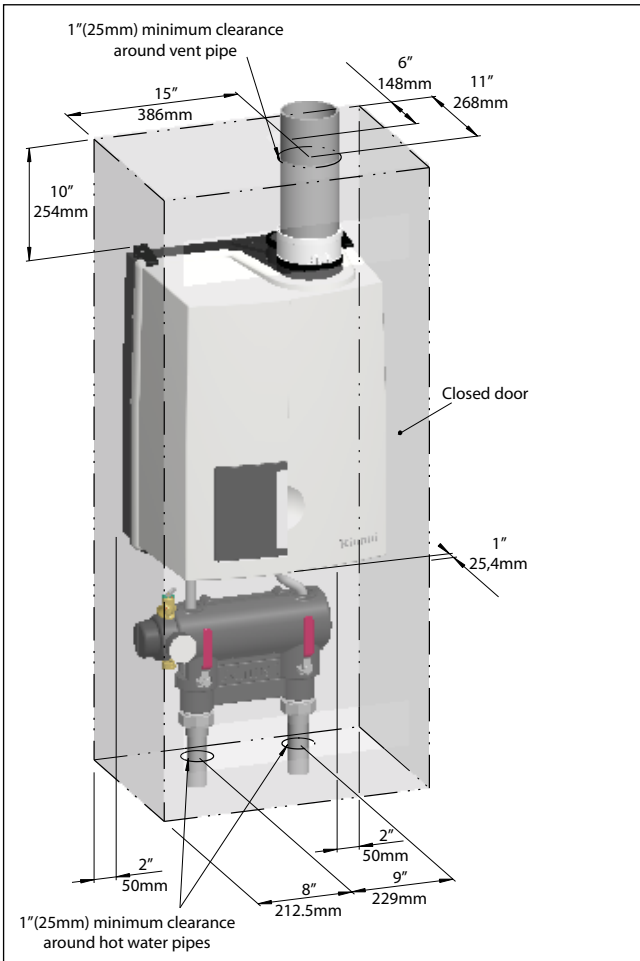

Closet installation

figure 21

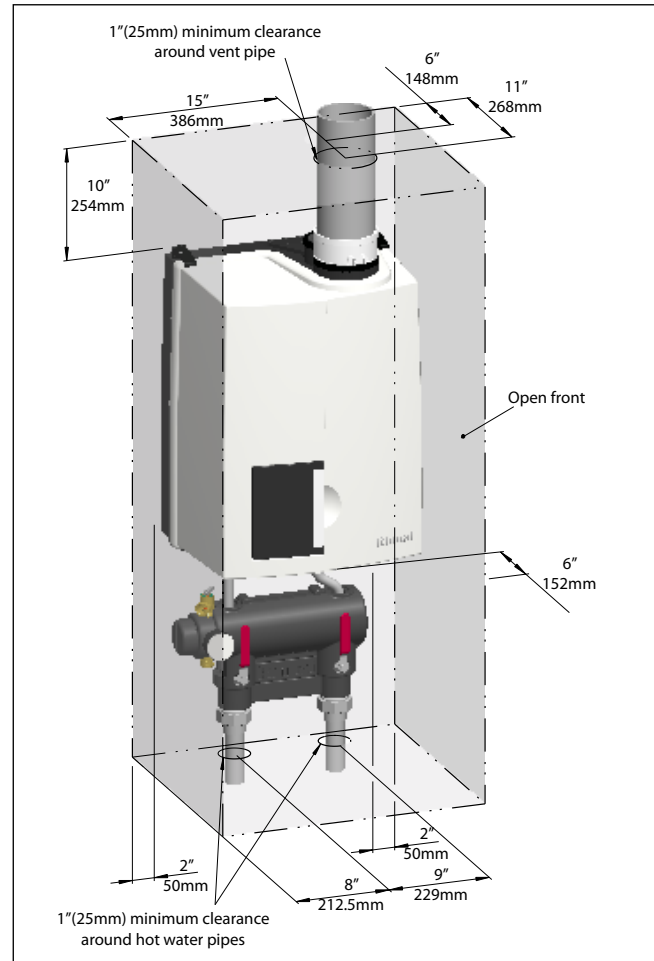

Alcove installation

figure 22

**DANGER**

The wall mounted boiler must be vented and supplied with combustion and ventilation air as described in this section.

Ensure the vent and air piping and the combustion air supply comply with these instructions regarding vent system, air system, and combustion air quality.

Inspect finished vent and air piping thoroughly to ensure all are airtight and comply with the instructions provided and with all requirements of applicable codes.

Failure to provide a properly installed vent and air system may cause severe personal injury or death.

**WARNING**

Use only the material listed in Rinnai's vent documentation for vent pipe, and fittings. Failure to comply could result in severe personal injury, death or substantial property damage.

**NOTICE**

Installation must comply with local requirements and with the National Fuel Gas Code, ANSI Z223.1 for U.S installations or CSA B 149.1 for Canadian installations.

**WARNING**

For closet and alcove installation, CPVC material (instead of PVC) must be used in a closet/alcove structure. Failure to follow this warning could result in fire, personal injury, or death.

**NOTICE**

All vent pipes must be connected and properly supported, and the exhaust must be pitched a minimum of a 1/4"/foot (21 mm/m) back to the boiler (to allow drainage of condensate). Please refer to the venting manufacturer's manual to see if a larger pitch is required for specific venting systems. The venting system manufacturer's required venting pitch must always be followed if larger than 1/4" (21 mm). Ubbink concentric condensing venting requires a pitch of 3/4"/foot (6mm/m).

**NOTICE**

Combustion air piping from the outside **MUST** must comply to the requirements of the authority having jurisdiction or, in the absence of such requirements, to the latest edition of the National Fuel Gas Code, ANSI Z223.1/NFPA 54. In Canada, installation must be in accordance with the requirements of CAN/CSA B149.1, Natural Gas and Propane Installation Code.

**NOTICE**

See the Rinnai Boiler Applications Manual for further information on venting.

6.7.7 Combustion air and vent piping lengths.

In the table below you find the maximum equivalent pipe length of the vent/air system based on 3" diameter. These lengths are for single pipe (room air), twin pipe, and concentric venting systems.

Boiler type	3" Max Vent equivalent length	3" Max Air equivalent length
E75	100 feet	100 feet
E110	100 feet	100 feet

Equivalent vent length

table 9

Calculation of equivalent length vent system

Choose the vent type and fill out the corresponding table.

* When determining equivalent combustion air and vent length, add 6 feet for each 90° elbow, 3 feet for each 45° elbow, 5 feet for the concentric terminal in the Parallel System, 2 feet for the concentric terminal in the Concentric System and 12 feet for the combustion room air filter .

Parallel system

Length tube	Number of elbows 90° x 6*	Number of elbows 45° x 3*	Concentric terminal Add 5 ft.*	Total	Multiply with factor	Equivalent length
Combustion air						
ft	ft	ft	ft	ft	0.5	ft
Vent						
ft	ft	ft	ft	ft	0.5	ft
Total equivalent length						<u>ft</u>

Concentric system

Length concentric tube, boiler to roof horizontal	Number of elbows 90° x 6*	Number of elbows 45° x 3*	Concentric terminal Add 2 ft.*	Total	Multiply with factor	Total equivalent length
ft	ft	ft	ft	ft	1.0	ft

Example of calculation:

Twin tube (parallel) with terminal

Combustion air length : 24 ft with elbow 3 x 90°

Vent length : 24 ft with elbow 2 x 90°, elbow 2 x 45°

Calculation:

Equivalent Air Length : $(24+3 \times 6+2) \times 0.5 = 23$ ft

Equivalent Vent Length : $(24+2 \times 6+2 \times 3+2) \times 0.5 = 23$ ft +Total = 46 ft.

6.7.8 Calculation of compensation factor

The compensation factor eliminates or reduces the natural effect of derate of maximum input caused by the resistance of the vent system and/or the impact of the altitude.

1. Determine the Compensation Factor Vent System CF(V) in the table below.

Eq. length (ft)		Boiler type	
min	max	E75	E110
		CF (V)	
0	10	0	0
11	20	0	0
21	30	0	2
31	40	1	4
41	60	2	6
61	80	3	8
81	100	4	10

Compensation factor vent system CP(V) table 10

2. Determine the Compensation Factor Altitude CF(A) in the table below.

Altitude (ft)		Boiler type
min	max	E75, E110
		CF (A)
0	1	0
1,000	2,000	6
2,000	3,000	12
3,000	4,000	18
4,000	5,000	24
5,000	6,000	30
6,000	7,000	36
7,000	8,000	42
8,000	9,000	48
9,000	10,000	54

Compensation factor altitude CP(A) table 11

NOTICE

Any application or installation above 10,000 must be reviewed by Rinnai's Engineering group. This is to ensure the product is installed and the overall system is designed properly and that the units are commissioned properly. Not involving of Rinnai's Engineering group would result in no support of the product and no warranty.

3. Calculate the Compensation Factor Total CF(T):

$$CF(T) = CF(V) + CF(A)$$

The result is the setting for Parameter 73.

Change parameter 73 according to this result. See Chapter 10.1 how to change parameters.

WARNING

Example of calculation:

E110

Eq. length vent system (taken from previous example)

Altitude

46 ft

7,200ft

CF(V) = 6

CF(A) = 42 +

CF(T) = 48

Parameter setting (Par. 73) = 48

Do not overcompensate the boiler by setting a higher value than calculated, otherwise the boiler could be seriously damaged.

6.7.9 Room Air System (indoor combustion air)

When using indoor air, Rinnai strongly recommends the use of an indoor air filter, P/N 80800025.

This boiler requires adequate combustion air for ventilation and dilution of flue gases. Failure to provide adequate combustion air can result in unit failure, fire, explosion, serious bodily injury or death. Use the following methods to ensure adequate combustion air is available for correct and safe operation of this water heater.

Important: Combustion air must be free of corrosive chemicals. Do not provide combustion air from corrosive environments. Appliance failure due to corrosive air is not covered by warranty.

Combustion air must be free of acid forming chemical such as sulfur, fluorine and chlorine. These chemicals have been found to cause rapid damage and decay and can become toxic when used as combustion air in gas appliances. Such chemicals can be found in, but not limited to bleach, ammonia, cat litter, aerosol sprays, cleaning solvents, varnish, paint and air fresheners. Do not store these products or similar products in the vicinity of this boiler.

Unconfined Space:

An unconfined space is defined in NFPA #54 "as a space whose volume is not less than 50 cubic feet per 1000 Btu/hr (4.8 m³ per kW per hour) of the aggregate input rating of all appliances installed in that space. Rooms communicating directly with the space in which the appliances are installed, through openings not furnished with doors, are considered a part of the unconfined space." If the "unconfined space" containing the appliance(s) is in a building with tight construction, outside air may still be required for proper operation. Outside air openings should be sized the same as for a confined space.

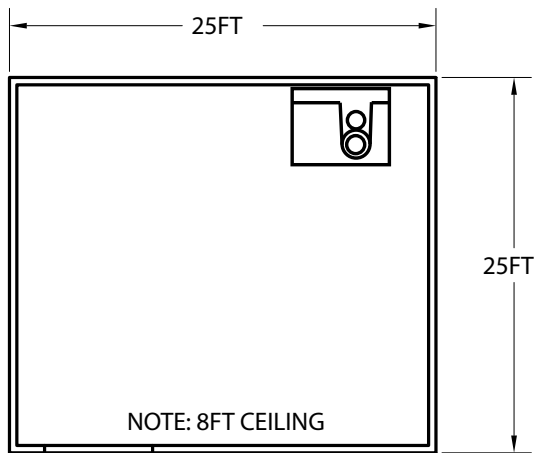

Unconfined Space

91,300 BTU Boiler

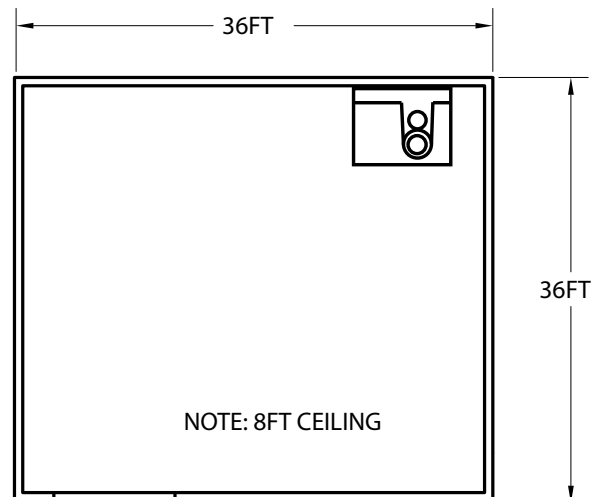

Unconfined Space

200,000 BTU Boiler

Unconfined space

figure 17

Confined Space:

(Small Room, Closet, Alcove, Utility Room, Etc.)

A confined space is defined in the NFPA #54 as "a space whose volume is less than 50 cubic feet per 1000 Btu/hr (4.8 m³ per kW per hour) of the aggregate input rating of all appliances installed in that space." A confined space must have two combustion air openings. Size the combustion air openings based on the BTU input for all gas utilization equipment in the space and the method by which combustion air is supplied:

- Using indoor air for combustion
- Using outdoor air for combustion

Louvers and Grills

When sizing the permanent opening as illustrated in figure 17, consideration must be taken for the design of the louvers or grills to maintain the required free area required for all gas utilizing equipment in the space. If the free area of the louver or grill design is not available, assume wood louvers will have 25% free area and metal louvers or grills will have 75% free area. Under no circumstance should the louver, grill or screen have openings smaller than 1/4".

Example:

Wood: 10 in x 12 in x 0.25 = 30 in²

Metal: 10 in x 12 in x 0.75 = 90 in²

Location

To maintain proper circulation of combustion air two permanent openings (one upper, one lower) must be positioned in confined spaces. The upper shall be within 12 inches of the confined space and the lower opening shall be within 12 inches of the bottom of the confined space. Openings must be positioned as to never be obstructed.

Combustion air provided to the appliance should not be taken from any area of the structure that may produce a negative pressure (i.e. exhaust fans, powered ventilation fans).

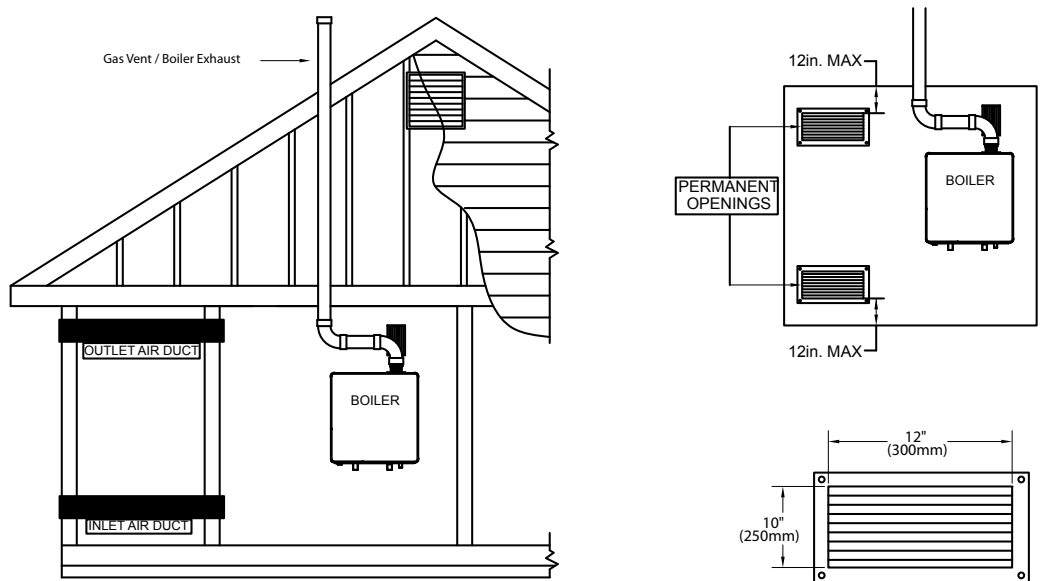

Louvers and grills

figure 18

Using Indoor Air For Combustion

When using air from other room(s) in the building, the total volume of the room(s) must be of adequate volume (Greater than 50 cubic feet per 1000 Btu/hr). Each Combustion air opening must have at least one square inch of free area for each 1000 Btu/h, but not less than 100 square inches each.

Using Outdoor Air For Combustion

Outdoor air can be provided to a confined space through two permanent openings, one commencing within 12 in. (300mm) of the top and one commencing within 12" (300mm) of the bottom, of the confined space. The openings shall communicate to the outside by one of two ways:

- directly through horizontal ducts
- indirectly through vertical ducts

When communicating directly with the outdoors through horizontal ducts, each opening shall have a minimum free area of 1 in²/2000 Btu/hr (1100 mm²/kW) of total input rating of all appliances in the confined space.

Note: If ducts are used, the cross sectional area of the duct must be greater than or equal to the required free area of the openings to which they are connected.

When communicating indirectly with the outdoors through vertical ducts, each opening shall have a minimum free area of 1 in²/4000 Btu/hr (550 mm²/kW) of total input rating of all appliances in the confined space. Combustion air to the appliance can be provided from a well ventilated attic or crawl space.

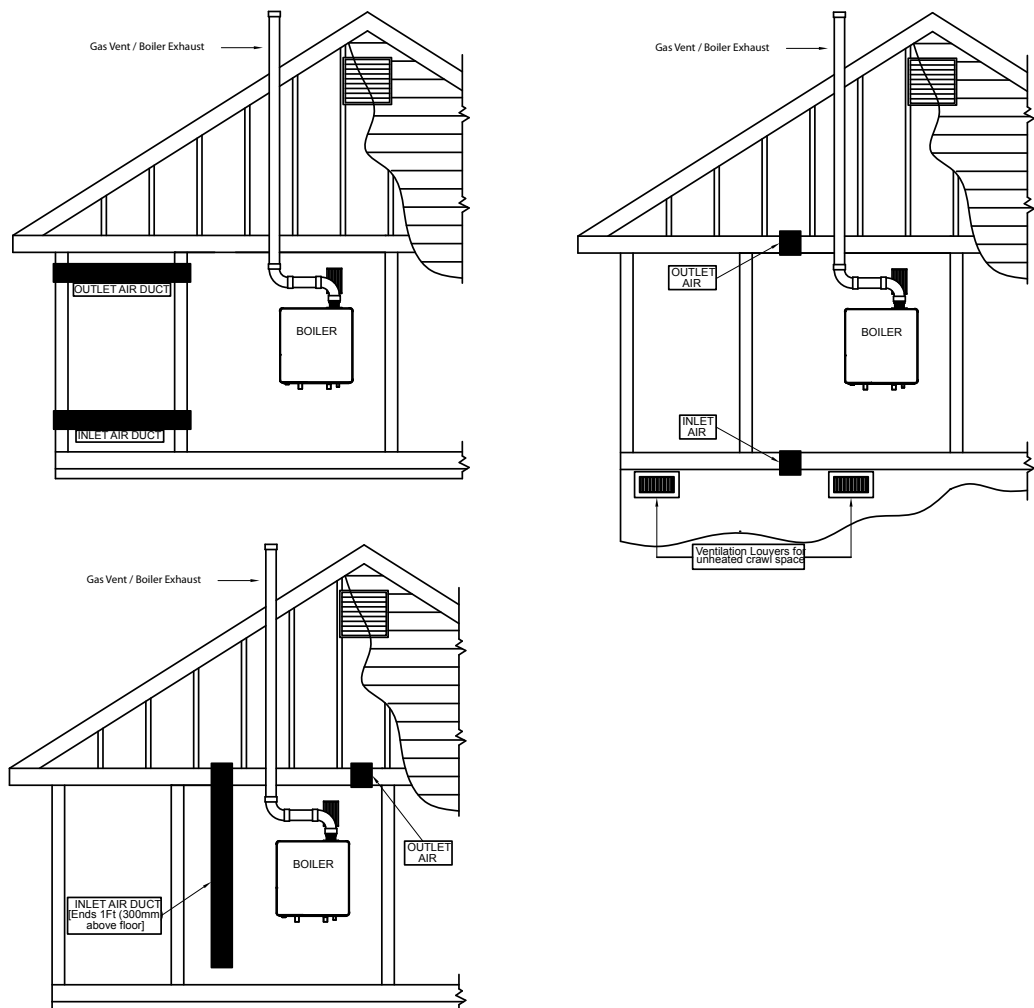

Louvers and grills

figure 19

7 Electrical connections

The electrical connections to the boiler must be made in accordance with all applicable local codes and the latest revision of the National Electrical Code, ANSI/NFPA-70. Installations should also conform with CSA C22.1 Canadian Electrical Code Part 1 if installed in Canada.

Devices such as, outdoor sensor, room thermostat or temperature control, and temperature sensor or thermostat are all connected to the internal connection terminal. The connection terminal is situated behind the Control Tower.

Connecting incoming power

Install a 120V main switch next to the boiler as service main switch of the boiler. Lead the cable through the back part of the boiler using a strain relief and lead the cable through the cable supports to the Control Tower. Use a step drill bit to create a knockout in the grey plastic cover of the boiler for a strain relief.

Connect a power supply cable to the cable harness terminal strip that connects to both the power switch on the front of the Control Tower and the terminal strip with positions 1, 2, and 3 on the inside of the Control Tower.



The boiler must be electrically grounded in accordance with local codes, or in absence of local codes, with the National Electrical Code, ANSI/NFPA 70 and/or the CSA C22.1, Electrical Code.



RISK OF ELECTRIC SHOCK.

Once the main power supply is on then there is 120V on terminals 1 to 12 if the main switch next to the boiler is switched on.



- **No changes may be made to the wiring of the boiler;**
- **All connections should be designed in accordance with the applicable regulations;**
- **Label all wires prior to disconnection when servicing controls. Wiring errors can cause improper and dangerous operation.**
- **Verify proper operation after operation servicing.**



NOTICE

The Rinnai room thermostat and controls must be connected to their allocated connections. All other types or makes of room thermostats or controls which are used must have a Volt free contact.

When using an on/off thermostat or control, it may be necessary to calibrate the anticipating resistance to prevent too high temperature fluctuations. As a standard rule this means mercury thermostats. This resistance wire is present in the Control Tower and must be connected to terminals 23 and 27. The anticipating resistance in the room thermostat has to be set at 0.11 A.

For more detailed questions regarding the components which are not supplied, the distributor should be contacted.



NOTICE

When wiring an RS100 it is suggested that a jumper be placed on terminals 22 and 23 so that in the event the control is damaged the boiler will still fire based on outdoor reset.

A jumper should also be used when commissioning or trouble shooting the boiler.



NOTICE

Power stealing thermostats cannot be connected to terminals 22 and 23.

Connection terminal E-Series																											
120 V~ Power supply			120 V~			120 V~			120 V~			8U.35.60.00	Cylinder connection three-way valve				DHW sensor	Outside sensor		Bus Controller		Room therm. On / Off		External safety contact		24 V~ 100 mA	
N	L		N	L		N	L		N	L			CH	DHW	N					A	B						
1	2	3	4	5	6	7	8	9	10	11			12	13	14	15		16	17	18	19	20	21	22	23	24	25
main power supply			120 Volts Rinnai only			120 Volts Rinnai only			120 Volts Rinnai only			internal or external three-way valve motor and tank sensor				ARV12 outdoor sensor		Bus room thermostat RS100		On/off thermostat or control (Volt free)		External safety contact					
CAUTION			CAUTION Terminals 4 to 11 are for Rinnai use only and not for use in any installation.																								

Connection terminal

figure 20

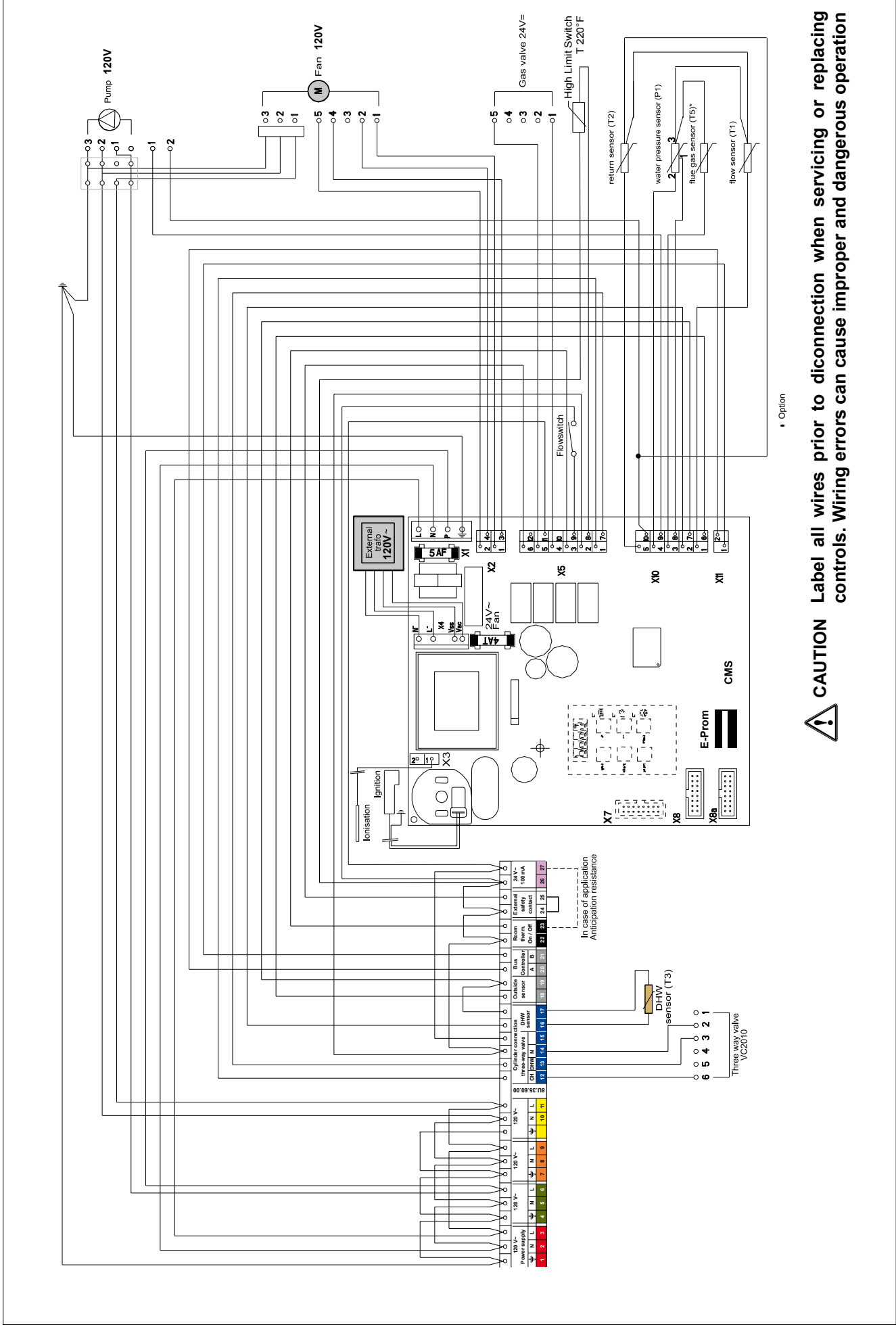

CAUTION Label all wires prior to disconnection when servicing or replacing controls. Wiring errors can cause improper and dangerous operation

electrical diagram

figure 21

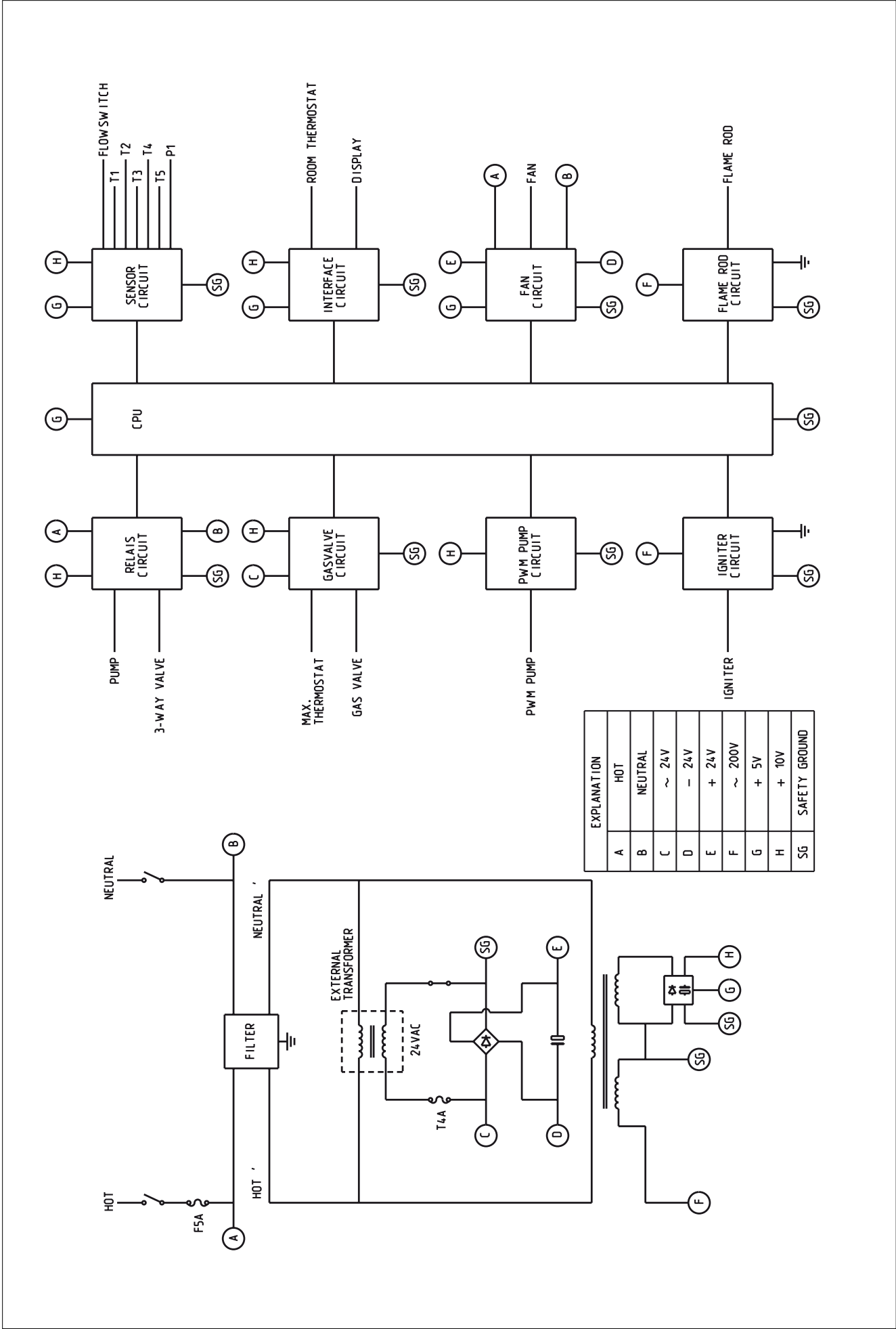

EXPLANATION	
A	HOT
B	NEUTRAL
C	~ 24V
D	- 24V
E	+ 24V
F	~ 200V
G	+ 5V
H	+ 10V
SG	SAFETY GROUND

figure 21a

The boiler is provided with a fully automatic microprocessor control, called CMS Control Management System. This control simplifies operation by undertaking all major control functions. Initially when power to the unit is switched on it will remain on standby. There is no indication LED on, until one of the program buttons is pressed. The control panel display will show the relevant state. When the installation is empty the display will show FILL.

The various parameters can be called up in two ways:

The Good-state or standard read out

The first way shows a simple display read out.

The boiler in operation will always show 'Good'. When a message is necessary this will be shown instead of Good.

Example

Technical read out

The second way is a technical read out. In normal situations the following will be shown:

- on the left the status in which the boiler is active;
- on the right the supply temperature in °F;

Alternately indicated by:

- the water pressure in the installation in PSI.

Example

When a message (error or blocking code) is necessary this will be shown instead of the technical read out.

NOTICE

**To switch over from the Good-state to the Technical read out (and vice versa):
- Press the STEP-button for 5 seconds.**

When the system has been filled the automatic de-aeration program starts, when a program has been selected, by pressing the button for Central Heating, DHW or pump program (, or). The program takes 17 minutes and stops automatically. After this the unit will function normally. (See also 'Filling and de-aerate the boiler and installation, chapter 9).

On a call for heating or hot water the control system will select the required water control temperature. This water temperature is called the T-set value. On a call for central heating the boiler ignites first at low input. The input is then changed slowly to match the load required. The boiler operates in this way to avoid excessive water noises and temperature overshoot. On a call for domestic hot water supply the T-set value of central heating return water temperature is monitored. Depending on the amount of domestic water which is withdrawn from the DHW facility, the central heating return water temperature, from which the input is adjusted, will vary.

Operation indication

(in the first display position by technical read out)

	No heat demand
	Fan pre/post purge
	Ignition phase
	Burner active on central heating
	Burner active on DHW
	Fan check
	Burner off when room thermostat is demanding
	Pump overrun phase for central heating
	Pump overrun phase for hot water
	Burner off because of too high flow temperature
	Automatic de-aeration program

8.1 Explanation of the function buttons

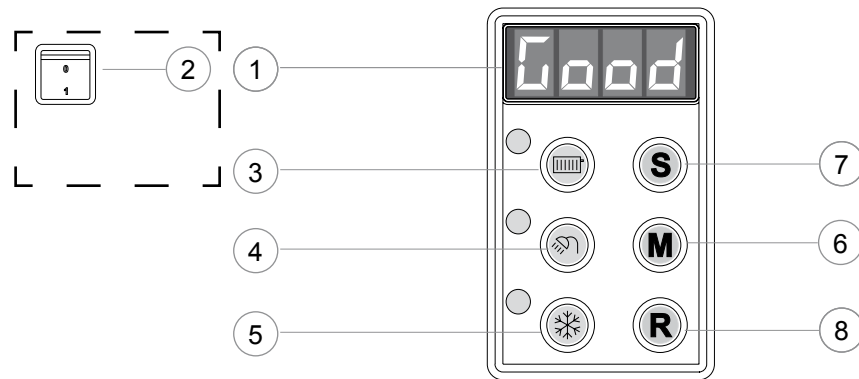

Boiler control panel

figure 22

NOTICE

Only qualified personnel who are trained for servicing these boilers are permitted to make alterations in the controller to calibrate the boiler to the installation.



1. **Display.** See previous page for further information.
2. **ON-OFF Switch (Placed separately next to the boiler)**
This switch turns the power supply to the boiler on or off.

CAUTION

Only turn the boiler off using this switch, when the burner is off..



3. **Central Heating program button.**
Switching the Central Heating on or off (LED on/off);



4. **Hot Water program button.**
Switching the Domestig Hot Water (DHW) facility on or off (LED on/off);



5. **Pump program button.**
adjusts the pump to continuous water circulation in the central heating system (LED on), or according to the pump overrun times on the relevant programs (LED off);

NOTICE

When the pump is switched on continuously it can lead to undesired heating up of the central heating system during the summer.

6. **Mode-button.**
*After briefly pressing, a selection of the data chapters can be retrieved.
After pressing for 5 seconds it is possible to enter the code as described in chapter 11.3;*
7. **Step-button.**
*After briefly pressing, the water pressure can be retrieved and pages per chapter can be retrieved.
After pressing for 5 seconds it switches from the Good-state to technical read out and vice versa;*
8. **Reset-button.**
After briefly pressing, for:
- unlocking errors;
- ending the access code;
After pressing for 5 seconds an operating stop is made, for example, for activating the automatic venting program.

Some buttons have other functions. These functions are only active when according to the procedure described in chapter 10, adjustment has to be changed or data must be retrieved from the CMS. The other functions are:

3. Central Heating program button : + function;
4. Hot Water program button: - function;
5. Pump program button : store-function, which means that by means of this button a modified setting is confirmed; scrolling in a data chapter.
7. Step-button:

**CAUTION****CAUTION**

Observe the following rules of safety:

- All work on the unit must take place in a dry environment.
- Rinnai units may never be in operation without their housing, except in connection with maintenance or adjustments (see Chapter 12 and 13).
- Never allow electrical or electronic components to come into contact with water.

**NOTICE****NOTICE**

Carry out the following tasks in connection with maintenance, etc. to an already-installed unit:

- Shut down all programs
- Close the gas shut off valve
- Shut off the power at the main power switch
- Close the service valves (system supply and return)

NOTICE

Take note of the following when maintenance or adjustments are needed:

- The unit must be able to function during these activities; for this reason, the unit's supply voltage, gas pressure and water pressure must be maintained. Ensure that this is not a source of potential danger during these activities.

**NOTICE****WARNING**

Following maintenance or other activities; always check the installation of all parts through which gas flows (with bubble test using leak-search spray).

9.1 Requirements of the water system

Before filling the heating system, the complete system, including all zones, must be thoroughly cleaned and flushed to remove sediment. Flush until clean water runs free of sediment. Rinnai suggests using an approved system cleaner to flush the system, but not the boiler. Always use Rinnai approved antifreezes. See the list at the end of this chapter. Never use reverse osmosis, D.I., or distilled water for filling the heating system.

**WARNING**

Do not use petroleum-based cleaning or sealing compounds in the boiler system. Damage of seals and gaskets in boiler and system could occur, resulting in substantial property damage.

The central heating installation needs to be filled with potable water.

**WARNING**

Use only potable water or approved glycol for filling the heating system. When the water hardness of the filling water exceeds > 10.5 gpg (200 mg/L) and the volume of the installation > 20L/kW (5.2 gallons/3,412 BTU) the water has to be treated until below the maximum value of 10.5 gpg (200 mg/L). The pH value of the installation water must be between 6.5 and 8.5.

Check the pH value using proper equipment or by having the water analyzed by a water treatment company.

If pH differs from above, contact Rinnai engineering for further assistance.

**NOTICE**

Failure to adhere to the water quality requirements will void the warranty.

Freeze protection

Freeze protection for new or existing systems must use glycol that is specially formulated for this purpose. This includes inhibitors, which prevent the glycol from attack the metallic components. This should be for multi-metallic components. Make certain to check that the system fluid is correct for the glycol concentration and inhibitor level. The system should be tested at least once a year and as recommended by the producer of the glycol solution. The allowed maximum concentration is 50%.



NOTICE

Use only Rinnai approved inhibitors. See below for an approved list of inhibitors.



WARNING

Use only inhibited propylene glycol solutions, which are specially formulated for central heating systems. Ethylene glycol is toxic and can attack gaskets and seals used in the boiler and system. Approved glycols are listed below.



NOTICE

Additives in the installation water are not permitted.

Approved antifreeze: • Rhomar RhoGard Mutli-Metal (AL safe)
(max. concentration 50%) • Noble Noburst AL

Approved system cleaner: • Noble Noburst Hydronic System Cleaner
• Fernox F3 Cleaner
• Rhomar Hydro-Solv 9100



NOTICE

The system cleaners from NoBurst, Rhomar, and Fernox are not to be used in the boiler. The boiler must be closed off (valved off) from the rest of the system or not connected while the cleaners are in the system. The system should then be drained and then thoroughly flushed with clean water to remove all the system cleaner.

Approved inhibitors: • Rhomar Pro-tek 922
• Noble Noburst AL inhibitor

9.2 Filling the heating system



For filling or topping off the installation you use the filling loop according to the following procedure:

1 Switch on the power supply;

FILL

2 The display will show FILL;



3 All functions off (heating , DHW  and pump 



4 Push briefly the 'STEP'-button: P XX (XX = water pressure in PSI);

5 Open the filling loop (Indication on display increases);

P 22

6 Fill up slowly to 16 to 18 PSI;

STOP

7 STOP appears on the display;

8 Close the filling loop;

9 De-aerate the complete installation, start at the lowest point;

10 Check the water pressure and if necessary top it up;

11 Close the filling loop;



12 Activate the functions in use (heating , DHW  and/or pump 

A XX

13 If A XX appears on the display, wait for 17 minutes;

14 Check the water pressure and if necessary top it up to 16 to 18 PSI

15 Close the filling loop;



16 Press the 'STEP'-button;

17 Be sure that the filling loop is closed.

A XX

Good 0 XX

18 After the automatic de-aeration program (A XX) is finished the boiler will return to the Good state or Technical read out.

Check the water pressure regularly and top off the installation when necessary. The working pressure of the installation should be between 16 and 18 PSI when the system is cold.



NOTICE

It can take a while before all air has disappeared from a filled installation. Especially in the first week noises may be heard which indicate the presence of air. The automatic air vent in the boiler will remove this air, which means the water pressure can reduce during this period and therefore topping off with water will have to be done.

During normal use the following messages can occur with the necessary follow up:

FILL

Water pressure is too low (<10 PSI), FILL indication remains continuously visible, the boiler is taken out of operation. The installation needs to be topped off.



Water pressure is too low (<12 PSI), flashing FILL will alternate with indication of water pressure, boiler power of 50% is possible. The installation needs to be topped off.

HIGH

Water pressure is too high (>42 PSI), if HIGH indication remains continuously visible, the boiler is taken out of operation. The installation pressure needs to be decreased by draining water.

9.3 Hot water supply

Apply the water pipe pressure to the DHW facility (open main valve and/or stop valve of the safety group).

Vent the DHW facility and the hot water installation by opening a hot water shut off valve. Leave the shut off valve open for as long as required until all air has disappeared from the DHW facility and the pipes and only water is flowing from the shut off valve.

FOR YOUR SAFETY READ BEFORE OPERATING



WARNING: If you do not follow these instructions exactly, a fire or explosion may result causing property damage, personal injury or loss of life.

- A. This appliance does not have a pilot. It is equipped with an ignition device which automatically lights the burner. Do **NOT** try to light the burner by hand.
- B. **BEFORE OPERATING** smell all around the appliance area for gas. Be sure to smell next to the floor because some gas is heavier than air and will settle on the floor.

WHAT TO DO IF YOU SMELL GAS

- Do **NOT** try to light any appliance.
 - Do **NOT** touch any electrical switch.
 - Do **NOT** use any phone in your building.
 - Immediately call your gas supplier from a neighbor's phone. Follow the gas supplier's instructions.
 - If you cannot reach your gas supplier, call the fire department.
- C. Use only your hand to push in or turn the gas control knob. Never use tools. If the knob will not push in or turn by hand, don't try to repair it, call a qualified service technician. Force or attempted repair may result in a fire or explosion.
- D. Do not use this appliance if any parts have been under water. Immediately call a qualified service technician to inspect the appliance and to replace any part of the control system and any gas control which has been under water.

OPERATING INSTRUCTIONS

1. **STOP!** Read the safety information above this label.
2. Turn off all electrical power of the appliance.
3. Set the thermostat or other operating control to the lowest setting.
4. This appliance is equipped with an ignition device which automatically lights the burner. Do **NOT** try to light the burner by hand.
5. Close main gas shut off valve. 
6. Wait (5) minutes to clear out any gas. Then smell for gas. Including near the floor.
If you smell gas, **STOP!** Follow "B" in the safety information above on this label.
If you don't smell gas, go to the next step.
7. Open main shut off valve. 
8. Set the thermostat or other operation control to desired setting.
9. Turn on all electric power to the appliance.
10. If the appliance will not operate, follow the instructions "To Turn Off Gas To Appliance" and call your service technician or gas supplier.

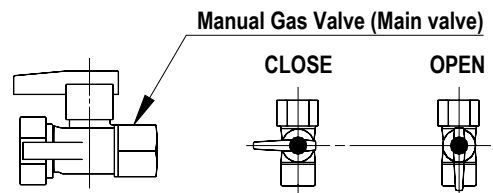

TO TURN OFF GAS TO APPLIANCE

1. Turn off all electric power to the appliance if service is to be performed.
2. Set the thermostat or other operating control to the lowest setting.
3. Close main gas shut off valve. 

8U.34.01.00 / 05.09

10 Adjustments

When the boiler is installed the software has already been pre-programmed at the factory. All software adjustments of the boiler control are already pre-programmed for a heating system with radiators/convectors with a supply temperature of 176°F. The adjustments are described in the Parameter chapter on the following page.

In certain cases parameters have to be altered in case of :

- Lower supply temperature
- High altitude/long vent length
- Minimum supply temperature



CAUTION

The venting / altitude calculation must always be performed during commissioning of the boiler.

Read through the Parameter chapter to adjust the boiler to its installation. Contact Rinnai in case of doubt.



NOTICE

Only qualified personnel who are trained for servicing these boilers are permitted to make alterations in the controller to calibrate the boiler to the installation.

10.1 Altering adjustments

STEP 1 Press the Mode-button for 5 seconds.

The display shows COdE followed by an arbitrary number;

STEP 2 Press by means of the + or the - button until the code C123 is shown;

STEP 3 Press the STORE-button to confirm the code (code blinks 1 x).

Now you have access to the installer level. There are 4 chapters:

- **PARA** Parameters
- **INFO** Information chapter (no adjustments possible)
- **SERV** Service chapter
- **ERR** Error-chapter (no adjustments possible)

The content of the chapters is described on the following pages.

STEP 4 Press briefly the MODE-button to select one of the 4 chapters, i.e. PARA;

STEP 5 Press briefly and release the STEP-button to select a Parameter
(parameter visible on the left, value on the right) ;

STEP 6 Alter the value, if necessary/possible, by means of the + or the - button

STEP 7 Press briefly on the STORE-button to confirm the alteration.

When you have to change more values, repeat from step 5.

STEP 8 Press once or more on the MODE-button until StBY or Good is shown:

After a few seconds the text StBY will be replaced by the technical read-out or Good-state (Depending from the position the access code is entered)

When you want to return from an arbitrary position to the original read out press once or more on the MODE-button until StBY is shown.



NOTICE

If no single button is used within 20 minutes the display will return automatically to its original read-out (Good state or technical read out)

Parameter Mode			
PARA	FACTORY	DESCRIPTION	RANGE
1	176°F	maximum supply temperature CH	68 - 176°F
2*	00	type of CH installation:	00 - 04
		No pre-selection made.	00
		Radiators, air heating, or convectors: T max. supply 176°F K factor heating curve 2.3; gradient 10°F/min; gear differential 10°F	
			01 DO NOT USE
		radiators with large surface areas or underfloor heating as additional heating: T max. supply 158°F K factor heating curve 1.8; gradient 10°F/min; gear differential 10°F	02
		under floor heating with radiators as additional heating: T max. supply 140°F; K factor heating curve 1.5; gradient 8°F/min; gear differential 8°F	03
		full under floor heating: T max. supply 122°F; K factor heating curve 1.0; gradient 6°F/min; gear differential 6°F	04
3	max.	maximum power CH in kW (.. x3415 = .. BTU/hr)	min-max
4*	00	control principal with on / off thermostat:	
		100 % on / off thermostat	00
		constant water circulation 22&23 closed contact day curve operation, open contact night curve operation	01
5*	2.3	heating curve K-factor (see also heating curve graph)	0.2 - 3.5
6*	1.4	heating curve exponent (see also heating curve graph)	1.1 - 1.4
7*	14°F	heating curve climate zone (see also heating curve graph)	-4 - 32°F
10*	0°F	fine adjustment heating curve day temperature	-8 to 10°F
11*	0°F	fine adjustment heating curve night temperature	-8 to 10°F
14	10°F/min.	gradient speed °F/min.	0 - 28°F/min.
15*	00	Booster after night decrease*:	
		no	00
		yes	01
23	26°F	Frost Temperature	-4 to 50°F
27	32°F	Minimum T-set CH	0 - 158°F
36	10	Type of three way valve and DHW facility	
		VC 2010 / VC 8010	x0
		Warming function plate heat exchanger ON	1x
		Warming function plate heat exchanger OFF	2x
43	max.	Maximum power DHW in kW (.. x3415 = .. BTU/hr)	min-max
49	100%	Maximum pump capacity heating	100 %
73	0	Altitude and venting CFT. See chapter 6.7.7	0 - 100
89	00	Address	
		No function	-01
		Bus thermostat	00
90	01	Display reading	
		°C and Bar	00
		°F and PSI	01

Info Mode			
INFO	FACTORY	DESCRIPTION	RANGE
1	°F	supply water temperature T1	
4	°F	return water temperature T2	
5	°F	DHW temperature T3	
7	°F	outdoor temperature T4	
8	°F	flue gas temperature T5 (optional sensor)	
16	%	actual power in %	
17	kW	actual power in kW (.. x3415 = .. BTU/hr)	
18	kW	actual load in kW (.. x3415 = .. BTU/hr)	
20		indication bus communication	
21	GJ	consumption total in GJ (.. x 33 = .. m3)	
22	GJ	consumption CH in GJ (.. x 33 = .. m3)	
23	GJ	consumption DHW in GJ (.. x 33 = .. m3)	
24	h	total number of burner run hours	
25	h	number of burner run hours CH	
26	h	number of burner run hours DHW	
32	h	total number of hours counter	
37	h	total number of run hours pump CH and DHW	
46	h	within how many hours is service required	

Service Mode			
SERV	VALUE	DESCRIPTION	RANGE
1	OFF	boiler in operation with burner function on	OFF - max.
2	OFF	fan adjustable and burner off	OFF - max.
3	OFF	pump adjustable with burner on	OFF - max.
4	OFF	showroom position ON = active and OFF = non active	ON - OFF

Error Mode		
ERRO	VALUE	DESCRIPTION
Err.L - Err.5		
Last saved error until 5 last previous errors		
1		error code
2		operation status boiler
3	°F	supply water temperature T1
4	°F	return water temperature T2
5	kW	load (.. x3415 = .. BTU/hr)
6	%	pump capacity

Parameter-, Info-, Service- and Error-chapters

Table 12



NOTICE

* Most of the data in this table can be requested by the RS100. Most of the adjustments which are stated in this table are unnecessary when in combination with the Rinnai RS100 thermostat and will be taken care of by the RS100 itself and do not have to be adjusted. For further information regarding to the RS100 thermostat refer to the Rinnai RS100 installation manual.

Outdoor reset

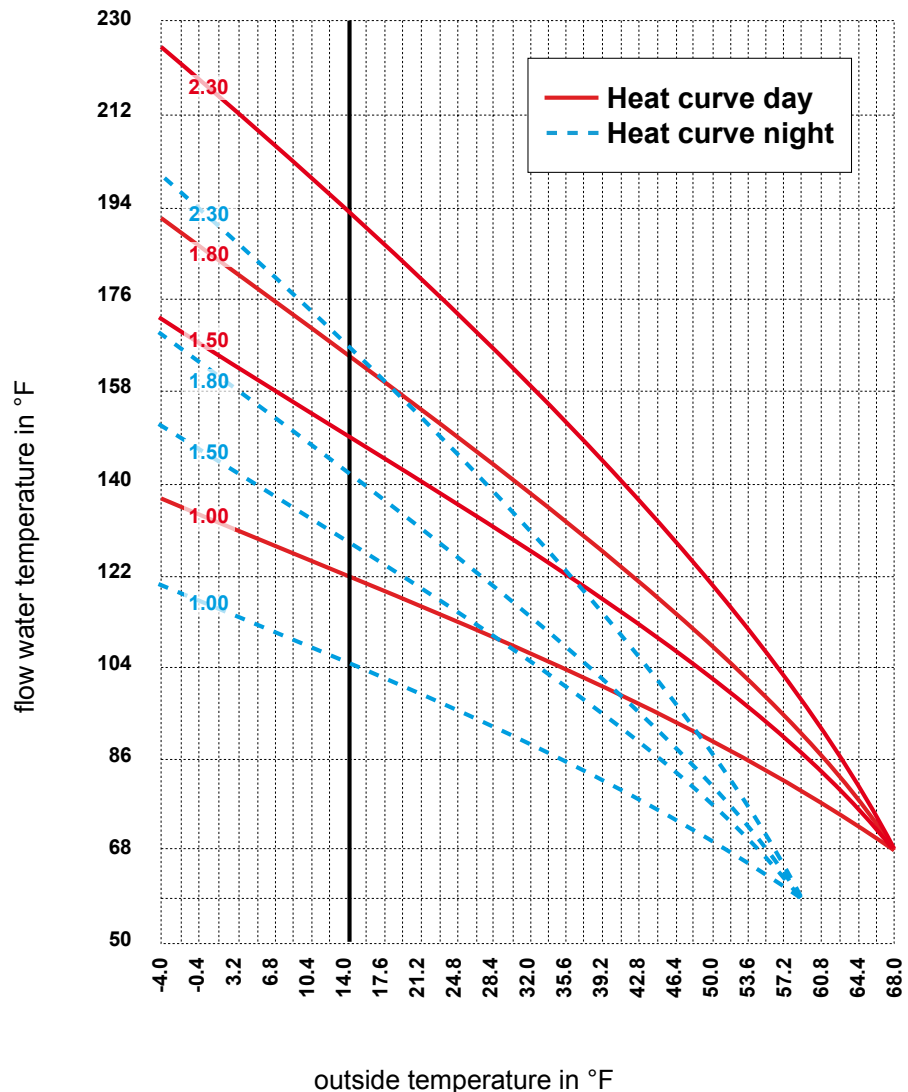

heating line adjustments Parameter Step 6 and 7

graph 2

10.2 Activating factory settings (green button function)

To activate the factory settings again please follow the next procedure (Note: all altered adjustments will be set back to their original factory settings that are accessible in the current service level the boiler is in either user or 123):

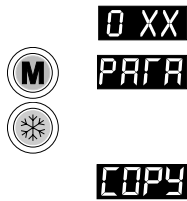



- Select, when necessary, the technical read out;
- Select with the MODE-button chapter PARA;
- Press the STORE-button.

The word "Copy" will appear and the factory settings are active again.

11 Isolating the boiler



Some situations require turning the entire boiler off.

By switching off the three buttons with the LED's for central heating, hot water and pump program ( ,  or ), the boiler is switched off. Do not shut off the power of the boiler, which means the circulation pump and the three-way valve are activated once every 24 hours in order to prevent these parts from seizing up.



CAUTION

In the event of frost danger during an isolated boiler it is advisable to drain the boiler and/or the installation.

12 Commissioning

NOTICE

Work on the boiler must be carried out by a competent person, using correctly calibrated instruments with current test certification.

These installation instructions are intended for professional installers, who have the necessary knowledge and are approved for working on heating and gas systems.

Before the boiler is fired, ensure that the boiler and the system are well de-aerated and free of air. Purge the gas line between the gas meter and the boiler.

WARNING

Failure to properly commission the boiler as described in section 13 may result in unreliable burner operation, reduced component life, and unsafe boiler operation.

NOTICE

The boiler and its individual shut off valve must be disconnected from the gas supply piping system during any pressure testing of that system at test pressures in excess of 1/2 PSI (3.5kPa).

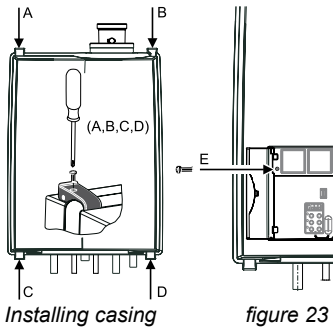

To commission the boiler the casing has to be removed.

- remove the 4 screws A,B,C and D in the quick releases of the casing (figure 23);
- remove the screw E behind the door on the front of the casing (figure 23);
- remove it towards the front.

The boiler settings, such as burner pressure and adjustment of the air quantity are unnecessary in most cases, due to the fact that the boiler operates with a zero pressure control. This means the correct gas quantity is controlled by the suction operation of the fan. The fine adjustment of the zero pressure, which is carried out at the factory is once-only, which means that adjusting of this value is unnecessary. Only in case of replacing of the gas valve, venturi and/or fan the zero pressure adjustment has to be checked and, if necessary, adjusted to the right value.

WARNING

The venturi must always be checked and adjusted when it is out of range see section 12.3 on O₂ adjustment.

DANGER

Always check the installation of all parts through which gas flows (by bubble test using leak-search spray).

Pump commissioning procedure should be followed before the boiler is fired for the first time:

1. Remove the vent pump screw
2. Use a small flat head screw driver to ensure the impeller spins freely.
3. When the impeller spins freely and water exits through the vent port the pump is ready for operation.
4. Replace the vent screw

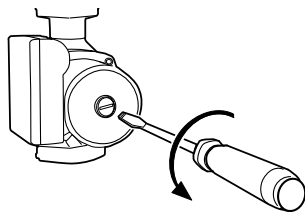

Pump commissioning
figure 23a

During the commissioning of the boiler the Rinnai Installation, Commissioning, and Service card must be filled out.

12.1 Testing for gas leaks

Prior to start-up of the boiler you must check the external tightness of the gas supply valve and confirm this in the start-up report.



WARNING

- Before leaking testing the boiler, ensure all parts of the boiler such as electronics and wiring are properly covered and protected from the leak testing agent.
- Do not spray the leak testing agent onto cables, plugs, electrical connection lines or electronic circuit boards. Do not allow it to drip onto them either.



DANGER

Leaks may be caused to pipes and screw connections during commissioning and maintenance activities.

- Carry out a proper leak test.
- Only use approved leak detection agents for leak detection.
- Disconnect the heating system from the power supply.
- Check the exterior tightness of new conduit sections up to and including the direct sealing point on the gas burner fitting. The maximum test pressure allowed on the input of the gas burner fitting is 14 inch W.C. (35mbar).

12.2 Testing the Ignition Safety shut off device

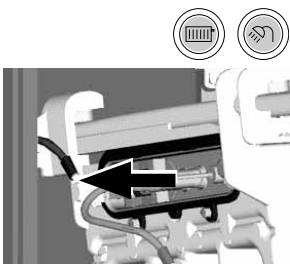

- Switch off system using the Central Heating button and the DHW button

- Disconnect the plug and socket connection of the ionization cable.



- Switch on the system using the Central Heating button and the DHW button.





- Press the MODE-button for 5 seconds.



- The display will show COdE followed by an arbitrary number;



- Select by means of the  or the  button the code C123;



- Press the Store-button to confirm the code (code blinks 1 x);



- Press the MODE-button until SERV is shown;



- Press the STEP-button once until 1 is shown; alternately 1 and OFF will be shown.



- Press the  button once; Check if the boiler does one start-up attempt and four restart attempts. After the last start-up attempt, the boiler will lock out. The gas valve is shut off. The E02 code is blinking in the display.



- Connect the plug and socket connection of the ionization cable.



- Press the reset button.

- Check if the boiler starts-up.

Do not touch the inside of the ignition cable while it is disconnected during start up of the boiler.



WARNING

12.3 Checking the O₂

i NOTICE

The O₂ percentage setting has to be checked at commissioning, maintenance and faults and adjusted if needed.

! WARNING

The O₂ percentage always must be checked and adjusted after a conversion from NG to LP or from LP to NG. This process must be done with a calibrated combustion analyzer that has been set to the correct gas type.

This can be checked by means of the following procedure:

- Remove the black cover of the gas valve by unscrewing the sealed screw.
- Put the boiler into operation and take care that it can deliver its heat;

i

Tip: If there is no demand for heat on CH, turn the hot water tap completely open and measure the O₂.



M

- Press the MODE-button for 5 seconds.

COdE

- The display will show COdE followed by an arbitrary number;

C123

- Select by means of the  or the  button the code C123;



- Press the Store-button to confirm the code (code blinks 1 x);

M

- Press the MODE-button until SERV is shown;

S 1 OFF

- Press the STEP-button once until 1 is shown; alternately 1 and OFF will be shown.

- Calibrate the O₂ meter ;

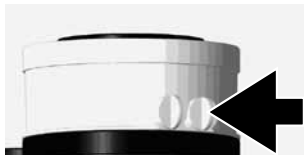

checkpoint O₂

figure 25

- Place the probe of the O₂ meter into the check point (see fig. 25);

- Press the  button until the maximum value (in kW) is achieved; The boiler will burn on full load (value on display in kW) value in BTU/hr = x3415

i NOTICE

When adjusting from max. to min. load it is advisable to stop at medium load to allow the boiler to stabilize. Adjusting quickly from max. to min. could force the boiler into an error state.

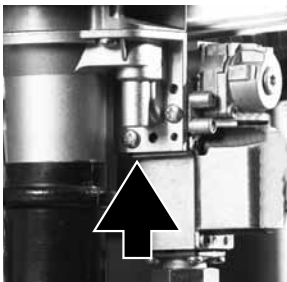

adjustment screw O₂ fig. 26

- Check the O₂ percentage:

Natural Gas: full load:	between 4.4% and 4.7%
min. load:	setting of full load +0.2% or greater
Propane: full load:	between 4.8% and 5.1%
min. load:	setting of full load +0.2% or greater

Example: Full load set on 4.6% O₂ (natural gas) then the minimum load setting should be 4.8% or greater.

i NOTICE

Choose the right O₂ value according the kind of gas (Natural Gas or Propane Gas). Wrong adjustment may result causing property damage, personal injury or death.

- Let the O₂ meter do its measuring procedure.
- Adjust, if necessary, the adjustment screw to correct the O₂ value (see fig. 26). Allow boiler to stabilize before reading the new value.

Ending the O₂ measuring procedure:

- Press the - button until **OFF** is shown (keep button pressed).
With this the procedure has ended..
- Replace the black cover on the gas valve and secure it with the screw.

12.4 Measuring the ionization current



- Switch off the system using the Central Heating button and the DHW button

- Disconnect the plug and the socket connection on the probe and connect the measuring device in series. See figure 27. Select the μ A direct current range on the measuring device. The measuring device must have a resolution of at least 1 μ A.



Ionization test figure 27



- Switch on the system using the Central Heating button and the DHW button.



- Press the MODE-button for 5 seconds.



- The display will show COdE followed by an arbitrary number;



- Select by means of the or the button the code C123;



- Press the Store-button to confirm the code (code blinks 1 x);



- Press the MODE-button until SERV is shown;



- Press the STEP-button once until 1 is shown; alternately 1 and OFF will be shown.



- Press the button until the maximum value (in kW) is achieved;
The boiler will burn on full load (value on display in kW)
value in BTU/hr = x3415

- Measure the ionization. When the boiler is in full load the ionization current must be > 4 μ A and write down this value in the log book.



- Press the button until OFF is shown (keep button pressed).



- Switch off the system using the Central Heating button and the DHW button

- Disconnect the measuring device and restore the plug and the socket connection on the probe.



- Switch on the system using the Central Heating button and the DHW button.

12.5 Installing the casing

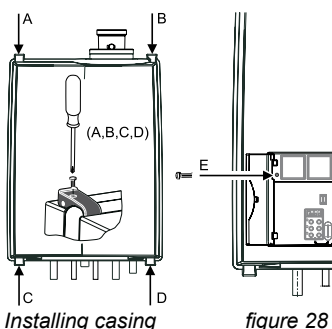

- Install the cover on the boiler and close all 4 quick releases of the casing
- Tighten the 4 screws A,B,C and D in the quick releases (figure 28);
- Tighten the screw E behind the door on the front of the casing (figure 28);

13 Maintenance

NOTICE

Maintenance or changes to the boiler may only be carried out by a qualified technician.

13.1 Periodic examination of venting systems and boiler

The inspection of the boiler and venting system should be done every 2 years or 2000 hours and full maintenance every 4 years or 4000 hours of operation, whichever occurs first. When doing this the circumstances of the boiler's location must be taken into account. From this one can determine whether to deviate from this advice.

NOTICE

Please contact Rinnai for further guidance on the frequency and service requirements. Contact details can be found on the back page of this manual.

13.2 Inspection

Preparing the boiler for inspection

To carry out the maintenance activities please follow the next procedure:

- Switch off the power supply;
- Shut off the gas;
- Valve off the boiler from the system using the boiler isolation valves in the plumbing kit.
- Remove the 4 screws A,B,C and D in the quick releases of the casing (figure 29);
- Remove the screw E behind the door on the front of the casing (figure 30);
- Remove it towards the front.
- Clean the casing with a cloth with a simple (non-abrasive) cleaning agent;

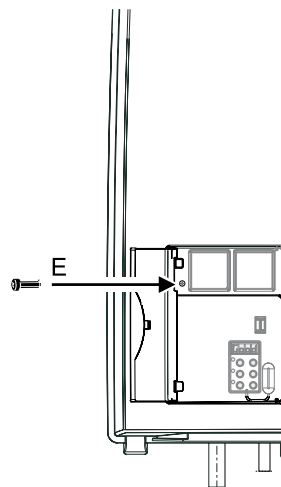
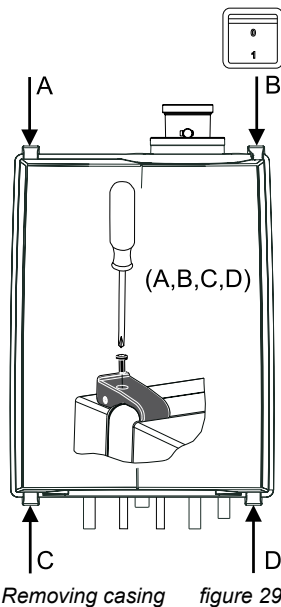

13.2.1 Visual inspection for general signs of corrosion

- Check all gas and water pipes for signs of corrosion.
- Replace any pipes that are corroded.

13.2.2 Measuring the ionization current

See subsection 12.5 "Measuring the ionization current".

13.2.3 Measuring the inlet gas pressure

See subsection 6.4.1 and .2 "Gas connection with natural gas" and "Gas connection with propane".

13.2.4 Testing for gas leaks

See subsection 12.1 "Testing for gas leaks".

13.2.5 Carrying out a pressure test of the heating system

See chapter 9.2 "Filling the heating system".

13.2.6 Checking venting systems

Check the following points:

- Is the prescribed combustion air/flue system used?
- Have the instructions for configuring the flue system as specified in the relevant Installation instruction for the flue gas system been observed?
- Check air intake and/or air filter and flue gas for obstruction, pollution or damage.



NOTICE

When an air filter is used the air filter must be replaced yearly on boilers operating in normal circumstances.

The conditions (eg. supply air quality) in which the boiler is installed should be taken into account. This will show whether the frequency of replacement should be reduced or increased. If in doubt, contact RINNAI.

13.3 Maintenance activities

The fan unit and burner cassette (figure 31 to 33) (every 4 year maintenance)

- Remove the electrical connection plug from the gas valve (1) and fan motor (2);
- Loosen the nut (3) of the gas pipe under the gas valve;
- **Replace the gasket with a new one;**
- Loosen the front cross head screw (4) of the black plastic silencer;
- After this turn the two clamping rods (9 and 10) ¼ turn and remove them by pulling them forward. **Note the correct turning direction (red indicator. fig. 33);**
- Slightly lift the fan unit and remove it towards the front of the heat exchanger;
- Remove the burner cassette out of the fan unit;
- Check the burner cassette for wear, pollution and possible cracks. Clean the burner cassette with a soft brush and vacuum cleaner.

NOTICE

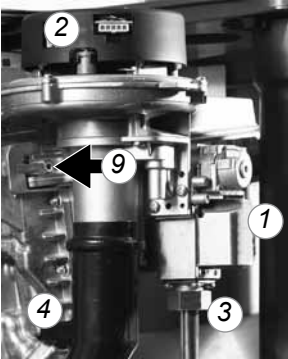

fan unit and gas valve
figure 31

NOTICE

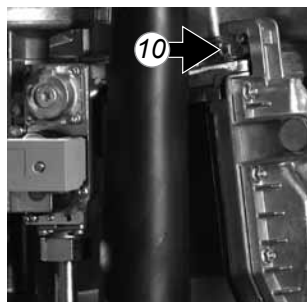

figure 32

If burners are cracked replace the complete burner cassette;

- **Replace the gaskets between burner and fan unit and the gasket between fan unit and heat exchanger;**
- Check the venturi and the gas-air distribution plate for pollution and clean this part, if necessary with a soft brush and vacuum cleaner. If the air box contains a lot of dirt it is plausible that the fan itself is dirty as well. To clean this, the fan has to be removed from the hood and the venturi. Clean the fan with a soft brush and a vacuum cleaner. Replace the gasket and ensure that all gaskets of the fan parts are mounted correctly.

Heat exchanger (every 4 year maintenance)

- Check the heat exchanger for contamination. Clean this if necessary with a soft brush and a vacuum cleaner. Prevent dirt falling down into the heat exchanger.

NOTICE

Flushing the heat exchanger from the top down is not permitted

Refitting of the components is done in reverse order.

Make sure that during refitting the clamping rods they are put in the right position. They should be turned vertical.

If the boiler should activated with clamping rods in the wrong position it will cause serious property damage, personal injury or loss of life.

Ignition electrode (every 4 year maintenance)

This can be checked by measuring the ionization current. The minimum ionization current has to be higher than 4µA on full load.

If the inspection glass is damaged the complete electrode must be replaced.

Replace the ignition assembly after every 4 year, whichever occurs first.

Replacement goes as follows:

- Remove the electrical connections of the electrode;
- Press the clips on both sides of the electrode to both sides and remove the complete electrode;
- Remove and replace the gasket;

Refitting of the components is done in reverse order.

DANGER



Clamping rods
figure 33

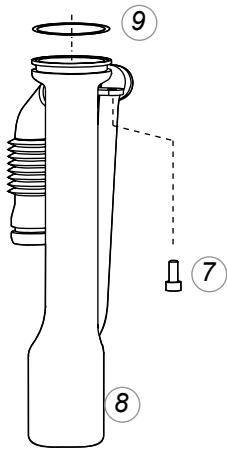

Condensate trap and condensate tray (figure 34-36) (2 and 4 year maintenance)

Step 1: Condensate trap

- First remove the screw (7);
- Pull the condensation cup (8) downwards, out of the condensate tray (14)
Check this for impurities. If there is not a lot of impurities it is not necessary to clean the condensate tray (Go to Step 3). If there is a lot of impurities in the cup it is necessary to remove and clean the condensate tray according Step 2;
- Check the O-ring (9) of the cup and replace if necessary;
- Clean the parts by flushing it with clean water;
- Grease the O-ring again with acid free O-ring grease to make fitting easier;
- If there is a leak at the condensate trap (8) replace complete condensate trap by # 809000100;

Step 2: Condensate tray

- Remove the plug from the flue gas sensor if present;
- Turn the two short clamping rods (11 and 12) ¼ turn and remove them by pulling them forward; Note the right turning direction (red indicator);
- Lift the exhaust pipe (13) out of the condensate tray (14);
- Press the condensate tray (14) carefully downwards and remove it by pulling it forward;
- Replace the gasket between condensate tray and heat exchanger by a new one;
- Clean the condensate tray with water and a hard brush;
- Check the condensate tray on leaks.

Siphon figure 34

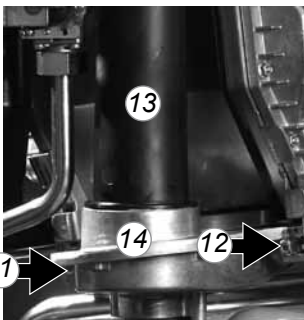

Condensate tray figure 35

Step 3: Refitting is done in reverse order.
Note that all gaskets seals completely.

Make sure that during refitting the clamping rods they are put in the right position. They should be turned vertical.

If the boiler should activated with clamping rods in the wrong position it will cause serious property damage, personal injury or loss of life.

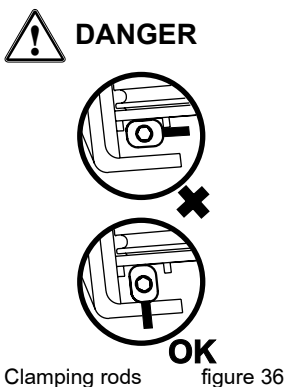

Clamping rods figure 36



Put the boiler into operation and check the O₂ (see chapter 12.4).

If replacement by new gaskets and burner mentioned in this chapter is not done within the service interval subscribed by Rinnai the boiler can be damaged and will cause serious property damage, personal injury or loss of life.

Use only original spare parts supplied by Rinnai. If other parts will be used the boiler can be damaged and will cause serious property damage, personal injury or loss of life. Use of non-Rinnai parts will result in the void of warranty.

Cleaning the Brazed Plate Heat exchanger (Every 2 year maintenance or as needed based on water quality)

The brazed plate heat exchanger should be cleaned at the service interval every 2 years. Failure to flush the brazed plate heat exchanger will cause damage to it. Follow the procedure below for cleaning the brazed plate heat exchanger.

1. Turn off the DHW function on the boiler.
2. Close the shutoff valves on both the hot water and cold water lines (V3 and V4).
3. Connect pump outlet hose (H1) to the hot water line at service valve (V1).
4. Connect drain hose (H3) to service valve (V2).
5. Pour approximately 4 gallons of virgin, food grade, white vinegar or citric acid into pail.

6. Place the drain hose (H3) and the hose (H2) to the pump (CP) inlet into the cleaning solution.
7. Open both service valves (V1 and V2) on the hot water and cold water lines.
8. Operate the pump (CP) and allow the cleaning solution to circulate through the brazed plate heat exchanger for at least 45 minutes.
9. Turn off the pump (CP).
10. Rinse the cleaning solution from the brazed plate heat exchanger as follows:
 - a. Remove the free end of the drain hose (H3) from the pail
 - b. Close service valve, (V2), and open shutoff valve, (V4). Do not open shutoff valve, (V3).
 - c. Disconnect both H1 and H3 from the service valves
 - d. Connect H3 to V1 and place the end of the hose in a drain
 - e. Allow water to flow through the brazed plate heat exchanger for 5 minutes
 - f. Close service valve, (V1), and open shutoff valve, (V3).
11. Disconnect all hoses.

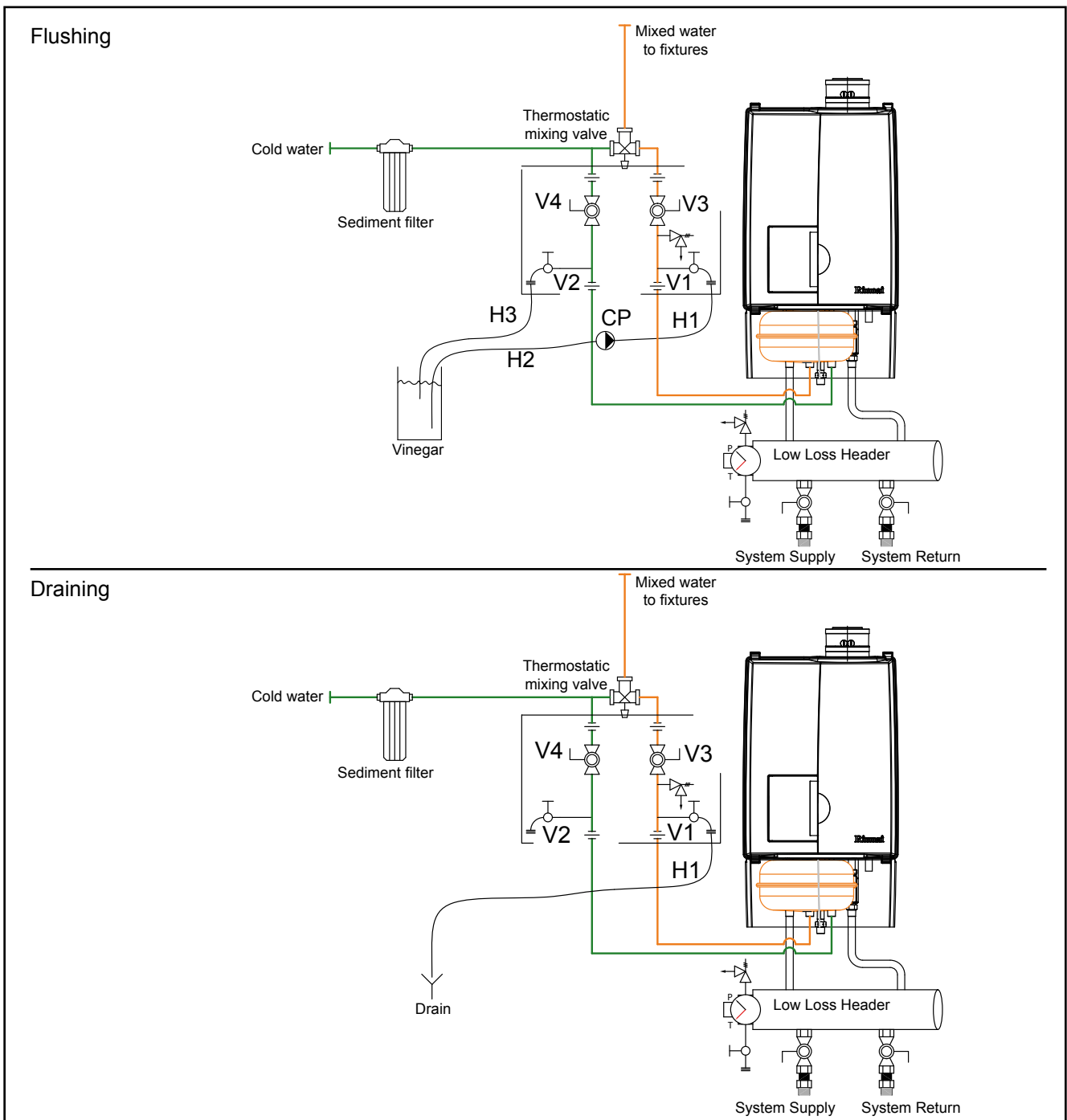

Flushing and draining

figure 37

Visual inspection of the flame (2 and 4 year maintenance)

The burner must flame evenly over the entire surface when operating correctly. The flame must burn with a clear, blue, stable flame.

Check the flame through the inspection glass in the ignition probe (fig. 38).

The flame pattern should be as shown in the figures below.

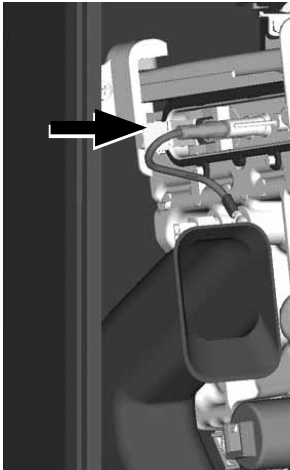

Inspection glass figure 38

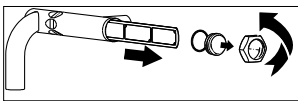
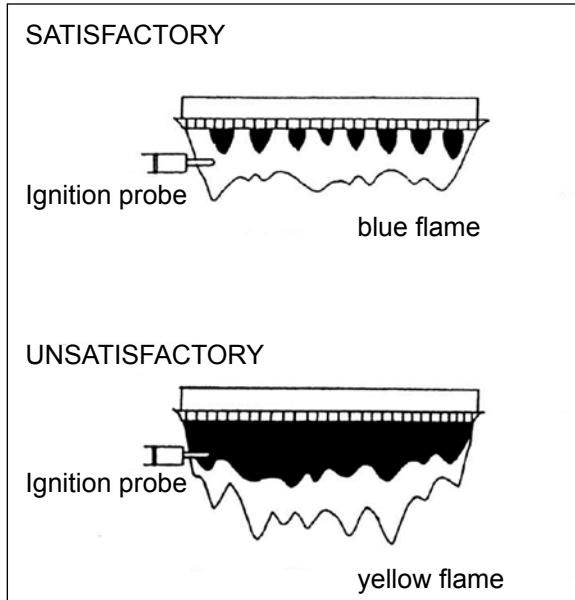

Water filter figure 44a



Further checks:

- Inspect the pressure relief valve
- Clean the water filter in the return pipe
- Check the pH of the water or glycol/water mixture.

The combustion must be checked and adjusted if required at both the 2 year/2000 hour and 4 year/4000 hour service intervals with a properly working combustion analyzer.

Verify proper operation after servicing. Always reset the service interval counter after full maintenance interval (every 4 years or 4000 hours of operation).

13.3.1 Reset service interval counter

At 4000 hours of use, "SERVICE" will scroll across the display. "Good" will display as well alternatively.

To reset the 4000 hour service notification:

CODE 123

M SERV

SERV

- Enter the 1st Tier Settings: 123 Code
- Briefly press "Mode" again until the Service Chapter is displayed (SERV)
- Hold the "Store" button until SERV flashes once—the service notification will no longer show during normal operation and the countdown to service will reset to 4000.

13.4 Warranty

For warranty conditions refer to the warranty card supplied with the boiler.

14 Parts of the boiler

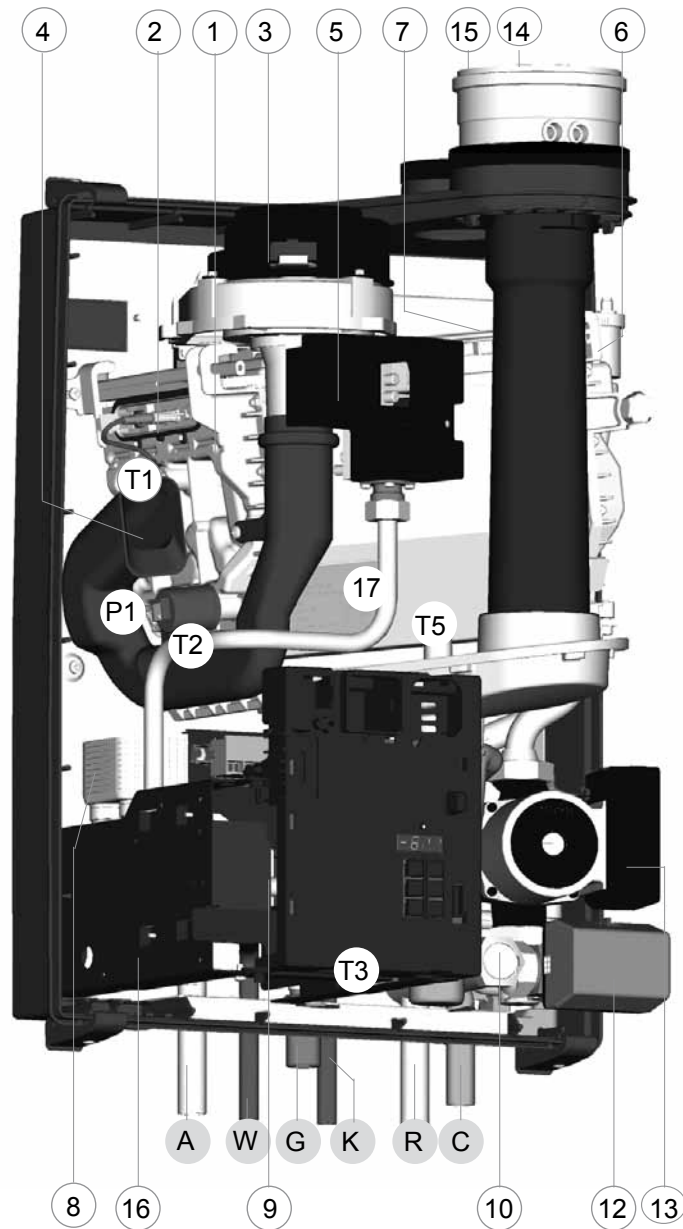

Rinnai E-Series

figure 32

- | | | |
|----------------------------|-----------------------------------|-------------------------------|
| 1 heat exchanger | 9 operating panel | 17 ASME / NB / CRN data plate |
| 2 ignition unit | 10 Control Tower (CMS) | |
| 3 fan unit | 11 water filter return CH | |
| 4 air inlet damper | 12 three-way valve | |
| 5 gas valve | 13 circulation pump | |
| 6 automatic de-aerator | 14 exhaust | |
| 7 ceramic burner cassette | 15 combustion air supply | |
| 8 plate heat exchanger DHW | 16 CSA Data Plate (serial number) | |

T1 supply sensor
 T2 return sensor
 T3 sensor DHW and flow switch

P1 water pressure sensor

G gas pipe
 A supply central heating
 R return central heating
 C condensate pipe
 K cold water pipe
 W hot water pipe

15.1 Error indication (short reference)

A detected error is indicated on the display by means of blocking or error messages. A distinction should be made between these two messages due to the fact that blocking can be of a temporary nature, however, error messages are fixed lockings. The control will try its utmost to prevent locking and will temporarily switch off the unit by blocking it. Hereunder is a list of some messages.

Blocks **bL** with a number in the last 2 positions.

- bL01** Block 01:
External safety contact cut off
- bL60** Block 60:
Incorrect parameter setting of the minimum or maximum power.
- bL67** Block 67:
A ΔT has been detected between flow and return sensor whereas the burner is not in operation.
After the ΔT has disappeared the block will clear.
- bL85** Block 85:
The control has not detected a water flow. The venting cycle is started.
If during this cycle water flow is detected, the venting cycle is ended and the burner is released.

Error **E** with a number in the last two positions.

- E 00** Error 00: Poor flame-forming
- E 02** Error 02: no flame-forming
- E 04** Error 04: adjustment or error for voltage interruption
- E 05** Error 05: adjustment
- E 12** Error 12: high limit stat
- E 18** Error 18: maximum flow temperature exceeded
- E 19** Error 19: maximum return temperature exceeded
- E 28** Error 28: number of revolutions not reported back from fan
- E 69** Error 69: no or incorrect display
- FUSE** FUSE: 24V fuse defective



The following pages describes more detailed follow up instructions for solving blockings, errors and practical circumstances. These instructions are only for by Rinnai trained installers and technicians.

15.2 Blocks

An error, which has been detected, is indicated on the display by a block message. Blocks can be temporary in nature. The controller will do everything possible to prevent a system lock and temporarily switching off the boiler as a result of a block. Please see below for a summary of blocks.

Blocks **bL** with a figure on the last 2 characters.

Code	Description	Solution
bL01	External safety contact open	Rectify error as a result of which by determining contact is open. Or repair interconnection between 24/25
bL11	Maximum average ΔT of supply and return sensor for central heating is repeatedly exceeded. Operation is normally possible for the hot water supply during the block. The pump continues to operate at minimum capacity during the block.	Check flow through the installation. See the installation instructions for the hydraulic connections to the boiler (3-Way-Thermostatic valve, Plumbing Kit installed?) Possible causes: (radiator) shut-off valves closed or blocked water filter Activeted room sensor (RS101) in non leading room (closed thermostatic radiator valves?) Check pump height. Check minimum and maximum Temperature difference in Parameter Step 46 + 47.
bL12	Maximum average ΔT of supply and return sensor for hot water is repeatedly exceeded. Operation is normally possible for the central heating installation during the block. The pump continues to operate at minimum capacity during the block.	Check flow through the boiler and DHW tank See the installation instructions for the hydraulic connections to the boiler Possible causes: (radiator) shut-off valves closed or blocked water filter resistance (coil) in tank to high (see pump height) Check 3-way-valve on function and pollution.
bL60	Incorrect parameter setting for the minimum or maximum power	Call Rinnai
bL67	A temperature difference has been detected between the supply and return sensor whilst the burner is not in operation. After the average ΔT has disappeared, the block will disappear.	Check the supply and return sensor for the resistance value and replace the defective sensor Check the installation for any external heat source and rectify this
bL80	flue sensor temperature too high	Check vent system
bL81	flue sensor or thermostat contact open	Call Rinnai
bL82	flue sensor or thermostat contact closed	Call Rinnai
bL84	flue gas thermostat contact open	Check vent system or check parameter 84 for default
bL85	no water flow can be detected through the controller. De-aeration cycle is started. When water flow is detected during this cycle, the de-aeration cycle is terminated and the burner is released. The controller checks the water pressure during static and dynamic situation.	- check the installation for the presence of air; If there is a secondary pump installed and it is not hydraulically separated, it could cause pressure differences. - check the use of balancing valves check if the pump is functioning and/or that the water pressure sensor is working properly; Polluted pump; Polluted water pressure sensor; Polluted water filter; Wiring of pump.
bL86	The frequency of the power supply deviates more than + or -1.5Hz	check the main power supply

15.3 Errors



Code	Description	Solution
E 00	Incorrect flame formation. boiler has not been burning but an ionization flow (flame) has still been detected	<p>Check whether the ionization cable and/or the electrode are responsible for a possible short-circuit. Remove the plugs from the ionization cable connected to the control unit and to the electrode. Now using a universal meter take a measurement between the ionization connection and the ground, now refit it part by part until a short-circuit takes place.</p> <hr/> <p>Rectify the short-circuit and if necessary replace this part.</p>
E 01	24 Volt short-circuit	<p>Check the 24 Volt connection. Remove all plugs with 24 Volt connections such as: fan, pump, any three-port valve and 24 Volt plug to the connecting block.</p> <hr/> <p>Check short circuit of disconnected components. Switch on power again to the control unit with the components disconnected. Reconnect the components, which have been checked and are working.</p> <hr/> <p>Rectify the short-circuit or replace the short-circuited component.</p>
E 02	No flame formation	<p>Check the data in Error mode. Boiler data during error.</p> <p>1 error = 02 2 operational status = 02 3 supply temp. = xx* 4 return temp. = xx* 5 kW burner = xx** 6 % pump = xx*</p> <p>* = variable value ** = x 3451 = BTU/hr</p> <hr/> <p>1 No temperature difference between supply (3) and return (4)</p> <p>Boiler has not been able to ignite any gas or has not received any gas. Boiler tries to start 6 times with an increasing starting load after the safety time</p> <p>Check whether:</p> <ul style="list-style-type: none"> - the gas valve is open; - there is power to the gas valve; - that the gas valve opens <p>The minimum gas pre-pressure during the start must be a minimum of 7"W.C. (17 mbar), check the 24 Volts in the gas during ignition block's open position</p> <hr/> <p>2 There is a temperature difference between supply (3) and return (4)</p> <p>Boiler has gone out after ignition. Due to insufficient ionization the burner has gone out after ignition</p> <p>Ionization flow, ionization cable or the O₂ setting. The minimum ionization current should be 4 µA, the O₂ should be a minimum of 4.4% for NG or 4.8% for LP</p>
E 03	Control unit error	<p>Connector not plugged into the gas valve or defect in the wiring of the gas valve.</p> <hr/> <p>Software error control unit. Replace the control unit. The display will automatically load the program into the new controller.</p>
E 04	The controller has detected a program error	<p>Reset the boiler. the boiler automatically indicates this message if during an error read-out the electrical power to the boiler is shut off. After the power has once again switched on, if the error causing the interference is no longer present, this message is given.</p> <hr/> <p>Rectify the preceding error, If Error 04 persists, and preceding errors do not occur, replace controller.</p>
E 05	Control unit error	<p>Check 120V stability. If voltage is deviating more between +10% and -15% the electrical power supply needs to stabilised.</p> <hr/> <p>The error persists after reset</p> <p>Software error control unit. Replace the control unit. Remove the E-Prom from the defective control unit and place it onto the new control unit. The controller will automatically load the program into the new control unit.</p>
E 06	Control unit error	<p>Moisture on the PCB. Check if there is water leaking on or in the boiler.</p> <hr/> <p>Stop leak and replace MCBA controller</p>

Code	Description	Solution
E 07	Control unit error	
1	Anticipation resistance wire not present	When a power stealing room stat device is placed the connection terminal needs to be provided with the special anticipation resistance wire.
2	Software error control unit.	Software error control unit. Replace the control unit. Remove the E-Prom from the defective control unit and place it onto the new control unit .The controller will automatically load the program into the new control unit.
E 12	High limit stat open	Supply temperature too high. Caused by - presence of air - possible polluted impeller of the circulation boiler pump - polluted internal filter Check de-aerator. Replace when necessary the automatic de-aerator and restart boiler for de-aerating programm (17min.) Check water flow over system. Clean when necessary the pump and or filter. Flush complete system Check adjustment of balancing valves
E 13	Control unit error	Software error control unit. Replace the control unit. Remove the E-Prom from the defective control unit and place it onto the new control unit .The controller will automatically load the program into the new control unit.
E 14	- T3 flow sensor ground connection - T3 flow sensor failure - controller failure	Check the data in Error mode. Boiler data during error: 1 Error = 14 2 Operational status = 00 3 Flow temp. = -22 4 Return temp. = xx* 5 kW burner = 00** 6 % pomp = xx* * = variable values **= x3415=BTU/hr A temperature of - 36 is displayed at position 3. Check the wiring and/or measure the resistance of the flow sensor. The resistance should be approx. 12 kOhm at 77°F. (See table in Appendix B) If necessary, replace the flow sensor
E 18	Signal maximum flow water temperature exceeded ($T_1 > 212^\circ\text{F}$).	Check actual flow temperature. suddenly increase caused by completely hydraulic shut off of the boiler (filter, pump, thermostat valve, service valve) Check flow sensor NTC1. measure the resistance value (see Appendix B) Exchange defective part if necessary. Change control unit when error persists.
E 19	Signal maximum return water temperature exceeded ($T_2 > 212^\circ\text{F}$).	Check actual return temperature. Increase of temperature caused by external heating source? Check return sensor NTC 2. Measure the resistance value (see Appendix B) Exchange defective part if necessary. Change control unit when error persists
E 24	T1 and T2 (swapped).	T2 temperature is measured to be higher than T1. Check resistance value of T1 and T2 (See Appendix B) and replace T1 or T2.
E 26	Controller failure	Replace controller

Code	Description	Solution
E 28	No signal from the fan	<p>The fan is not running. Check the wiring to the fan and the control unit and/or the 24 volt power supply to the fan</p> <hr/> <p>Wiring and voltage are OK and error is repeated. Replace the fan</p>
E 29	Negative pressure on vent system (pressure difference)	<p>Check vent system. Vent system and air intake system must be installed according installation instructions.</p> <hr/> <p>IF vent system is OK: Replace fan</p>
E 31	internal shut down of supply sensor T1	<p>Check the data in Error mode. Boiler data during error:</p> <p>1 Error = 31 2 Operational status = 00 3 Flow temp. = 230 4 Return temp. = xx* 5 kW burner = 00** 6 % pomp = xx*</p> <p>* = variable values **= x3415=BTU/hr</p> <hr/> <p>Check the wiring. check the wiring for the sensor</p> <hr/> <p>The wiring is OK but the error is repeated. Remove the plug from the flow sensor as a result of which Error 36 occurs</p> <hr/> <p>Replace the sensor.</p>
E 32	Shut down of return sensor T2	<p>Check the data in Error mode. Boiler data during error:</p> <p>1 Error = 32 2 Operational status = 00 3 Flow temp. = xx* 4 Return temp. = 230 5 kW burner = 00** 6 % pomp = xx*</p> <p>* = variable values **= x3415=BTU/hr</p> <hr/> <p>Check the wiring. check the wiring for the sensor</p> <hr/> <p>The wiring is OK but the error is repeated. Remove the plug from the flow sensor as a result of which Error 37 occurs</p> <hr/> <p>Replace the sensor.</p>
E 36	contact for supply sensor T1 open	<p>Check the data in Error mode. Boiler data during error:</p> <p>1 Error = 36 2 Operational status = 00 3 Flow temp. = -22 4 Return temp. = xx* 5 kW burner = 00** 6 % pomp = xx*</p> <p>* = variable values **= x3415=BTU/hr</p> <hr/> <p>Check the wiring. check the wiring for the sensor</p> <hr/> <p>The wiring is OK but the error is repeated. Remove the plug from the flow sensor as a result of which Error 31 occurs</p> <hr/> <p>Replace the sensor.</p>

Code	Description	Solution
E 37	contact for return sensor T2 open	<p>Check the data in Error mode. Boiler data during error:</p> <p>1 Error = 37 2 Operational status = 00 3 Flow temp. = xx* 4 Return temp. = -22 5 kW burner = 00** 6 % pump = xx*</p> <p>* = variable values **= x3415=BTU/hr</p> <hr/> <p>Check the wiring. check the wiring for the sensor</p> <hr/> <p>The wiring is OK but the error is repeated. Remove the plug from the flow sensor as a result of which Error 32 occurs</p> <hr/> <p>Replace the sensor.</p>
E 41	Control unit error	Software error control unit. Replace the control unit. Remove the E-Prom from the defective control unit and place it onto the new control unit .The controller will automatically load the program into the new control unit.
E 42	Control unit error	Software error control unit. Replace the control unit. Remove the E-Prom from the defective control unit and place it onto the new control unit .The controller will automatically load the program into the new control unit.
E 44	Electrical leakage to ground.	Moisture on controller PCB. Check if there is water leaking on or in the boiler. <hr/> Stop water leak and replace controller.
E 69	No software present	Remove the E-Prom from the defective control unit and place it onto the new control unit .The controller will automatically load the program into the new control unit.
E 80	Flue gas temperature to high (adjustment parameter 84 - default 212°F)	Replace flue sensor or adjust parameter 84 to default
FUSE	Fuse on controller PCB defective or Cable transformer not connected	Replace fuse. A 4A and 5A spare fuse can be found on the back side of the Control Tower.

15.4 Other Errors

Complaint	Description	Solution
Central heating but no domestic hot water	1.  -Key of the DHW program is not switched on	Switch on DHW program on the Control Tower
	2. Flow switch is not working properly.	Check flow and/or check for impurities. Check on functioning. Replace if necessary.
	3. T3 DHW sensor in plate heat exchanger defective	Replace DHW sensor
	4. When using RS100	- Check timer times for DHW program, if necessary reset - RS100 does not respond to DHW program - See RS100 installation instructions
	5. Three-port valve is not circulating to DHW	- Check wiring. - If necessary replace the three-port valve motor.
Hot water but no central heating	1.  -Key of the central heating program is not switched on.	Switch on central heating program
	2. Room thermostat (on/off) is not giving any signal to the boiler.	Check room thermostat
	3. RS100 with outdoor sensor (Room sensor-On)	- Outdoor temperature is higher than 70°F, depending upon the Eco-temperature set (70°F is the default). Check Info chapter Step 7 or temperature is higher than the Eco temperature set (see RS100 installation instructions). - Check timer program and set room temperature.
	4. Three-port valve is not circulating to central heating position.	Check wiring, replace the three-port valve motor.
Central heating installation gets hot without being requested	1.  -Key pump program is on.	Switch off.
	2. Dirt in three-port valve or three-port valve cartridge is binding.	Clean or replace.
Insufficient quantity of hot water	1. Hot and cold water connection to the boiler mixed up.	Check left = hot, right = cold
	2. Incorrect flow reducing valve.	- Check for the type and for contamination, if necessary replace (Combi) and/or clean. - Check the comfort synchronising valve for the correct setting in accordance with the installation instructions.
	3. In the absence of positive results	Lime scale in plate heat exchanger. If necessary descale or replace
Temperature drop of the DHW (Combi)	1. Hot and cold water connection to the boiler mixed up	Check left = hot, right = cold
	2. Flow reducing valve.	Check flow reducing valve for the correct type in accordance with the installation instructions
	3. DHW power for the boiler is set too low.	- Check PARA chapter Step No. 43 - Check the functioning and wiring of the DHW sensor T3.

Complaint	Description	Solution
radiators do not get hot enough or warming them up takes too long	1. Check setting of room thermostat or RS100	See installation and user manual RS100
	2. Supply water temperature too low.	Check setting PARA chapter Step No. 1 and increase if necessary
	3. Incorrect choice of installation	PARA chapter Step No. 2 if necessary change.
	4. Installation resistance too high (given an average T > 36°F the boiler decreases the load).	- See installation instructions. - Check / clean water filter check dimensions of pipes.

Parts casing E-Series

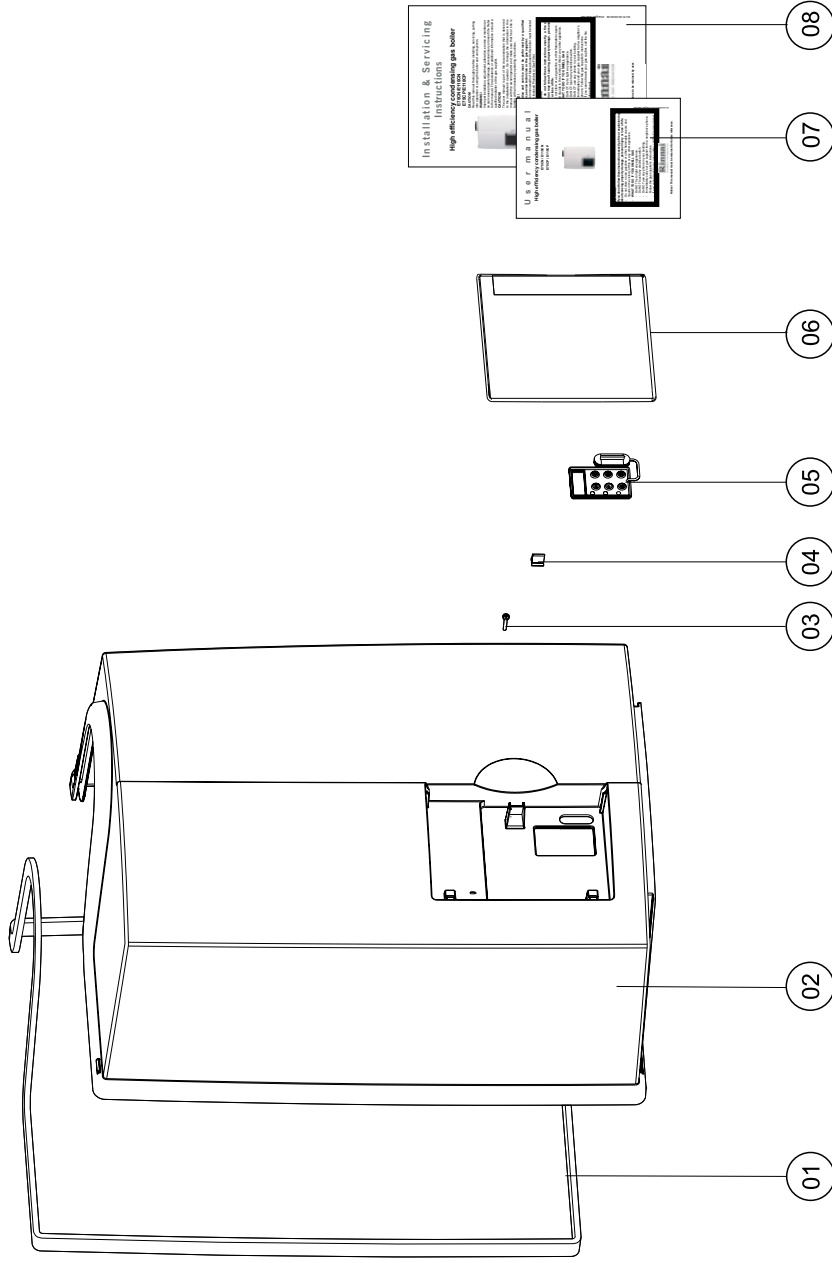

Item	Description	Part No.	E75C		E110C	
			N	P	N	P
			OSS1	OSS2		
1	GASKET CASING E	809000073	X	X	X	X
2	CASING SET	809000074	X	X	X	X
	BOILER COVER BOLT M5X20 (SET OF 5 BOLTS)	809000127	X	X	X	X
4	SPRING DOOR CASING	809000075	X	X	X	X
5	GASKET CONTROLS	809000076	X	X	X	X
6	DOOR CASING E	809000077	X	X	X	X
7	USER MANUAL E-SERIES	800000012	X	X	X	X
8	INSTALLATION MANUAL E-SERIES	800000013	X	X	X	X

Parts heat exchanger E-Series

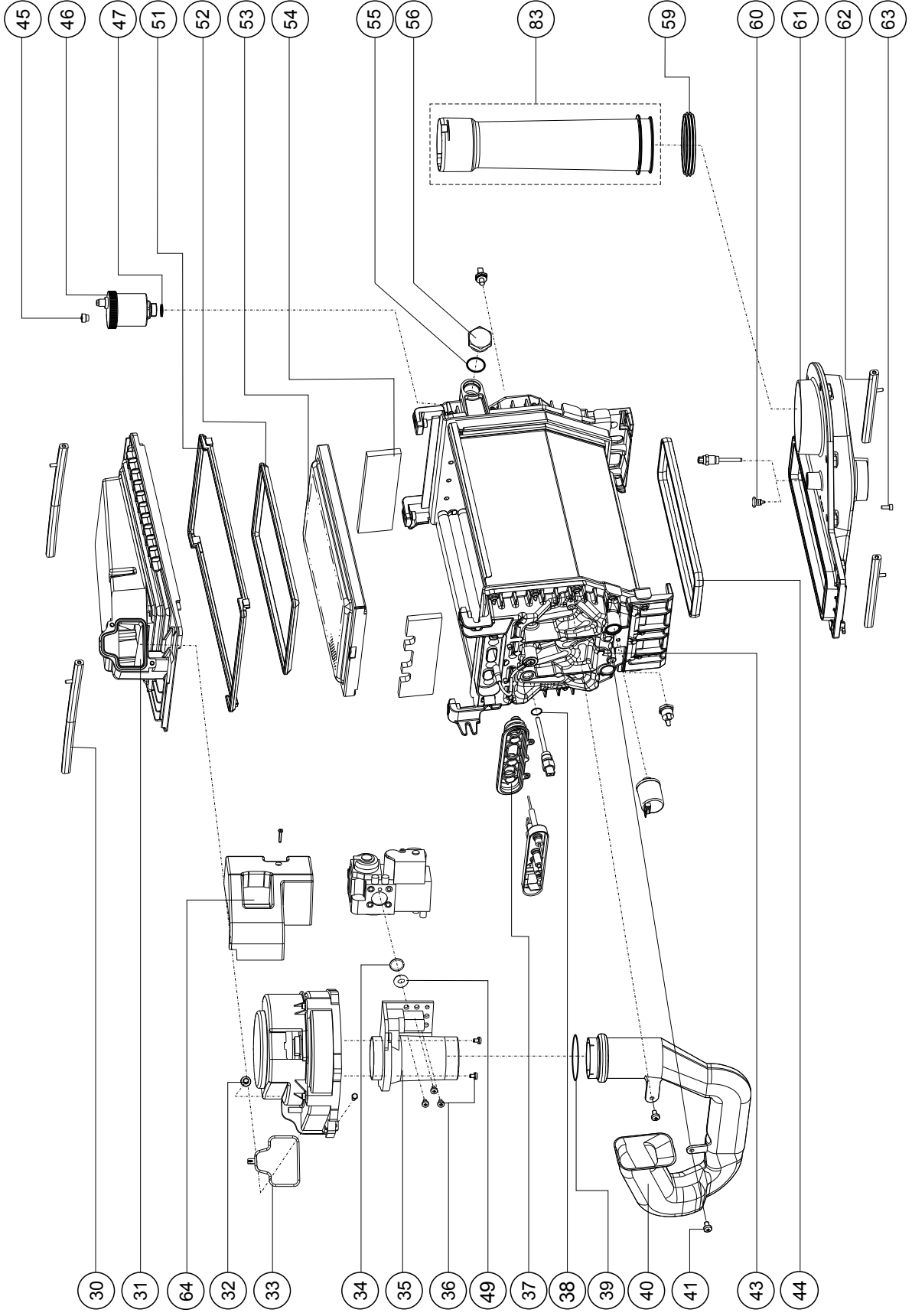

Item	Description	Part No.	E75C		E110C	
			N	P	N	P
			OSS1		OSS2	
30	CLAMP BAR TOP PART HEX. LONG	809000014	X	X	X	X
31	TOP PART HEAT EXCH. SET OSS1	807000010	X	X		
	TOP PART HEAT EXCH. SET OSS2	807000011			X	X
32	BOLT M 5X16 (5 PER PACKAGE)	809000015	X	X	X	X
33	GASKET FAN/TOP PART HEX.	809000016	X	X	X	X
34	GASKET GAS VALVE - VENTURI	809000017	X	X	X	X
	GASKET VENTURI - FAN	809000018	X	X	X	X
35	VENTURI OSS1	807000013	X	X		
	VENTURI OSS2	807000014			X	X
36	BOLT M5X12GR FASE ZSDIN7985 (5 PER PACKAGE)	809000019	X	X	X	X
38	O-RING 65.00X2.00 FLOW SENSOR (5 PER PACKAGE)	809000080	X	X	X	X
37	GASKET IONISATION/IGNITION OSS	809000020	X	X	X	X
39	GASKET SILENCER-VENTURI	809000021	X	X	X	X
40	DAMPER OSS1	807000016	X	X		
	DAMPER OSS2	807000017			X	X
41	SCREW TAPITTE M5X8 OK-PD (3 PER PACKAGE)	809000022	X	X	X	X
43	HEAT EXCHANGER OSS1 ASME	807000019	X	X		
	HEAT EXCHANGER OSS2 ASME	807000020			X	X
	BOILER TOOL KIT	809000024	X	X	X	X
44	GASKET CONDENSATE TRAY OSS1	809000025	X	X		
	GASKET CONDENSATE TRAY OSS2	809000026			X	X

Item	Description	Part No.	E75C		E110C	
			N	P	N	P
			OSS1		OSS2	
45	CAP DE-AERATOR SHR (3 PER PACKAGE)	807000023	X	X	X	X
46	DE-AERATOR CHROME	807000024	X	X	X	X
47	O-RING ø13.94X2.62 DE-AER. (2 PER PACKAGE)	809000028	X	X	X	X
48	BOLT M 3X30 VERZ DIN944 B. (3 PER PACKAGE)	809000029	X	X	X	X
51	GASKET H.E./TOP PART OSS1	809000030	X	X		
	GASKET H.E./TOP PART OSS2	809000031			X	X
52	GASKET BURNER/TOP PART OSS1	809000033	X	X		
	GASKET BURNER/TOP PART OSS2	809000034			X	X
53	BURNER CASSETTE SET OSS1	806000010	X	X		
	BURNER CASSETTE SET OSS2	806000011			X	X
54	SET INSULATION PIPE PLATE L+R	809000036	X	X	X	X
55	O-RING ø17.12X2.62 PLUG HEAT EXCH. (2 PER PACKAGE)	809000103	X	X	X	X
56	METAL PLUG HEAT EXCH 1/2"	809000115	X	X	X	X
59	LIP-RING ø63 AMGAS	809000038	X	X		
	LIP-RING ø80 AMGAS	809000039			X	X
60	PLUG FLUE GAS SENSOR	809000040	X	X	X	X
61	CONDENSATE TRAY OSS1	809000041	X	X		
	CONDENSATE TRAY OSS2	809000042			X	X
62	CLAMP BAR COND. TRAY	809000044	X	X	X	X
63	BOLT M 5X12 IMBUS VERZ. (3 PER PACKAGE)	809000045	X	X	X	X
64	COVER GAS VALVE	809000046	X	X	X	X
76	BRACKET E75C, E110C, Q85S & Q130S	809000065	X	X	X	X
77	COVER AIR SUPPLY Ø80mm	807000075	X	X	X	X
78	CONCENTRIC FLUE ADAPTOR 80/125MM	808000023	X	X	X	X

Parts rear wall E-Series

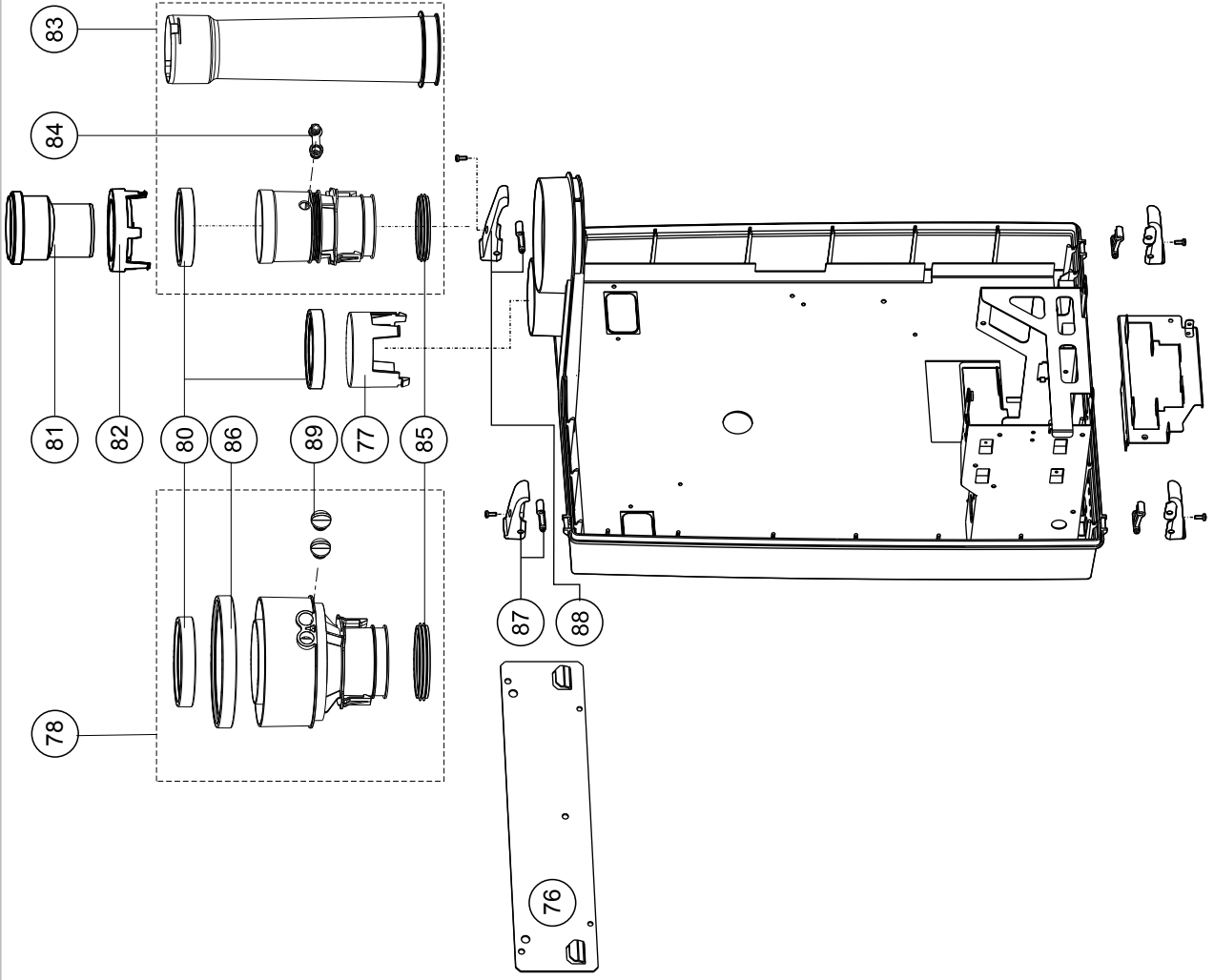

Item	Description	Part No.	E75C			E110C		
			N	P	OSS1	N	P	OSS2
80	GASKET AIR INTAKE ø80 SHR	8090000047	X	X	X	X	X	X
81	FLUE ADAPTER 80mm x 3"	808000022	X	X	X	X	X	X
82	COVER AIR SUPPLY Ø125mm	808000029	X	X	X	X	X	X
83	FLUE GAS SYSTEM PP SET OSS1	808000010	X	X				
	FLUE GAS SYSTEM PP SET OSS2	808000011				X	X	X
84	PLUG MEASURING POINT PARALLEL FLUE PIPE	808000028	X	X	X	X	X	X
85	GASKET FLUE GAS PIPE PP	809000048	X	X	X	X	X	X
86	GASKET AIR SUPPLY ø125mm	809000049	X	X	X	X	X	X
87	QUICK RELEASE SMALL E	809000078	X	X	X	X	X	X
88	QUICK RELEASE LARGE E	809000079	X	X	X	X	X	X
89	PLUG MEASURING POINT CONCENTRIC FLUE PIPE	808000030	X	X	X	X	X	X

Parts pipes E-Series

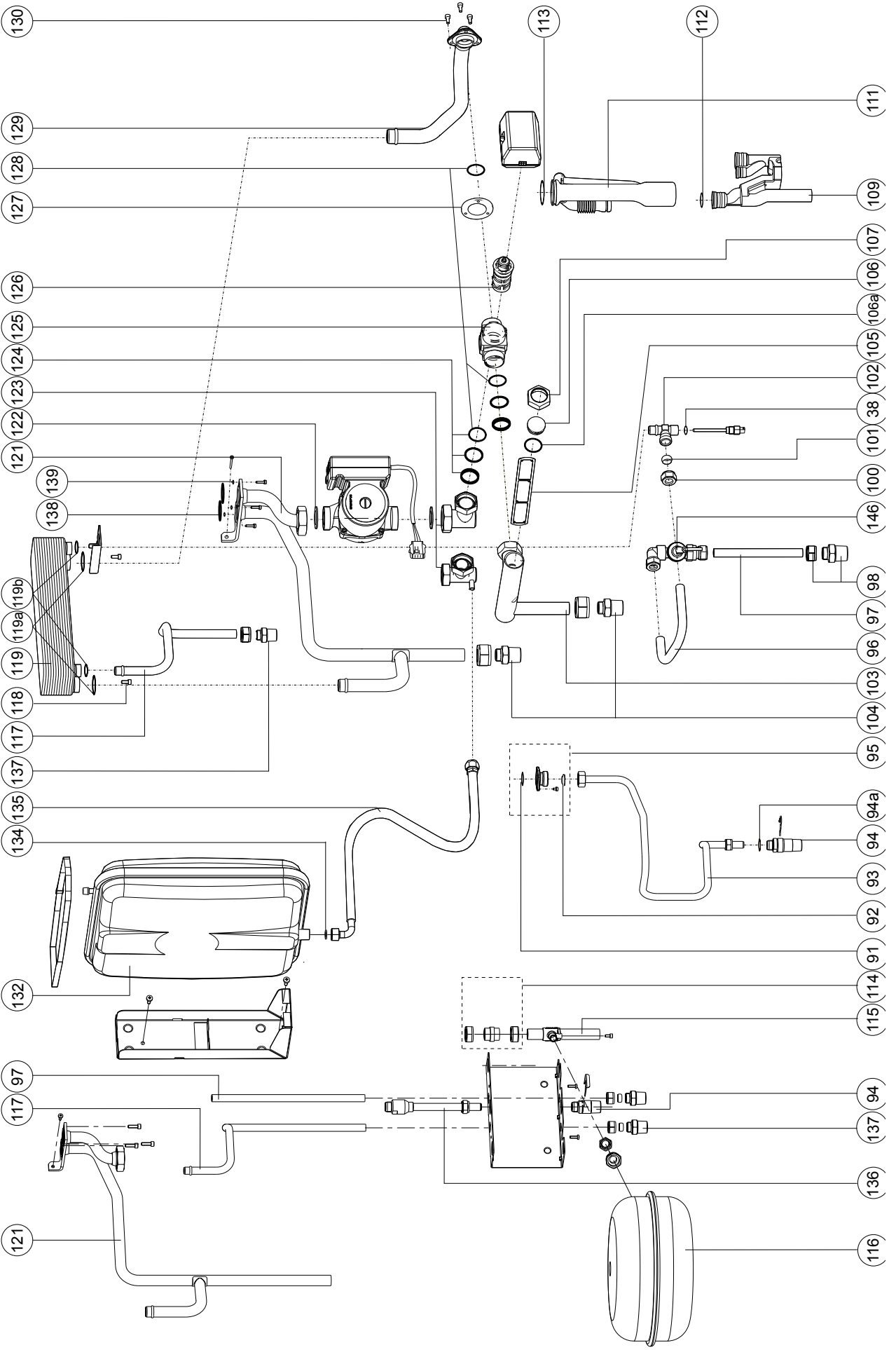

Item	Description	Part No.	E75C		E110C	
			N	P	N	P
			OSS1	OSS2		
91	O-RING ø21.89X2.62 GASLINE	809000061	X	X	X	X
92	GASKET FITTING 3/4" GASV.	809000062	X	X	X	X
93	GAS PIPE E75C	806000020	X	X		
	GAS FITTING OSS1/2 E	806000021			X	X
94	GAS FITTING OSS1/2 E	806000015	X	X	X	X
94a	O-RING ø13.94X2.62 YELLOW SILL Q	809000055	X	X	X	X
95	FITTING GAS VALVE 3/4"	806000016	X	X	X	X
96	PIPE BEND ø15 COLD WATER E	807000082	X	X	X	X
97	PIPE ø15 COLD WATER E75C	807000083	X	X		
	PIPE ø15 COLD WATER E110C	807000084			X	X
98	CONNECTION SET 15 X 3/4" NPT INCL FLOW RESTRICTOR E75 WHITE	807000072	X	X		
	CONNECTION SET 12 X 3/4" NPT INCL FLOW RESTRICTOR E110 GREEN	807000073			X	X
100	NUT 1/2" G BRASS COMPR. 15	809000070	X	X	X	X
101	FERRULE COMPR FITTING 15MM	809000069	X	X	X	X
102	T-PIECE T3 E	807000048	X	X	X	X
	O-RING ø5.00X2.00 FLOW SENSOR 5X	809000080	X	X	X	X
103	PIPE RET-3WV FILTER E	807000049	X	X	X	X
104	CONNECTION SET 22 X 3/4" M-NPT	807000069	X	X	X	X
105	FILTER RETURN PIPE	807000029	X	X	X	X
106	FILTER CAP	807000031	X	X	X	X
106a	O-RING ø25.07 X 2.62 3WV	809000058	X	X	X	X
107	NUT M35 ø30	809000059	X	X	X	X
109	CONDENSATE COLLECTOR	809000081	X	X	X	X
111	TRAP - E SERIES	809000100	X	X	X	X
112	O-RING ø40X3.53 TRAP TRAY	809000084	X	X	X	X
113	O-RING ø18.72X2.62 EPDM (3 PER PACKAGE)	809000052	X	X	X	X
114	CONNECTION SET 22MM X 22MM COMPR.	804000064			X	X
115	PIPE RET EXP VESSEL E110C	807000085			X	X

Item	Description	Part No.	E75C		E110C	
			N	P	N	P
			OSS1	OSS2		
116	EXPANSION VESSEL 12L E110C	807000052			X	X
117	PIPE ø15 HOT WATER E75C	807000053	X	X		
	PIPE ø15 HOT WATER E110C	807000086			X	X
118	BOLT M 5X12 IMBUS VERZ. (3 PER PACKAGE)	809000045	X	X	X	X
119	PLATE EXCHANGER 24KW PFESH R	807000054	X	X		
	PLATE EXCHANGER 38KW PFESH R	807000055			X	X
119a	O-RING ø21.89X2.62 EPDM CH (2 PER PACKAGE)	809000088	X	X	X	X
119b	O-RING ø13.94X2.62 DHW (2 PER PACKAGE)	809000028	X	X	X	X
121	PIPE FLOW/PL EXCH-CH E75C	807000058	X	X		
	PIPE FLOW/PL EXCH-CH E110C	807000087			X	X
	BOLT M6X20 SS IMB.BP.4.2 (3 PER PACKAGE)	809000089	3X	3X	3X	3X
122	GASKET PUMP (2 PER PACKAGE)	809000056	X	X	X	X
123	PIPE 3WV-PUMP E75C	807000060	X	X		
	PIPE 3WV-PUMP E110C	807000061			X	X
124	NUT M35 ø30	809000059	3X	3X	3X	3X
	O-RING ø26.70 X 1.78 (3 PER PACKAGE)	809000091	3X	3X	3X	3X
	FITTING SET 3 WAY VALVE	807000062	X	X	X	X
125	THREE WAY V. HOUSING VC O-RING	809000057	X	X	X	X
126	CARTRIDGE 3WV	807000030	X	X	X	X
127	FLANGE 3WV	807000063	X	X	X	X
128	O-RING ø26.70 X 1.78 (3 PER PACKAGE)	809000091	X	X	X	X
129	PIPE PL. EXCH-3WV E	807000064	X	X	X	X
130	BOLT M 5X12 IMBUS VERZ. (3 PER PACKAGE)	809000045	X	X	X	X
132	EXPANSION VESSEL 8L E75C	807000065	X	X		
134	GASKET 15X11X2 (5 PER PACKAGE)	809000092	X	X		
135	FLEXIBLE HOSE 3/8" BIX10MM CLAMP	807000066	X	X		
136	GAS PIPE EXTENDED E110C	806000024			X	X
137	CONNECTION SET 15 X 3/4" M-NPT	807000068	X	X	X	X
138	O-RING 4.8X1.8 LOCK HE Q. (3 PER PACKAGE)	809000090	3X	3X	3X	3X
139	O-RING 4.8X1.8 LOCK HE Q. (3 PER PACKAGE)	809000090	X	X	X	X

Parts electrical components E-Series

- 162 T1 supply sensor
- 160 T2 return sensor
- 167 T3 DHW sensor
- 166 T5 flue gas sensor
- 168 HLS high limit switch

- 161 P1 water pressure sensor

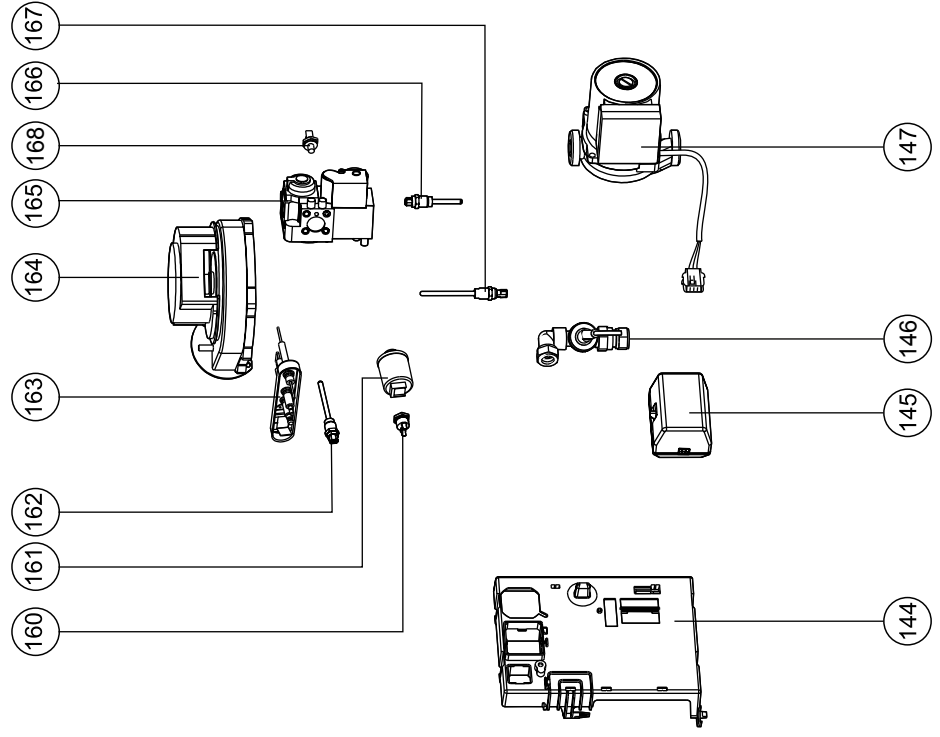
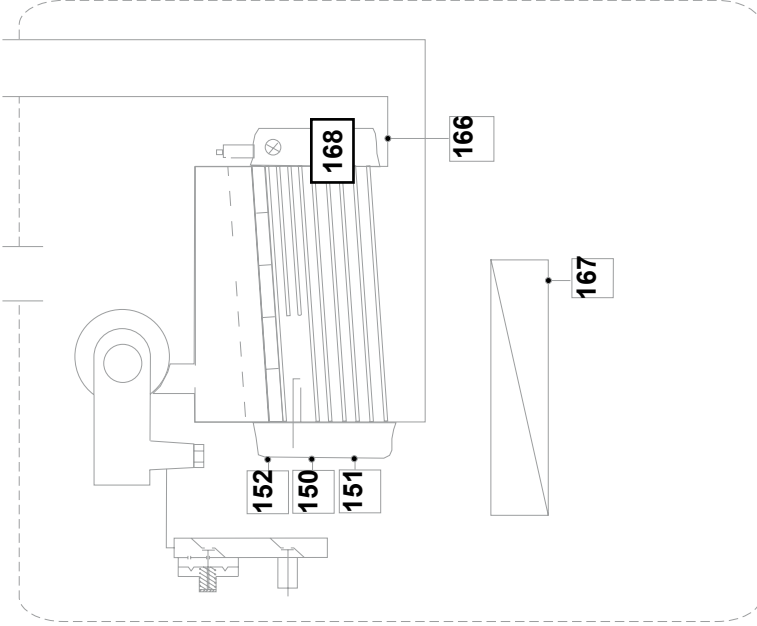

Item	Description	Part No.	E75C		E110C	
			N	P	N	P
			OSS1	OSS2		
140	HARNESSE	805000041	X	X	X	X
	STICKER CONNECTION TERMINAL	805000046	X	X	X	X
	CONNECTOR 2-POLE PURPLE	805000015	X	X	X	X
	CONNECTOR 3-POLE GRAY	805000018	X	X	X	X
	CONNECTOR 4-POLE BROWN	805000021	X	X	X	X
	CONNECTOR 2-POLE BLACK	805000016	X	X	X	X
	CONNECTOR 6-POLE BLUE	805000022	X	X	X	X
141	TRAF0 120V/24V	805000010	X	X	X	X
	SCREW 3.5X9.5 VERZ.D7983 (5 PER PACKAGE)	805000011	X	X	X	X
142	CASING CONTR.UNIT BACK E	809000093	X	X	X	X
143	CONTROL UNIT MCBA.5417 E RAC	805000025	X	X	X	X
	FUSE 5AF (3 PER PACKAGE)	805000026	X	X	X	X
	FUSE 4 AT (250V) (3 PER PACKAGE)	805000027	X	X	X	X
144	CASING CONTR.UNIT FRONT E	809000094	X	X	X	X
145	3WAY VALVE ACTUATOR VC2010	805000030	X	X	X	X
	HARNESSE DHW E	805000042	X	X	X	X
146	FLOW SWITCH 2.5L E	805000043	X	X	X	X
147	PUMP UPS20-48 120V	807000038	X	X		
	PUMP UPS20-58 120V	807000039			X	X
160	NTC T2/T3	805000032	X	X	X	X
161	WATERPRESSURE SENSOR	805000034	X	X	X	X
	WATERPRESSURE SENSOR CABLE	805000050	X	X	X	X
162	NTC T1/T3	805000035	X	X	X	X
163	IGNITION ELECTRODE+GASKET OSS	805000036	X	X	X	X
	IGNITION CABLE SHR	805000037	X	X	X	X
	IONISATION WIRE SHR	805000039	X	X	X	X
164	FAN NRG 118 OSS1/2	808000020	X	X	X	X
	HARNESSE FAN 120V	805000038	X	X	X	X
165	GAS VALVE	806000019	X	X	X	X
167	NTC T1/T3	805000035	X	X	X	X
168	HIGH LIMIT SWITCH	805000033	X	X	X	X
170	OUTDOOR RESET SENSOR ARV12	805000047	X	X	X	X

Parts plumbing kit E-Series

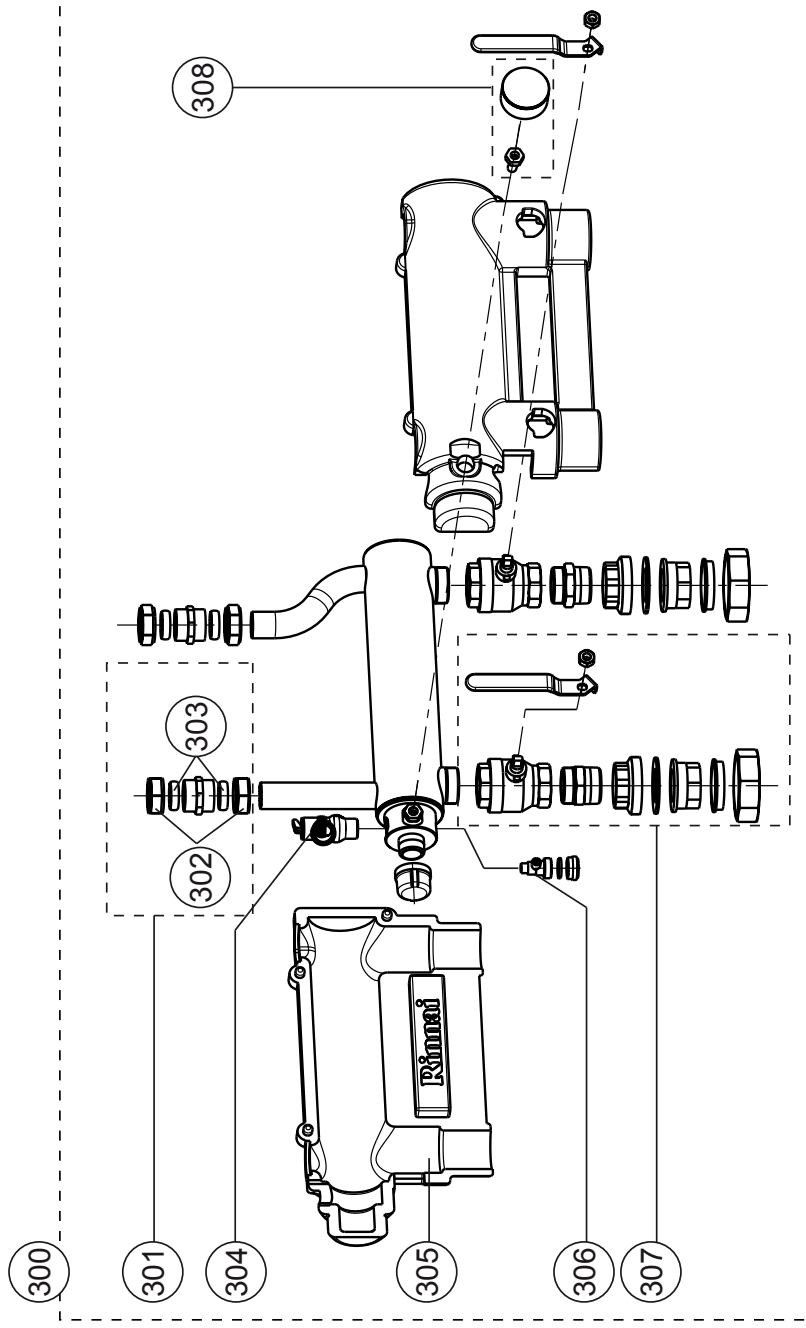

Item	Description	Part No.	E75C		E110C	
			N	P	N	P
				OSS1		OSS2
300	PLUMBING KIT #1 FOR E75C/E110C	804000061	X	X	X	X
301	CONNECTION SET 22MM X 22MM COMPR.	804000064	X	X	X	X
302	NUT COMPR FITTING 22MM	804000056	X	X	X	X
303	FERRULE COMPR FITTING 22MM	804000052	X	X	X	X
304	SAFETY VALVE 3/4" NPT	807000077	X	X	X	X
305	INSULATION PACK PL. KIT 1/2	809000101	X	X	X	X
306	BOILER DRAIN VALVE 1/4" NPT X 3/4" GH	807000078	X	X	X	X
307	SERVICE BALL VALVE + D-ELECTRIC 1 1/4"	807000079	X	X	X	X
308	T&P GAUGE 1/4"NPT + LOCK 1/2"	807000081	X	X	X	X

Parts conversion kits Propane - Natural gas E-Series

Propane Conversion Kit Parts				
Gasket Gas valve - venturi	809000017	X	X	
Gasket Fitting 3/4" Gas valve	809000062	X	X	
EE-Prom E-Series	LPG 804000015 E75CP		LPG 804000016 E110CP	
Gas Conversion Sticker	E75CP		E110CP	
Conversion Kit label	8U340800	X	X	
Conversion Kit Data Label	E75CP		E110CP	
Instructions Sheets Conversion Kit	8U605100	X	X	
Propane orifice diameter	inch / mm	0.16" / 4.15	0.20" / 5.2	
Display indication at start-up	22t.P		32t.P	
Natural Gas Conversion Kit Parts				
Gasket Gas valve - venturi	809000017	X	X	
Gasket Fitting 3/4" Gas valve	809000062	X	X	
EE-Prom E-Series	NAT 804000023 E75CN		NAT 804000024 E110CN	
Gas Conversion Sticker	E75CN		E110CN	
Conversion Kit label	8U340700	X	X	
Conversion Kit Data Label	E75CN		E110CN	
Instructions Sheets Conversion Kit	8U605100	X	X	
Display indication at start-up	22t.1		32t.1	

17 Parts list vent system

Vent Products

Listed and Tested Vent Products for E75C, E110C, Q85S, Q130S, Q175S, Q175C and Q205S

Manufacturer	Descriptions	Parts #	
Heatfab	DGV 3"/5" Conc Air Intake Tee 3"	DGV03TAD3	
	Concentric	DGV 3"/5" Conc X 12" Length	DGV03L12
		DGV 3"/5" Conc X 31" Length	DGV03L36
		DGV 3"/5" Conc Horz Term Adapter	DGV03HT
		DGV 3"/5" Conc Vert Term Adapter	DGV03VT
		Rain Cap	SGV300
	Twin Pipe	3"- Adapter to fit into 80 mm Flue Collar	adapter
		3"- 12 Length	SGV302
		3"- 31" Length	SGV307
		3"- 90 Deg Tr Elbow	SGV314
		3"- Screen Termination	SGV392
		3"- Round Wall Thimble Plate	SGV393
		3"- Tall Cone Flashing, Flat- 2/12 Pitch	SGV3TCF
	Manufacturer	Descriptions	Parts #
IPEX	Concentric Vent Termination	1CT0303	
	PVC - FGV Concentric Kit	196006	
	PVC - FGV Wall Termination Kit	81219	
	CPVC - FGV Concentric Vent Kit	197009	
	Termination Vent Screen	196051	
Manufacturer	Descriptions	Parts #	
Simpson Dura-Vent	3" (76mm) SS flexible lining system	3SFLEX-XX 294590	
	3" (76mm) FasNSeal Flex-to-FasNSeal Adapter female	304003	
	3" (76mm) FasNSeal-to-FasNSeal Adapter Flexible male	304103	
	80mm to 3" Appliance Adapter	FSA-80MM3	
	Vertical termination	300325	
	3" (76mm) Bend 90 Degree	300160	
	3x5 AL294C Concentric (12" Straight Pipe)	35CVS-12	
	3x5 AL294C Concentric (36" Straight Pipe)	35CVS-36	
	3x5 AL294C Concentric (48" Straight Pipe)	35CVS-48	
	3x5 AL294C Concentric (90° Elbow)	35CVS-E90	
	3x5 AL294C Concentric (45° Elbow)	35CVS-E45	
	3x5 AL294C Concentric (Wall Strap)	35CVS-WS	
	3x5 AL294C Concentric (Horizontal Cap)	35CVS-HC	
	3x5 AL294C Concentric (Vertical Cap)	35CVS-VC	
	3x5 Sealed Combustion 6" Vent Length	SC-0603	
	3x5 Sealed Combustion 12" Vent Length	SC-1203	
	3x5 Sealed Combustion 18" Vent Length	SC-1803	
	3x5 Sealed Combustion 24" Vent Length	SC-2403	
	3x5 Sealed Combustion 36" Vent Length	SC-36-3	
	3x5 Sealed Combustion Adjustable Vent Length	SC-AVL3	
3x5 Sealed Combustion 94° Elbow	SC-94033		
Wall Kit (w/Cap)	FSSCWMK35		
Roof Kit (w/cap)	FSSCTRK35		
Manufacturer	Descriptions	Parts #	
Rinnai/ Ubbink	1 Meter Sections of PP/PVC, 3"/5"	224080	
	90 Degree, Male x Female, PP/PVC, 3"/5"	224078	
	Horizontal PP Termination, 21 inch	223175	
	Vertical PP Termination	184162	
	Condensing Raised Horizontal Termination Snorkel Kit	224047PP	
	Condensing 45 Deg. Vent Pipe Elbow 2 pcs	224077PP	
	Stainless Steel:	1 Meter Sections of SS/PVC, 3"/5"	224204SS
		90 Degree, Male x Female, SS/PVC, 3"/5"	224201SS
		Horizontal SS Termination, 21 inch	223178SS
		Vertical SS Termination	184221SS
Manufacturer	Descriptions	Parts #	
York International	3" PVC Concentric Vent Termination	1CT0303	
Miscellaneous			
Terminal	General PVC 1120 3" SCH 40 DWV ASTM D 2665 90 Elbow		
Air Intake Pipe	PVC 1120 3" SCH 40 DWV ASTM D 2665		
Vent Pipe	PVC 1120 3" SCH 40 DWV ASTM D 2665		

Vent Manufacturer Contact Information for Installation Instructions and Parts Lists:

Heat-Fab

Telephone: 800-772-0739
Fax: 413-863-4803
cystsvc@heat-fab.com
www.heatfab.com

IPEX

Telephone: 800-463-9572
905-403-0264
Fax: 905-403-9195
www.ipexamerica.com

Simpson Dura-Vent

Telephone: 518-463-7284
Fax: 518-463-5271
sales@duravent.com
www.protechinfo.com

Rinnai/Ubbink

Telephone: 800-621-9419
Fax: 678-829-1666
www.rinnai.us

York International

Telephone: 405-364-4040
877-874-7378
www.york.com/products/unitary/

18 Common venting guidelines

Do not common vent with the vent pipe of any other boiler or appliance. However, when an existing boiler is removed from a common venting system, the common venting system is likely to be too large for proper venting of the appliances remaining connected to it. At the time of removal of an existing boiler, the following steps shall be followed with each appliance remaining connected to the common venting system placed in operation, while the other appliances remaining connected to the common venting system are not in operation:

- (a) Seal any unused openings in the common venting system.
- (b) Visually inspect the venting system for proper size and horizontal pitch and determine there is no blockage or restriction, leakage, corrosion and other deficiencies which could cause an unsafe condition.
- (c) Insofar as is practical, close all building doors and windows and all doors between the space in which the appliances remaining connected to the common venting system are located and other spaces of the building. Turn on clothes dryers and any appliance not connected to the common venting system. Turn on any exhaust fans, such as range hoods and bathroom exhausts, so they will operate at maximum speed. Do not operate a summer exhaust fan. Close fireplace dampers.
- (d) Place in operation the appliance being inspected. Follow the lighting instructions. Adjust thermostat so appliance will operate continuously.
- (e) Test for spillage at the draft hood relief opening after 5 minutes of main burner operation. Use the flame of a match or candle, or smoke from a cigarette, cigar or pipe.
- (f) After it has been determined that each appliance remaining connected to the common venting system properly vents when tested as outlined above, return doors, windows, exhaust fans, fireplace dampers and any other gas burning appliance to their previous condition of use."
- (g) Any improper operation of the common venting system should be corrected so the installation conforms with the National Fuel Gas Code, ANSI Z223.1/NFPA 54 and/or CAN/CSA B149.1, Natural Gas and Propane Installation Code. When resizing any portion of the common venting system, the common venting system should be resized to approach the minimum size as determined using the appropriate tables in Part 11 of the National Fuel Gas Code, ANSI Z223.1/NFPA 54 and/or CAN/CSA B149.1, Natural Gas and Propane Installation Code.

Appendix A - Outdoor Reset Sensor Data

R 25 °C	12 kΩ
R 100 ° C	950 Ω
B _{25/85}	3750 K
Temperature coefficient	-4,2 %/K

Temp [°C]	NTC [kOhm]
-30	171.70
-20	98.82
-10	58.82
0	36.10
10	22.79
20	14.77
25	12.00
30	9.81
40	6.65
50	4.61
60	3.25
70	2.34
80	1.71
90	1.27
100	0.95
110	0.73
120	0.56

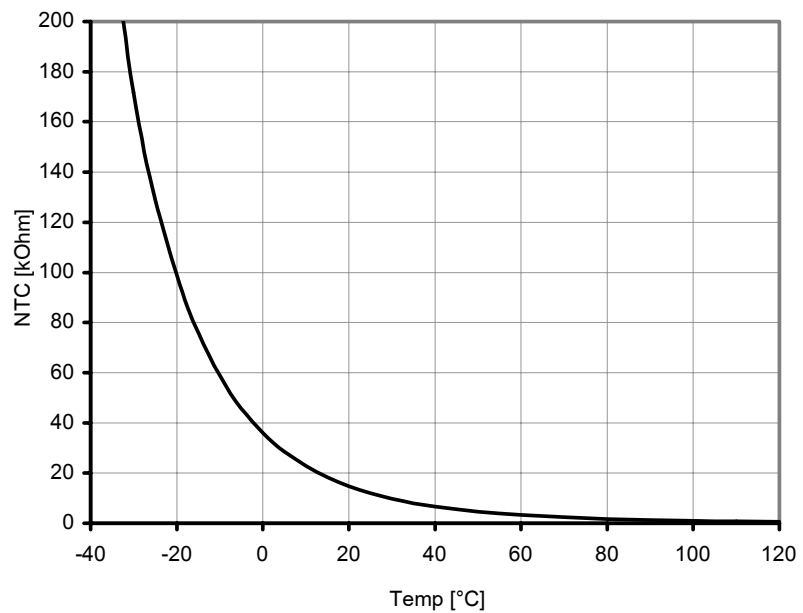

Appendix B - Resistance table NTC sensors

Temp °F	NTC 12K (12kΩ/77°F) supply sensor T1 return sensor T2 DHW sensor T3 outside sensor T4 flue gas sensor T5
------------	--

-4	98,000
-0.4	90,000
3.2	82,000
6.8	74,000
10.4	66,000
14	58,000
17.6	53,500
21.2	49,000
24.8	45,000
28.4	40,500
32	36,000
35.6	33,500
39.2	30,900
42.8	28,200
46.4	25,600
50	23,000
53.6	21,400
57.2	19,900
60.8	18,100
64.4	16,600
68	15,000
71.6	14,000
75.2	12,900
78.8	11,900
82.4	10,850
86	9,800
89.6	9,100
93.2	8,500
96.8	7,900
100.4	7,200
104	6,500
113	5,600
122	4,600
131	4,000
140	3,400
158	2,300
176	1,700
194	1,300

Resistance table NTC-Sensors

Rinnai®

EXPERIENCE OUR INNOVATION™

800000012 11/2011

Distributor for the USA

Rinnai America Corporate • 103 International Drive • Peachtree City, GA 30269
Toll Free: (800) 621-9419 • Tel: (678) 829-1700 • Fax: (678) 829-1666 • E-mail: info@rinnai.us • Internet: www.rinnai.us

E. & O. E.

This renewed publication cancels all previous installation instructions. The company reserves the right to change the specifications and dimensions without prior notice.