

G60UHV(X) SERIES UNITS

G60UHV(X) series units are mid-efficiency gas furnaces used for upflow or horizontal applications only, manufactured with Lennox Duralok Plus heat exchangers formed of aluminized steel. G60UH(X) units are available in heating capacities of 66,000 to 132,000 Btuh and cooling applications up to 5 tons. Refer to Engineering Handbook for proper sizing.

Units are factory equipped for use with natural gas. Kits are available for conversion to LPG operation. G60UH(X) model units are equipped with the Two-Stage / Variable Speed Integrated SureLight control. G60UH(X) unit meets the California Nitrogen Oxides (NO_x) Standards and California Seasonal Efficiency requirements. All units use a redundant gas valve to assure safety shut-off as required by C.S.A.

All specifications in this manual are subject to change. Procedures outlined in this manual are presented as a recommendation only and do not supersede or replace local or state codes. In the absence of local or state codes, the guidelines and procedures outlined in this manual (except where noted) are recommendations only and do not constitute code.

TABLE OF CONTENTS

Introduction	Page 1
Specifications	Page 2
Blower Data	Page 4
High Altitude	Page 7
I Unit Components	Page 9
II Installation	Page 31
III Start Up	Page 31
IV Heating System Service Checks	Page 32
V Typical Operating Characteristics	Page 34
VI Maintenance	Page 35
VII Wiring and Sequence of Operation	Page 37
VIII Field Wiring and Jumper Settings	Page 52
IX Troubleshooting	Page 57



⚠ IMPORTANT

Improper installation, adjustment, alteration, service or maintenance can cause property damage, personal injury or loss of life. Installation and service must be performed by a qualified installer, service agency or the gas supplier.

⚠ WARNING



Electric shock hazard. Can cause injury or death. Before attempting to perform any service or maintenance, turn the electrical power to unit OFF at disconnect switch(es). Unit may have multiple power supplies.

⚠ WARNING

Sharp edges. Be careful when servicing unit to avoid sharp edges which may result in personal injury.

SPECIFICATIONS

Gas Heating Performance	Model No. Low NOx Model No.	G60UHV-36A-070 G60UHV-36A-070X	G60UHV-36B-090 - - -	G60UHV-60C-090 G60UHV-60C-090X
Input - Btuh (kW) low fire		45,000 (13.2)	60,000 (17.6)	60,000 (17.6)
Output - Btuh (kW) low fire		36,000 (10.5)	48,000 (14.1)	48,000 (14.1)
Input - Btuh (kW) high fire		66,000 (19.3)	88,000 (5.8)	88,000 (25.8)
Output - Btuh (kW) high fire		54,000 (15.8)	72,000 (21.0)	72,000 (21.1)
☆AFUE		80.0%	80.0%	80.0%
California Seasonal Efficiency		77.2%	77.1%	76.8%
High static (CSA) - in. w.g. (Pa)		.80 (200)	.80 (200)	.80 (200)
Flue connection - in. (mm) round		4 (102)	4 (102)	4 (102)
Gas pipe size IPS - in. (mm)		1/2 (12.7)	1/2 (12.7)	1/2 (12.7)
Temperature rise range - °F (°C) low fire		20 - 50 (11 - 28)	20 - 50 (11 - 28)	15 - 45 (8 - 25)
Temperature rise range - °F (°C) high fire		40 - 70 (22 - 39)	40 - 70 (22 - 39)	30 - 60 (17 - 33)
Indoor Blower	Wheel nominal diameter x width - in. (mm)	10 x 8 (254 x 203)	10 x 8 (254 x 203)	11-1/2 x 10 (292 x 254)
	Motor output - hp (W)	1/2 (373)	1/2 (373)	1 (746)
	Tons (kW) of add-on cooling	2 - 3 (7.0 - 10.6)	2 - 3 (7.0 - 10.6)	4 - 5 (14.1 - 17.6)
Shipping weight - 1 package		137 (62)	154 (70)	172 (78)
Matching Coils	① Up-flow cased	C33-18A-2F, C33-24A-2F, C33-30A-2F, C33-36A-2F, C33-38A-2F	C33-24B-2F, C33-30B-2F, C33-36B-2F, C33-38B-2F, C33-42B-2F, C33-48B-2F	C33-36C-2F, C33-48C-2F, C33-50/60C-2F,
	Horizontal	CH33-18A-2F, CH33-24/30A-2F, CH33-36A-2F	CH33-36B-2F, CH33-42B-2F, CH33-44/48B-2F	CH33-36C-2F, CH33-48C-2F, CH33-50/60C-2F
Electrical characteristics		120 volts - 60 hertz - 1 phase (less than 12 amps)		
OPTIONAL ACCESSORIES - MUST BE ORDERED EXTRA				
③ Air Filter and Rack Kit Number and size of filters	Horizontal (end)	87L95 - (1) 14 x 25 x 1 in. (356 x 635 x 25 mm)	87L96 - (1) 18 x 25 x 1 in. (457 x 635 x 25 mm)	87L97 - (1) 20 x 25 x 1 in. (508 x 635 x 25 mm)
	④ Side Return	Single (44J22) or Ten Pack (66K63) - (1) 16 x 25 x 1 in. (406 x 635 x 25 mm)		
EZ Filter Base	Catalog Number - Shipping Weight	73P55 - 6 lbs. (3 kg)	73P56 - 7 lbs. (3 kg)	73P57 - 8 lbs. (4 kg)
	Dimensions - H x W x D	4 x 14-1/4 x 28-5/8 in. (102 x 362 x 727 mm)	4 x 17-5/8 x 28-5/8 in. (102 x 448 x 727 mm)	4 x 21-5/8 x 28-5/8 in. (102 x 549 x 727 mm)
	Number and size of filter (field provided)	14 x 25 x 1 in. (356 x 635 x 25 mm)	16 x 25 x 1 in. (406 x 635 x 25 mm)	20 x 25 x 1 in. (508 x 635 x 25 mm)
CCB1 Efficiency Plus™ Humidity Control System		35H00	35H00	35H00
High Altitude Pressure Switch Kit		See Page 7		
Horizontal Support Frame Kit - Shipping Weight		56J18 - 18 lbs. (8 kg)	56J18 - 18 lbs. (8 kg)	56J18 - 18 lbs. (8 kg)
LPG/Propane Kit		See Page 7		
RAB Return Air Base		- - -	- - -	RAB60C (12M71)
Vent Adaptor - 6 in. 152 (mm) connection size		18M79 - 2 lbs. (1 kg)	18M79 - 2 lbs. (1 kg)	18M79 - 2 lbs. (1 kg)

☆Annual Fuel Utilization Efficiency based on DOE test procedures and according to FTC labeling regulations. Isolated combustion system rating for non-weatherized furnaces. NOTE - Filters and provisions for mounting are not furnished and must be field provided.

① The same C33 uncased models match the furnaces shown but require an optional adaptor base or field fabricated transition. See C33 coil bulletin for additional information.

③ Cleanable polyurethane frame type filter.

④ Not for use with RAB Return Air Base or with 60C and 60D size units with 2nd stage heating air flow requirements of 1800 cfm (850 L/s) or greater. See Blower Performance Tables for additional information.

SPECIFICATIONS

Gas Heating Performance	Model No. Low NOx Model No.	G60UHV-60C-110 G60UHV-60C-110X	G60UHV-60D-135 ---
	Input - Btuh (kW) low fire	75,000 (22.0)	90,000 (26.4)
	Output - Btuh (kW) low fire	60,000 (17.6)	72,000 (21.1)
	Input - Btuh (kW) high fire	110,000 (32.2)	132,000 (38.7)
	Output - Btuh (kW) high fire	90,000 (26.4)	108,000 (31.6)
	☆AFUE	80.0%	80.0%
	California Seasonal Efficiency	77.2%	77.5%
	High static (CSA) - in. w.g. (Pa)	.80 (200)	.80 (200)
	Flue connection - in. (mm) round	4 (102)	4 (102)
	Gas pipe size IPS - in. (mm)	1/2 (12.7)	1/2 (12.7)
	Temperature rise range - °F (°C) low fire	25 - 55 (14 - 31)	25 - 55 (14 - 31)
	Temperature rise range - °F (°C) high fire	35 - 65 (19 - 36)	45 - 75 (25 - 42)
Indoor Blower	Wheel nominal diameter x width - in. (mm)	11-1/2 x 10 (292 x 254)	11-1/2 x 10 (292 x 254)
	Motor output - hp (W)	1 (746)	1 (746)
	Tons (kW) of add-on cooling	4 - 5 (14.1 - 17.6)	4 - 5 (14.1 - 17.6)
Shipping weight - 1 package		184 (83)	198 (90)
Matching Coils	□ Up-flow cased	C33-36C-2F, C33-48C-2F, C33-50/60C-2F,	C33-60D-2F, C33-62D-2F
	Horizontal	CH33-36C-2F, CH33-48C-2F, CH33-50/60C-2F	CH33-60D-2F, CH33-62D-2F
Electrical characteristics		120 volts - 60 hertz - 1 phase (less than 12 amps)	
OPTIONAL ACCESSORIES - MUST BE ORDERED EXTRA			
③ Air Filter and Rack Kit Number and size of filters	Horizontal (end)	87L97 (1) 20 x 25 x 1 in. (508 x 635 x 25 mm)	87L98 (1) 25 x 25 x 1 in. (635 x 635 x 25 mm)
	⑤ Side Return	Single 44J22 or Ten Pack (66K63) - (1) 16 x 25 x 1 (406 x 635 x 25)	
EZ Filter Base	Catalog Number - Shipping Weight	73P57 - 8 lbs. (4 kg)	73P58 - 10 lbs. (5 kg)
	Dimensions - H x W x D	4 x 21-5/8 x 28-5/8 in. (102 x 549 x 727 mm)	4 x 24-5/8 x 28-5/8 in. (102 x 625 x 727 mm)
	Number and size of field provided filter	(1) 20 x 25 x 1 in. (508 x 635 x 25 mm)	(1) 24 x 24 x 1 in. (610 x 610 x 25 mm)
CCB1 Efficiency Plus™ Humidity Control System		35H00	35H00
High Altitude Pressure Switch Kit		See Page 7	
Horizontal Support Frame Kit - Shipping Weight		56J18 - 18 lbs. (8 kg)	56J18 - 18 lbs. (8 kg)
LPG/Propane Kit		See Page 7	
RAB Return Air Base		RAB60C (12M71)	RAB60D (12M72)
Vent Adaptor - 6 in. 152 (mm) connection size		18M79 - 2 lbs. (1 kg)	18M79 - 2 lbs. (1 kg)

☆Annual Fuel Utilization Efficiency based on DOE test procedures and according to FTC labeling regulations. Isolated combustion system rating for non-weatherized furnaces.
NOTE - Filters and provisions for mounting are not furnished and must be field provided.

① The same C33 uncased models match the furnaces shown but require an optional adaptor base or field fabricated transition. See C33 coil bulletin for additional information.
③ Cleanable polyurethane frame type filter.

④ Flue connection on the unit is 4 in. (102 mm) diameter. Most applications will require 5 in. (127 mm) venting and field supplied 4 x 5 in. (102 x 127 mm) adaptor. See Venting Tables in the Installation Instructions for detailed information.

⑤ Not for use with RAB Return Air Base or with 60C and 60D size units with 2nd stage heating air flow requirements of 1800 cfm (850 L/s) or greater. See Blower Performance Tables for additional information.

BLOWER DATA

G60UHV-36A-070 BLOWER PERFORMANCE

0 through 0.80 in. w.g. (0 Through 200 Pa) External Static Pressure Range

Blower Control Factory Settings

ADJUST - NORM
HEAT - 2
COOL - 4

“ADJUST” Switch Positions	Speed Switch Positions															
	2nd Stage “HEAT” Speed								2nd Stage “COOL” Speed							
	1		2		3		4		1		2		3		4	
	cfm	L/s	cfm	L/s	cfm	L/s	cfm	L/s	cfm	L/s	cfm	L/s	cfm	L/s	cfm	L/s
“+” (Plus)	910	430	1055	495	1305	615	1350	635	1045	495	1230	580	1315	620	1420	670
“NORM” (Normal)	830	390	940	445	1165	550	1215	575	945	445	1100	520	1190	560	1300	615
“—” (Minus)	745	350	845	400	1030	485	1070	505	850	400	975	460	1035	485	1130	535

“ADJUST” Switch Positions	1st Stage “HEAT” Speed								1st Stage “COOL” Speed							
	1		2		3		4		1		2		3		4	
	cfm	L/s	cfm	L/s	cfm	L/s	cfm	L/s	cfm	L/s	cfm	L/s	cfm	L/s	cfm	L/s
“+” (Plus)	840	395	965	455	1195	565	1235	585	730	344	800	377	860	405	994	469
“NORM” (Normal)	765	360	865	410	1055	495	1105	520	680	320	745	351	780	368	850	401
“—” (Minus)	700	330	785	370	955	450	985	465	620	292	685	323	725	342	760	358

NOTES - The effect of static pressure and filter resistance is included in air volumes shown.
 1st stage HEAT is approximately **91%** of the same 2nd stage HEAT speed position.
 1st stage COOL (two speed air conditioning units only) is approximately **70%** (65% for units built prior to 09-2002) of the same 2nd stage COOL speed position.
 Continuous Fan Only speed is approximately **38%** of the same 2nd stage COOL speed position - minimum 500 cfm (235 L/s).
 Lennox Harmony II™ zone control applications - Minimum blower **heating** speed is approximately **75%** of the 1st stage HEAT speed position.
 Lennox Harmony II™ zone control applications - Minimum blower **cooling** speed is approximately **45%** of the 2nd stage COOL speed position.

G60UHV-36B-090 BLOWER PERFORMANCE

0 through 0.80 in. w.g. (0 Through 200 Pa) External Static Pressure Range

Blower Control Factory Settings

ADJUST - NORM
HEAT - 2
COOL - 4

“ADJUST” Switch Positions	Speed Switch Positions															
	2nd Stage “HEAT” Speed								2nd Stage “COOL” Speed							
	1		2		3		4		1		2		3		4	
	cfm	L/s	cfm	L/s	cfm	L/s	cfm	L/s	cfm	L/s	cfm	L/s	cfm	L/s	cfm	L/s
“+” (Plus)	N/A	N/A	1035	490	1280	605	1335	630	1010	475	1175	555	1275	600	1400	660
“NORM” (Normal)	N/A	N/A	930	440	1150	540	1190	560	935	440	1055	495	1130	535	1250	590
“—” (Minus)	N/A	N/A	830	390	1020	480	1050	495	830	390	940	445	1005	475	1090	515

“ADJUST” Switch Positions	1st Stage “HEAT” Speed								1st Stage “COOL” Speed							
	1		2		3		4		1		2		3		4	
	cfm	L/s	cfm	L/s	cfm	L/s	cfm	L/s	cfm	L/s	cfm	L/s	cfm	L/s	cfm	L/s
“+” (Plus)	N/A	N/A	935	440	1150	540	1195	565	740	349	800	377	850	401	910	429
“NORM” (Normal)	N/A	N/A	840	395	1035	490	1070	505	675	318	740	349	780	368	845	398
“—” (Minus)	N/A	N/A	755	355	930	440	965	455	615	290	690	325	715	337	750	353

NOTES - The effect of static pressure and filter resistance is included in air volumes shown.
 1st stage HEAT is approximately **91%** of the same 2nd stage HEAT speed position.
 1st stage COOL (two speed air conditioning units only) is approximately **70%** (65% for units built prior to 09-2002) of the same 2nd stage COOL speed position.
 Continuous Fan Only speed is approximately **38%** of the same 2nd stage COOL speed position - minimum 500 cfm (235 L/s).
 Lennox Harmony II™ zone control applications - Minimum blower **heating** speed is approximately **75%** of the 1st stage HEAT speed position.
 Lennox Harmony II™ zone control applications - Minimum blower **cooling** speed is approximately **45%** of the 2nd stage COOL speed position.
 N/A - 1st stage HEAT, speed position 1, cannot be used with this model.

G60UHV-60C-090 BLOWER PERFORMANCE

0 through 0.80 in. w.g. (0 Through 200 Pa) External Static Pressure Range

Bottom Return Air, Side Return Air with Optional RAB Return Air Base, Return Air from Both Sides or Return Air from Bottom and One Side.

Blower Control Factory Settings

ADJUST - NORM
HEAT - 2
COOL - 4

“ADJUST” Switch Positions	Speed Switch Positions															
	2nd Stage “HEAT” Speed								2nd Stage “COOL” Speed							
	1		2		3		4		1		2		3		4	
	cfm	L/s	cfm	L/s	cfm	L/s	cfm	L/s	cfm	L/s	cfm	L/s	cfm	L/s	cfm	L/s
“+” (Plus)	1525	720	1715	810	1935	915	2125	1005	1630	770	1760	830	1960	925	2185	1030
“NORM” (Normal)	1385	655	1560	735	1760	830	1930	910	1480	700	1600	755	1785	840	1985	935
“—” (Minus)	1245	590	1400	660	1580	745	1740	820	1335	630	1440	680	1605	755	1785	845

“ADJUST” Switch Positions	1st Stage “HEAT” Speed								1st Stage “COOL” Speed							
	1		2		3		4		1		2		3		4	
	cfm	L/s	cfm	L/s	cfm	L/s	cfm	L/s	cfm	L/s	cfm	L/s	cfm	L/s	cfm	L/s
“+” (Plus)	1395	660	1580	745	1780	840	1960	925	1120	528	1200	566	1370	646	1550	731
“NORM” (Normal)	1265	595	1440	680	1615	760	1780	840	1000	471	1100	519	1250	589	1375	648
“—” (Minus)	1140	540	1295	610	1465	690	1605	755	900	424	975	460	1120	528	1230	580

NOTES - The effect of static pressure and filter resistance is included in air volumes shown.
 1st stage HEAT is approximately **91%** of the same 2nd stage HEAT speed position.
 1st stage COOL (two speed air conditioning units only) is approximately **70%** (60% for units built prior to 09-2002) of the same 2nd stage COOL speed position.
 Continuous Fan Only speed is approximately **38%** of the same 2nd stage COOL speed position.
 Lennox Harmony II™ zone control applications - Minimum blower **heating** speed is approximately **75%** of the 1st stage HEAT speed position.
 Lennox Harmony II™ zone control applications - Minimum blower **cooling** speed is approximately **42%** of the 2nd stage COOL speed position.

BLOWER DATA

G60UHV-60C-090 BLOWER PERFORMANCE																
0 through 0.80 in. w.g. (0 Through 200 Pa) External Static Pressure Range																
Single Side Return Air - Air volumes in bold require field fabricated transition to accommodate 20 x 25 x 1 in. (508 x 635 x 25 mm) cleanable air filter in order to maintain proper air velocity across the filter.																
Blower Control Factory Settings						ADJUST - NORM HEAT - 2 COOL - 4										
“ADJUST” Switch Positions	Speed Switch Positions															
	2nd Stage “HEAT” Speed								2nd Stage “COOL” Speed							
	1		2		3		4		1		2		3		4	
	cfm	L/s	cfm	L/s	cfm	L/s	cfm	L/s	cfm	L/s	cfm	L/s	cfm	L/s	cfm	L/s
“+” (Plus)	1475	695	1665	785	1870	880	2050	965	1580	745	1700	800	1920	905	2110	995
“NORM” (Normal)	1340	630	1515	715	1700	800	1865	880	1435	675	1545	730	1745	825	1920	905
“—” (Minus)	1205	570	1365	645	1530	720	1680	790	1290	610	1390	655	1570	740	1730	815
“ADJUST” Switch Positions	1st Stage “HEAT” Speed								1st Stage “COOL” Speed							
	1		2		3		4		1		2		3		4	
	cfm	L/s	cfm	L/s	cfm	L/s	cfm	L/s	cfm	L/s	cfm	L/s	cfm	L/s	cfm	L/s
“+” (Plus)	1355	640	1535	725	1710	805	1890	890	1070	504	1160	547	1325	625	1490	703
“NORM” (Normal)	1230	580	1395	660	1555	735	1720	810	955	450	1060	500	1210	570	1325	625
“—” (Minus)	1105	520	1255	590	1400	660	1550	730	860	405	935	441	1085	512	1185	559

NOTES - The effect of static pressure and filter resistance is included in air volumes shown.
 1st stage HEAT is approximately **91%** of the same 2nd stage HEAT speed position.
 1st stage COOL (two speed air conditioning units only) is approximately **70%** (**60%** for units built prior to 09-2002) of the same 2nd stage COOL speed position.
 Continuous Fan Only speed is approximately **38%** of the same 2nd stage COOL speed position.
 Lennox Harmony II™ zone control applications - Minimum blower **heating** speed is approximately **75%** of the 1st stage HEAT speed position.
 Lennox Harmony II™ zone control applications - Minimum blower **cooling** speed is approximately **42%** of the 2nd stage COOL speed position.

G60UHV-60C-110 BLOWER PERFORMANCE																
0 through 0.80 in. w.g. (0 Through 200 Pa) External Static Pressure Range																
Bottom Return Air, Side Return Air with Optional RAB Return Air Base, Return Air from Both Sides or Return Air from Bottom and One Side.																
Blower Control Factory Settings						ADJUST - NORM HEAT - 2 COOL - 4										
“ADJUST” Switch Positions	Speed Switch Positions															
	2nd Stage “HEAT” Speed								2nd Stage “COOL” Speed							
	1		2		3		4		1		2		3		4	
	cfm	L/s	cfm	L/s	cfm	L/s	cfm	L/s	cfm	L/s	cfm	L/s	cfm	L/s	cfm	L/s
“+” (Plus)	1485	700	1695	800	1910	900	2130	1005	1630	770	1750	825	1980	935	2185	1030
“NORM” (Normal)	1350	635	1540	730	1735	820	1935	915	1480	700	1590	750	1800	850	1985	940
“—” (Minus)	1215	575	1390	655	1560	735	1740	820	1335	630	1435	675	1620	765	1790	845
“ADJUST” Switch Positions	1st Stage “HEAT” Speed								1st Stage “COOL” Speed							
	1		2		3		4		1		2		3		4	
	cfm	L/s	cfm	L/s	cfm	L/s	cfm	L/s	cfm	L/s	cfm	L/s	cfm	L/s	cfm	L/s
“+” (Plus)	1365	645	1550	730	1735	820	1925	910	1080	509	1075	507	1315	620	1445	681
“NORM” (Normal)	1240	585	1410	665	1575	745	1750	825	990	467	1050	495	1195	563	1315	620
“—” (Minus)	1115	525	1270	600	1420	670	1575	745	890	419	940	443	1075	507	1195	563

NOTES - The effect of static pressure and filter resistance is included in air volumes shown.
 1st stage HEAT is approximately **91%** of the same 2nd stage HEAT speed position.
 1st stage COOL (two speed air conditioning units only) is approximately **70%** (**60%** for units built prior to 09-2002) of the same 2nd stage COOL speed position.
 Continuous Fan Only speed is approximately **38%** of the same 2nd stage COOL speed position.
 Lennox Harmony II™ zone control applications - Minimum blower **heating** speed is approximately **75%** of the 1st stage HEAT speed position.
 Lennox Harmony II™ zone control applications - Minimum blower **cooling** speed is approximately **42%** of the 2nd stage COOL speed position.

BLOWER DATA

G60UHV-60C-110 BLOWER PERFORMANCE

0 through 0.80 in. w.g. (0 Through 200 Pa) External Static Pressure Range

Single Side Return Air - Air volumes in bold require field fabricated transition to accommodate 20 x 25 x 1 in. (508 x 635 x 25 mm) cleanable air filter in order to maintain proper air velocity across the filter.

Blower Control Factory Settings

**ADJUST - NORM
HEAT - 2
COOL - 4**

“ADJUST” Switch Positions	Speed Switch Positions															
	2nd Stage “HEAT” Speed								2nd Stage “COOL” Speed							
	1		2		3		4		1		2		3		4	
	cfm	L/s	cfm	L/s	cfm	L/s	cfm	L/s	cfm	L/s	cfm	L/s	cfm	L/s	cfm	L/s
“+” (Plus)	1430	675	1615	765	1835	865	2040	965	1530	720	1660	785	1875	885	2100	990
“NORM” (Normal)	1300	615	1470	695	1665	785	1855	875	1390	655	1510	715	1705	805	1910	900
“—” (Minus)	1170	550	1325	625	1500	710	1670	790	1250	590	1360	640	1535	725	1720	810

“ADJUST” Switch Positions	1st Stage “HEAT” Speed								1st Stage “COOL” Speed							
	1		2		3		4		1		2		3		4	
	cfm	L/s	cfm	L/s	cfm	L/s	cfm	L/s	cfm	L/s	cfm	L/s	cfm	L/s	cfm	L/s
“+” (Plus)	1305	615	1480	700	1680	790	1865	880	965	455	1060	500	1205	568	1345	634
“NORM” (Normal)	1185	560	1345	635	1525	720	1695	800	885	417	965	455	995	469	1225	578
“—” (Minus)	1065	505	1210	570	1375	650	1525	720	795	375	875	412	985	464	1115	526

NOTES - The effect of static pressure and filter resistance is included in air volumes shown.

1st stage HEAT is approximately **91%** of the same 2nd stage HEAT speed position.

1st stage COOL (two speed air conditioning units only) is approximately **70%** (**60%** for units built prior to 09-2002) of the same 2nd stage COOL speed position.

Continuous Fan Only speed is approximately **38%** of the same 2nd stage COOL speed position.

Lennox Harmony II™ zone control applications - Minimum blower **heating** speed is approximately **75%** of the 1st stage HEAT speed position.

Lennox Harmony II™ zone control applications - Minimum blower **cooling** speed is approximately **42%** of the 2nd stage COOL speed position.

G60UHV-60D-135 BLOWER PERFORMANCE

0 through 0.80 in. w.g. (0 Through 200 Pa) External Static Pressure Range

Bottom Return Air, Side Return Air with Optional RAB Return Air Base, Return Air from Both Sides or Return Air from Bottom and One Side.

Blower Control Factory Settings

**ADJUST - NORM
HEAT - 2
COOL - 4**

“ADJUST” Switch Positions	Speed Switch Positions															
	2nd Stage “HEAT” Speed								2nd Stage “COOL” Speed							
	1		2		3		4		1		2		3		4	
	cfm	L/s	cfm	L/s	cfm	L/s	cfm	L/s	cfm	L/s	cfm	L/s	cfm	L/s	cfm	L/s
“+” (Plus)	1520	715	1725	815	1940	915	2130	1005	1630	770	1760	830	1985	935	2200	1040
“NORM” (Normal)	1385	655	1570	740	1765	835	1940	915	1480	700	1600	755	1805	850	2000	945
“—” (Minus)	N/A	N/A	1410	665	1590	750	1745	825	1335	630	1440	680	1625	765	1800	850

“ADJUST” Switch Positions	1st Stage “HEAT” Speed								1st Stage “COOL” Speed							
	1		2		3		4		1		2		3		4	
	cfm	L/s	cfm	L/s	cfm	L/s	cfm	L/s	cfm	L/s	cfm	L/s	cfm	L/s	cfm	L/s
“+” (Plus)	1395	660	1580	745	1760	830	1960	925	1090	514	1170	552	1315	620	1450	684
“NORM” (Normal)	1265	595	1435	675	1600	755	1785	840	995	469	1060	500	1200	566	1320	622
“—” (Minus)	N/A	N/A	1295	610	1440	680	1605	755	895	422	950	448	1080	509	1200	566

NOTES - The effect of static pressure and filter resistance is included in air volumes shown.

1st stage HEAT is approximately **91%** of the same 2nd stage HEAT speed position.

1st stage COOL (two speed air conditioning units only) is approximately **70%** (**65%** for units built prior to 09-2009) of the same 2nd stage COOL speed position.

Continuous Fan Only speed is approximately **38%** of the same 2nd stage COOL speed position.

Lennox Harmony II™ zone control applications - Minimum blower **heating** speed is approximately **75%** of the 1st stage HEAT speed position.

Lennox Harmony II™ zone control applications - Minimum blower **cooling** speed is approximately **45%** of the 2nd stage COOL speed position.

N/A - 1st stage HEAT, speed position 1 with “—” (Minus) “Adjust” setting, cannot be used with this model.

BLOWER DATA

G60UHV-60D-135 BLOWER PERFORMANCE																
0 through 0.80 in. w.g. (0 Through 200 Pa) External Static Pressure Range																
Single Side Return Air - Air volumes in bold require field fabricated transition to accommodate 20 x 25 x 1 in. (508 x 635 x 25 mm) cleanable air filter in order to maintain proper air velocity across the filter.																
Blower Control Factory Settings ADJUST - NORM HEAT - 2 COOL - 4																
“ADJUST” Switch Positions	Speed Switch Positions															
	2nd Stage “HEAT” Speed								2nd Stage “COOL” Speed							
	1		2		3		4		1		2		3		4	
	cfm	L/s	cfm	L/s	cfm	L/s	cfm	L/s	cfm	L/s	cfm	L/s	cfm	L/s	cfm	L/s
“+” (Plus)	1415	665	1625	765	1820	860	2015	950	1525	720	1650	780	1875	885	2095	990
“NORM” (Normal)	1285	605	1475	695	1655	780	1830	865	1385	655	1500	710	1705	805	1905	900
“—” (Minus)	N/A	N/A	1330	625	1490	705	1645	775	1245	590	1350	635	1535	725	1715	810
“ADJUST” Switch Positions	1st Stage “HEAT” Speed								1st Stage “COOL” Speed							
	1		2		3		4		1		2		3		4	
	cfm	L/s	cfm	L/s	cfm	L/s	cfm	L/s	cfm	L/s	cfm	L/s	cfm	L/s	cfm	L/s
“+” (Plus)	1300	615	1480	700	1660	785	1850	875	965	455	1070	504	1215	573	1345	634
“NORM” (Normal)	1180	555	1345	635	1510	715	1680	795	885	417	975	460	1105	521	1225	578
“—” (Minus)	N/A	N/A	1210	570	1360	640	1510	715	795	375	870	410	995	469	1115	526

NOTES - The effect of static pressure and filter resistance is included in air volumes shown.
 1st stage HEAT is approximately **91%** of the same 2nd stage HEAT speed position.
 1st stage COOL (two speed air conditioning units only) is approximately **70%** (65% for units built prior to 09-2002) of the same 2nd stage COOL speed position.
 Continuous Fan Only speed is approximately **38%** of the same 2nd stage COOL speed position.
 Lennox Harmony II™ zone control applications - Minimum blower **heating** speed is approximately 75% of the 1st stage HEAT speed position.
 Lennox Harmony II™ zone control applications - Minimum blower **cooling** speed is approximately **45%** of the 2nd stage COOL speed position.
 N/A - 1st stage HEAT, speed position 1 with “—” (Minus) “Adjust” setting, cannot be used with this model.

FILTER AIR RESISTANCE			
cfm	L/s	in. w.g.	Pa
0	0	0.00	0
200	95	0.01	0
400	190	0.03	5
600	285	0.04	10
800	380	0.06	15
1000	470	0.09	20
1200	565	0.12	30
1400	660	0.15	35
1600	755	0.19	45
1800	850	0.23	55
2000	945	0.27	65
2200	1040	0.33	80
2400	1130	0.38	95
2600	1225	0.44	110

HIGH ALTITUDE

Model Input Size	Gas	Altitude						Manifold Pressure at all altitudes			
		0 - 4500 ft. (0 - 1372 m)		4,501 - 7500 ft. (1373 - 2286 m)		7501-10,000 ft. (2286 - 3048 m)		Low Fire		High Fire	
		Required Conversion Kit	Pressure Switch	Required Conversion Kit	Pressure Switch	Required Conversion Kit	Pressure Switch	in. w.g.	kPa	in. w.g.	kPa
070-1 to -6	Nat.	N/A	No Change	N/A	No Change	59M16	18M64	1.7	0.42	3.5	0.87
	LPG	59M13	No Change	59M13	No Change	59M14	18M64	4.9	1.22	10.0	2.5
090-1 to -6	Nat.	N/A	No Change	N/A	18M61	59M16	18M64	1.7	0.42	3.5	0.87
	LPG	59M13	No Change	59M13	18M61	59M14	18M64	4.9	1.22	10.0	2.5
110/135-1 to -6	Nat.	N/A	No Change	N/A	18M63	59M16	18M61	1.7	0.42	3.5	0.87
	LPG	59M13	No Change	59M13	18M63	59M14	18M61	4.9	1.22	10.0	2.5
070-7 and later	Nat.	N/A	No Change	N/A	No Change	59M17	18M64	1.7	0.42	3.5	0.87
	LPG	59M13	No Change	59M13	No Change	59M14	18M64	4.9	1.22	10.0	2.5
090-7 and later	Nat.	N/A	No Change	N/A	18M61	59M17	18M64	1.7	0.42	3.5	0.87
	LPG	59M13	No Change	59M13	18M61	59M14	18M64	4.9	1.22	10.0	2.5
110/135-7 and later	Nat.	N/A	No Change	N/A	18M63	59M17	18M61	1.7	0.42	3.5	0.87
	LPG	59M13	No Change	59M13	18M63	59M14	18M61	4.9	1.22	10.0	2.5

Pressure switch is factory set. No adjustment necessary. All models use the factory installed pressure switch from 0-4500 feet (0-1370 m).

G60UHV(X) PARTS ARRANGEMENT

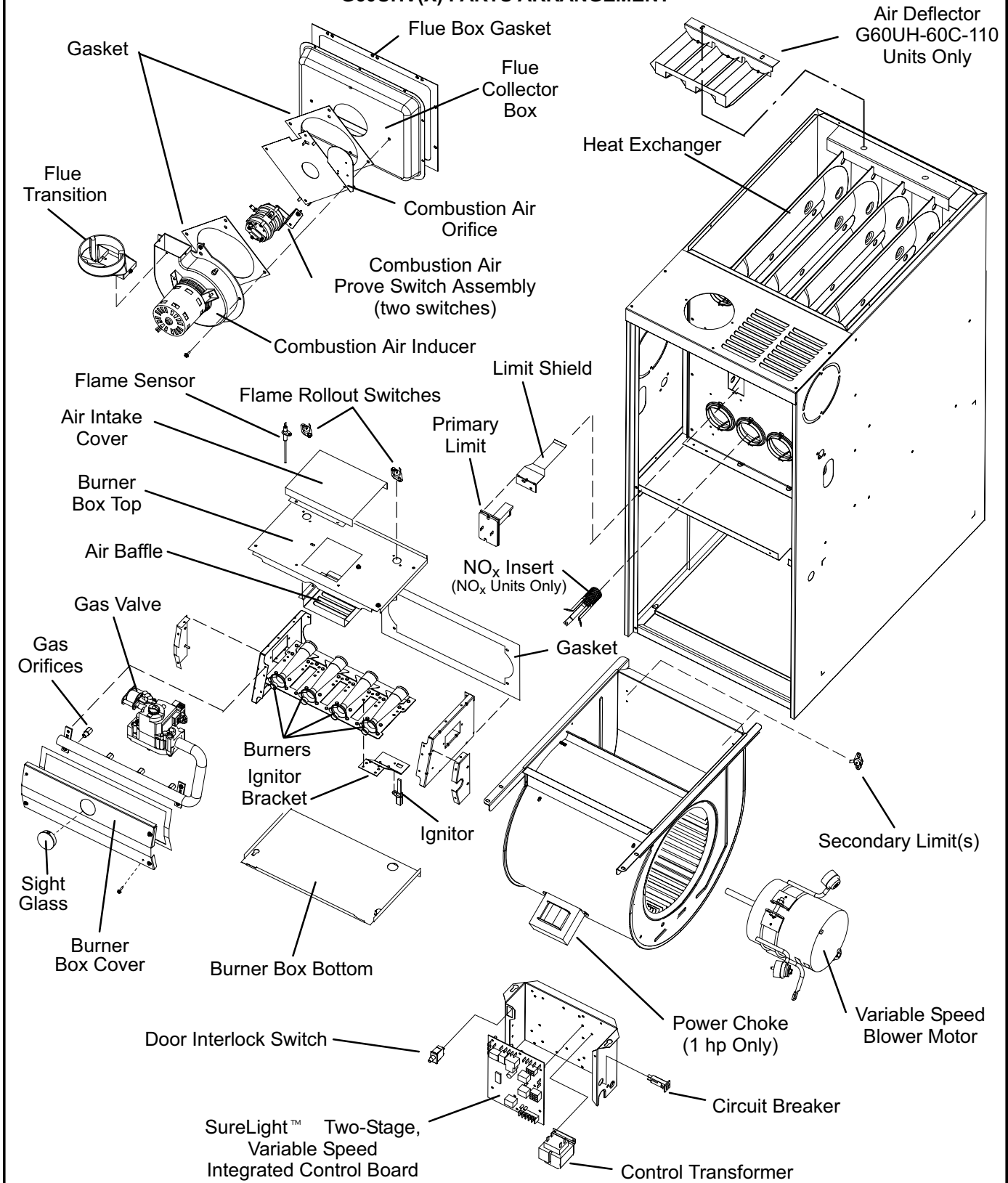

FIGURE 1

I-UNIT COMPONENTS

G60UHV(X) unit components are shown in figure 1. The gas valve, combustion air inducer and burners can be accessed by removing the burner access panel. Electrical components are in the control box (figure 2) found in the blower section.

G60UHV(X) units are factory equipped with a bottom return air panel in place. The panel is designed to be field removed as required for bottom air return. Markings are provided for side return air and may be cut out in the field.

ELECTROSTATIC DISCHARGE (ESD) Precautions and Procedures

⚠ CAUTION

Electrostatic discharge can affect electronic components. Take precautions during furnace installation and service to protect the furnace's electronic controls. Precautions will help to avoid control exposure to electrostatic discharge by putting the furnace, the control and the technician at the same electrostatic potential. Neutralize electrostatic charge by touching hand and all tools on an unpainted unit surface, such as the gas valve or blower deck, before performing any service procedure.

1. Control Transformer (T1)

A transformer located in the control box provides power to the low voltage section of the unit. Transformers on all models are rated 40VA with a 120V primary and a 24V secondary.

2. Door Interlock Switch (S51)

A door interlock switch rated 14A at 125VAC is wired in series with line voltage. When the blower door is removed the unit will shut down.

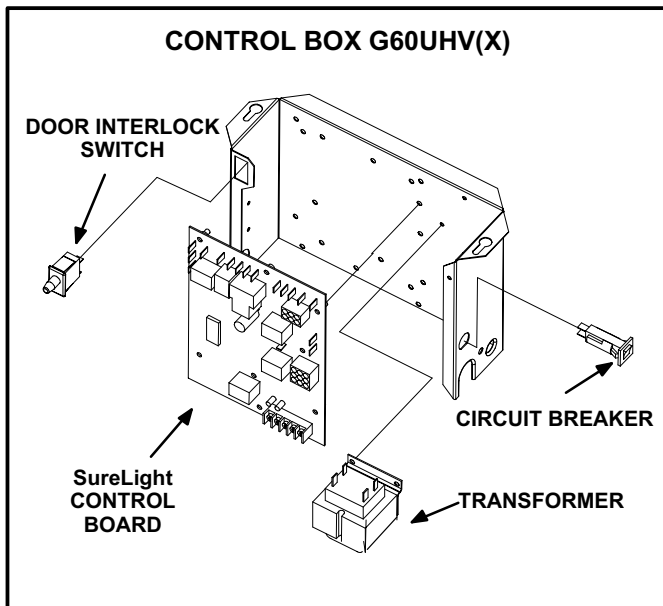

FIGURE 2

3. Circuit Breaker (CB8)

A 24V circuit breaker is also located in the control box. The switch provides overcurrent protection to the transformer (T1). The breaker is rated 3A at 32V. If the current exceeds this limit the breaker will trip and all unit operation will shutdown. The breaker can be manually reset by pressing the button on the face. See figure 3.

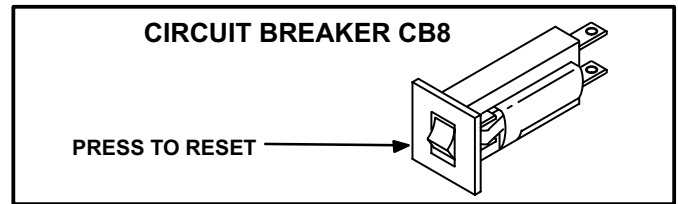

FIGURE 3

⚠ WARNING

Shock hazard.

Disconnect power before servicing. Integrated Control Board is not field repairable. If control is inoperable, simply replace entire control.

Can cause injury or death. Unsafe operation will result if repair is attempted.

4. Integrated Control Board(A92) Boards 18M99 and 49M59

All G60UHV units are equipped with the Lennox two-stage, variable speed integrated SureLight control board. The system consists of a ignition / blower control board (figure 4 with control terminal designations in tables 1 through 4) and ignitor (figure 11). The board and ignitor work in combination to ensure furnace ignition and ignitor durability. The SureLight integrated board controls all major furnace operations. The board features two LED lights, DS1 and DS2 for troubleshooting and four LED lights (DS3, DS6, DS7 and DS8) to show furnace status. The board also has two accessory terminals rated at (1) one amp each. See table 5 for status code and table 6 for troubleshooting diagnostic codes.

Electronic Ignition

At the beginning of the heat cycle the SureLight control monitors the first stage and second stage combustion air inducer prove switch. The control will not begin the heating cycle if the first stage prove switch is closed (by-passed). Likewise the control will not begin the second stage heating cycle if the second stage prove switch is closed, and will remain in first stage heat. However, if the second stage prove switch closes during the first stage heat pre-purge, the control will allow second stage heat. Once the first stage prove switch is determined to be open, the combustion air inducer is energized on low (first stage) heat speed. When the differential in the prove switch is great enough, the prove switch closes and a 15-second pre-purge begins. If the switch is not proven within 2-1/2 minutes, the control goes into Watchguard-Pressure Switch mode for a 5-minute reset period.

After the 15-second pre-purge period, the SureLight ignitor warms up for 20 seconds after which the gas valve opens for a 4-second trial for ignition. The ignitor energizes during the trial until flame is sensed. If ignition is not proved during the 4-second period, the control will try four more times with an inter-purge and warm-up time between trials of 35 seconds. After a total of five trials for ignition (including the initial trial), the control goes into Watchguard-Flame Failure mode. After a 60-minute reset period, the control will begin the ignition sequence again.

The SureLight control board has an added feature that prolongs the life of the ignitor. After a successful ignition, the SureLight control utilizes less power to energize the ignitor on successive calls for heat. The control continues to ramp down the voltage to the ignitor until it finds the lowest amount of power that will provide a successful ignition. This amount of power is used for 255 cycles. On the 256th call for heat, the control will again ramp down until the lowest power is determined and the cycle begins again.

Two Stage Operation / Thermostat Selection Jumper

The control can be utilized in two modes: SINGLE-STAGE thermostat or TWO-STAGE thermostat. The thermostat selection jumper E20, located just below dip switches 1 through 3 (figure 4), must be positioned for the particular application. The jumper is factory set on "TWO" for use with a two-stage thermostat with two stage heat. Re-position jumper to "SINGLE" for use with a single stage thermostat with two stage heat.

While in the single-stage thermostat mode (*single* jumper setting), the burners will always fire on first-stage heat. The combustion air inducer will operate on low speed and indoor blower will operate on low heat speed. After a 10 minute recognition period, the unit will switch to second stage heat. While in the two-stage thermostat mode (*two* jumper setting) the burners will fire on first-stage heat. The combustion air inducer will operate on low speed and indoor blower will operate on low heat speed. The unit will switch to second-stage heat on call from the indoor thermostat. If there is a simultaneous call for first and second stage heat, the unit will fire an first stage heat and switch to second stage heat after 30 seconds of operation. See Sequence of Operation flow charts in the back of this manual for more detail.

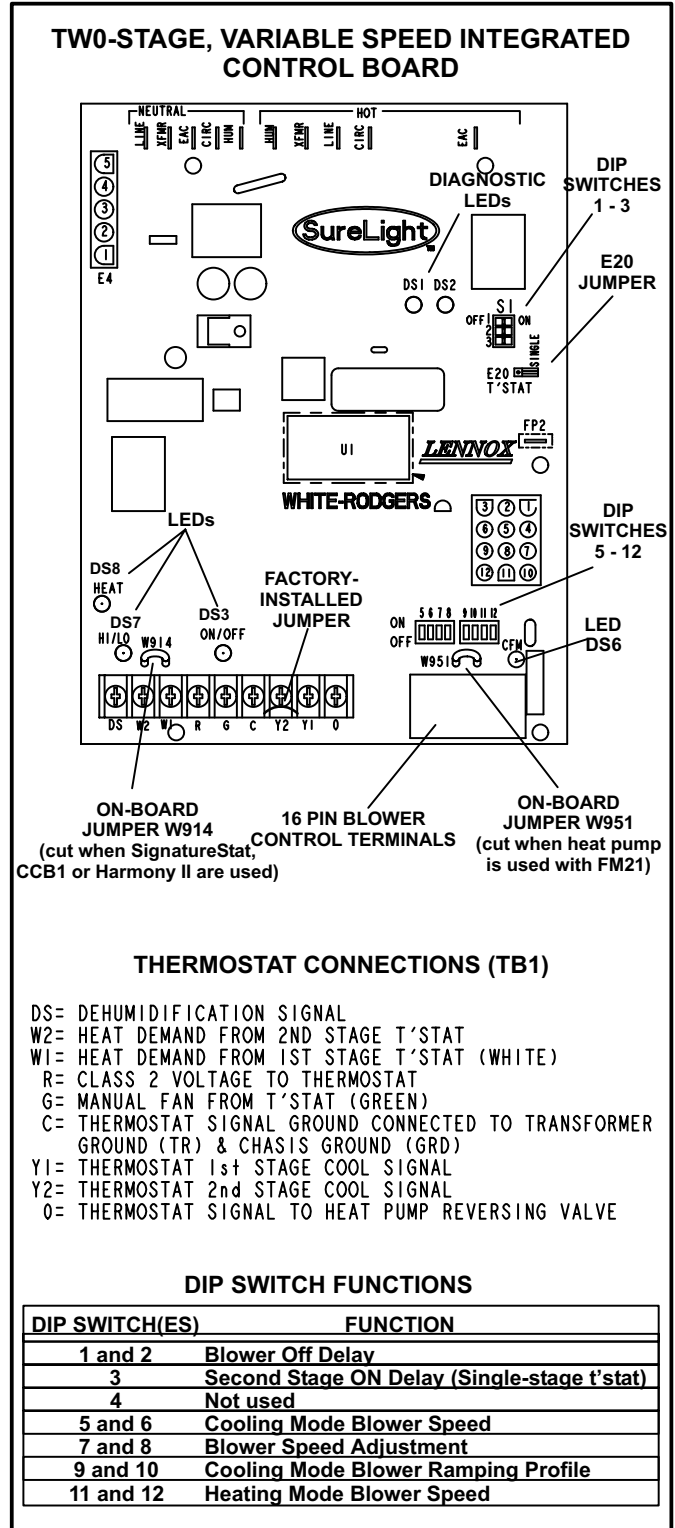

FIGURE 4

TABLE 1

Two Stage Ignition / Blower Control Terminals	
LINE	Line 120VAC Neutral
XFMR	Transformer 120VAC Neutral
EAC	Electronic Air Cleaner 120VAC Neutral
CIRC	Indoor Blower 120VAC Neutral
HUM	Humidifier 120VAC Neutral
HUM	Humidifier 120VAC Hot
XMFR	Transformer 120VAC Hot
LINE	Line 120VAC Hot
CIRC	Indoor Blower 120VAC Hot
EAC	Electronic Air Cleaner 120VAC Hot

TABLE 2

SureLight Board 5 Pin Terminal Designation	
PIN #	Function
1	Ignitor
2	Combustion Air Inducer High Speed
3	Combustion Air Inducer Low Speed
4	Combustion Air Inducer Neutral
5	Ignitor Neutral

TABLE 3

SureLight Board 12Pin Terminal Designation	
PIN #	Function
1	Gas Valve High Fire
2	Second Stage Pressure Switch
3	Not Used
4	Ground
5	24V Hot
6	Primary Limit In
7	Gas Valve Low Stage
8	Gas Valve Common
9	24V Neutral
10	Ground
11	Primary Limit Out
12	1st Stage Pressure Switch

TABLE 4

SureLight Board 16 Pin Blower Control Terminals	
PIN #	Function
1	Ground
2	Low Heat Speed
3	Ground
4	"DELAY" Dip Switch Selection
5	"COOL" Dip Switch Selection
6	"Y1" Signal
7	"ADJUST" Dip Switch Selection
8	Ground
9	"0" From Thermostat
10	"DS" Output Signal
11	"HEAT" Dip Switch Selection
12	24 VAC
13	HIGH HEAT Speed
14	"Y2" Signal
15	"G"
16	CFM LED

TABLE 5**STATUS CODES**

STATUS LED	COLOR	FUNCTION
DS3 "ON / OFF"	GREEN	DS3-ON indicates that the motor has a demand to operate. (This LED must be on in all modes).
DS6 "CFM"	GREEN	DS6-blinking indicates the airflow (CFM) demand in the motor. The air flow is determine by counting blinks between two (2) second pauses. One blink equals roughly 100 CFM.
DS7 "HI / LO"	YELLOW	DS7-ON indicates the "DS to R" jumper has not been cut. When the jumper is cut the system will be operating with LENNOX HARMONY II™ (See Harmony Installation Instructions) or with the CCB1 Efficiency Plus control. CCB1: When ON, a 24 VAC is being applied and when OFF, it has been removed. This on/off operation varies the indoor blower's performance so dehumidification can be enhanced.
DS8 "HEAT"	YELLOW	DS8-ON indicates the sytem is in HEAT mode.

TABLE 6**DIAGNOSTIC CODES**

Diagnostic LEDs are labeled DS1 and DS2. See figure 4 for location of diagnostic LEDs.

DS1	DS2	DESCRIPTION
SIMULTANEOUS SLOW FLASH	SIMULTANEOUS SLOW FLASH	Power on - Normal operation. Also signaled during cooling and continuous fan.
SIMULTANEOUS FAST FLASH	SIMULTANEOUS FAST FLASH	Normal operation - signaled when heating demand initiated at thermostat.
SLOW FLASH	ON	Primary, secondary or rollout limit switch open. Limits must close within 3 minutes or unit goes into 1 hour Watchguard.
OFF	SLOW FLASH	Low prove switch open; OR: Blocked inlet/exhaust vent; OR: Low prove switch closed prior to activation of combustion air inducer.
OFF	FAST FLASH	High prove switch open; OR: Blocked inlet/exhaust vent; OR: High prove switch closed prior to activation of combustion air inducer.
ALTERNATING SLOW FLASH	ALTERNATING SLOW FLASH	Watchguard -- burners failed to ignite; OR limit open more than 3 minutes; OR lost flame sense 5 times in one heating cycle; OR prove switch opened 5 times in one heating cycle.
SLOW FLASH	OFF	Flame sensed without gas valve energized.
ON ON OFF	ON OFF ON	Circuit board failure or control wired incorrectly. Check 24 and 115 volts to board.
FAST FLASH	SLOW FLASH	Main power polarity reversed. Switch line and neutral.
SLOW FLASH	FAST FLASH	Low flame signal. Measures below 0.23 microAmps. Replace flame sense rod.
ALTERNATING FAST FLASH	ALTERNATING FAST FLASH	The following conditions are sensed during the ignitor warm-up period only: 1) Improper main ground; 2) Broken ignitor; OR: Open ignitor circuit; 3) Line voltage below 75 volts. (If voltage lower than 75 volts prior to ignitor warm-up, control will signal waiting on call from thermostat, and will not respond.

NOTE - Slow flash rate equals 1 Hz (one flash per second). Fast flash rate equals 3 Hz (three flashes per second). Low flame sense current = 0.17 - .22 microAmps.

Dip Switch Settings

Switches 1 and 2 -- Blower Off Delay -- The blower-on delay of 45 seconds is not adjustable. The blower-off delay (time that the blower operates after the heating demand has been satisfied) can be adjusted by moving switches 1 and 2 on the integrated control board. The unit is shipped from the factory with a blower-off delay of 90 seconds. The blower off delay affects comfort and is adjustable to satisfy individual applications. Adjust the blower off delay to achieve a supply air temperature between 90° and 110°F at the exact moment that the blower is de-energized. Longer off delay settings provide lower supply air temperatures; shorter settings provide higher supply air temperatures. The table below provides the blower off timings that will result from different switch settings.

**TABLE 7
Blower Off Delay Switch Settings**

Blower Off Delay (Seconds)	Switch 1	Switch 2
60	Off	Off
90	Off	On
120	On	Off
180	On	On

Switch 3 -- Second Stage Delay (Used with Single-Stage Thermostat Only) -- This switch is used to determine the second stage on delay when a single-stage thermostat is being used. The switch is factory-set in the ON position, which provides a 10-minute delay before second-stage heat is initiated. If the switch is toggled to the OFF position, it will provide a 15-minute delay before second-stage heat is initiated. This switch is only activated when the thermostat selector jumper is positioned for SINGLE-stage thermostat use.

Switch 4 -- Not used in G60UHV application.

Switches 5 and 6 -- Cooling Mode Blower Speed -- Switches 5 and 6 are used to select cooling blower motor speed. The unit is shipped from the factory with the dip switches positioned for high speed (4) indoor blower motor operation during the cooling mode. The table below provides the cooling mode blower speeds that will result from different switch settings. Refer to blower data tables at the front of this manual for corresponding cfm values.

**TABLE 8
Cooling Mode Blower Speeds**

Speed	Switch 5	Switch 6
1 - Low	On	On
2 - Medium Low	Off	On
3 - Medium High	On	Off
4 - High (Factory)	Off	Off

Switches 7 and 8 -- Blower Speed Adjustment -- Switches 7 and 8 are used to select blower speed adjustment settings. The unit is shipped from the factory with the dip switches positioned for NORMAL (no) adjustment. The dip switches may be positioned to adjust the blower speed by +10% or -10% to better suit the application. The table below provides blower speed adjustments that will result from different switch settings. Refer to blower data tables at the front of this manual for corresponding cfm values.

**TABLE 9
Blower Speed Adjustment**

Adjustment	Switch 7	Switch 8
+10% (approx.)	On	Off
NORMAL (Factory)	Off	Off
-10% (approx.)	Off	On

Switches 9 and 10 -- Cooling Mode Blower Speed Ramping -- Switches 9 and 10 are used to select cooling mode blower speed ramping options. Blower speed ramping may be used to enhance dehumidification performance. The switches are factory set at option A which has the greatest effect on blower motor performance. The table below provides the cooling mode blower speed ramping options that will result from different switch settings. The cooling mode blower speed ramping options are detailed on Page 14. See unit nameplate for manufacturing date.

**TABLE 10
Cooling Mode Blower Speed Ramping**

Ramping Option	Switch 9	Switch 10
A (Factory)	Off	Off
B	On	Off
C	Off	On
D*	On	On

*Only option for CCB1

G60UHV units manufactured before April 2003

Ramping Option A (Factory Selection)

- Motor runs at 50% for 1/2 minute.
- Motor then runs at 82% for approximately 7-1/2 minutes.
- If demand has not been satisfied after 7-1/2 minutes, motor runs at 100% until demand is satisfied.
- Once demand is met, motor runs at 50% for 1/2 minute.
- Motor ramps down to off.

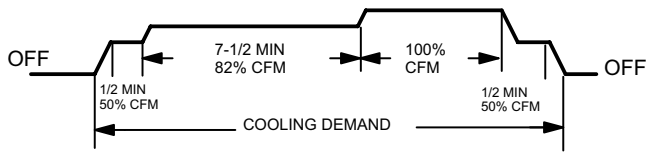

Ramping Option B

- Motor runs at 50% for 1/2 minute.
- Motor then runs at 82% for approximately 7-1/2 minutes.
- If demand has not been satisfied after 7-1/2 minutes, motor runs at 100% until demand is satisfied.
- Once demand is met, motor ramps down to off.

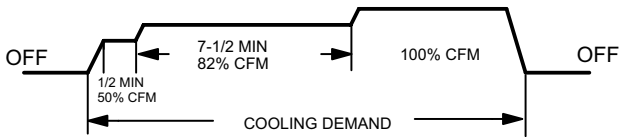

Ramping Option C

- Motor runs at 82% for approximately 7-1/2 minutes.
- If demand has not been satisfied after 7-1/2 minutes, the motor runs at 100% until demand is satisfied.
- Once demand is met, motor ramps down to off.

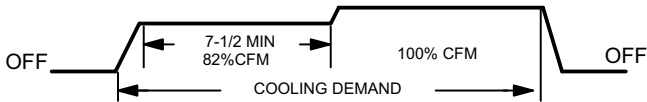

Ramping Option D

- Motor runs at 100% until demand is satisfied.
- Once demand is met, motor ramps down to off.

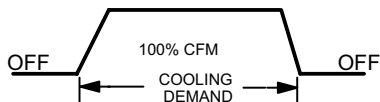

G60UHV units manufactured April 2003 and later

Ramping Option A (Factory Selection)

- Motor runs at 50% for 30 seconds.
- Motor then runs at 82% for approximately 7-1/2 minutes.
- If demand has not been satisfied after 7-1/2 minutes, motor runs at 100% until demand is satisfied.
- Once demand is met, motor runs at 50% for 30 seconds then ramps down to stop.

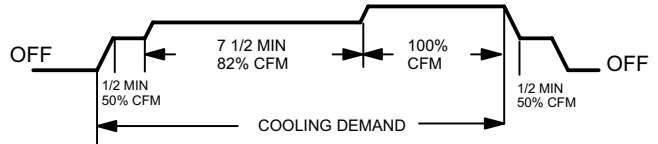

Ramping Option B

- Motor runs at 82% for approximately 7-1/2 minutes. If demand has not been satisfied after 7-1/2 minutes motor runs at 100% until demand is satisfied.
- Once demand is met, motor ramps down to stop.

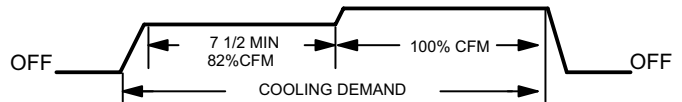

Ramping Option C

- Motor runs at 100% until demand is satisfied.
- Once demand is met, motor runs at 100% for 45* seconds then ramps down to stop.

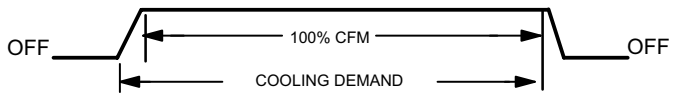

* G60UHV units date coded prior to 2-2006 will delay 60 seconds

Ramping Option D

- Motor runs at 100% until demand is satisfied.
- Once demand is met, motor ramps down to stop.

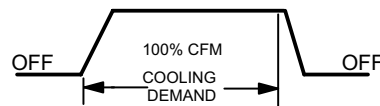

Switches 11 and 12 -- Heating Mode Blower Speed --

Switches 11 and 12 are used to select heating mode blower motor speed. The unit is shipped from the factory with the dip switches positioned for medium low (2) speed indoor blower motor operation during the heating mode. The table below provides the heating mode blower speeds that will result from different switch settings. Refer to blower data tables at the front of this manual for corresponding cfm values.

TABLE 11
Heating Mode Blower Speeds

Speed	Switch 11	Switch 12
1 - Low	On	On
2 - Medium Low (Factory)	Off	On
3 - Medium High	On	Off
4 - High	Off	Off

On-Board Jumper W914

On-board jumper W914, which connects terminals DS and R on the integrated control board, must be cut when the furnace is installed with either the Harmony II zone control board, the CCB1 EfficiencyPlus humidity control or Lennox SignatureStat™. Refer to table 21 for operation sequence in applications including a G60UHV, CCB1 and single-speed outdoor unit. Table 22 gives the operation sequence in applications with a two-speed outdoor unit. Refer to table

23 for operation sequence in applications including a G60UHV, SignatureStat and single-speed outdoor unit. Table 24 gives the operation sequence in applications with a two-speed outdoor unit.

On-Board Jumper W951

On-board jumper W951, which connects terminals R and O on the integrated control board, must be cut when the furnace is installed in applications which include a heat pump unit and the FM21 FuelMaster control board.

Factory-Installed Jumper Y1 to Y2

A factory-installed jumper from Y1 to Y2 terminals on the integrated control board terminal strip must be removed if two-stage cooling will be used.

Diagnostic LEDs (DS1 and DS2)

Two diagnostic LEDs are located on the two-stage, variable speed integrated control just to the left of the first bank of dip switches. These lights' flashes correspond with diagnostic codes detailed on in table 6.

Status LEDs (HEAT, HI/LO, ON/OFF and CFM)

The integrated control includes four LEDs which indicate operating status. The green ON/OFF LED is lit any time the blower is operating. The green CFM LED indicates the blower motor speed. Count the number of blinks between the two-second pauses to determine the CFM. Each blink represents approximately 100 CFM. The yellow HI/LO LED is lit when the W914 (DS to R) jumper **has not** been clipped for SignatureStat, CCB1 or Harmony operation. The yellow HEAT LED is lit when the indoor blower is operating at the HEATING speed.

⚠ WARNING

Shock hazard.

Disconnect power before servicing. Integrated Control Board is not field repairable. If control is inoperable, simply replace entire control.

Can cause injury or death. Unsafe operation will result if repair is attempted.

5. Integrated Control Board(A92) Board 100870

Beginning with G60UHV-7, units are equipped with the Lennox two-stage, variable speed integrated SureLight control board. The system consists of a ignition / blower control board (figure 5) with control pin designations in tables 12, 13 and 14 and ignitor (figure 12). The board and ignitor work in combination to ensure furnace ignition and ignitor durability. The SureLight integrated board controls all major furnace operations. The board features a red LED light, for furnace status and troubleshooting. The LED flashes in "X" + "Y" codes. For example using table 15 under "PRESSURE SWITCH CODES", if the red LED flashes 2 times, then off for 2 seconds then flashes 3 times, the low pressure switch is failed open. Two green LEDs show indoor blower status and CFM. See Page 20 for more detail. The board also has two 120 volt accessory terminals rated at (1) one amp each. In addition there is a 24 volt accessory terminal located on TB1.

Electronic Ignition

At the beginning of the heat cycle the SureLight control monitors the first stage and second stage combustion air inducer prove switch. The control will not begin the heating cycle if the first stage prove switch is closed (by-passed). Likewise the control will not begin the second stage heating cycle if the second stage prove switch is closed, and will remain in first stage heat. However, if the second stage prove switch closes during the first stage heat pre-purge, the control will allow second stage heat. Once the first stage prove switch is determined to be open, the combustion air inducer is energized on low (first stage) heat speed. When the differential in the prove switch is great enough, the prove switch closes and a 15-second pre-purge begins. If the switch is not proven within 2-1/2 minutes, the control goes into Watchguard-Pressure Switch mode for a 5-minute reset period.

After the 15-second pre-purge period, the SureLight ignitor warms up for 20 seconds after which the gas valve opens for a 4-second trial for ignition. The ignitor energizes during the trial until flame is sensed. If ignition is not proved during the 4-second period, the control will try four more times with an inter purge and warm-up time between trials of 35 seconds. After a total of five trials for ignition (including the initial trial), the control goes into Watchguard-Flame Failure mode. After a 60-minute reset period, the control will begin the ignition sequence again.

NOTE - Board 100870 provides a regulated 95 volts to the ignitor.

Two Stage Operation / Thermostat Selection Jumper

The control can be utilized in two modes: SINGLE-STAGE thermostat or TWO-STAGE thermostat. The thermostat selection is made using a dip switch (figure 4) and must be positioned for the particular application. The dip switch is factory set on "TWO" for use with a two-stage thermostat with two stage heat. Re-position dip switch to "SINGLE" for use with a single stage thermostat with two stage heat. While in the single-stage thermostat mode (*single* dip switch setting), the burners will always fire on first-stage heat. The combustion air inducer will operate on low speed and indoor blower will operate on low heat speed. After a factory default 10 minute recognition period, the unit will switch to second stage heat. While in the two-stage thermostat mode (*two* dip switch setting) the burners will fire on first-stage heat. The combustion air inducer will operate on low speed and indoor blower will operate on low heat speed. The unit will switch to second-stage heat on call from the indoor thermostat. If there is a simultaneous call for first and second stage heat, the unit will fire an first stage heat and switch to second stage heat after 30 seconds of operation. See Sequence of Operation flow charts in the back of this manual for more detail.

TWO-STAGE, VARIABLE SPEED INTEGRATED CONTROL BOARD

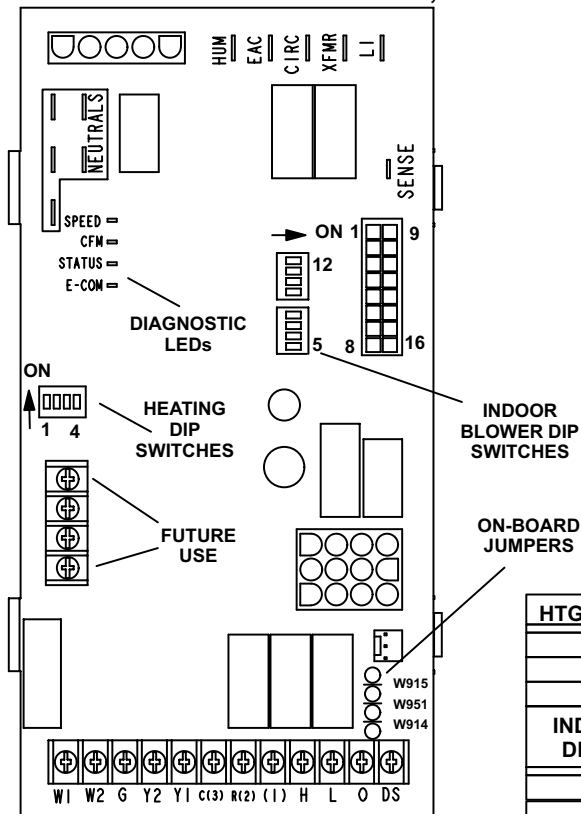

1/4" QUICK CONNECT TERMINALS

HUM = 120 VAC OUTPUT TO HUMIDIFIER
 XMFR = 120 VAC OUTPUT TO TRANSFORMER
 LI = 120 VAC INPUT TO CONTROL
 CIRC = 120 VAC OUTPUT TO CIRCULATING BLOWER
 EAC = 120 VAC OUTPUT TO ELECTRONIC AIR CLEANER
 NEUTRALS= 120 VAC NEUTRAL

THERMOSTAT CONNECTIONS (TB1)

DS= DEHUMIDIFICATION SIGNAL
 W2= HEAT DEMAND FROM 2ND STAGE T'STAT
 W1= HEAT DEMAND FROM 1ST STAGE T'STAT
 R= CLASS 2 VOLTAGE TO THERMOSTAT
 G= MANUAL FAN FROM T'STAT
 C= THERMOSTAT SIGNAL GROUND CONNECTED TO TRANSFORMER GROUND (TR) & CHASIS GROUND (GRD)
 Y1= THERMOSTAT 1st STAGE COOL SIGNAL
 Y2= THERMOSTAT 2nd STAGE COOL SIGNAL
 O= THERMOSTAT SIGNAL TO HEAT PUMP REVERSING VALVE
 H= 24V HUMIDIFIER OUTPUT
 L= LENNOX SYSTEM OPERATION MONITOR
 1= FUTURE USE

DIP SWITCH FUNCTIONS

HTG DIP SWITCH(ES)	FUNCTION
1	T'stat Heat Stages (single or two-stage)
2	Second Stage ON Delay (single-stage t'stat)
3 and 4	Heating Fan OFF Delay
INDOOR BLOWER DIP SWITCH(ES)	
5 and 6	Cooling Mode Blower Speed
7 and 8	Blower Speed Adjustment
9 and 10	Cooling Mode Blower Ramping Profile
11 and 12	Heating Mode Blower Speed

FIGURE 5

TABLE 12

PIN #	Function
1	Ignitor
2	Combustion Air Inducer High Speed
3	Combustion Air Inducer Low Speed
4	Combustion Air Inducer Neutral
5	Ignitor Neutral

TABLE 13

PIN #	Function
1	Gas Valve High Fire
2	Second Stage Prove Switch
3	Rollout In
4	Ground
5	24V Hot
6	Primary Limit In
7	Gas Valve Low Stage
8	Gas Valve Common
9	24V Neutral
10	Ground
11	Rollout Switch Out
12	1st Stage Prove Switch

TABLE 14

PIN #	Function
1	Ground
2	Low Heat Speed
3	Ground
4	"DELAY" Dip Switch Selection
5	"COOL" Dip Switch Selection
6	"Y1" Signal
7	"ADJUST" Dip Switch Selection
8	Ground
9	"0" From Thermostat
10	"DS" Output Signal
11	"HEAT" Dip Switch Selection
12	24 VAC
13	HIGH HEAT Speed
14	"Y2" Signal
15	"G"
16	CFM LED

TABLE 15

FLASH CODE (X + Y)	STATUS / ERROR DESCRIPTION
FLASH CODE DESCRIPTIONS	
Pulse	A 1/4 second flash followed by four seconds of off time.
Heartbeat	Constant 1/2 second bright and 1/2 second dim cycles.
X + Y	LED flashes X times at 2Hz, remains off for two seconds, flashes Y times at 2Hz, remains off for four seconds, then repeats.
Pulse	Power on - Standby.
Heartbeat	Normal operation - signaled when heating demand initiated at thermostat.
FLAME CODES	
1 + 2	Low flame current -- run mode.
1 + 3	Flame sensed out of sequence -- flame still present.
PRESSURE SWITCH CODES	
2 + 3	Low pressure switch failed open.
2 + 4	Low pressure switch failed closed.
2 + 5	High pressure switch failed open.
2 + 6	High pressure switch failed closed.
2 + 7	Low pressure switch opened during ignition trial or heating demand.
LIMIT CODE	
3 + 1	Limit switch open.
WATCHGUARD CODES	
4 + 1	Watchguard -- Exceeded maximum number of retries.
4 + 2	Watchguard -- Exceeded maximum number of retries or last retry was due to pressure switch opening.
4 + 3	Watchguard -- Exceeded maximum number of retries or last retry was due to flame failure.
4 + 5	Watchguard -- Limit remained open longer than three minutes.
4 + 6	Watchguard -- Flame sensed out of sequence; flame signal gone.
4 + 7	Ignitor circuit fault -- Failed ignitor or triggering circuitry.
4 + 8	Low line voltage.
HARD LOCKOUT CODES	
5 + 1	Hard lockout -- Rollout circuit open or previously opened.
5 + 2	Control failed self check, internal error (control will restart if error recovers).
5 + 3	No Earth ground (control will restart if error recovers).
5 + 4	Reversed line voltage polarity (control will restart if the error recovers).
5 + 6	Low secondary (24VAC) voltage.

Dip Switch Settings

Heating Operation DIP Switch Settings

Switch 1 -- Thermostat Selection -- This unit may be used with either a single-stage or two-stage thermostat. The thermostat selection is made using a DIP switch which must be properly positioned for the particular application. The DIP switch is factory-positioned for use with a two-stage thermostat. If a single-stage thermostat is to be used, the DIP switch must be repositioned.

- a - Select "OFF" for two-stage heating operation controlled by a two-stage heating thermostat (factory setting);
- b - Select "ON" for two-stage heating operation controlled by a single-stage heating thermostat. This setting provides a timed delay before second-stage heat is initiated.

Switch 2 -- Second Stage Delay (Used with Single-Stage Thermostat Only) -- This switch is used to determine the second stage on delay when a single-stage thermostat is being used. The switch is factory-set in the OFF position, which provides a 10-minute delay before second-stage heat is initiated. If the switch is toggled to the ON position, it will provide a 15-minute delay before second-stage heat is initiated. This switch is only activated when the thermostat selector jumper is positioned for SINGLE-stage thermostat use.

Switches 3 and 4 -- Blower-Off Delay -- The blower-on delay of 45 seconds is not adjustable. The blower-off delay (time that the blower operates after the heating demand has been satisfied) can be adjusted by moving switches 3 and 4 on the integrated control board. The unit is shipped from the factory with a blower-off delay of 90 seconds. The blower off delay affects comfort and is adjustable to satisfy individual applications. Adjust the blower off delay to achieve a supply air temperature between 90° and 110°F at the exact moment that the blower is de-energized. Longer off delay settings provide lower supply air temperatures; shorter settings provide higher supply air temperatures. Table 16 provides the blower off timings that will result from different switch settings.

TABLE 16
Blower Off Delay Switch Settings

Blower Off Delay (Seconds)	Switch 3	Switch 4
60	Off	On
90	Off	Off
120	On	Off
180	On	On

Indoor Blower Operation DIP Switch Settings

Switches 5 and 6 -- Cooling Mode Blower Speed -- Switches 5 and 6 are used to select cooling blower motor speed. The unit is shipped from the factory with the DIP switches positioned for high speed (4) indoor blower motor

operation during the cooling mode. The table below provides the cooling mode blower speeds that will result from different switch settings. Refer to blower tables at the front of this manual for corresponding cfm values.

TABLE 17
Cooling Mode Blower Speeds

Speed	Switch 5	Switch 6
1 - Low	On	On
2 - Medium Low	Off	On
3 - Medium High	On	Off
4 - High (Factory)	Off	Off

Switches 7 and 8 -- Blower Speed Adjustment -- Switches 7 and 8 are used to select blower speed adjustment settings. The unit is shipped from the factory with the DIP switches positioned for NORMAL (no) adjustment. The DIP switches may be positioned to adjust the blower speed by +10% or -10% to better suit the application. The table below provides blower speed adjustments that will result from different switch settings. Refer to blower tables at the front of this manual for corresponding cfm values.

TABLE 18
Blower Speed Adjustment

Adjustment	Switch 7	Switch 8
+10% (approx.)	On	Off
NORMAL (Factory)	Off	Off
-10% (approx.)	Off	On

Switches 9 and 10 -- Cooling Mode Blower Speed Ramping -- Switches 9 and 10 are used to select cooling mode blower speed ramping options. Blower speed ramping may be used to enhance dehumidification performance. The switches are factory set at option A which has the greatest effect on blower motor performance. Table 19 provides the cooling mode blower speed ramping options that will result from different switch settings. The cooling mode blower speed ramping options are detailed on Page 14 under "units manufactured April 2003 and later".

NOTE - The off portion of the selected ramp profile also applies during heat pump operation in dual fuel applications.

TABLE 19
Cooling Mode Blower Speed Ramping

Ramping Option	Switch 9	Switch 10
A (Factory)	Off	Off
B	On	Off
C	Off	On
D	On	On

Switches 11 and 12 -- Heating Mode Blower Speed -- Switches 11 and 12 are used to select heating mode blower motor speed. The unit is shipped from the factory with the dip switches positioned for medium low (2) speed indoor blower motor operation during the heating mode. The table below provides the heating mode blower speeds that will result from different switch settings. Refer to blower tables at the front of this manual for corresponding cfm values.

TABLE 20
Heating Mode Blower Speeds

Speed	Switch 11	Switch 12
1 - Low	On	On
2 - Medium Low (Factory)	Off	On
3 - Medium High	On	Off
4 - High	Off	Off

On-Board Jumper W914

On-board jumper W914, which connects terminals DS and R on the integrated control board, must be cut when the furnace is installed with either the Harmony III zone control board or a thermostat which features humidity control. If the jumper is left intact the PWM signal from the HARMONY III control will be blocked and also lead to control damage. Refer to table 21 (CCB1) or 23 (SignatureStat™) for operation sequence in applications including G60UHV, a thermostat which features humidity control and a single-speed outdoor unit. Table 22 (CCB1) and table 24 (SignatureStata) gives the operation sequence in applications with a two-speed outdoor unit.

On-Board Jumper W951

On-board jumper W951, which connects terminals R and O on the integrated control board, must be cut when the furnace is installed in applications which include a heat pump unit and a thermostat which features dual fuel use. If the jumper is left intact, terminal "O" will remain energized eliminating the HEAT MODE in the heat pump.

On-Board Jumper W915

On-board jumper W915, which connects terminals Y1 and Y2 on the integrated control board, must be cut if two-stage cooling will be used. If the jumper is not cut the outdoor unit will operate in second-stage cooling only.

Status LEDs (SPEED, CFM, E-COM)

The green SPEED LED indicates circulating blower speed in response to the DS signal. The LED is lit during normal blower operation and is off during a dehumidification demand. In Harmony III applications, the brightness of the LED indicates the requested blower speed.

The green CFM LED indicates the blower air flow. Count the number of blinks between the two-second pauses to determine the CFM. Each blink represents approximately 100 CFM.

The green E-COM LED indicates that the control is receiving and processing of commands and inputs. The LED may flash rapidly or may display a single flash, depending upon the activity.

TABLE 21
G60UHV, CCB1 and Single-Speed Outdoor Unit

OPERATING MODE System Condition	SYSTEM DEMAND		SYSTEM RESPONSE	
	Thermostat Demand	*Relative Humidity (EfficiencyPlus Lights)	Blower CFM (COOL)	Comments
Normal operation	Y1	No demand. Humidity level is acceptable	COOL	Compressor demand and indoor blower speed controlled by thermostat demand.
*Call for humidity removal during cooling demand	Y1	Humidity level rises above setpoint. Demand initiated.	60%/65% of COOL	Call for dehumidification initiated by CCB1 control. Indoor blower speed reduced by CCB1 control.
Dehumidification demand satisfied during cooling demand.	Y1	Humidity level falls below setpoint. No demand	COOL	When humidity demand is satisfied, blower speed immediately increases to the COOL CFM to hasten the end of the cycle.
Call for cooling after call for humidity removal.	None	Humidity level above setpoint. Demand initiated.	Off	Dehumidification mode begins when relative humidity is greater than setpoint.
	Y1	Humidity level above setpoint. Demand initiated.	60%/65% of COOL	
Humidity demand satisfied between thermostat demands (unit off cycle).	None	Over setpoint (1 or more)	Off	While unit is not operating (no thermostat demand), slide switch is moved down and back up. Blower operates at COOL CFM.
	Y1	Change to acceptable	COOL	

NOTE - When changing unit mode of operation from cooling to heating, indicating lights that are on will stay on until the first thermostat heating demand.

** Reduced blower speed is 65% of COOL for the -36A and -36B units; 60% of COOL for -60C and -60D series units.*

**TABLE 22
G60UHV, CCB1 and Two-Speed Outdoor Unit**

OPERATING MODE System Condition	SYSTEM DEMAND		SYSTEM RESPONSE		
	Thermostat Demand	*Relative Humidity (EfficiencyPlus Lights)	****Compressor Speed	Blower CFM (COOL)	Comments
Normal operation	Y1	No demand. Acceptable	Low	**42%/46%/49% of HIGH COOL	Compressor demand and indoor blower speed controlled by thermostat demand
	Y2	No demand. Acceptable	High	HIGH COOL	
Call for humidity removal during 1st-stage cooling demand	Y1	No demand. Acceptable	Low	**42%/46%/49% of HIGH COOL	Dehumidification mode does not begin until after initial thermostat demand is satisfied and new cooling demand is initiated.
	Y1	Humidity level rises slightly (1) above setpoint. Demand initiated.	Low	**42%/46%/49% of HIGH COOL	
	Demand satisfied	Humidity level remains slightly (1) above setpoint. Demand continues.	Off	Off	
	Y1	Humidity level remains slightly (1) above setpoint. Demand continues.	High	***65%/60% of HIGH COOL	
Significant increase in humidity during thermostat cooling demand.	Y1	No demand. Acceptable	Low	**42%/46%/49% of HIGH COOL	If humidity rises significantly above setpoint, or if slide switch is moved significantly, unit will immediately go into dehumidification mode (in presence of thermostat demand).
	Y1	Humidity level rises significantly (2 or more) above setpoint. Demand initiated.	High	***65%/60% of HIGH COOL	
Humidity demand satisfied during thermostat demand.	Y1	Humidity level above setpoint.	High	***65%/60% of HIGH COOL	When humidity demand is satisfied, blower immediately shifts to the COOL CFM in order to hasten the end of the cycle. Unit can only shift out of high speed compressor operation at beginning of next cycle.
	Y1	Humidity level falls below setpoint. No demand.	High	HIGH COOL	
	None	No demand. Acceptable	Off	Off	
	Y1	No demand. Acceptable	Low	**42%/46%/49% of HIGH COOL	
Call for humidity removal during 2nd stage thermostat demand	Y2	No demand. Acceptable	High	HIGH COOL	Blower immediately changes speed in response to thermostat demand.
	Y2	Humidity level rises slightly (1) above setpoint. Demand initiated.	High	***65%/60% of HIGH COOL	
	Y2	No demand. Acceptable	High	HIGH COOL	
*Call for 1st stage cooling after call for humidity removal.	None	Humidity level is slightly (1) above setpoint.	Off	Off	Dehumidification mode (high speed compressor) begins with next thermostat demand after initial demand is satisfied.
	Y1	Humidity level is slightly (1) above setpoint.	Low	**42%/46%/49% of HIGH COOL	
Call for 2nd stage cooling after call for humidity removal	None	Humidity level is slightly (1) above setpoint.	Off	Off	Reduced blower speed (dehumidification speed) begins immediately with thermostat demand
	Y2	Humidity level is slightly (1) above setpoint.	High	***65%/60% of HIGH COOL	
Call for cooling after significant increase in humidity	None	Humidity level is significantly above setpoint (2 or more).	Off	Off	If humidity increases significantly over setpoint, or if slide switch is moved, unit immediately goes into dehumidification mode (in presence of thermostat demand).
	Y1 or Y2	Humidity level is significantly above setpoint (2 or more).	High	***65%/60% of HIGH COOL	
Humidity demand satisfied between thermostat demands (unit off cycle).	None	Humidity level is slightly (1) above setpoint.	Off	Off	While unit is not operating (no thermostat demand), slide switch is moved down and back up. Blower and compressor operate at high speed until next thermostat demand.
	Y1 or Y2	Humidity level falls below setpoint. No demand.	High	HIGH COOL	

NOTE - When changing unit mode of operation from cooling to heating, indicating lights that are on will stay on until the first thermostat heating demand.

**IMPORTANT - If power to unit is turned on with CCB1 calling for humidity removal, outdoor unit may be locked into high speed indefinitely. To reset, move humidity slide switch all the way down then back up to desired setpoint (with unit running)*

*** Reduced blower speed for ALL model units manufactured September 2002 and later is 49% of HIGH COOL. (Earlier date code: -42% of HIGH COOL for -36A and -36B units; 46% of HIGH COOL for -60C and -60D series units)*

**** Reduced blower speed is 65% of HIGH COOL for -36A and -36B units; 60% of HIGH COOL for -60C and -60D series units.*

*****If the two-speed control on a two-speed outdoor unit is set for LATCH 2 (15 minutes) or LATCH 3 (30 minutes), the compressor will latch into high speed after a Y1 demand has occurred for that period of time.*

TABLE 23
G60UHV, SignatureStat™ and SINGLE STAGE OUTDOOR UNIT

OPERATING SEQUENCE		SYSTEM DEMAND							SYSTEM RESPONSE			
System Condition	Step	Thermostat Demand					Relative Humidity		Compressor	Blower CFM (COOL)	Comments	
		Y1		O	G	W 1	Status	D				
<i>NO CALL FOR DEHUMIDIFICATION</i>												
Normal Operation	1	On		On	On			Acceptable	24 VAC	High	100%	Compressor and indoor blower follow thermostat demand
<i>BASIC MODE (only active on a Y1 thermostat demand)</i>												
Normal Operation	1	On		On	On			Acceptable	24 VAC	High	100%	SignatureStat energizes Y1 and de-energizes D on a call for de-humidification
Dehumidification Call	2	On	On	On	On			Demand	0 VAC	High	60%, 65%, 70%*	
<i>PRECISION MODE (operates independent of a Y1 thermostat demand)</i>												
Normal Operation	1	On		On	On			Acceptable	24 VAC	High	100%	Dehumidification mode begins when humidity is greater than set point
Dehumidification call	2	On		On	On			Demand	0 VAC	High	60%, 65%, 70%*	
Dehumidification call ONLY	1	On		On	On			Demand	0 VAC	High	60%, 65%, 70%*	SignatureStat will try to maintain room humidity setpoint by allowing the room space to maintain a cooler room thermostat setpoint**
	Jumpers at indoor unit with a single stage outdoor unit With Condensing unit - Cut W914 (R to DS) on SureLight board With Heat Pump - Cut W914 (R to DS) & W951 (R to O) on SureLight board											

Dave Lennox SignatureStat to use for this application - 51M26 1 heat / 1 cool or 51M28 - 2 heat / 2 cool for heat pumps

**Dehumidification blower speed is 65% of COOL speed for 36A & 36B units and 60% COOL speed for 60C & 60D units manufactured before 09-2002. Dehumidification blower speed is 70% of COOL speed for all units manufactured 09-2002 and later.*

***In Precision mode, SignatureStats built before 10-2003 will maintain room temperature up to 3°F(1.8°C) cooler than room setting. Signature Stats built 10-2003 and later will maintain room temperature up to 2 °F (1.2°C) cooler than room setting.*

TABLE 24
G60UHV, SignatureStat™ and TWO STAGE OUTDOOR UNIT

OPERATING SEQUENCE		SYSTEM DEMAND							SYSTEM RESPONSE			
System Condition	Step	Thermostat Demand					Relative Humidity		Compressor	Blower CFM (COOL)	Comments	
		Y1	Y2	O	G	W 1	W 2	Status				D
NO CALL FOR DEHUMIDIFICATION												
Normal Operation - Y1	1	On		On	On			Acceptable	24 VAC	Low	60%, 65% 70%*	Compressor and indoor blower follow thermostat demand
Normal Operation - Y2	2	On	On	On	On			Acceptable	24 VAC	High	100%	
ROOM THERMOSTAT CALLS FOR FIRST STAGE COOLING												
<i>BASIC MODE (only active on a Y1 thermostat demand)</i>												
Normal Operation	1	On		On	On			Acceptable	24 VAC	Low	60%, 65% 70%*	SignatureStat energizes Y2 and de-energizes D on a call for de-humidification
Dehumidification Call	2	On	On	On	On			Demand	0 VAC	High	60%, 65% 70%**	
<i>PRECISION MODE (operates independent of a Y1 thermostat demand)</i>												
Normal Operation	1	On		On	On			Acceptable	24 VAC	Low	60% 65% 70%*	Dehumidification mode begins when humidity is greater than set point
Dehumidification call	2	On	On	On	On			Demand	0 VAC	High	60% 65% 70%**	
Dehumidification call ONLY	1	On	On	On	On			Demand	0 VAC	High	60% 65% 70%**	SignatureStat will try to maintain room humidity setpoint by allowing the room space to maintain a cooler room thermostat setpoint***
ROOM THERMOSTAT CALLS FOR FIRST AND SECOND STAGE COOLING												
<i>BASIC MODE (only active on a Y1 thermostat demand)</i>												
Normal Operation	1	On	On	On	On			Acceptable	24 VAC	High	100%	SignatureStat energizes Y2 and de-energizes D on a call for de-humidification
Dehumidification Call	2	On	On	On	On			Demand	0 VAC	High	60% 65% 70%**	
<i>PRECISION MODE (operates independent of a Y1 thermostat demand)</i>												
Normal Operation	1	On		On	On			Acceptable	24 VAC	Low	60% 65% 70%*	Dehumidification mode begins when humidity is greater than set point
Dehumidification call	2	On	On	On	On			Demand	0 VAC	High	60% 65% 70%**	
Dehumidification call ONLY	1	On	On	On	On			Demand	0 VAC	High	60% 65% 70%**	SignatureStat will try to maintain room humidity setpoint by allowing the room space to maintain a cooler room thermostat setpoint***
Jumpers at indoor unit with a two stage outdoor unit RCut factory jumper from Y1 to Y2 or cut W915 (Y1 to Y2) With Condensing unit - Cut W914 (R to DS) on SureLight board With Heat Pump - Cut W914 (R to DS) & W951 (R to O) on SureLight board												

Dave Lennox SignatureStat to use for this application - 51M27 2 heat / 2 cool or 51M28 - 2 heat / 2 cool for heat pumps

*Normal operation first stage cooling blower speed is as follows for units built before 09-2002: 65% of COOL for 36A, 36B, 60% COOL for 60C, 60D units. ALL units built 09-2002 and later first stage blower speed is 70% COOL speed.

**Dehumidification blower speed is as follows for units built before 09-2002: 65% of COOL for 36A, 36B 60% of COOL for 60C, 60D. ALL units built 09-2002 and later, reduced blower speed is 70% of COOL.

***In Precision mode, Signature Stats built before 10-2003 will maintain room temperature up to 3°F(1.8°C) cooler than room setting. Signature Stats built 10-2003 and later will maintain room temperature up to 2 °F (1.2°C) cooler than room setting.

6. Blower Motor Figure 6

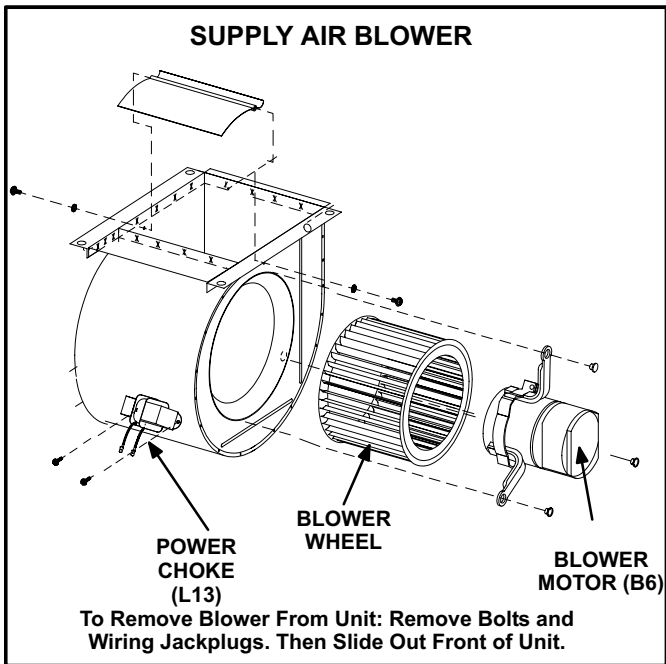

FIGURE 6

Blower Motor (B3)

G60UHV units use a three-phase, electronically controlled D.C. brushless motor (controller converts single phase a.c. to three phase D.C.), with a permanent-magnet-type rotor (figure 7). Because this motor has a permanent magnet rotor it does not need brushes like conventional D.C. motors. Internal components are shown in figure 8. The stator windings are split into three poles which are electrically connected to the controller. This arrangement allows motor windings to turn on and off in sequence by the controller.

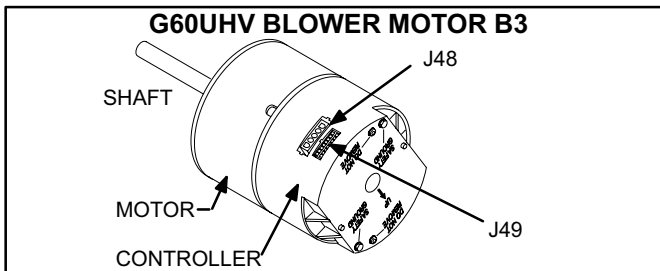

FIGURE 7

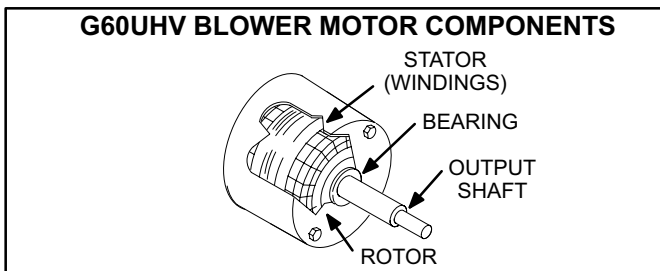

FIGURE 8

A solid-state controller is permanently attached to the motor. The controller is primarily an A.C. to D.C. converter. Converted D.C. power is used to drive the motor. The controller contains a microprocessor which monitors varying conditions inside the motor (such as motor workload).

The controller uses sensing devices to sense what position the rotor is in at any given time. By sensing the position of the rotor and then switching the motor windings on and off in sequence, the rotor shaft turns the blower.

All G60UHV blower motors use single phase power. An external run capacitor is not used. The motor uses permanently lubricated ball-type bearings.

Internal Operation

Each time the controller switches a stator winding (figure 8) on and off, it is called a "pulse." The length of time each pulse stays on is called the "pulse width." By varying the pulse width (figure 10), the controller varies motor speed (called "pulse-width modulation"). This allows for precise control of motor speed and allows the motor to compensate for varying load conditions as sensed by the controller. In this case, the controller monitors the static workload on the motor and varies motor rpm in order to maintain constant airflow (cfm).

The motor controller is driven by the Two-stage Variable Speed Integrated control board. The board receives its demand (PWM signal or fixed 24 VAC or VDC signal) from optional controls such as the Harmony zone control system, Efficiency Plus Humidity Control (CCB1) or a conventional thermostat.

Motor rpm is continually adjusted internally to maintain constant static pressure against the blower wheel. The controller monitors the static work load on the motor and motor amp-draw to determine the amount of rpm adjustment. Blower rpm may be adjusted any amount in order to maintain a constant cfm as shown in Blower Ratings Tables. The cfm remains relatively stable over a broad range of static pressure. Since the blower constantly adjusts rpm to maintain a specified cfm, motor rpm is not rated. Hence, the terms "cool speed", "heat speed" or "speed tap" in this manual, on the unit wiring diagram and on blower B3, refer to blower cfm regardless of motor rpm.

When Harmony is used, speed taps are overridden and a PWM signal generated by the Harmony controller continuously varies motor speed based upon zone demands.

Initial Power Up

When line voltage is applied to B3, there will be a large inrush of power lasting less than 1/4 second. This inrush charges a bank of DC filter capacitors inside the controller. If the disconnect switch is bounced when the disconnect is closed, the disconnect contacts may become welded. Try not to bounce the disconnect switch when applying power to the unit.

Motor Start-Up

When B3 begins start-up, the motor gently vibrates back and forth for a moment. This is normal. During this time the electronic controller is determining the exact position of the rotor. Once the motor begins turning, the controller slowly eases the motor up to speed (this is called "soft-start"). The motor may take as long as 10-15 seconds to reach full speed. If the motor does not reach 200rpm within 13 seconds, the motor shuts down. Then the motor will immediately attempt a re-start. The shutdown feature provides protection in case of a frozen bearing or blocked blower wheel. The motor may attempt to start eight times. If the motor does not start after the eighth try, the controller locks out. Reset controller by momentarily turning off power to unit.

The DC filter capacitors inside the controller are connected electrically to the speed tap wires. The capacitors take approximately 5 minutes to discharge when the disconnect is opened. For this reason it is necessary to wait at least 5 minutes after turning off power to the unit before attempting to change speed taps.

⚠ DANGER

Disconnect power from unit and wait at least five minutes to allow capacitors to discharge before attempting to adjust motor speed tap settings. Failure to wait may cause personal injury or death.

External Operation (Speed Tap Priority)

Figure 9 shows the two quick-connect jacks (J48 and J49) which connect the motor to the G60UHV. Jack J48 is the power plug and jack J49 connects the unit controls to the motor.

Line voltage must be applied to J48 pin 5 in order for the motor to operate. When using 120VAC pins 1 and 2 must be jumpered. When control voltage is applied to J49 pin 3 and 15, the motor is energized on the continuous fan mode.

When voltage is applied to J49 pin 2 in addition to pin 3 and 15 (first stage heating), the blower is energized on the low speed heating tap. When voltage is applied to J49 pin 13 in addition to pin 3 and 15 (second stage heating), the blower

is energized on the high speed heating tap. The motor assigns priority to J49 pin 2 so that if a call for cooling and a call for heating are concurrent, heating call overrides and the blower operates on high speed heating tap.

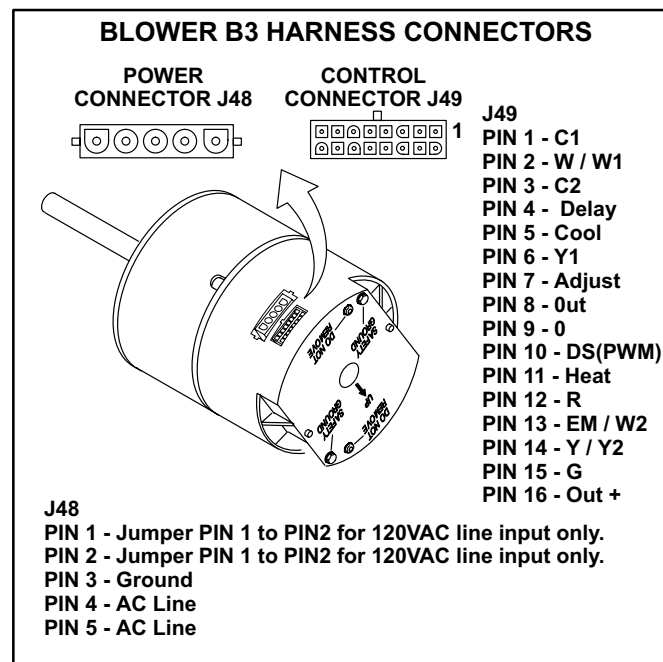

FIGURE 9

Power Choke (L13)

A choke coil is used on G60UHV 5 ton 1 hp units. The choke is located on the blower housing and is used to suppress transient current spikes.

Precautions



If the G60UHV or its electronically controlled blower motor is improperly or inadequately grounded, it may cause television interference (commonly known as RFI or radio frequency interference).

This interference is caused by internal switching frequencies of the motor controller. TV interference may show up as small specks or lines which randomly appear on the TV screen accompanied by pops or clicks in the sound. Before attempting any service, make sure the indoor unit is causing the interference. To check, disconnect power to indoor unit then check TV for continued signs of interference.

TV interference may be stopped by making sure the motor is solidly grounded to the cabinet (metal to metal) and by making sure the cabinet is solidly grounded. If TV interference persists, make sure the television (and all affected RF appliances) are moved away from the G60UHV. Also make sure affected appliances are connected to a separate electrical circuit.

MOTOR SPEED CONTROL WITH D.C. PULSE-WIDTH MODULATION

Motor speed is determined by the size of the electrical pulse sent to the motor windings. The longer the pulse, the faster the motor.

OUTPUT FROM CONTROLLER TO MOTOR WINDINGS	
WINDINGS TURNED OFF	WINDINGS TURNED ON
	 ON PULSE  OFF PULSE

The frequency of the pulses to the windings is 20KHz.
DO NOT ATTEMPT TO MEASURE THESE VOLTAGES.

LOW SPEED HEAT/COOL (output from controller to motor windings)

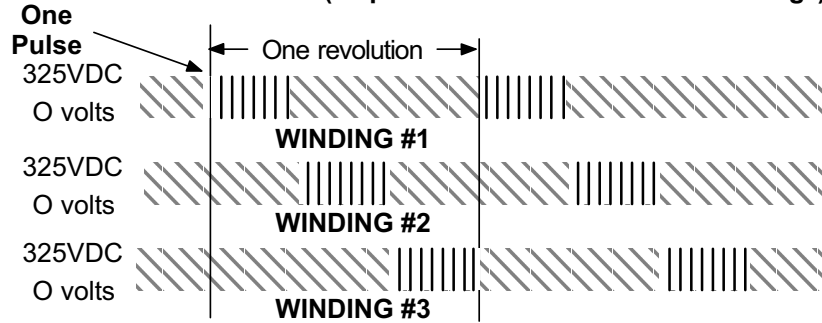

HIGH SPEED HEAT (output from controller to motor windings)

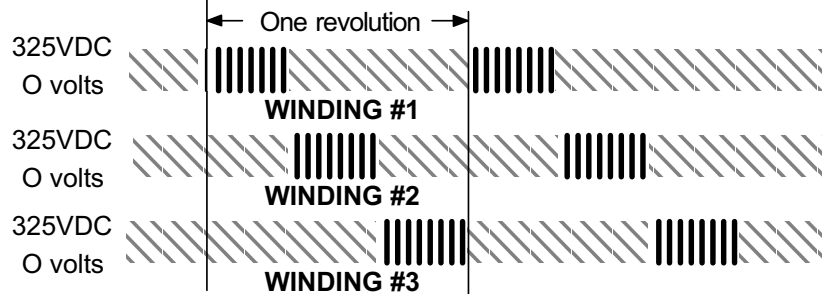

HIGH SPEED COOL (output from controller to motor windings)

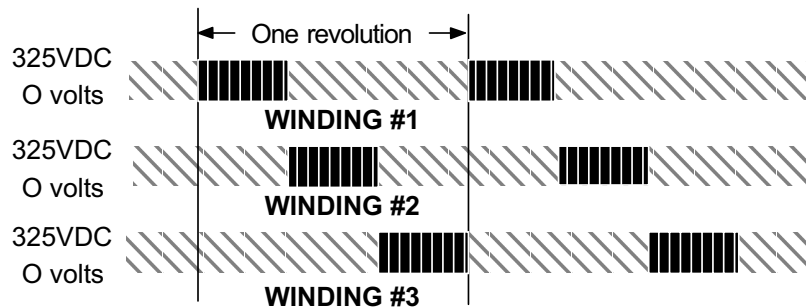

FIGURE 10

7. Ignitor

The SureLight ignitor is made of durable silicon nitride. Ignitor longevity is enhanced by controlling voltage to the ignitor. Boards 18M49 and 49M59 find the lowest ignitor temperature which will successfully light the burner, thus increasing the life of the ignitor. Due to this feature of the board, voltage cannot be measured so ignitor must be ohmed. Board 100870 provides a regulated 95 volts to the ignitor for consistent ignition and long ignitor life. Ohm value for ignitors with SureLight boards 18M99 and 49M59 should be 10.9 to 19.7. Ohm value for ignitors with board 100870 should be 25 to 47. See figure 11 and 12 (make note of control board used) for ignitor location. Ignitors are not interchangeable between boards.

NOTE - The G60UHV(X) furnace contains electronic components that are polarity sensitive. Make sure that the furnace is wired correctly and is properly grounded.

8. Flame Sensor

A flame sensor is located on the left side of the burner support. See figure 13 and 14 (make note of control board used). The sensor is mounted on the flame rollout plate and the tip protrudes into the flame envelope of the left-most burner. The sensor can be removed for service without removing any part of the burners. During operation, flame is sensed by current passed through the flame and sensing electrode. The SureLight control allows the gas valve to remain open as long as flame signal is sensed.

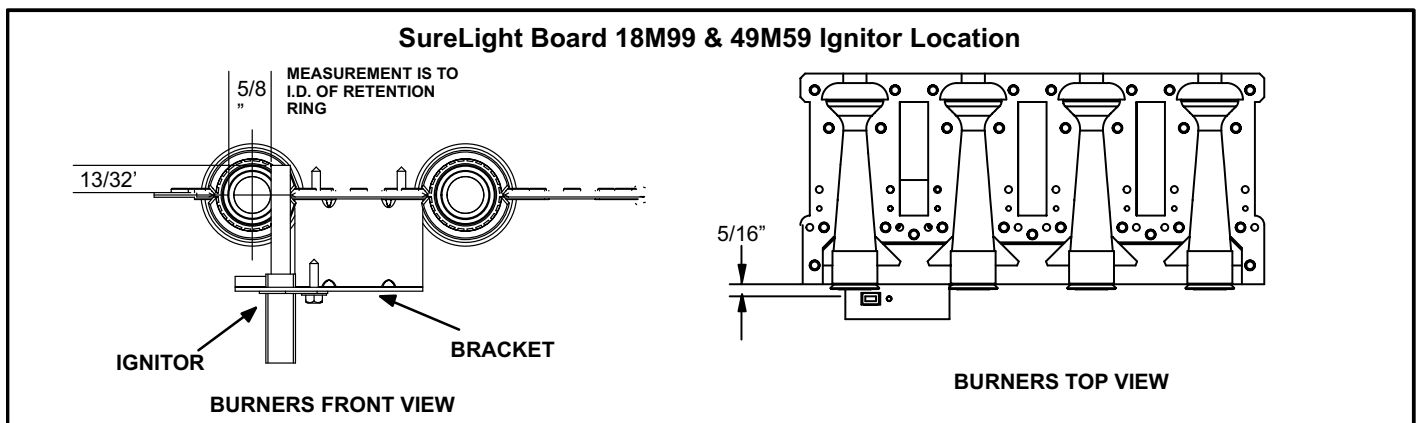

FIGURE 11

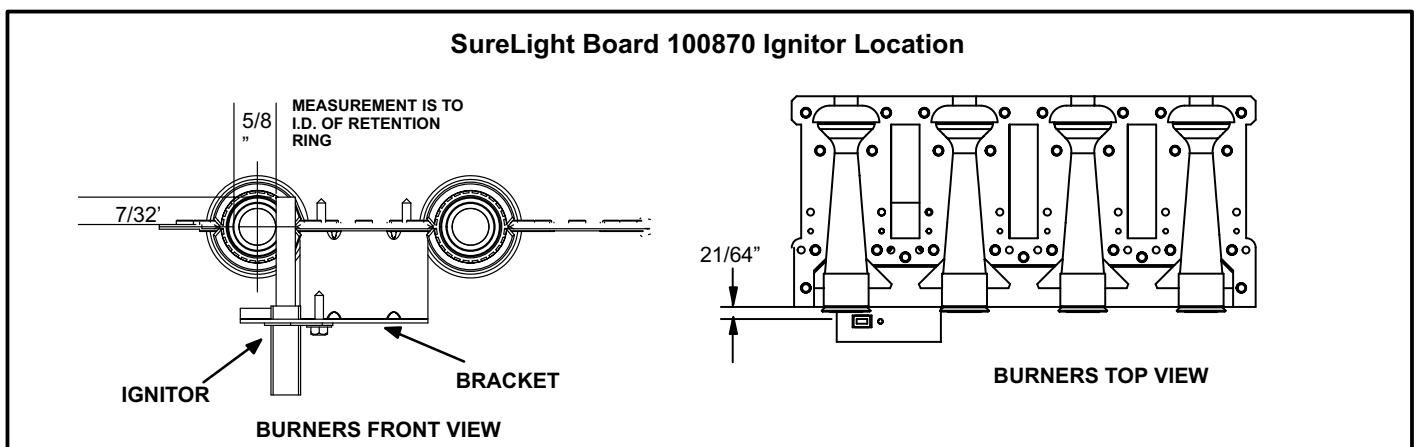

FIGURE 12

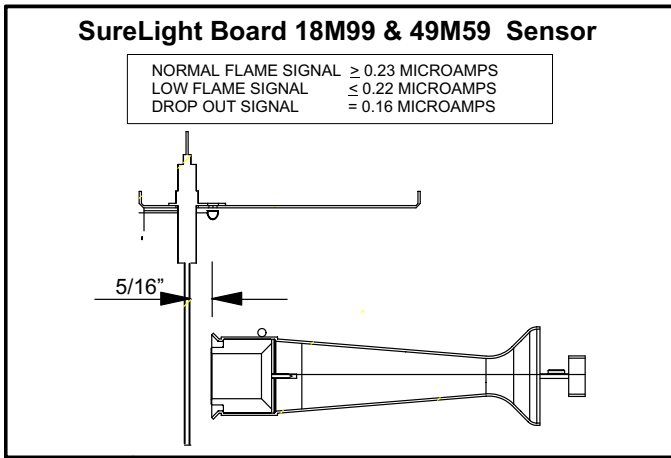

FIGURE 13

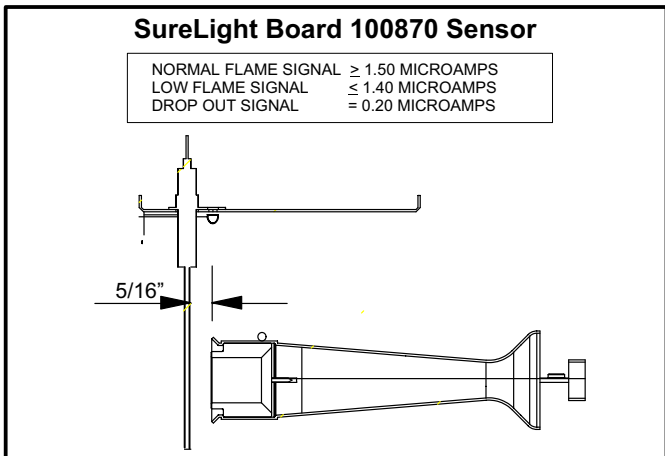

FIGURE 14

9. Combustion Air Inducer (B6)

All G60UHV(X) units use a two-stage combustion air inducer to move air through the burners and heat exchanger during heating operation. The blower uses a 120VAC motor. The motor operates during all heating operation and is controlled by furnace / blower control A92. The inducer also operates for 15 seconds before burner ignition (pre-purge) and for 5 seconds after the gas valve closes (post-purge). The inducer operates on low speed during first-stage heat, then switches to high speed for second stage heat.

A proving switch connected to the combustion air inducer orifice plate is used to prove inducer operation. The combustion air inducer orifice will be different for each model. See table 25 for orifice sizes. The switch monitors air pressure in the inducer housing. During normal operation, the pressure in the housing is negative. If pressure becomes less negative (signifying an obstruction) the proving switch opens. When the proving switch opens, the furnace control (A92) immediately closes the gas valve to prevent burner operation.

TABLE 25

G60UHV(X) Unit	C.A.I. Orifice Size
-070	1.5"
-090	1.75"
-110	2.0"
-135	2.25"

Horizontal Applications

The G60UHV(X) furnace can be installed in horizontal applications.

The combustion air inducer may be rotated clockwise or counterclockwise by 90° to allow for vertical vent discharge in a horizontal application. Remove the four mounting screws, rotate the assembly (assembly consists of orifice plate, proving switch, gasket and combustion air inducer), then reinstall the mounting screws. See figure 15. Use the provided wire tie to bundle the pressure switch wires with the inducer motor power leads. **Route the wires away from moving parts and the heat of the inducer motor to prevent damage to the wires.** Use sheet metal shears to remove the cut out from the side of the cabinet. See figure 16. Use the two provided sheet metal screws to install the cut out on the top cap to cover the original flue outlet opening.

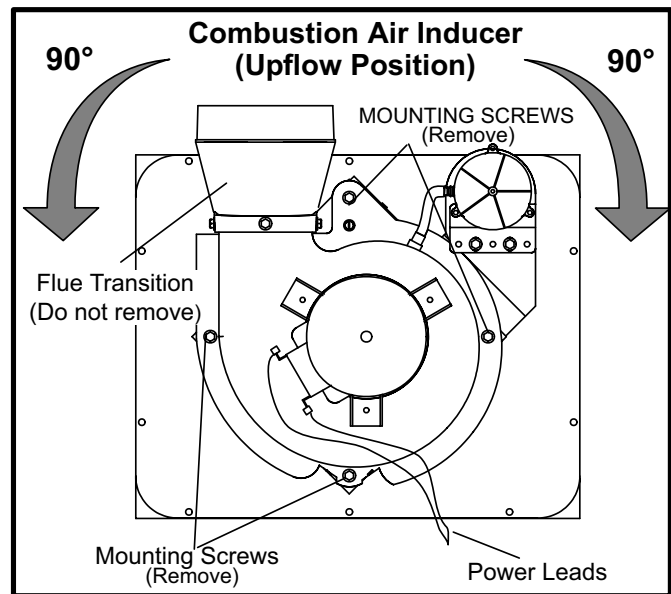

FIGURE 15

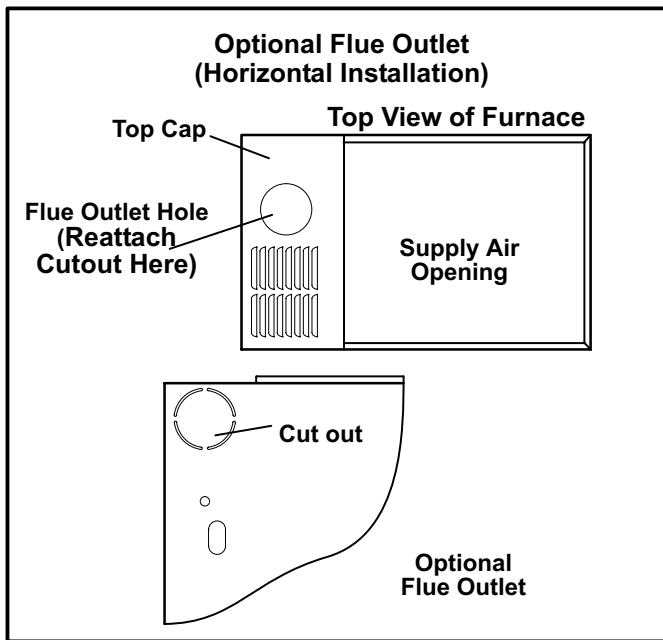

FIGURE 16

10. Flame Rollout Switches (S47)

Flame rollout switch is a high temperature limit located on top of the burner box. Each furnace is equipped with two identical switches. One switch is located over the leftmost burner and the other switch is located over the rightmost burner. The limit is a N.C. SPST manual-reset limit connected in series with the primary limit S10. When S47 senses rollout, the circuit breaks and the ignition control immediately stops ignition and closes the gas valve.

If unit is running and flame rollout is detected, the gas valve will close and ignition control will be disabled. Rollout can be caused by a blocked heat exchanger, flue or lack of combustion air. The switch is factory set to trip (open) at 210°F and cannot be adjusted. The switch can be manually reset. To manually reset a tripped switch, push the reset button located on the control.

11. Primary Limit Control (S10)

The primary limit (S10) on G60UHV(X) units is located in the heating vestibule panel. When excess heat is sensed in the heat exchanger, the limit will open. If the limit is open, the furnace control energizes the supply air blower and closes the gas valve. The limit automatically resets when unit temperature returns to normal. The switch must reset within three minutes or the SureLight board will go into Watch guard for one hour. The switch is factory set and cannot be adjusted. The switch may have a different set point for each unit model number. If limit switch must be replaced, call Lennox Repair Parts for correct length and set point.

12. Secondary Limit Controls (S21)

The secondary limit (S21) on G60UHV(X) units is located in the blower compartment on the back side of the blower housing. See figure 1. Blower speed chart on the wiring diagram show secondary limit quantities per unit. When excess heat is sensed in the blower compartment, the limit will open. If the limit is open, the furnace control energizes the supply air blower and closes the gas valve. The limit automatically resets when unit temperature returns to normal. G60UHV-1 and -2 units use a surface type limit factory set to open at 125°F. G60UHV-3 units and later use an airstream type limit factory set to open at 135°. The secondary limit cannot be adjusted.

13. Gas Valve

The G60UHV(X) uses a two-stage gas valve manufactured by White Rodgers or Honeywell (figures 17 and 18). The valve is internally redundant to assure safety shut-off. If the gas valve must be replaced, the same type valve must be used.

24VAC terminals and gas control knob or switch are located on the valve. All terminals on the gas valve are connected to wires from the electronic ignition control. 24V applied to the terminals energizes the valve.

Inlet and outlet pressure taps are located on the valve. A regulator adjustment screw is located on the valve.

LPG change over kits (Honeywell valve only) are available from Lennox. Kits include burner orifices and a gas valve regulator conversion kit.

14. Combustion Air Inducer Prove Switch (S18)

G60UHV(X) series units are equipped with a dual combustion air proving switch (first and second stage) located on the combustion air inducer orifice bracket. The switch is connected to the combustion air inducer housing by means of a flexible silicone hose. It monitors negative air pressure in the combustion air inducer housing.

The switches are a single-pole single-throw proving switch electrically connected to the furnace control. The purpose of the switch is to prevent burner operation if the combustion air inducer is not operating or if the flue becomes obstructed.

On heat demand (first or second stage) the switch senses that the combustion air inducer is operating. It closes a circuit to the furnace control when pressure inside the combustion air inducer decreases to a certain set point.

Set points vary depending on unit size. See tables 26, 27 and 28. The pressure sensed by the switch is negative relative to atmospheric pressure. If the flue becomes obstructed during operation, the switch senses a loss of negative pressure (pressure becomes more equal with atmospheric pressure) and opens the circuit to the furnace control and gas valve. A bleed port on the switch allows relatively dry air in the vestibule to purge switch tubing, to prevent condensate build up.

The switch is factory set and is not field adjustable. It is a safety shut-down control in the furnace and must not be by-passed for any reason. If switch is closed or by-passed, the control will not initiate ignition at start up.

TABLE 26
0' to 4500'

G60UHV(X) Unit	Set Point High Heat	Set Point Low Heat
-070	0.40"	0.20"
-090	0.45"	0.20"
-110	0.50"	0.20"
-135	0.50"	0.20"

TABLE 27*
4501' to 7500'

G60UHV(X) Unit	Set Point High Heat	Set Point Low Heat
-070	0.40"	0.20"
-090	0.40"	0.20"
-110	0.45"	0.20"
-135	0.45"	0.20"

**Unit requires conversion kit at this altitude. See High Altitude table.*

TABLE 28*
7501' to 10,000'

G60UHV(X) Unit	Set Point High Heat	Set Point Low Heat
-070	0.35"	0.20"
-090	0.35"	0.20"
-110	0.40"	0.20"
-135	0.40"	0.20"

**Unit requires conversion kit at this altitude. See High Altitude table.*

II-PLACEMENT AND INSTALLATION

Make sure unit is installed in accordance with installation instructions and applicable codes.

III-START-UP

A-Preliminary and Seasonal Checks

- 1 - Inspect electrical wiring, both field and factory installed for loose connections. Tighten as required.
- 2 - Check voltage at disconnect switch. Voltage must be within range listed on the nameplate. If not, consult the power company and have voltage condition corrected before starting unit.

B-Heating Start-Up

⚠ WARNING

Shock and burn hazard.

G60UHV(X) units are equipped with a hot surface ignition system. Do not attempt to light manually.

- 1 - **STOP!** Read the safety information at the beginning of this section.
- 2 - Set the thermostat to the lowest setting.
- 3 - Turn off all electrical power to the unit.
- 4 - This furnace is equipped with an ignition device which automatically lights the burners. Do **not** try to light the burners by hand.
- 5 - Remove the upper access panel.
- 6 - *White Rodgers 36E Gas Valve* - Switch gas valve lever to **OFF**. See figure 17.
Honeywell VR8205 Gas Valve - Turn knob on gas valve clockwise ➡ to **OFF**. Do not force. See figure 18.
- 7 - Wait five minutes to clear out any gas. If you then smell gas, **STOP!** Immediately call your gas supplier from a neighbor's phone. Follow the gas supplier's instructions. If you do not smell gas go to next step.

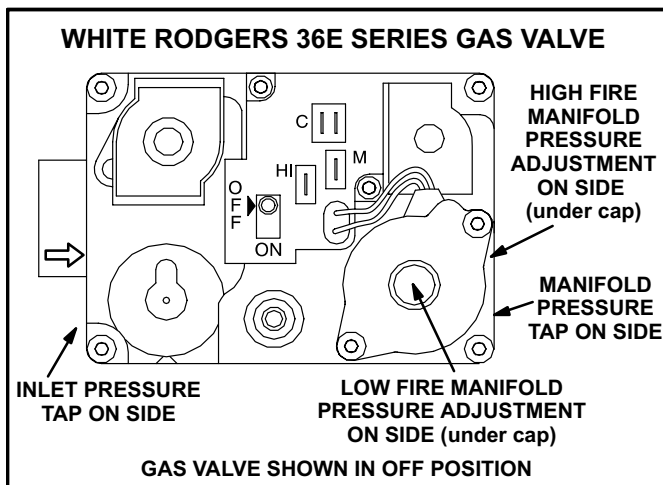

FIGURE 17

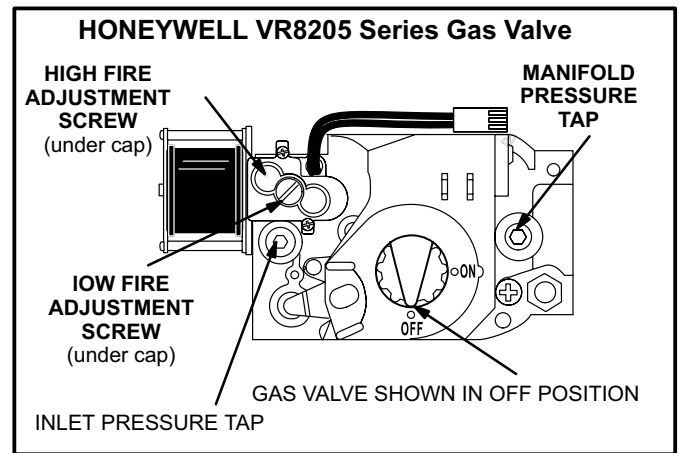

FIGURE 18

- 8 - *White Rodgers 36E Gas Valve* - Switch gas valve lever to **ON**. See figure 17.
Honeywell VR8205 Gas Valve - Turn knob on gas valve counterclockwise ↶ to **ON**. Do not force. See figure 18.
- 9 - Replace the upper access panel.
- 10 - Turn on all electrical power to the unit.
- 11 - Set the thermostat to desired setting.

NOTE - When unit is initially started, steps 1 through 11 may need to be repeated to purge air from gas line.

Turning Off Gas To Unit

- 1 - Set thermostat to lowest setting.
- 2 - Turn off all electrical power to unit if service is to be performed.
- 3 - Remove access panel.
- 4 - Switch lever on White Rodgers gas valve to **OFF**; turn knob on Honeywell valve clockwise ➡ to **OFF**. Do not force.
- 5 - Replace access panel.

C-Safety or Emergency Shutdown

Turn off unit power. Close manual and main gas valves.

D-Extended Period Shutdown

Turn off thermostat or set to "UNOCCUPIED" mode. Close all gas valves (both internal and external to unit) to guarantee no gas leak into combustion chamber. Turn off power to unit. All access panels and covers must be in place and secured.

IV-HEATING SYSTEM SERVICE CHECKS

A-C.S.A. Certification

All units are C.S.A. (formally A.G.A. and C.G.A. combined) design certified without modifications. Refer to the G60UHV(X) Installation Instruction.

B-Gas Piping

⚠ CAUTION

If a flexible gas connector is required or allowed by the authority that has jurisdiction, black iron pipe shall be installed at the gas valve and extend outside the furnace cabinet.

⚠ WARNING

Do not exceed 600 in-lbs (50 ft-lbs) torque when attaching the gas piping to the gas valve.

Gas supply piping should not allow more than 0.5"W.C. drop in pressure between gas meter and unit. Supply gas pipe must not be smaller than unit gas connection.

Compounds used on gas piping threaded joints should be resistant to action of liquefied petroleum gases.

C-Testing Gas Piping

⚠ IMPORTANT

In case emergency shutdown is required, turn off the main shut-off valve and disconnect the main power to unit. These controls should be properly labeled by the installer.

When pressure testing gas lines, the gas valve must be disconnected and isolated. Gas valves can be damaged if subjected to more than 0.5 psig (14" W.C.). See figure 19. If the pressure is equal to or less than 0.5psig (14"W.C.), use the manual shut-off valve before pressure testing to isolate furnace from gas supply.

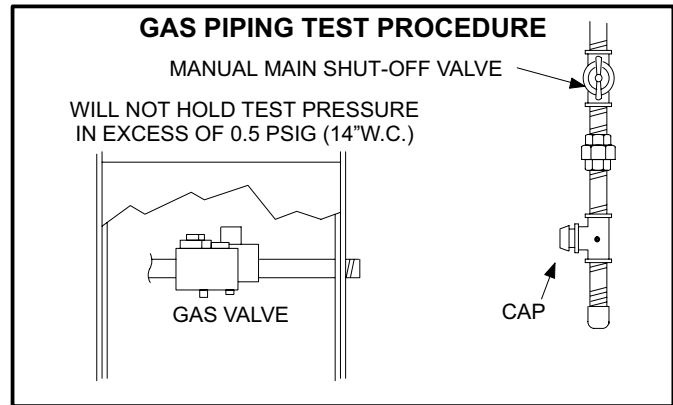

FIGURE 19

When checking piping connections for gas leaks, use preferred means. Kitchen detergents can cause harmful corrosion on various metals used in gas piping. Use of a specialty Gas Leak Detector is strongly recommended. It is available through Lennox under part number 31B2001. See Corp. 8411-L10, for further details.

Do not use matches, candles, flame or any other source of ignition to check for gas leaks.

D-Testing Gas Supply Pressure

When testing supply gas pressure, connect test gauge to inlet pressure tap on the gas valve See figure 17 or 18. Check gas line pressure with unit firing at maximum rate. Low pressure may result in erratic operation or underfire. High pressure can result in permanent damage to gas valve or overfire. See table 29 for operating pressure at unit gas connection (line).

On multiple unit installations, each unit should be checked separately, with and without units operating. Supply pressure must fall within range listed in table 29.

E-Check Manifold Pressure

After line pressure has been checked and adjusted, check manifold pressure. Move pressure gauge to outlet pressure tap located on unit gas valve (GV1). Checks of manifold pressure are made as verification of proper regulator adjustment. Manifold pressure for the G60UHV(X) can be measured at any time the gas valve is open and is supplying gas to the unit. See table 29 for normal operating manifold pressure. See HIGH ALTITUDE table (table of contents) for high altitude manifold pressures.

TABLE 29

All G60UHV Units	Natural	LP
Line Pressure WC"	4.5 - 10.5	11.0 - 13.0
Manifold Pressure High Heat WC"	3.5	10.0
Manifold Pressure Low Heat WC"	1.7	4.9

⚠ IMPORTANT

For safety, connect a shut-off valve between the manometer and the gas tap to permit shut off of gas pressure to the manometer.

The gas valve is factory set and should not require adjustment. All gas valves are factory regulated.

Manifold Adjustment Procedure:

- 1 - Connect a test gauge to manifold pressure tap on gas valve. See figure 17 or 18 for tap location. Start unit and allow 5 minutes for unit to reach steady state.
- 2 - While waiting for the unit to stabilize, notice the flame. Flame should be stable and should not lift from burner. Natural gas should burn blue. L.P. gas should burn mostly blue with some orange streaks.
- 3 - After allowing unit to stabilize for 5 minutes, record manifold pressure.

NOTE-Shut unit off and remove manometer as soon as an accurate reading has been obtained. Take care to replace pressure tap plug.

F- Proper Gas Flow (Approximate)

Furnace should operate at least 5 minutes before checking gas flow. Determine time in seconds for **two** revolutions of gas through the meter. (Two revolutions assures a more accurate time.) **Divide by two** and compare to time in table 30 below. If manifold pressure matches table 29 and rate is incorrect, check gas orifices for proper size and restriction.

NOTE- To obtain accurate reading, shut off all other gas appliances connected to meter.

TABLE 30

GAS METER CLOCKING CHART				
G60UH Unit	Seconds for One Revolution			
	Natural		LP	
	1 cu ft Dial	2 cu ft Dial	1 cu ft Dial	2 cu ft DIAL
-70	55	110	136	272
-90	41	82	102	204
-110	33	66	82	164
-135	27	54	68	136

Natural-1000 btu/cu ft LP-2500 btu/cu ft

⚠ IMPORTANT

For safety, shut unit off and remove manometer as soon as an accurate reading has been obtained. Take care to replace pressure tap plug.

G- Proper Combustion

Furnace should operate minimum 15 minutes with correct manifold pressure and gas flow rate before checking combustion. See sections E- and F-. Take combustion sample beyond the flue outlet and compare to the tables below. The maximum carbon monoxide reading should not exceed 100 ppm.

**TABLE 31
High Heat**

Unit	CO₂% For Nat	CO₂% For L.P.
G60UHV-36A-070(X)	7.2 - 8.2	8.0 - 9.0
G60UHV-36B-090	7.5 - 8.5	8.5 - 9.5
G60UHV-60C-090(X)	7.5 - 8.5	8.5 - 9.5
G60UHV-60C-110(X)	7.3 - 8.3	8.5 - 9.5
G60UHV-60D-135	7.5 - 8.5	8.8 - 9.8

**TABLE 32
Low Heat**

Unit	CO₂% For Nat	CO₂% For L.P.
G60UHV-36A-070(X)	4.2 - 5.2	5.0 - 6.0
G60UHV-36B-090	4.7 - 5.7	5.0 - 6.0
G60UHV-60C-090(X)	4.5 - 5.5	5.0 - 6.0
G60UHV-60C-110(X)	4.5 - 5.5	5.3 - 6.3
G60UHV-60D-135	4.7 - 5.7	5.8 - 6.8

H-Flame Signal

A microamp DC meter is needed to check the flame signal on the ignition control.

Flame (microamp) signal is an electrical current which passes from the furnace control through the sensor during unit operation. Current passes from the sensor through the flame to ground to complete a safety circuit.

To Measure Flame Signal - Ignition Control:

A transducer (Part #78H5401 available from Lennox Repair Parts) is required to measure flame signal if meter used will not read a low micro amp signal. See figure 20. The transducer converts microamps to volts on a 1:1 conversion. See figure 13 or 14 for flame signal. A digital readout meter must be used. The transducer plugs into most meters. See figure 21 for proper use of transducer.

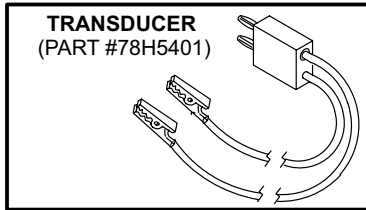

FIGURE 20

- 1 - Set the volt meter to the DC voltage scale. Insert transducer into the VDC and common inputs. Observe correct polarities. Failure to do so results in negative (-) values.
- 2 - Turn off supply voltage to control.
- 3 - Disconnect ignition control flame sensor wire from the flame sensor.
- 4 - Connect (-) lead of the transducer to flame sensor.
- 5 - Connect (+) lead of transducer to the ignition control sensor wire.
- 6 - Turn supply voltage on and close thermostat contacts to cycle system.
- 7 - When main burners are in operation for two minutes, take reading. Remember 1 DC volt = 1 DC microamp.

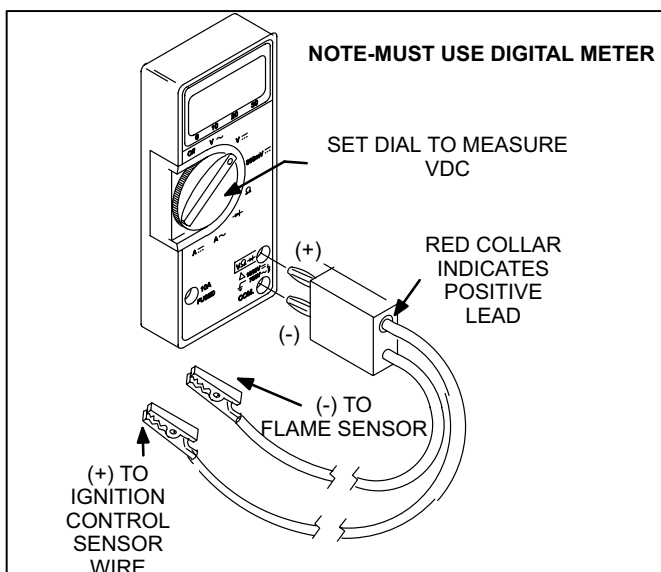

FIGURE 21

V-TYPICAL OPERATING CHARACTERISTICS

A-Blower Operation and Adjustment

When the thermostat is set to "FAN ON," the indoor blower will run continuously at approximately 38% of the second-stage cooling speed when there is no cooling or heating demand.

When the G60UHV(X) is running in the heating mode, the indoor blower will run on the heating speed designated by the positions of dip switches 11 and 12.

When there is a cooling demand, the indoor blower will run on the cooling speed designated by the positions of dip switches 5 and 6.

B-Temperature Rise

Temperature rise for G60UHV(X) units depends on unit input, blower speed, blower horsepower and static pressure as marked on the unit rating plate. The blower speed must be set for unit operation within the range of "TEMP. RISE °F" listed on the unit rating plate.

To Measure Temperature Rise:

- 1 - Place plenum thermometers in the supply and return air plenums. Locate supply air thermometer in the first horizontal run of the plenum where it will not pick up radiant heat from the heat exchanger.
- 2 - Set thermostat to highest setting.
- 3 - After plenum thermometers have reached their highest and steadiest readings, subtract the two readings. The difference should be in the range listed on the unit rating plate. If the temperature is too low, decrease blower speed. If temperature is too high, first check the firing rate. Provided the firing rate is acceptable, increase blower speed to reduce temperature. To change blower speed taps see the Blower Speed Taps section in this manual.

C-External Static Pressure

- 1 - Tap locations shown in figure 22.
- 2 - Punch a 1/4" diameter hole in supply and return air plenums. Insert manometer hose flush with inside edge of hole or insulation. Seal around the hose with perma-gum. Connect the zero end of the manometer to the discharge (supply) side of the system. On ducted systems, connect the other end of manometer to the return duct as above. For systems with non-ducted returns, leave the other end of the manometer open to the atmosphere.
- 3 - With only the blower motor running and the evaporator coil dry, observe the manometer reading. Adjust blower motor speed to deliver the air desired according to the job requirements.
- 4 - External static pressure drop must not be more than 0.8" W.C.
- 5 - Seal around the hole when the check is complete.

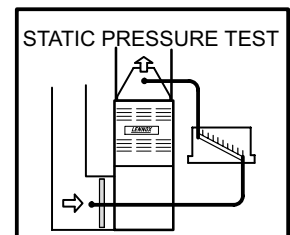

FIGURE 22

VI-MAINTENANCE

⚠ WARNING

Disconnect power before servicing unit.

⚠ CAUTION

Label all wires prior to disconnection when servicing controls. Wiring errors can cause improper and dangerous operation. Verify proper operation after servicing.

At the beginning of each heating season, a qualified technician should check the system as follows:

A-Blower

Check the blower wheel for debris and clean if necessary. The blower motors are prelubricated for extended bearing life. No further lubrication is needed.

⚠ WARNING

The blower access panel must be securely in place when the blower and burners are operating. Gas fumes, which could contain carbon monoxide, can be drawn into living space resulting in personal injury or death.

B-Filters

All G60UHV(X) filters are installed external to the unit. Filters should be inspected monthly. Clean or replace the filters when necessary to ensure that the furnace operates properly. Replacement filters must be rated for high velocity airflow.

C-Flue and Chimney

Check the flue pipe, chimney and all connections for tightness and to make sure there is no blockage.

D-Electrical

- 1 - Check all wiring for loose connections.
- 2 - Check for the correct voltage at the furnace (furnace operating).
- 3 - Check amp-draw on the blower motor.
Motor Nameplate _____ Actual _____

E-Heat Exchanger and Burners

NOTE - Use papers or protective covering in front of the furnace during cleaning.

Cleaning the heat exchanger requires a steel spring "snake," a reversible drill and a vacuum cleaner. The steel spring snake may be constructed by purchasing a 4 ft. long by 1/4 inch diameter steel wire cable and a 1/4 inch diame-

ter wire brush. These items are available at a hardware store. Insert wire end of brush into the open end of the spring cable. Crimp the cable around the brush so that the brush is secured and will not come off during cleaning. Attach the other end of the cable to the reversible drill to complete the tool for cleaning the heat exchanger.

- 1 - Turn off both electrical and gas power supplies to furnace.
- 2 - Remove flue pipe and top cap from the unit. Label the pressure switch wires, then disconnect them.
- 3 - Remove the four screws that secure the combustion air inducer. Carefully remove the combustion air inducer to avoid damaging blower gasket. If gasket is damaged, it must be replaced to prevent leakage.

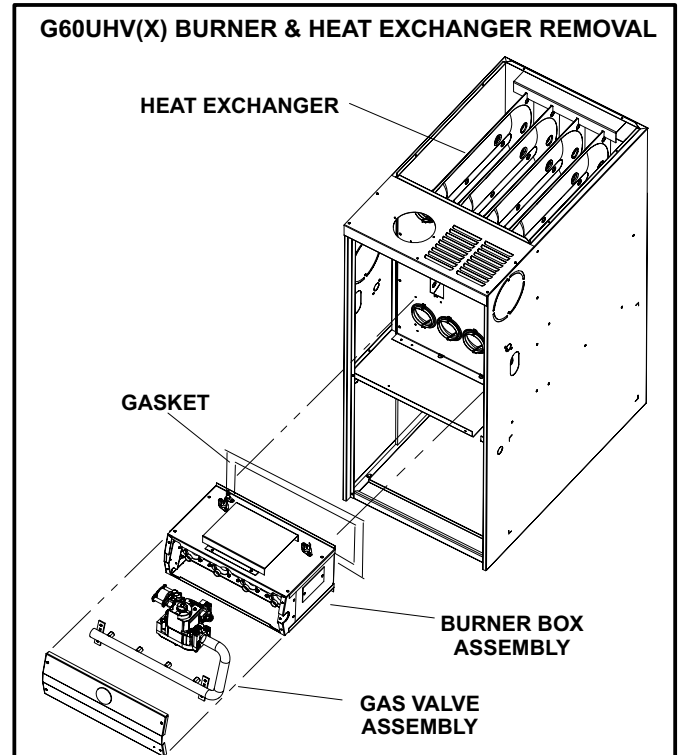

FIGURE 23

- 4 - Remove the collector box located behind the combustion air inducer. Be careful with the collector box gasket. If the gasket is damaged, it must be replaced to prevent leakage.
- 5 - Label the wires from gas valve and rollout switches, then disconnect them.
- 6 - Remove the four screws securing the burner box cover and remove the cover.
- 7 - Disconnect gas supply piping. Remove six screws securing the burner box / manifold assembly to the vestibule panel and remove the assembly from the unit. Take care not to damage the gasket.

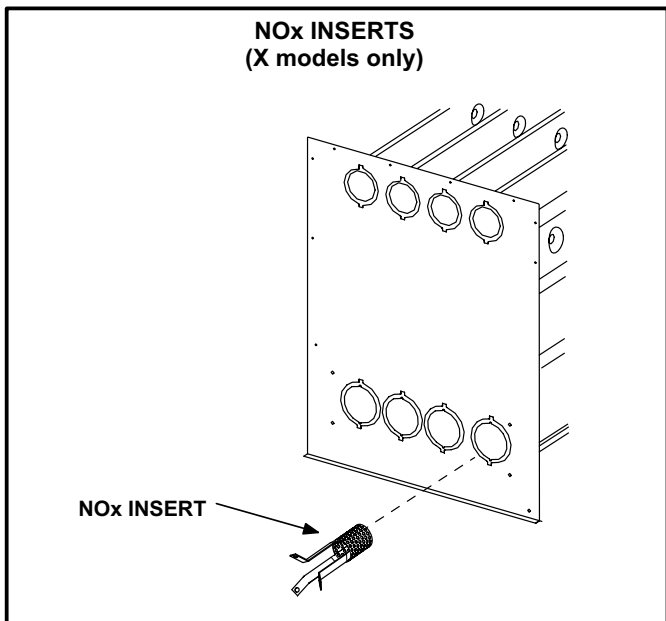

FIGURE 24

- 8 - **NOx units only** - Remove the three screws that attach the NOx insert to the corbel at the entrance to each heat exchanger section. Carefully remove the NOx insert from each section. See figure 24.
- 9 - Insert the brush end of cable snake into the top of one of the heat exchanger openings. **Do not force the cable into the heat exchanger.** Insert the cable and operate the drill on slow speed. Move the cable in and out of the heat exchanger section three or four times or until sufficient cleaning is accomplished. Reverse drill and slowly work the cable out of opening.
- 10- Repeat procedure for each heat exchanger section.
- 11- After each of the top heat exchanger sections has been cleaned, insert the brush end of the cable snake into the bottom openings of each of the heat exchanger sections and clean as described in step 8.
- 12- Remove the cable from the heat exchanger. Use a vacuum cleaner to remove debris knocked loose during cleaning.
NOTE - Safety glasses and surgical mask should be worn when using vacuum cleaner.
- 13- Attach the exhaust end (positive pressure) of the vacuum cleaner to the top of the heat exchanger section. Any loose debris will be forced to the bottom of the heat exchanger section. Vacuum debris from bottom openings.

- 14- Replace collector box and combustion air inducer. Check gaskets for damage. Damaged gaskets must be replaced to avoid heat exchanger leaks. Replace all screws to the collector box and combustion air inducer. Failure to replace all screws may cause leaks.
 - 15- To clean the burner, run a vacuum cleaner with a soft brush attachment over the face of burners. Visually inspect inside the burners and crossovers for any blockage caused by foreign matter. Remove any blockage.
 - 16- **NOx units only** - Reattach the NOx inserts to the corbels at the entrance to each heat exchanger opening. See figure 24.
 - 17- Re-install gasket and burner box / manifold assembly onto the vestibule panel. Replace burner box cover and re-secure using screws.
NOTE - Gasket must be replaced if it was damaged during disassembly.
 - 18- Reconnect wires to pressure switch, roll-out switches, gas valve and combustion air inducer. Refer to unit wiring diagram.
 - 19- Re-install top cap and re-secure vent pipe to combustion air inducer outlet.
 - 20- Reconnect gas supply piping.
 - 21- Turn on power and gas supply to unit.
 - 22- Set thermostat and check for proper operation.
 - 23- Check all piping connections, factory and field, for gas leaks. Use a leak detecting solution or other preferred means.
- ⚠ CAUTION**

Some soaps used for leak detection are corrosive to certain metals. Carefully rinse piping thoroughly after leak test has been completed. Do not use matches, candles, flame or other sources of ignition to check for gas leaks.
- 24- If a leak is detected, shut gas and electricity off and repair leak.
 - 25- Repeat steps 23 and 24 until no leaks are detected.
 - 26- Replace front access panel.

VII- Wiring and Sequence of Operation

A-Wiring Diagram for G60UHV-1, -2 and -3 units

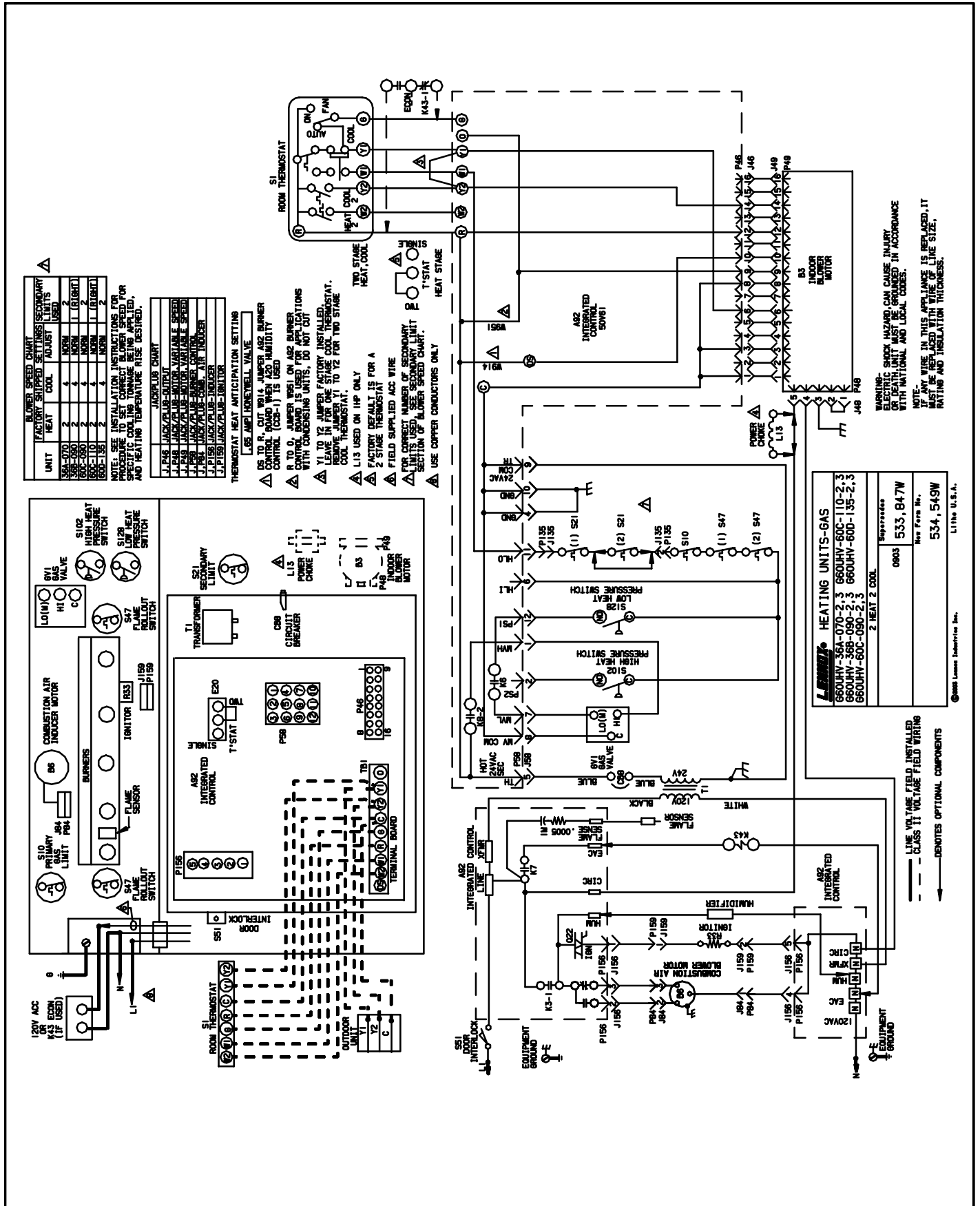

B-Sequence of Operation

Sequence depends on type thermostat used. G60UHV units are applicable for single stage or two stage thermostats. Both type thermostats are described below. Thermostat jumper E20 dictates which mode unit will operate in. See flow chart for more sequence detail.

SureLight Control Self Check

When there is a call for heat, the SureLight integrated control runs a self check. The control checks for S10 primary limit, S21 secondary limit (s) and S47 rollout switch normally closed contacts. The control also checks for S102 high heat and S128 low heat prove switch normally open contacts. Once self check is complete and all safety switches are operational, heat call can continue.

Two-Stage Thermostat, Two Stage Heat. Jumper E20 set at "TWO".

- 1- SureLight control energizes combustion air inducer B6 on low heat speed. Combustion air inducer runs until S128 low heat prove switch contacts close (switch must close within 2 1/2 minutes or control goes into Watchguard Pressure Switch mode. High heat prove switch S102 may also close). A 15 second pre-purge follows once S128 closes.
- 2- SureLight control begins 20 second ignitor warm up period.
- 3- Gas valve opens on first stage for a 4 second trial for ignition. Ignitor stays energized during the trial or until flame sensed.
- 4- Flame is sensed, gas valve remains on first stage heat, ignitor de-energizes.
- 5- After 45 second delay, indoor blower B3 is energized on low heat speed.
The furnace will stay in this mode until first stage demand is satisfied OR a second stage heat demand is initiated.
- 6- Second stage heat demand initiated. A 30 second second stage recognition period begins.
- 7- The combustion air inducer ramps up to high heat speed.
- 8- S102 high heat prove switch closes and the gas valve energizes second stage heat.
- 9- B3 indoor blower ramps up to high heat speed.

Single-Stage Thermostat, Two Stage Heat. Jumper E20 set at "SINGLE"

- 1- SureLight control energizes combustion air inducer B6 on low heat speed. Combustion air inducer runs until S128 low heat prove switch contacts close (switch must close within 2 1/2 minutes or control goes into Watchguard Pressure Switch mode. High heat prove switch S102 may also close). A 15 second pre-purge follows once S128 closes.
- 2- SureLight control begins 20 second ignitor warm up period.
- 3- Gas valve opens on first stage for a 4 second trial for ignition. Ignitor stays energized during the trial or until flame sensed.
- 4- Flame is sensed, gas valve remains on first stage heat, ignitor de-energizes.
- 5- After 45 second delay, indoor blower B3 is energized on low heat speed.
- 6- A 10 minute (factory set) or 15 minute (field set) second stage heat delay period begins.
- 7- After the delay the combustion air inducer ramps up to high heat speed.
- 8- S102 high heat prove switch closes and the gas valve energizes second stage heat.
- 9- B3 indoor blower ramps up to high heat speed.

C-Flow Chart SureLight Boards 18M99 & 49M59

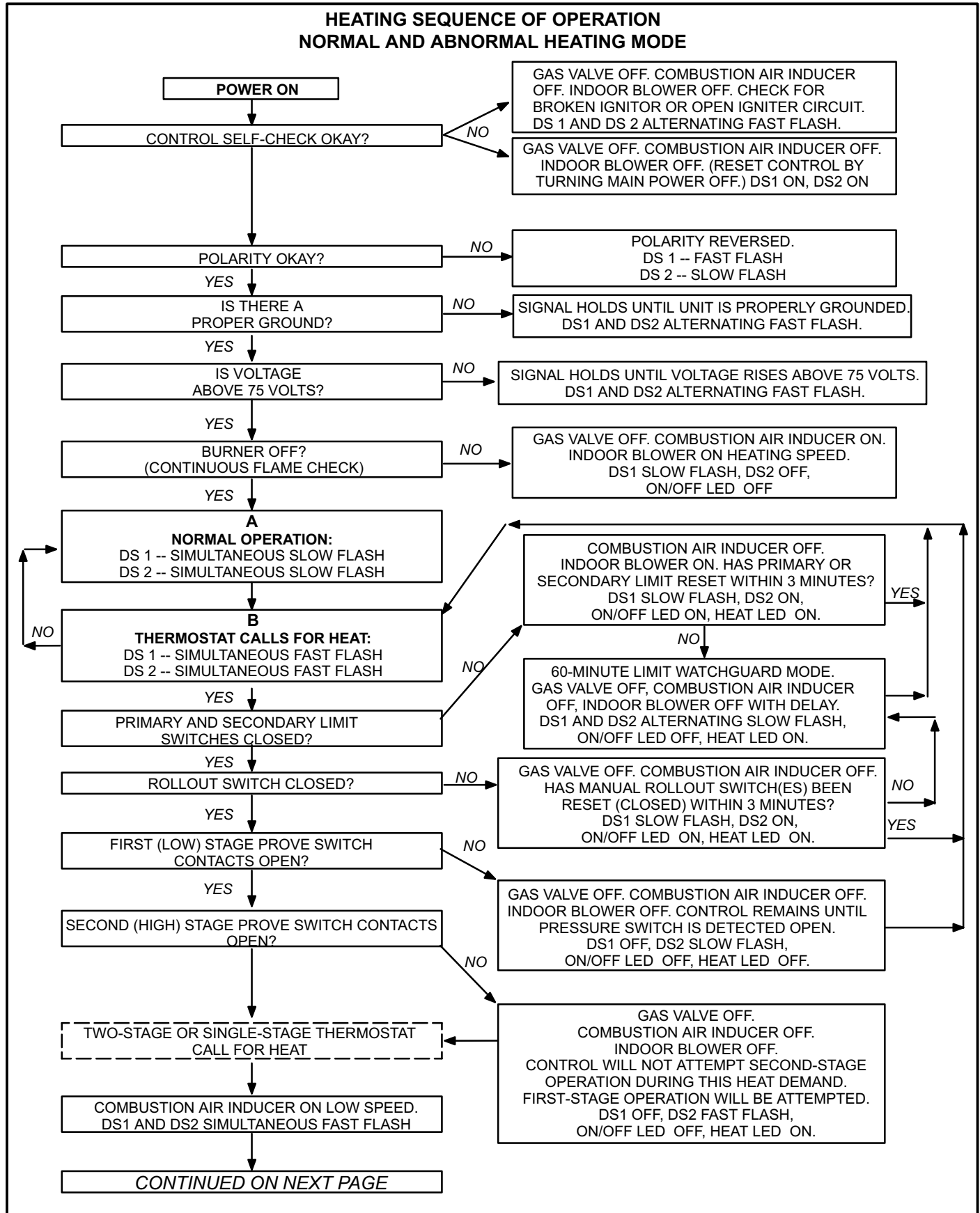

HEATING SEQUENCE OF OPERATION

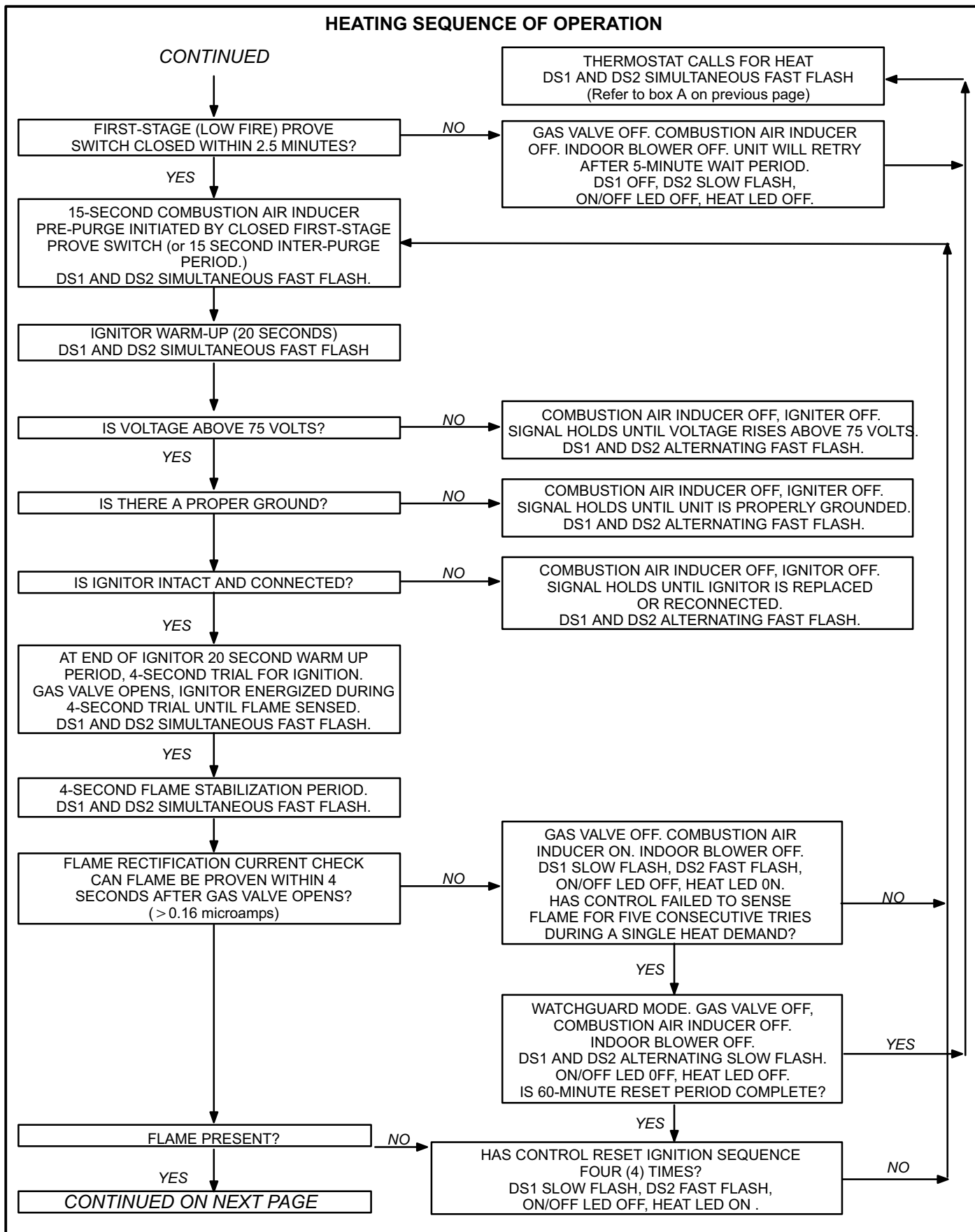

HEATING SEQUENCE OF OPERATION

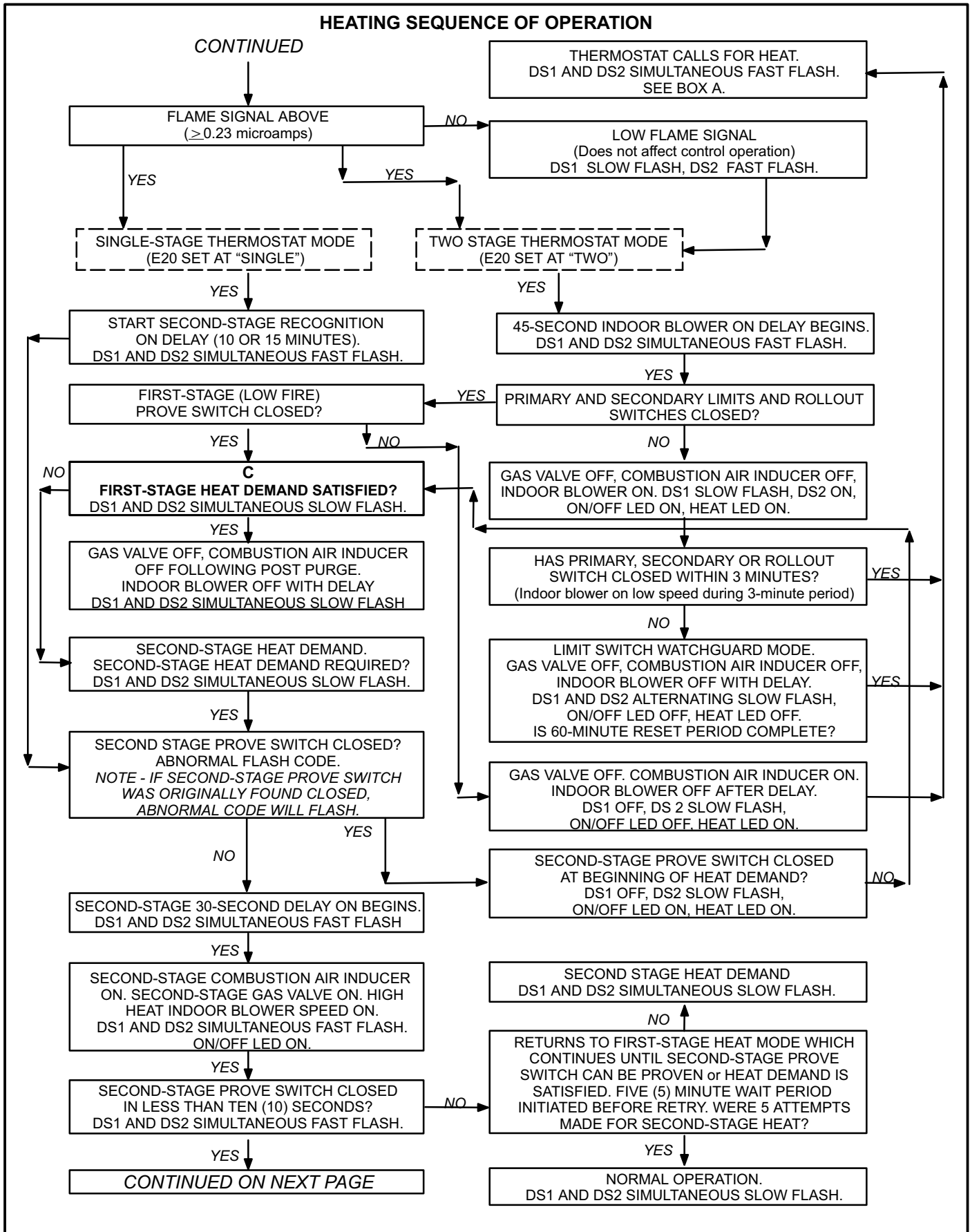

HEATING SEQUENCE OF OPERATION

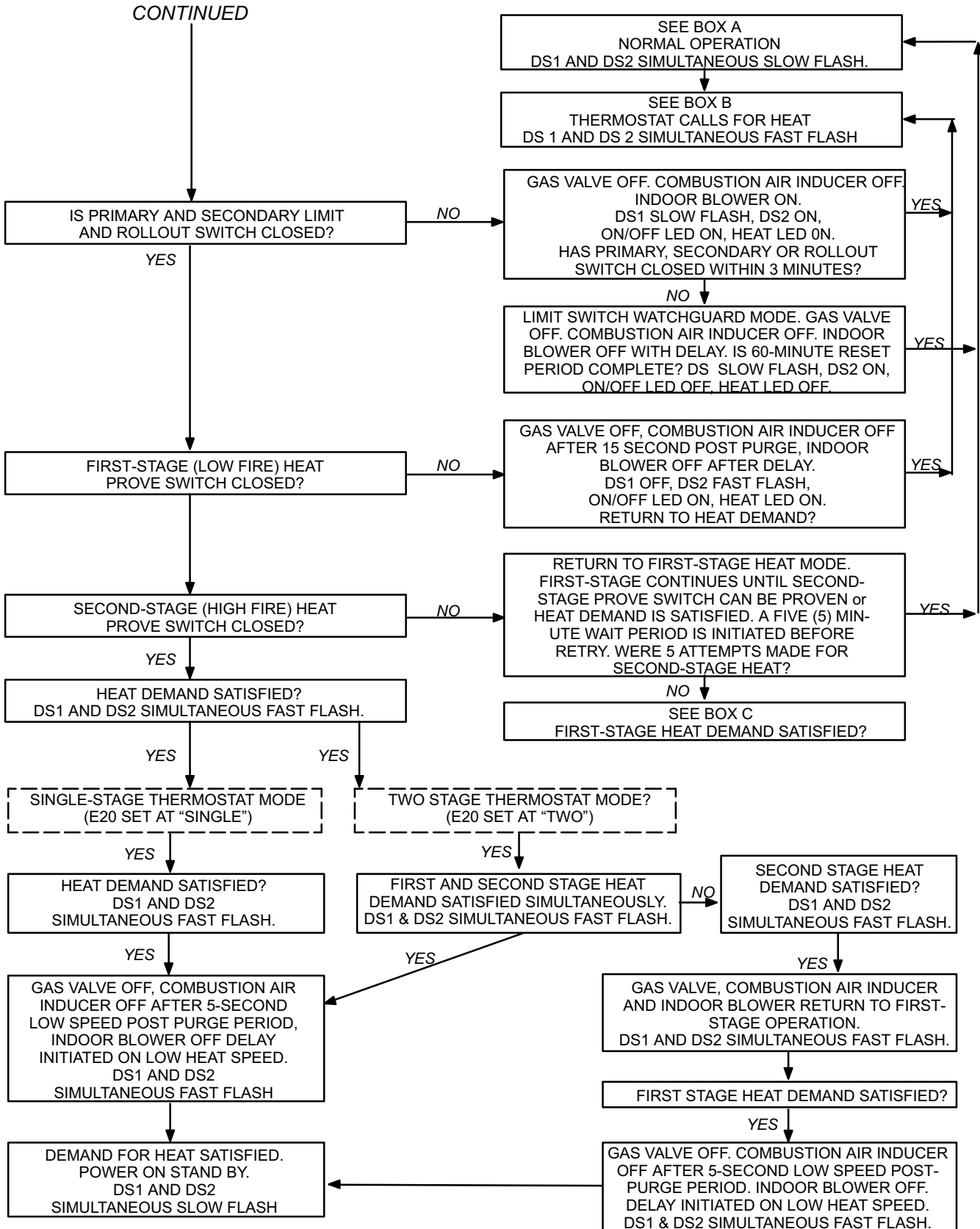

COOLING SEQUENCE OF OPERATION

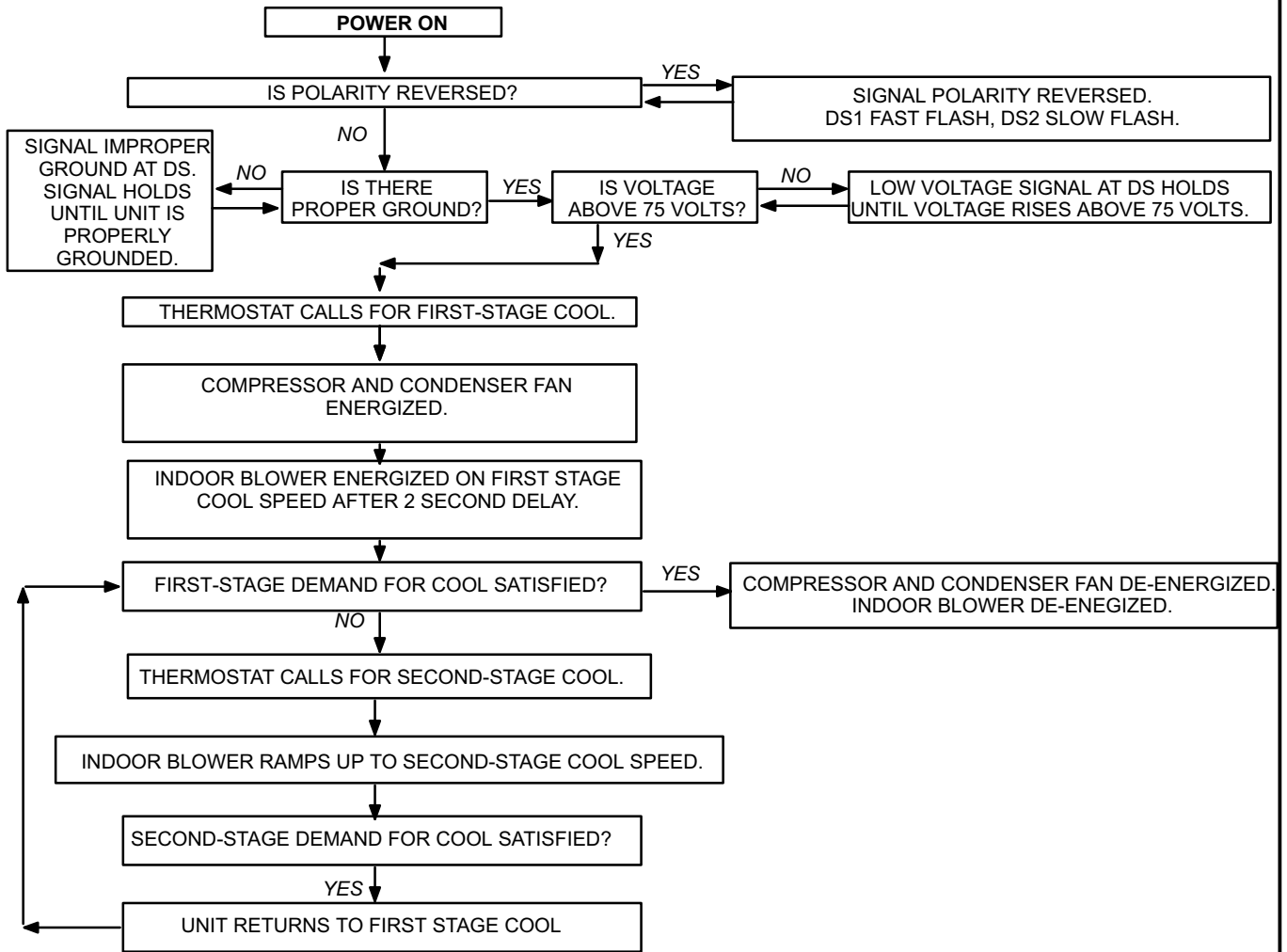

CONTINUOUS LOW SPEED FAN SEQUENCE OF OPERATION

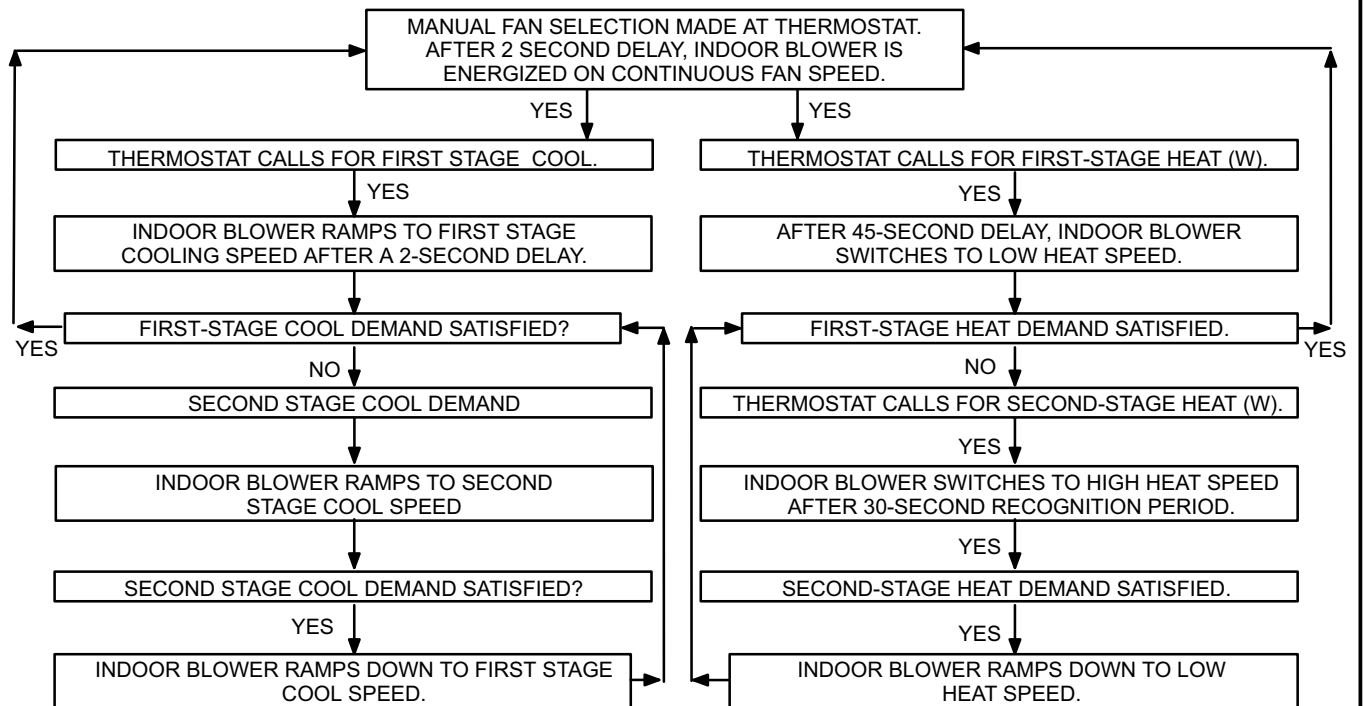

D-Wiring Diagram for G60UHV-7 and later

- ▲ CUT W914 JUMPER LABELED "DEHUM OR HARMONY" FROM DS TO R, AT A92 CONTROL BOARD WHEN USED WITH SIGNATURE STAT.
- ▲ CUT W951 JUMPER FROM D TO R, LABELED "HEAT PUMP", AT A92 CONTROL BOARD, WHEN USED FOR DUAL FUEL APPLICATIONS.
- ▲ JUMPER W915 FROM Y1 TO Y2 IS FACTORY INSTALLED AT A92 CONTROL BOARD. LEAVE IN FOR ONE STAGE COOL THERMOSTAT. CUT JUMPER Y1 TO Y2 FOR TWO STAGE COOL THERMOSTAT.

- ▲ L13 USED ON IHP ONLY
- ▲ FACTORY DEFAULT IS FOR A 2 STAGE THERMOSTAT
- ▲ FIELD SUPPLIED ACC WIRE
- ▲ FOR CORRECT NUMBER OF SECONDARY LIMITS USED, SEE SECONDARY LIMIT SECTION OF BLOWER SPEED CHART.
- ▲ USE COPPER CONDUCTORS ONLY
- ▲ #1 TERMINAL IS USED FOR DIAGNOSTIC RECALL
- ▲ 24V POWER PROVIDED FOR OPTIONAL HUMIDIFIER DURING HEAT DEMAND

NOTE: SEE INSTALLATION INSTRUCTIONS FOR PROCEDURE TO SET CORRECT BLOWER SPEED FOR SPECIFIC COOLING TONNAGE BEING APPLIED, AND HEATING TEMPERATURE RISE DESIRED.
TYPICAL SYSTEM SHOWN FOR 2 HEAT/2 COOL WITH A CONVENTIONAL THERMOSTAT. SEE INSTALLATION INSTRUCTIONS FOR CONNECTIONS TO OTHER EQUIPMENT AND ACCESSORIES.

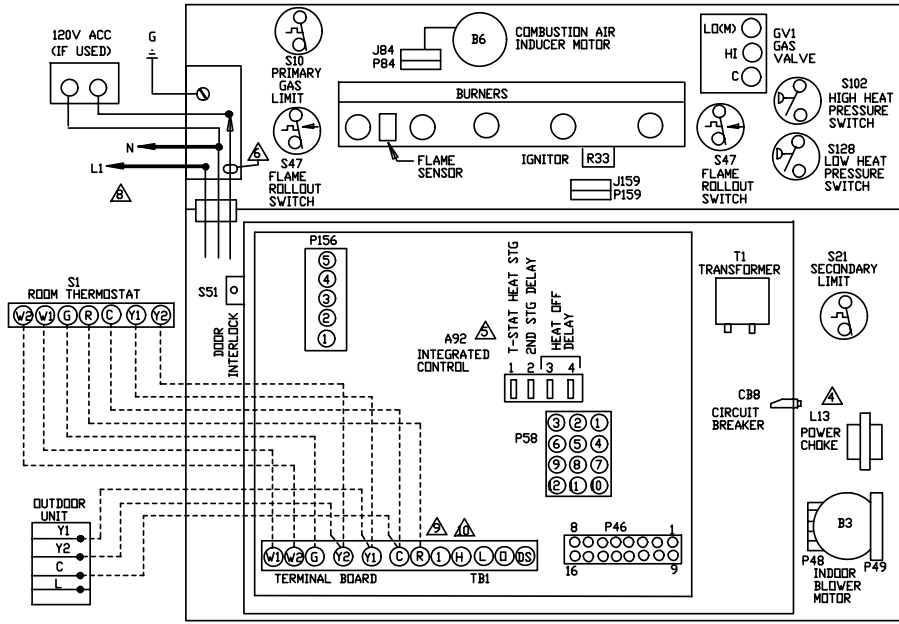

JACKPLUG CHART	
J.P46	JACK/PLUG-OUTPUT
J.P48	JACK/PLUG-MOTOR VARIABLE SPEED
J.P49	JACK/PLUG-MOTOR VARIABLE SPEED
J.P58	JACK/PLUG-BURNER CONTROL
J.P64	JACK/PLUG-COMB. AIR INDUCER
J.P135	JACK/PLUG-SECONDARY LIMIT
J.P156	JACK/PLUG-IGNITER
J.P159	JACK/PLUG-IGNITER

BLOWER SPEED CHART				
UNIT	HEAT	COOL	ADJUST	SECONDARY LIMITS USED
36A-070	2	4	NORM	2
36B-090	2	4	NORM	1 (RIGHT)
60C-090	2	4	NORM	2
60C-110	2	4	NORM	1 (RIGHT)
60D-19S	2	4	NORM	2

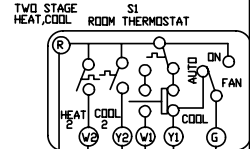

THERMOSTAT HEAT ANTICIPATION SETTING
1.65 AMP HONEYWELL VALVE

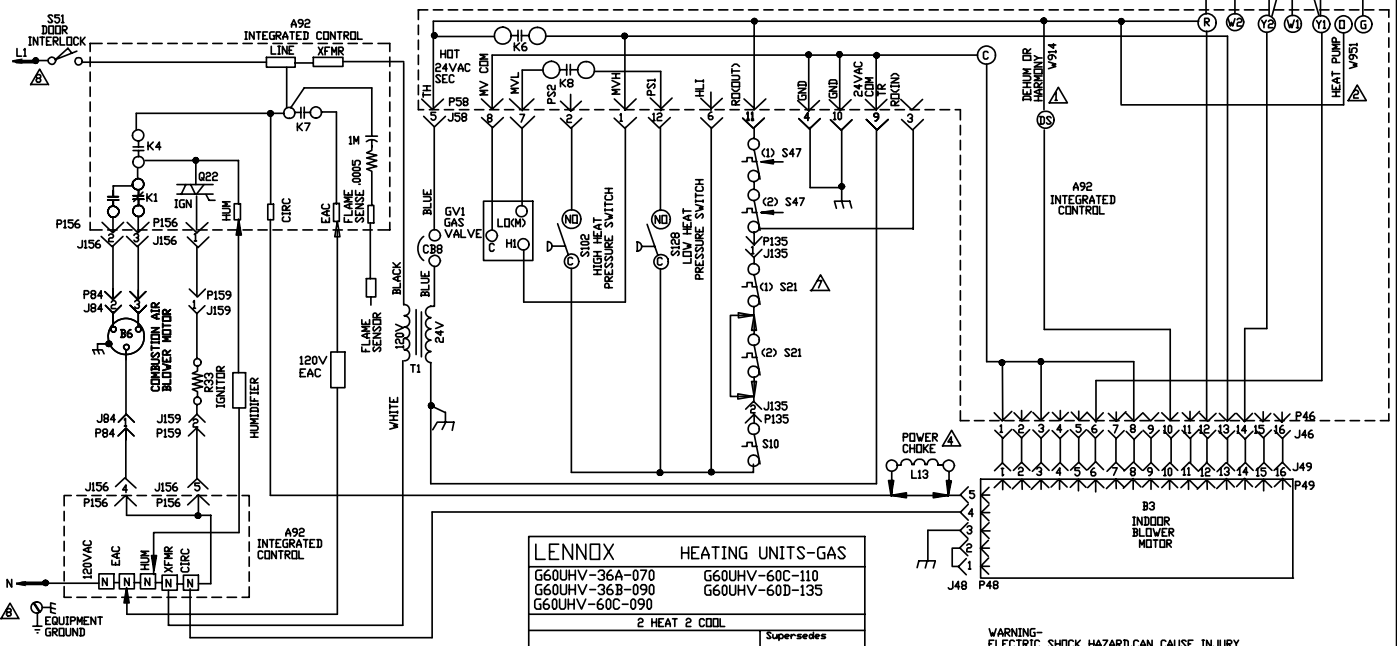

LENNOX HEATING UNITS-GAS

G60UHV-36A-070	G60UHV-60C-110
G60UHV-36B-090	G60UHV-60D-135
G60UHV-60C-090	

2 HEAT 2 COOL

0906

Supersedes

New Form No.
535,289W

© 2006 Litho U.S.A.

WARNING-
ELECTRIC SHOCK HAZARD, CAN CAUSE INJURY OR DEATH. UNIT MUST BE GROUNDED IN ACCORDANCE WITH NATIONAL AND LOCAL CODES.

NOTE-
IF ANY WIRE IN THIS APPLIANCE IS REPLACED, IT MUST BE REPLACED WITH WIRE OF LIKE SIZE, RATING, INSULATION THICKNESS, AND TERMINATION

--- LINE VOLTAGE FIELD INSTALLED
--- CLASS II VOLTAGE FIELD WIRING
--- DENOTES OPTIONAL COMPONENTS

E-Sequence of Operation

Sequence depends on type thermostat used. G60UHV units are applicable for single stage or two stage thermostats. Both type thermostats are described below. Thermostat dip switch selection dictates which mode unit will operate in. See flow chart for more sequence detail.

SureLight Control Self Check

When there is a call for heat, the SureLight integrated control runs a self check. The control checks for S10 primary limit, S21 secondary limit (s) and S47 rollout switch normally closed contacts. The control also checks for S102 high heat and S128 low heat prove switch normally open contacts. Once self check is complete and all safety switches are operational, heat call can continue.

Two-Stage Thermostat, Two Stage Heat. Dip Switch set at "TWO".

- 10- SureLight control energizes combustion air inducer B6 on low heat speed. Combustion air inducer runs until S128 low heat prove switch contacts close (switch must close within 2 1/2 minutes or control goes into Watchguard Pressure Switch mode. High heat prove switch S102 may also close). A 15 second pre-purge follows once S128 closes.
- 11- SureLight control begins 20 second ignitor warm up period.
- 12- Gas valve opens on first stage for a 4 second trial for ignition. Ignitor stays energized during the trial or until flame sensed.
- 13- Flame is sensed, gas valve remains on first stage heat, ignitor de-energizes.
- 14- After 45 second delay, indoor blower B3 is energized on low heat speed.
The furnace will stay in this mode until first stage demand is satisfied OR a second stage heat demand is initiated.
- 15- Second stage heat demand initiated. A 30 second second stage recognition period begins.
- 16- The combustion air inducer ramps up to high heat speed.
- 17- S102 high heat prove switch closes and the gas valve energizes second stage heat.
- 18- B3 indoor blower ramps up to high heat speed.

Single-Stage Thermostat, Two Stage Heat. Dip Switch set at "SINGLE"

- 1- SureLight control energizes combustion air inducer B6 on low heat speed. Combustion air inducer runs until S128 low heat prove switch contacts close (switch must close within 2 1/2 minutes or control goes into Watchguard Pressure Switch mode. High heat prove switch S102 may also close). A 15 second pre-purge follows once S128 closes.
- 2- SureLight control begins 20 second ignitor warm up period.
- 3- Gas valve opens on first stage for a 4 second trial for ignition. Ignitor stays energized during the trial or until flame sensed.
- 4- Flame is sensed, gas valve remains on first stage heat, ignitor de-energizes.
- 5- After 45 second delay, indoor blower B3 is energized on low heat speed.
- 6- A 10 minute (factory set) or 15 minute (field set) second stage heat delay period begins.
- 7- After the delay the combustion air inducer ramps up to high heat speed.
- 8- S102 high heat prove switch closes and the gas valve energizes second stage heat.
- 9- B3 indoor blower ramps up to high heat speed.

F-Flow Chart SureLight Board 100870

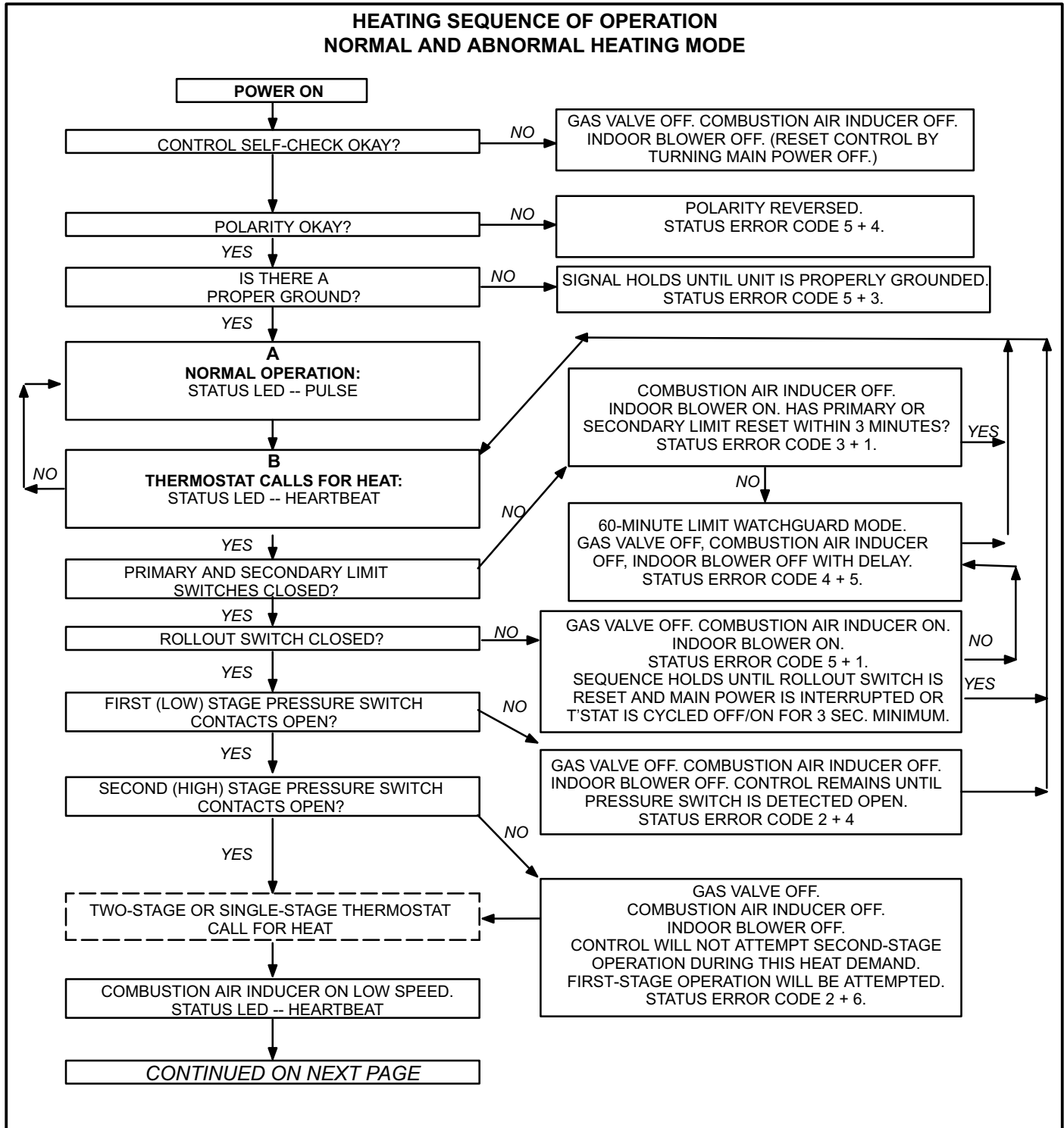

HEATING SEQUENCE OF OPERATION

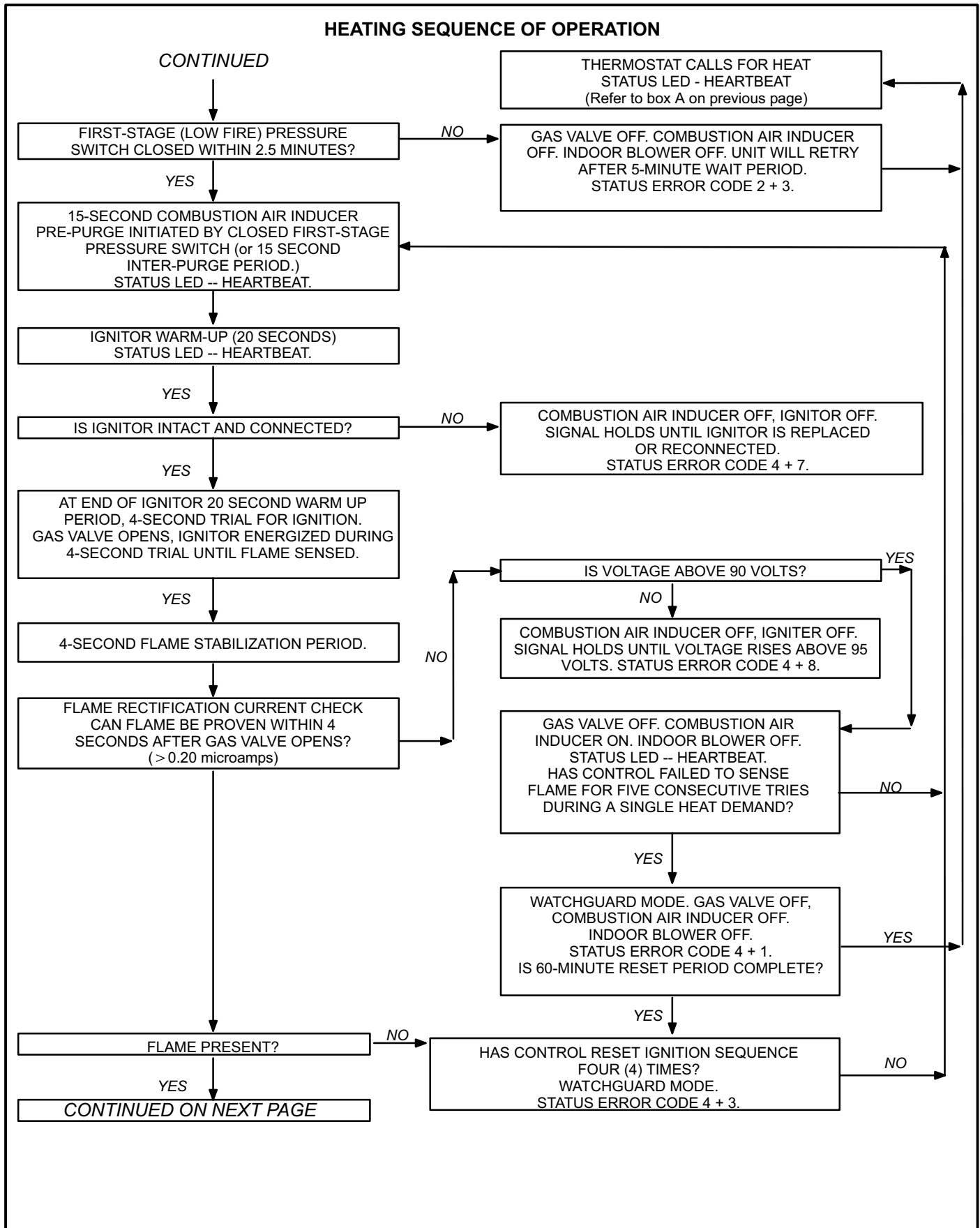

HEATING SEQUENCE OF OPERATION

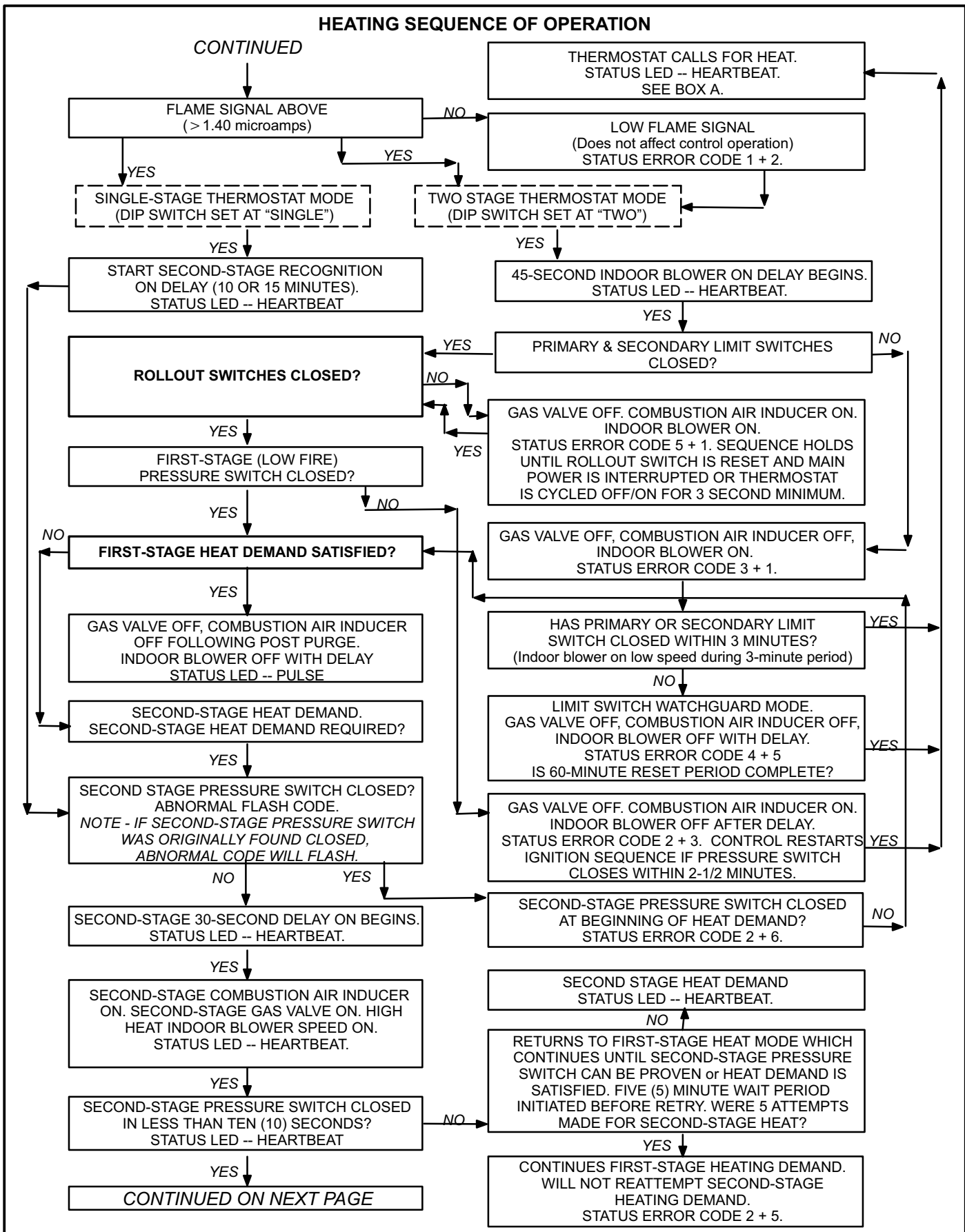

HEATING SEQUENCE OF OPERATION

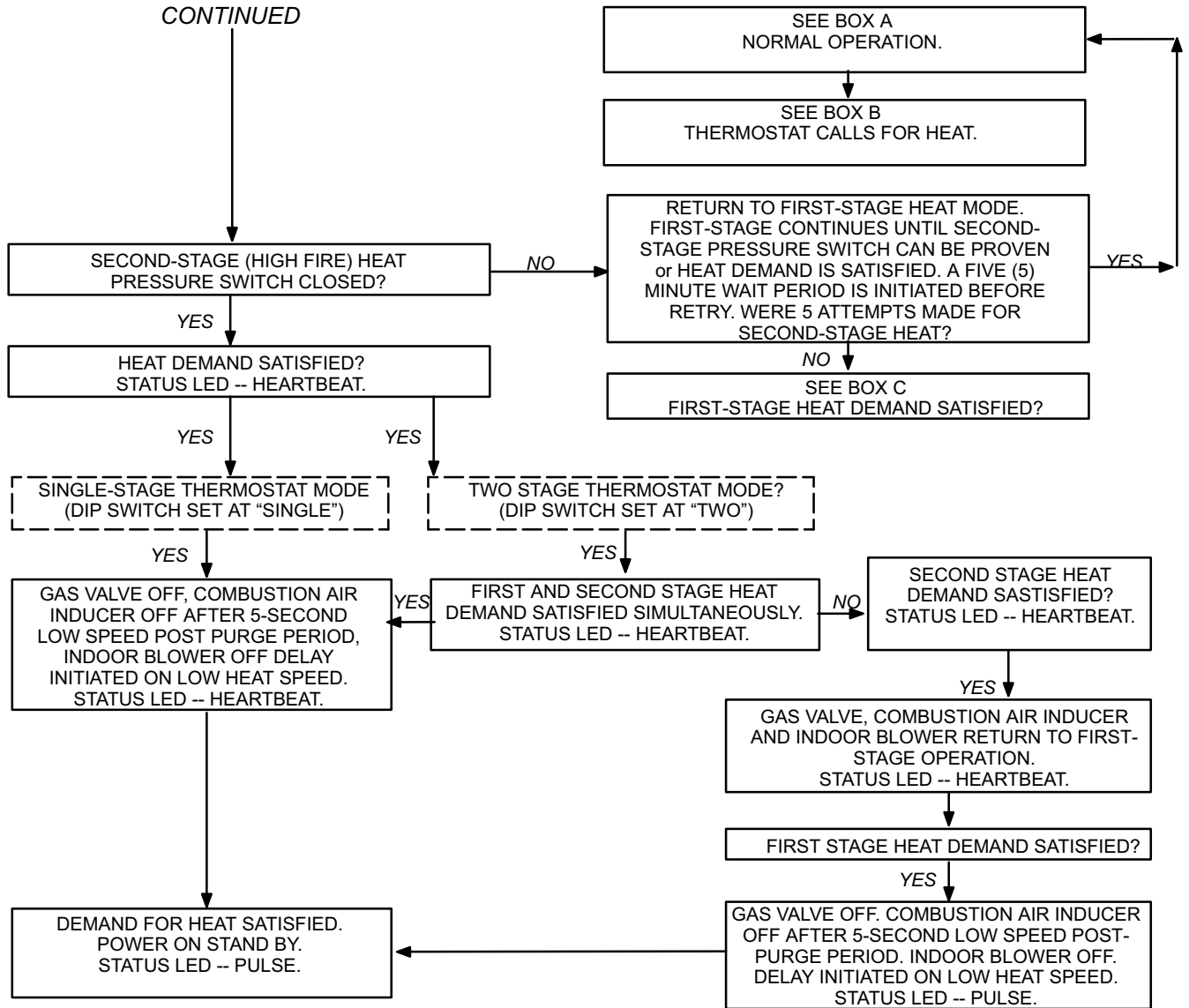

COOLING SEQUENCE OF OPERATION

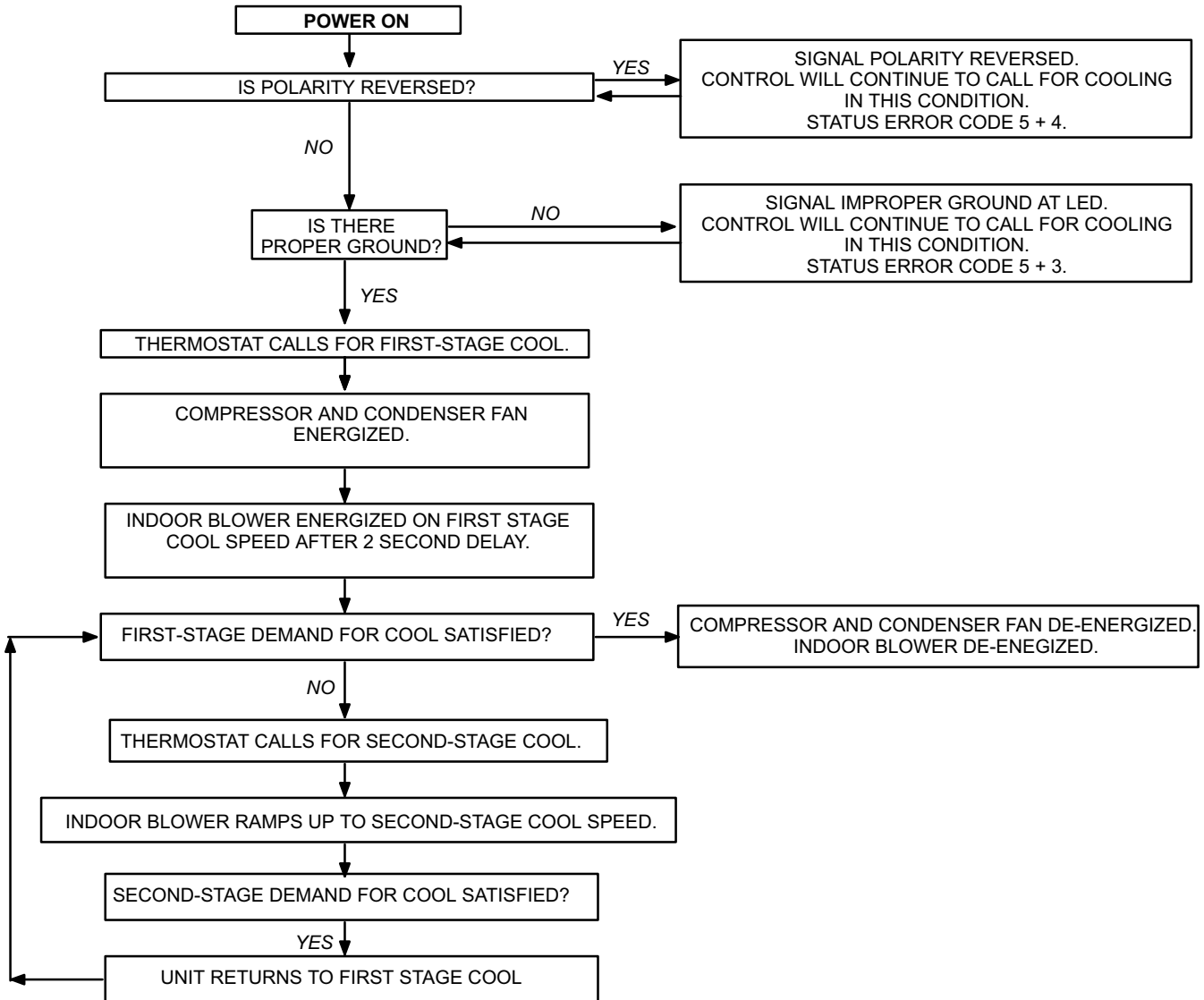

CONTINUOUS LOW SPEED FAN SEQUENCE OF OPERATION

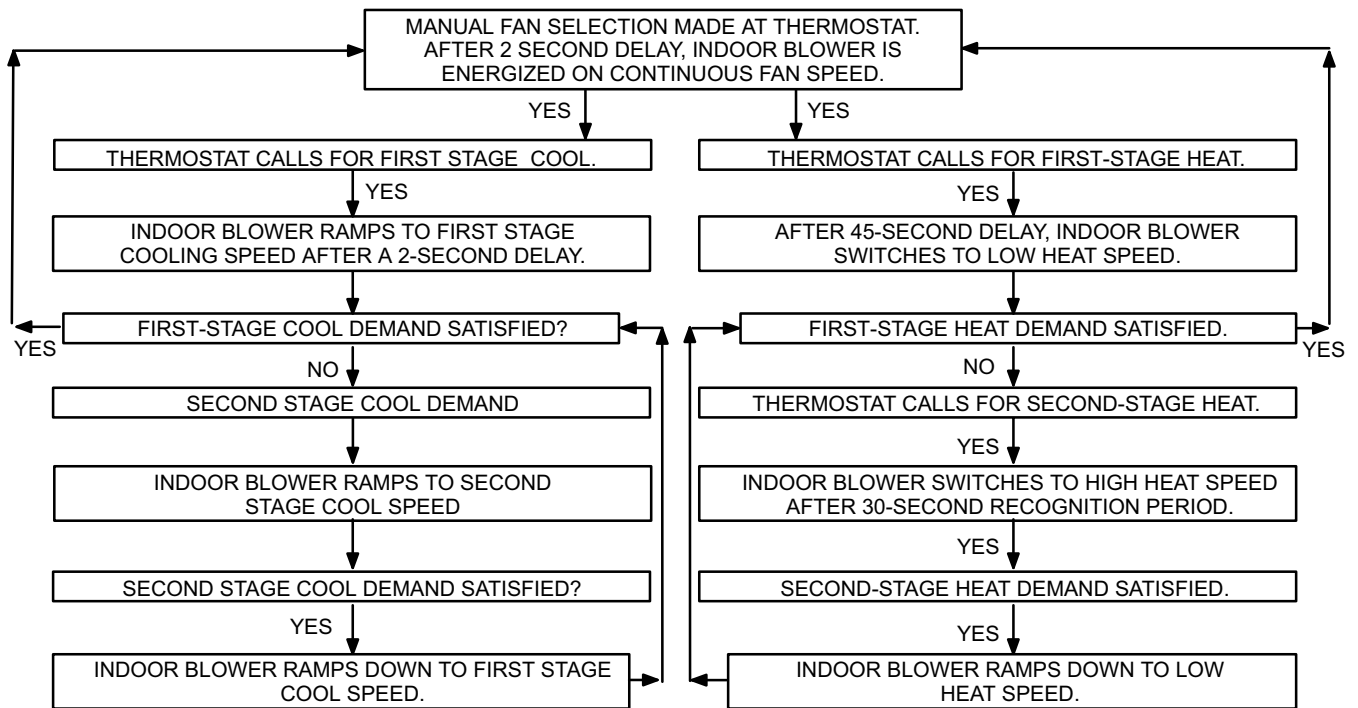

VIII-Field Wiring & Jumper Settings

A-SureLight Boards 18M99 and 49M59

Thermostat	Jumper Settings (See figure 4)				Wiring Connections
	E20	W915	W914	W951	
1 Heat / 1 Cool <i>NOTE - Use dip switch 3 to set second-stage heat ON delay.</i> <i>ON-10 minutes.</i> <i>OFF-15 minutes.</i>	SINGLE	Intact	Intact	Intact	
51M26 SignatureStat <i>NOTE - Use dip switch 3 to set second-stage heat ON delay.</i> <i>ON-10 minutes.</i> <i>OFF-15 minutes.</i>	SINGLE	Intact	Cut	Intact	
1 Heat / 1 Cool with CCB1 <i>NOTE - Use dip switch 3 to set second-stage heat ON delay.</i> <i>ON-10 minutes.</i> <i>OFF-15 minutes.</i>	SINGLE	Intact	Cut	Intact	
1 Heat / 2 Cool <i>NOTE - Use dip switch 3 to set second-stage heat ON delay.</i> <i>ON-10 minutes.</i> <i>OFF-15 minutes.</i>	SINGLE	Cut	Intact	Intact	

Thermostat	Jumper Settings (See figure 4)				Wiring Connections
	E20	W915	W914	W951	
1 Heat / 2 Cool with CCB1 <i>NOTE - Use dip switch 3 to set second-stage heat ON delay. ON-10 minutes. OFF-15 minutes.</i>	SINGLE	Cut	Cut	Intact	
2 Heat / 2 Cool	TWO	Cut	Intact	Intact	
51M27 SignatureStat	TWO	Cut	Cut	Intact	
2 Heat / 2 Cool with CCB1	TWO	Cut	Cut	Intact	

Thermostat	Jumper Settings (See figure 4)				Wiring Connections
	E20	W915	W914	W951	
2 Heat / 1 Cool	TWO	Intact	Intact	Intact	<p>S1 T'STAT CONTROL TERM. STRIP OUTDOOR UNIT</p> <p>DS</p> <p>W2 --- W2</p> <p>W1 --- W1</p> <p>R --- R --- R (HSXB15 (LSOM))</p> <p>G --- G</p> <p>C --- C --- C</p> <p>Y2</p> <p>Y --- Y1 --- Y1</p> <p>O</p>
FM21 Heat Pump / 1 Cool	SINGLE	Intact	Intact	Cut	<p>CONTROL TERM. STRIP FM21</p> <p>DS</p> <p>W2</p> <p>W1 --- W1</p> <p>R --- R</p> <p>G --- G</p> <p>C --- C</p> <p>Y2</p> <p>Y1</p> <p>O</p> <p>75VA, 24V TRANSFORMER-</p> <p><i>*Disconnect existing furnace transformer and replace with 75VA, 24V transformer if defrost option to be used.</i></p> <p><i>NOTE - Wiring connections to outdoor unit and thermostat made at FM21 control board per FM21 instructions.</i></p> <p><i>NOTE - Remove Y1/Y2 jumper for two-stage cooling.</i></p>

B-SureLight Board 100870

Thermostat	Jumper Settings (See figure 5)				Wiring Connections
	DIP Switch 1	W915 Two-Stage Cooling	W914 Dehumidification or Harmony III	W951 Heat Pumps	
1Heat / 1 Cool <i>NOTE - Use DIP switch 2 to set second-stage heat ON delay. OFF-10 minutes. ON-15 minutes.</i>	ON	Intact	Intact	Intact	
1 Heat / 2 Cool <i>NOTE - Use DIP switch 2 to set second-stage heat ON delay. OFF-10 minutes. ON-15 minutes.</i>	ON	Cut	Intact	Intact	
1 Heat / 2 Cool with t'stat with humidity control <i>NOTE - Use DIP switch 2 to set second-stage heat ON delay. OFF-10 minutes. ON-15 minutes.</i>	ON	Cut	Cut	Intact	

Thermostat	Jumper Settings (See figure 5)			Wiring Connections	
	DIP Switch 1	W915 Two-Stage Cooling	W914 Dehumidification or Harmony III		W951 Heat Pumps
2 Heat / 2 Cool	OFF	Cut	Intact	Intact	
2 Heat / 2 Cool with t'stat with humidity control	OFF	Cut	Cut	Intact	
2 Heat / 1 Cool	OFF	Intact	Intact	Intact	

IX- Troubleshooting

Two Stage Variable Speed Control Boards 18M99 & 49M59

UPON INITIAL POWER UP, REMOVE ALL THERMOSTAT DEMANDS TO THE UNIT

PROBLEM: 1 UNIT FAILS TO OPERATE IN THE COOLING, HEATING, OR CONTINUOUS FAN MODE		
Condition	Possible Cause	Corrective Action / Comments
<p>1.1</p> <p>- Both diagnostic lights fail to light up.</p> <p>LED#1-Off LED#2-Off</p>	<p>1.1.1</p> <p>Main voltage 120V not supplied to unit.</p>	<p>ACTION 1 - Check 120V main voltage. Determine cause of main power failure.</p>
	<p>1.1.2</p> <p>Miswiring of furnace or improper connections.</p>	<p>ACTION 1 - Check for correct wiring of 120V to power make up box and transformer. ACTION 2 - Check 24V wiring to control board.</p>
	<p>1.1.3</p> <p>Circuit breaker tripped or fails to close.</p>	<p>ACTION 1 - Replace circuit breaker if it is reset but does not have continuity. ACTION 2 - If circuit breaker still trips, check for short.</p>
	<p>1.1.4</p> <p>Door interlock switch failure.</p>	<p>ACTION 1 - Check that door switch is activated when door is closed. ACTION 2 - Check wire connections to switch, replace loose connectors. ACTION 3 - Check continuity of switch in closed position. Replace if defective.</p>
	<p>1.1.5</p> <p>Transformer Failure.</p>	<p>ACTION 1 - Check that transformer output is 24V. Replace if defective.</p>
	<p>1.1.6</p> <p>Failed control board.</p>	<p>ACTION 1 - If all the above items have been checked, replace board.</p>
<p>1.2</p> <p>- Diagnostic lights flash the reverse polarity code.</p> <p>LED#1-Fast Flash, LED#2-Slow Flash.</p>	<p>1.2.1</p> <p>120V main power polarity reversed.</p>	<p>ACTION 1 - Check the 120V has line and neutral correctly input into control. ACTION 2 - Reverse the line and neutral at the 120V field connection.</p>
<p>1.3</p> <p>- Diagnostic lights flash the improper main ground.</p> <p>LED#1-Alternating Fast Flash LED#2-Alternating Fast Flash</p>	<p>1.3.1</p> <p>Improper ground to the unit.</p>	<p>ACTION 1 - Check that the unit is properly ground. ACTION 2 - Install a proper main ground to the unit</p>
	<p>1.3.2</p> <p>Open ignitor circuit.</p>	<p>ACTION 1 - Check for correct wiring and loose connections in the ignitor circuit. Check multi-plug connections for correct installation.</p>
	<p>1.3.3</p> <p>Broken or failed ignitor.</p>	<p>ACTION 1 - Unplug ignitor and read resistance across ignitor. If resistance does not read between 10.9 and 19.7 ohms, replace the ignitor.</p>
	<p>1.3.4</p> <p>Line voltage is below 75V.</p>	<p>ACTION 1 - Check that the line voltage is above 75V. Determine cause of voltage drop and supply correct voltage to the control.</p>

PROBLEM 2: UNIT FAILS TO FIRE IN THE HEATING MODE, COMBUSTION AIR BLOWER DOES NOT ENERGIZE

Condition	Possible Cause	Corrective Action / Comments
<p align="center">2.1</p> <ul style="list-style-type: none"> - Unit operates with a cooling or continuous fan demand. - Combustion air inducer will not start with a Heating demand. - Diagnostic lights flash the limit failure mode. <p>LED#1-Slow Flash, LED#2-On</p>	<p>2.1.1</p> Primary Limit or secondary limit (if equipped) or rollout switch open.	<p>ACTION 1 - Check continuity across switch(es). Switches reset automatically upon cool down. Rollout switch must be reset manually.</p> <p>ACTION 2 - Check for restrictions on blower inlet air (including filter) and outlet air. Determine cause for limit activation before placing unit back in operation.</p>
	<p>2.1.2</p> Miswiring of furnace or improper connections at limit switch(es).	<p>ACTION 1 - Check for correct wiring and loose connections. Correct wiring and/or replace any loose connections.</p>
<p align="center">2.2</p> <ul style="list-style-type: none"> - Unit operates with a cooling and continuous fan demand. - Combustion air inducer will not start with a Heating demand. - Diagnostic lights flash the pressure switch failure code. <p>LED#1-Off, LED#2-Slow Flash</p>	<p>2.2.1</p> Miswiring of furnace or improper connections to combustion air inducer.	<p>ACTION 1 - Check for correct wiring and loose connections. Correct wiring and/or replace any loose connections.</p>
	<p>2.2.2</p> Prove switch stuck closed.	<p>ACTION 1 - Check that the prove switch is open without the combustion air inducer operating. Replace if defective.</p>

PROBLEM 3: UNIT FAILS TO FIRE IN THE HEATING MODE, COMBUSTION AIR INDUCER DOES NOT ENERGIZE

Condition	Possible Cause	Corrective Action/Comments
<p align="center">3.3</p> <ul style="list-style-type: none"> - Unit operates with a cooling and continuous fan demand. - Combustion air inducer will not start with a Heating demand. - Diagnostic lights flash the pressure switch failure code 2.5 minutes after heating demand. <p>LED#1-Off, LED#2-Slow Flash</p>	<p>3.3.1</p> Miswiring of furnace or improper connections to combustion air inducer.	<p>ACTION 1 - Check for correct wiring and loose connections. Correct wiring and/or replace any loose connections.</p>
	<p>3.3.2</p> Combustion air inducer failure.	<p>ACTION 1 - If there is 120V to combustion air inducer and it does not operate, replace combustion air inducer.</p>

PROBLEM 4: UNIT FAILS TO FIRE IN THE HEATING MODE, COMBUSTION AIR INDUCER ENERGIZES, IGNITOR IS NOT ENERGIZED.

Condition	Possible Cause	Corrective Action/Comments
<p align="center">4.1</p> <ul style="list-style-type: none"> - Unit operates with a cooling and continuous fan demand. - Combustion air inducer energizes with a heating demand. - Diagnostic lights flash the pressure switch failure code 2.5 minutes after heating demand. <p>LED#1-Off LED#2-Slow Flash</p>	<p align="center">4.1.1</p> <p>Prove switch does not close due to incorrect routing of the pressure switch line.</p>	<p>ACTION 1 - Check that the prove switch line is correctly routed. Correctly route prove switch line.</p>
	<p align="center">4.1.2</p> <p>Prove switch does not close due to obstructions in the pressure switch line.</p>	<p>ACTION 1 - Remove any obstructions from the the prove switch line and/or taps.</p>
	<p align="center">4.1.3</p> <p>Prove switch line damaged</p>	<p>ACTION 1 - Check prove switch line for leaks. Replace broken line if required.</p>
	<p align="center">4.1.4</p> <p>Condensate in prove switch line.</p>	<p>ACTION 1 - Check prove switch line for condensate. Remove condensate from line.</p>
	<p align="center">4.1.5</p> <p>Prove switch does not close due to a low differential pressure across the prove switch.</p>	<p>ACTION 1 - Check the differential pressure across the prove switch. This pressure should exceed the set point listed on the switch. ACTION 2 - Check for restricted inlet vent. Remove all blockage. ACTION 3 - Check for proper vent sizing and run length. See installation instructions.</p>
	<p align="center">4.1.6</p> <p>Wrong prove switch installed in the unit, or prove switch is out of calibration.</p>	<p>ACTION 1 - Check that the correct prove switch is installed in the unit. Replace prove switch if necessary.</p>
	<p align="center">4.1.7</p> <p>Miswiring of furnace or improper connections at prove switch.</p>	<p>ACTION 1 - Check for correct wiring and loose connections. Correct wiring and/or replace any loose connections.</p>
	<p align="center">4.1.8</p> <p>Prove switch failure.</p>	<p>ACTION 1 - If all the above modes of failure have been checked, the prove switch may have failed. Replace prove switch and determine if unit will operate.</p>

PROBLEM 5: UNIT FAILS TO FIRE IN THE HEATING MODE, COMBUSTION AIR BLOWER ENERGIZES, IGNITOR IS ENERGIZED.

Condition	Possible Cause	Corrective Action/Comments
<p align="center">5.1</p> <ul style="list-style-type: none"> - Unit operates with a cooling and continuous fan demand. - Combustion air inducer energizes with Heating demand. - Ignitor is energized but unit fails to light. <p>LED#1-Alternating Slow Flash LED#2-Alternating Slow Flash</p>	<p>5.1.1</p> <p>Check that gas is being supplied to the unit.</p>	<p>ACTION 1 - Check line pressure at the gas valve. Pressure should not exceed 13" WC for both natural and propane. Line pressure should read a minimum 4.5" WC for natural and 8.0"WC for propane.</p>
	<p>5.1.2</p> <p>Miswiring of gas valve or loose connections at multi-pin control amp plugs or valve.</p>	<p>ACTION 1 - Check for correct wiring and loose connections. Correct wiring and/or replace any loose connections.</p>
	<p>5.1.3</p> <p>Defective gas valve or ignition control.</p>	<p>ACTION 1 - Check that 24V is supplied to the gas valve approximately 35 seconds after heat demand is initiated. ACTION 2 - Replace the valve if 24V is supplied but valve does not open. ACTION 3 - Replace the control board if 24V is not supplied to valve.</p>

PROBLEM 6: BURNERS LIGHT WITH A HEATING DEMAND BUT UNIT SHUTS DOWN PREMATURELY

Condition	Possible Cause	Corrective Action/Comments
<p align="center">6.1</p> <ul style="list-style-type: none"> - Burners fire with a heating demand. - Burners light but unit shuts off prior to satisfying T-stat demand. - Diagnostic lights flash the pressure switch code. <p>LED#1-Off LED#2-Slow Flash</p>	<p>6.1.1</p> <p>Low pressure differential at the prove switch.</p>	<p>ACTION 1 - Check for restricted exhaust vent. Remove all blockage. ACTION 2: Check for proper vent sizing. See installation instructions.</p>
	<p>6.2.1</p> <p>Sensor or sense wire is improperly installed.</p>	<p>ACTION 1 - Check that sensor is properly located and that the sense wire is properly attached to both the sensor and the control.</p>
	<p>6.2.2</p> <p>Sensor or sense wire is broken.</p>	<p>ACTION 1 - Check for a broken sensor. ACTION 2 - Test continuity across the sense wire. If wire or sensor are damaged replace the component.</p>
	<p>6.2.3</p> <p>Sensor or sensor wire is grounded to the unit.</p>	<p>ACTION 1 - Check for resistance between the sensor rod and the unit ground. ACTION 2 - Check for resistance between the sensor wire and the unit ground. ACTION 3 - Correct any shorts found in circuit.</p>
<p>LED#1-Alternating Slow Flash LED#2-Alternating Slow Flash</p>	<p>6.2.4</p> <p>Control does not sense flame.</p>	<p>ACTION 1 - Check the microamp signal from the burner flame. If the microamp signal is below normal microamps, check the sense rod for proper location or contamination. ACTION 2 - Replace, clean, or relocate flame sense rod. If rod is to be cleaned, use steel wool or replace sensor. DO NOT CLEAN ROD WITH SAND PAPER. SAND PAPER WILL CONTRIBUTE TO THE CONTAMINATION PROBLEM. NOTE: Do not attempt to bend sense rod. ACTION 3 - Check that there is proper ground to burner box. Repair as necessary.</p>

**PROBLEM 6: BURNERS LIGHT WITH HEATING DEMAND BUT UNIT SHUTS DOWN
PREMATURELY (CONT.)**

Condition	Possible Cause	Corrective Action/Comments
<p align="center">6.3</p> <ul style="list-style-type: none"> - Combustion air inducer energizes with a heating demand. - Burners light. - Roll-out switch trips during the heating demand. - Diagnostic lights flash limit / roll-out switch failure. <p>LED#1-Slow Flash LED#2-On</p>	<p align="center">6.3.1</p> <p align="center">Unit is firing above 100% of the nameplate input.</p>	<p>ACTION 1 - Check that the manifold pressure matches value listed on nameplate. See installation instructions for proper procedure. ACTION 2 - Verify that the installed orifice size match the size listed on the nameplate or installation instructions. ACTION 3 - Check the input rate to verify rate matches value listed on nameplate.</p>
	<p align="center">6.3.2</p> <p align="center">Gas orifices leak at the manifold connection.</p>	<p>ACTION 1 - Tighten orifice until leak is sealed. NOTE: Be careful not to strip orifice threads. ACTION 2 - Check for gas leakage at the threaded orifice connection. Use approved method for leak detection (see unit instructions).</p>
	<p align="center">6.3.3</p> <p align="center">Insufficient flow through the heat exchanger caused by a sooted or restricted heat exchanger.</p>	<p>ACTION 1 - Check for sooting deposits or other restrictions in the heat exchanger assembly. Clean assembly as outlined in instruction manual. ACTION 2 - Check for proper combustion. See IV-Heating System Service Checks section G-.</p>
	<p align="center">6.3.4</p> <p align="center">Burners are not properly located in the burner box.</p>	<p>ACTION 1 - Check that the burners are firing into the center of the heat exchanger openings. Correct the location of the burners if necessary.</p>
	<p align="center">6.3.5</p> <p align="center">Poor Venting</p>	<p>ACTION 1 -Check vent pipe and remove any obstructions ACTION 2 - Check for correct exhaust vent installation. See instructions</p>
	<p align="center">6.3.6</p> <p align="center">Improper burner cross-overs</p>	<p>ACTION 1 - Remove burner and inspect the cross-overs for burrs, or any restriction or if crossover is warped. Remove restriction or replace burners.</p>
<p align="center">6.4</p> <ul style="list-style-type: none"> - Combustion air inducer energizes with a heating demand. - Burners light roughly and the unit fails to stay lit. - Diagnostic lights flash watchguard flame failure. <p>LED#1-Alternating Slow Flash LED#2-Alternating Slow Flash</p>	<p align="center">6.4.1</p> <p align="center">Poor Venting</p>	<p>ACTION 1 -Check vent pipe and remove any obstructions ACTION 2 - Check for correct exhaust vent installation. See instructions</p>
	<p align="center">6.4.2</p> <p align="center">Improper burner cross-overs</p>	<p>ACTION 1 - Remove burner and inspect the cross-overs for burrs, or any restriction or if crossover is warped. Remove restriction or replace burners.</p>
	<p align="center">6.4.3</p> <p align="center">Burrs in gas orifices</p>	<p>ACTION 1 - Remove gas orifices and inspect. Remove any burrs that are present or replace orifice.</p>

PROBLEM 6: BURNERS LIGHT WITH HEATING DEMAND BUT UNIT SHUTS DOWN PREMATURELY (CONT.)

<p align="center">6.5</p> <ul style="list-style-type: none"> - Combustion air inducer energizes with a heating demand. - Burners light. - Diagnostic lights flash watch guard flame failure. - NOTE" Unit might go into 60 minute Watchguard mode depending on intermittent nature of sensor signal. <p>LED#1-Alternating Slow Flash LED#2-Alternating Slow Flash</p>	<p align="center">6.5.1</p> <p>Loose sensor wire connection causes intermittent loss of flame signal.</p>	<p>ACTION 1 - Check that the sensor is properly located.</p> <p>ACTION 2 - Check that the sense wire is properly attached to both the sensor and the control. Pay extra attention to the pin connectors.</p>
	<p align="center">6.5.2</p> <p>Poor ground to burner box</p>	<p>ACTION 1 - Check for proper ground and repair as necessary.</p>

PROBLEM 7: CONTROL SIGNALS LOW FLAME SENSE DURING HEATING MODE

Condition	Possible Cause	Corrective Action/Comments
<p align="center">7.0</p> <ul style="list-style-type: none"> - Unit operates correctly but the diagnostic lights flash low flame sense code. <p>LED#1-Slow Flash LED#2-Fast Flash</p>	<p align="center">7.1.1</p> <p>Sense rod is improperly located on the burner.</p>	<p>ACTION 1 - Check the sense rod for proper location on the burner. Properly locate the sense rod or replace if rod cannot be located correctly.</p>
	<p align="center">7.1.2</p> <p>Sense rod is contaminated.</p>	<p>ACTION 1 - Check sense rod for contamination or coated surface. Clean the sense rod with steel wool or replace sensor. DO NOT USE SAND PAPER TO CLEAN ROD. SAND PAPER WILL CONTRIBUTE TO THE CONTAMINATION PROBLEM.</p>

PROBLEM 8: INDOOR BLOWER FAILS TO OPERATE IN COOLING, HEATING, OR CONTINUOUS FAN MODE

Condition	Possible Cause	Corrective Action/Comments
<p align="center">8.0</p> <ul style="list-style-type: none"> - Indoor blower fails to operate in continuous fan, cooling, or heating mode. 	<p align="center">8.1.1</p> <p>Miswiring of furnace or improper connections at control or indoor blower motor.</p>	<p>ACTION 1 - Correct wiring and/or replace any loose connections. Check for correct wiring and loose connections.</p>
	<p align="center">8.1.2</p> <p>120V is not being supplied to the indoor air blower or blower motor failure.</p>	<p>ACTION 1 - Check for 120V at the various calls for indoor blower by energizing "Y", "G", and "W" individually on the low voltage terminal strip. Note that when "W" is energized, the blower is delayed 45 seconds. If there is 120V to each motor tap but the blower does not operate, replace the motor.</p>
	<p align="center">8.1.3</p> <p>Defective control board</p>	<p>ACTION 1 - If there is not 120V when "Y", "G", or "W" is energized, replace the control.</p>

Two Stage Variable Speed Control Board 100870

UPON INITIAL POWER UP, REMOVE ALL THERMOSTAT DEMANDS TO THE UNIT

PROBLEM: 1 UNIT FAILS TO OPERATE IN THE COOLING, HEATING, OR CONTINUOUS FAN MODE		
Flash Code LED X + Y	Possible Cause	Corrective Action / Comments
<p>1.1</p> <p>- Diagnostic lights fail to light up.</p> <p>LED OFF</p>	<p>1.1.1</p> <p>Main voltage 120V not supplied to unit.</p>	<p>ACTION 1 - Check 120V main voltage. Determine cause of main power failure.</p>
	<p>1.1.2</p> <p>Miswiring of furnace or improper connections.</p>	<p>ACTION 1 - Check for correct wiring of 120V to power make up box and transformer. ACTION 2 - Check 24V wiring to control board.</p>
	<p>1.1.3</p> <p>Circuit breaker tripped or fails to close.</p>	<p>ACTION 1 - Replace circuit breaker if it is reset but does not have continuity. ACTION 2 - If circuit breaker still trips, check for short.</p>
	<p>1.1.4</p> <p>Door interlock switch failure.</p>	<p>ACTION 1 - Check that door switch is activated when door is closed. ACTION 2 - Check wire connections to switch, replace loose connectors. ACTION 3 - Check continuity of switch in closed position. Replace if defective.</p>
	<p>1.1.5</p> <p>Transformer Failure.</p>	<p>ACTION 1 - Check that transformer output is 24V. Replace if defective.</p>
	<p>1.1.6</p> <p>Failed control board.</p>	<p>ACTION 1 - If all the above items have been checked, replace board.</p>
<p>1.2</p> <p>Diagnostic light flashes the reverse polarity code.</p> <p>LED 5 + 4</p>	<p>1.2.1</p> <p>120V main power polarity reversed.</p>	<p>ACTION 1 - Check the 120V has line and neutral correctly input into control. ACTION 2 - Reverse the line and neutral at the 120V field connection.</p>
<p>1.3</p> <p>- Diagnostic light flash the improper main ground.</p> <p>LED 5 + 3</p>	<p>1.3.1</p> <p>Improper ground to the unit.</p>	<p>ACTION 1 - Check that the unit is properly ground. ACTION 2 - Install a proper main ground to the unit</p>
<p>1.4</p> <p>- Diagnostic light flashes ignitor circuit fault.</p> <p>LED 4 + 7</p>	<p>1.4.1</p> <p>Open ignitor circuit.</p>	<p>ACTION 1 - Check for correct wiring and loose connections in the ignitor circuit. Check multi-plug connections for correct installation.</p>
	<p>1.4.2</p> <p>Broken or failed ignitor.</p>	<p>ACTION 1 - Unplug ignitor and read resistance across ignitor. If resistance does not read between 25 and 47 ohms, replace the ignitor.</p>
<p>1.5</p> <p>- Diagnostic light flashes low line voltage</p> <p>LED 4 + 8</p>	<p>1.5.1</p> <p>Line voltage is below 90V.</p>	<p>ACTION 1 - Check that the line voltage is above 90V. Determine cause of voltage drop and supply correct voltage to the control.</p>

PROBLEM 2: UNIT FAILS TO FIRE IN THE HEATING MODE, COMBUSTION AIR BLOWER DOES NOT ENERGIZE

Flash Code LED X + Y	Possible Cause	Corrective Action / Comments
<p align="center">2.1</p> <p>Unit operates with a cooling or continuous fan demand. Combustion air inducer will not start with a Heating demand. Diagnostic lights flash the limit failure mode.</p> <p align="center">LED 3 + 1</p>	<p align="center">2.1.1</p> <p>Primary Limit or secondary limit (if equipped) open.</p>	<p>ACTION 1 - Check continuity across switch(es). Switches reset automatically upon cool down.</p> <p>ACTION 2 - Check for restrictions on blower inlet air (including filter) and outlet air. Determine cause for limit activation before placing unit back in operation.</p>
	<p align="center">2.1.2</p> <p>Miswiring of furnace or improper connections at limit switch(es).</p>	<p>ACTION 1 - Check for correct wiring and loose connections. Correct wiring and/or replace any loose connections.</p>
<p align="center">2.2</p> <p>Unit operates with a cooling and continuous fan demand. Combustion air inducer will not start with a Heating demand. Diagnostic lights flash the pressure switch failure code.</p> <p align="center">LED 2 +4</p>	<p align="center">2.2.1</p> <p>Miswiring of furnace or improper connections to combustion air inducer.</p>	<p>ACTION 1 - Check for correct wiring and loose connections. Correct wiring and/or replace any loose connections.</p>
	<p align="center">2.2.2</p> <p>Prove switch stuck closed.</p>	<p>ACTION 1 - Check that the prove switch is open without the combustion air inducer operating. Replace if defective.</p>
<p align="center">2.3</p> <p>Unit operates with a cooling or continuous fan demand. Combustion air inducer will not start with a Heating demand. Diagnostic lights flash the open rollout failure mode.</p> <p align="center">LED 5 + 1</p>	<p align="center">2.3.1</p> <p>Rollout Switch Open.</p>	<p>ACTION 1 - Check continuity across rollout switches. Rollout switches must be manually reset.</p> <p>ACTION 2 - Look for restrictions in vent pipe or combustion air inlet or heat exchanger. Determine cause before placing unit in operation.</p>

PROBLEM 3: UNIT FAILS TO FIRE IN THE HEATING MODE, COMBUSTION AIR INDUCER DOES NOT ENERGIZE

Condition	Possible Cause	Corrective Action/Comments
<p align="center">3.3</p> <p>Unit operates with a cooling and continuous fan demand. Combustion air inducer will not start with a Heating demand. Diagnostic lights flash the pressure switch failure code 2.5 minutes after heating demand.</p> <p align="center">LED 2 + 3</p>	<p align="center">3.3.1</p> <p>Miswiring of furnace or improper connections to combustion air inducer.</p>	<p>ACTION 1 - Check for correct wiring and loose connections. Correct wiring and/or replace any loose connections.</p>
	<p align="center">3.3.2</p> <p>Combustion air inducer failure.</p>	<p>ACTION 1 - If there is 120V to combustion air inducer and it does not operate, replace combustion air inducer.</p>

PROBLEM 4: UNIT FAILS TO FIRE IN THE HEATING MODE, COMBUSTION AIR INDUCER ENERGIZES, IGNITOR IS NOT ENERGIZED.

Flash Code LED X + Y	Possible Cause	Corrective Action/Comments
<p align="center">4.1</p> <ul style="list-style-type: none"> - Unit operates with a cooling and continuous fan demand. - Combustion air inducer energizes with a heating demand. - Diagnostic lights flash the pressure switch failure code 2.5 minutes after heating demand. <p align="center">LED 2 + 3</p>	<p align="center">4.1.1</p> <p>Prove switch does not close due to obstruction in vent pipe.</p>	<p>ACTION 1 - Check for restricted vent. Remove all blockage. ACTION 2: Check for proper vent sizing. See installation instructions.</p>
	<p align="center">4.1.2</p> <p>Prove switch does not close due to incorrect routing of the prove switch line.</p>	<p>ACTION 1 - Check that the prove switch line is correctly routed. Correctly route prove switch line.</p>
	<p align="center">4.1.3</p> <p>Prove switch does not close due to obstructions in the prove switch line.</p>	<p>ACTION 1 - Remove any obstructions from the the prove switch line and/or taps.</p>
	<p align="center">4.1.4</p> <p>Prove switch line damaged</p>	<p>ACTION 1 - Check prove switch line for leaks. Replace broken line if required.</p>
	<p align="center">4.1.5</p> <p>Condensate in prove switch line.</p>	<p>ACTION 1 - Check prove switch line for condensate. Remove condensate from line.</p>
	<p align="center">4.1.6</p> <p>Prove switch does not close due to a low differential pressure across the prove switch.</p>	<p>ACTION 1 - Check the differential pressure across the prove switch. This pressure should exceed the set point listed on the switch. ACTION 2 - Check for restricted inlet vent. Remove all blockage. ACTION 3 - Check for proper vent sizing and run length. See installation instructions.</p>
	<p align="center">4.1.7</p> <p>Wrong prove switch installed in the unit, or prove switch is out of calibration.</p>	<p>ACTION 1 - Check that the correct prove switch is installed in the unit. Replace prove switch if necessary.</p>
	<p align="center">4.1.8</p> <p>Miswiring of furnace or improper connections at prove switch.</p>	<p>ACTION 1 - Check for correct wiring and loose connections. Correct wiring and/or replace any loose connections.</p>
	<p align="center">4.1.9</p> <p>Prove switch failure.</p>	<p>ACTION 1 - If all the above modes of failure have been checked, the prove switch may have failed. Replace prove switch and determine if unit will operate.</p>

PROBLEM 5: UNIT FIRES ON LOW FIRE, FAILS TO GO TO HIGH FIRE OPERATION

Flash Code LED X + Y	Possible Cause	Corrective Action/Comments
<p>5.1</p> <ul style="list-style-type: none"> - Unit lights normally during low fire - Call for high fire inducer switches to high fire for 10 seconds then back to low fire. - Diagnostic lights flash the high pressure switch failure to close. <p>LED 2 + 5</p>	<p>5.1.1</p> <p>Prove switch does not close due to obstruction in vent pipe.</p>	<p>ACTION 1 - Check for restricted vent. Remove all blockage. ACTION 2: Check for proper vent sizing. See installation instructions.</p>
	<p>5.1.2</p> <p>Prove switch does not close due to incorrect routing of the prove switch line.</p>	<p>ACTION 1 - Check that the prove switch line is correctly routed. Correctly route prove switch line.</p>
	<p>5.1.3</p> <p>Prove switch does not close due to obstructions in the prove switch line.</p>	<p>ACTION 1 - Remove any obstructions from the the prove switch line and/or taps.</p>
	<p>5.1.4</p> <p>Prove switch line damaged</p>	<p>ACTION 1 - Check prove switch line for leaks. Replace broken line if required.</p>
	<p>5.1.5</p> <p>Condensate in prove switch line.</p>	<p>ACTION 1 - Check prove switch line for condensate. Remove condensate from line.</p>
	<p>5.1.6</p> <p>Prove switch does not close due to a low differential prove across the prove switch.</p>	<p>ACTION 1 - Check the differential pressure across the prove switch. This pressure should exceed the set point listed on the switch. ACTION 2 - Check for restricted inlet vent. Remove all blockage. ACTION 3 - Check for proper vent sizing and run length. See installation instructions.</p>
	<p>5.1.7</p> <p>Wrong prove switch installed in the unit, or prove switch is out of calibration.</p>	<p>ACTION 1 - Check that the correct prove switch is installed in the unit. Replace prove switch if necessary.</p>
	<p>5.1.8</p> <p>Miswiring of furnace or improper connections at prove switch.</p>	<p>ACTION 1 - Check for correct wiring and loose connections. Correct wiring and/or replace any loose connections.</p>
	<p>5.1.9</p> <p>Prove switch failure.</p>	<p>ACTION 1 - If all the above modes of failure have been checked, the prove switch may have failed. Replace prove switch and determine if unit will operate.</p>

PROBLEM 6: UNIT FAILS TO FIRE IN THE HEATING MODE, COMBUSTION AIR BLOWER ENERGIZES, IGNITOR IS ENERGIZED.

Flash Code LED X + Y	Possible Cause	Corrective Action/Comments
6.1 Unit operates with a cooling and continuous fan demand. Combustion air inducer energizes with Heating demand. Ignitor is energized but unit fails to light.	6.1.1 Check that gas is being supplied to the unit.	ACTION 1 - Check line pressure at the gas valve. Pressure should not exceed 13" WC for both natural and propane. Line pressure should read a minimum 4.5" WC for natural and 8.0"WC for propane.
	6.1.2 Miswiring of gas valve or loose connections at multi-pin control amp plugs or valve.	ACTION 1 - Check for correct wiring and loose connections. Correct wiring and/or replace any loose connections.
LED 4 + 1	6.1.3 Defective gas valve or ignition control.	ACTION 1 - Check that 24V is supplied to the gas valve approximately 35 seconds after heat demand is initiated. ACTION 2 - Replace the valve if 24V is supplied but valve does not open. ACTION 3 - Replace the control board if 24V is not supplied to valve.

PROBLEM 7: BURNERS LIGHT WITH A HEATING DEMAND BUT UNIT SHUTS DOWN PREMATURELY

Flash Code LED X + Y	Possible Cause	Corrective Action/Comments
7.1 Burners fire with a heating demand. Burners light but unit shuts off prior to satisfying T-stat demand. Diagnostic lights flash the prove switch code.	7.1.1 Low pressure differential at the prove switch.	ACTION 1 - Check for restricted exhaust vent. Remove all blockage. ACTION 2: Check for proper vent sizing. See installation instructions.
LED 2 + 7		
7.2 Combustion air inducer energizes with a heating demand. Burners light but fail to stay lit. After 5 tries the control diagnostics flash the watchguard burners failed to ignite code.	7.2.1 Sensor or sense wire is improperly installed.	ACTION 1 - Check that sensor is properly located and that the sense wire is properly attached to both the sensor and the control.
	7.2.2 Sensor or sense wire is broken.	ACTION 1 - Check for a broken sensor. ACTION 2 - Test continuity across the sense wire. If wire or sensor are damaged replace the component.
LED 4 + 3	7.2.3 Sensor or sensor wire is grounded to the unit.	ACTION 1 - Check for resistance between the sensor rod and the unit ground. ACTION 2 - Check for resistance between the sensor wire and the unit ground. ACTION 3 - Correct any shorts found in circuit.
	7.2.4 Control does not sense flame.	ACTION 1 - Check the microamp signal from the burner flame. If the microamp signal is below normal microamps, check the sense rod for proper location or contamination. ACTION 2 - Replace, clean, or relocate flame sense rod. If rod is to be cleaned, use steel wool or replace sensor. DO NOT CLEAN ROD WITH SAND PAPER. SAND PAPER WILL CONTRIBUTE TO THE CONTAMINATION PROBLEM. NOTE: Do not attempt to bend sense rod. ACTION 3 - Check that there is proper ground to burner box. Repair as necessary.

**PROBLEM 7: BURNERS LIGHT WITH HEATING DEMAND BUT UNIT SHUTS DOWN
PREMATURELY (CONT.)**

Flash Code LED X + Y	Possible Cause	Corrective Action/Comments
<p align="center">7.3</p> <p>Combustion air inducer energizes with a heating demand. Burners light. Roll-out switch trips during the heating demand. Diagnostic lights flash roll-out switch failure.</p> <p align="center">LED 5 + 1</p>	<p align="center">7.3.1</p> <p>Unit is firing above 100% of the nameplate input.</p>	<p>ACTION 1 - Check that the manifold pressure matches value listed on nameplate. See installation instructions for proper procedure. ACTION 2 - Verify that the installed orifice size match the size listed on the nameplate or installation instructions. ACTION 3 - Check the input rate to verify rate matches value listed on nameplate.</p>
	<p align="center">7.3.2</p> <p>Gas orifices leak at the manifold connection.</p>	<p>ACTION 1 - Tighten orifice until leak is sealed. NOTE: Be careful not to strip orifice threads. ACTION 2 - Check for gas leakage at the threaded orifice connection. Use approved method for leak detection (see unit instructions).</p>
	<p align="center">7.3.3</p> <p>Insufficient flow through the heat exchanger caused by a sooted or restricted heat exchanger.</p>	<p>ACTION 1 - Check for sooting deposits or other restrictions in the heat exchanger assembly. Clean assembly as outlined in instruction manual. ACTION 2 - Check for proper combustion. See IV-Heating System Service Checks section G-.</p>
	<p align="center">7.3.4</p> <p>Burners are not properly located in the burner box.</p>	<p>ACTION 1 - Check that the burners are firing into the center of the heat exchanger openings. Correct the location of the burners if necessary.</p>
	<p align="center">7.3.5</p> <p>Poor Venting</p>	<p>ACTION 1 - Check vent pipe and remove any obstructions ACTION 2 - Check for correct exhaust vent installation. See instructions</p>
	<p align="center">7.3.6</p> <p>Improper burner cross-overs</p>	<p>ACTION 1 - Remove burner and inspect the cross-overs for burrs, or any restriction or if crossover is warped. Remove restriction or replace burners.</p>
<p align="center">7.4</p> <p>Combustion air inducer energizes with a heating demand. Burners light roughly and the unit fails to stay lit. Diagnostic lights flash watchguard flame failure.</p> <p align="center">LED 4 + 3</p>	<p align="center">7.4.1</p> <p>Poor Venting</p>	<p>ACTION 1 - Check vent pipe and remove any obstructions ACTION 2 - Check for correct exhaust vent installation. See instructions</p>
	<p align="center">7.4.2</p> <p>Improper burner cross-overs</p>	<p>ACTION 1 - Remove burner and inspect the cross-overs for burrs, or any restriction or if crossover is warped. Remove restriction or replace burners.</p>
	<p align="center">7.4.3</p> <p>Burrs in gas orifices</p>	<p>ACTION 1 - Remove gas orifices and inspect. Remove any burrs that are present or replace orifice.</p>

PROBLEM 7: BURNERS LIGHT WITH HEATING DEMAND BUT UNIT SHUTS DOWN PREMATURELY (CONT.)

Flash Code LED X + Y	Possible Cause	Corrective Action/Comments
7.5 Combustion air inducer energizes with a heating demand. - Burners light. Diagnostic lights flash watch guard flame failure. NOTE" Unit might go into 60 minute Watchguard mode depending on intermittent nature of sensor signal.	7.5.1 Loose sensor wire connection causes intermittent loss of flame signal.	ACTION 1 - Check that the sensor is properly located. ACTION 2 - Check that the sense wire is properly attached to both the sensor and the control. Pay extra attention to the pin connectors.
LED 4 + 3	7.5.2 Poor ground to burner box	ACTION 1 - Check for proper ground and repair as necessary.

PROBLEM 8: CONTROL SIGNALS LOW FLAME SENSE DURING HEATING MODE

Condition	Possible Cause	Corrective Action/Comments
8.0 Unit operates correctly but the diagnostic lights flash low flame sense code.	8.1.1 Sense rod is improperly located on the burner.	ACTION 1 - Check the sense rod for proper location on the burner. Properly locate the sense rod or replace if rod cannot be located correctly.
LED 1 + 2	8.1.2 Sense rod is contaminated.	ACTION 1 - Check sense rod for contamination or coated surface. Clean the sense rod with steel wool or replace sensor. DO NOT USE SAND PAPER TO CLEAN ROD. SAND PAPER WILL CONTRIBUTE TO THE CONTAMINATION PROBLEM.

PROBLEM 9: INDOOR BLOWER FAILS TO OPERATE IN COOLING, HEATING, OR CONTINUOUS FAN MODE

Condition	Possible Cause	Corrective Action/Comments
9.0 - Indoor blower fails to operate in continuous fan, cooling, or heating mode.	9.1.1 Miswiring of furnace or improper connections at control or indoor blower motor.	ACTION 1 - Correct wiring and/or replace any loose connections. Check for correct wiring and loose connections.
	9.1.2 120V is not being supplied to the indoor air blower or blower motor failure.	ACTION 1 - PSC MOTORS Check for 120V at the various calls for indoor blower by energizing "Y", "G", and "W" individually on the low voltage terminal strip. Note that when "W" is energized, the blower is delayed 45 seconds. If there is 120V to each motor tap but the blower does not operate, replace the motor. ACTION 1 - VARIABLE SPEED MOTORS for operation of the VSM see Page 24
	9.1.3 Defective control board	ACTION 1 - PSC MOTORS If there is not 120V when "Y", "G", or "W" is energized, replace the control.

ICM-2 WITH TWO STAGE VARIABLE SPEED CONTROL BOARD

120V to the motor must not be interrupted. All connections for check out will be from the voltage source below (battery or 24V) to plug J46, after disconnecting from blower control board.

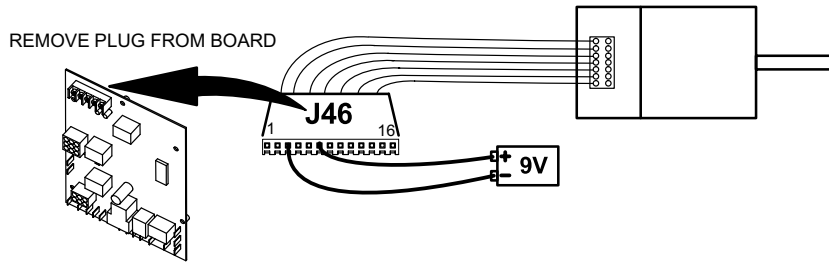

CHECK-OUT PROCEDURE USING BATTERY

An ordinary 9 volt battery with maximum DC 20volts is recommended. A 9 volt battery will last for about one day of normal operation.

LOW COOL SPEED

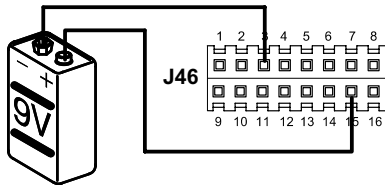

- 1 Disconnect power to unit.
- 2 Disconnect plug J46 from P46 located on the blower control board.
- 3 Connect voltage source as shown above.
- 4 Turn on power to unit. Blower should operate at low cool speed.

HIGH COOL SPEED

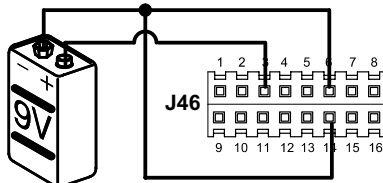

- 5 Disconnect power to unit.
- 6 Connect voltage source as shown above.
- 7 Turn on power to unit. Blower should operate at high cool speed.

LOW HEAT SPEED

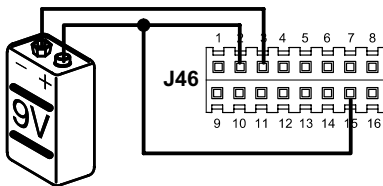

- 8 Disconnect power to unit.
- 9 Connect voltage source as shown above.
- 10 Turn on power to unit. Blower should operate at low heat speed.

HIGH HEAT SPEED

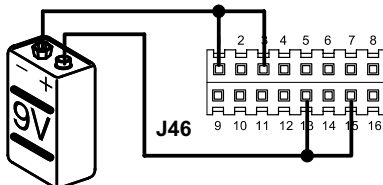

- 11 Disconnect power to unit.
- 12 Connect voltage source as shown above.
- 13 Turn on power to unit. Blower should operate at high heat speed.

CHECK-OUT PROCEDURE USING 24V SOURCE

Unit transformer T1 with a maximum AC 30 volts may be used in lieu of a battery. If transformer T1 is used, double check all wiring connections before placing unit back in operation.

LOW COOL SPEED

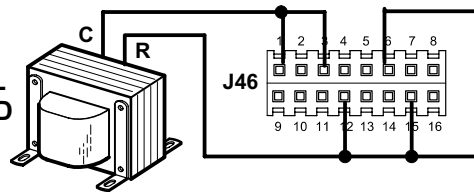

- 1 Disconnect power to unit.
- 2 Disconnect plug J46 from P46 located on the blower control board.
- 3 Connect voltage source as shown above.
- 4 Turn on power to unit. Blower should operate at low cool speed.

HIGH COOL SPEED

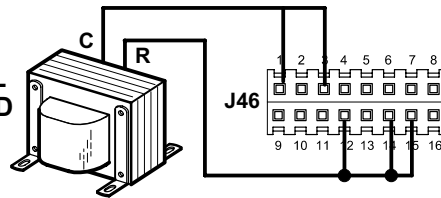

- 5 Disconnect power to unit.
- 6 Connect voltage source as shown above.
- 7 Turn on power to unit. Blower should operate at high cool speed.

LOW HEAT SPEED

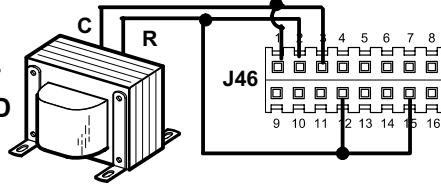

- 8 Disconnect power to unit.
- 9 Connect voltage source as shown above.
- 10 Turn on power to unit. Blower should operate at low heat speed.

HIGH HEAT SPEED

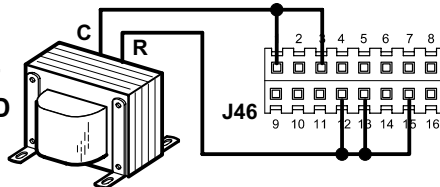

- 11 Disconnect power to unit.
- 12 Connect voltage source as shown above.
- 13 Turn on power to unit. Blower should operate at high heat speed.