

Publish Date: Jan. 29, 2021

# Emerson Educational Services



Maximize Your Investment with Well-Trained Personnel





## COURSE TYPES

“Experiential [learning] is a philosophy and methodology in which educators purposefully engage with students in direct experience and focused reflection in order to increase knowledge, develop skills, and clarify values.”

### On-site Traditional

Through our onsite training services, we provide customers a Certified Instructor, courseware literature, and all hardware associated with supporting hands-on workshops. In North America, we deliver onsite training courses sponsored through our Local Business Partners' Education Program Education Program. This allows our customers the opportunity to access our Training Courses through their local business partner.

### Virtual Learning



Emerson's Virtual Classroom delivers real-time value-based Instructor-Led Training to customers' desktops with full access to software systems. Students connect directly to classroom-based machines for the entire class! There is no travel required which means fewer expenses for our customers. Class takes place in a live online training room using a teleconference bridge.

### eLearning



Emerson eLearning offerings are professionally developed, engaging, flexible and up to date. Emerson online learning programs provide a convenient opportunity to study about our technologies and solutions at any time. Our goal is to provide our customers a competitive advantage by empowering them with the latest knowledge in a growing range of topics.

### Blended Learning



Blended Learning is a contemporary approach to training that “blends” different teaching methods and deploys them via digital and online media to maximize the effectiveness and convenience of learning. The Emerson's Blended Learning approach combines various learning methods using a variety of digital media. Blended Learning is Emerson's unique approach to delivering quality education while reducing learner time away from the facility.

## IACET Authorized Provider

---

Educational Services is an Authorized Provider of International Association for Continuing Education and Training (IACET) Continuing Education Units (CEU). IACET Authorized Provider Status Means our Organization:

- Demonstrates compliance with proven, research- based standards created in cooperation with the U.S. Department of Education
- Is dedicated to high standards for quality in continuing education and training
- Awards the IACET EDU, the hallmark for quality in continuing education and training

Educational Services is proud to have received Authorized Provider status. We look forward to the opportunity to share our training with you.

## Qualifications for Enrollment

---

Educational Services agrees to accept for training, individuals who are not competitors of Emerson Automation Solutions in the field to which the training pertains. Educational Services will provide reasonable accommodations to students who have a physical or mental impairment that substantially limits one or more major life activities, as long as the accommodation does not put undue hardship on the company.

## Course Scheduling, Locations & Pricing

---

Course schedule and locations including length, dates of each session and price are listed on the Educational Services MyCONNECT website. All prices are in U.S. dollars. For the most up to date information call or visit our website at: [www.emerson.com/education](http://www.emerson.com/education)

## Tuition

---

Methods of payment include: purchase order, acceptable credit cards include: Visa, MasterCard and American Express. All tuition is subject to change without notice. Transportation, personal expenses and most meals are the responsibility of the student.

## Cancellations & Transfers

---

If your plans or budgets change you may cancel/transfer your reservations up to 14 calendar days prior to start of the course without incurring a cancellation charge. Limited enrollment makes it necessary to charge 50% of the full tuition for cancellations/transfers received during the 14 days prior to the start of the course, and full tuition for failure to attend without cancelling. Substitutions are accepted until the first day of class.

## Arrival & Departure Time

---

Students should plan to arrive the day prior to the course starting day, as class typically begins at 8 a.m. If traveling by air, please allow sufficient time to travel to the airport and check-in when scheduling return transportation.

## Course Materials

---

All materials presented are copyrighted. Audio and video recording is prohibited and no material or portion of any school may be reproduced in any manner without prior written approval. All necessary documentation, catalogs, and literature are included in the course tuition. The training materials were developed by and for Emerson Educational Services exclusive use.

## On-Site and Local Training

---

Educational Services instructors are available to provide expert training anywhere in the world. We can conduct training tailored to meet your needs at your facility or regional and local sites. To learn more about on-site and local training contact your local Emerson service provider or call 1-800-338-8158.

## eLearning

---

Training courses are available to you on-line. You can learn at your pace and on your time. For more information please visit our web page: [www.emerson.com/education](http://www.emerson.com/education)

AMS.....	<a href="#">5</a>
Bettis.....	<a href="#">9</a>
Daniel .....	<a href="#">12</a>
DeltaV .....	<a href="#">15</a>
EnTech .....	<a href="#">34</a>
Fisher.....	<a href="#">36</a>
Machinery Health .....	<a href="#">48</a>
METCO.....	<a href="#">58</a>
Micro Motion.....	<a href="#">60</a>
Mimic .....	<a href="#">68</a>
Operational Certainty.....	<a href="#">69</a>
Ovation .....	<a href="#">73</a>
PLC.....	<a href="#">89</a>
Regulators and Relief Valves.....	<a href="#">93</a>
Remote Automation Solutions.....	<a href="#">95</a>
Rosemount .....	<a href="#">114</a>
Roxar .....	<a href="#">137</a>
RS3.....	<a href="#">141</a>
Shafer .....	<a href="#">142</a>
Syncade.....	<a href="#">143</a>
Educational Services Information.....	<a href="#">151</a>
Asia Pacific Training Center Contact Information .....	<a href="#">150</a>
Europe Training Center Contact Information .....	<a href="#">151</a>
Latin America / Middle East-Africa / Canada Training Center Contact Information.....	<a href="#">152</a>
Course Offerings Contact Information. ....	<a href="#">153</a>
Educational Services Learning Paths - DeltaV .....	<a href="#">155</a>
Educational Services Learning Paths - Fisher .....	<a href="#">165</a>
Educational Services Learning Paths - Rosemount.....	<a href="#">183</a>
Curriculum Paths .....	<a href="#">203</a>

## AMS Device Manager – 7020 CEUs - 2.1

### Overview

Completing 3-days of AMS Device Manager hands-on instructor assisted training modules and exercises, provides the quickest route to your productive use of this predictive maintenance application.

### Topics

- Viewing and Modifying Devices
- Creating a Plant Database Hierarchy and Adding Devices
- Using the Field Communicator with AMS Device Manager
- Using the AMS Device Manager Browser Functions
- Audit Trail
- Calibrating Device - Calibration Assistant
- Configuring and Monitoring System Alerts
- Installing an AMS Device Manager Server Plus Standalone
- Starting AMS Device Manager for the First Time
- Network Communication Interface Setup
- AMS Device Manager Database Management
- Installing a Distributed System
- Installing Device Types from Media
- MV Engineering Assistant SNAP-ON Application
- QuickCheck™ SNAP-ON Application
- AMS Device Manager OPC Server and the Matrikon OPC Explorer
- AMS Device Manager Web Services
- AlertTrack™ SNAP-ON Application
- Wireless SNAP-ON Application

### Audience

This course is intended for technicians and engineers who need to configure and use AMS Device Manager.

## AMS Device Manager with Rosemount HART Instruments – 7021 CEUs - 2.1

### Overview

Learn the installation, calibration, maintenance, and troubleshooting of measurement instrumentation using AMS Device Manager. This 3-day course teaches maintenance and calibration of measurement devices using AMS Device Manager software to communicate and track information. The student will learn how pressure and temperature transmitters function, are installed, and calibrated using AMS Device Manager. The course uses hands-on training, labs, and lecture to teach the student how to:

- configure and use AMS Device Manager correctly perform transmitter installation and setup procedures
- properly configure HART® transmitters
- properly calibrate transmitters
- perform basic troubleshooting-transmitters

### Topics

- Configuring and Using AMS Device Manager
- Viewing and Modifying Devices
- Creating a Plant Database Hierarchy and Adding Devices
- AMS Device Manager Browser Functions
- Audit Trail
- HART Communication
- HART Transmitters (3051C, 3144P)
- Test Equipment Selection
- Transmitter Installation and Configuration
- Transmitter Calibration
- AMS Calibration Assistant
- Intelligent Calibrators
- Transmitter Troubleshooting

### Audience

The hands-on focus is on skills required by engineers, technicians, or others that are new to the plant or instrument environment.

## AMS Device Manager with DeltaV – 7039 CEUs – 2.8

### Overview

This 4-day course is for instrumentation technicians responsible for all areas of managing and ensuring the reliability of instrumentation in the plant process including startup and commissioning, normal operations, maintenance, and troubleshooting.

### Topics

- DeltaV and PlantWeb Overview
- AMS Device Manager Overview
- FOUNDATION™ fieldbus Overview
- ValveLink™ SNAP-ON Introduction
- ValveLink™ DVC Setup
- ValveLink™ SNAP-ON Tests and Diagnostics
- HART® Overview
- PROCONEX QuickCheck SNAP-ON
- PROFIBUS Overview
- PlantWeb Alerts
- AMS Device Manager User Interface
- Setup and use of Alert Monitor in AMS Device Manager
- Device Replacement for HART, Fieldbus, and PROFIBUS Devices
- AMS Device Manager Audit Trail
- AMS Device Manager Calibration Assistant
- Smart Commissioning

### Audience

The target audience usually does following:

- Responds to work orders created to calibrate, troubleshoot, repair, service, and replace instruments and valves
- Monitors alerts to preemptively address problems prior to operators seeing a problem in the control room
- Provides loop testing & assistance with instrumentation in plant turnarounds, startups, and for project work
- Improves process availability & reduces operations and maintenance costs

### Prerequisites

Microsoft windows experience. Minimal DeltaV and AMS experience is recommended but not required. Recommended to take 7018, but not required.

### AMS Machinery Manager – Advanced - 2070 CEUs - 2.8

#### Overview

This 4-day course is the third in our series of AMS Machinery Manager courses. Its focus is on the management, modification and optimization of the existing AMS Machinery Manager database. Students will learn how to modify existing Wizard configurations, add and edit users, statistically adjust alert and fault levels, make global database changes, and many other very useful database functions. This course is based on the current mass release of the AMS Machinery Manager software. Students can call to verify if the course is appropriate to the version they are using. Wireless technology, Infrared Analysis, Motorview, Online Monitor and Oilview modules are covered in other course offerings and are not part of this course.

#### Topics

- Advanced Analysis Features in Vibration Analysis Module
- Problem Reporting
- Status-at-a-Glance Operation and Reporting
- Nspectr®
- Wizard - Reporting Techniques and Modification/Addition of Setup Information
- Austostat
- Database Utility
- Database Zip Utility
- Network Administration
- Data Locker Management

#### Audience

This course is intended for the advanced user who has already created a machinery database and has been acquiring, storing and analyzing data for six months or more. Prerequisites

#### Prerequisites

Intermediate Vibration (course 2032) or one-year vibration analysis experience are recommended. Experience with the Windows operating system is recommended.

### AMS Machinery Manager – Advanced - Virtual - 2070V CEUs - 2.8



#### Overview

This 4-day course is the third in our series of AMS Machinery Manager courses. Its focus is on the management, modification and optimization of the existing AMS Machinery Manager database. Students will learn how to modify existing Wizard configurations, add and edit users, statistically adjust alert and fault levels, make global database changes, and many other very useful database functions. This course is based on the current mass release of the AMS Machinery Manager software. Students can call to verify if the course is appropriate to the version they are using. Wireless technology, Infrared Analysis, Motorview, Online Monitor, and Oilview modules are covered in other course offerings and are not part of this course.

#### Topics

- Advanced Analysis Features in Vibration Analysis Module
- Problem Reporting
- Status-at-a-Glance Operation and Reporting
- Nspectr®
- Wizard - Reporting Techniques and Modification/Addition of Setup Information
- Austostat
- Database Utility
- Database Zip Utility
- Network Administration
- Data Locker Management

#### Audience

This course is intended for the advanced user who has already created a machinery database and has been acquiring, storing and analyzing data for six months or more.

#### Prerequisites

Intermediate Vibration (course 2032) or one-year vibration analysis experience are recommended. Experience with the Windows operating system is recommended.

### AMS Machinery Manager – Intermediate - 2074 CEUs - 2.8

#### Overview

This 4-day course teaches some of the more advanced machinery analysis techniques available in AMS Suite Machinery Health™ Manager Software. This course focuses more on analysis and reporting with the use of Vibration Analysis module, Reporting module, Exception Analysis, PEAKVUE™ technology and full version of RBMview.

This course is based on the current mass release of the AMS Machinery Manager software. Students can call to verify if the course is appropriate to the version they are using. Wireless technology, Infrared Analysis, Motorview, Online Monitor and Oilview modules are covered in other course offerings and are not part of this course.

#### Topics

- PEAKVUE™ Technology
- Vibration Analysis module
- Reporting Module
- Exception Analysis
- Nspectr
- BMview
- Data Transfer
- Route Modification

#### Prerequisites

Intro to AMS Machinery Health™ Manager (course # 2068), Basic Vibration Analysis course or 6 months vibration analysis experience are recommended.



### AMS Machinery Manager – Intermediate - Virtual - 2074V CEUs - 2.8



#### Overview

This 4-day advanced course teaches some of the more advanced machinery analysis techniques available in AMS Suite Machinery Health™ Manager Software. This course focuses more on analysis and reporting with the use of Vibration Analysis module, reporting module, Exception Analysis, PEAKVUE™ technology and full version of RBMview.

This course is based on the current mass release of the AMS Machinery Manager software. Students can call to verify if the course is appropriate to the version they are using. Wireless technology, Infrared Analysis, Motorview, Online Monitor and Oilview modules are covered in other course offerings and are not part of this course.

#### Topics

- PEAKVUE™
- Vibration Analysis module
- Reporting Module
- Exception Analysis
- Nspectr
- BMview
- Data Transfer
- Route Modification

#### Prerequisites

Intro to AMS Machinery Health™ Manager (course # 2068), Basic Vibration Analysis course or 6-months vibration analysis experience are recommended.

### AMS Machinery Manager – Introduction - 2068 CEUs - 2.8

#### Overview

In this 4-day class students learn methods of database creation and vital features of route creation such as collecting reference data, analyzer/computer communication, and the basic concepts of Analysis Parameter Sets, Alarm Limit Sets, and Fault Frequency Sets. A machinery analyzer is used to demo the process of loading routes for data collection. This course will also include a basic overview of the vibration plotting application and reporting functions.

This course is based on the current mass release of the AMS Machinery Manager software. Students can call to verify if the course is appropriate to the version they are using. Wireless technology, Infrared Analysis, Motorview, Online Monitor and Oilview modules are covered in other course offerings and are not part of this course.

#### Topics

- RBMwizard
- Database Setup
- Route management and Data transfer
- Reports
- Vibration Analysis module

#### Audience.

This course was designed for the new users of AMS Machinery Manager.

#### Prerequisites

Computer experience with the Windows operating system and some vibration analysis experience are recommended.

### AMS Machinery Manager – Introduction – Virtual - 2068V CEUs - 2.8



#### Overview

This 4-day class students learn methods of database creation and vital features of route creation such as collecting reference data, analyzer/computer communication, and the basic concepts of Analysis Parameter Sets, Alarm Limit Sets, and Fault Frequency Sets. A machinery analyzer is used to demo the process of loading routes for data collection. This course will also include a basic overview of the vibration plotting application and reporting functions.

This course is based on the current mass release of the AMS Machinery Manager software. Students can call to verify if the course is appropriate to the version they are using. Wireless technology, Infrared Analysis, Motorview, Online Monitor and Oilview modules are covered in other course offerings and are not part of this course.

#### Topics

- RBMwizard
- Database Setup
- Route management and Data transfer
- Reports
- Vibration Analysis module

#### Audience

This course was designed for the new users of AMS Machinery Manager.

#### Prerequisites

Computer experience with the Windows operating system and some vibration analysis experience are recommended.

### AMS Machinery Manager Database Optimization - 2003 CEUs - 2.8

#### Overview

This 4-day course is the fourth in our series of AMS Machinery Manager courses. This course will instruct experienced users on database optimization techniques using an existing database and enhancing it by calculating and implementing improved Analysis Parameter (AP) sets. Students will learn how to identify when an AP set needs to be adjusted and how to make the adjustments effectively. This course will also focus on updating and optimizing alarm sets. Applications will include Vibration Analysis tab, Database Setup, Database Utility, Stored Data Management and Autostat

#### Topics

- Understanding the Database
- Managing Invalid Data
- Analysis Parameter Set Review
- Manual Alarm Adjustment
- AutoStat Alarm Adjustment
- Warning Alarms

This course is based on the current mass release of the AMS Machinery Manager software. Students may call to verify if the course is appropriate to the version they are using.

#### Prerequisites

Introduction to AMS Machinery Manager (course #2068), Intermediate AMS Machinery Manager (course #2074), Advanced AMS Machinery Manager (course #2070), Intermediate Vibration (course #2032) or two-years vibration analysis experience are strongly recommended.

### AMS Machinery Manager Database Optimization – Virtual – 2003V CEUs - 2.8



#### Overview

This 4-day course is the fourth in our series of AMS Machinery Manager courses. This course will instruct experienced users on database optimization techniques using an existing database and enhancing it by calculating and implementing improved Analysis Parameter (AP) sets. Students will learn how to identify when an AP set needs to be adjusted and how to make the adjustments effectively. This course will also focus on updating and optimizing alarm sets. Applications will include Vibration Analysis tab, Database Setup, Database Utility, Stored Data Management and Autostat.

#### Topics

- Understanding the Database
- Managing Invalid Data
- Analysis Parameter Set Review
- Electric Motor Points
- Manual Alarm Adjustment
- AutoStat Alarm Adjustment
- Warning Alarms

This course is based on the current mass release of the AMS Machinery Manager software. Students may call to verify if the course is appropriate to the version they are using.

#### Prerequisites

Introduction to AMS Machinery Manager (course #2068), Intermediate AMS Machinery Manager (course #2074), Advanced AMS Machinery Manager (course #2070), Intermediate Vibration (course #2032) or two-years vibration analysis experience are strongly recommended.



### Bettis MCP-M2CP – Maintenance & Field Service – Introduction – VA111 CEUs – 1.2

#### Overview

Fundamental overview of the construction, assembly, hardware, software and configuration of Emerson's Bettis™ MCP & M2CP actuators. Students attending this program will demonstrate an ability to identify actuators, hardware, components and assemblies. All students will demonstrate the ability to setup, configure, check and verify operation of various actuator configurations using appropriate hardware or software.

#### Topics

- Identify main mechanical components and understand the function of Emerson's Bettis M2CP and MCP actuators
- Identify main components and understand function of the modular control package (MCP)
- Identify main components and understand function of the second generation modular control package (M2CP)
- Setup and Commissioning
- Identify function and main components of bevel gears and worm gears
- Introduction to DCMLink

#### Prerequisites

Students should have a minimum of one year field service experience and a working knowledge of Bettis M2CP actuators.

### Bettis TEC2 Maintenance & Field Service - Introduction - VA114 CEUs – 1.2

#### Overview

Fundamental overview of the construction, assembly, hardware, software and configuration of Emerson's Bettis Tec2000 and Tec2 actuators. Students attending this program will demonstrate an ability to identify actuators, hardware, components and assemblies. All students will demonstrate the ability to setup, configure, check and verify operation of various actuator configurations using appropriate hardware or software.

Duration: 2 Days

Who Should Attend:

Field Service Technicians

Sales Engineers

Quotation Managers

Instrumentation and Control Technicians

#### Topics

- Identify main mechanical components and understand the function of Emerson's Bettis Tec2 actuators
- Identify main components and understand function of the non-intrusive Tec2 control package.
- Setup and Commissioning
- Identify function and main components of bevel gears and worm gears
- Introduction to DCMLink

### Bettis TEC2 Maintenance & Field Service - Introduction - VA114 – Continued...

#### Prerequisites

Students should have a minimum of one-year field service experience and a working knowledge of Bettis TEC2 actuators.

### Bettis XTE3000 Maintenance & Field Service - Introduction - VA134 CEUs – 1.2

#### Overview

This course presents the fundamental aspects of Bettis XTE3000 actuators. Attendees are presented with essentials of design and operation and how they operate the valves. Basic components and assemblies are identified to aid in understanding the basic controls, applications, and mechanical operation. Each student will learn how to set travel limits, torque limits and operate an actuator on or off the valve. Model number interpretation, document relevance (Spec Sheet; Manuals; Wiring Diagrams; Outlines; Assembly Drawing) and support resources will be discussed.

#### Topics

- Identify main mechanical and electrical components
- Understand the control inputs, feedback outputs, and optional modules for the Bettis XTE3000 actuator
- Setup and Commissioning
- Status LED codes and fixes
- Configuration with AManager software
- Diagnosing and resolving error codes

#### Audience

Field Service Technicians

Sales Engineers

Quotation Managers

Instrumentation and Control Technicians

#### Prerequisites

Students should have a minimum of one-year field service experience and a working knowledge of Bettis XTE3000 actuators.

### Bettis RTS Electric Actuator Product & Service – Introduction – VA123 CEUs – 1.2

#### Overview

This 2-day course presents the fundamental aspects of RTS actuators. Attendees are presented with essentials of design and operation and how they operate the valves. Basic components and assemblies are identified to aid in understanding the basic controls, applications, and mechanical operation. Each student will learn how to set travel limits, torque limits and operate an actuator on or off the valve. Model number interpretation, document relevance (Spec Sheet; Manuals; Wiring Diagrams; Outlines; Assembly Drawing) and support resources will be discussed. How to identify and order parts from local distributors or online store. Control Package wiring diagram interpretation and basic maintenance are all presented in a combination hands-on / instructor led lecture format. Any original course documentation and certificates are provided to all attendees for company records at the end of the program.

#### Topics

- Fail-Safe Operational Theory
- Mechanical assemblies for all RTS platforms CM - CL - FL - FQ.
- Detailed focus on Ball Screw assemblies & Spring Canisters.
- Detailed focus on both Brake (Fail-Safe & Spring Damping) assemblies.
- Focus on optional Hand-Wheel over-ride assemblies.
- Electronic Board Sets: Logic Board – VFD – Encoder – Motor / location, function, functionality.
- Programming / Set-Up including Speed Controls both (pulsing & non-pulsing) speed changes. Binary Inputs / outputs.
- Alarm function code identification & clearing.
- Smart Tool II Training.

#### Audience

Repair techs of end users, LBP's, distributors, Final Control Lifecycles Service techs, etc.

#### Prerequisite(s)

It is recommended that students bring an android device for Smart Tool AppTraining. A dongle is required for IRDA communication. A single demo device is available for the training.

**Bettis M2CP & TEC2 Actuator Maintenance & Field Service - Intermediate - VA112**  
CEUs – 1.8

**Overview**

This advanced course teaches students how to install and configure optional control modules for the Bettis M2CP and TEC2 actuators. All students will be tested on the ability to setup, configure, and troubleshoot various actuator control modules. Students will configure DCMLink to utilize advanced diagnostics tools, live monitoring, and transfer configuration files.

**Topics**

- Install and configure M2CP Intermediate Switch Modules
- Install and configure TEC2 Optional Control Modules
- Interpret and diagnose Error Alarms and Messages
- Installing DCMLink Software, setting up Networks and troubleshooting

**Prerequisites**

VA111 or a minimum of 2 years of hands on experience with the products.

**Bettis XTE3000 Maintenance & Field Service - Intermediate - VA135**  
CEUs – 1.6

**Overview**

This course presents how to retrofit legacy ICON3000 actuators with current cards. Attendees will complete a full tear down and reassembly on an ICON3000 to reinforce the theory of operation and component identification. Various software programs will be utilized to program processor cards. In depth review of advanced configurations, maintenance and troubleshooting practices.

**Topics**

- Identify main mechanical and electrical components
- Replacing older version electronics cards
- Optional communication/BUS cards
- Utilization of ICON 2K, 4K, and AManager software to program cards
- Diagnosing and resolving error codes

**Audience**

Field Service Technicians  
Sales Engineers  
Quotation Managers  
Instrumentation and Control Technicians

**Prerequisites**

VA134 or a minimum of 2 years of hands-on experience with the product.

**Bettis Pneumatic Rack & Pinion and Scotch Yoke Actuator Maintenance – Intermediate - VA103**  
CEUs – 2.8

**Overview**

A 4-day class introducing comprehensive information concerning the installation, operation and maintenance of Emerson Bettis™ Houston WACC products.

**Topics**

- Valve Automation Center Contract Review
- Installation/Maintenance Instruction Manuals
- Product Serial Numbers Review
- Service Procedure Index Review
- General Operating/Maintenance Instructions
- General Servicing Information on RPB, RPC, RPD, RPE, CB, CBA, CBB, CBAx30, HD, T, and G-Series Actuators Review
- Hands-on Training-EG; Conversions of actuator fail directions from CW to CCW and CWW to CW
- Field Service Work Performed by VAC's, Bettis Houston WACC Procedure Review
- Five days of Practical Exercises Involving the Disassembly and Reassembling of Emerson Bettis™ Houston WACC Products
- Features and Benefits Emerson Bettis Houston WACC Products for field maintenance
- How to trouble shoot field problems
- How to add features (options) to existing actuators
- Introduction to pneumatic controls
- Introduction to actuator to valve mounting hardware

**Prerequisites**

Work in the valve automation industry: shop assembly or field maintenance

**Bettis SCE 300 & Keystone EPI2 Product & Service – Introduction - VA133**  
CEUs – 1.2

**Overview**

This 2-day course presents the fundamental aspects of Bettis SCE actuators and the Keystone EPI2. Attendees are presented with essentials of design and operation and how they operate the valves. Basic components and assemblies are identified to aid in understanding the basic controls, applications, and mechanical operation. Each student will learn how to set travel limits, torque limits and operate an actuator on or off the valve. Model number interpretation, document relevance (Spec Sheet; Manuals; Wiring Diagrams; Outlines; Assembly Drawing) and support resources will be discussed. How to identify and order parts from local distributors or online store. Control Package wiring diagram interpretation and basic maintenance are all presented in a combination hands-on / instructor led lecture format. Any original course documentation and certificates are provided to all attendees for company records at the end of the program.

**Topics**

- Quarter Turn applications
- Historical Perspective Bettis small ¼ turn electric actuators
- Mechanical Principal of Operation
- Electrical Principal of Operation
- Model number identification
- Wiring diagram interpretation
- Control Inputs- analog and discreet
- Feedback outputs – analog and discreet
- Optional Modules OM1 and OM13
- Optional Module OM3
- Stepper motor theory and practical function
- Speed output adjustment
- Torque output adjustment
- Status LED codes and fixes.
- Bluetooth and Amanager for analog units.
- DeviceNet and Profibus Optional Modules
- Part numbers, ordering and inventory

**Audience**

Repair techs of end users, LBP's, distributors, Final Control Lifecycle Service techs, etc.

**Prerequisite**

Experience with electric actuator (EIM, Biffi, Bettis, etc.)

### Daniel - Basic Fluid Flow Measurement Course - D4119 CEUs – 2.1

#### Overview

This 3-day course is foundation training for technicians, operators, technical support staff, and others who require knowledge of fluid flow measurement, meter selection, maintenance and proving methods. This course relates theory to practice which gives participants a better understanding and appreciation of the oil and gas industry. It is recommended in advance of product specific training courses.

#### Topics

- Introduction to Fluid Flow Measurement
- Basic Flow Measurement Laws
- Types of Fluid Flow Measurement
- Basic Reference Standards
- From Theory to Practice
- Fluids
- Flow
- Operations Considerations
- Maintenance of Metering Equipment
- Measurement and Meters
- Differential Meters
- Linear and Special Meters
- Read outs and Related Devices
- Proving Systems
- Auditing

#### Prerequisites

It is recommended that participants have basic understanding of process instrumentation prior to taking this training.

### Daniel Senior Orifice Fitting – Model 2000 - Introduction - D4420 CEUs – .7

#### Overview

The students will learn the operation and how to repair and troubleshoot the Model 2000.

#### Topics

- Theory of Operation
- "C" Style vs. Model 2000
- Maintenance
- Operation Instructions
- Installation
- Hands-On Learning
- Troubleshooting
- New Features of M2000

#### Audience

This 1-day course is for the beginner or experienced technicians.

#### Prerequisites

Basic knowledge for flow measurement.

### Daniel - Metering Supervisory and Control Systems Operation and Maintenance - D4540 CEUs – 1.4

#### Overview

This 2-day course provides students with an introduction into the operation and functionality of a DanPac Metering Supervisory Control System. The instructor will explain the metering system architecture, its function and system administration. Navigation of the operator interface, specific features, basic troubleshooting and benefits of central data collection will also be explained. Full supporting literature will be made available to students.

#### Topics

- Introduction to DanPac System Architecture
- Supervisory Operator Interface Graphics and Controls
- Administration and Security
- Communication Interface
- Plant Control Functions
- System Status Conditions
- Reporting System
- Alarm Handling
- Basic Diagnostics
- System Troubleshooting

#### Prerequisites

Participants should be proficient in personal computer operations and have a basic knowledge of flow measurement

### Daniel Ultrasonic Flowmeter with Mark III Electronics - Introduction - e4610



#### Overview

This Course introduces the basic elements and concepts of the Daniel Ultra Sonic Flow Meter, equipped with MarkIII Electronics. Historical look at transducers, concepts involved with Flow Meters, Wiring Connections, and MeterLink Software.

Basic understanding of USM with MarkIII Electronic

### Daniel Natural Gas Orifice Flow Measurement - Advanced - D4320 Overview CEUs - 2.1

#### Overview

This 3-day course covers application of metering to natural gas. Coverage of the latest concepts of design and equipment use will be presented to broaden the knowledge of the attendees.

#### Topics

- Design of Meter Stations
  - Contract Requirements
  - Other Concerns
  - Single Versus Multiple Tubes
  - Design Problems
  - Economics Versus Accuracy
- Accuracy of Gas Flow Measurement
  - Definition
  - How Obtained
  - New Concepts
- Influences in Gas Measurement
  - FERC 636 (Government)
  - Economics
  - Standards
  - New Technology
- New Metering Concepts
  - Computers as Analysis
  - New Devices
  - Ultrasonics
  - Vortex Shedding
  - Coriolis
- Future
  - Energy Forecasts
  - U.S. Gas Industry
  - World Gas Industry
- Summary

#### Audience

The course is designed for experienced gas measurement personnel with basic fundamental knowledge of meters and their operation.

### Daniel Natural Gas Orifice Measurement - Introduction - D4120 CEUs - 2.1

#### Overview

This 3-day course covers basic principles, application, operation, calculation and maintenance of meters used in the measurement of gas with emphasis on natural gas.

#### Topics

- Introduction and Overview: Definition of Flow Measurement and a Brief History and Coverage of Common Terms Used in Gas Measurement
- Introduction to Types of Meters
  - Positive Displacement
  - Inferential Head
  - Turbine
  - Others
- Standards for Gas Measurement
- Principles of Meter Operation and Systems
  - Positive Displacement
  - Flow Requirements
  - Measurement System (Readout)
- Meter Details
  - Orifice
  - Nozzle
  - Positive Displacement
  - Ultrasonic
  - Vortex Shedding
  - Target
  - Other
- Secondary System Details
  - Mechanical
  - Electronic
- Accuracy
  - Source of Inaccuracy
    - System
  - Summary
  - Accuracy
  - Economics

#### Audience

The course is designed for Engineers, field technicians and accounting personnel. Practical examples of real metering facilities will be covered.

### Daniel Compact Prover Operation & Maintenance - D4270 CEUs – 2.1

#### Overview

This 3-day course covers the operation, installation and maintenance of the Daniel Compact Prover™.

#### Topics

- Theory of Operation: Double Chronometry and Specifications
- Overview of the Parts Which Make up the Compact Prover such as Actuator Assembly, Pneumatic Spring Chamber, Piston and Poppet, Optical Switches, Hydraulic Motor and Pump, and Solenoid Valve
- Installation: Prover and Meter Location, Nitrogen Spring Plenum Setting, and Power Requirements
- Troubleshooting and Repair of: Safety Barriers, Seal and O-ring Replacement, Detector Switches, Interface Board, Hydraulic and Nitrogen System, and Spare Parts
- Overview of Calibration: Seal Leak Test, Upstream and Downstream Calibration, and Waterdraw Data Sheet
- Overview of Prover Electronics: Programming, Input and Data Modes Using Software/Local Display, Circuit Module Description, and Diagnostics
- Proving Operations: Direct Proving and Master Meter Proving
- Prover Maintenance

#### Prerequisites

Basic knowledge of flow measurement.

### Daniel Gas/Liquid Ultrasonic Meters Operation & Maintenance - D4230/D4280 CEUs – 2.5

#### Overview

This 3-1/2-day course prepares students to install, operate, and maintain Daniel multipath ultrasonic flow meters. In addition to classroom instruction, the training course includes hands-on experience using the flowmeter, simulator and diagnostic software.

#### Topics

- Basics of Sound Waves
- How Ultrasonic Flow Meters Work and Their Advantages over other Meters
- The Performance Characteristics of Transit Time Ultrasonic Flow Meters
- System Components and Mark III Electronics, including the Central Processing Unit (CPU) Board and the Option Board
- Meter Mechanics
- Removal and Installation of Transducer Assemblies
- Volumetric and Mass Ultrasonic Gas Flow Measurement
- Meter Installation Considerations
- Inform the Instructor if Working on Liquid Meter

### Daniel S600 Flow Computers Operation & Maintenance - D4260

CEUs – 2.1

#### Overview

This 3-day course provides students with an appreciation of the operation, design, capabilities and configuration of the S600 flow computer. This hands-on course deals with file transfer and machine recovery as part of the maintenance scope. The instructor will make use of the latest configuration software. Full supporting literature will be made available to all students.

#### Topics

- Introduction to the S600
- Board Removal and Layout
- Keypad Access and Security
- Menu Navigation
- Data/Mode Changing
- Alarm Handling and Configuration
- Configuring and Generating Reports
- Application Specific Functions
- Cold/Warm Starting Modes
- File Back-Up and Download
- Using the Configuration Software

#### Prerequisites

Basic knowledge of flow measurement.

### Daniel S600 + Flow Computers Operation and Maintenance - D4262

CEUs – 2.1

#### Overview

This 3-day course provides students with an appreciation of the operation, design, capabilities and configuration of the S600+ flow computer. This hands-on course deals with file transfer and machine recovery as part of the maintenance scope. The instructor will make use of the latest configuration software. Full supporting literature will be available to all students.

#### Topics

- Introduction to the S600+
- Board Removal and Layout
- Keypad Access and Security
- Menu Navigation
- Data/Mode Changing
- Alarm Handling and Configuration
- Configuring and Generating Reports
- Application Specific Functions
- Cold/Warm Starting Modes
- File Back-Up and Download
- Using the Configuration Software

#### Prerequisites

Basic knowledge of flow measurement

### Daniel Control Valves and Turbines Operation & Maintenance - D4290

CEUs – 2.1

#### Overview

This 3-day course covers the operation, installation and maintenance of the Daniel control valve and turbines.

#### Topics

- Theory of operation: Turbines, Valves, Digital Pilots
- Disassembly and Reassembly of Turbine Internals
- Disassembly and Reassembly of Valve Cylinder Assemblies
- Disassembly and Reassembly of Digital Pilots
- Valve Needle Valve Adjustment
- 'A' series vs. 'B' Series Control Valves
- Turbine Pick-Off Sensor and Preamp
  - Flow Conditioning
  - Parity vs. UMB Series Turbine
  - Meter Troubleshooting

#### Prerequisites

Basic knowledge of flow measurement.

### DeltaV System Administration - 7027 CEUs – 3.2

#### Overview

This 4-1/2-day course is designed for control system administrators, process control engineers and IT specialist responsible for managing, installing, and commissioning a DeltaV system. This course includes access to a virtual DeltaV system to practice and review course workshops complete with brief recorded demonstrations available after course completion.

#### Topics

- Overview of system components and topologies
- DeltaV domain setup, including independent deltav domain controllers
- DeltaV installation procedures
- Licensing
- Import and export of configuration
- Firmware upgrades
- Controller health diagnostics
- User administration
- Configuration Database administration
- Creating additional workstations
- Auto Update services
- Continuous historian administration
- Advanced continuous historian administration
- Remote desktop services
- Event chronicle administration
- Network Time Protocol configuration/diagnostics
- Backup and restore procedures

#### Audience

This course is designed for control system administrators, process control engineers and IT specialist responsible for managing, installing, and commissioning a DeltaV system.

### DeltaV System Administration - Virtual - 7027V CEUs – 3.2



#### Overview

This 4-1/2-day course is designed for control system administrators, process control engineers and IT specialist responsible for managing, installing, and commissioning a DeltaV system. This course includes access to a virtual DeltaV system to practice and review course workshops complete with brief recorded demonstrations available after course completion.

#### Topics

- Overview of system components and topologies
- DeltaV domain setup, including independent deltav domain controllers
- DeltaV installation procedures
- Licensing
- Import and export of configuration
- Firmware upgrades
- Controller health diagnostics
- User administration
- Configuration Database administration
- Creating additional workstations
- Auto Update services
- Continuous historian administration
- Advanced continuous historian administration
- Remote desktop services
- Event chronicle administration
- Network Time Protocol configuration/diagnostics
- Backup and restore procedures

#### Audience

This course is designed for control system administrators, process control engineers and IT specialist responsible for managing, installing, and commissioning a DeltaV system.

### DeltaV Advanced Control Suite - Virtual - 7201V CEUs – 3.2



#### Overview

This 4-1/2-day course introduces students to the advanced control tools available within the DeltaV system and how they may be used to improve plant operations. The principal technology that is utilized in each product will be discussed. The areas of improvement that may be achieved will be detailed. Also, each student will gain hands on experience with these tools in class exercises based on realistic process simulations.

#### Topics

- The Control Foundation in DeltaV
- Traditional Tools e.g. Override, Cascade, Ratio
- Improvements Provided by Advanced Control
- DeltaV Inspect with InSight
- Detection of Abnormal Conditions
- Performance Indices
- Performance Reports
- DeltaV Tune with InSight
- Measurement of Process Dynamics
- Tuning Methods
- Tuning Response
- Process Learning
- Adaptive Tuning
- Adaptive Control
- DeltaV Fuzzy
- Principles of Fuzzy Logic Control
- FLC Function Block, Tuning
- DeltaV Predict
- MPC for Multi-Variable Control
- Model Identification, Data Screening
- Simulation of Response, Tuning
- DeltaV Neural
- Creation of Virtual Sensor
- Data Screening, Training
- DeltaV Simulate Suite
- Process Simulation
- Simulate Pro

#### Prerequisites

7009, DeltaV Implementation I or equivalent field experience.



### DeltaV Live Graphics Interface – Advanced - 7425 CEUs – 3.2

#### Overview

This 4-1/2-day course is for process control engineers responsible for configuring graphics in the DeltaV Live operator interface. This course teaches basic options through advanced configuration topics.

#### Topics

- Graphics Studio
- Environment Customization
- DeltaV Live
- DeltaV Live Administration
- Display Interactions
- Conversion Functions
- Class Based Graphical Element Modules (GEMs)
- Contextual Displays
- Custom Faceplates
- Pop Up pictures
- Forms
- Display Layout Configuration – Multi-Monitor Configuration
- Frame Customization
- Publishin
- Display Hierarchy
- Script Assistant
- Language Changes
- Theme GEMs
- Importing & Exporting Displays

#### Audience

This course is designed for process and process control engineers responsible for obtaining key production data, maintaining, configuring and troubleshooting a DeltaV system with the DeltaV Live user interface.

### DeltaV Live Graphics Interface – Advanced – Virtual – 7425V CEUs – 3.2



#### Overview

This 4-1/2-day course is for process control engineers responsible for configuring graphics in the DeltaV Live operator interface. This course teaches basic options through advanced configuration topics.

#### Topics

- Graphics Studio
- Environment Customization
- DeltaV Live
- DeltaV Live Administration
- Display Interactions
- Conversion Functions
- Class Based Graphical Element Modules (GEMs)
- Contextual Displays
- Custom Faceplates
- Pop Up pictures
- Forms
- Display Layout Configuration – Multi-Monitor Configuration
- Frame Customization
- Publishin
- Display Hierarchy
- Script Assistant
- Language Changes
- Theme GEMs
- Importing & Exporting Displays

#### Audience

This course is designed for process and process control engineers responsible for obtaining key production data, maintaining, configuring and troubleshooting a DeltaV system with the DeltaV Live user interface

### DeltaV Operate Graphics Interface – Advanced - 7025 CEUs – 3.2

#### Overview

This 4-1/2-day course is for process control engineers responsible for configuring advanced functionality in the DeltaV user interface. This course expands on graphic topics covered in both the DeltaV Implementation, course 7009 and DeltaV Implementation II, course 7017.

#### Topics

- Visual Basic Primer
- Forms
- Modules
- Schedules
- User Preferences
- Picture Sizing
- Environment Customization\
- Custom Faceplates
- Function Block Faceplates
- FRS Functions
- Pop Up Menus
- Color Threshold Tables
- Custom Dynamos
- Tag Groups
- Key Macro Editor
- Theme Dynamos

#### Audience

This course is for process control engineers responsible for configuring advanced functionality in the DeltaV user interface.

#### Prerequisites

Course 7009, DeltaV Implementation I

### DeltaV Operate Graphics Interface – Advanced - Virtual - 7025V CEUs – 3.2



#### Overview

This 4-1/2-day course is for process control engineers responsible for configuring advanced functionality in the DeltaV user interface. This course expands on graphic topics covered in both the DeltaV Implementation course 7009 and DeltaV Implementation II course 7017.

#### Topics

- Visual Basic Primer
- Forms
- Modules
- Schedules
- User Preferences
- Picture Sizing
- Environment Customization
- Custom Faceplates
- Function Block Faceplates
- FRS Functions
- Pop Up Menus
- Color Threshold Tables
- Custom Dynamos
- Tag Groups
- Key Macro Editor
- Theme Dynamos

#### Audience

This course is for process control engineers responsible for configuring advanced functionality in the DeltaV user interface.

#### Prerequisites

Course 7009, DeltaV Implementation I

### DeltaV Model Predictive Control – 7202 CEUs – 2.4

#### Overview

This 3-1/2-day course is designed for process and control engineers who are applying DeltaV Predict and Predict Pro. It provides practical examples of how to determine the benefits of MPC application and how this control may be used to meet specific application requirements.

Students will gain hands on experience through lab exercises based on realistic dynamic process simulations.

#### Topics

##### How to Justify an MPC Project

- Evaluating the Cost of Process Variation
- Estimating the Reduction in Variation that is possible using MPC
- Calculating the Benefit of Maximizing throughput when plant production is restricted by Input Limits or Measurable Constraint

##### Meeting Application Requirements

- Meeting Control Requirements when the Response Times are Very Different
- Understanding the Design and Testing of an Integrating Process

##### Tailoring Control Performance

- Placing more Emphasis on Selected Control or Constraint Parameters
- Improving Control Performance when the Process is Dead Time Dominant
- Compensating for Large Changes in Process Gain or Dynamics
- Minimizing the Impact of Process Noise on Control Performance

##### MPC Application

- Selecting and Applying MPC, MPC-Pro and MPC-Plus Blocks

##### Optimizing Control

- Optimizing the Control Using the MPC-Pro or MPC-Plus Blocks

#### Audience

This course is designed for process and control engineers who are applying DeltaV Predict and Predict Pro.

#### Prerequisites

7201 DeltaV Advanced Control

### DeltaV Model Predictive Control - Virtual - 7202V CEUs – 2.4



#### Overview

This 3-1/2-day course is designed for process and control engineers who are applying DeltaV Predict and Predict Pro. It provides practical examples of how to determine the benefits of MPC application and how this control may be used to meet specific application requirements.

Students will gain hands on experience through lab exercises based on realistic dynamic process simulations.

#### Topics

##### How to Justify an MPC Project

- Evaluating the Cost of Process Variation
- Estimating the Reduction in Variation that is possible using MPC
- Calculating the Benefit of Maximizing throughput when plant production is restricted by Input Limits or Measurable Constraint

##### Meeting Application Requirements

- Meeting Control Requirements when the Response Times are Very Different
- Understanding the Design and Testing of an Integrating Process

##### Tailoring Control Performance

- Placing more Emphasis on Selected Control or Constraint Parameters
- Improving Control Performance when the Process is Dead Time Dominant
- Compensating for Large Changes in Process Gain or Dynamics
- Minimizing the Impact of Process Noise on Control Performance

##### MPC Application

- Selecting and Applying MPC, MPC-Pro and MPC-Plus Blocks

##### Optimizing Control

- Optimizing the Control Using the MPC-Pro or MPC-Plus Blocks

#### Audience

This course is designed for process and control engineers who are applying DeltaV Predict and Predict Pro.

#### Prerequisites

DeltaV Advanced Control Suite - 7201

### DeltaV Batch Analytics Model Builder – Introduction - e7046 CEUs - .80



#### Overview

This 8-hour (average duration) on-line course provides an orientation of Batch Analytics Model Builder. The course includes audio presentations, demonstrations, hands-on practices, hands-on workshops, and quizzes. Course access is 12 months. Upon completion of this course, the student will be able to:

- Define basic principles of Batch Data Analytics and their use in fault detection and quality parameter prediction
- Use the Batch Data Analytics Model Builder application to build and deploy a project for fault detection and quality parameter prediction
- Users will be able to recognize and navigate the screens needed to build a model in Batch Analytics
- Users need to define batch logic, stage logic, and initial condition logic needed for model development
- Users will be able to interpret analytic data of the Model Builder application using a saline example
- Users will be able to build a Batch Data Analytics model

#### Topics

- Batch Analytics Overview
- Batch Analytics Model Builder Overview
- Batch Analytics Viewer Overview
- Batch Saline Simulation
- Benefits of Using Batch Analytics
- Batch Analytics Manager Administration
- Batch Logic, Stage Logic, and Initial Logic Required to Build a Model
- Batch Analytics Model Builder – Equipment
- Batch Analytics Model Builder – Product
- Batch Analytics Model Builder – Model

#### Audience

This course is designed for Chemometricians, Process Engineers, Quality Engineers, and Process Control Engineers.

### DeltaV Batch Analytics Operator – Introduction - e7044 CEUs - .6



#### Overview

This 6-hour (average duration) on-line course provides an orientation of Batch Analytics and how it is used in a production environment. The course includes audio presentations, demonstrations, hands-on practices, hands-on workshops, and quizzes. Upon completion of this course, the student will be able to:

- Define basic principles of Batch Analytics
- Identify how Batch Analytics is used in fault detection and quality parameter prediction
- Identify the Batch List, Quality Prediction, and Fault Detection screens
- Monitor a fault
- Interpret analytic data of a saline example
- Identify the root cause of a detected fault

#### Topics

- Batch Analytics Overview
- Batch Analytics Model Builder Overview
- Batch Analytics Viewer Overview
- Batch Saline Simulation
- Benefits of Using Batch Analytics
- Batch Analytics Viewer – Batch List Tab
- Batch Analytics Viewer – Fault Detection Tab
- Batch Analytics Viewer – Quality Prediction

#### Audience

This course is designed for operators, process engineers, and management.

#### Prerequisites

DeltaV Batch experience and Microsoft Windows experience is required.

### DeltaV Communication Bus Interfaces – 7037 CEUs – 2.5

#### Overview

This 3-1/2-day course covers the integration of fieldbus compliant devices using DeltaV systems. Upon completion of the course the student will be able to install, configure and verify proper operations of AS-I, Profibus DP, DeviceNet Serial, EtherNet IP, and Wireless HART® devices, including proper wiring practices. The AMS Intelligent Device Manager will be used to interrogate PROFIBUS DP and Wireless HART devices. The target audience usually does the following: Responds to work orders created to calibrate, troubleshoot, repair, service, and replace instruments and valves

- Monitors alerts to preemptively address problems prior to operators seeing a problem in the control room
- Provides loop testing and assistance with instrumentation on plant turnarounds, startups, and for project work
- Improves process availability and reduces operations and maintenance costs

#### Topics

- Communication Bus Introduction
- AS-I Overview
- AS-I: Wiring and Installation
- AS-I Network with DeltaV
- PROFIBUS DP Overview
- PROFIBUS Wiring and Installation
- Configuring a PROFIBUS Segment
- Device Net Overview
- Device Net Diagnostics and Configuration
- Troubleshooting
- Serial Interface
- HART® Overview
- Ethernet I/O Overview
- Wireless I/O Overview

#### Audience

The hands-on workshops with DeltaV along with AMS Device Manager will address areas relating to the instrument technician's daily tasks.

#### Prerequisites

7009 DeltaV Implementation I or 7018 DeltaV Hardware Installation and Troubleshooting.

### DeltaV Advanced Control Suite – 7201 CEUs – 3.2

#### Overview

This 4-1/2-day course introduces students to the advanced control tools available within the DeltaV system and how they may be used to improve plant operations. The principal technology that is utilized in each product will be discussed. The areas of improvement that may be achieved will be detailed. Also, each student will gain hands on experience with these tools in class exercises based on realistic process simulations.

#### Topics

- The Control Foundation in DeltaV
- Traditional Tools e.g. Override, Cascade, Ratio
- Improvements Provided by Advanced Control
- DeltaV Inspect with InSight
- Detection of Abnormal Conditions
- Performance Indices
- Performance Reports
- DeltaV Tune with InSight
- Measurement of Process Dynamics
- Tuning Methods
- Tuning Response
- Process Learning
- Adaptive Tuning
- Adaptive Control
- DeltaV Fuzzy
- Principles of Fuzzy Logic Control
- FLC Function Block, Tuning
- DeltaV Predict
- MPC for Multi-Variable Control
- Model Identification, Data Screening
- Simulation of Response, Tuning
- DeltaV Neural
- Creation of Virtual Sensor
- Data Screening, Training
- DeltaV Simulate Suite
- Process Simulation
- Simulate Pro

#### Prerequisites

7009, DeltaV Implementation I or equivalent field experience.

### DeltaV Control Loop - Introduction – 9025 CEUs – 3.2

#### Overview

This 4-1/2-day course for personnel new to automation and covers process control fundamentals as well as the practical aspects of control system design and applications. Upon completion of this course the student will be able to effectively understand and work with single and multi-loop control strategies. Interactive workshops allow the student to apply what they learn in the class.

#### Topics

- Background — Historic Perspective
- Measurements — Basic Transmitter Types, Limitations
- Analyzers — Examples of On-Line Analyzers
- Final Elements - Valves and Variable Speed Drives
- Field Wiring and Communications — Traditional, HART®, Foundation fieldbus, WirelessHART™
- Control Strategy Documentation — Plot Plan, Flow Sheet, P&ID, Loop Sheet
- Operator Graphics and Metrics — Considerations in Display Design
- Process Characterization — Identifying Process Dynamics and Gain
- Control Objectives
- Single Loop Control — Basis for PID, Guideline in Selecting PID Structure, Action
- Tuning and Loop Performance - Manual and Automated Tuning Techniques
- Multi-loop Control — Feedforward, Cascade, Override, Split-range, Valve Position Control
- Model Predictive Control — Addressing Difficult Dynamics, Interactive Processes
- Process Modeling — Development of Process Simulation for Control System Checkout
- Application Examples — Batch, Continuous, Combustion, Distillation, Unit Coordination

#### Audience

This course is for engineers, managers, technicians, and others that are new to process control. This course includes the practical aspects of control design and process applications that course developers personally learned through years of hands on experience while designing and commissioning process control applications.

#### Prerequisites

Windows experience.

### DeltaV Cybersecurity – 7026 CEUs – 3.2

#### Overview

The 4-1/2-day DeltaV Cybersecurity course focuses on the DeltaV Security Manual and the practical implementation of the guidance provided within. Students will engage in activities to properly apply Emerson's Defense-in-Depth strategies so that students can have the skills to apply these same strategies on their DeltaV systems. Students are encouraged to read the DeltaV Security Manual before attending class.

#### Topics

DeltaV Deployment Guidelines & Physical Security

- Define the expected DeltaV installation environment
- Define physical access rules (cabinets, switches, consoles, etc.)

DeltaV Area Control Network

- Define proper network segmentation and topology rules
- Use DeltaV Firewall-IPD and Smart Switches
- Lock and protect embedded nodes

Communications Security & Remote Access to DeltaV

- Define communication and security requirements for remote access
- Use Emerson Smart Firewall
- Deploy Remote Desktop Gateway server
- Configure DeltaV remote desktop server

Active Directory Design & User Account Management

- Define Active Directory implementation guidelines
- Create customized DeltaV users and groups
- Audit user privileges
- Configure password policies through Group Policy Objects

Device Hardening & Event Logging

- Define device internal and interface protection rules
- Deploy DeltaV Endpoint protection and Application Whitelisting
- Configure Windows Firewall
- Create USB/Removable media Group Policy Object
- Configure syslog and other device logs to report to a System Information and Event Management (SIEM) appliance
- Configure DeltaV Network Security Monitoring appliance

### DeltaV Cybersecurity – 7026 – Continued...

- Use and customize SIEM dashboard to show system events

#### Software Patching

- Define how to obtain and install security patches
- Use Emerson's Automated Patch Management solution

#### Backup & Recovery

- Define best practices and available technologies to backup critical data
- Use the DeltaV Backup & Recovery (Acronis) software

#### Audience

DeltaV System Administrators or IT personnel responsible for implementing DeltaV security

#### Prerequisites

7027

### DeltaV Cybersecurity – Virtual - 7026V CEUs – 3.2



#### Overview

The 4-1/2-day DeltaV Cybersecurity course focuses on the DeltaV Security Manual and the practical implementation of the guidance provided within. Students will engage in activities to properly apply Emerson's Defense-in-Depth strategies so that students can have the skills to apply these same strategies on their DeltaV systems. Students are encouraged to read the DeltaV Security Manual before attending class.

#### Topics

DeltaV Deployment Guidelines & Physical Security

- Define the expected DeltaV installation environment
- Define physical access rules (cabinets, switches, consoles, etc.)

DeltaV Area Control Network

- Define proper network segmentation and topology rules
- Use DeltaV Firewall-IPD and Smart Switches
- Lock and protect embedded nodes

Communications Security & Remote Access to DeltaV

- Define communication and security requirements for remote access
- Use Emerson Smart Firewall

Deploy Remote Desktop Gateway server

### DeltaV Cybersecurity – Virtual - 7026V – Continued...

- Configure DeltaV remote desktop server

#### Active Directory Design & User Account Management

- Define Active Directory implementation guidelines
- Create customized DeltaV users and groups
- Audit user privileges
- Configure password policies through Group Policy Objects

#### Device Hardening & Event Logging

- Define device internal and interface protection rules
- Deploy DeltaV Endpoint protection and Application Whitelisting
- Configure Windows Firewall
- Create USB/Removable media Group Policy Object
- Configure syslog and other device logs to report to a System Information and Event Management (SIEM) appliance
- Configure DeltaV Network Security Monitoring appliance
- Use and customize SIEM dashboard to show system events

#### Software Patching

- Define how to obtain and install security patches
- Use Emerson's Automated Patch Management solution

#### Backup & Recovery

- Define best practices and available technologies to backup critical data
- Use the DeltaV Backup & Recovery (Acronis) software

#### Audience

DeltaV System Administrators or IT personnel responsible for implementing DeltaV security

#### Prerequisites

7027

### DeltaV Essential Operator Training Solution

#### Overview

DeltaV™ Essential Operator Training Solution is an engineered, hands-on, customized learning environment to up-skill your operations workforce. Operators will learn DeltaV operating concepts using curriculum based on their specific displays as well as hands-on practice workshops relevant to their process.

The DeltaV Essential Operator Training Solution includes instructional materials, customized student curriculum, and workshops all customized to your specific graphics and module types. Student workshops include low fidelity tieback simulation to demonstrate module functionality and perform workshops.

DeltaV Essential Operator Training Solution is available in three delivery formats.

- 1) Traditional classroom with live instructors and equipment
- 2) Virtual classroom environment with live online instruction and DeltaV distributed control systems (DCS)
- 3) A new blended learning environment that uses state-of-the-art technologies to host training in the cloud.

For more information, contact your local Emerson sales office or visit: [www.emerson.com/education](http://www.emerson.com/education)

### DeltaV Fieldbus Devices Maintenance – 7030 CEUs – 2.8

#### Overview

This 4-day lecture/lab course provides maximum hands-on experience working with FOUNDATION™ fieldbus instruments such as: the FIELDVUE™ Digital Valve Controller, Rosemount Pressure and Temperature Transmitters. The student will use the DeltaV control system to commission fieldbus devices, assign foundation fieldbus function blocks to field devices, troubleshoot using diagnostics and AMS Device Manager to manipulate device parameters.

#### Topics

- DeltaV Saleable System Overview
- Macro Cycle Execution
- Fieldbus Function Blocks
- FIELDVUE™ Theory of Operation
- Transmitter Theory of Operation
- AMS Device Manager Methods
- Fieldbus Wiring Practices
- System Troubleshooting
- Accessing Fieldbus Devices
- Alarms and Alerts at DeltaV Workstations
- Segment Checkout Procedures
- Replace Wizard

#### Audience

This course is for individuals responsible for maintaining, troubleshooting, calibrating, and modifying FOUNDATION™ fieldbus device parameters.

#### Prerequisites

Course 7009, DeltaV Implementation I, or 7018, DeltaV Hardware Installation and Troubleshooting

### DeltaV Fieldbus Devices Configuration & Control – 7032 CEUs – 2.8

#### Overview

This 4-day lecture/lab course provides maximum hands-on experience working with FOUNDATION™ fieldbus instruments such as: the FIELDVUE™ Digital Valve Controller, Rosemount Pressure and Temperature Transmitters. The student will use the DeltaV control system to commission fieldbus devices, assign foundation fieldbus function blocks to field devices, troubleshoot using diagnostics and AMS Device Manager to manipulate device parameters.

#### Topics

- FOUNDATION™ fieldbus Overview
- Macro Cycle Execution
- Fieldbus Function Blocks
- Control Anywhere
- Fieldbus Wiring and Installation
- Segment Checkout Procedures
- Commissioning and Configuring Devices
- Control Strategy Configuration
- Configuring an Operator Display

#### Audience

This course is for individuals responsible for designing and configuring FOUNDATION™ fieldbus segments; as well as analyzing the fieldbus macro cycle, troubleshooting fieldbus segments/devices and modifying FOUNDATION™ fieldbus parameters.

#### Prerequisites

7009 DeltaV Implementation I or 7018 DeltaV Hardware Installation and Troubleshooting.

### DeltaV Hardware & Troubleshooting – 7018 CEUs – 2.8

#### Overview

This course provides an overview of the DeltaV Control Network, M- and S-series hardware, and software applications. Upon completion, you will be familiar with the hard-ware and be able to perform troubleshooting techniques. This 4-day course focuses on the hardware components that make up the DeltaV system: M-series controllers and I/O, S-series controllers and I/O (including CHARMs), and DeltaV Smart Switches. Using a combination of lectures and workshops, you will learn how to use operator and diagnostic tools to identify and locate hard-ware-related fault conditions. Workshops provide the opportunity to disassemble and reassemble the M- and S-series hardware and return the system to an operating state. If your systems include bus technologies such as Foundation Fieldbus, we recommend courses 7030, 7032, or 7037. The 7018 course satisfies the prerequisite requirement for these bus course (except 7032)

#### Topics

- DeltaV Overview
- Operator Alarms
- DeltaV Diagnostics
- DeltaV Smart Switches
- DeltaV I/O Cards and Carriers
- Controllers and Power Supplies
- Electronic Marshalling (CHARMs)
- HART® I/O
- DeltaV and AMS Suite Intelligent Device Manager
- Redundant I/O

#### Audience

This course is recommended for instrumentation and maintenance technicians, managers, and configuration engineers who need to know about DeltaV hardware.

#### Prerequisites

Windows Experience



### DeltaV Implementation II – Intermediate - 7017 CEUs – 3.2

#### Overview

During the 4-1/2-day course, the student will be able to identify function block structures, interpret function block status values, design error masking, define nodes, and configure class-based control modules using the Command-Driven algorithm.

This course includes access to a virtual DeltaV system to practice and review course workshops complete with brief recorded demonstrations available after course completion. Create custom faceplates and dynos, configure modules with analog control palette blocks and create simulation for test purposes. This course includes access to brief recorded demonstrations available after course completion, so students can review exercises completed in class.

#### Topics

- Function Block Structures & Status Values
- Analog Control Palette Blocks PID Bias/Gain, Dead time, Ratio, Signal Characterizer, Splitter
- HART® Inputs and Outputs
- HART Device Alarms
- Unit Alarms
- DeltaV Tune with InSight
- Device Control Options
- Class Based Control Modules
- Configuration of Equipment Modules for Supervisory Control
- Custom Faceplates and Dynamos

#### Audience

This course is for process control engineers responsible for designing, implementing and testing configuration using the DeltaV system.

#### Prerequisites

Course 7009, DeltaV Implementation I

### DeltaV Implementation II – Intermediate - Virtual - 7017V CEUs – 3.2



#### Overview

During the 4-1/2-day course, the student will be able to identify function block structures, interpret function block status values, design error masking, define nodes, and configure class-based control modules using the Command-Driven algorithm. This course includes access to a virtual DeltaV system to practice and review course workshops complete with brief recorded demonstrations available after course completion.

#### Topics

- Function Block Structures & Status Values
- Analog Control Palette Blocks PID Bias/Gain, Dead time, Ratio, Signal Characterizer, Splitter
- HART® Inputs and Outputs
- HART Device Alarms
- Unit Alarms
- DeltaV Tune with InSight
- Device Control Options
- Class Based Control Modules
- Configuration of Equipment Modules for Supervisory Control
- Custom Faceplates and Dynamos

#### Audience

This course is for process control engineers responsible for designing, implementing and testing configuration using the DeltaV system.

#### Prerequisites

Course 7009, DeltaV Implementation I

### DeltaV InSight – Virtual – 7201CV CEUs – 0.7

#### Overview

This 1-day course introduces students to DeltaV InSight and how it may be used to improve the plant operations. The measurement of the process dynamics will be discussed, and the DeltaV Tune application will be introduced and used with Adaptive Tuning and Adaptive Control. Also, each student will gain hands on experience with these tools in class exercises based on realistic process simulations.

#### Topics

- DeltaV Tune with InSight
  - Measurement of Process Dynamics
  - Tuning Methods
  - Tuning Response
  - Process Learning
  - Adaptive Tuning
  - Adaptive Control
- DeltaV Inspect with InSight
  - Detection of Abnormal Conditions
  - Performance Indices
  - Performance Reports

#### Prerequisites

7009, DeltaV Implementation I or equivalent field experience.

### DeltaV Batch Operation – 7014 CEUs – 1.8

#### Overview

This 2-1/2-day course uses lectures and hands-on workshops to provide an in-depth overview on operating the DeltaV System. It includes all content in course 7012 plus students will:

- Understand basic batch terminology
- Manipulate Unit Module parameters
- Access the Batch Operator Interface
- Run procedures
- Review batch history data topics
- System Overview
- Accessing DeltaV Operate Window, Menus Displays and Directories
- Discrete, Analog, Regulatory and Cascade Control Module Operation
- Motor Control Module Operation
- Accessing Alarm Displays/Alarm Handling
- Accessing Real-time/Historical Trend Data
- Accessing Process History View
- Sequential Function Chart Operation
- Phase and Recipe Controls
- Batch Operator Interface
- Batch Historian
- Campaign Manager

#### Audience

This course is for operators, supervisors, and managers responsible for the operation of batch processes using DeltaV system.

### DeltaV Batch Operation - Virtual - 7014V CEUs – 1.8



#### Overview

This 2-1/2-day course uses lectures and hands-on workshops to provide an in-depth overview on operating the DeltaV System. It includes all content in course 7012 plus students will:

- understand basic batch terminology
- manipulate Unit Module parameters
- access the Batch Operator Interface
- run procedures
- review batch history data

#### Topics

- System Overview
- Accessing DeltaV Operate Window, Menus Displays and Directories
- Discrete, Analog, Regulatory and Cascade Control Module Operation
- Motor Control Module Operation
- Accessing Alarm Displays/Alarm Handling
- Accessing Real-time/Historical Trend Data
- Accessing Process History View
- Sequential Function Chart Operation
- Phase and Recipe Controls
- Batch Operator Interface
- Batch Historian
- Campaign Manager

### DeltaV Information Technology for Automation Personnel - 7023 CEU'S: 2.1

#### Overview

This 3-day course will provide students with a set of essential information technology (I.T.) skills required to successfully setup, maintain, and troubleshoot a DeltaV distributed control system using a combination of lecture and hands-on workshops. The increase in adoption of technologies such as virtualization, cybersecurity, business system integration, and complex networking demand a new set of skills. This course will distill the core learnings and techniques required from the I.T. skill set, providing a targeted launch point for process control engineers, instrumentation/electrical technicians, I.T. staff, and others whose responsibilities require them to adopt and successfully use these technologies. After attending, students will be prepared to dive deeply into these technologies by attending other higher-level courses.

#### Topics

1. Overview
2. Networking
3. Virtualization
4. Domain
5. Servers
6. DeltaV
7. Security
8. Troubleshooting

#### Audience

DeltaV System Administrators, Process Control Engineers, Instrumentation/Electrical Technicians, and I.T. staff supporting the DeltaV system.

#### Prerequisites

None

### DeltaV Information Technology for Automation Personnel – Virtual - 7023V CEU'S: 2.1



#### Overview

This 3-day course will provide students with a set of essential information technology (I.T.) skills required to successfully setup, maintain, and troubleshoot a DeltaV distributed control system using a combination of lecture and hands-on workshops. The increase in adoption of technologies such as virtualization, cybersecurity, business system integration, and complex networking demand a new set of skills. This course will distill the core learnings and techniques required from the I.T. skill set, providing a targeted launch point for process control engineers, instrumentation/electrical technicians, I.T. staff, and others whose responsibilities require them to adopt and successfully use these technologies. After attending, students will be prepared to dive deeply into these technologies by attending other higher-level courses.

#### Topics

1. Overview
2. Networking
3. Virtualization
4. Domain
5. Servers
6. DeltaV
7. Security
8. Troubleshooting

#### Audience

DeltaV System Administrators, Process Control Engineers, Instrumentation/Electrical Technicians, and I.T. staff supporting the DeltaV system.

#### Prerequisites

None

### DeltaV Continuous Operation – 7012 CEUs – 1.4

#### Overview

This 2-day course (14 hrs.) uses lectures and hands-on workshops to train operators for continuous process operation using the standard DeltaV Operate user interface (for the DeltaV Live user interface, please select course 7412)

Students who complete this course will:

- access operator main displays
- manipulate various control module operating parameters to operate the process
- access faceplates and detail displays
- understand process indications from graphics dynamos
- monitor and acknowledge different alarm conditions
- monitor process performance
- view real-time and historical trend data
- access historical data and event chronicle

Generic curriculum uses the out-of-the-box DeltaV configuration standards library. In most cases, the site configuration will differ from the generic library. After taking the generic course, students will be able to understand the basic layout of the graphics - e.g. the toolbar vs alarm banner, how to access the Alarm Summary page and acknowledge alarms, use of dynamos, where to click to access the Faceplate and Detail Displays. This is considered "platform training" on DeltaV, not process training. For curriculum customized for your site please contact Educational Services for a proposal.

#### Topics

- DeltaV Distributed Control System Overview
- DeltaV Operator Interface
- DeltaV Multi-Monitor Workstations
- Operating Discrete and Analog Control Modules
- Alarms and Events
- Operating Motor Control Modules
- Operating Regulatory and Cascade Control Modules
- DeltaV Trending
- Unit Alarms
- Operating Equipment Modules
- DeltaV SIS

#### Prerequisites

None

#### Audience

This course is for operators, supervisors and managers responsible for the operation of continuous processes using the DeltaV Operate user interface

### DeltaV Continuous Operation - Virtual - 7012V CEUs – 1.4



#### Overview

This 2-day course (14 hrs.) uses lectures and hands-on workshops to train operators for continuous process operation using the standard DeltaV Operate user interface (for the DeltaV Live user interface, please select course 7412)

Students who complete this course will:

- access operator main displays
- manipulate various control module operating parameters to operate the process
- access faceplates and detail displays
- understand process indications from graphics dynamos
- monitor and acknowledge different alarm conditions
- monitor process performance
- view real-time and historical trend data
- access historical data and event chronicle

Generic curriculum uses the out-of-the-box DeltaV configuration standards library. In most cases, the site configuration will differ from the generic library. After taking the generic course, students will be able to understand the basic layout of the graphics - e.g. the toolbar vs alarm banner, how to access the Alarm Summary page and acknowledge alarms, use of dynamos, where to click to access the Faceplate and Detail Displays. This is considered "platform training" on DeltaV, not process training. For curriculum customized for your site please contact Educational Services for a proposal.

#### Topics

- DeltaV Distributed Control System Overview
- DeltaV Operator Interface
- DeltaV Multi-Monitor Workstations
- Operating Discrete and Analog Control Modules
- Alarms and Events
- Operating Motor Control Modules
- Operating Regulatory and Cascade Control Modules
- DeltaV Trending
- Unit Alarms
- Operating Equipment Modules
- DeltaV SIS

### DeltaV Continuous Operation - Blended – 7012B CEUs – 1.2

#### Overview

This course uses lectures and hands-on workshops to train operators for continuous process operation using the standard generic DeltaV™ Operate user interface (for the DeltaV Live user interface, please select course 7412B).

Blended training provides the most flexibility in course scheduling. This is a self-paced training with courses available 24/7 on Emerson's Learning Management System (LMS). Blended courses are comprised of pre-recorded lectures and a cloud based DeltaV machine for workshop exercises using standard generic DeltaV configuration.

Even though this is self-paced, ideally this course could be completed in 2-days (14 hrs.)

Students who complete this course will:

- access operator main displays
- manipulate various control module operating parameters to operate the process
- access faceplates and detail displays
- understand process indications from graphics dynamos
- monitor and acknowledge different alarm conditions
- monitor process performance
- view real-time and historical trend data
- access historical data and event chronicle

Generic curriculum uses the out-of-the-box DeltaV configuration standards library. In most cases, the site configuration will differ from the generic library. After taking the generic course, students will be able to understand the basic layout of the graphics - e.g. the toolbar vs alarm banner, how to access the Alarm Summary page and acknowledge alarms, use of dynamos, where to click to access the Faceplate and Detail Displays. This is considered "platform training" on DeltaV, not process training. For curriculum customized for your site please contact Educational Services for a proposal.

#### Topics

- DeltaV Distributed Control System Overview
- DeltaV Operator Interface
- DeltaV Multi-Monitor Workstations
- Operating Discrete and Analog Control Modules
- Alarms and Events
- Operating Motor Control Modules
- Operating Regulatory and Cascade Control Modules
- DeltaV Trending
- Unit Alarms

**7012B – Continued...**

- Operating Equipment Modules
- DeltaV SIS

**Prerequisites**

None

**Audience**

This course is for operators, supervisors and managers responsible for the operation of continuous processes using the DeltaV Operate user interface.

**DeltaV - pH Control Solutions – 9060  
CEUs – 1.0**

Contact education@emerson.com or call 800-338-8158 for additional information

**DeltaV PMO Configuration Standard – 7076  
CEUs – 3.2****Overview:**

This 4-½ day course will introduce students to the PCSD structure and commonly used PCSD templates for analog, discrete and regulatory control. Students will also learn how to implement new DeltaV control modules using the PCSD library.

Upon completion of this course, the student will be able to:

- Modify existing control strategies while maintaining consistency with the PCSD library
- Add control strategies while maintaining consistency with the PCSD library

**Topics:**

Benefits of a structured approach to configuration

- PCSD Structure
- Operator graphics standards
- Configuration of the following using PCSD class-based modules:
  - Analog value reading and setting
  - Control of discrete devices
  - Loop control
  - Sequential control using Equipment Modules
- Modification of existing PCSD-based control configuration
- PCSD methods for:
  - Module arbitration
  - Mode locking
  - Mode, state and failure propagation
  - Inter-module interfacing
  - Interlocks, permissive and force set points

**Audience:**

This course is designed for engineers and technicians who maintain a DeltaV system configured using the PMO Configuration Standards for DeltaV (PCSD) library.

**Prerequisites:**

Course 7009, DeltaV Implementation I and familiarity with process control.

**DeltaV PMO Configuration Standard - Virtual - 7076V  
CEUs – 3.2****Overview**

This 4-½ day course will introduce students to the PCSD structure and commonly used PCSD templates for analog, discrete and regulatory control. Students will also learn how to implement new DeltaV control modules using the PCSD library.

Upon completion of this course, the student will be able to:

- Modify existing control strategies while maintaining consistency with the PCSD library
- Add control strategies while maintaining consistency with the PCSD library

**Topics:**

Benefits of a structured approach to configuration

- PCSD Structure
- Operator graphics standards
- Configuration of the following using PCSD class-based modules:
  - Analog value reading and setting
  - Control of discrete devices
  - Loop control
  - Sequential control using Equipment Modules
- Modification of existing PCSD-based control configuration
- PCSD methods for:
  - Module arbitration
  - Mode locking
  - Mode, state and failure propagation
  - Inter-module interfacing
  - Interlocks, permissive and force set points

**Audience:**

This course is designed for engineers and technicians who maintain a DeltaV system configured using the PMO Configuration Standards for DeltaV (PCSD) library.

**Prerequisites:**

Course 7009, DeltaV Implementation I and familiarity with process control

**DeltaV Power & Grounding for Electronic Systems – 5590  
CEUs – 1.4****Overview**

This course focuses on specific power and grounding requirements of a control system. You will learn:

- how to conduct site verifications
- how to audit using "hands-on" testing labs
- to detect power and grounding problems on existing sites

**Topics**

- Review of Power Basics
- Power System Measurements
- Low Voltage Power Systems
- Power System Grounding
- Earthing vs. Grounding
- Connection to Earth
- Equipment Grounding
- Code Requirements
- Building Power Distribution
- Feeders and Branch Circuits
- Separately Derived Systems
- Power & Grounding for the DeltaV System
- Single Point Grounding
- Isolated Ground Installations
- Dedicated Circuits
- DC Grounding
- Verifying New Installations
- Power Quality Problems
- Applying Power Conditioning
- SIS Power and Grounding Installation
- Intrinsic Safety Devices

**Audience**

This 2-day course is designed for personnel involved with the planning, installation and maintenance of DeltaV digital automation system and provides essential knowledge regarding the power and grounding system for DeltaV equipment.

**Prerequisites**

A working knowledge of electronics and AC power basics is required.

### DeltaV Safety Instrumented System with SLS 1508 Maintenance – 7303 CEUs – 2.1

#### Overview

This 3-day course is a hands-on instructor-led course. The course covers the architecture of the DeltaV SIS including Rosemount SIS instruments and Fisher™ SIS Digital Valve Controllers. Students will gain a working knowledge of the hardware and software allowing them to troubleshoot and maintain the system.

#### Topics

- Safety Lifecycle
- DeltaV SIS Overview
- DeltaV SLS1508 Hardware
- Safety Instrumented Functions
- Rosemount SIS Instruments
- AMS Device Manager
- Fisher™ SIS Digital Valve Controller
- SISNet Repeaters

#### Audience

This course is for Electrical & Instrument technicians, maintenance technicians, E&I/reliability engineers and other personnel responsible for maintaining a DeltaV SIS SLS 1508.

#### Prerequisites

Course 7018, DeltaV Hardware and Troubleshooting, is a requirement.

### DeltaV Batch Operations with PCSD using Live – 7474 CEUs – 2.1

#### Overview

This 3-day course (21 hrs.) uses lectures and hands-on workshops to train operators for batch process operation based on the ISA-88 Standard using generic DeltaV Live user interface with the PMO Configuration Standards for DeltaV (PCSD) library (for the DeltaV Live user interface, please select course 7074).

Students who complete this course will:

- Access operator main displays
- Manipulate various control parameters and operate the process
- Access faceplates and detail displays
- Understand process indications from graphics dynamos
- Monitor and acknowledge different alarm conditions
- Monitor process performance
- Create real-time and historical data charts
- Access historical data and event chronicle
- Understand basic batch terminology
- Manipulate Unit Module parameters
- Access different Batch Operator Interfaces
- Run recipe batches
- Review batch history data

For customized curriculum, designed around your site graphics and processes, please contact Educational Services (education@emerson.com).

#### Topics

- DeltaV Distributed Control System Overview
- DeltaV Operator Interface
- Operating Discrete and Analog Control Modules
- Operating Motor Control Modules
- Operating Regulatory and Cascade Control Modules
- Alarms and Events
- DeltaV Trending
- Unit Alarms
- Operating Equipment Modules
- DeltaV SIS
- Batch Process Simulation
- Batch Process Overview
- Operating Unit Modules
- Batch Operator Interface and/or DeltaV Live Batch Controls
- Procedures
- DeltaV Batch Historian
- DeltaV Campaign Manager

#### Prerequisites

None

#### Audience

This course is for operators, supervisors, and managers responsible for the operation of batch processes using the DeltaV Live user interface.

### DeltaV Batch Operations with PCSD using Live – Virtual - 7474V CEUs – 2.1



#### Overview

This 3-day course (21 hrs.) uses lectures and hands-on workshops to train operators for batch process operation based on the ISA-88 Standard using generic DeltaV Live user interface with the PMO Configuration Standards for DeltaV (PCSD) library (for the DeltaV Live user interface, please select course 7074).

Students who complete this course will:

- Access operator main displays
- Manipulate various control parameters and operate the process
- Access faceplates and detail displays
- Understand process indications from graphics dynamos
- Monitor and acknowledge different alarm conditions
- Monitor process performance
- Create real-time and historical data charts
- Access historical data and event chronicle
- Understand basic batch terminology
- Manipulate Unit Module parameters
- Access different Batch Operator Interfaces
- Run recipe batches
- Review batch history data

For customized curriculum, designed around your site graphics and processes, please contact Educational Services (education@emerson.com).

#### Topics

- DeltaV Distributed Control System Overview
- DeltaV Operator Interface
- Operating Discrete and Analog Control Modules
- Operating Motor Control Modules
- Operating Regulatory and Cascade Control Modules
- Alarms and Events
- DeltaV Trending
- Unit Alarms
- Operating Equipment Modules
- DeltaV SIS
- Batch Process Simulation
- Batch Process Overview
- Operating Unit Modules
- Batch Operator Interface and/or DeltaV Live Batch Controls
- Procedures
- DeltaV Batch Historian
- DeltaV Campaign Manager

#### Prerequisites

None

#### Audience

This course is for operators, supervisors, and managers responsible for the operation of batch processes using the DeltaV Live user interface.



### DeltaV Batch Operations with PCS D using Live – Blended – 7474B CEUs – 2.1

#### Overview

This 3-day course (21 hrs.) uses lectures and hands-on workshops to train operators for batch process operation based on the ISA-88 Standard using generic DeltaV Live user interface with the PMO Configuration Standards for DeltaV (PCSD) library (for the DeltaV Live user interface, please select course 7074).

Blended training provides the most flexibility in course scheduling. This is a self-paced training with courses available 24/7 on Emerson's Learning Management System (LMS). Blended courses are comprised of pre-recorded lectures and a cloud based DeltaV machine for workshop exercises using Standard generic DeltaV configuration.

Even though this is self-paced, ideally this course could be completed in 3 - days (21 hrs.)

Students who complete this course will:

- Access operator main displays
- Manipulate various control parameters and operate the process
- Access faceplates and detail displays
- Understand process indications from graphics dynamos
- Monitor and acknowledge different alarm conditions
- Monitor process performance
- Create real-time and historical data charts
- Access historical data and event chronicle
- Understand basic batch terminology
- Manipulate Unit Module parameters
- Access different Batch Operator Interfaces
- Run recipe batches
- Review batch history data

For customized curriculum, designed around your site graphics and processes, please contact Educational Services (education@emerson.com).

#### Topics

- DeltaV Distributed Control System Overview
- DeltaV Operator Interface
- Operating Discrete and Analog Control Modules
- Operating Motor Control Modules
- Operating Regulatory and Cascade Control Modules
- Alarms and Events
- DeltaV Trending
- Unit Alarms
- Operating Equipment Modules
- DeltaV SIS
- Batch Process Simulation
- Batch Process Overview
- Operating Unit Modules
- Batch Operator Interface and/or DeltaV Live Batch Controls
- Procedures
- DeltaV Batch Historian
- DeltaV Campaign Manager

### DeltaV SIS Implementation – 7305 CEUs – 3.2

#### Overview

This 4-1/2-day course is a hands-on instructor led course. The course covers complete DeltaV SIS Implementation including hardware and software architecture. Students will be able to design a DeltaV SIS Network and Safety Instrumented Functions (SIFs). Additionally, students will be able to configure smart SIS instruments and their associated alerts, including partial stroke testing.

#### Topics

- DeltaV SIS Overview
- DeltaV SIS SLS 1508 Hardware Architecture
- DeltaV SIS with Electronic Marshalling Hardware Architecture
- DeltaV Safety Instrumented Functions
- Rosemount SIS Instruments
- AMS Device Manager relating to DeltaV SIS
- Fisher™ SIS Digital Valve Controllers
- SISNet Repeaters
- DeltaV SIS Security
- DeltaV Version Control
- Local Safety Network Bridges

#### Audience

This course is for personnel who design, implement, commission and service DeltaV SIS.

#### Prerequisites

Course 7009 is a requirement. Recommend IEC 61511 knowledge.

### DeltaV SIS Implementation - Virtual - 7305V CEUs – 3.2



#### Overview

This 4-1/2-day course is a hands-on instructor led course. The course covers complete DeltaV SIS Implementation including hardware and software architecture. Students will be able to design a DeltaV SIS Network and Safety Instrumented Functions (SIFs). Additionally, students will be able to configure smart SIS instruments and their associated alerts, including partial stroke testing.

#### Topics

- DeltaV SIS Overview
- DeltaV SIS SLS 1508 Hardware Architecture
- DeltaV SIS with Electronic Marshalling Hardware Architecture
- DeltaV Safety Instrumented Functions
- Rosemount SIS Instruments
- AMS Device Manager relating to DeltaV SIS
- Fisher™ SIS Digital Valve Controllers
- SISNet Repeaters
- DeltaV SIS Security
- DeltaV Version Control
- Local Safety Network Bridges

### DeltaV SIS Overview – 7301 CEUs – 2.1

Contact the registration office for class information at education@emerson.com or 800-338-8158.

### DeltaV SIS with Electronic Marshalling Maintenance – 7304 CEUs – 2.1

#### Overview

This 3-day hands-on instructor led course covers the architecture of the DeltaV SIS with Electronic Marshalling including Rosemount SIS instruments and Fisher™ SIS Digital Valve Controllers. Students will be able to identify the DeltaV SIS with Electronic Marshalling hardware and software components. Students will practice troubleshooting and maintenance techniques with DeltaV SIS simulators throughout the course.

#### Topics

- Safety Lifecycle
- DeltaV SIS Overview
- DeltaV SIS with Electronic Marshalling Hardware architecture including power requirements
- Commissioning and Downloading the DeltaV SIS with Electronic Marshalling components
- Safety Instrumented Functions
- Rosemount SIS Instruments
- AMS Device Manager
- Fisher™ SIS Digital Valve Controller
- DeltaV Diagnostics
- DeltaV SIS with AMS Intelligent Device
- Local Safety Network Bridges

#### Audience

This course is for Electrical & Instrument technicians, maintenance technicians, E&I/reliability engineers and other personnel responsible for maintaining DeltaV SIS with Electronic Marshalling.

#### Prerequisites

Course 7018 DeltaV Hardware and Troubleshooting is a requirement.



### DeltaV Systems Batch Implementation – 7016

#### CEUs – 3.2

#### Overview

This 4-1/2-day course covers the implementation of a complete batch application. A process simulator will provide a batch application. Students will use DeltaV Batch software to configure recipe entities including, Aliasing, Equipment Trains, Dynamic Unit Allocation, Phase Logic, Operations and Unit Procedures. Equipment entities will also be configured including, Units modules and Process cells. This course includes access to a virtual DeltaV system to practice and review course workshops complete with brief recorded demonstrations available after course completion.

#### Topics

- Batch Overview
- Unit Phase
- Alias Definition
- Unit Module
- Process Cell
- Class Based Control Modules
- Class Based Equipment Modules
- Operation
- Unit Procedure
- Procedure
- Equipment Trains
- Unit Aliasing
- Dynamic Unit Allocation

#### Audience

This course is designed for individuals responsible for configuring and commissioning DeltaV Batch software.

#### Prerequisites

Course 7009, DeltaV Implementation I

### DeltaV Systems Batch Implementation - Virtual - 7016V

#### CEUs – 3.2



#### Overview

This 4-1/2-day course covers the implementation of a complete batch application. A process simulator will provide a batch application. Students will use DeltaV Batch software to configure recipe entities including, Aliasing, Equipment Trains, Dynamic Unit Allocation, Phase Logic, Operations and Unit Procedures. Equipment entities will also be configured including, Units modules and Process cells. This course includes access to a virtual DeltaV system to practice and review course workshops complete with brief recorded demonstrations available after course completion.

#### Topics

- Batch Overview
- Unit Phase
- Alias Definition
- Unit Module
- Process Cell
- Class Based Control Modules
- Class Based Equipment Modules
- Operation
- Unit Procedure
- Equipment Trains
- Unit Aliasing
- Dynamic Unit Allocation

### DeltaV Upgrade Course Synopsis - Virtual - 0301V



#### Overview

The 2-day DeltaV Upgrade advanced course focuses on the in-depth knowledge of DeltaV required to perform online upgrades or time constrained offline upgrades. Students will engage in learning the skills to be prepared handling several scenarios during DeltaV system upgrades. Students are required to take the Process University Course – DeltaV Upgrade 101 and be certified at the DeltaV Upgrade Associate level.

#### Topics

- Powerup Directory
- Cold Restart
- Redundant Controller Theory of Operation
- Redundant Application Station Theory of Operation
- Controller Upgrade Utility
- Domains
- System Analyzer tool
- Configuration issues
- Controller OS Differences
- Reversion Techniques
- Historian Upgrade Techniques
- Multi-Cast
- DCOM/App Station/Security/Integration
- Objectivity
- Batch Historian Upgrade Process
- When to say NO to perform an Online Upgrade

#### Audience

This course is designed for Internal Emerson and Local Business Partner engineers that will be involved in Performing Online Upgrades or Time Constrained Offline upgrades.

#### Prerequisites

- Professional Level Upgrade Certified

### DeltaV Operate Implementation I - Introduction- 7009 CEUs – 3.2

#### Overview

During the 4-1/2-day course, the student will be able to define system capabilities, define nodes, configure continuous and sequential control strategies, create process alarms, operate the system, troubleshoot the system and modify operator displays.

This course includes access to a virtual DeltaV system to practice and review course workshops complete with brief recorded demonstrations available after course completion.

#### Topics

- System Overview
- DeltaV Explorer
- DeltaV Diagnostics
- Control Modules
- Motor Control with Interlocking and Permissive Conditions
- Cascade Control
- Regulatory Control
- DeltaV Operate
- System Operation
- Alarms & Process History View
- Alarm Help
- Sequential Function Charts
- Configure Theme Dynamos
- Electronic Marshalling (CHARMS)

#### Audience

This course is designed for process & process control engineers responsible for obtaining key production data, maintaining, configuring and troubleshooting a DeltaV system.

#### Prerequisites

Microsoft Windows experience. Prospective attendees lacking process control experience should first attend Control Loop Foundation, Course 9025. Prospective attendees new to DeltaV should first attend PlantWeb/DeltaV Introduction, DeltaV Hardware & Troubleshooting, Course 7018.

### DeltaV Operate Implementation I - Introduction- Virtual - 7009V CEUs – 3.2



#### Overview

During the 4-1/2-day course, the student will be able to define system capabilities, define nodes, configure continuous and sequential control strategies, create process alarms, operate the system, troubleshoot the system and modify operator displays.

This course includes access to a virtual DeltaV system to practice and review course workshops complete with brief recorded demonstrations available after course completion.

#### Topics

- System Overview
- DeltaV Explorer
- DeltaV Diagnostics
- Control Modules
- Control Studio
- Motor Control with Interlocking and Permissive Conditions
- Cascade Control
- Regulatory Control
- DeltaV Operate
- System Operation
- Alarms & Process History View
- Alarm Help
- Sequential Function Charts
- Configure Theme Dynamos
- Electronic Marshalling (CHARMS)

#### Audience

This course is designed for process & process control engineers responsible for obtaining key production data, maintaining, configuring and troubleshooting a DeltaV system.

#### Prerequisites

Microsoft Windows experience. Prospective attendees lacking process control experience should first attend Control Loop Foundation, Course 9025. Prospective attendees new to DeltaV should first attend DeltaV Hardware & Troubleshooting, Course 7018.

### DeltaV Implementation using DeltaV Live – Introduction - 7409 CEUs – 3.2

#### Overview

During the 4-1/2-day course, the student will be able to define system capabilities, define nodes, configure continuous and sequential control strategies, create process alarms, operate the system, troubleshoot the system and modify operator displays using the DeltaV Live Operator Interface introduced with DeltaV Version 14.3.

This course includes access to a virtual DeltaV system to practice and review course workshops complete with brief recorded demonstrations available after course completion.

#### Topics

- System Overview
- DeltaV Explorer
- DeltaV Diagnostics
- Control Modules
- Control Studio
- Motor Control with Interlocking and Permissive Conditions
- Cascade Control
- Regulatory Control
- DeltaV Live
- Graphics Studio
- System Operation
- Alarms & Process History View
- Alarm Help
- Sequential Function Charts
- Configure Theme Dynamos
- Electronic Marshalling (CHARMS)

#### Audience

This course is designed for process & process control engineers responsible for obtaining key production data, maintaining, configuring and troubleshooting a DeltaV system.

#### Prerequisites

Microsoft Windows experience. Prospective attendees lacking process control experience should first attend Control Loop Foundation, Course 9025.

### DeltaV Implementation Using DeltaV Live – Introduction - Virtual - 7409V CEUs – 3.2

#### Overview



During the 4-1/2-day course, the student will be able to define system capabilities, define nodes, configure continuous and sequential control strategies, create process alarms, operate the system, troubleshoot the system and modify operator displays using the DeltaV Live Operator Interface introduced with DeltaV Version 14.3. This course includes access to a virtual DeltaV system to practice and review course workshops complete with brief recorded demonstrations available after course completion

#### Topics

- System Overview
- DeltaV Explorer
- DeltaV Diagnostics
- Control Modules
- Control Studio
- Motor Control with Interlocking and Permissive Conditions
- Cascade Control
- Regulatory Control
- DeltaV Live
- Graphics Studio
- System Operation
- Alarms & Process History View
- Alarm Help
- Sequential Function Charts
- Configure Theme Dynamos
- Electronic Marshalling (CHARMS)

#### Audience

This course is designed for process & process control engineers responsible for obtaining key production data, maintaining, configuring and troubleshooting a DeltaV system.

### DeltaV - Using DeltaV Live - Operator Training for Continuous Operation – 7412 CEUs 1.4

#### Overview

This 2-day course (14 hrs.) uses lectures and hands-on workshops to train operators for continuous process operation using the standard generic DeltaV Live user interface (for the DeltaV Operate user interface, please select course 7012).

Students who complete this course will:

- access operator main displays
- manipulate various control module operating parameters to operate the process
- access faceplates and detail displays
- understand process indications from graphic GEMs
- monitor and acknowledge different alarm conditions
- monitor process performance
- view real-time and historical trend data
- access historical data and event chronicle

Generic curriculum uses the out-of-the-box DeltaV configuration standards library. In most cases, the site configuration will differ from the generic library. After taking the generic course, students will be able to understand the basic layout of the graphics - e.g. the toolbar vs alarm banner, how to access the Alarm Summary page and acknowledge alarms, use of GEMs, where to click to access the Faceplate and Detail Displays, etc. This is considered “platform training” on DeltaV, not process training. For curriculum customized for your site please contact Educational Services for a proposal.

#### Topics

- DeltaV Distributed Control System Overview
- DeltaV Live Operator Interface
- Operating Discrete and Analog Control Modules
- Alarms and Events
- Operating Motor Control Modules
- Operating Regulatory and Cascade Control Modules
- DeltaV Trending
- Unit Alarms
- Operating Equipment Modules
- DeltaV SIS

#### Prerequisites

None

#### Audience

This course is for operators, supervisors and managers responsible for the operation of continuous processes using the DeltaV Live user interface.

### DeltaV - Using DeltaV Live - Operator Training for Continuous Operation – 7412V CEUs 1.4

#### Overview



This 2-day course (14 hrs.) uses lectures and hands-on workshops to train operators for continuous process operation using the standard generic DeltaV Live user interface (for the DeltaV Operate user interface, please select course 7012).

Students who complete this course will:

- access operator main displays
- manipulate various control module operating parameters to operate the process
- access faceplates and detail displays
- understand process indications from graphic GEMs
- monitor and acknowledge different alarm conditions
- monitor process performance
- view real-time and historical trend data
- access historical data and event chronicle

Generic curriculum uses the out-of-the-box DeltaV configuration standards library. In most cases, the site configuration will differ from the generic library. After taking the generic course, students will be able to understand the basic layout of the graphics - e.g. the toolbar vs alarm banner, how to access the Alarm Summary page and acknowledge alarms, use of GEMs, where to click to access the Faceplate and Detail Displays, etc. This is considered “platform training” on DeltaV, not process training. For curriculum customized for your site please contact Educational Services for a proposal.

#### Topics

- DeltaV Distributed Control System Overview
- DeltaV Live Operator Interface
- Operating Discrete and Analog Control Modules
- Alarms and Events
- Operating Motor Control Modules
- Operating Regulatory and Cascade Control Modules
- DeltaV Trending
- Unit Alarms
- Operating Equipment Modules
- DeltaV SIS

#### Prerequisites

None

#### Audience

This course is for operators, supervisors and managers responsible for the operation of continuous processes using the DeltaV Live user interface.

### DeltaV Virtualization – 7029 CEUs 3.2

#### Overview

This 4-1/2-day course focuses on the installation, configuration and system administration of a virtualized DeltaV distributed control system. Using a combination of lectures and workshops students will learn skill sets that enable them to properly plan, implement and maintain a robust DeltaV Virtual Studio (DVS) system intended for online (production) use. A key objective of this course is to prepare students for all aspects of owning a DVS system with special emphasis on providing highly available, reliable and secure access for end users of the DVS system.

#### Topics

- Virtualization Primer — Basics of How Virtualization Works
- Overview of DeltaV Virtualization Solutions
- Planning a DeltaV Virtual Studio System
- Installing and Configuring a VRTX Chassis and Blade Servers
- Creating DeltaV Virtual Machines including a ProfessionalPlus Node
- Configuring a WYSE or a Pepperl+Fuchs Thin Client and Redundant Thin Client Networks
- Create a Highly Available Failover Cluster
- Patching and Hardening of Cluster Nodes
- Cluster Health Monitoring and Troubleshooting
- Disaster Recovery and Replication
- Upgrading and Capacity Expansion

#### Audience

This course is designed for system administrators responsible for installing and maintaining DeltaV Workstations on a virtual platform.

#### Prerequisites

Course 7027, DeltaV Systems Administration for Windows 7 and Server 2008

### DeltaV Virtualization – Virtual - 7029V CEUs 3.2



#### Overview

This 4-1/2-day course focuses on the installation, configuration and system administration of a virtualized DeltaV distributed control system. Using a combination of lectures and workshops students will learn skill sets that enable them to properly plan, implement and maintain a robust DeltaV Virtual Studio (DVS) system intended for online (production) use. A key objective of this course is to prepare students for all aspects of owning a DVS system with special emphasis on providing highly available, reliable and secure access for end users of the DVS system.

#### Topics

- Virtualization Primer — Basics of How Virtualization Works
- Overview of DeltaV Virtualization Solutions
- Planning a DeltaV Virtual Studio System
- Installing and Configuring a VRTX Chassis and Blade Servers
- Creating DeltaV Virtual Machines including a ProfessionalPlus Node
- Configuring a WYSE or a Pepperl+Fuchs Thin Client and Redundant Thin Client Networks
- Create a Highly Available Failover Cluster
- Patching and Hardening of Cluster Nodes
- Cluster Health Monitoring and Troubleshooting
- Disaster Recovery and Replication
- Upgrading and Capacity Expansion

#### Audience

This course is designed for system administrators responsible for installing and maintaining DeltaV Workstations on a virtual platform.

#### Prerequisites

Course 7027, DeltaV Systems Administration for Windows 7 and Server 2008

### DeltaV Virtualization Administration – 7028 CEUs: 2.1

#### Overview

This 3-day DeltaV Virtualization course focuses on the various software that is used in the management of a DeltaV Virtualization environment. Students will engage in workshops that will reinforce the material discussed to successfully run and maintain a Virtualized DeltaV system.

#### Topics

##### Virtualization Hardware Setup

- Overview of a typical virtualization system
- Differences between a Host and DC Servers
- Role of a DC
- Networks within a virtualized system
- Clusters
- Virtual Networks

##### Virtual Machines

- Review Templates
- Process to create Virtual machines
- Overview of classroom setup
- Create additional DeltaV Workstations

##### DeltaV Virtual Studio Tools

- Grouping
- VM Modifications
- Edit Collection Settings

##### Thin Clients

- DeltaV Remote Desktop Connection (DRDC)
- Redundant Thin Client Networks

##### Replication & Disaster Recovery

- Install/Configure Replication
- Examine replication options
- Recover from failovers

##### Health Monitoring & Troubleshooting

- Emerson SHM
- DVS/Cluster Diagnostics
- DeltaV Alarming
- Failure Scenarios

##### Host Patching & Moving VMs

- Patching Procedures, Verification

#### Audience

This course is designed for system administration personnel that will be maintaining DeltaV workstations on a virtual platform after installation.

#### Prerequisites

7027 DeltaV System Administration

### DeltaV Virtualization Administration – Virtual - 7028V

CEUs: 2.1



#### Overview

This 3-day DeltaV Virtualization course focuses on the various software that is used in the management of a DeltaV Virtualization environment. Students will engage in workshops that will reinforce the material discussed to successfully run and maintain a Virtualized DeltaV system.

#### Topics

##### Virtualization Hardware Setup

- Overview of a typical virtualization system
- Differences between a Host and DC Servers
- Role of a DC
- Networks within a virtualized system
- Clusters
- Virtual Networks

##### Virtual Machines

- Review Templates
- Process to create Virtual machines
- Overview of classroom setup
- Create additional DeltaV Workstations

##### DeltaV Virtual Studio Tools

- Grouping
- VM Modifications
- Edit Collection Settings

##### Thin Clients

- DeltaV Remote Desktop Connection (DRDC)
- Redundant Thin Client Networks

##### Replication & Disaster Recovery

- Install/Configure Replication
- Examine replication options
- Recover from failovers

##### Health Monitoring & Troubleshooting

- Emerson SHM
- DVS/Cluster Diagnostics
- DeltaV Alarming
- Failure Scenarios

##### Host Patching & Moving VMs

- Patching Procedures, Verification

#### Audience

This course is designed for system administration personnel that will be maintaining DeltaV workstations on a virtual platform after installation.

#### Prerequisites

7027 DeltaV System Administration

### DeltaV Batch Operation Using Live – 7414

CEUs: 1.8

#### Overview

This 2½ - day course (18 hrs.) uses lectures and hands-on workshops to train operators for batch process operation based on the ISA-88 Standard using the standard DeltaV Live user interface (for the DeltaV Operate user interface, please select course 7014).

Students who complete this course will:

- Access operator main displays
- Manipulate various control module operating parameters to operate the process
- Access faceplates and detail displays
- Understand process indications from graphic GEMs
- Monitor and acknowledge different alarm conditions
- Monitor process performance
- View real-time and historical trend data
- Access historical data and event chronicle
- Understand basic batch terminology
- Manipulate Unit Module parameters
- Access different Batch Operator Interfaces
- Run recipe batches
- Review batch history data

Generic curriculum uses the out-of-the-box DeltaV configuration standards library. In most cases, the site configuration will differ from the generic library. After taking the generic course, students will be able to understand the basic layout of the graphics - e.g. the toolbar vs alarm banner, how to access the Alarm Summary page and acknowledge alarms, use of GEMs, where to click to access the Faceplate and Detail Displays, etc. This is considered “platform training” on DeltaV, not process training. For curriculum customized for your site please contact Educational Services for a proposal.

#### Topics

- DeltaV Distributed Control System Overview
- DeltaV Live Operator Interface
- Display Navigation
- Operating Discrete and Analog Control Modules
- Operating Motor Control Modules
- Operating Regulatory and Cascade Control Modules
- Alarms and Events
- DeltaV Trending
- Unit Alarms
- Operating Equipment Modules
- DeltaV SIS

### 7414 – Continued...

- Batch Process Simulation
- Batch Process Overview
- Operating Unit Modules
- Batch Operator Interface and/or DeltaV Live Batch Controls
- Procedures
- DeltaV Batch Historian
- DeltaV Campaign Manager

#### Prerequisites

None

#### Audience

This course is for operators, supervisors, and managers responsible for the operation of batch processes using the DeltaV Live user interface.

### DeltaV Batch Operation Using Live – Virtual - 7414V

CEUs: 1.8



#### Overview

This 2½ - day course (18 hrs.) uses lectures and hands-on workshops to train operators for batch process operation based on the ISA-88 Standard using the standard DeltaV Live user interface (for the DeltaV Operate user interface, please select course 7014).

Students who complete this course will:

- Access operator main displays
- Manipulate various control module operating parameters to operate the process
- Access faceplates and detail displays
- Understand process indications from graphic GEMs
- Monitor and acknowledge different alarm conditions
- Monitor process performance
- View real-time and historical trend data
- Access historical data and event chronicle
- Understand basic batch terminology
- Manipulate Unit Module parameters
- Access different Batch Operator Interfaces
- Run recipe batches
- Review batch history data

Generic curriculum uses the out-of-the-box DeltaV configuration standards library. In most cases, the site configuration will differ from the generic library. After taking the generic course, students will be able to understand the basic layout of the graphics - e.g. the toolbar vs alarm banner, how to access the Alarm Summary page and acknowledge alarms, use of GEMs, where to click to access the Faceplate and Detail Displays, etc. This is considered “platform training” on DeltaV, not process training. For curriculum customized for your site



**7414V – Continued...**

please contact Educational Services for a proposal.

**Topics**

- DeltaV Distributed Control System Overview
- DeltaV Live Operator Interface
- Display Navigation
- Operating Discrete and Analog Control Modules
- Operating Motor Control Modules
- Operating Regulatory and Cascade Control Modules
- Alarms and Events
- DeltaV Trending
- Unit Alarms
- Operating Equipment Modules
- DeltaV SIS
- Batch Process Simulation
- Batch Process Overview
- Operating Unit Modules
- Batch Operator Interface and/or DeltaV Live Batch Controls
- Procedures
- DeltaV Batch Historian
- DeltaV Campaign Manager

**DeltaV New Features – 7999**

**CEU'S: 1.4**

**Overview**

This 2.0-day course covers the new features and enhancements made to the DeltaV Distributed Control System in v13 and v14 using a combination of lectures, demos and hands-on workshop exercises. Students who complete the course will:

- Understand the new features and enhancements introduced in DeltaV v13 and v14
- Understand the benefits of the new features
- Understand how to apply the new features
- Perform workshop exercises implementing the new features

**Topics**

The course includes 40 core topics and 32 optional topics categorized under the following functional areas:

- Administration
- Alarm Management
- Batch
- Hardware
- Logic Configuration
- Miscellaneous
- Operator Interface
- Security
- SIS

The 40 core topics require 2 days to complete. The course may be customized based on the individual site's topics of

**7999 – Continued...**

interest. For customized course delivery, the course duration will be determined based on the topics to be included or excluded.

**Audience**

This course is intended for plant personnel responsible for configuring, administering, securing, maintaining and operating DeltaV. This includes control system engineers, administrators, maintenance engineers and technicians.

**Prerequisites**

Course # 7009, 7409 or 7018

**DeltaV Standalone PK Controller – 7400**

**CEUs: 0.7**

**Overview**

This 1-day course provides lectures and hands-on workshops about PK controller, its hardware components and administration for a standalone application.

**Topics**

- Benefits of PK Controller
- Sizing PK Controller
- PK Controller Capacity and Specifications
- PK Hardware Components
- Installing PK Hardware Components
- PK Controller Administration
- PK Controller Commissioning
- PK Controller Lock and Unlock Functions
- PK Merge Utility

**Audience**

This course is designed for engineers and technicians responsible for installing and maintaining PK controller standalone application.

**Prerequisite**

Windows experience and DeltaV configuration background.

**DeltaV Standalone PK Controller – 7400**

**CEUs: 0.7**

**Overview**

This 1-day course provides lectures and hands-on workshops about PK controller, its hardware components and administration for a standalone application.

**Topics**

- Benefits of PK Controller
- Sizing PK Controller
- PK Controller Capacity and Specifications
- PK Hardware Components
- Installing PK Hardware Components
- PK Controller Administration
- PK Controller Commissioning
- PK Controller Lock and Unlock Functions
- PK Merge Utility





### EnTech Toolkit – 1430 CEUs – 2.1

#### Overview

This is a 3-day course that fully explores the various functions, options and capabilities that are built into the EnTech Toolkit software. The course starts with the data acquisition features of the Collect module as it is connected to field instrumentation or directly to digital systems. The power of the Analyses time series analysis software for process trouble-shooting, auditing and reporting on performance is examined using process simulators. The Tuner module includes bump test analysis, calculation of controller tuning parameters, and simulation of controller response characteristics. Participants are asked to perform process audits and report on their findings and the improvements they make.

#### Audience

This course is for engineers, technicians or other persons who have responsibility for using the EnTech Toolkit as part of their role in process troubleshooting, minimizing variability, and improving or maintaining performance of operations.

### EnTech Process Dynamics & Tuning – Introduction - 9030 CEUs – 2.8

#### Overview

EnTech Process Dynamics, Control and Tuning Fundamentals (Process Control for Engineers I) is a 4-day course that provides the fundamental theory governing process dynamic behavior, control system operation and controller tuning. Course material is based on experience gained in process variability optimization work and is based on modern control engineering concepts coupled with practical process application knowledge. This course presents a systematic approach to optimizing the control of a process unit operation in order to manufacture uniform product more efficiently. The course uses formal lectures with hands-on lab exercises. High fidelity process simulators are used as the basis for the labs and simulation analysis.

#### Topics

- **Process Dynamics - Self Regulating and Integrating process**
- **Identify Process Model parameters – process gain, process deadtime and process time constant**
- **Develop simple linear transfer function dynamic models of 1<sup>st</sup> Order, 2<sup>nd</sup> Order and Integrating process**
- **Examine various sources of nonlinearity arising from equipment, instrumentation (valves) and process itself**
- **Control resolution and valve non-linearity**
- **Mathematical models of PID controller – PID forms, structures and tuning parameters**
- **Tuning methods – from Ziegler Nichols (quarter amplitude dampening), to Cohen-Coons (reactive curve) to Lambda tuning (Internal Model Control)**

- **Self-regulating process dynamics – tuning 1<sup>st</sup> Order and 2<sup>nd</sup> Order process loops**
- **Stability analysis – root locus, gain margin and phase margin analysis**
- **Frequency analysis – evaluate dynamic system performance, bode plots and minimum variance control**
- **Closed loop setpoint and load response**
- **Integrating process dynamics – tuning level controls**
- **Interactive Control Loops – decoupling control**
- **Coordinated Lambda Tuning for Unit Optimization**
- **Control Loop Tuning using EnTech Toolkit Tuner module – Lambda tuning**
- **Simulator Labs – high fidelity simulator exercises engage students in Lambda tuning analysis**

#### Audience

This course is for engineers, or persons with equivalent math and theoretical background, who have responsibility for process control design and implementation, process optimization or process design and troubleshooting.

#### Prerequisite

An engineering degree or equivalent knowledge and functionality in the mathematics required to understand the concepts listed in "topics".

### EnTech Applied Modern Loop – 9032 - CEUs – 2.1

#### Overview

Applied Modern Loop Tuning (9032) is a 3-day registration or on-site course that introduces participants to effective methods for determining optimal tuning parameters for regulation of processes. The non-oscillatory EnTech tuning techniques, based on Lambda tuning concepts, are taught with a focus on minimizing process variability. Effectiveness is gained by the implementation of a tuning strategy that matches control loop dynamics to process operating requirements. It contains formal lectures that are amply populated with process examples and supported with hands-on lab exercises using high-fidelity process simulator software. Participants learn how to recognize acceptable versus unacceptable control loop performance and to identify the most common source of problems. Fundamental tuning concepts, including the PID controller, process dynamics, valve motion characteristics dead band (backlash) and resolution (stick/slip), set point tracking and regulatory control, integrating processes, and level control are reviewed and demonstrated using case study examples.

#### Topics

- Process Dynamics and Process Model Identification
- Open loop and Closed Loop Bump Tests Process Response — 1st and 2nd Order Self-Regulating Process and Integrating Process
- Process Model — Process Gain, Process Dead time and Process Time Constant
- Control Resolution and Valve Non-Linearity

- PID Forms and Structures
- Tuning Methods — Ziegler Nichols (QAD) and Model Based Lambda Tuning
- Self-Regulating process - Closed Loop Set point and Load Response Tuning
- Process variable Signal Filtering Integrating Process — Closed Loop Set point and Load Response Tuning
- Cascade Control Tuning
- Interactive Control Loops — Decoupling Control
- High-Fidelity Process Simulator Software - Engage Students in Hands-On Learning

#### Audience

This course is for engineers and technicians responsible for maintaining process control performance using instrumentation and control loop tuning.

#### Prerequisite

Some experience with process instrumentation and control is helpful.

### EnTech Applied Regulatory Controls - Advanced – 9034

#### CEUs – 2.1

#### Overview

EnTech Applied Advanced Regulatory Controls (9034) is a 3-day course that teaches the practical principals of advanced regulatory controls and tuning techniques to achieve improvements that can exceed that of basic PID controls.

The course will examine many advanced regulatory control technologies commonly available today and help participants understand which technologies are best suited and how to appropriately apply them given specific process dynamics and conditions.

Formal lectures are amply populated with process examples and supported with hands-on lab exercises. Approximately 40% of the course is hands-on lab based workshops where students develop practical skills required to apply and tune advanced regulatory controls. A dynamic process simulator is used to simulate a variety of process unit dynamics and evaluate the benefits of different advanced regulatory control strategies.

#### Topics

- Process and Disturbance Dynamics
- PID Algorithms – PID, PI, PI-D, I-PD, PD, P-D, ID, I-D, 2 degrees of freedom control
- Cascade Control, Dynamic Feedforward
- Ratio Control, Override (selector) Control
- Split Range and Midrange Control
- Interactive Control Loops – Decoupling Control (2X2) and Lambda Tuning
- Deadtime Compensation (Smith Predictor)
- Adaptive Control (Gain Scheduling, Auto Tuning)
- Introduction to Model Predictive Control (Multiple Inputs Single Output)

#### Audience

This course is for engineers and technicians responsible for process control design, implementation, and control performance.

#### Prerequisite

Participants should possess basic process control knowledge

### EnTech Process Analysis & Minimizing Variability – 9031

CEUs – 2.8

#### Overview

EnTech Process Analysis and Minimizing Variability (9031 Process Control for Engineers II) is a 4-day course that provides knowledge of the techniques used to troubleshoot process and control problems, improve performance and reduce variability in processes. Time series analysis, including power spectrum and auto/cross correlation functions, are presented as tools for process and control performance evaluation. The course uses formal lectures that are highlighted with an ample repertoire of process examples and hands-on lab exercises. High fidelity process simulators are used as the basis for the labs and situation analyses.

#### Topics

- Review - topics presented in 9030 Process Dynamics, Control and Tuning Fundamentals
- Use of EnTech Toolkit Tuner module for Identification of Process Dynamics, Lambda Tuning, Time Series Analysis
- Controller Tuning Troubleshooting - Dynamic Loop Interaction Problems
- Digital Control - Digital Controllers and Digital Sensors
- Signal Quantization, Signal Aliasing and Signal Filtering
- Time Series Analysis – process variability analysis
- Frequency Analysis - Power Spectrum analysis
- Auto and Cross Correlation Analysis – minimum variance control
- Interpreting Plant Process Data
- Process and Control Auditing Techniques
- Control Loop Evaluation using EnTech Toolkit Analyse module - Power Spectrum and Correlation analysis
- Integrated Process and Control Design
- Advanced Process Control
- Simulator Labs – high fidelity simulator exercises engage students in Lambda tuning analysis and Control Loop Performance Investigation

#### Audience

This course is for engineers, or persons with equivalent math and theoretical background, who have responsibility for process control design and implementation, process optimization, instrumentation engineering, or process design and troubleshooting.

#### Prerequisite

Participants should have taken 9030 Process Dynamics, Control and Tuning Fundamentals (Process Control for Engineers I) or have similar knowledge.

### EnTech Applied Modern Loop & Advanced Regulatory Controls – 9035

CEUs – 2.8

#### Overview

This is a special combined 9032 and 9034 4-day course that teaches the practical principals of advanced regulatory controls and tuning techniques to achieve improvements that can exceed that of basic PID controls.

The course will examine many advanced regulatory control technologies commonly available today and help participants understand which technologies are best suited and how to appropriately apply them given specific process dynamics and conditions.

Formal lectures are amply populated with process examples and supported with hands-on lab exercises. Approximately 40% of the course is hands-on lab based workshops where students develop practical skills required to apply and tune advanced regulatory controls. A dynamic process simulator is used to simulate a variety of process unit dynamics and evaluate the benefits of different advanced regulatory control strategies.

#### Topics

- Process Dynamics and Process Model Identification
- Open loop and Closed loop bump tests
- Process Response – 1<sup>st</sup> and 2<sup>nd</sup> order self-regulating process and integrating process
- Process Model – process gain, process deadtime and process time constant
- Control resolution and valve non-linearity
- PID forms and structures
- Tuning Methods – Ziegler Nichols (quarter amplitude dampening) & model based Lambda Tuning
- Self-Regulating process - Closed loop setpoint and load response tuning
- Process variable signal filtering
- Integrating process – Closed loop setpoint and load response tuning
- Cascade control tuning
- Interactive control loops – decoupling control
- Dynamic Feedforward control – identification of process dynamics and feedforward tuning
- Deadtime Compensator – Smith Predictor deadtime compensator control versus PID
- PID Algorithms – PID, PI, PI-D, I-PD, PD, P-D, ID, I-D, 2 degrees of freedom control
- Simulator Labs – high fidelity simulator exercises engage students in Lambda tuning analysis

#### Audience

This course is for engineers and technicians responsible for process control

design, implementation, and control performance.

#### Prerequisite

Participants should possess basic process control knowledge

### EnTech Process Troubleshooting & Optimization – 9036

CEUs – 2.8

#### Overview

This 4-day course starts with the tools and techniques that were developed in 9032 but applies them to a methodical approach to process troubleshooting. The focus is on process variability: what it is, how it is measured, how it propagates through the process, how it can be identified and how it can be reduced. The tools available on the DCS as well as specialized tools (EnTech Toolkit) are studied to see how they help in identifying sources of process variability and the components of process improvement programs (Process design, control equipment design, control strategy design and tuning design) are studied in context of the process objectives. The focus is on process variability: what it is, how it is measured, how it propagates through the process, how it can be identified and how it can be reduced. The tools available on the DCS as well as specialized tools (EnTech Toolkit) are studied to see how they help in identifying sources of process variability and the components of process improvement programs (Process design, control equipment design, control strategy design and tuning design) are studied in context of the process objectives.

#### Topics

- Review of Process Dynamics
- Review of Feedback Control and PID Controllers
- Properties of Process and Product Variability
- Tools to measure Process variability
- Reducing variability through process control
- Dealing with non-linearities
- Troubleshooting using trends, statistics, auto / manual runs and bump tests
- Troubleshoot using Power Spectrum and Cross Correlation and EnTech's Analyse Process Objectives
- Reducing variability by process design and by tuning strategy
- Reducing Variability by Control element design
- Reducing Variability by Control strategy design

#### Audience

This course is for engineers and technicians who are process control or control performance specialists  
Prerequisite: 9032- EnTech Applied Modern Loop Tuning

#### Prerequisite

Participants should have an understanding of instrumentation and basic knowledge of process control.

Fisher™ Valve Learning Path

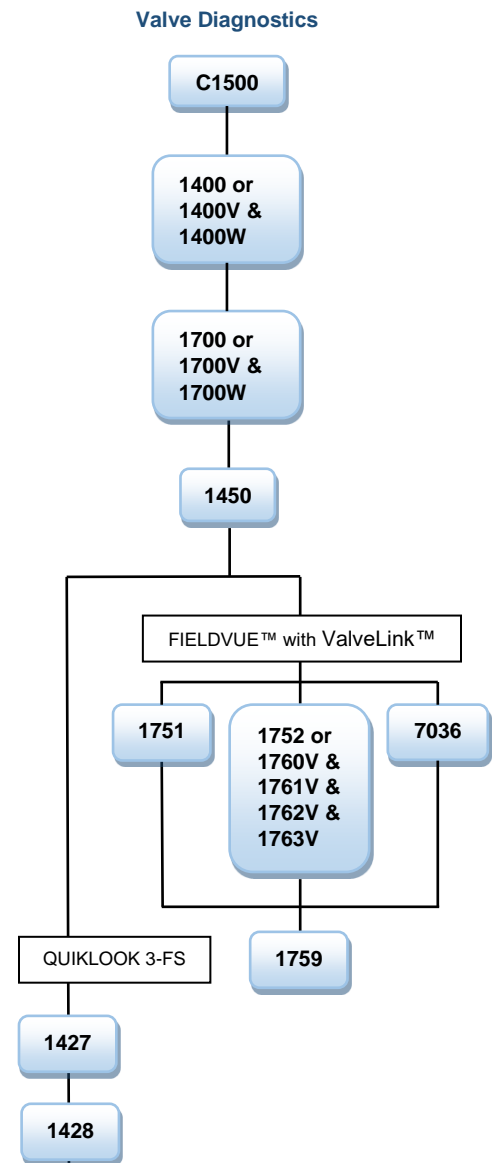
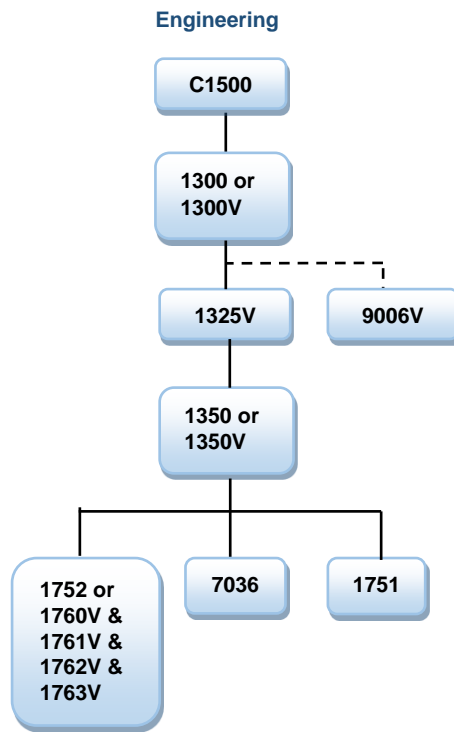
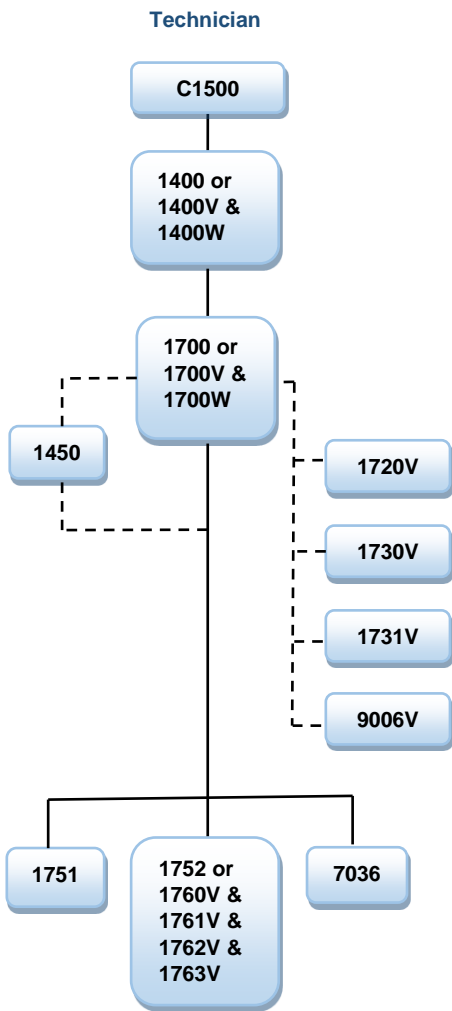

### Fisher Control Valve - Introduction - e1500 CEUs - .4



#### Overview

This curriculum contains e1500, e1501, e1502, and e1503 - the course group introduces the basic terminology of control devices: including control valve types, uses, roles, flow characteristics and to the various entities that define codes and standards for control devices. Sliding stem, rotary, and the basics of an actuator, lists the types of actuators for sliding stem and rotary control valves, states the general components of an actuator and lists general actuator selection guidelines.

### Fisher Control Valve – Introduction e1500 CEU's - .1



#### Overview

This course introduces the basic terminology of control devices: including control valves types, uses, roles, flow characteristics and the various entities that define codes and standards for control devices.

### Fisher Sliding Stem Control Valve - Introduction - e1501 CEUs - .1



#### Overview

This course introduces the basic definition of sliding stem control valves, types of sliding stem valves, their common components, guiding methods, typical uses, flow characteristics, the general sizing capacity and selection guidelines.

### Fisher Rotary Control Valve - Introduction - e1502 CEUs - .1



#### Overview

This course introduces the basic definition of rotary control valves, defines the body types and styles of rotary valves, as well as their common components, flow characteristics and considerations, and finally the general sizing capacity and selection guidelines.

### Fisher Actuator - Introduction - e1503



#### Overview

This course introduces the basic definition of an actuator, lists the types of actuators for sliding stem and rotary control valves, states the general components of an actuator and lists the general actuator selection guidelines.

### Fisher Control Valve Engineering I – Introduction - 1300 CEUs – 2.1

#### Overview

This 3-day course reviews design and operating principles of control valves, actuators, positioners and related accessories. It describes the sizing and selection methods for a broad variety of control valves assemblies. Students will solve several demonstration sizing and selection problems using Fisher Specification Manager software and published materials, plus participate in equipment demonstrations and hands-on workshops. Students who complete this course will:

- Select the proper valve characteristic for a given process
- Choose suitable styles of control valves for an application
- Size control valves and actuators
- Properly apply positioners and instruments

#### Topics

- Control valve selection: rotary/sliding stem
- Actuator selection and sizing
- Liquid valve sizing
- Gas valve sizing
- Positioners and transducers
- Valve guidelines
- Valve characteristics
- Valve packing considerations

#### Delivery Options

This training is also available as a remote virtual classroom course 1300V.

#### Audience

This course is for engineers, technicians and others responsible for the selection, sizing, and application of control valves, actuators and control valve instrumentation.

#### Prerequisites

Some experience with industrial control equipment including control valves and actuators would be helpful.

### Fisher Control Valve Engineering – Introduction – Virtual - 1300V CEUs – 1.6



#### Overview

This 16-hour remote virtual classroom course event consists of 4 virtual classroom parts, 4 hours for each part. It reviews design and operating principles of control valves, actuators, positioners and related accessories. It describes the sizing and selection methods for a broad variety of control valves assemblies. Students will solve several demonstration sizing and selection problems using Fisher Specification Manager software and published materials. Students who complete this course will:

- Select the proper valve characteristic for a given process
- Choose suitable styles of control valves for an application
- Size control valves and actuators
- Properly apply positioners and instruments

#### Topics

- Control valve selection: rotary/sliding stem
- Actuator selection and sizing
- Liquid valve sizing
- Gas valve sizing
- Positioners and transducers
- Valve guidelines
- Valve characteristics
- Valve packing considerations

#### Delivery Options

This training is also available as an Instructor Led course 1300.

#### Audience

This course is specifically tailored to technicians, engineers and others responsible for the proper selection, sizing, and application of control valve assemblies.

#### Prerequisites

Some experience with industrial control equipment including control valves and actuators would be helpful.

### Fisher Control Valve Engineering – Intermediate - 1325V CEUs - .8



#### Overview

This 8-hour remote virtual classroom course event consists of 2 virtual classroom part, 4 hours for each part. It reviews design and operating principles of control valves in various applications. It describes the sizing and selection methods utilized in selecting appropriate control valve assemblies, as they relate to severe service applications such as noise and cavitation. Students will solve several advanced sizing and selection problems using Fisher Specification Manager software and published materials. Students will also have the opportunity to ask Emerson certified instructors for Fisher engineering courses to clarify questions and assist in better understanding of these advanced fluid mechanics ideas. Students who successfully complete this course will:

- Size control valves and trim for a cavitating application
- Size control valves and trim for a noisy application
- Choose suitable styles of control valves for an application
- Size control valves for an erosive and/or corrosive application
- Properly apply knowledge learned from 1300 or 1300V

#### Topics

- Cavitation and flashing
- Noise
- Corrosion
- Erosion
- Valve application guidelines

#### Audience

This course is designed for engineers, technicians and others responsible for the selection, sizing, and application of control valve assemblies.

#### Prerequisites

Successful completion of 1300V or 1300 is required. Familiarity with sizing, selection, and advanced applications of control valves is strongly encouraged.

### Fisher Control Valve Engineering – Advanced - 1350 CEUs – 2.1

#### Overview

This 3-day course reviews advanced application-specific design and operating principles of control valve assemblies, instruments, and accessories installed in a variety of non-general service applications. Students will gain insight in sizing and selection methods utilized in selecting appropriate control valve assemblies, as they relate to advanced control topics. Fisher Specification Manager software, combined with published reference materials, will be used to solve several advanced sizing and selection problems. Students will also have the opportunity to ask Emerson certified Fisher engineering instructors clarifying questions to firmly understand the advanced fluid mechanics covered in this course. Students who successfully complete the course will:

- Properly apply knowledge learned from 1300/1300V and 1325V
- Review basic sizing of control valves and build on the complexity of applications
- Review basics of thermodynamics and how those concepts relate to the sizing model
- Discuss key ideas involving cryogenic control valve assembly applications
- Size and select control valves for two-phase flow of hydrocarbon mixtures and dissolved gas
- Size and select actuators and pneumatic accessories for stroking speed requirements
- Gain insight into instrument diagnostics and optimum loop performance
- Learn the basics of steam conditioning processes and associated equipment

#### Topics

- Cavitation and flashing
- Noise
- Basic thermodynamics
- Cryogenic valves
- Two-phase flow
- Stroking speed
- Steam conditioning
- Control valve optimum loop performance
- Control Valve Diagnostic Basics

#### Delivery Options

This training is also available as a remote virtual classroom course 1350V.

#### Audience

This course is specifically tailored to technicians, engineers and others responsible for the proper selection, sizing, and application of control valve assemblies.

#### Prerequisites

Successful completion of 1300 or 1300V and 1325V is required. Familiarity with sizing, selection, and advanced application of control valves is strongly encouraged.

### Fisher Control Valve Engineering – Advanced – Virtual - 1350V CEUs – 1.6



#### Overview

This 16-hour remote virtual classroom course event consists of 4 virtual class room, 4-hour for each part. It reviews advanced application-specific design and operating principles of control valve assemblies, instruments, and accessories installed in a variety of non-general service applications.

Students will gain insight in sizing and selection methods utilized in selecting appropriate control valve assemblies, as they relate to advanced control topics. Fisher Specification Manager software, combined with published reference materials, will be used to solve several advanced sizing and selection problems. Students will also have the opportunity to ask Emerson certified Fisher engineering instructors clarifying questions to firmly understand the advanced fluid mechanics covered in this course. Students who successfully complete the course will:

- Properly apply knowledge learned from 1300 or 1300V and 1325
- Review basic sizing of control valves and build on the complexity of applications
- Review basics of thermodynamics and how those concepts relate to the sizing model
- Discuss key ideas involving cryogenic control valve assembly applications
- Size and select control valves for two-phase flow of hydrocarbon mixtures and dissolved gas
- Size and select actuators and pneumatic accessories for stroking speed requirements
- Gain insight into instrument diagnostics and optimum loop performance
- Learn the basics of steam conditioning processes and associated equipment

#### Topics

- Cavitation and flashing
- Noise
- Basic thermodynamics
- Cryogenic valves
- Two-phase flow
- Stroking speed
- Steam conditioning
- Control valve optimum loop performance
- Control Valve Diagnostic Basics



### Fisher Control Valve Engineering – Advanced - 1350V – Continued...

#### Delivery Options

This training is also available as an Instructor Led course 1350.

#### Audience

It is specifically tailored to technicians, engineers and others responsible for the proper selection, sizing, and application of control valve assemblies.

#### Prerequisites

Successful completion of 1300 or 1300V and 1325V is required. Familiarity with sizing, selection, and advanced application of control valves is strongly encouraged.

### Fisher Valve Trim & Body Maintenance - 1400 CEUs – 2.1

#### Overview

This 3-day course and hands-on workshop explains how valves and actuators function and how they are installed and calibrated. It emphasizes installation, troubleshooting, parts replacement, and calibration of control valves, actuators, and FIELDVUE™ digital valve controllers. Those who complete this course will be able to:

- Correctly perform installation procedures
- Perform basic troubleshooting
- Properly apply and calibrate Fisher FIELDVUE DVC6200 digital valve controllers
- Change valve trim, gaskets and packing

#### Topics

- Control valve terminology
- Globe valves
- Packing
- Actuators, and digital valve controllers
- Bench set
- Seat leak testing
- Ball valves
- Butterfly valves
- Eccentric disc valves
- Valve characteristics

#### Delivery Options

This training is also available as a remote virtual classroom course 1400V.

#### Audience

This introductory course is for valve mechanics, maintenance personnel, instrument technicians, and others who are responsible for maintaining control valves, actuators and control valve instrumentation.

#### Prerequisites

Some experience in instrument calibration and in control valve maintenance, installation, and operation would be helpful.

### Fisher Valve Trim & Body Maintenance – Virtual - 1400V CEUs – 1.6



#### Overview

This 16-hour remote virtual classroom course event consists of 4 virtual classroom parts, 4 hours for each part. It explains how valves and actuators function and how they are installed and calibrated. It emphasizes installation, troubleshooting, parts replacement, and calibration of control valves, actuators, and FIELDVUE™ digital valve controllers.

#### Topics

- Control valve terminology
- Globe valves
- Packing
- Actuators, and digital valve controllers
- Bench set
- Seat leak testing
- Ball valves
- Butterfly valves
- Eccentric disc valves

#### Delivery Options

This training is also available as an Instructor Led course 1400.

#### Audience

This introductory course is for valve mechanics, maintenance personnel, instrument technicians, and others who are responsible for maintaining control valves, actuators and control valve instrumentation.

#### Prerequisites

Some experience in instrument calibration and in control valve maintenance, installation, and operation would be helpful.

### Fisher Valve Body & Trim Maintenance - Workshop– 1400V CEUs – .8

#### Overview

This 8-hour workshop is offered as an optional component following the 1400V remote virtual classroom event. Students will have the opportunity to perform hands on exercises on control valve bodies and actuators that reinforce the maintenance topics that were discussed during the online portion of the course. The workshop is hosted in Marshalltown, IA and a workshop facilitator will be present to assist the students with any questions they may have while performing the exercises.

#### Workshops

- Fisher easy-e™ - valve trim maintenance and repair
- Fisher sliding stem valve packing replacement
- Fisher Sliding stem actuator maintenance and repair
- Fisher 657 and 667 actuator bench set
- Fisher butterfly valve maintenance and repair
- Fisher ball valve maintenance and repair
- Fisher eccentric plug valve maintenance and repair
- Fisher rotary shaft valve packing replacement
- Fisher rotary actuator maintenance and repair
- Fisher rotary valve and actuator mounting

#### Audience

This workshop is intended for any students that have completed the online component of the 1400V course and would like to gain some hands-on experience working with the control valve assemblies.

#### Prerequisites

Must have successfully completed the 1400V course.



### Baumann Valves & Actuators Implementation - 1402 CEUs – 2.1

#### Overview

This 3-day course and hands-on workshop explains how Baumann™ valves and actuators function and how they are installed and calibrated. It emphasizes installation, troubleshooting, parts replacement, and calibration of control valves, actuators, positioners and FIELDVUE™ digital valve controllers. Those who complete this course will be able to:

- Correctly perform installation procedures
- Perform basic troubleshooting
- Properly apply and calibrate positioners and Fisher FIELDVUE digital valve controllers
- Change valve trim, gaskets and packing
- Properly adjust sanitary valves

#### Topics

- 24000 general service valves
- Sanitary valves
- Low flow and specialty valves
- Packing
- Bench range
- Seat leak testing
- Actuators
- Positioners and FIELDVUE digital valve controllers

#### Prerequisites

Some experience in instrument calibration and in control valve maintenance, installation, and operation would be helpful.

### Fisher Nuclear Data Acquisition & Interpretation - Introduction – 1427 CEUs – 2.8

#### Overview

This 4 1/2-day course uses lecture and hands-on labs to teach students to properly set up and acquire diagnostic data using the QUIKLOOK 3-FS or FlowScanner 6000 valve diagnostic system. This course teaches proper setup of hardware and software, accurate entry of data, and other procedures that are required to ensure accuracy when acquiring data. Also covered are some basics in interpreting and analyzing the collected data. Students will properly connect to and test a sampling of valves including sliding stem and rotary as well as spring and diaphragm and piston options. Students who complete this will:

- Navigate features of QUIKLOOK 3-FS or FlowScanner 6000 software
- Correctly mount sensors and related QUIKLOOK 3-FS or FlowScanner 6000 hardware on standard air-operated valves (AOV's)
- Enter valve, instrument, and actuator data
- Correctly enter test parameters
- Perform various step and stroking tests to collect diagnostic data
- Analyze typical and atypical, graph data
- Create/view reports

#### Topics

- QUIKLOOK 3-FS or FlowScanner 6000 valve diagnostic system hardware/software overview
- In-depth software navigation
- Setup and testing techniques
- Data entry & test criteria best practices
- Data management
- Report generation/expected results
- Background software routines and equations for the analysis numbers
- Laboratory activities/support

#### Audience

This course is designed for personnel who will perform and interpret control valve diagnostic testing using a QUIKLOOK 3-FS or FlowScanner 6000.

#### Prerequisites

Knowledge and experience of valves, actuators, control valve instrumentation operation and basic maintenance. Completion of 1400 or 1400V, 1700 or 1700V, and 1450 courses is recommended but not required.

### Fisher Nuclear Data Acquisition & Interpretation - Advanced – 1428 CEUs – 2.1

#### Overview

This 3 day course starts with a brief review of QUIKLOOK 3- FS or FlowScanner 6000 valve diagnostic system software. Confirms student familiarity with test setups, pressure and travel channels, and the objectives of all available test procedures. The course is based on a structured combination of lectures and hands-on labs to teach students how to identify problems in control valve assemblies. Emphasis is placed on determining and confirming overall control valve health and condition by examining each of the major components of the assembly: I/P, positioner, actuator, and valve body. Report generation and some field tips are also presented. To capitalize on learning from shared experiences, students are encouraged to bring in test data from an interesting scenario or a current problem. Those who complete this course will:

- Select the appropriate QUIKLOOK 3-FS or FlowScanner 6000 valve diagnostic system test for a given scenario.
- Understand the impact of scan rates on the appearance and interpretation of acquired data.
- Analyze valve diagnostic test data to determine overall control valve health by evaluating the condition of the various components of the assembly.
- Identify multiple anomalies in a single assembly.
- Use QUIKLOOK 3-FS of FlowScanner 6000 functions to generate reports.
- Learn how to perform a step test on a discrete valve without interrupting power to the valve.

#### Topics

- Review of various valve diagnostic tests and specific objectives of each
- Impact of test configuration errors
- Data interpretation from tests of "bugged" valve assemblies
- Multiple anomalies found in control valves
- Moving or exporting data
- Generating reports
- Interpretation of difficult to detect control valve problems

#### Audience

This course is designed for personnel who are responsible for interpreting plots and other diagnostic data that is acquired with the QUIKLOOK 3-FS or FlowScanner 6000 valve diagnostic system. This course focuses on data interpretation. Data acquisition is the primary focus in course 1427.

#### Prerequisites

A pre-test and a control valve awareness test are used to confirm applicant readiness. Course 1427 and a minimum of six months of diagnostic testing with the QUIKLOOK 3-FS or a FlowScanner 6000 valve diagnostic system.

### Fisher Control Valve & Instrument Troubleshooting – Introduction - 1450 CEUs – 2.1

#### Overview

This 3-day course uses a very hands-on approach for troubleshooting and correcting many common control valve problems. The class will be introduced to the practice of basic valve sizing and selection. Valve problems such as cavitation, flashing, and aerodynamic noise are also discussed as well as common solutions to these problems using different control valve trims and materials. Instrumentation topics are expanded from course 1400/1400V and 1700/1700V to include troubleshooting and advanced calibration for split ranging, non-compatible signals, or using additional instruments such as a volume booster and trip valves. Loop performance issues due to stick-slip, high friction, and instrument operation are discussed.

#### Topics

- Control loop basics
- Influences on loop performance
- Control valve selection and sizing
- Valve troubleshooting
- Actuator troubleshooting
- Instrument selection
- Basic instrument troubleshooting
- Severe service considerations

#### Audience

This course is for experienced valve mechanics and maintenance personnel, instrument technicians, and others who will benefit from a broadened perspective of control valve performance and effect on total loop operation.

#### Prerequisites

Completion of courses 1400 or 1400V (with 1400W) and 1700 or 1700V (with 1700W).

### Fisher Control Valve Instrument Maintenance & Calibration – 1700 CEUs – 2.1

#### Overview

This 3-day course and hands-on workshop covers the principles of operation, calibration and installation procedures for electronic and pneumatic instruments. The class will discuss maintenance procedures for Fisher sliding stem and rotary actuator assemblies. Hands on workshop exercises and lectures to discuss the operation and calibration of many Fisher instruments such as I/P transducers, pneumatic positioners, electro-pneumatic positioners, and Fisher FIELDVUE™ digital valve controllers will be covered. Students will:

- Calibrate a variety of pneumatic and electronic instruments
- Correctly perform installation procedures
- Perform basic troubleshooting of control valve instruments

#### Topics

- Actuators and bench set
- Current to pneumatic (I/P) transducers
- Instrument terminology
- Pneumatic and electro-pneumatic positioners
- Fisher FIELDVUE digital valve controller

#### Delivery Options

This training is also available as a remote virtual classroom course 1700V.

#### Audience

This course is for instrument technicians and others, responsible for pneumatic and electronic instrument calibration, installation and troubleshooting.

#### Prerequisites

Some experience in electronic and pneumatic instrument maintenance and calibration would be helpful.

### Fisher Control Valve Instrument - Maintenance & Calibration – Virtual 1700V CEUs – .8



#### Overview

This 8-hour remote virtual classroom course event consists of 4 virtual classroom parts, 2 hours for each part. It will explain the technical operation and maintenance of both sliding stem and rotary actuators. Also discussed will be the design, operation, and calibration principles for both sliding stem and rotary pneumatic positioners. Finally, the course will cover the basic operation and calibration principles for Fisher FIELDVUE digital valve controllers. Fisher documentation will be referenced and used to perform calibration procedures during live interactive sessions. Students also have the option to attend a corresponding hands-on workshop, 1700W, following the completion of the virtual classroom portion of this course.

- Identify and discuss operation principles of Fisher actuators
- Identify and discuss operation principles of Fisher pneumatic positioners
- Identify and discuss operation principles of Fisher I/P transducers
- Identify and discuss operation principles of Fisher FIELDVUE digital valve controllers

#### Topics

- Maintaining Fisher actuators
- Mounting and calibrating Fisher i2P-100
- Mounting and calibrating Fisher 3582 positioners
- Mounting and calibrating Fisher 3610J and 3610JP positioners
- Mounting and calibrating Fisher FIELDVUE digital valve controllers

#### Delivery Options

This training is also available as an Instructor Led course 1700.

#### Audience

This course offers a technical perspective for the working of Fisher positioners for control valve operation. The course is especially useful to anyone with responsibilities to repair, maintain, and calibrate valve positioners.

#### Prerequisites

Some experience with industrial control equipment including control valves and actuators would be helpful.

### Fisher Control Valve Instrument Maintenance & Calibration Assemblies - 1700W CEUs - .8

#### Overview

This 8-hour workshop is offered as an optional component following the 1700V virtual classroom event. Students will have the opportunity to perform hands-on exercises on control valve actuators and instrumentation that reinforce the maintenance topics that were discussed during the online portion of the course. The workshop is hosted in Marshalltown, IA and a workshop facilitator will be present to assist the students with any questions they may have while performing the exercises.

#### Workshops

- Fisher sliding stem actuator maintenance and repair
- Fisher 657 and 667 actuator bench set
- Fisher rotary actuator maintenance and repair
- Fisher rotary valve and actuator mounting
- Fisher I/P transducer maintenance and calibration
- Fisher 3582 positioner maintenance and calibration
- Fisher 3610J and 3610JP positioner maintenance and calibration
- Fisher FIELDVUE DVC6200 digital valve controller maintenance and calibration

#### Audience

This workshop is intended for any students that have completed the online component of the 1700V course and would like to gain some hands-on experience working with the control valve assemblies.

#### Prerequisites

Must have successfully completed the 1700V course.

### Fisher Pneumatic Pressure Controller - Maintenance & Calibration – Virtual - 1720V CEUs - .4



#### Overview

This 4-hour remote virtual classroom course event will explain the technical operation and maintenance of pneumatic pressure controllers and explain the basics of the proportional, integral, and derivative response. Maintenance of common components such as bourdon tubes and bellows elements will be discussed along with the proper procedures for calibrating various Fisher controllers.

- Fisher C1 pressure controller
- Fisher 4150/4160 pressure controller
- Fisher type 4195 pressure controller

#### Topics

- PID Actions
- Operational overview
- Zero and Span Calibration
- Changing control action
- Bourdon tube replacement C1/4150/4160
- Linkage adjustment 4195
- Flapper Leveling 4195

#### Audience

This course offers a technical perspective of the working of Fisher pneumatic pressure controllers. The course is especially useful to anyone with responsibilities to repair, maintain, calibrate, and tune pressure controllers.

#### Prerequisites

None, however some experience and familiarity to process control and general valve operation is recommended.

### Fisher Pneumatic Level Controller Maintenance & Calibration – 1730V CEUs - .4



#### Overview

This 4-hour remote virtual classroom course event will explain the technical operation and maintenance of pneumatic level controllers and transmitters. A detailed overview of displacer based level methods for applications including single fluid level, interface, and density will be covered. Basics of proportional, integral, and derivative actions are discussed as well as the proper procedures for mounting, calibrating and configuring the devices.

- Fisher 249 Displacer Sensors
- Fisher 2500 level controller
- Fisher 2502 level controller

#### Topics

- Common level measurement methods
- Displacer basics
- Torque tube construction
- Displacer mounting
- Fisher 249 displacer sensor maintenance
- Mounting and calibrating Fisher 2500
- Mounting and calibrating Fisher 2502

#### Audience

This course offers a technical perspective of Fisher pneumatic level controller and transmitter operation. The course is especially useful to anyone with responsibilities to repair, maintain, calibrate, and tune level controllers and transmitters.

#### Prerequisites

None, however some experience and familiarity to process control and general valve operation is recommended.

### Fisher FIELDVUE DLC3010 Digital Level Controller Maintenance & Calibration – 1731V CEUs - .4



#### Overview

This 4-hour remote virtual classroom course event will explain the technical operation and maintenance of FIELDVUE™ digital level controllers. An overview of displacer-based level methods for applications including single fluid level, interface, and density will be covered. The class will also discuss connecting to the device and using AMS Device Manager software or a field communicator to perform configuration and calibrations procedures

- Fisher™ 249 Displacer Sensors
- Fisher FIELDVUE DLC3010

#### Topics

- Displacer basics
- Torque tube construction
- Displacer mounting
- Fisher 249 displacer sensor maintenance
- Mounting Fisher FIELDVUE DLC3010
- Configure FIELDVUE DLC3010 using guided setup for level
- Configure the FIELDVUE DLC3010 for interface applications

#### Audience

This course offers a technical perspective of the Fisher FIELDVUE digital level controller DLC3010. The course is especially useful to anyone with responsibilities to repair, maintain, and calibrate FIELDVUE digital level controllers.

#### Prerequisites

None, however some experience and familiarity to process control and general valve operation is recommended. Completion of 1730V is strongly encouraged.

### Fisher HART based FIELDVUE Digital Valve Controllers using Emerson Field Communicators & ValveLink Mobile – Introduction - 1751 CEUs – 2.1

#### Overview

This 3-day course provides hands-on experience working with FIELDVUE™ digital valve controllers using an Emerson 475 or AMS Trex™ Communicator. The class will discuss basic operation and installation of the FIELDVUE digital valve controllers. Students will practice installing and mounting FIELDVUE digital valve controllers onto sliding stem and rotary control valve assemblies, as well as perform basic configuration and calibration of FIELDVUE Instruments. Troubleshooting the digital valve controller using ValveLink™ Mobile software will be performed and basic data interpretation will be introduced.

#### Topics

- FIELDVUE digital valve controller theory of operation
- FIELDVUE instrument installation
- Diagnostic troubleshooting and data interpretation using ValveLink Mobile with AD and PD tier devices

#### Audience

This course is for technicians, engineers and others responsible for installing, calibrating and basic troubleshooting Fisher FIELDVUE instruments using the Emerson Field Communicators with ValveLink Mobile.

#### Prerequisites

Some experience in instrument calibration and in control valve maintenance, installation, and operation would be helpful.

### Fisher HART based FIELDVUE Digital Valve Controllers using Emerson Field Communicators & ValveLink Mobile – Introduction – Virtual - 1751V CEUs – 2.1

#### Overview



This 3-day course provides hands-on experience working with FIELDVUE™ digital valve controllers using an Emerson 475 or AMS Trex™ Communicator. The class will discuss basic operation and installation of the FIELDVUE digital valve controllers. Students will practice installing and mounting FIELDVUE digital valve controllers onto sliding stem and rotary control valve assemblies, as well as perform basic configuration and calibration of FIELDVUE Instruments. Troubleshooting the digital valve controller using ValveLink™ Mobile software will be performed and basic data interpretation will be introduced.

#### Topics

- FIELDVUE digital valve controller theory of operation
- FIELDVUE instrument installation
- Diagnostic troubleshooting and data interpretation using ValveLink Mobile with AD and PD tier devices

#### Audience

This course is for technicians, engineers and others responsible for installing, calibrating and basic troubleshooting Fisher FIELDVUE instruments using the Emerson Field Communicators with ValveLink Mobile.

#### Prerequisites

Some experience in instrument calibration and in control valve maintenance, installation, and operation would be helpful.

### Fisher ValveLinkSolo Software for Configuration & Calibration of FIELDVUE Digital Valve Controllers – 1752 CEUs – 2.1

#### Overview

This 3-day course provides hands-on experience working with FIELDVUE™ digital valve controllers and ValveLink™ software. Students will be able to execute ValveLink software calibration and diagnostic routines and create an instrument database.

#### Topics

- Introduction to ValveLink Solo software
- Configuration with ValveLink software
- Calibration with ValveLink software
- ValveLink software advanced and performance Tier Diagnostics
- Troubleshooting
- Introduction to diagnostic data interpretation

#### Delivery Options

This training is also available as a remote virtual classroom course training by attending courses 1760V, 1761V, 1762V, and 1763V

#### Audience

This course is for technicians, engineers and others responsible for installation, calibration and diagnostics for FIELDVUE digital valve controllers and ValveLink software. The primary focus of this course is to provide a comprehensive experience in managing digital valve controllers using the ValveLink software.

#### Prerequisites

Some experience in instrument calibration and in control valve maintenance, installation, and operation would be helpful.

### Fisher ValveLinkSolo Software for Configuration & Calibration of FIELDVUE Digital Valve Controllers – Virtual - 1752V CEUs – 2.1



#### Overview

This 3-day course provides hands-on experience working with FIELDVUE™ digital valve controllers and ValveLink™ software. Students will be able to execute ValveLink software calibration and diagnostic routines and create an instrument database.

#### Topics

- Introduction to ValveLink Solo software
- Configuration with ValveLink software
- Calibration with ValveLink software
- ValveLink software advanced and performance Tier Diagnostics
- Troubleshooting
- Introduction to diagnostic data interpretation

#### Delivery Options

This training is also available as a remote virtual classroom course training by attending courses 1760V, 1761V, 1762V, and 1763V

#### Audience

This course is for technicians, engineers and others responsible for installation, calibration and diagnostics for FIELDVUE digital valve controllers and ValveLink software. The primary focus of this course is to provide a comprehensive experience in managing digital valve controllers using the ValveLink software.

#### Prerequisites

Some experience in instrument calibration and in control valve maintenance, installation, and operation would be helpful

### Fisher Simulated Controller Tuning – Virtual - 9006V CEUs - .8



#### Overview

This 8-hour virtual classroom course event consists of 4 parts, 2 hours for each part. Students will be introduced to the fundamentals of PID control. The control and response characteristic of each PID component will be explained and students will have the opportunity to see their effect using simulated loop software accessed through a virtual machine. Using the software, the class will also work through and discuss different strategies for tuning various process loops. These strategies include non-calculation-based methods like trial and error, as well as, calculation-based methods such as lambda tuning.

#### Topics

- Elements of PID control
- Load upsets; process noise
- Self-regulating process
- Integrating process
- Valve dead band and stick/slip
- Limit cycling
- Trial and error tuning
- Lambda tuning

#### Delivery Options

This training is also available as an Instructor Led course 9006.

#### Audience

This course is designed for those who have the job responsibility of tuning or monitoring industrial process control loops. Students will learn to tune controllers to meet the needs of each loop.

#### Prerequisites

Some basic understanding of process measurement and control is recommended.

**Fisher Diagnostic Data Interpretation using ValveLink Software for FIELDVUE -1759  
CEUs – 2.1**

**Overview**

This 3-day course uses practical exercises and discussions to teach the student to interpret and analyze diagnostic data obtained using FIELDVUE™ digital valve controllers and ValveLink software™. Students will perform diagnostic tests on a variety of valve/actuator combinations and use the data to determine bench set, dynamic error band, seat load, spring rate and other pertinent parameters. Students will also perform comparison tests on valve/actuator assemblies containing configuration or operating flaws and use the data for troubleshooting purposes.

**Topics**

- Review of ValveLink software diagnostic tests
- Data interpretation
- Troubleshooting techniques
- Comparison testing techniques
- Performance diagnostics

**Audience**

This course is for technicians, engineers and others responsible to collect and interpret valve diagnostic tests performed using ValveLink™ software.

**Prerequisites**

Students must have completed one of the following: 1751, 1752, 7036, or 1760V Series (1760V, 1761V, 1762V, 1763V).

**Fisher FIELDVUE Digital Valve Controllers – Virtual - 1760V  
CEUs - .4**



**Overview**

This 4-hour remote virtual classroom course covers the detailed operation of Fisher FIELDVUE™ digital valve controllers. Class discussions are centered on what individual components within a digital valve controller are, and how they can affect overall control valve performance. Common maintenance practices are detailed, and include proper care and handling of internal components, such as the I/P and Relay. Calibration procedures of the FIELDVUE DVC6200 digital valve controller will be conveyed using ValveLink software connected to a live device. Course focus includes:

- Identify and understand components of a digital valve controller
- Describe and demonstrate proper instrument mounting
- Connect to a live device using ValveLink Software
- Discuss and perform a guided setup routine
- Discuss and perform an auto travel calibration routine

**Topics**

- Pneumatic instrument principle overview
- Operation of a FIELDVUE digital valve controller for travel control
- Operation of a FIELDVUE digital valve controller for pressure control
- Replacing FIELDVUE digital valve controller components
- Mounting a FIELDVUE digital valve controller
- Calibrating a FIELDVUE digital valve controller

**Audience**

This course is designed for those who have the job responsibility to repair, mount, configure, and calibrate Fisher FIELDVUE digital valve controllers.

**Prerequisites**

Experience and familiarity of process control and general valve operation is recommended. Completion of course 1700 or 1700V is strongly encouraged.

**Fisher FIELDVUE Digital Valve Controller HART Communicating Tier – Virtual - 1761V  
CEUs - .4**



**Overview**

This 4-hour remote virtual classroom course event covers the detailed setup of the FIELDVUE™ digital valve controllers. The class will discuss navigating through the detailed setup menus to change device operation and configuration parameters, as well as set alerts and alarms and correctly complete the device specification sheet. Students will have access to a live FIELDVUE DVC6200 using ValveLink™ software. In conjunction with HC tiering capabilities, a basic understanding of functions and troubleshooting within ValveLink software is discussed at length. Course focus includes:

- Detailed Setup - basic page group
- Detailed Setup - alert page group
- Detailed Setup - specification sheet
- Status Monitor
- Stroke Valve Test

**Topics**

- Saving device configuration as found
- Viewing device datasets
- Comparing current datasets to historical datasets
- Restoring historical datasets
- Using status monitor
- Interpreting data from status monitor
- Performing a stroke valve test

**Audience**

This course is designed for those who have the job responsibility to perform detailed configurations and basic diagnostic troubleshooting of FIELDVUE digital valve controllers with HC tier.

**Prerequisites**

Successful completion of 1760V is required.



**Fisher FIELDVUE Digital Valve Controller Advanced Diagnostics Tier – Virtual - 1762V CEUs - .4**



**Overview**

This 4-hour remote virtual classroom course event introduces data collection methods for offline diagnostic testing and troubleshooting of the FIELDVUE™ digital valve controllers with Advanced Diagnostic (AD) Tier. Students will have access to a live FIELDVUE DVC6200 using ValveLink™ software and will discuss the proper setup and execution of diagnostic functionality within the AD tier. Dynamic scan and step response tests will be conducted, and the class will interpret analyzed data and review the details of diagnostic graphs for each. Areas of focus for AD diagnostic functionality include:

- Step Response Test - stroking speed
- Step Response Test - 9 -point step test
- Step Response Test - performance test
- Step Response Test – 3-point ramp
- Step Response Test - supply pressure
- Step Response Test - drive signal
- Valve Signature - graph and analyzed data
- Dynamic Error Band
- Drive Signal

**Topics**

- Verifying specification sheet information
- Viewing/initializing AD related diagnostic information
- Identifying common features of diagnostic graphs
- Interpreting AD tier diagnostics

**Audience**

This course is designed for those with job responsibilities to configure and perform diagnostic tests as well as interpret diagnostic data of the FIELDVUE digital valve controller with AD tiering.

**Prerequisites**

Successful completion of 1760V and 1761V is required.

**Fisher FIELDVUE Digital Valve Controller Performance Diagnostics Tier – 1763V CEUs - .4**



**Overview**

This 4-hour remote virtual classroom course event introduces data collection methods for online diagnostic testing and troubleshooting of the FIELDVUE™ digital valve controllers with Performance Diagnostic (PD) Tier. Students will have access to a live FIELDVUE DVC6200 device using ValveLink software and will discuss the proper setup and execution of diagnostic functionality within the PD tier. Permanent tiering step-up options are discussed, including the free one-time step up to PD tier, as well as specific procedures to follow when changing a digital valve controller's diagnostic tier. Diagnostic functions of interest include:

- PD One Button
- Profiles
- Triggered Profiles
- Friction
- Friction Trends

**Topics**

- Verifying specification sheet information
- Running a PD One Button Test
- Viewing/analyzing PD related diagnostic information
- Configuring scheduler to run diagnostics
- Configuring/Activating trending and network alert scan functions
- Understanding digital valve controller diagnostic tiering levels

**Audience**

This course is designed for those with job responsibilities to perform and interpret online diagnostic tests associated with the FIELDVUE digital valve controller with PD tiering.

**Prerequisites**

Successful completion of 1760V, 1761V, and 1762V is required.

**Fisher FOUNDATION fieldbus FIELDVUE Digital Valve Controller – 7036 CEUs – 2.1**

**Overview**

This 3-day course reviews the role and function of control valve positioners followed by a series of hands-on exercises to disassemble, inspect, assemble, install, and commission a FOUNDATION™ fieldbus FIELDVUE™ digital valve controller. During commissioning, students will learn the basics of the FOUNDATION fieldbus protocol, the role of function blocks, addressing, modes and status. Students will configure, calibrate, and commission devices using Emerson Communicator and ValveLink™ Solo software. Hands-on exercises also teach students how to perform detailed setup routines and how to run and collect data for various ValveLink software diagnostics.

**Topics**

- Positioner Basics
- FOUNDATION fieldbus overview
- FIELDVUE digital valve controller installation and mounting
- Modes and status
- Configuration and calibration with the 475 or AMS Trex™ Communicator and ValveLink Mobile
- ValveLink software guided Setup /Detailed Setup
- Tuning
- Tag management
- Pressure control
- ValveLink software diagnostics
- FIELDVUE instrument troubleshooting

**Audience**

This course teaches technicians and engineers the basics of FOUNDATION fieldbus digital valve controller installation, configuration, calibration, and troubleshooting.

**Prerequisites**

Some experience in instrument calibration and in control valve maintenance, installation, and operation would be helpful.

### Fisher Valve Standards Overview - e0010 CEUs – 0.1



#### Overview

This course introduces standards organizations such as ANSI, ASME, IEC and others that are commonly recognized in process control applications. The course will provide an overview of many common standards and identifying marks, as well as, review how these standards are applied to both the design and manufacturing of valves used for isolation and flow control.

#### Objectives

- Describe the purpose of standards
- Identify design/manufacturing fundamental standards
- Identify design/manufacturing fundamental standards

### Fisher Pressure Standards Overview - e0011 CEUs – 0.1



#### Overview

This course introduces pressure classifications as specified by ASME standard B16.34, specifically as it applies to valve selection and maintenance for process control applications. The course discusses design considerations that influence pressure ratings during engineering and selection, specifically related to process temperatures, pressures, and materials used for the construction of the valve body and bonnet components. This course will also cover hydrostatic testing to verify the integrity of pressure retaining components and ensure they meet industry standards. Hydrostatic testing types, basic test procedure, and compliance markings on the valves are all covered. Finally, this course will also discuss the impact of pressure class ratings on maintenance of control valve assemblies such setting the appropriate torque for valve packing.

#### Objectives

- Describe the purpose of the pressure class
- Recall pressure class fundamentals
- Identify pressure class ratings
- Identify pressure class torque practices
- Identify valve selection process steps

### Fisher Leakage Standards Overview - e0012 CEUs – 0.1



#### Overview

This course introduces shutoff/leakage class standards such as ANSI FCI 70-2 and API 598 for isolation and flow control valves used in process applications. The course will describe shutoff/leakage considerations and differences for both flow control valves and isolation valves, as well as, testing for shutoff/leakage as defined by the standards and specifications used by Fisher Controls during manufacture of valve assemblies.

#### Objectives

- Describe the purpose of leakage class
- Identify leakage class fundamentals
- Identify leakage classes
- Describe leakage class testing procedures
- Identify leakage class tables



**AutoStat for AMS Machinery Manager  
Virtual Classroom – 2070CV  
CEUs - 1.4**



**Overview**

AutoStat is included in the standard curriculum of the 4-day Advanced AMS Machinery Manager course (course # 2070). This 2-day session only covers AutoStat in the AMS Machinery Manager software.

Alarms are an important part of any analysis program. Properly setting alarms allows the user to quickly identify an abnormal machine condition and reduces time spent analyzing machines that are running in acceptable or “normal” condition.

AMS Machinery Manager provides the user the ability to create up to 12 parameter bands with alarms in addition to the Overall value. Calculating ideal alarm values for these parameters can be very complicated. **AutoStat** uses statistical analysis to provide limit values for the individual parameter bands by analyzing the data associated with similar pieces of equipment.

This 2-day session is designed for students have a basic understanding of AMS Machinery Manager and will guide these users through the process of using AutoStat for the generation of both Analysis Parameter sets and Statistical narrowband Envelope generation.

**Topics**

- Creating Analysis Groups
- Modifying Parameter Band Alarms
- Creating New Alarm Limits
- Parameter band Alarms versus Narrow Band Alarms
- Creating Statistical Envelopes

**Machinery Health Plantweb Optics -  
Introduction – 2040  
CEUs – 1.4**

**Overview**

This 2-day course is designed for new users of the Plantweb Optics software and is based on the current software release. Students will learn how to navigate through the software, manage the database and add locations using the Plantweb Optics Asset Explorer utility. Students will bind physical locations to logical locations.

Students will also learn how to navigate the Plantweb Optics Asset Viewer utility used on PC/ laptop and mobile device applications to receive real-time information about equipment that is relevant to their job

**Topics**

- Basic Navigation
- Database Building using the Asset Explorer utility
- Asset Viewer utility and subscriptions
- Historian
- Dashboard
- User Manager (Setting users/Permissions/Tokens for the App)
- Asset Viewer utility Mobile App
- Asset Source Interface (ASIs)

**Prerequisites**

Computer experience with the Windows operating system and some vibration analysis experience are recommended.

**Machinery Health Plantweb Optics -  
Introduction – Virtual - 2040V  
CEUs – 1.4**



**Overview**

This 2-day course is designed for new users of the Plantweb Optics software and is based on the current software release. Students will learn how to navigate through the software, manage the database and add locations using the Plantweb Optics Asset Explorer utility. Students will bind physical locations to logical locations.

Students will also learn how to navigate the Plantweb Optics Asset Viewer utility used on PC/ laptop and mobile device applications to receive real-time information about equipment that is relevant to their job

**Topics**

- Basic Navigation
- Database Building using the Asset Explorer utility
- Asset Viewer utility and subscriptions
- Historian
- Dashboard
- User Manager (Setting users/Permissions/Tokens for the App)
- Asset Viewer utility Mobile App
- Asset Source Interface (ASIs)

**Prerequisites**

Computer experience with the Windows operating system and some vibration analysis experience are recommended.

### Machinery Health Plantweb Optics Deployment – 2041 CEU – 0.8

#### Overview

This course goes through the specific tasks necessary to properly deploy Plantweb Optics. It is part of a deployment certification path for Plantweb Optics

#### Topics

- Pre-trip readiness elements
- WebEx kickoff
- SQL database setup
- Network architectures
- Cyber deployment declarations
- Data source readiness
- Functional Design Specification document used as the checklist for site visit readiness.
- Detailed deployment task
- All checklists Installing the software and basic training
- Network and cyber security essentials are covered during the architecture discussions.

#### Prerequisites

None

### AMS Machine Works – 2042 CEU – 1.4

#### Overview

This 2-day course is designed for users of AMS Machine Works and is based on the current software release. Students will learn how to navigate through the software and manage the database by adding devices from the network configuring those devices for data collection and data storage. Students will also be instructed on how to map the collected data to measurement point locations by machine for detailed data analysis which includes alarms and the calculation of fault frequencies. Collected data will be analyzed using the AMS Machine Works Vibration Analyzer and problem reports will be documented using Machine Journal.

Devices discussed include the AMS 9420, AMS 6500 ATG and the AMS Wireless Vibration Monitor.

Topics covered include:

- Basic Navigation
- Database Building using the Asset Explorer utility
- Machine Journal
- User Manager
- Dashboard
- Mobile App

**Prerequisites:** Computer experience with the Windows operating system and some vibration analysis experience are recommended.

### AMS Machine Works – Virtual – 2042V CEU – 1.4



#### Overview

This 2-day course is designed for users of AMS Machine Works and is based on the current software release. Students will learn how to navigate through the software, manage the database and add locations using the Plantweb Optics Asset Explorer utility. The AMS 9420 and AMS 6500 ATG are used to show the user how to connect vibration measurement points for data collection. Collected data will be analyzed using AMS Machine Works Vibration Analyzer. Students will also learn how to use mobile device applications to receive real-time information about equipment that is relevant to their job.

#### Topics

- Basic Navigation
- Database Building using the Asset Explorer utility
- Machine Journal
- Dashboard
- Mobile App

#### Prerequisites

Computer experience with the Windows operating system and some vibration analysis experience are recommended.

### Machinery Health - Customizing Analysis Parameter Sets – 2004 CEUs – 2.1

and

#### Overview

This 3-day workshop is the fifth in our series of AMS Machinery Manager courses. This course will instruct users on how to enhance an existing database by calculating and implementing improved Analysis Parameter (AP) sets. Students will learn how to identify when an AP set needs to be adjusted and how to make the adjustments effectively. Applications will include Vibration Analysis tab, Database Setup and Database Utility.

#### Topics

- AP Set Review
- AP Set Characteristics
- AP Set Creation
- Reasons for Reviewing and Adjusting AP Sets
- PeakVue

#### Prerequisites

Introduction to AMS Machinery Manager (course #2068), Intermediate AMS Machinery Manager (course #2074), Intermediate Vibration (course #2032) or two years' vibration analysis experience are strongly recommended.

#### Audience

AMS Machinery Manager Software users.

### Machinery Health Analytics KNet – Introduction – 2920V CEUs – 1.4



#### Overview

This 1.5 - 2 day course (3 sessions of 4 hours) uses lectures and hands-on workshops to provide an in-depth overview of KNet and the configuration of pre-engineered templates.

The students will:

- Understand KNet architecture
- Get familiar with KNet development environment
- Understand the connectivity options
- Discover existing pre-engineered Emerson Templates
- Understand step-by-step configuration of a template
- Manipulate tools to configure templates
- Learn how to deploy a template project
- Understand the license model & quote tool
- Get an overview about the data driven approach

#### Topics

- KNet Installation
- Architecture
- KNet Online Overview
- KNet License
- Connectivity
- KNet Core Modules
- KNet Development Environment
- KNet Modules
- Templates
- Emerson Templates
- License Model
- Quote Tool
- Data Driven Overview

#### Audience

This course is for operations, engineers, and managers responsible for configuring pre-engineered analytics templates using KNet.

**Prerequisites:** None

### Machinery Health AMS 9420 Wireless Vibration Transmitter for Machinery Manager - 2025 CEUs - 1.4

#### Overview

This 2-day course is intended for technicians, engineers and other plant personnel who need to know to setup, maintain, troubleshoot, and view data from the AMS 9420 Wireless Vibration Transmitter in conjunction with the AMS Machinery Manager Software. The course uses lecture and labs to maximize the hands-on experience for the students.

#### Topics

- Overview of AMS 9420 hardware components
- Overview of the 1420 Wireless Gateway
- Vibration basics and terminology relating to AMS 9420
- Import data into AMS Machinery Manager
- View data using AMS Machinery Manager
- Troubleshooting and maintenance

#### Audience

This course is intended for technicians, engineers and other plant personnel who need to know how to setup, maintain, troubleshoot, and view data from the AMS 9420 Wireless Vibration Transmitter

#### Prerequisites

Course 2375 (Wireless Self Organizing Network) and some experience in Networks and Host integration would be helpful.

### Machinery Health Vibration Analysis Module for AMS Machinery Manager, Blended Learning - 2008B CEUs - 1.4

#### Overview

The purpose of this blended learning workshop is to provide the vibration analyst with an interactive learning environment that enhances their understanding of the features of the Vibration Analysis program using Emerson's AMS Machinery Manager Software. This workshop was designed as a self-paced blended learning training experience. The student will be provided with a workbook, access to a Virtual Training Computer and an eLearning module.

The workbook contains eleven topical exercises for use with the Vibration Analysis tab in AMS Machinery Manager software. The student will also be given a link to a Virtual Training Computer to complete the exercises using AMS Machinery Manager software. If there are questions on how to complete steps in the exercise, an eLearning module will provide assistance to the student.

If questions cannot be answered with the assistance of the eLearning module, students will also be able to email questions to an instructor at [mhm.training@emerson.com](mailto:mhm.training@emerson.com). Instructors will respond to students as quickly as possible.

#### Objectives

Provide the student with self-paced exercises to advance his/her knowledge and proficiency with the use of AMS Machinery Manager Vibration Analysis tools.

#### Prerequisite

Some knowledge of AMS Machinery Manager software and basic vibration analysis is recommended.

### Machinery Health Analyzer CSI 2130 – Introduction - e2130 CEUs - 0.6



#### Overview

Emerson's Machinery Health™ training now includes Fundamentals of the 2130 eLearning course, designed to provide you with the tools you need to perform data collection using the CSI 2130 Machinery Health Analyzer. This course provides guided demonstrations through the processes of installing necessary drivers, uploading updated firmware, and loading updated or newly-purchased programs necessary for data collection. Learn how to load a pre-defined route into the CSI 2130, gather general data as well as specialized data, and then interface the data back with a computer for further diagnostic analysis.

#### Topics

- Analyzer-Computer Communication
- Predefined Route Data Collection
- Off-Route Data Collection and Setup
- Monitor Mode Measurements
- Peak and Phase Measurements



### Machinery Health AMS 2140 – Introduction - 2076

#### CEUs - 1.4

##### Overview

This 2-day hands-on course focuses on the basic operation of the AMS 2140 Machinery Health™ Analyzer. Students collect data on lab machines. Note: You may take with Fundamentals of Vibration as a 4-day course.

##### Topics

- Analyzer/Computer Communication
- Predefined Route Data Collection
- Job Data Collection and Setup
- Manual Mode Measurements
- Introduction to AMS 2140 Analysis Expert Functions

##### Audience

This course is designed for personnel with little or no experience with Emerson analyzers, but who are experienced in the field of vibration data collection and analysis.

##### Prerequisites

Understanding of vibration analysis. Familiar with basic vibration collection principles.

### Machinery Health AMS 2140 – Introduction – Virtual - 2076V

#### CEUs - 1.4



##### Overview

This 2-day hands-on course focuses on the basic operation of the AMS 2140 Machinery Health™ Analyzer. Students collect data on lab machines. Note: You may take with Fundamentals of Vibration as a 4-day course.

##### Topics

- Analyzer/Computer Communication
- Predefined Route Data Collection
- Job Data Collection and Setup
- Manual Mode Measurements
- Introduction to AMS 2140 Analysis Expert Functions

##### Audience

This course is designed for personnel with little or no experience with Emerson analyzers, but who are experienced in the field of vibration data collection and analysis.

##### Prerequisites

Understanding of vibration analysis. Familiar with basic vibration collection principles.

### Machinery Health AMS 2140 – Advanced - 2094

#### CEUs - 2.1

##### Overview

This 3-day course is intended for personnel with single-channel vibration analysis experience and little or no multi-channel experience. This class covers advanced signal processing using Emerson's patented PEAKVUE™ technology for slow-speed analysis, coherence and cross-channel phase, operating deflection shapes (ODS), modal analysis, and other advanced techniques.

##### Topics

- PEAKVUE™
- Resonance Detection
- Dual Channel Data Collection
- Fundamentals of Cross-Channel Data Collection
- Introduction to Coherence and Cross-Channel Phase
- Orbit Data Collection
- Introduction to Operating Deflection Shape (ODS) Testing Methods
- Introduction to Modal Analysis Testing Methods
- Advanced Two-Channel DLP
- Zoom Analysis, Cascade, and Overall
- Transient Time Waveform Capture and Analysis
- AMS 2140 Analysis Experts Functions

##### Audience

This course is intended for personnel with single-channel vibration analysis experience and little or no multi-channel experience.

##### Prerequisites

Single channel vibration analysis experience is required.

### Machinery Health AMS 2140 – Advanced – Virtual – 2094V

#### CEUs - 2.1



##### Overview

This 3-day course is intended for personnel with single-channel vibration analysis experience and little or no multi-channel experience. This class covers advanced signal processing using Emerson's patented PEAKVUE™ technology for slow-speed analysis, coherence and cross-channel phase, operating deflection shapes (ODS), modal analysis, and other advanced techniques.

##### Topics

- PEAKVUE™
- Resonance Detection
- Dual Channel Data Collection
- Fundamentals of Cross-Channel Data Collection
- Introduction to Coherence and Cross-Channel Phase
- Orbit Data Collection
- Introduction to Operating Deflection Shape (ODS) Testing Methods

### 2094V – Continued...

- Introduction to Modal Analysis Testing Methods
- Advanced Two-Channel DLP
- Zoom Analysis, Cascade, and Overall
- Transient Time Waveform Capture and Analysis
- AMS 2140 Analysis Experts Functions

### Machinery Health™ - Vibration – Introduction - 2069

#### CEUs - 1.4

##### Overview

The 2-day class prepares participants for the Basic Vibration Analysis Course. Students learn about causes of vibration and methods of measurement. Although the training course does not provide instruction on Emerson's technologies, the class will use them to demonstrate vibration principles.

##### Topics

- Introduction to Vibration Components of a Predictive Maintenance Program
- Basic Fault Identification
- Vibratory Fault Characteristics and Patterns
- Information to Help Jump Start a Vibration Program

##### Audience

This vibration training course is for those with no prior experience in vibration analysis.

### Machinery Health Vibration – Introduction - e2069

#### CEUs - 0.2



##### Overview

The course introduces the technology of vibration analysis by explaining what vibration analysis is and how it plays a critical role in any predictive maintenance program. Students are led through a self-paced discussion on how vibration analysis works with many examples of the types of faults that can be detected. Students will also gain an understanding of where and how vibration is measured with an emphasis on good data collection techniques. Students will learn important terminology that will be critical to their success as they progress to the next level of training in vibration analysis; Emerson's Basic Vibration Analysis course.

##### Topics

- Chapter 1: Fundamentals of Vibration
- Chapter 2: How is Vibration Measured?
- Chapter 3: Understanding the Vibration Signal
- Chapter 4: Vibration Units
- Chapter 5: Analysis Parameters
- Chapter 6: Data Analysis: Where to begin?

##### Audience

This e-course provides instruction to individuals with no prior experience in vibration analysis.

### Machinery Health Vibration & AMS 2140 - Introduction – 2014 CEUs – 2.8

#### Overview

This 4-day course is for those with no prior experience in vibration analysis. Students learn about causes of vibration and methods of measurement. The AMS 2140 analyzer portion of the course focuses on the basic operation of the AMS 2140 Machinery Health Analyzer. Students collect data on lab machines.

#### Topics

- Introduction to Vibration
- Components of a Predictive Maintenance Program
- Basic Fault Identification
- Vibratory Fault Characteristics and Patterns
- Information to Help Jump Start a Vibration Program.
- Analyzer/computer communication
- Predefined route data collection
- Job data collection and setup
- Manual mode measurements
- Introduction to AMS 2140 Analysis Expert Functions

#### Prerequisites

None

### Machinery Health Vibration & AMS 2140 - Introduction – 2014 CEUs – 2.8



#### Overview

This 4-day course is for those with no prior experience in vibration analysis. Students learn about causes of vibration and methods of measurement. The AMS 2140 analyzer portion of the course focuses on the basic operation of the AMS 2140 Machinery Health Analyzer. Students collect data on lab machines.

#### Topics

- Introduction to Vibration
- Components of a Predictive Maintenance Program
- Basic Fault Identification
- Vibratory Fault Characteristics and Patterns
- Information to Help Jump Start a Vibration Program.
- Analyzer/computer communication
- Predefined route data collection
- Job data collection and setup
- Manual mode measurements
- Introduction to AMS 2140 Analysis Expert Functions

#### Prerequisites

None

### Machinery Health Balancing Theory & Application for AMS 2140 - 2016 CEUs - 2.8

#### Overview

This 4-day class (2 days on Balancing Theory and 2 days on Balancing Applications with AMS 2140) teaches how to perform single- and dual-plane balancing using both graphical and analyzer-based balancing methods. The class uses the AMS 2140 Machinery Health™ Analyzer on lab machinery.

#### Topics

- Imbalance identification
- Use of vectors
- Calculating influence coefficients
- Use of the auxiliary analyzer balance functions
- Use of UltraMgr module
- Calculating a system lag
- Estimate trial weights
- Balancing flexible rotor systems
- Balancing overhung rotors
- Applying balancing techniques in an industrial setting

#### Prerequisites

Understanding of vibration analysis is recommended.

### Machinery Health AMS 2140 – Introduction - e2140 CEUs - 0.6



#### Overview

Emerson's Machinery Health™ training now includes the Fundamentals of the AMS 2140 eLearning course, designed to provide you with the tools you need to perform data collection using the AMS 2140 Machinery Health Analyzer. The course leads you through a basic introduction of the analyzer including panel descriptions and reviews of the purpose and function of all connectors, ports, slots, keys, indicators and buttons. The user learns how to load a pre-defined route into the analyzer, take general data as well as specialized data, and then dump that data back into the computer for further diagnostic analysis.

#### Topics

- Analyzer/Computer Communication
- Predefined Route Data Collection
- Job Data Collection and Setup
- Manual Mode Measurements
- Introduction to AMS 2140 Analysis Expert Functions

### Machinery Health Vibration Analysis Category I - 2031 CEUs – 3.0

#### Overview

This 4-day course complies with Category I Vibration Analyst per ISO standard 18436-2: Vibration condition monitoring and diagnostics. Although this training course is not product specific, students will use Emerson's AMS technologies for demonstration purposes. The class shows the student how to use the vibration analyzer in conjunction with Emerson AMS Machinery Manager software to analyze basic vibration defects. Participants will receive a complimentary copy of the Pocket Vibration Analysis Trouble-Shooter Guide.

#### Topics

- Introduction to Vibration
- Measurement Setup
- Data collection and analysis
- Basic analyzer functions
- The class shows the students how to recognize machine defects such as:
  - Imbalance
  - Shaft misalignment
  - Looseness
  - Rolling element bearing defects
  - Gear problems
  - Resonance
  - Belt Defects
  - AC Induction Motors
  - Journal Bearings
  - Rotating Equipment

#### Audience

This course is intended to enable students to operate single channel machinery analyzers, dump and load routes, recognize the difference between good and bad data, and compare vibration measurements against pre-established alert settings.

#### Prerequisites

Fundamentals of vibration or up to six months of vibration experience is recommended.

### Machinery Health Vibration Analyst Exam Category I - 2021EX

#### Overview

Format: Written exam  
Duration: 2 hours  
Passing Grade: 70%

#### Eligibility for Examination

- Minimum Duration of Training (hours): 30
- Minimum Duration of Cumulated Experience (months): 6

### Machinery Health Vibration Analysis Category II - 2032

CEUs - 2.8

#### Overview

This 4-day course complies with Category II Vibration Analyst per ISO standard 18436-2: Vibration condition monitoring and diagnostics. Category II vibration analysts are expected to be able to select appropriate vibration measurement techniques, set up instruments for basic resolution of amplitude, frequency, and time, perform basic spectrum analysis, maintain a database of results and trends, perform single-channel impact tests, classify, interpret, and evaluate test results in accordance with applicable specifications and standards, recommend minor corrective actions, and understand basic single plane field balancing concepts.

This course also features the use of the Emerson Machinery Analyzer in conjunction with advanced machinery analysis techniques. Discussions of case histories on machinery faults are one of the focal points of this course. Students will receive a complimentary copy of the Simplified Handbook of Vibration Analysis, Volume I, by Art Crawford.

#### Topics

Recognition of Machine Defects including:

- Reference Standards
- Imbalance
- Misalignment
- Bent Shaft
- Soft Foot
- Antifriction and Journal Bearings
- Looseness
- Resonance
- Electrical Defects
- Gearboxes
- Belts

#### Prerequisites

Basic Vibration Analysis course and a cumulative 18 months of field experience are recommended.

### Machinery Health Vibration Analysis Category II – Virtual - 2032V

CEUs - 2.8



#### Overview

This 4-day course complies with Category II Vibration Analyst per ISO standard 18436-2: Vibration condition monitoring and diagnostics. Category II vibration analysts are expected to be able to select appropriate vibration measurement techniques, set up instruments for basic resolution of amplitude, frequency, and time, perform basic spectrum analysis, maintain a database of results and trends, perform single-channel impact tests, classify, interpret, and evaluate test results in accordance with applicable specifications and standards, recommend minor corrective actions, and understand basic single plane field balancing concepts.

### 2032V – Continued...

This course also features the use of the Emerson Machinery Analyzer in conjunction with advanced machinery analysis techniques. Discussions of case histories on machinery faults are one of the focal points of this course. Students will receive a complimentary copy of the Simplified Handbook of Vibration Analysis, Volume I, by Art Crawford.

#### Topics

Recognition of Machine Defects including:

- Reference Standards
- Imbalance
- Misalignment
- Bent Shaft
- Soft Foot
- Antifriction and Journal Bearings
- Looseness
- Resonance
- Electrical Defects
- Gearboxes
- Belts

### Machinery Health Vibration Analyst Exam Category II - 2022EX

#### Overview

Test Format: Written exam

Duration: 3 hours

Passing Grade: 70%

#### Eligibility for Examination

- Minimum Duration of Training (hours): 70
- Minimum Duration of Cumulated Experience (months): 18
- Passing Category I exam is NOT a prerequisite for taking Category II exam.

### Machinery Health Vibration Analysis Category III – 2033

CEUs - 2.8

#### Overview

This 4-day course complies with Category III Vibration Analyst per ISO standard 18436-2: Vibration condition monitoring and diagnostics. This course expands on the subjects covered in the Intermediate Vibration course (Category II), especially in the areas of fault analysis and corrective actions. The class details advanced analysis techniques. The dual channel Machinery Health™ analyzer features are introduced including the use of AMS Machinery Manager Software to set up the advanced analyzer features and the powerful download-able programs for data collection. The transient Machinery Health analyzer capabilities are covered such as long-term time waveform. The class covers advanced resonance detection using a variety of testing methods, including triggered data collection.

Students will receive a complimentary copy of the Simplified Handbook of Vibration Analysis, Volume I, by Art Crawford.

### 2033 – Continued...

#### Topics

- Specify Appropriate Vibration Instrumentation Hardware and Software for both Portable and Permanently Installed Systems
- Perform Spectrum and Time Waveform Analysis Under both Steady-State and Unsteady Operating Conditions
- Measure and Analyze Basic Operational Deflection Shapes (ODS)
- Slow Speed Technology (SST®)
- Zoom Analysis
- Transient Techniques
- Digital Signal Processing
- Demodulation
- Resonance Detection

#### Prerequisites

Intermediate Vibration Analysis course and a cumulative three years of field experience are recommended.

### Machinery Health Vibration Analyst Exam Category III - 2023EX

#### Overview

Category III exam, available at the end of course# 2033

Test Format: Written exam

Duration: 4 hours

Passing Grade: 70%

#### Eligibility for Examination

- Minimum Duration of Training (hours): Category II + 38
- Minimum Duration of Cumulated Experience (months): 36
- Has taken and passed the Category II exam.

### Machinery Health Windows- Based Operating Deflection Shape & Modal for AMS 2140 - Introduction - 2039

CEUs - 2.8

#### Overview

This 4-day course is designed to teach Operating Deflection Shape (ODS) and Modal Analysis software. This course uses the CSI 2130 or AMS 2140 single- and dual-channel Machinery Health™ Analyzers to teach the practical concepts of ODS/modal measurement techniques and display options. The modal course is introductory and will not cover theory or mathematical background.

#### Topics

- Building of the Wireframe Model
- Measurement Considerations
- Collecting ODS Data With and Without a Tachometer Reference
- Utilizing an Impact Hammer with the CSI 2130 or AMS 2140 Advanced Dual-Channel DLP
- Interpretation of Results

#### Prerequisites

Knowledge of dual-channel analyzers and at least one year of full-time vibration analysis experience is recommended.

### Machinery Health Vibration Analysis Category IV – Introduction – 2034 CEUs – 3.5

#### Overview

This course is part one of the two courses required for the Category IV examination.

This 5-day class is designed to allow the students to better understand rotor dynamics and their options when facing a problem piece of equipment that is running at or close to its critical speeds. This course will provide vibration analysts a road map to develop a plan to perform basic calculations to estimate the critical speeds of different types of machinery. Lab calculations will be performed by the students throughout the course to reinforce topics learned in the class. These techniques can be applied to all types of rotating machinery using either journal bearings or rolling element bearings.

#### Topics

- Introduction to Basic Rotor Dynamics
- Natural Frequencies
- Free versus Forced Vibrations
- Stiffness
- Damping
- Natural Frequency Equations
- Forced Vibrations
- Amplification (Q) Factor calculation Methods
- Types of Journal Bearings
- Center Hung Rotors versus Overhung Rotors
- Rigid Rotors versus Flexible Rotors
- Subharmonic Resonance
- Shaft Instabilities
- Cracked Shafts
- Required Information for Critical Speed Analysis
- Field Testing for Modeling Requirements
- Rotor Modeling
- Shaft Hand Calculations
- Computer Modeling

#### Audience

Vibration analysts, reliability engineers  
Prerequisites

Pass Category III exam

### Machinery Health PeakVue Analysis & Autocorrelation – 2035 CEUs - 2.1

#### Overview

This 3-day course provides insight into advanced functionality of Emerson's unique PeakVue and PeakVue Plus technology and Autocorrelation. Machine vibrations generate both macro and microscopic vibrations, and microscopic vibrations generate stress waves that have frequency ranges determined by the mass of the impacting object. The properties of these stress waves will be explained.

Autocorrelation will teach the power of correlated waveform analysis. The same time waveform used for autocorrelation is used by the FFT to generate the spectrum. The strengths of the autocorrelation data are complimentary to the strengths of the spectral data.

This course makes use of case studies from real-life examples of common faults and live demonstrations illustrating specific mounting procedures to reliably detect certain faults. Comparisons between PeakVue technology techniques and demodulation will also be demonstrated.

#### Topics

- Proper PeakVue technology set-ups for all speeds (as low as 1 rpm)
- Sensor selection and sensor mounting
- Setting alarm levels
- Choosing trend parameters
- Analyzing PeakVue technology spectra and waveforms
- Uses of the circular waveform plot
- Introduce the autocorrelation coefficient
- Highlight the strengths of the autocorrelation coefficient function data relative to spectra data
- Demonstrate the use of the autocorrelation coefficient data as a diagnostic tool to support the spectra data for vibration analysis through several case studies.
- Identify unique patterns of the autocorrelation function data for certain classes of bearing faults, gearing faults, etc.

#### Prerequisites

Students should be familiar with AMS Machinery Manager software, fundamentals of the AMS 2140 and conventional vibration data collection and analysis techniques.

### Machinery Health PeakVue Analysis & Autocorrelation – 2035V – Virtual CEUs - 2.1



#### Overview

This 3-day course provides insight into advanced functionality of Emerson's unique PeakVue and PeakVue Plus technology and Autocorrelation. Machine vibrations generate both macro and microscopic vibrations, and microscopic vibrations generate stress waves that have frequency ranges determined by the mass of the impacting object. The properties of these stress waves will be explained.

Autocorrelation will teach the power of correlated waveform analysis. The same time waveform used for autocorrelation is used by the FFT to generate the spectrum. The strengths of the autocorrelation data are complimentary to the strengths of the spectral data.

This course makes use of case studies from real-life examples of common faults and live demonstrations illustrating specific mounting procedures to reliably detect certain faults. Comparisons between PeakVue technology techniques and demodulation will also be demonstrated.

#### Topics

- Proper PeakVue technology set-ups for all speeds (as low as 1 rpm)
- Sensor selection and sensor mounting
- Setting alarm levels
- Choosing trend parameters
- Analyzing PeakVue technology spectra and waveforms
- Uses of the circular waveform plot
- Introduce the autocorrelation coefficient
- Highlight the strengths of the autocorrelation coefficient function data relative to spectra data
- Demonstrate the use of the autocorrelation coefficient data as a diagnostic tool to support the spectra data for vibration analysis through several case studies.
- Identify unique patterns of the autocorrelation function data for certain classes of bearing faults, gearing faults, etc.

#### Prerequisites

Students should be familiar with AMS Machinery Manager software, fundamentals of the AMS 2140 and conventional vibration data collection and analysis techniques.



### Machinery Health Reciprocating Equipment Analysis – 2050 CEUs – 2.1

#### Overview

This 3-day course will familiarize students with the advantages of condition monitoring of reciprocating equipment using Emerson's AMS 2140 analyzer and AMS 6500. This course will also demonstrate how to correctly setup databases to accurately diagnose equipment faults and possible deficiencies.

#### Topics

Key learning topics will include database setup, transducer selection and mounting (best practices), and accurate deficiency identification of reciprocating engine and compressor faults as related to crankshaft angle.

- Overview of reciprocating equipment in various industries
- Operation
- Component familiarization
- Database setup
- Proper transducer selection
- Best practices for data collection
- Data analysis
- Case studies/examples

#### Audience

Anybody who wishes to monitor reciprocating equipment using Emerson's AMS 2140 and AMS Machinery Manager Software

#### Prerequisites

Familiarity with the AMS 2140, AMS 6500 and AMS Machinery Manager software are highly recommended.

### Machinery Health Time Waveform Analysis – 2051 CEUs – 2.1

#### Overview

This 3-day course is designed to upgrade and enhance waveform analysis skills for vibration technician and reliability engineers. There are several reasons that vibration analysts want to understand and use waveform analysis, since some significant defects are better analyzed in the time domain. The time domain provides visual confirmation of amplitude enhancement and reduction. Time waveform analysis can present, in a static picture, amplitude variations and changes in frequencies that the FFT cannot display without using multiple (dynamic) graphics. Further, a waveform graphically presents accurate peak vibration amplitudes representing defect severity.

#### Topics

- **Waveform Data Acquisition:** Analog to Digital Conversion (A/D)
- **Waveform Parameters for Trending:** Peak to Peak, Crest Factor, and Analog Overall
- **Waveform Tools:** Revolution Markers, Difference Frequency markers, Phase, Peak, RMS, Crest Factor

### 2051 – Continued...

- **Waveform Patterns:** Sinusoidal, Impacting, Truncated, Asymmetric, Transient/Random, Modulated and Discontinuity or Bad/Compromised Data.
- **FFT vs. Waveform:** Benefits and limitations of each
- **Applications of Waveform Analysis:** Synchronous Time Averaging (STA) for rolls in nip; Peak Hold averaging for maximum carrier/sideband frequency amplitudes for rolling element bearings; Time Difference cursors for identifying beat frequencies and repeating impacts (gear teeth cracks or defects); Transient Analysis of motor inrush current; Distinguishing Misalignment from Looseness using waveform analysis as a confirmation to the FFT data; and Gearbox Analysis using STA waveforms and standard waveform discontinuity analysis

#### Audience

Vibration technicians and reliability engineers

#### Prerequisites

Intermediate vibration analysis or eighteen-month vibration related field experience is recommended.

### Machinery Health Time Waveform Analysis – Virtual - 2051V CEUs – 2.1



#### Overview

This 3-day course is designed to upgrade and enhance waveform analysis skills for vibration technician and reliability engineers. There are several reasons that vibration analysts want to understand and use waveform analysis, since some significant defects are better analyzed in the time domain. The time domain provides visual confirmation of amplitude enhancement and reduction. Time waveform analysis can present, in a static picture, amplitude variations and changes in frequencies that the FFT cannot display without using multiple (dynamic) graphics. Further, a waveform graphically presents accurate peak vibration amplitudes representing defect severity.

#### Topics

- **Waveform Data Acquisition:** Analog to Digital Conversion (A/D)
- **Waveform Parameters for Trending:** Peak to Peak, Crest Factor, and Analog Overall
- **Waveform Tools:** Revolution Markers, Difference Frequency markers, Phase, Peak, RMS, Crest Factor
- **Waveform Patterns:** Sinusoidal, Impacting, Truncated, Asymmetric, Transient/Random, Modulated and Discontinuity or Bad/Compromised Data.

### 2051V – Continued...

- **FFT vs. Waveform:** Benefits and limitations of each
- **Applications of Waveform Analysis:** Synchronous Time Averaging (STA) for rolls in nip; Peak Hold averaging for maximum carrier/sideband frequency amplitudes for rolling element bearings; Time Difference cursors for identifying beat frequencies and repeating impacts (gear teeth cracks or defects); Transient Analysis of motor inrush current; Distinguishing Misalignment from Looseness using waveform analysis as a confirmation to the FFT data; and Gearbox Analysis using STA waveforms and standard waveform discontinuity analysis

### Machinery Health Laser Alignment for AMS 2140 - 2096 CEUs - 1.8

#### Overview

The 2.5-day course provides training on shaft alignment using Emerson's laser alignment product line with focus on the AMS 2140 Machinery Health™ Analyzer. This course includes hands-on training with horizontal alignment and vertical alignment demonstrators and covers management of an alignment program using the AMS Machinery Manager software.

#### Topics

- Alignment: What is it? Why?
- Required pre-shutdown checks
- Pre-alignment checks and corrections
- The science and art of alignment
- Tools & techniques for moving equipment
- Time-savers
- User of laser alignment product line with AMS 2140 Machinery Health™ Analyzer
- Alignment information
- Management systems: methods and advantages

#### Audience

This 2.5-day class is intended for personnel who have limited or no alignment experience.



### Machinery Health Vibration Analysis Category IV – Advanced - 2044 CEUs – 3.2

#### Overview

This 4-day class will provide the attendee with a solid background on how a data collector, FFT analyzer, functions. It will provide necessary information on how the FFT process works and how the end user can use the instrument to its' full capabilities. Students will learn the strengths and limitations of the modern data (FFT) collector.

Demonstrations will be performed to reinforce training topics. Lab calculations will be performed by the students throughout the course to reinforce topics learned in the class. This course is part two of the two courses required for the Category IV Vibration Analyst examination.

#### Topics

- Basic Navigation
- The FFT Analyzer
  - Resolution
  - Dynamic Range
  - Window Effects
  - Overlap
  - Filtering
  - Accuracy of the amplitudes and frequencies versus window effects
  - Averaging
- Modulation
- Beats
- Multi-Channel Analysis
- Transient Data Analysis
  - Nyquist Plots
  - Bode Plots
  - Waterfall Plots
- Impact Testing
  - Natural Frequencies
  - Mode Shapes versus Operating Deflection
  - Stiffness from Impact Testing
  - Methods of calculating Damping From "Q" Factor
  - Modal Analysis

#### Audience

Vibration analysts seeking Category IV certification

#### Prerequisites

Machinery Health - Rotor Dynamic Analysis for Vibration Analysts - Basic - 2034

### Machinery Health Vibration Analyst Exam Category IV - 2024EX

#### Overview

Test Format: Written exam

Duration: 5 hours

Passing Grade: 70%Eligibility for

Examination:

- Minimum Duration of Training (hours): Category III + 64
- Minimum Duration of Cumulated Experience (months): 60
- Has taken and passed the Category III exam.

### Machinery Health Online Protection Operation & Maintenance– 2080 CEUs - 2.1

#### Overview

This 3-day course is a hands-on training for anyone involved with operating and maintaining an Online Protection System. Workshops include practice with "live" monitors and racks.

#### Topics

- Overview of hardware components  
Rack configuration Operator display software
- Data acquisition software Interface with the On-line prediction system
- System troubleshooting and maintenance.

#### Audience

This 3-day course is a hands-on training for anyone involved with operating and maintaining an AMS 6500 Protection System.

### Machinery Health AMS Online Prediction Operation & Maintenance – 2088 CEUs - 2.8

#### Overview

This 4-day course best suits those who have a CSI 4500, AMS 6500, AMS 2600 or XP32 system installed and operational prior to attending the course.

#### Topics

- Vibration basics and terminology relating to the CSI 4500, AMS 6500, AMS 2600 or XP32
- System overview: functionality and system components
- Online Watch - used to monitor the system daily
- Online Config - adding a new machine to an existing database
- Vibration Analysis Module - spectrums, waveforms and trend data
- PEAKVUE™ technology Processing
- Transient setup and capture evaluation
- Review of customer databases

#### Audience

- System users or analysts
- Personnel using the CSI 4500, AMS 6500, AMS 2600 or XP32 daily
- Those responsible for configuring databases and analyzing data

#### Prerequisites

Knowledge of vibration and industrial machinery is helpful, but not necessary.

### Machinery Health Lubrication – Introduction & Intermediate - 2082 CEUs - 2.1

#### Overview

Guidelines and instruction for starting an oil analysis program will be provided in this 3-day course. The course focuses on the basic properties of lubricants and lubricant specifications including additive packages. An overview of laboratory testing methods and interpretation of test data is taught. In addition, instruction is provided on proper storage and handling of new, unused lubricants, as well as sample point

identification and best practices for collecting samples from machinery. Basic contamination control and wear debris analysis and identification is covered. The focus of the level two portion of the course is the use of oil analysis with other predictive technologies to enhance a machinery health program. Machine life extension and reduction of unscheduled downtime will be covered in depth. Training includes introductions to lubricant engineering, failure concepts, and failure prevention. Information will be provided on greases and synthetic lubricants, including advantages and applications. The importance of Wear Debris Analysis and contamination control and their impact on reliability will be stressed. Guidelines and step-by-step procedures will be offered for consolidating lubricants, setting alarm limits, as well as managing and enhancing existing lubrication programs. Optional Level I & Level II Lubrication Certification exams will be administered at the end of the course for no charge.

#### Topics

- The productive lubricant analysis program
- Analyzing oil data
- Identifying common types of wear debris, their origins, and corrective actions
- The importance of contamination control
- Designing sampling, storage and handling procedures
- The components of RBM lubrication program
- Methods for extending machine life
- The importance of Wear Debris Analysis and
- Contamination Control
- Lubricant consolidation
- Establishing alarms

#### Audience

This course is designed for individuals who have limited or no oil analysis experience.

### Machinery Health AMS 6500 ATG Operation & Maintenance – 2086 CEUs - 2.1

#### Overview

This 3-day hands-on training course is for any user or analyst involved with operating and maintaining an AMS 6500 ATG System. Workshops include practice with module and software configuration.

#### Topics

- Overview of hardware and modules
- Rack and module configuration
- Machine Studio software functionality, navigation and configuration
- System troubleshooting and maintenance
- ATG View App

#### Audience

This 4-day course is a hands-on training for anyone involved with operating and maintaining an AMS6500 ATG System.

**Machinery Health Lubrication –  
Introduction & Intermediate – Virtual -  
2082V  
CEUs - 2.1**



**Overview**

Guidelines and instruction for starting an oil analysis program will be provided in this 3-day course. The course focuses on the basic properties of lubricants and lubricant specifications including additive packages. An overview of laboratory testing methods and interpretation of test data is taught. In addition, instruction is provided on proper storage and handling of new, unused lubricants, as well as sample point identification and best practices for collecting samples from machinery. Basic contamination control and wear debris analysis and identification is covered. The focus of the level two portion of the course is the use of oil analysis with other predictive technologies to enhance a machinery health program. Machine life extension and reduction of unscheduled downtime will be covered in depth. Training includes introductions to lubricant engineering, failure concepts, and failure prevention. Information will be provided on greases and synthetic lubricants, including advantages and applications. The importance of Wear Debris Analysis and contamination control and their impact on reliability will be stressed. Guidelines and step-by-step procedures will be offered for consolidating lubricants, setting alarm limits, as well as managing and enhancing existing lubrication programs. Optional Level I & Level II Lubrication Certification exams will be administered at the end of the course for no charge.

**Topics**

- The productive lubricant analysis program
- Analyzing oil data
- Identifying common types of wear debris, their origins, and corrective actions
- The importance of contamination control
- Designing sampling, storage and handling procedures
- The components of RBM lubrication program
- Methods for extending machine life
- The importance of Wear Debris Analysis and
- Contamination Control
- Lubricant consolidation
- Establishing alarms

**Audience**

This course is designed for individuals who have limited or no oil analysis experience

**Machinery Health Wear Debris Analysis – 2084**

**CEUs - 1.4**

**Overview**

Wear debris analysis is often referred to as the most important form of oil analysis. This 2-day course teaches how to apply conditions such as the environment and other outside factors to make an accurate root cause analysis. Attendees gain a basic understanding of wear particle generation, sample preparation techniques, identification and characterization of wear particles. Data generated using the OilView® instrumentation and how it applies to WDA is discussed as well as the use of the OilView® WDA module. WDA skills must be maintained by the student through regular practice and may be developed by reading further on the subject.

**Topics**

- Theory Presentation
- Wear Particle Generation
- Tribology, Friction, and Wear
- Lubrication Fundamentals
- Sample Screening: Discussion of How to I/Je Preliminary Data and Equipment type to Select WDA Candidates and Sample Preparation Techniques
- Interpretation of Oil Analysis Results Related to WDA such as OilView Indices and Commercial Oil Laboratory Data
- Sample Preparation Techniques: Discussion of Sample Preparation for Grease, Oil, Hydraulic Fluid, and Synthetics
- Disciplined and Systematic Approach to WDA: Overview of the OilView WDA Module
- Particle Identification and Characterization Exercise
- Identification and Characterization of Wear Debris

**Machinery Health Electric Motor  
Diagnostics & MotorView – Introduction  
- 2081**

**CEUs - 2.8**

**Overview**

This 4-day course is intended for personnel who are experienced in vibration analysis and diagnostics and focuses on the theoretical concepts of motor diagnostics. This course uses labs and case histories to demonstrate the functionality of the MotorView software in determining rotor bar defects using current and flux data. This course is designed for mechanical and electrical skilled personnel who may not have a background in motor theory, operation and construction.

**Topics**

- Basic electrical principles
- AC/DC motor theory and design
- Variable frequency drives
- Data collection methods

- Current spectra and waveform analysis
- Flux spectra analysis and data evaluation
- Temperature data
- Shaft current
- Analysis of case histories
- Windows configuration for MotorView operation

**Audience**

The MotorView course is designed for students who are experienced in vibration analysis and diagnostics and focuses on the theoretical concepts of motor diagnostics.

**Machinery Health Turbomachinery  
Diagnostics – 2089**

**CEUs - 2.8**

**Overview**

This 4-day course is designed for engineers, supervisors, managers and rotating equipment support professionals responsible for the operation and maintenance of various sizes of turbines. This course will assist these professionals with their analysis of vibration problems on turbines. The effects of operating parameters on turbine vibration and how understanding the operating parameters can assist with the diagnosis of turbine problems is discussed. Case histories will be presented to reinforce class topics and facilitate class discussion.

**Topics:**

- Types of turbine monitoring systems
- Sensor location and installation
- Types of turbine bearings
- Turbine operating parameters
- Turbine data analysis
- Turbine balancing

**Prerequisites:** Knowledge and/or experience on vibration data collection and analysis techniques are highly recommended.

### METCO Metering Appreciation - M2610 CEUs - 0.8

#### Overview

This 1-day course delivers an overview understanding of custody transfer flow measurement, together with the basic concepts of metering techniques and the function of flow computers.

#### Topics

- Why Meter?
- Metering Techniques
- Understanding Flow Computers
- Allocation Appreciation
- Reporting Procedures
- The Audit Trail. Operating
- Fault Conditions

#### Audience

This course is intended for those who are not working with metering but have an involvement that requires an insight into metering to carry out their own job. Typical job functions include: plant operators and technical assistants. Also applicable to: line managers, supervisors, engineers, commercial analysts and hydrocarbon accountants.

#### Prerequisites

No specialist metering knowledge is necessary for attendance on this course

### METCO Hydrocarbon Liquid & Natural Gas Flow Measurement - M2650 CEUs - 2.4

#### Overview

This 3-day course addresses the concepts of custody transfer metering, principle of allocation in shared facilities, and the general operating principles of custody transfer instruments in both Natural Gas and Hydrocarbon Liquid Flow Metering.

#### Topics

- Why Meter?
- Traceability
- Uncertainty
- Allocation
- Flow Computer Overview
- Liquid Metering
- Meter Proving
- The Fast Loop
- Liquid Densitometers
- Automatic Sampling
- BS&W
- Gas Metering
- Gas Characteristics
- Gas Flow Meters
- Gas Metering Instrumentation
- The Gas Densitometer
- The Gas Chromatograph
- Dewpoint
- Wet Gas Metering
- The Audit Trail
- Procedures

#### Audience

This course is intended for those who are involved with metering but may not be metering specialists. Typical job functions include: maintenance technicians, supervisors and engineers.

#### Prerequisites

A basic knowledge of metering operations or maintenance is necessary for attendance for this course.

### METCO Measurement Uncertainty Training - M2662 CEUs – 1.6

#### Overview

This 2-day course addresses the general principles of uncertainty, statistical methods, uncertainty techniques, mathematics of uncertainty and equipment uncertainties.

A sample of the contents is shown below:

#### Topics

- Explain Accuracy versus Uncertainty
- Define Error versus Uncertainty
- Explain Accuracy & Repeatability
- Explain Tolerance & Uncertainty
- Random & Systematic Uncertainties
- Standard Uncertainty
- Relative Uncertainty
- Combined Standard Uncertainty
- Combined Relative Uncertainty
- Expanded Uncertainty
- Relative Expanded Uncertainty
- Root Sum Square (Quadrature Method)
- Monte Carlo Simulation (Stochastic Approach)
- Perturbation Method (Finite Differences)
- Multiplied Terms
- Divided Terms
- Square & Square Root Terms
- Parallel Streams commingling
- Measurement by Difference

#### Audience

This course is intended for those who carry out uncertainty calculations on flow measurement systems or have to interpret them. Typical job functions: senior measurement specialists, measurement engineers, measurement consultants.

#### Prerequisites

Before this training course the candidate should have a good measurement and mathematical background

### METCO Measurement Auditing – Introduction - M2665

#### CEUs - 1.6

#### Overview

This 2-day course is designed to give appreciation of the audit process.

#### Topics

- Introduction to Auditing
- Why Audit
- Audit Types
- The Audit Body
- ISO 9001 — Quality Management
- Measurement System Risk
- The Audit Process
- Audit Criteria
- Auditor Responsibilities
- Conducting the Audit
- Audit Reporting and Follow-up

#### Audience

This course is intended for those who arrange and deal with auditors carrying out audits on flow measurement systems, who have to respond to audit findings and represent their companies whilst witnessing an audit. Typical job functions: measurement specialists, measurement engineers, measurement consultants, contract managers, operations managers.

#### Prerequisites

A level of measurement knowledge will be required.

### METCO Measurement Uncertainty Training - M2662

#### CEUs – 1.6

#### Overview

This 2-day course addresses the general principles of uncertainty, statistical methods, uncertainty techniques, mathematics of uncertainty and equipment uncertainties.

A sample of the contents is shown below:

#### Topics

- Explain Accuracy versus Uncertainty
- Define Error versus Uncertainty
- Explain Accuracy & Repeatability
- Explain Tolerance & Uncertainty
- Random & Systematic Uncertainties
- Standard Uncertainty
- Relative Uncertainty
- Combined Standard Uncertainty
- Combined Relative Uncertainty
- Expanded Uncertainty
- Relative Expanded Uncertainty
- Root Sum Square (Quadrature Method)
- Monte Carlo Simulation (Stochastic Approach)
- Perturbation Method (Finite Differences)
- Multiplied Terms
- Divided Terms
- Square & Square Root Terms
- Parallel Streams commingling
- Measurement by Difference

### M2662 – Continued...

#### Audience

This course is intended for those who carry out uncertainty calculations on flow measurement systems or have to interpret them. Typical job functions: senior measurement specialists, measurement engineers, measurement consultants.

#### Prerequisites

Before this training course the candidate should have a good measurement and mathematical background

### METCO Measurement Technician – Intermediate - M2667

#### CEUs - 2.4

#### Overview

This 3-day course delivers an overall understanding of oil and Gas process, custody transfer metering and the role and responsibilities of the Metering technician.

#### Topics

- Oil and Gas Process
- Flow Meters (Orifice, turbine, coriolis, venturi, magflow, vortex)
- Pressure, temperature differential pressure
- Density
- Oil and Gas sampling
- BS & W measurement
- Chromatography
- Flow Computers
- Reports
- Planned Maintenance
- Calibrations
- Calibration Software
- Logistics and spares management]
- P &ID's
- Loop Diagrams

#### Audience

This course is intended for metering specialists, Trainee Metering Specialist and Instrument Specialist. Typical job functions include; maintenance technicians, Instrument Technicians.

#### Prerequisites

A good knowledge of process instrumentation or maintenance is necessary for attendance for this course.

### METCO Measurement Auditing - Advanced - M2668

#### CEUs - 2.8

#### Overview

This 4-day course is designed to give an outcome such that the candidate will be able to carry out shadowed audits and go on to complete 3rd party audits.

#### Topics

- Introduction to Auditing
- The Audit Body
- The Auditor
- The Audit Process
- Audit Criteria
- HM 60- Guidelines for Auditing of Measurement systems
- Auditor Responsibilities

### M2668 – Continued...

#### Audience

This course is intended for those who carry out audits on flow measurement systems. Typical job functions: senior measurement specialists, measurement engineers, measurement consultants.

#### Prerequisites

Before this training course the candidate will have successfully completed the ISO 9001 Lead Auditors training.

### METCO Measurement Management – Intermediate - M2678

#### CEUs – 2.4

#### Overview

This 3-day course delivers an overall understanding of Liquid & Custody Transfer and Allocation Measurement and the role and responsibilities of the Measurement Site Management.

#### Topics

- International Standards in use
- The Flow Computer and HMI
- Flow Computer calculations and input verification
- The Flowmeter – USM, Coriolis & Turbine Meter
- Meter Proving and Flowmeter verification / recertification
- Pressure and Temperature Measurement
- Densitometers
- Liquid Sampling & BS&W measurement
- Instrument verification and recertification
- Typical fault handling
- The Audit Trail
- The Support Engineer Role
- Data Communication
- Daily Reports
- Historian software overview
- Mismeasurement handling
- Recertification and Revalidation
- Spares Management
- Procedures – Operational and Maintenance
- Maintenance Routine Frequencies
- Management of Training
- Management of Competency
- Management of a Measurement Audit

#### Audience

This course is intended for Measurement Engineers and Instrument Engineers or Technical Authorities who manage flow measurement systems, and would be useful for Graduate or Trainee engineers expecting to be working on these systems

#### Prerequisites

A level of measurement or instrument knowledge will be required.



**Micro Motion Coriolis & Rosemount  
8700 Series Smart Magnetic Flowmeters  
– Introduction - 2384  
CEUs - 0.7**

**Overview**

This 1-day field class provides hands-on training on both the Coriolis and Magnetic Flowmeters. Typically, 2/3 of the course time is spent on Micro Motion's Coriolis meter and 1/3 on Rosemount's 8700 Magnetic Flowmeter. Theory of operation, meter components and installation of each flowmeter are covered. The focus of the class is to provide a hands-on experience configuring and troubleshooting best practices. Students will learn the Micro Motion Series 1000/2000 transmitters using one of these configuration tools; Prolink III, HC475, AMS Device Manager or Series 3000 display interface devices. Public field classes typically use Prolink III for configuring the Micro Motion transmitters and the HC475 will be used for the Rosemount 8700 Magnetic flowmeter. Customers can choose which configuration device is used for classes held at their site.

**Topics**

After attending the course, the student will be able to do the following for both Micro Motion's Coriolis and Rosemount 8700 Magnetic flowmeters:

- Briefly Explain the Fundamentals for How Each Flowmeter Works and the Function of the Key Components
- Basic Understanding of the Installation Best Practices for Orienting, Mounting and Wiring the Sensor and Transmitter
- Perform a Basic Configuration of the Metering System for Various Applications
- Diagnose and Know How to Correct the Most Common Meter and Process Issues

**Audience**

This combined class is intended anyone that is involved with properly configuring and troubleshooting a Micro Motion flow and density meter and Rosemount 8700 Smart Magnetic Flowmeters. Typical job functions include; maintenance technicians, instrument technicians and instrumentation engineers.

**Prerequisites**

Some prior experience working with Micro Motion Coriolis & Rosemount 8700 Magnetic flowmeters is recommended. However, students with no past experience can also benefit. A basic understanding of the fundamentals of flow measurement, electricity, analog and frequency signal processing is assumed.

**Micro Motion Coriolis & Rosemount  
8800 Series Smart Vortex Flowmeters –  
Introduction - 2387  
CEUs - 0.7**

**Overview**

This 1-day field class provides hands-on training on both the Coriolis and Vortex Flowmeters. Typically, 2/3 of the course time is spent on Micro Motion's Coriolis meter and 1/3 on Rosemount's 8800 Vortex Flowmeter. Theory of operation, meter components and installation of each flowmeter are covered. The focus of the class is to provide a hands-on experience configuring and troubleshooting best practices. Students will learn the Micro Motion Series 1000/2000 transmitters using one of these configuration tools; Prolink III, HC475, AMS Device Manager or Series 3000 display interface devices. Public field classes typically use Prolink III for configuring the Micro Motion transmitters and the HC475 will be used for the Rosemount 8800 Vortex flowmeter. Customers can choose which configuration device is used for classes held at their site.

**Topics**

Students will be able to do the following for both Micro Motion's Coriolis and Rosemount 8800 Vortex flowmeters:

- Briefly Explain the Fundamentals for How Each Flowmeter Works and the Function of the Key Components
- Have a Basic Understanding of the Installation Best Practices for Orienting, Mounting and Wiring the Sensor and Transmitter
- Perform a Basic Configuration of the Metering System for Various Applications
- Diagnose and Know how to Correct the Most Common Meter and Process Issues
- Configure the Metering System to Measure Available Process Variables from the Device for Their Application
- Learn a Step by Step Process to Perform Basic Troubleshooting of the Most Common Meter and Process Issues

**Audience**

This combined class is intended anyone that is involved with properly configuring and troubleshooting a Micro Motion flow and density meter and Rosemount 8800 Micro Motion - Coriolis & Rosemount 8800 Vortex Flowmeters - 2387

**Prerequisites**

Some prior experience with Micro Motion Coriolis & Rosemount 8800 Vortex flowmeters. A basic understanding of the fundamentals of flow measurement, electricity, analog and frequency signal processing.

**Micro Motion Coriolis Product –  
Intermediate - 2358  
CEUs - 0.7**

**Overview**

This one-day course consists of a blend of lectures and hands-on exercises that cover the installation, configuration, calibration checks and troubleshooting of Micro Motion sensors with the Series 1000/2000 transmitters and peripherals. This course includes hands-on exercises. Courses held at customer specified sites can be customized to address specific transmitters and configuration tools. Public registration classes cover a broader range of equipment based on the needs of the attendees.

After completing this training, students will also get unlimited access to the Micro Motion's Online Training (e1010,e1011,e1012,e1013,e1014) for a year. This online training cost \$400/license per year if purchased separately.

**Topics**

- Explain the Fundamentals for how a Micro Motion Coriolis Meter Works and the Function of the Key Components
- Be able to apply the installation best practices for orienting, mounting and wiring the sensor and transmitter
- Configure the Metering System to Measure Available Process Variables from the Device for Their Application
- Learn a Step by Step Process to Perform Basic Troubleshooting of the Most Common Meter and Process Issues

**Audience**

This course is intended for anyone that is involved with properly installing, wiring, configuring and troubleshooting a Micro Motion Coriolis flow and density meter. Typical job functions include; maintenance technicians, instrument technicians and instrumentation engineers.

**Prerequisites**

A basic understanding of the fundamentals of flow measurement, electricity, analog & frequency signal processing is assumed.



### Micro Motion Coriolis Product – Intermediate - 2358 CEUs - 0.7



#### Overview

This one-day course consists of a blend of lectures and hands-on exercises that cover the installation, configuration, calibration checks and troubleshooting of Micro Motion sensors with the Series 1000/2000 transmitters and peripherals. This course includes hands-on exercises. Courses held at customer specified sites can be customized to address specific transmitters and configuration tools. Public registration classes cover a broader range of equipment based on the needs of the attendees.

After completing this training, students will also get unlimited access to the Micro Motion's Online Training (e1010,e1011,e1012,e1013,e1014) for a year. This online training cost \$400/license per year if purchased separately.

#### Topics

- Explain the Fundamentals for how a Micro Motion Coriolis Meter Works and the Function of the Key Components
- Be able to apply the installation best practices for orienting, mounting and wiring the sensor and transmitter
- Configure the Metering System to Measure Available Process Variables from the Device for Their Application
- Learn a Step by Step Process to Perform Basic Troubleshooting of the Most Common Meter and Process Issues

#### Audience

This course is intended for anyone that is involved with properly installing, wiring, configuring and troubleshooting a Micro Motion Coriolis flow and density meter. Typical job functions include; maintenance technicians, instrument technicians and instrumentation engineers.

#### Prerequisites

A basic understanding of the fundamentals of flow measurement, electricity, analog & frequency signal processing is assumed.

### Micro Motion Coriolis Product – 2352 CEUs - 2.1

#### Overview

This three-day class consists of a blend of lectures and hands-on exercises that cover the installation, configuration, and calibration of the Micro Motion metering system. Students will learn the Series 1000/2000 transmitters using ProLink® III, HC475 and the Series 3000 interface devices. Students will perform a master reset and use ProLink III to configure the Series 1000/2000, perform a flow calibration and solve troubleshooting problems. On the third day, based on student need, we will cover one or all of the following topics: RFT9739 transmitter, T-Series, R-Series and Series 3000 platform and an introduction to the new Micro Motion's 5700's transmitter. Students will also learn the Modbus communications model, including RS-485 network requirements, memory structure, data types, functions, character framing, and message framing.

After completing this training, students will also get unlimited access to the Micro Motion's Online Training (e1010,e1011,e1012,e1013,e1014) for a year. This online training cost \$400/license per year if purchased separately.

#### Topics

After attending this course the student will be able to do the following:

- Be able to explain the fundamentals for how a Micro Motion Coriolis meter works and the functions of the key components
- Be able to apply the installation best practices for orienting, mounting and wiring the sensor and transmitter
- Be able to configure the metering system to measure flow, density and temperature for the application
- Be able to apply a step-by-step process to perform basic troubleshooting for the most common meter and process issues
- Be able to explain the fundamentals for the Modbus protocol model.
- Be able to configure, commission, read process data, view & analyze key diagnostic registers and loop test a batch application using a Micro Motion Meter.

#### Audience

This class is intended for anyone that is involved with properly installing, wiring, configuring and troubleshooting a Micro Motion Coriolis flow and density meter. Typical job functions include; maintenance technicians, instrument technicians and instrumentation engineers.

#### Prerequisites

None required. However, basic understanding of the fundamentals of flow measurement, electricity, analog & frequency signal processing are assumed.

### Micro Motion Coriolis Product – 2380 CEUs - 1.4

#### Overview

This two-day class is modeled after the 2352 factory course. It consists of a blend of lectures and extensive hands-on exercises that cover the installation, configuration and calibration of the Micro Motion metering system. Students will learn the Series 1000/2000 transmitters using either ProLink® III, AMS Device Manager, HC475 or L.O.I. Students will perform a master reset, configure the Series 1000/2000, perform a flow calibration and solve troubleshooting problems. Based on student need, we will cover one or all of the following topics: RFT9739, 9739MVD transmitter, T-Series, R-Series, or Series 3000 platform. Onsite classes can be customized to cover the customer's installed base, preferred configuration tools and application questions. This course also includes an introduction to Micro Motion's new 5700 transmitter. After completing this training, students will also get unlimited access to the Micro Motion's Online Training (e1010,e1011,e1012,e1013,e1014) for a year. This online training cost \$400/license per year if purchased separately.

#### Topics

- Explain the Fundamentals for how a Micro Motion Coriolis Meter Works and the Function of the Key Components
- Learn the Installation Best Practices for Orienting, Mounting and Wiring the Sensor and Transmitter
- Configure the Metering System to Measure Flow, Density and Temperature for Various Applications
- Learn a Step by Step Process to Perform Basic Troubleshooting of the Most Common Meter and Process Issues

#### Audience

This class is intended for anyone that is involved with properly installing, wiring, configuring and troubleshooting a Micro Motion flow and density meter. Typical job functions include; maintenance technicians, instrument technicians and instrumentation engineers.

#### Prerequisites

Basic understanding of the fundamentals of flow measurement, electricity, analog and frequency signal processing are assumed.

### Micro Motion - Coriolis RFT9739/9739MVD Training Class – 2385 CEU – 0.7

#### Overview

This 1-day course consists of a blend of lectures and hands-on exercises that cover the installation, configuration, calibration checks and troubleshooting of Micro Motion ELITE, F-Series and D sensors with the RFT9739 or 9739MVD transmitters and peripherals. This course includes hands-on exercises. Courses held at customer specified sites can be customized to address specific transmitters and configuration tools. Public registration classes cover a broader range of equipment based on the needs of the attendees.

#### Topics

After attending this course, the student will be able to do the following:

- Explain the Fundamentals for how a Micro Motion Coriolis Meter works and the Function of the Key Components
- Learn the Installation Best Practices for Orienting, Mounting and Wiring the Sensor and Transmitter
- Configure the RFT9739 or 9739MVD to Measure Flow, Density and Temperature for Their Application
- Learn a Step by Step Process to Perform Basic Troubleshooting of the Most Common Meter and Process Issues

#### Audience

This course is intended for anyone that is involved with properly installing, wiring, configuring and troubleshooting a Micro Motion Coriolis flow and density meter. Typical job functions include; maintenance technicians, instrument technicians and instrumentation engineers

#### Prerequisites

None required. However, basic understanding of the fundamentals of the behavior/properties of gases and gas density measurement are helpful. Basic electricity, analog & frequency signal processing knowledge are also assumed.

### Micro Motion Coriolis Flowmeters - Introduction - 2339C CEUs - 0.40

#### Overview

This half day course is a condensed version of the 2358 course. This course briefly reviews the theory of operation, meter components and installation. The focus of the class is to provide a hands-on experience configuring the Micro Motion metering system. Students will learn the Series 1000/2000 transmitters using one of these configuration tools: ProLink III, HC475, AMS Device Manager or the local operator interface. Public classes typically use ProLink III. Customers can choose which device is used for classes held at their site. This course also includes an introduction to Micro Motion's new 5700 transmitter.

After completing this training, students will also get unlimited access to the Micro Motion's Online Training (e1010,e1011,e1012,e1013,e1014) for a year. This online training cost \$400/license per year if purchased separately.

#### Topics

- Briefly Explain the Fundamentals for How a Micro Motion Coriolis Meter Works and the Function of the Key Components
- Have a basic understanding of the Installation Best Practices for Orienting, Mounting and Wiring the Sensor and Transmitter
- Perform a Basic Configuration of the Metering System to Measure Flow, Density and Temperature for Various Applications
- Diagnose and Know how to Correct the Most Common Meter and Process Issues

#### Audience

This class is intended as a refresher course for anyone that is involved with properly configuring and troubleshooting a Micro Motion flow and density meter. Typical job functions include; maintenance technicians, instrument technicians and instrumentation engineers. This class is also intended to be taught as two, 1/2-day repeat sessions to accommodate customers who need to train their entire department but must also maintain the operation of their plant by scheduling their employees between an AM/PM training sessions.

#### Prerequisites

Some prior experience working with Micro Motion Coriolis meters is recommended. Students with no past experience can benefit if their learning objectives are to get a basic intro to operation, installation, configuration and troubleshooting. For all attendees, it is assumed they have a basic understanding of the fundamentals of flow measurement, electricity, analog and frequency signal processing.

### Micro Motion Coriolis, Rosemount 8700 Magnetic & 8800 Vortex Wireless – 2383 CEUs - 0.70

#### Overview

This 1-day course consists of a blend of lectures and hands-on exercises that cover a basic overview of wireless capabilities with a Micro Motion Coriolis, Rosemount 8700 Series Magnetic and 8800 Series Vortex meters. Based on customer need, the class can be taught for each of the individual products. The course provides a step by step process for the following: how to install and wire a 775 Smart Wireless THUM to each transmitter, how to configure the THUM, how to configure the 1420 Wireless Gateway to the THUM using AMS Device Manager and how to add and view the Micro Motion and Rosemount transmitters to the gateway.

#### Topics

- Explain the Fundamentals for how a Micro Motion Coriolis, Rosemount 8700 Series Magnetic & 8800 Series Vortex Flowmeters Work with a 1420 Wireless Gateway and 775 Smart THUM Adapter
- Install and Wire a 775 Smart THUM to Micro Motion and Rosemount Transmitters
- Connect to and Configure the Micro Motion and Rosemount Transmitters to work with a 1420 Wireless Gateway
- Configure a 775 Smart THUM and the Transmitters to Communicate on the Gateway using AMS Device Manager

#### Audience

This course is intended for anyone that is involved with installing, wiring, configuring and troubleshooting a Micro Motion Coriolis, Rosemount 8700 Magnetic & 8800 Vortex flowmeters with a 775 Wireless THUM. Typical job functions include; maintenance technicians, instrument technicians and instrumentation engineers.

#### Prerequisites

General understanding of the HART® protocol and operation and configuration of a Micro Motion Coriolis, Rosemount 8700 Magnetic and 8800 Vortex meters is assumed.

### Micro Motion Density & Viscosity Product – Intermediate - 5708 CEUs - 1.40

#### Overview

This two-day course consists of a blend of lectures and hands-on exercises that cover the installation, configuration, calibration checks and troubleshooting of Micro Motion transmitters and peripherals. Courses held at customer specified sites can be customized to address specific transmitters and configuration tools. Public registration classes cover a broader range of equipment based on the needs of the attendees.

#### Topics

After attending this course, the student will be able to do the following:

- Explain the principle of operation for how a Micro Motion Density & Viscosity meter works and the function of the key components.
- Apply the installation best practices for orienting, mounting and wiring the sensor and transmitter.
- Configure the metering system to measure flow, density and temperature for their application.
- Apply a step by step process to perform basic troubleshooting of the most common meter and process issues.

### Micro Motion Coriolis Product – 5705 CEUs - 1.40

#### Overview

This two-day course consists of a blend of lectures and hands-on exercises that cover the installation, configuration, calibration checks and troubleshooting of Micro Motion transmitters and peripherals. The course includes hands-on exercises within the Inter Active Plant Environment training facility. Customer exclusive classes can be customized to address specific transmitter and configuration tools specific to that customer. This course also includes an introduction to Micro Motion's new 5700 transmitter.

#### Topics

After attending this course, the student will be able to do the following:

- Explain the principle of operation for how a Micro Motion Coriolis meter works and the function of the key components.
- Apply the installation best practices for orienting, mounting and wiring the sensor and transmitter.
- Configure the metering system to measure flow, density and temperature for their application.
- Apply a step by step process to perform basic troubleshooting of the most common meter and process issues.
- Experience hands on simulated plant environment with operating flow meters.

### Micro Motion Modbus Digital Communications – Intermediate - 2381 CEUs - 0.40

#### Overview

This 1/2-day class consists of a blend of lectures and hands-on exercises. Students will learn the Modbus communications model, including RS-485 network requirements, memory structure, data types, functions, character framing, and message framing. Students will use Micro Motion's Modbus documentation set and Modbus tool to configure transmitter features, read process data, reset totals, read and acknowledge alarms, analyze diagnostic registers, zero the flowmeter, perform a loop test and manage a batch process. Troubleshooting will also be covered.

#### Topics

- Explain the Fundamentals for the Modbus Protocol Model
- Configure, Commission, Read Process Data, View and Analyze Key Diagnostic Registers and Loop Test a Batch Application using a Micro Motion Meter
- Set up a Host System or PLC to Communicate with a Micro Motion Transmitter via Modbus

#### Audience

This course is appropriate for personnel who have any of the following responsibilities: Installing a Micro Motion transmitter on an RS-485 network, configuring, calibrating, operating, or troubleshooting a Micro Motion transmitter using Modbus protocol, setting up a Modbus host or PLC to communicate with a Micro Motion transmitter or writing programs that use Modbus protocol to communicate with Micro Motion transmitters.

#### Prerequisites

Students should have completed Micro Motion Comprehensive Product Training, Course 2352, or have equivalent knowledge or experience.

### Micro Motion Coriolis Configurable Transmitters - Intermediate – 5710 CEU - .7

#### Overview

This one-day course consists of a blend of lectures and hands-on exercises that cover the installation, configuration, calibration checks and troubleshooting of Micro Motion sensors with the Series 5700 transmitters and peripherals. This course includes hands-on exercises. Courses held at customer specified sites can be customized to address specific transmitters and configuration tools. Public registration classes cover a broader range of equipment based on the needs of the attendees.

After completing this training, students will also get unlimited access to the Micro Motion's Online Training (e1010,e1011,e1012,e1013,e1014) for a year. This online training cost \$400/license per year if purchased separately.

#### Topics

After attending this course, the student will be able to do the following:

- Be able to explain the principle of operation for how a Micro Motion Coriolis meter works and the function of the key components.
- Be able to apply the installation best practices for orienting, mounting and wiring the sensor and transmitter.
- Be able to configure the metering system to measure flow, density and temperature for their application.
- Be able to apply a step by step process to perform basic troubleshooting of the most common meter and process issues.

#### Audience

This one-day course is intended for anyone that is involved with properly installing, wiring, configuring and troubleshooting a Micro Motion Coriolis flow and density meter. Typical job functions include: maintenance technicians, instrument technicians and instrumentation engineers.

#### Prerequisites

None required. However, a basic understanding of the fundamentals of flow measurement, electricity, analog & frequency signal processing are assumed.

### Micro Motion Coriolis Configurable Transmitters - Introduction – 5711 CEU - .4

#### Overview

This half day course consists of a blend of lectures and hands-on exercises that cover the installation, configuration, calibration checks and troubleshooting of Micro Motion sensors with the Series 5700 transmitters and peripherals. This course includes hands-on exercises. Courses held at customer specified sites can be customized to address specific transmitters and configuration tools. Public registration classes cover a broader range of equipment based on the needs of the attendees.

After completing this training, students will also get unlimited access to the Micro Motion's Online Training (e1010,e1011,e1012,e1013,e1014) for a year. Applicable only for public registration. This online training cost \$400/license per year if purchased separately.

#### Topics

After attending this course, the student will be able to do the following:

- Be able to explain the principle of operation for how a Micro Motion Coriolis meter works and the function of the key components.
- Be able to apply the installation best practices for orienting, mounting and wiring the sensor and transmitter.
- Be able to configure the metering system to measure flow, density and temperature for their application.
- Be able to apply a step by step process to perform basic troubleshooting of the most common meter and process issues.

#### Audience

This half day course is intended as a refresher or a four hour introduction for anyone that is involved with properly installing, wiring, configuring and troubleshooting a Micro Motion Coriolis flow and density meter. Typical job functions include: maintenance technicians, instrument technicians and instrumentation engineers.

#### Prerequisites

This being a four-hour class, some prior experience working with Micro Motion meters is recommended. Students with no prior experience can also benefit from this course to provide a basic introduction. However, a basic understanding of the fundamentals of flow measurement, electricity, analog & frequency signal processing are assumed.

### Micro Motion Coriolis 5700 Ethernet Transmitter – 5712 CEU - .7

#### Overview

This one-day course consists of a blend of lectures and hands-on exercises that cover the installation, configuration and ethernet connection using the 5700 Ethernet transmitter. Additional common tasks like using Smart Meter Verification and downloading the Historian files for analysis are included. Emphasis is on how to tell if the transmitter is working and what to do when it is not working.

#### Topics

Learning Objectives: After attending this course the student will be able to do the following:

- Be able to install and power up the 5700 Ethernet transmitter.
- Be able to connect the transmitter to the ethernet network using existing topology
- Be able to configure the IP address as defined by the network administrator.
- Be able to connect to the on-board web server in the 5700 and configure the instrument.
- Be able to troubleshoot the network connection to determine if the transmitter is working properly.
- Be able to recognize common problems with the ethernet network and how to resolve them.

#### Audience

This one-day course is intended for anyone who may be tasked with the installation, maintenance or commissioning of the 5700 Ethernet transmitter.

#### Prerequisites

5700 Transmitter class (course # 5710 or 5711) or equivalent experience. A basic understanding of the fundamentals of flow measurement, electricity, analog & frequency signal processing is assumed.

### Micro Motion Specific Gravity Meter - Intermediate - 2386 CEUs - .7

#### Overview

This 1-day course consists of a blend of lectures and hands-on exercises that cover an overview of the operating principle, key components and applications of a 3098 Micro Motion Gas Specific Gravity meter. The process of commissioning a 3098 is covered including: installation, wiring, configuration and field calibration at initial startup. Troubleshooting of commonly seen issues is also covered. This course includes hands on demonstrations.

#### Topics

- Explain the Principle of Operation for how a Micro Motion 3098 Gas Specific Gravity Meter Works and the Function of the Key Components
- Learn the Installation Best Practices for Orienting, Mounting, Piping and Wiring the 3098
- Configure the 3098 and Perform the Required Field Calibration
- Learn a Step by Step Process to Perform Basic Troubleshooting of the Most Common Issues Customers Encounter

#### Audience

This course is intended for anyone that is involved with properly installing, wiring, configuring and troubleshooting a Micro Motion 3098 Gas Specific Gravity meter. Typical job functions include; maintenance technicians, instrument technicians and instrumentation engineers.

#### Prerequisites

None required. However, basic understanding of the fundamentals of the behavior/properties of gases and gas density measurement are helpful. Basic electricity, analog & frequency signal processing knowledge are also assumed.



### Micro Motion Coriolis Product - Advanced – 5713 CEUs: 2.1

#### Overview

This three-day course is intended for advanced users of Micro Motion Coriolis products who are responsible for the installation and commissioning, maintenance and troubleshooting and advanced operation of the equipment. The format is a mix of lecture and hands-on activities, heavily weighted toward the latter.

#### Topics

This course covers the following advanced topics:

- Theory of operation advanced topics.
- Advanced troubleshooting concepts, including performing and evaluating data logging.
- Theory of Zero, Zero offset and Zero verification.
- Custody Transfer and the use of Weights and Measures Software.
- Modbus Read/Writes and the use of the Modbus Interface Tool.
- Concentration Measurement.
- 5700 Historian Files, Downloading and Evaluation.
- Ethernet Basics
- Smart Meter Verification

After completing this training, students will also get unlimited access to the Micro Motion's Online Training (e1010,e1011,e1012,e1013,e1014) for a year. This online training cost \$400/license per year if purchased separately.

#### Audience

Typical job functions include: maintenance technicians, instrument technicians and instrumentation engineers.

#### Prerequisites

Students should have completed either Micro Motion 2358, 2380, or 2352 or have six months to a year of field experience in the use and maintenance of Micro Motion Coriolis products. A basic understanding of the fundamentals of flow measurement, electricity, analog & frequency signal processing is assumed.

### Micro Motion Compact Density Meter – Intermediate - 5714 CEUs:0.7

#### Overview

This one-day course consists of a blend of lectures and hands-on exercises that cover the installation, configuration, calibration checks and troubleshooting of Micro Motion transmitters and peripherals. Courses held at customer specified sites can be customized to address specific transmitters and configuration tools. Public registration classes cover a broader range of equipment based on the needs of the attendees.

#### Topics

After attending this course the student will be able to do the following:

- Explain the principle of operation for how a Micro Motion Compact Density meter works and the function of the key components.
- Apply the installation best practices for orienting, mounting and wiring the sensor and transmitter.
- Configure the metering system to measure flow, density and temperature for their application.
- Apply a step by step process to perform basic troubleshooting of the most common meter and process issues.

#### Audience

This one-day course is intended for anyone that is involved with properly installing, wiring, configuring and troubleshooting a Micro Motion Coriolis flow and density meter. Typical job functions include maintenance technicians, instrument technicians and instrumentation engineers.

#### Prerequisites

None

### Rosemount 8800 Series Smart Vortex Flowmeter - Introduction - 2339SV CEUs – 0.4

#### Overview

This 1/2-day field class is a condensed version of the 2341 course briefly reviewing the theory of operation, meter components and installation. The focus of the class is to provide a hands-on experience configuring and troubleshooting of the 8800 Vortex metering system. The students will learn the operation and capabilities of the Local Operator interface & HC475 and how to use these tools to perform configuration. Common issues encountered and troubleshooting techniques will also be covered.

#### Topics

- Explain the Differences and Capabilities of the Rosemount 8800 Series Vortex Flowmeters
- Explain the von Karman Effect and Principles of Operation of Vortex Flowmeters
- Identify Vortex Parts and Explain Functionality
- Configure and Test Transmitters using the AMS Device Manager
- Properly Install and Troubleshoot the Rosemount 8800 Series Vortex Flowmeter System

#### Audience

This class is intended as a refresher course for anyone that is involved with properly configuring and troubleshooting a Rosemount 8800 Series Smart Vortex Flowmeter. Typical job functions include; maintenance technicians, instrument technicians and instrumentation engineers. This class is also intended to be taught as two, 1/2 day repeat sessions to accommodate customers who need to train their entire department but must also maintain the operation of their plant by scheduling their employees between an AM/PM sessions.

#### Prerequisites

Some prior experience working with Micro Rosemount Vortex Flowmeters meters is recommended. However, students with no past experience can also benefit if their learning objectives are to get a basic introduction to operation, installation, configuration and troubleshooting. For all attendees, it is assumed they have a basic understanding of the fundamentals of flow measurement, electricity, analog & frequency signal processing.



**Micro Motion Coriolis Flow Meter  
Technology - Introduction - e1010  
CEU – 0.2**



**Overview**

This online training includes 2 sections. Coriolis flow meter technology overview and Coriolis flow meter installation best practice. In this course you will learn the benefits of using a Coriolis flow meter, the two main components of a Coriolis flow meter, the function of each key component of a Coriolis sensor, and how the Coriolis flow meter measures mass flow, density and temperature. You will also learn the considerations for determining sensor and transmitter location in a process, how to determine the best sensor orientation based on the application, and the best practices for mounting the sensor.

**Topics**

- Coriolis Flow Meter Technology Overview
- Coriolis Flow Meter Installation Best Practices

**Objectives**

- Explain the benefits of using a Coriolis flow meter.
- Identify the two main components of a Coriolis flow meter.
- Explain the function of each key component of a Coriolis sensor.
- Identify the Coriolis effect.
- Explain how the Coriolis flow meter measures mass flow, density and temperature
- Identify considerations for determining sensor and transmitter location in a process.
- Identify the best sensor orientation based on the application.
- Identify best practices for mounting the sensor.

**Audience**

This course is designed for personnel responsible for the installation, configuration, verification and maintenance of Micro Motion Coriolis flow meters.

Prerequisite

None

**Micro Motion Coriolis 2700 Transmitter  
Wiring & Configuration Tools -  
Intermediate - e1011  
CEU – 0.2**



**Overview**

This course includes 5 lessons:

1. Wiring Sensor to Transmitter
2. Connecting Power, Inputs & Outputs, Applying Power to the Transmitter
3. Wiring the Configuration Tools to the Transmitter
5. Navigation of Configuration Tools Menus

**Topics**

1. Wiring Sensor to Transmitter
2. Connecting Power, Inputs & Outputs, Applying Power to the Transmitter
3. Wiring the Configuration Tools to the Transmitter
4. Connecting Between the Configuration Tools & Transmitter
5. Navigation of Configuration Tools Menus

**Objectives**

- Explain how to prepare both ends of a four-wire cable for wiring a sensor to a transmitter.
- Explain how to install a cable between the sensor and the transmitter.
- Explain how connect AC and DC power supply wiring to the 2700 transmitter.
- Identify wiring connections to channel A, B and C.
- Identify which terminals to use for HART communication.
- Identify which terminals to use for Modbus communication.
- Identify which terminals are polarity sensitive.
- Explain how to establish communication using ProLink III, AMS and the HC475 with HART.
- Explain how to establish communication using ProLink III with Modbus.
- Identify the proper path through the ProLink III, AMS and HC475 menus to perform basic commissioning tasks.
- Explain how to perform these tasks using the configuration tool you use with your Micro Motion meters.

**Audience**

This course is designed for personnel responsible for the installation, configuration, verification and maintenance of Micro Motion Coriolis flow meters.

**Prerequisite**

None

**Micro Motion Coriolis 2700 Transmitter  
Configure Process Measurements -  
Intermediate - e1012**



**Overview**

This online training includes: Characterizing the Flowmeter, Configuring Flow Measurement for Liquids, Configuring Flow Direction and Damping, Configuring Density Measurement & Slug Flow Limits, and Configuring Temperature Measurement

**Topics**

- Characterizing the Flowmeter
- Configuring Flow Measurement for Liquids
- Configuring Flow Direction and Damping
- Configuring Density Measurement & Slug Flow Limits
- Configuring Temperature Measurement

**Objectives**

- Explain how to characterizing the Flowmeter
- Explain how to configuring Flow Measurement For Liquids
- Explain how to configuring Flow Direction and Damping
- Explain how to configuring Density Measurement & Slug Flow Limits
- Explain how to configuring Temperature Measurement

**Audience**

This course is designed for personnel responsible for the installation, configuration, verification and maintenance of Micro Motion Coriolis flow meters.

**Prerequisite**

None

**Micro Motion Coriolis 2700 Integrate the Meter with the System - Intermediate - e1013**  
CEU - 0.2



**Overview**

This online training includes: Configuring the Input & Output Channel Assignments, Configuring Milliamp Outputs, Configuring Frequency Output, Configuring Output Fault Conditions, Configuring Digital Communications, Performing a Loop Test, and Trimming Milliamp Outputs, if required

**Topics**

- Configuring the Input & Output Channel Assignments
- Configuring Milliamp Outputs
- Configuring Frequency Output
- Configuring Output Fault Conditions
- Configuring Digital Communications
- Performing a Loop Test
- Trimming Milliamp Outputs, if required

**Objectives**

- Explain how to Configure the Input & Output Channel Assignments
- Explain how to Configure Milliamp Outputs
- Explain how to Configure Frequency Output
- Explain how to Configure Output Fault Conditions
- Explain how to Configure Digital Communications
- Explain how to Perform a Loop Test
- Explain how to Trim Milliamp Outputs, if required

**Audience**

This course is designed for personnel responsible for the installation, configuration, verification and maintenance of Micro Motion Coriolis flow meters.

**Micro Motion Coriolis 2700 Configure Options & Final Checkout - Intermediate - e1014**  
CEU - 0.2



**Overview**

This online training includes 7 sections. Operating & Viewing Process Variables, Enabling & Disabling Actions and Security, Working with Process & Inventory Totals, Configuring Informational Parameters, Zeroing the Flowmeter, Final Checkout Under Process Conditions, and Backup/Save the Transmitter Configuration

**e1014 – Continued...**

**Topics**

- Operating & Viewing Process Variables
- Enabling & Disabling Actions and Security
- Working with Process & Inventory Totals
- Configuring Informational Parameters
- Zeroing the Flowmeter
- Final Checkout Under Process Conditions
- Backup/Save the Transmitter Configuration

**Objectives**

- Know how to operate & view process variables
- Know how to Enable & Disable Actions and Security
- Know how to Work with Process & Inventory Totals
- Know how to Configure Informational Parameters
- Know how to Zero the Flowmeter
- Know how to perform Final Checkout Under Process Conditions
- Know how to Backup/Save the Transmitter Configuration

**Audience**

This course is designed for personnel responsible for the installation, configuration, verification and maintenance of Micro Motion Coriolis flow meters.

**Prerequisite**

None

**Micro Motion Coriolis 5700 Transmitter Installation & Configuration - e1015**  
CEU - 0.2



**Overview**

This course contains an overview of the features and advantages of the Micro Motion Coriolis 5700 transmitter. It also includes how to install, characterize and configure the 5700 transmitter

**Topics**

- 5700 Transmitter Advantages
- 5700 Transmitter Features and Capabilities
- 5700 Transmitter Wiring and Installation
- 5700 Transmitter Characterization and Configuration

**Objectives**

- Understand the advantages of the Micro Motion Coriolis 5700 Transmitter
- Know the features and capabilities of the Micro Motion Coriolis 5700 transmitter

**e1015 – Continued...**

- Know how to use these features, such as the fully configurable and customizable display
- Understand how SMV works for the 5700 transmitter
- Know how to characterize and configure the 5700 Transmitter using the display and ProLink

**Audience**

This course is designed for personnel responsible for the installation, configuration, verification and maintenance of Micro Motion Coriolis flow meters.

**Micro Motion Coriolis 4200 Transmitter Characterize & Configure - Intermediate - e1016**  
CEU - 0.2



**Overview**

This course contains an overview of the features and advantages of the Micro Motion Coriolis 4200 transmitter. It also includes how to install, characterize and configure the 4200 transmitters.

**Objectives**

- Understand the advantages of the Micro Motion Coriolis 4200 Transmitter
- Know the features and capabilities of the Micro Motion Coriolis 4200 transmitter
- Know how to use these features, such as how to rotate the display
- Understand how SMV works for the 4200 transmitter
- Know how to characterize and configure the 4200 Transmitter using the display and ProLink

**Topics**

- 4200 Transmitter Advantages
- 4200 Transmitter Features and Capabilities
- 4200 Transmitter Wiring and Installation
- 4200 Transmitter Characterization and Configuration

**Audience**

This course is designed for personnel responsible for the installation, configuration, verification and maintenance of Micro Motion Coriolis flow meters

### Mimic Dynamic Simulation – 7601 CEUs – 2.1

#### Overview

In this 3-day course, students explore fundamental features of Mimic Simulation Software. The course focuses on installation and setup, building low and medium fidelity models, complete integration with a control system for configuration or logic checkout, operator training and instructor graphics creation. Completion of this class will enable the student to build a dynamic simulator and successfully integrate it with a control system.

#### Topics

- Mimic installation and overview
- Communications setup with Simulated IO Drivers
- Discrete and analog modeling
- Database generation utilities
- Development of training scenarios and snapshots using Mimic Operator Training Manager
- Software tools and options to increase efficiency
- System maintenance

#### Audience

This course is designed for process & process control engineers responsible for configuring and maintaining Mimic simulation software.

### Mimic Dynamic Simulation – Virtual – 7601V CEUs – 2.1



#### Overview

In this 3-day course, students explore fundamental features of Mimic Simulation Software. The course focuses on installation and setup, building low and medium fidelity models, complete integration with a control system for configuration or logic checkout, operator training and instructor graphics creation. Completion of this class will enable the student to build a dynamic simulator and successfully integrate it with a control system.

#### Topics

- Mimic installation and overview
- Communications setup with Simulated IO Drivers
- Discrete and analog modeling
- Database generation utilities
- Development of training scenarios and snapshots using Mimic Operator Training Manager
- Software tools and options to increase efficiency
- System maintenance

#### Audience

This course is designed for process & process control engineers responsible for configuring and maintaining Mimic simulation software.

### Mimic Fluid Modeling - Advanced – 7602 CEUs – 1.4

#### Overview

This 2-day course will build on foundations taught in Dynamic Simulation with Mimic while focusing on developing high fidelity models. Mimic's Advanced Modeling Objects will be used to create end-to-end, unified pressure driven flow networks while incorporating complete mass and energy balances across the entire model. The student will learn to create high fidelity models of processes that contain both liquid and vapor in numerous unit operations. Through lectures, demonstrations, and workshops, students will learn to construct a first principles and unit operations based model.

#### Topics

- Advanced modeling object configuration
- Model layout and flow network development
- Standard and advanced model aggregation
- Tuning and optimization

#### Audience

This course is for process and process control engineers responsible for configuring and maintaining high fidelity models of processes that contain both liquid and vapor in numerous unit operations.

#### Prerequisites

Dynamic Simulation with Mimic - 7601

### Mimic Fluid Modeling - Advanced – 7602 CEUs – 1.4



#### Overview

This 2-day course will build on foundations taught in Dynamic Simulation with Mimic while focusing on developing high fidelity models. Mimic's Advanced Modeling Objects will be used to create end-to-end, unified pressure driven flow networks while incorporating complete mass and energy balances across the entire model. The student will learn to create high fidelity models of processes that contain both liquid and vapor in numerous unit operations. Through lectures, demonstrations, and workshops, students will learn to construct a first principles and unit operations based model.

#### Topics

- Advanced modeling object configuration
- Model layout and flow network development
- Standard and advanced model aggregation
- Tuning and optimization

#### Audience

This course is for process and process control engineers responsible for configuring and maintaining high fidelity models of processes that contain both liquid and vapor in numerous unit operations.

#### Prerequisites

Dynamic Simulation with Mimic - 7601

### Mimic Solids Handling - Advanced – 7603 CEUs – 1.4

#### Overview

This 2-day course will build on foundations taught in Dynamic Simulation with Mimic and Advanced Fluid Modeling with Mimic in constructing high fidelity models with liquids, vapors, and solids. Mimic's Mining Advanced Modeling Objects will be introduced and used to incorporate material balances and particle size tracking across the entire model. The student will learn to create high fidelity models of processes that contain solids and slurries in a variety of different comminution and separation unit operations.

#### Topics

- Introduction to the advanced mining modeling package
- Configuration and layout of a plant model
- Tuning and optimization of slurry and solid streams
- Supporting standard modeling for improved process responses

#### Audience

This course is for process and process control engineers responsible for configuring and maintaining a Mimic simulation model with solids handling.

#### Prerequisites

None

### DeltaV - Industrial Ethernet with VIM2 – 7610 CEUs – 2.1

#### Overview

In this VIM2 Hardware and Software training course, students explore basic setup and configuration of VIM2 hardware and software. The course begins with an introduction to the VIM and firmware options, moving through setup, tuning and configuring the various drivers. Completion of this class will enable the student to better use their VIM2 and successfully integrate it with DeltaV.

#### Topics

- Introduction to the VIM and firmware options
- VIMNet Explorer and DeltaV Explorer Setup
- VIM Tuning
- Diagnostics
- Configurations of the different drivers
- Integration Best Practices

#### Audience

This course is for process and process control engineers responsible for configuring the VIM2 card.

## Operational Certainty Operator Displays – Advanced - 7625

### CEUs – 1.4

#### Overview

A properly implemented human machine interface (HMI) can reduce operator work load, improve situational awareness, and aid the operator in preventing minor deviations from becoming major incidents. The combination of HMI philosophy and style guides provides a rational and structured basis for ensuring all areas of importance relating to the human machine interface are successfully addressed. During the two-day course, capture best practice philosophy and standards for use in the design and development of the operator interface for your DCS.

#### Topics

- HMI Lifecycle
- System Standards Development (New System Entry Point)
- Philosophy
- Style Guide
- HMI Toolkit
- Design (Existing System with New Displays or Display Changes Entry Point)
- User, Task, and Functional Requirements
- Console Design
- HMI System Design
- Display Design
- Implement
- Operate
- Design
- Users - Definitions according to ISA 101.01
- Tasks (Things to Consider)
- Normal Operating Conditions
- Known Abnormal Operating Conditions
- Routine Operating Adjustments
- Functional Requirements
- Console Design
- HMI System Design
- Control System
- Third Party Interfaces
- Display Design
- Goals of HMI Design According to ISA 101.01
- Types of Displays
- Levels of Display
- Level 1 – Functional Overview
- Level 2 – Schematic Overview
- Level 3 – Detailed Process
- Level 4 – Other
- Navigation
- Execution Method for an Advanced HMI Project

**Audience:** This course is ideal for operators and process or controls engineers involved in the Human Machine Interface.

## Operational Certainty AgileOps Alarm Management Software - 7621

### CEUs – 2.1

#### Overview

During the 3-day course, become an expert on eliminating alarm floods for your site and meeting ISA 18.2 KPI performance metrics. Dynamic alarm management can increase productivity, reduce downtime, and improve safety. This course is specifically designed to help you realize these benefits through the optimal dynamic management of your control system with AgileOps software.

This course includes hands-on workstations with access to a live AgileOps system, allowing the student to fully understand the ease of use of AgileOps.

#### Topics

- Alarm Management and Philosophy
- Master Control System Database
- Branch Management
- Auto Discovery
- Alarm Templates
- Dynamic Management
- Creating Workspaces
- List Management
- Exclusion Lists
- Operator Helper
- EventKPI Reporting
- Configuration
- User Security
- Area Mapping
- KPI Targets
- Troubleshooting

#### Audience

This course is ideal for managers and engineers in plant operations, process, process controls, and safety and reliability.

#### Prerequisites

None.

## Operational Certainty Alarm Management - 7620

### CEUs – 1.4

#### Overview

Dynamic Alarm Management and the rationalization of alarms based on process state or mode is rapidly becoming recognized as the key solution path to eliminating alarm floods. Reducing alarm floods is vital to meeting the standards (ISA18.2, ISO/IEC 62682 and EEMUA 191) adopted by governing bodies (OSHA & IEC) and industry (AIChE). In addition, automated alarm shelving management has proven as another best practice for near elimination of long standing alarm lists on the operator's console.

Our process engineers will share the experiences and best practices learned through rationalizing and implementing Dynamic Alarm Management on hundreds of operator workstations worldwide. The results captured by this work has made significant impact on the safety and operational awareness of every operator and is still paying dividends to the operating companies who have embraced the application of sound process engineering principles.

#### Topics

Introduction to Alarm Management  
The Alarm Management Lifecycle  
Alarm Philosophy  
Identification, Rationalization and Detailed Design  
Management of Change, Implementation, Operation and Maintenance  
Monitoring and Assessment and Audit  
Dynamic Management and Alarm Shelving Concepts  
Project Execution Phases and Example Discussions

#### Audience

This course is ideal for managers and engineers in plant operations, process, process controls, and safety and reliability.

#### Prerequisites

None.

### Operational Certainty Planning Principles – Advanced - REL005 CEUs - 2.8

#### Overview

This intensive, 4-day hands-on course is designed to simulate real-world situations and teach participants how to effectively execute the planning function.

#### Topics

- Work Order Approval
- Job Scoping
- Job Plan Development
  - Developing Procedures and Instruction
  - Performing Time Estimates
  - Material Requirements
  - Identifying Reference Material
  - Developing Post-Maintenance Checks and Completion Testing Requirements
- Utilizing Craft Comments and Incorporating Feedback
- Explain Backlog and Compile Backlog Trend and Reports

### Operational Certainty Developing Reliability-Based Maintenance Strategies – Introduction – REL003 CEUs - 1.4

#### Overview

This 2-day course is an introduction to the basic maintenance strategy model that will act as the foundation of developing RCM techniques, choosing and deploying PMs and creating an effective maintenance strategy to support an efficient maintenance environment.

#### Topics

- Maintenance Strategy Models
- Basic RCM Techniques
- PM Task Selection
- Basic PM Tools
- PM Program Design
- PM Development Principles
- PM Scheduling Techniques
- PM Program Monitoring

### Operational Certainty Planning & Scheduling Principles – Introduction - REL004 CEUs - 1.4

#### Overview

This introductory 2-day course is designed to provide participants with an understanding of the fundamentals of creating and maintaining an efficient planning and scheduling program.

#### Topics

- Planning and Scheduling World Class Model
  - Advantages of the Planning Process
  - Characteristics of the Planning and Scheduling World Class Model
  - Characteristics of Planning and Scheduling World Class Model
  - Ratios of Planner, Scheduler and Supervisor to Craftsmen
  - Use and benefit of Predictive Maintenance Technologies
  - Material management impact on Planning and Scheduling
- Planning Principles
  - Planning Fundamentals
  - Basic Job Plan Requirements
  - Requirements of Basic Job Plan Writing
  - Importance of Quantitative Preventative Maintenance Tasks
  - Basic Job Plan Writing and Estimating
  - Work Requests versus Work Orders
- Scheduling Principles
  - Criteria of Scheduling Priorities
  - Criteria for PM Schedule Development
  - Scheduling Fundamentals
  - Relationship Between Resource Availability and Resource Allocation
- Planning and Scheduling Program Monitoring
- Successful Implementation of the Planning and Scheduling Model
- Quality Program Performance Measures
- Selection and Utilization of an Integrated
- CMMS System

### Operational Certainty Foundational Awareness - REL009 CEUs – 2.8

#### Overview

This comprehensive 4-day course is designed to provide participants with an understanding and appreciation of the many foundational elements required for success in the maintenance and reliability field. Both technical and non-technical areas must be understood and integrated in order to be most effective in the maintenance and reliability profession.

#### Topics

- Business and Management:
  - Strategic Direction and Plan
  - Selling Programs and Change to Stakeholder
  - Create Measurement and Performance Evaluation System
  - Business Case Preparation
  - Communicate to Stakeholders
  - Plan and Budget Resources
  - Maintenance/ Operations Performance Agreements/Specifications
- Manufacturing Process Reliability:
  - Maintain Process and Industry Standards and Specifications
  - Understand the Manufacturing Process
  - Manufacturing Effectiveness Techniques
  - Safety, Health, Environmental Issues
  - Manage Effects of Changes to Processes and Equipment
- Equipment Reliability:
  - Determine Equipment and Process Performance Expectations from the Business Plan
  - Establish Current Performance Levels and Analyze Gaps
  - Establish a Maintenance Strategy to Assure Performance
  - Cost-Justify (Budget) Tactics Selected for Implementation
  - Execute a Maintenance Strategy
  - Review Performance and Adjust Maintenance Strategy
- People Skills:
  - How to Assess Organizational Competence and Direction
  - How to Develop the Maintenance and Reliability Organization Structure and Staff
  - How to Communicate Maintenance and Reliability to the Organization



### Operational Certainty Awareness - REL009 – Continued...

- Work Management:
  - Comprehensive Work Identification
  - Plant-Wide Formal Prioritization System; Effective Work Planning Prior to Scheduling
  - Cooperative Work Scheduling and Backlog Management
  - Effective Resource Management (People, Materials, Financial)
  - Document Work Execution and Update of Records/History
  - Equipment History Review and Failure Identification
  - Effective Performance Measures and Follow-up
  - Capital Project Planning Requirements
  - Effective Use of Information Technologies (CMMS, etc)

### Operational Certainty The Reliability Game - REL001

#### Overview

The Reliability Game focuses on participants' attention on the maintenance function at a facility. This 1-day game is a simulation that clearly demonstrates the value of proactive reliability practices and the positive effects it has on the bottom line. The simulation is both fun and educational. The simulation also provides a mechanism to help the participants create a common understanding of basic reliability business goals.

#### Topics

- The Financial Opportunity Associated with Proactive Maintenance
- Where the Money Goes
- How to Stop Wasting Money
- The Value of Proactive Maintenance to Their Maintenance Processes
- The Power of Teamwork
- The Logic Behind Emerson Benchmark Data
- Concept of the Failure Interval on the Potential Failure Curve (P-F Interval) and its Relationship to the Planning Process
- Proactive Maintenance Model

### Operational Certainty Maintenance 101/201 - REL008 CEUs - .7

#### Overview

It is well documented that managing the maintenance function in a proactive rather than a reactive manner results in lower costs and superior asset performance. This is easy to say but difficult to do in actual practice. This 1-day course will explore twenty of the most basic fundamentals that every Maintenance Manager must have in place in order to make a proactive maintenance organization a reality.

#### Topics

- Introduction
- Elements of a Proactive Maintenance Philosophy
- Equipment Failures Are Unacceptable
- Important Work vs. Urgent Work
- The Maintenance-Operations Partnership
- The Importance of Good Data
- Entropy as It Applies to Maintenance
- Precision Maintenance - The Last Frontier
- The System Wins Every Time
- Effective Methods for Reducing Maintenance Costs
- Processes that Must Be in Place
- Build a Solid Foundation First
- The Work Management System
- Planning
- Scheduling
- Storeroom Inventory Management
- The Importance of Predictive Maintenance
- Organizational Structure Considerations
- Why Reliability Engineers Are Critical
- The Importance of Field Supervision
- The Importance of Procedures

### Operational Certainty Materials Management Strategies - REL006 CEUs - 1.4

#### Overview

This introductory 2-day course is designed to provide participants instruction about how to manage, organize, and control inventory risk through strategic MRO inventory management.

#### Topics

- Introduction
- Maintenance Storeroom Purpose
- Maintenance Storeroom Functions and Expectations
- Meeting Expectations
- Purpose and Strategic Importance
- Role of Stores
- Best Practices to Achieve Effective Stores Management and Implement Reliability
- Organizing for Maintenance Stores and Management Control
- Inventory Management Key Elements
- Inventory Record Accuracy (IRA)
- Storeroom Access and Control
- Inventory Catalog
- Stores Management Tools
- Stores/Inventory Cost
- Obsolete Parts and Location
- Stores Control Methods
- The Replenishment Process
- Inventory Record Accuracy (IRA) Benefits
- High Performance Stores
- Storeroom Best Practice Guidelines
- Quality Control
- Stores KPI Metrics and World Class Benchmarks

**Operational Certainty Predictive Maintenance Technology Awareness - REL011**  
CEUs – 1.6

**Overview**

Predictive Maintenance Technology Awareness

This seminar increases personnel awareness of the need for a "precision" approach through use of extensive case histories and success stories. It explores the effective implementation of Machinery Reliability Programs; provides an overview of the current PdM technologies and their appropriate applications; and provides information on proven methods for justifying the investment in PdM tools, time, and training.

**Topics/COURSE OUTLINE:**

- Unit 1 Introduction
- Unit 2 Machinery Reliability Overview
- Unit 3 Introduction to Vibration Detection and Analysis
- Unit 4 Introduction to Ultrasonics
- Unit 5 Introduction to Infrared Thermography
- Unit 6 Introduction to Oil Analysis
- Unit 7 Application of Condition Monitoring Technologies to Common Problems
- Unit 8 Work Performance, Job Plan Improvement and Equipment Reliability Improvement Processes

**Audience**

Management, Reliability Staff, Maintenance Staff

**Prerequisites**

None

**Operational Certainty Reliability Awareness Featuring the Reliability Game - REL002**

**Overview**

This 2-day combination of The Reliability Game and expanded topics around the development of a Reliability Based Maintenance Program. The Reliability Game focuses participants' attention on the maintenance function at a facility. The game is a simulation that clearly demonstrates the value of proactive reliability practices and the positive effects it has on the bottom line. The simulation is both fun and educational. The simulation also provides a mechanism to help the participants create common understanding of basic reliability business goals.

The Reliability Overview discusses the essential elements learned through playing the Reliability Game and reinforces how a strong reliability program helps corporations achieve success.

**Topics**

- The Financial Opportunity Associated with Proactive Maintenance
- Where the Money Goes
- How to Stop Wasting Money
- The Value of Proactive Maintenance to Their Maintenance Processes
- The Power of Teamwork
- The Logic Behind Emerson Benchmark Data
- Concept of the Failure Interval on the Potential Failure Curve (P-F Interval) and its Relationship to the Planning Process
- Proactive Maintenance Model
- Financial Benefit of Advanced Planning of Maintenance Work
- Typical Preventative Maintenance (PM) Programs seen in Industry Today
- Criticality Ranking Process
- Nature of Failures
- Process for Conducting a Reliability Centered Maintenance (RCM) and a Failure Modes and Effects Analysis (FMEA)
- Importance of PM and Predictive Maintenance
- (PDM) Development, Including the concept of Quantitative PMs
- The Key Concepts of Change Management

**Operational Certainty Reliability Centered Maintenance Principles - REL007**  
CEUs – 1.4

**Overview**

Reliability Centered Maintenance Analysis (RCM) is a key foundational element of a Reliability Based Maintenance program.

This 2-day course covers all important aspects of Reliability Centered Maintenance Analysis and Implementation. Participants will learn how to effectively participate in an RCM program and have all necessary information to support such an implementation.

**Topics**

- Introduction
  - History of RCM
  - Why RCM
  - Selecting Candidate Equipment
  - Team Approach
  - RCM Philosophies
- Conducting RCM Analysis
  - RCM Terms and Definitions
  - Identifying System Parameters
  - Answering the 7 Questions of RCM
  - Determining Failure Mitigation Strategies
  - Implementing the Results of RCM Analysis
  - Facilitating RCM at Your Site
  - Who should Lead
  - Choosing the Appropriate Analysis Tools
  - Tracking Progress through to Completion
  - Avoiding the Causes of Failed RCM
  - Implementations
  - Leveraging the Benefits of RCM
  - Lateral Deployments
  - The FMEA Library
  - Celebrating Results
  - Showing the Business Case

### Ovation AMS Suite Intelligent Device Manager - OV275

#### Overview

The OV275 - Virtual course is designed to enable the end-user to configure and use the Emerson's AMS Suite: Intelligent Device Manager with the Ovation™ control system. Students will receive hands-on experience using the Ovation and AMS Device Manager to configure Smart Devices on the Ovation network. Students will also configure and examine Ovation PlantWeb Alerts generated from the Smart Devices. This course will provide instruction on how to configure and troubleshoot the Ovation system and AMS Device Manager

#### Topics

Upon successful completion of this course, using the reference material provided, the student will be able to:

- Understand the basic topology of an Ovation network that includes an AMS Intelligent Device Manager Station
- Recognize AMS Suite software applications
- Understand AMS Intelligent Device Manager licensing
- Complete normal AMS Intelligent Device Manager administrative functions
- Use basic AMS Intelligent Device Manager functions
- Understand AMS Intelligent Device Manager SNAP-ON capabilities
- Update AMS Intelligent Device Manager DD files

#### Prerequisites

Ovation – Data Acquisition – OV100 and Ovation – HART and Smart Devices – OV270

### Ovation AMS Suite Intelligent Device Manager – Virtual - OV275V



#### Overview

The OV275 - Virtual course is designed to enable the end-user to configure and use the Emerson's AMS Suite: Intelligent Device Manager with the Ovation™ control system. Students will receive hands-on experience using the Ovation and AMS Device Manager to configure Smart Devices on the Ovation network. Students will also configure and examine Ovation PlantWeb Alerts generated from the Smart Devices. This course will provide instruction on how to configure and troubleshoot the Ovation system and AMS Device Manager

#### Topics

Upon successful completion of this course, using the reference material provided, the student will be able to:

- Understand the basic topology of an Ovation network that includes an AMS Intelligent Device Manager Station
- Recognize AMS Suite software applications
- Understand AMS Intelligent Device Manager licensing
- Complete normal AMS Intelligent Device Manager administrative functions
- Use basic AMS Intelligent Device Manager functions
- Understand AMS Intelligent Device Manager SNAP-ON capabilities
- Update AMS Intelligent Device Manager DD files

#### Prerequisites

Ovation – Data Acquisition – OV100 and Ovation – HART and Smart Devices – OV270

### Ovation Applications with DeviceNet - OV345

#### Overview

The OV345 is designed to provide the end-user with a thorough knowledge of DeviceNet applications as applied to an Ovation™ system. Taught subjects include: Ovation DeviceNet Module, segment design, device commissioning, point mapping and basic troubleshooting. Students will be provided with hands-on experience implementing DeviceNet architecture.

#### Topics

Upon successful completion of this course, using the reference material provided, the student will be able to:

- Define Ovation DeviceNet architecture
- Understand DeviceNet operation and communication
- Implement an Ovation specific DeviceNet scheme and topology
- Build Ovation points for use in DeviceNet architecture
- Implement control loops in fieldbus and feedback to Ovation
- Configure Ovation graphics to function with a fieldbus system
- Analyze the timing of the system when fully operational

#### Prerequisites

OV100 - Starting with Data Acquisition and OV200 - Building and Maintaining Ovation Control. OV275 - AMS Suite: Intelligent Device Manager - is recommended but not required.

### Ovation Applications with Profibus - OV350

#### Overview

The OV350 course is designed to provide the end-user with a thorough knowledge of Profibus applications as applied to the Ovation™ system. Topics for discussion include: Ovation Profibus Module, segment design, device commissioning, point mapping and basic troubleshooting. Students will gain hands-on experience implementing Profibus architecture.

#### Topics

Upon successful completion of this course, using the reference material provided, and the student will be able to:

- Define Ovation Profibus architecture
- Understand Profibus operation and communications
- Identify the required hardware and software needed for an Ovation Profibus interface
- Update the Ovation/Sycon Device list
- Demonstrate the Sycon engineering tool to configure Profibus devices
- Build Ovation points for use in Profibus architecture
- Implement an Ovation specific Profibus scheme and topology

#### Prerequisites

Ovation – Data Acquisition -OV100

### Ovation AV Management - OV367

#### Overview

The OV367 course is designed for the end-user charged with maintaining the anti-virus solutions for the Ovation™ System. Course will focus on installing endpoint software, obtaining and distributing virus definitions, upgrading anti-virus versions and configuring the AV servers.

#### Topics

Upon successful completion of this course, using the reference material provided, the student will be able to:

- Configure the anti-virus server
- Run reports
- Update virus definitions
- Install anti-virus software on endpoints

### Ovation AV Management – Virtual - OV367V



#### Overview

The OV367V course is designed for the end-user charged with maintaining the anti-virus solutions for the Ovation™ System. Course will focus on installing endpoint software, obtaining and distributing virus definitions, upgrading anti-virus versions and configuring the AV servers.

#### Topics

Upon successful completion of this course, using the reference material provided, the student will be able to:

- Configure the anti-virus server
- Run reports
- Update virus definitions
- Install anti-virus software on endpoints

### Ovation Base Certification - OV400

#### Overview

The OV400 course is offered to the end-user as a stand-alone or web-based exam or implemented with a pre-testing review at the Training Center. The student's proficiency is measured in areas related to database building, control implementation, control graphic linkage and troubleshooting on a system-wide basis. For both offerings, a multi-point examination is administered, and participants are required to achieve a grade score >80% to successful gain certification.

#### Topics

Upon completion of this course and achieving a successful level of competency in the online examination, the student will receive an Ovation™ certification award. This achievement affirms and recognizes that the student is fully cognizant and possesses the necessary skills to successfully engineer and maintain an Ovation control system for their organization. The student has demonstrated proficiency in the following areas:

- Building saving and implementing the Oracle database
- Constructing control sheets using both Boolean and Analog logic
- Loading and configuring the Ovation™ Controller
- Designing graphics with control implementation
- Troubleshooting procedures as related to I/O and Controller modules

#### Prerequisites

Ovation – Data Acquisition – OV100,  
Ovation – Building and Maintaining Ovation Control – OV200, Ovation - Building Ovation Graphics – OV210 and Ovation Troubleshooting - OV300

### Ovation Base Certification – Virtual - OV400V



#### Overview

The OV400 course is offered to the end-user as a stand-alone or web-based exam or implemented with a pre-testing review at the Training Center. The student's proficiency is measured in areas related to database building, control implementation, control graphic linkage and troubleshooting on a system-wide basis. For both offerings, a multi-point examination is administered, and participants are required to achieve a grade score >80% to successfully gain certification.

#### Topics

Upon completion of this course and achieving a successful level of competency in the online examination, the student will receive an Ovation™ certification award. This achievement affirms and recognizes that the student is fully cognizant and possesses the necessary skills to successfully engineer and maintain an Ovation control system for their organization. The student has demonstrated proficiency in the following areas:

- Building saving and implementing the Oracle database
- Constructing control sheets using both Boolean and Analog logic
- Loading and configuring the Ovation™ Controller
- Designing graphics with control implementation
- Troubleshooting procedures as related to I/O and Controller modules

#### Prerequisites

Ovation – Data Acquisition – OV100, Ovation – Building and Maintaining Ovation Control – OV200, Ovation - Building Ovation Graphics – OV210 and Ovation Troubleshooting - OV300

### Ovation Best Practices - OV301

#### Overview

The OV301 course is designed to provide the end-user with the knowledge and methods to maintain a reliable Ovation™ DCS working system with regard to: Ovation database, OPH configuration techniques, network monitoring, control task monitoring, best graphics practices, I/O reliability, patching, backups, Anti-Virus and engineering gathered utilities.

#### Topics

Upon successful completion of this course, using the reference material provided, the student will be able to:

- Perform backups on the Ovation system
- Install anti-virus programs on the Ovation system
- Monitor the overall reliability of the Ovation system
- Install software patches on the Ovation System

#### Prerequisites

Ovation - Data Acquisition - OV100, Ovation – Building and Maintaining Ovation Control – OV200 and Ovation – Building Ovation Graphics – OV210

### Ovation Best Practices – Virtual - OV301V



#### Overview

The OV301 course is designed to provide the end-user with the knowledge and methods to maintain a reliable Ovation™ DCS working system with regard to: Ovation database, OPH configuration techniques, network monitoring, control task monitoring, best graphics practices, I/O reliability, patching, backups, Anti-Virus and engineering gathered utilities.

#### Topics

Upon successful completion of this course, using the reference material provided, the student will be able to:

- Perform backups on the Ovation system
- Install anti-virus programs on the Ovation system
- Monitor the overall reliability of the Ovation system
- Install software patches on the Ovation System

#### Prerequisites

Ovation - Data Acquisition - OV100, Ovation – Building and Maintaining Ovation Control – OV200 and Ovation – Building Ovation Graphics – OV210

### Ovation Boiler Control - OV380

#### Overview

The OV380 course is an introduction to boiler control for those who interface with control programs or may make modifications to their existing control programs. Using previous control-building knowledge, the student will learn how to implement and design pertinent boiler control logic in an Ovation™ environment. Instruction will emphasize the proper selection, configuration and application of algorithms in a typical Ovation boiler control system. The writing of control logic is included as course work.

#### Topics

Upon successful completion of this course, using the reference material provided, the student will be able to:

- Review the history of boilers
- Review the development of boiler safety and the development of standards
- Discuss the typical control logic used in the water, steam, air and fuel systems
- Discuss and review SAMA and ISA control symbols
- Discuss and review measuring elements and final control elements used in boiler control
- Discuss and review compensations, conversions and voting in measuring elements
- Discuss and review three element drum control, cross limiting control, de-superheat control, furnace pressure control, fuel calculations and O2 correction
- Discuss and review stoichiometric relationships in boiler control
- Discuss the typical types of control utilized in boilers: ratio, feed forward, cascade, single element, two element, and three element
- Discuss and review the different components of a boiler: reheat, wall burners, tangentially fired burners, ID and FD fans, mills and feed pumps

#### Prerequisites

Ovation - Data Acquisition - OV100, Ovation – Building and Maintaining Ovation Control – OV200



### Ovation Building & Maintaining Ovation Control - OV200

#### Overview

The OV200 course is designed to provide proficiency in reading Ovation™ functional control schemes. Tuning, building and implementing new control schemes to improve performance are covered. Both modulating (analog) and discrete digital control schemes are included in the scope of the course. Discussions include the various types of control algorithms available and how they can be used to create effective control. The course is further intended for people who work with Ovation Controllers to tune and build analog and digital control schemes in a Windows environment.

#### Topics

Upon successful completion of this course and using the reference materials provided, the student will be able to:

- Interpret and apply a control functional to the Ovation Windows-based system.
- Interpret and tune implemented control using the available tools.
- Edit existing control schemes
- Demonstrate proficiency in building digital and analog control.
- Design and implement a tracking scheme to meet specific control requirements.
- Recognize the relationship between control schemes and graphic diagrams.
- Implement given control requirements using the Control Builder.
- Evaluate and determine the proper operation of a control scheme using the tools and methods provided.

#### Prerequisites

Students must have a good understanding of the Ovation system architecture and how database point records are built and maintained in the Ovation Windows-based system. Student should attend the OV100 prior to attending this course.

### Ovation Building Ovation Graphics – OV210

#### Overview

The OV210 course was designed to teach the end-user how to construct graphic diagrams that depict the controlled process. Students will use the Ovation™ Graphics Builder program to build process diagrams, implement the display of static and dynamic objects, and provide for control linkage and conditional changes that occur due to alarm conditions or process changes. Methods for standardizing information entities, control interfaces and troubleshooting problems within the graphics code are also covered.

#### Topics

Upon successful completion of this course, using the reference material provided, the student will be able to:

- Describe the different building areas within the graphic source code
- Build graphics to display static and dynamic plant data
- Employ various drawing techniques to create 3D graphics
- Directly link graphics to actual control using poke fields
- Design and implement MACROS used within graphics
- Implement conditional statements to create dynamic indications within the graphic
- Employ various techniques that enable the graphic code to execute more efficiently
- Use various application programs within a graphic to perform a specific function
- Assess and correct problems in graphics using available tools

#### Prerequisites

OV100 and OV200 are strongly recommended

### Ovation Building Ovation Graphics – Virtual - OV210V



#### Overview

The OV210 course was designed to teach the end-user how to construct graphic diagrams that depict the controlled process. Students will use the Ovation™ Graphics Builder program to build process diagrams, implement the display of static and dynamic objects, and provide for control linkage and conditional changes that occur due to alarm conditions or process changes. Methods for standardizing information entities, control interfaces and troubleshooting problems within the graphics code are also covered.

#### Topics

Upon successful completion of this course, using the reference material provided, the student will be able to:

- Describe the different building areas within the graphic source code
- Build graphics to display static and dynamic plant data
- Employ various drawing techniques to create 3D graphics
- Directly link graphics to actual control using poke fields
- Design and implement MACROS used within graphics
- Implement conditional statements to create dynamic indications within the graphic
- Employ various techniques that enable the graphic code to execute more efficiently
- Use various application programs within a graphic to perform a specific function
- Assess and correct problems in graphics using available tools

#### Prerequisites

OV100 and OV200 are strongly recommended

### Ovation Control Techniques - Advanced - OV330

#### Overview

The OV330 - Virtual offered course is designed for end-users who will implement their own control programs or who will make significant modifications to existing programs. Using previous control-building knowledge, the student will learn how to implement control design in an Ovation™ environment. The course will emphasize the proper selection, configuration and application of algorithms in the Ovation control system.

#### Topics

Upon successful completion of this course, using the reference material provided, the student will be able to:

- Apply, tune and track all appropriate algorithms in open-and-closed loop configurations
- Select, filter and compensate transmitter inputs
- Implement complex sequential control
- Appreciate important closed-loop control forms
- Configure general math computations
- Describe the interface of selected algorithms to I/O hardware
- Use algorithms for timing, counting, accumulation and system-time applications

#### Prerequisites

Ovation - Building and Maintaining Ovation Control – OV200

### Ovation Control Techniques - Advanced – Virtual - OV330V



#### Overview

The OV330 - Virtual offered course is designed for end-users who will implement their own control programs or who will make significant modifications to existing programs. Using previous control-building knowledge, the student will learn how to implement control design in an Ovation™ environment. The course will emphasize the proper selection, configuration and application of algorithms in the Ovation control system.

#### Topics

Upon successful completion of this course, using the reference material provided, the student will be able to:

- Apply, tune and track all appropriate algorithms in open-and-closed loop configurations
- Select, filter and compensate transmitter inputs
- Implement complex sequential control
- Appreciate important closed-loop control forms
- Configure general math computations
- Describe the interface of selected algorithms to I/O hardware
- Use algorithms for timing, counting, accumulation and system-time applications

#### Prerequisites

Ovation - Building and Maintaining Ovation Control – OV200

### Ovation Database/Troubleshooting - Advanced - OV302

#### Overview

This course is designed for engineers and technicians that have used Ovation Developer Studio on a consistent basis. Troubleshooting is a primary role for technicians and engineers. Topics covered include controller failures, networking, algorithm troubleshooting, Ovation services, NTP problems, HART, 3rd party and remote I/O issues.

#### Topics

1. Review Ovation tools for troubleshooting
2. Identify and solve advanced troubleshooting problems

### Ovation - Database/Troubleshooting - Advanced – Virtual - OV302V



#### Overview

This course is designed for engineers and technicians that have used Ovation Developer Studio on a consistent basis. Troubleshooting is a primary role for technicians and engineers. Topics covered include controller failures, networking, algorithm troubleshooting, Ovation services, NTP problems, HART, 3rd party and remote I/O issues.

#### Topics

1. Review Ovation tools for troubleshooting
2. Identify and solve advanced troubleshooting problems

## Ovation Data Acquisition - OV100

### Overview

For those new to the Ovation™ system, the Ovation Data Acquisition course covers Ovation terminology, Operator functions and the Ovation Controller physical layout. The course offers practice using the Ovation engineering tools that are designed to simplify data acquisition. Data acquisition types include digital, analog and analog temperature sensing sources, as well as introducing the end-user to the Developer Studio for point building and I/O module configuration.

### Topics

- Identify the major components in an Ovation™ system
- Understand basic Ovation terminologies
- Identify the major devices and subsets in an Ovation Controller Cabinet
- Demonstrate basic Ovation operator functions
- Understand data movement in an Ovation system
- Utilize the Ovation Developer Studio to create and modify digital and analog process points
- Configure I/O modules for temperature data acquisition
- Address, hardwire and test I/O modules

## Ovation Digital Generator Control - OV376

### Overview

The OV376 is designed for the end-user that will interface and maintain the DGC system. The course provides the history and fundamentals of generator excitation with an overview of the excitation types and concepts of SCR bridges. Course topics include the DGC and its elemental components, maintenance and troubleshooting, data retrieval and analysis.

### Topics

Upon successful completion of this course, using the reference material provided, the student will be able to:

- Navigate the control software and review alarm
- Understand basic DGC troubleshooting and maintenance procedures
- View the DGC Application Software Display, Log-view and Sequence of Events
- Understand basics of Amplifiers, Firing Circuits and the Controller
- Review the fundamentals and technology associated with the DGC

## Ovation EDS Enterprise Data Server - OV248

### Overview

This (virtual) course is designed to give students a detailed understanding of the EDS™. Upon completion of this course, the student will be able to configure an EDS server to collect point data from an existing Ovation™ system. An EDS client will be properly configured and the applications of the EDS station will be covered extensively. This course is designed for anyone who will be using or managing the EDS.

### Topics

Upon successful completion of this course, using the reference material provided, the student will be able to:

- Illustrate the functions of the EDS system and architecture
- Explain how an EDS server is loaded and configured
- Configure and EDS client to communicate with an existing EDS
- Manage the data storage of the EDS
- Demonstrate how to view and interpret error messages
- Build reports using the EDS Report Builder

## Ovation Evergreen Upgrade - OV115

### Overview

This course is designed to teach the Ovation™ Windows software utility packages from a higher level. The course provides instruction on the Ovation Windows studio of application programs including the building of point records, control sheets, graphic displays and the loading, saving and downloading of each entity. Topics for discussion include: basic networking, Ovation architecture and components, Operator functions, Developer Studio features, control and graphics building and basic system configuration.

### Topics

Upon successful completion of this course and using the reference material provided, the student will be able to:

- Describe the functions and differences of the Ovation Windows network and its components.
- Monitor plant processes using Ovation Windows data acquisition tools.
- Navigate and understand the Ovation Developer Studio.
- Demonstrate a basic level of proficiency using the Ovation Control Builder.
- Demonstrate a basic level of proficiency using the Ovation Graphics Builder.
- Understand and implement some basic Ovation Windows configuration changes.

## Ovation OPH Report Building - OV246

### Overview

The OV246 - Virtual offered course was designed to teach the end-user how to configure and retrieve historical data using the Ovation™ Process historian (OPH) and Crystal Reports. Students will use the OPH Report Manager to define (Alarm, SOE, and Operator Event) reports. Using the same manager, students will learn how to configure (On-Demand, Triggered and Timed) reports. Students will also use Crystal Reports to create new report formats for use in the OPH Report Manager.

### Topics

Upon successful completion of this course, using the reference material provided, the student will be able to:

- Describe the functions of the Ovation™ Process Historian and its related components
- Recognize the Ovation Process Historian Database Schema
- Understand the concept of a Relational Database Management System
- Schedule, automate and manipulate reports
- Distribute reports using printers and various output files
- Create custom reports using 3rd party applications such as Crystal Reports and MS Excel

### Prerequisites

Ovation - Data Acquisition – OV100

### Ovation EDS Enterprise Data Server – Virtual - OV248V



#### Overview

This (virtual) course is designed to give students a detailed understanding of the EDS™. Upon completion of this course, the student will be able to configure an EDS server to collect point data from an existing Ovation™ system. An EDS client will be properly configured and the applications of the EDS station will be covered extensively. This course is designed for anyone who will be using or managing the EDS.

#### Topics

Upon successful completion of this course, using the reference material provided, the student will be able to:

- Illustrate the functions of the EDS system and architecture
- Explain how an EDS server is loaded and configured
- Configure and EDS client to communicate with an existing EDS
- Manage the data storage of the EDS
- Demonstrate how to view and interpret error messages
- Build reports using the EDS Report Builder

### Ovation Enterprise Data Server Administration - Virtual - OV249V



#### Overview

This course is designed to give students a more in-depth understanding of the EDS server and feeders. Upon completion of the course, students will be able to configure an EDS server to collect point data from an existing Ovation system. An EDS client will be properly configured as well as an EDS feeder. The course is designed for anyone managing the EDS server & feeders. Report building from terminal and the Excel plug-in will also be incorporated into the 5-day training.

#### Topics

1. DESCRIBE the functions of the EDS and related components
2. RECOGNIZE the hardware used in an EDS
3. UNDERSTAND EDS server configuration and setup
4. LOAD and CONFIGURE Data Interfaces to Ovation
5. LOAD and CONFIGURE an EDS server
6. LOAD and CONFIGURE Database Access Software components
7. NAVIGATE and UNDERSTAND the Database Access application
8. LOAD and CONFIGURE EDS Terminal Software components
9. TROUBLESHOOT common EDS issues
10. MAINTAIN the EDS
11. DEFINE reports using the Report Editor application
12. BUILDING reports in Excel
13. MONITOR reports using the Report Monitor application
14. RECOGNIZE the function of the Messages application

### Ovation Ethernet Link Controller with Third Party I/O - OV296

#### Overview

The OV296 course was designed to enable the end-user to configure, network and troubleshoot Ethernet Link Controllers and third-party I/O points. Topics covered include: configuration of the ELC in Developer Studio, using the ELC Configuration Tool, simplex and redundant ELC's, networking, communication protocols, editing XML files, graphics, troubleshooting and building third-party I/O points. Students will configure the ELC to communicate with RTU's via both the Ethernet and Serial links.

#### Topics

Upon successful completion of this course, using the reference material provided, the student will be able to:

- Explain the workings of an ELC as well as its purpose
- Distinguish differences between switches and routers
- Explain how IP addresses and subnet masks work
- Differentiate between TCP and serial products
- Configure both simplex and redundant ELC's in Developer Studio
- 6. Install the ELC Configuration Tool and license the communication protocols
- Download firmware to the ELC module
- Utilize the ELC Configuration Tool to build servers, ports, lines, RTU's and scan-blocks
- Edit XML files to perform mass edits of the ELC
- Build graphics to monitor and troubleshoot the ELC
- Configure third-party I/O points
- Map Ovation™ points to third-party RTU's over various protocols

### Ovation Expert Transition - OV265

#### Overview

The OV265 course was designed to provide the end-user with proficiency in updating the Ovation™ interface after a change has been made to the Bailey I/O. Students will learn the basic mechanics of using the Ovation OPC client and OPC90 Server (ROVISYS) applications. Course elements include layout and implementation of the hardware and software required for the migration. Simple methods for troubleshooting faults will also be discussed.

#### Topics

Upon successful completion of this course, using the reference material provided, the student will be able to:

- Understand the different methods of a Bailey to Ovation™ migration
- Recognize hardware components used for the Bailey to Ovation migration
- Recognize software components used for the Bailey to Ovation migration
- Understand Bailey block to Ovation point mapping
- Use the Bailey to Ovation migration tool
- Update the Ovation interface when changes are made to the Bailey I/O
- Troubleshoot the Ovation interface using ROVISYS and OPC Client Mapper

#### Prerequisites

Ovation - Data Acquisition – OV100

### Ovation Expert Transition - OV265

#### Overview

The OV265 course was designed to provide the end-user with proficiency in updating the Ovation™ interface after a change has been made to the Bailey I/O. Students will learn the basic mechanics of using the Ovation OPC client and OPC90 Server (ROVISYS) applications. Course elements include layout and implementation of the hardware and software required for the migration. Simple methods for troubleshooting faults will also be discussed.

#### Topics

Upon successful completion of this course, using the reference material provided, the student will be able to:

- Understand the different methods of a Bailey to Ovation™ migration
- Recognize hardware components used for the Bailey to Ovation migration
- Recognize software components used for the Bailey to Ovation migration
- Understand Bailey block to Ovation point mapping
- Use the Bailey to Ovation migration tool

### OV265 – Continued...

- Update the Ovation interface when changes are made to the Bailey I/O
- Troubleshoot the Ovation interface using ROVISYS and OPC Client Mapper

#### Prerequisites

Ovation - Data Acquisition – OV100

### Ovation Graphics - Advanced - OV310

#### Overview

The OV310 course is designed to provide the end-user with enhanced graphic programming skills: Topics for discussion include: Macros, Pointers, special application programs, trigger statements, sub-routines and correct coding for increased graphic execution speed.

#### Topics

Upon successful completion of this course, using the reference material provided, the student will be able to:

- Define the different memory segments available in the graphic subsystem
- Build graphics utilizing pointer commands with segmented memory
- Interpret and use the library of application programs
- Use the trigger section of the graphics code for efficiency
- Use graphic commands only available in a text editor
- Troubleshoot graphics code using available tools

#### Prerequisites

Ovation - Data Acquisition – OV100

Ovation – Building & Maintaining Ovation

Control – OV200

Ovation – Building Ovation Graphics – OV210

### Ovation Graphics - Advanced – Virtual - OV310V

#### Overview

Uses application programs and advanced programming techniques, including the use of memory segments combined with pointer manipulation, to enhance advanced graphic programming skills. Builds several graphics utilizing pointers and memory segments. Teaches students to assess problematic graphics and solve them with available tools.

#### Topics

1. Define the different memory segments available in the graphics subsystem
2. Build several graphics utilizing pointers and memory segments
3. Interpret application programs
4. Use the trigger section of the graphics code for efficiency
5. Use graphic commands only available in a text editor
6. Troubleshoot graphics with available tools

### OV310V – Continued...

7. Define and implement different types of Variables
  8. Build Graphics Utilizing Variables
  9. Build Graphics using embedded macros
- Prerequisites**  
OV100, OV200, OV210

### Ovation Hardware Project - OV216

#### Overview

The OV216 course is designed for the end-user whose primary interest and/or assignment is maintaining Ovation™ hardware. Selected topics from several courses are incorporated and expanded upon. Topics included are the replacement and set-up of an Ovation Controller and Flask Disk. Several different power supply configurations are discussed. Attendees will install new I/O Thermocouple/RTD modules and build several temperature-derived points. Students will install a HART® (4-20) ma analog input module and transmitter. Each student will install and configure an Ovation Remote Node Controller with fiber connections.

#### Topics

Upon successful completion of this course, using the reference material provided, the student will be able to:

- Utilize documentation to analyze faults or problem conditions in the Ovation™ System
- Interpret Ovation system error messages
- Demonstrate remote I/O technology
- Understand recovery or hard-drive failures on MMI's
- Configure CISCO switches and routers
- Monitor status LED's of the Ovation system
- Build various RM records
- Implement closed loop control strategies
- Evaluate and determine operation of power supplies

#### Prerequisites

Ovation - Data Acquisition – OV100

, Ovation - Building and Maintaining Ovation Control – OV200 and Ovation – Software Project – OV215



**Ovation HART & Smart Devices - OV270****Overview**

The OV270 - Virtual offered course was designed to provide the end-user with the skills to fully utilize the special features of I/O related to HART® and Smart Field Devices attached to the Ovation™ system. Students will learn the basic components of an Ovation system. Items discussed will include physical attachment of field devices to the Ovation I/O modules, and diagnosis of problems that may occur.

**Topics**

Upon successful completion of this course, using the reference material provided, the student will be able to:

- Identify the configuration of components in an Ovation™ system using HART/Smart Devices
- Attach HART/Smart Field Devices to the Ovation I/O cards
- Build database point for the Field Devices
- Use AMS Suite to obtain data from the Field Devices
- Diagnose common problems and configuration errors

**Prerequisites**

Ovation - Data Acquisition – OV100

**Ovation HART & Smart Devices – Virtual - OV270V****Overview**

The OV270 - Virtual offered course was designed to provide the end-user with the skills to fully utilize the special features of I/O related to HART® and Smart Field Devices attached to the Ovation™ system. Students will learn the basic components of an Ovation system. Items discussed will include physical attachment of field devices to the Ovation I/O modules, and diagnosis of problems that may occur.

**Topics**

Upon successful completion of this course, using the reference material provided, the student will be able to:

- Identify the configuration of components in an Ovation™ system using HART®/Smart Devices
- Attach HART/Smart Field Devices to the Ovation I/O cards
- Build database point for the Field Devices
- Use AMS Suite to obtain data from the Field Devices
- Diagnose common problems and configuration errors

**Prerequisites**

Ovation - Data Acquisition – OV100

**Ovation Machinery Health Monitor Vibration - OV277****Overview**

This course will cover general concepts regarding the Ovation Machinery Health Monitor I/O module for measuring and recording plant vibration data. The student will configure the I/O module, install multiple types of vibration inputs and monitor the feedback data utilizing Emerson vibration sensors. Configuration of the Machine Works Application will also be discussed.

**Please note: At the current time this course does not cover the utilization of Bentley Nevada or other Manufacturers vibration sensors into the MHM Module.**

**Topics**

1. Introduction to MHM and types of Vibration Sensors
2. Inserting the MHM module into Ovation
3. Verification of IO module Firmware and updating firmware
4. Build Vibration points
5. Setting Up Ovation Machine Works Application

**Ovation SCADA System - OV280****Overview**

The OV280 - Virtual offered course was designed to provide the end-user with knowledge on the Ovation™ SCADA system. Student will learn the basic components of an Ovation SCADA system with discussions centered on SCADA servers, (RTU's) Remote Terminal Units, scan blocks, lines, ports, configuration tool, protocol analyzers and etc. Students will engage and establish communication using a variety of Allen-Bradley, MODBUS or DNP 3.0 protocols.

**Topics**

Upon successful completion of this course, using the reference material provided, the student will be able to:

- Identify the purpose and components in an Ovation™ SCADA system
- Identify the licensing requirements of an Ovation SCADA system
- Use the configuration tool to access and modify the system
- Analyze the communication protocols used with and Ovation SCADA system
- Utilize the protocol analyzer to interpret signal traffic between the SCADA Server and the RTU's
- Interpret scan block data
- Create Ovation graphics to interface to the Ovation SCADA system

**Prerequisites**

Ovation - Data Acquisition – OV100 and Ovation – Building Ovation Graphics – OV210

**Ovation Network Administration - OV320****Overview**

The OV320 course is designed to provide the end-user with a general understanding of networking concepts as well as Ovation™-specific network configurations for Fast Ethernet systems. Students will learn the basic networking skills required for general network administration and troubleshooting. Students will also be provided with hands-on knowledge of switch and route configurations for use in Ovation systems. This course will serve as one of the pre-requisites toward completing the Ovation Certification program.

**Topics**

Upon successful completion of this course, using the reference material provided, the student will be able to:

- Explore basic networking concepts including the OSI reference model, MAC addressing, TCP/IP, IP addressing, multicast addressing and local area networks
- Implement an Ovation™-specific network addressing scheme and network topology
- Define and explore basic network commands
- Define network devices and media and their relation to the OSI reference model
- Configure CISCO 2600 series routers, CISCO 3550 series switches and CISCO 2950 series switches for use in an Ovation network
- Configure and implement SNMP for Ovation
- Troubleshoot inter-networked systems with network tools and software
- Configure and apply third-party networking software

**Prerequisites**

Ovation – System Administration – OV230

### Ovation OPH Report Building – Virtual - OV246V



#### Overview

The OV246 - Virtual offered course was designed to teach the end-user how to configure and retrieve historical data using the Ovation™ Process historian (OPH) and Crystal Reports. Students will use the OPH Report Manager to define (Alarm, SOE, and Operator Event) reports. Using the same manager, students will learn how to configure (On-Demand, Triggered and Timed) reports. Students will also use Crystal Reports to create new report formats for use in the OPH Report Manager.

#### Topics

Upon successful completion of this course, using the reference material provided, the student will be able to:

- Describe the functions of the Ovation™ Process Historian and its related components
- Recognize the Ovation Process Historian Database Schema
- Understand the concept of a Relational Database Management System
- Schedule, automate and manipulate reports
- Distribute reports using printers and various output files
- Create custom reports using 3rd party applications such as Crystal Reports and MS Excel

#### Prerequisites

Ovation - Data Acquisition – OV100

### Ovation Operator – OV010

#### Overview

This course is designed to provide students with the ability to efficiently perform routine plant operations using the Ovation control system. Key topics include data acquisition, process analysis and control interfaces. Students will be able to use the tools provided to monitor processes controlled by the Ovation system and will learn to take appropriate actions to control these processes. This course is intended for all Operations personnel using the Ovation system.

#### Topics

Upon successful completion of the course and using the reference material provided, the student will be able to:

1. List the major components of the Ovation control system.
2. Display process diagram graphics.
3. Use process diagrams to interface with the control system
4. Evaluate point alarm conditions and acknowledge emergent alarms.
5. Differentiate various point types and use the Point Information system to find and edit point records.
6. Create live and historical trends.
7. Navigate through control tuning diagrams.
8. Analyze system problem conditions.
9. Use system reporting procedures.
10. Describe the function of Ovation application icons.
11. Demonstrate familiarity with menu bars and tool bars in various process diagram windows.
12. Demonstrate familiarity with the task bar and other Windows utilities.

### Ovation Operator – Virtual - OV010V



#### Overview

This course is designed to provide students with the ability to efficiently perform routine plant operations using the Ovation control system. Key topics include data acquisition, process analysis and control interfaces. Students will be able to use the tools provided to monitor processes controlled by the Ovation system and will learn to take appropriate actions to control these processes. This course is intended for all Operations personnel using the Ovation system.

#### Topics

Upon successful completion of the course and using the reference material provided, the student will be able to:

1. List the major components of the Ovation control system.
2. Display process diagram graphics.
3. Use process diagrams to interface with the control system
4. Evaluate point alarm conditions and acknowledge emergent alarms.
5. Differentiate various point types and use the Point Information system to find and edit point records.
6. Create live and historical trends.
7. Navigate through control tuning diagrams.
8. Analyze system problem conditions.
9. Use system reporting procedures.
10. Describe the function of Ovation application icons.
11. Demonstrate familiarity with menu bars and tool bars in various process diagram windows.
12. Demonstrate familiarity with the task bar and other Windows utilities.

### Ovation Excitation System - OV377

#### Overview

This course is for Ovation excitation. The course is intended for engineers and I&C Technicians that interface and maintain an Ovation excitation system and includes a review of the history and fundamentals of excitation, types of excitation, and the concepts of SCR bridges. The course discusses excitation and its elemental components, maintenance and troubleshooting, data retrieval and analysis. No required prerequisites as this course does not require knowledge of Ovation DCS. Course content is primarily by lecture with minimal hands-on equipment.

#### Topics

1. Review fundamentals of excitation
2. Use ovation applications to maintenance and troubleshooting

### Ovation Process Historian - OV245

#### Overview

The OV245 course was designed to teach the end-user how to configure the Ovation™ Process Historian (OPH) to retrieve real-time and historical data. The Ovation Process Historian hardware and database schema is reviewed in detail and various methods or data retrieval will be discussed including Report Manager, Crystal Reports, Historical Reviews and Trends.

#### Topics

Upon successful completion of this course, using the reference material provided, the student will be able to:

- Describe the functions of the Ovation™ Process Historian and related components
- Configure scanners and points for collection
- Recognize the Ovation Process Historian database scheme
- Understand the concept of a Relational Database Management System
- Install and configure the Ovation Process Historian Report Manager
- Schedule, automate and manipulate reports
- Create custom reports using third-party applications such as Crystal Reports, MS Excel, MS Access and SQL
- Create historical trends and build global trend groups
- Create historical Point, Alarm, Operator-Event, ASCII and common reviews
- Analyze the Ovation Process Historian with the diagnostic tools available

#### Prerequisites

Ovation - Data Acquisition – OV100

### Ovation Process Historian – Virtual - OV245V



#### Overview

The OV245 course was designed to teach the end-user how to configure the Ovation™ Process Historian (OPH) to retrieve real-time and historical data. The Ovation Process Historian hardware and database schema is reviewed in detail and various methods or data retrieval will be discussed including Report Manager, Crystal Reports, Historical Reviews and Trends.

### Ovation Process Historian – Virtual - OV245V – Continued...

#### Topics

Upon successful completion of this course, using the reference material provided, the student will be able to:

- Describe the functions of the Ovation™ Process Historian and related components
- Configure scanners and points for collection
- Recognize the Ovation Process Historian database scheme
- Understand the concept of a Relational Database Management System
- Install and configure the Ovation Process Historian Report Manager
- Schedule, automate and manipulate reports
- Create custom reports using third-party applications such as Crystal Reports, MS Excel, MS Access and SQL
- Create historical trends and build global trend groups
- Create historical Point, Alarm, Operator-Event, ASCII and common reviews
- Analyze the Ovation Process Historian with the diagnostic tools available

#### Prerequisites

Ovation - Data Acquisition – OV100

### Ovation Turbine Control - OV370

#### Overview

The OV370 is designed to afford the end-user with in-depth knowledge on the Ovation™ Turbine Control System (TCS). A hydraulic test stand with LVDT's and Servo Valves will be used to demonstrate turbine operation and graphics. The course includes defining I/O points, RVP and speed modules, calibration and troubleshooting exercises of the speed detector and valve positioner modules. Students will also demonstrate RVP card tuning.

#### Topics

Upon successful completion of this course, using the reference material provided, the student will be able to:

- Review the history of the steam turbine
- Review and evaluate typical turbine control logic
- Discuss the LVDT and speed probe functionality
- Configure I/O points for RVP and speed cards
- Configure and set up the RVP and speed I/O modules
- Using a hydraulic valve test stand connect an LVDT and servo valve for simulation

### Ovation Turbine Control - OV370 – Continued...

- Discuss troubleshooting procedures for LVDT's and servo valves
- Discuss and setup hyperlink terminal to RVP cards
- Perform LVDT tests and setup using the valve calibration graphic and hyperlink terminal
- Tune the RVP card in conjunction with the hydraulic test stand
- Using a speed wheel test the speed probes

#### Prerequisites

Ovation – Data Acquisition – OV100 and Ovation – Building and Maintaining Ovation Control – OV200

### Ovation Turbine Control – Virtual - OV370V



#### Overview

The OV370 is designed to afford the end-user with in-depth knowledge on the Ovation™ Turbine Control System (TCS). A hydraulic test stand with LVDT's and Servo Valves will be used to demonstrate turbine operation and graphics. The course includes defining I/O points, RVP and speed modules, calibration and troubleshooting exercises of the speed detector and valve positioner modules. Students will also demonstrate RVP card tuning.

#### Topics

Upon successful completion of this course, using the reference material provided, the student will be able to:

- Review the history of the steam turbine
- Review and evaluate typical turbine control logic
- Discuss the LVDT and speed probe functionality
- Configure I/O points for RVP and speed cards
- Configure and set up the RVP and speed I/O modules
- Using a hydraulic valve test stand connect an LVDT and servo valve for simulation
- Discuss troubleshooting procedures for LVDT's and servo valves
- Discuss and setup hyperlink terminal to RVP cards
- Perform LVDT tests and setup using the valve calibration graphic and hyperlink terminal
- Tune the RVP card in conjunction with the hydraulic test stand
- Using a speed wheel test the speed probes

#### Prerequisites

Ovation – Data Acquisition – OV100 and Ovation – Building and Maintaining Ovation Control – OV200

### Ovation SCADA System – Virtual - OV280V

#### Overview

The OV280 - Virtual offered course was designed to provide the end-user with knowledge on the Ovation™ SCADA system. Student will learn the basic components of an Ovation SCADA system with discussions centered on SCADA servers, (RTU's) Remote Terminal Units, scan blocks, lines, ports, configuration tool, protocol analyzers and etc. Students will engage and establish communication using a variety of Allen-Bradley, MODBUS or DNP 3.0 protocols.

#### Topics

Upon successful completion of this course, using the reference material provided, the student will be able to:

- Identify the purpose and components in an Ovation SCADA system
- Identify the licensing requirements of an Ovation SCADA system
- Use the configuration tool to access and modify the system
- Analyze the communication protocols used with and Ovation SCADA system
- Utilize the protocol analyzer to interpret signal traffic between the SCADA Server and the RTU's
- Interpret scan block data
- Create Ovation graphics to interface to the Ovation SCADA system

#### Prerequisites

Ovation - Data Acquisition – OV100 and Ovation – Building Ovation Graphics – OV210

### Ovation Security Administration - OV360

#### Overview

The OV360 course is designed as a guide for the end-user in the proper planning and installation of security for Ovation™ 2.4 and higher-level systems. Students will understand Ovation external and internal security concerns and learn how to apply safeguards. Students will install and configure Ovation compatible Windows Server 2003 Domain Controllers, Windows XP service packs and Windows security patches. Students will configure Ovation security using the Ovation Security Manager.

#### Topics

Upon successful completion of this course, using the reference material provided, the student will be able to:

- Identify and explain Ovation-specific internal and external security threats
- Plan and implement Ovation software installation including Windows 2003 Server, Windows service packs and Windows security patches
- Describe the function of the Ovation Security Manager
- Create and manage user accounts, computer accounts and Ovation roles and group policies
- Create and manage Ovation point security groups
- Manage and understand domain policies
- Create and manage Ovation domain administrators
- Design and implement a specific Ovation security configuration
- Explore the Windows group policy objects

#### Prerequisites

Ovation – System Administration – OV230

### Ovation Security Center - OV365

#### Overview

The OV365 consists of a suite of security modules designed to assist the end-user in reducing the cost of complying with the NERC CIP standards. The security modules functions include Vulnerability Scan and Patch Management (VSPM), Malware Prevention (MP) and Security Incident and Event Management (SIEM). The course covers the configuration, implementation and administration of the modules. The course supports Ovation™ 2.4 and newer for the Windows environment and Ovation 1.7.2 and newer for the Solaris environment.

#### Topics

Upon successful completion of this course, using the reference material provided, the student will be able to:

- Identify the modules of the Ovation Security center
- Demonstrate the Patch Management module
- Demonstrate the Malware Prevention module
- Demonstrate the Security Incident and Event Management module
- Demonstrate the Anti-Virus module
- Implement new Virtual Machines into the Virtual Host machine
- Recommend proper management techniques for the modules

#### Prerequisites

Ovation – Network Administration – OV320 and Ovation – Security Administration - OV360

### Ovation Security Center – Virtual - OV365V



#### Overview

The OV365 consists of a suite of security modules designed to assist the end-user in reducing the cost of complying with the NERC CIP standards. The security modules functions include Vulnerability Scan and Patch Management (VSPM), Malware Prevention (MP) and Security Incident and Event Management (SIEM). The course covers the configuration, implementation and administration of the modules. The course supports Ovation™ 2.4 and newer for the Windows environment and Ovation 1.7.2 and newer for the Solaris environment.

#### Topics

Upon successful completion of this course, using the reference material provided, the student will be able to:

- Identify the modules of the Ovation Security center
- Demonstrate the Patch Management module
- Demonstrate the Malware Prevention module
- Demonstrate the Security Incident and Event Management module
- Demonstrate the Anti-Virus module
- Implement new Virtual Machines into the Virtual Host machine
- Recommend proper management techniques for the modules

#### Prerequisites

Ovation – Network Administration – OV320 and Ovation – Security Administration - OV360

### Ovation Serial Link Controller/RLC - OV295

#### Overview

The OV295 - Virtual offered course provides the end-user with the knowledge of how to create specialized I/O links to non-Ovation™ field devices using both serial-link modules and the Ovation Ethernet Highway. Topics include configuring and loading link controller modules, creating third-party points, memory mapping, adding third-party drivers to controllers and the Ovation addressing requirements.

#### Topics

Upon successful completion of this course, using the reference material provided, the student will be able to:

- Understand the architecture and functionality of the Ovation Fast Switched Ethernet highway and the need to protect it from external sources
- Apply the RLC module
- Define MAC and IP addressing and Ethernet protocols
- Understand how Ethernet switches work
- Understand the various options for connecting third-party I/O to the Ovation highway
- Understand the Modbus register concept
- Understand the Modbus commands available in Ovation releases
- Apply and install Ovation Modbus drivers
- Apply and build Ovation point records for communication to Modbus
- Verify successful communications between Ovation and the PC Modbus simulation

#### Prerequisites

Ovation – Data Acquisition – OV100 and Ovation – Building and Maintaining Ovation Control – OV200

### Ovation Serial Link Controller/RLC – Virtual - OV295V



#### Overview

The OV295 - Virtual offered course provides the end-user with the knowledge of how to create specialized I/O links to non-Ovation™ field devices using both serial-link modules and the Ovation Ethernet Highway. Topics include configuring and loading link controller modules, creating third-party points, memory mapping, adding third-party drivers to controllers and the Ovation addressing requirements.

#### Topics

Upon successful completion of this course, using the reference material provided, the student will be able to:

- Understand the architecture and functionality of the Ovation Fast Switched Ethernet highway and the need to protect it from external sources
- Apply the RLC module
- Define MAC and IP addressing and Ethernet protocols
- Understand how Ethernet switches work
- Understand the various options for connecting third-party I/O to the Ovation highway
- Understand the Modbus register concept
- Understand the Modbus commands available in Ovation releases
- Apply and install Ovation Modbus drivers
- Apply and build Ovation point records for communication to Modbus
- Verify successful communications between Ovation and the PC Modbus simulation

#### Prerequisites

Ovation – Data Acquisition – OV100 and Ovation – Building and Maintaining Ovation Control – OV200



### Ovation Security Incident & Event Management Report Building - OV366

#### Overview

The OV366 course focuses on Security Incident and Event Management (SIEM) reporting through the Nitroview/McAfee SIEM module of the Ovation™ Security Center. The course centers on managing preloaded templates, manipulating the templates and also creating reports utilizing the report building features of the SIEM. Attendees will have a clear understanding of the available templates and demonstrate the ability to add, modify, delete and export reports upon completion.

#### Topics

Upon successful completion of this course, using the reference material provided, the student will be able to:

- Describe the basic functions of the Security Incident and Event Management tool
- Identify differences between Signature and Normalized ID's and how they are essential to reporting
- Identify the templates available and how they relate to different regulations and determine the most useful
- Locate the area where reports are saved
- Demonstrate knowledge of SIEM report building features
- Build reports using the correct templates
- Replace already built templates with custom templates
- Prepare reports for export to a Windows machine

#### Prerequisites

Ovation – Network Administration – OV320, Ovation - Security Administration – OV360 and Ovation - Security Center - OV365

### Ovation Security Incident & Event Management Report Building – Virtual - OV366V



#### Overview

The OV366 course focuses on Security Incident and Event Management (SIEM) reporting through the Nitroview/McAfee SIEM module of the Ovation™ Security Center. The course centers on managing preloaded templates, manipulating the templates and also creating reports utilizing the report building features of the SIEM. Attendees will have a clear understanding of the available templates and demonstrate the ability to add, modify, delete and export reports upon completion.

#### Topics

Upon successful completion of this course, using the reference material provided, the student will be able to:

- Describe the basic functions of the Security Incident and Event Management tool
- Identify differences between Signature and Normalized ID's and how they are essential to reporting
- Identify the templates available and how they relate to different regulations and determine the most useful
- Locate the area where reports are saved
- Demonstrate knowledge of SIEM report building features
- Build reports using the correct templates
- Replace already built templates with custom templates
- Prepare reports for export to a Windows machine

#### Prerequisites

Ovation – Network Administration – OV320, Ovation - Security Administration – OV360 and Ovation - Security Center - OV365

### Ovation Smart Process Global Performance Advisor - OV315

#### Overview

The OV315 course is designed for the end-user who will install, maintain and/or use the Global Performance Advisor (GPA) in power plants. It offers a good resource to those who have not purchased a GPA but are interested in understanding the true potential of a GPA. The course describes the capabilities and limitations of a GPA, hardware and software requirements and provides exercises to install, use and backup the GPA. Hands-on exercises to include: Building Feed-Water Heater Performance Calculations, Building Steam Turbine Performance Calculations and Building Condenser Calculations.

#### Topics

Upon successful completion of this course, using the reference material provided, the student will be able to:

- Identify and explain the GPA's capabilities and limitations
- Recognize the process data required to use the GPA effectively
- Understand GPA hardware and software requirements
- Load GPA software on a Workstation
- Create and reopen GPA projects and Workspaces
- Understand GPA tools and algorithms
- Understand Data Agents
- Create tags and import data
- Build and display example performance calculations
- Recognize communication techniques
- Understand backing up a GPA system

#### Prerequisites

Basic knowledge in power plant processes, Microsoft Windows Operating System, Ovation™ hierarchy of drops.

## Ovation Software Project - OV215

### Overview

The OV215 course was designed for end-users that require a good overall understanding of the Ovation™ system software utility packages. The course contains selected elements from the OV100, OV200, OV210, OV230 and OV300 courses. The topics covered include Ovation application functions: Developer Studio, process-point building, creating and modifying process control sheets and graphics, backing-up MMI's and the Domain Controller.

### Topics

Upon successful completion of this course, using the reference material provided, and the student will be able to:

- Identify the major components of an Ovation system
- Understand basic Ovation terminologies
- Demonstrate basic Ovation Operator functions
- Understand data movement within the Ovation system
- Understand the hierarchy and basic functions within the Ovation Developer Studio
- Use the Ovation Developer Studio to create process points
- Monitor control previously implemented in an Ovation system
- Interpret and tune implemented control using available tools
- Build and modify control schemes using the Developer Studio
- Interpret and modify tracking schemes to meet specific control requirements
- Recognize the relationship between control schemes and graphic diagrams
- Implement given control requirements using the Developer Studio
- Evaluate and determine the proper operation of a control scheme using the tools and methods provided

## Ovation Software Project - OV215



### Overview

The OV215 course was designed for end-users that require a good overall understanding of the Ovation™ system software utility packages. The course contains selected elements from the OV100, OV200, OV210, OV230 and OV300 courses. The topics covered include Ovation application functions: Developer Studio, process-point building, creating and modifying process control sheets and graphics, backing-up MMI's and the Domain Controller.

## Continued – OV215...

### Topics

Upon successful completion of this course, using the reference material provided, and the student will be able to:

- Identify the major components of an Ovation system
- Understand basic Ovation terminologies
- Demonstrate basic Ovation Operator functions
- Understand data movement within the Ovation system
- Understand the hierarchy and basic functions within the Ovation Developer Studio
- Use the Ovation Developer Studio to create process points
- Monitor control previously implemented in an Ovation system
- Interpret and tune implemented control using available tools
- Build and modify control schemes using the Developer Studio
- Interpret and modify tracking schemes to meet specific control requirements
- Recognize the relationship between control schemes and graphic diagrams
- Implement given control requirements using the Developer Studio
- Evaluate and determine the proper operation of a control scheme using the tools and methods provided

## Ovation Steam Turbine Mechanical Hydraulics - OV375

### Overview

The OV375 course is designed to give the end-user expert knowledge of the Emerson Mechanical Hydraulic products. Students will learn how to maintain the Emerson equipment.

### Topics

Upon successful completion of this course, using the reference material provided, the student will be able to:

- Understand the basic function and turbine components
- Identify primary hydraulic components, pumps, accumulators and etc.
- Trace components using hydraulic diagrams and drawings
- Identify and describe operational characteristics of directional, proportional and servo valves
- Identify common problems with LVDT, settings, RVP basic settings and etc.
- Understand the Speed Probe operation
- Demonstrate knowledge on hydraulic oil used - type, temperature, gasket materials, tank filling and the need for cleanliness.

### Prerequisite

Ovation - Turbine Control – OV370

## Ovation System Administration - OV230

### Overview

The OV230 course was designed for the end-user charged with maintaining the integrity of the Ovation™ DCS. Students who attend this course will learn all the configuration parameters of the Ovation Developer Studio tree (ex. Quality Configuration, Alarm Configuration, Point Review Configuration, Right Click Menu Configuration), as well as all right click functions (ex. Control functions, Search, Engineer, Back/Restore). Backups will be discussed in detail and each student will perform a database restore.

### Topics

Upon successful completion of the course, using the reference material provided, the student will be able to:

- Navigate and understand the Ovation™ Developer Studio
- Understand Ovation system licensing
- Implement Process control and user security in the Ovation system
- Apply system configuration changes to the Ovation system
- Add new and modify existing drops to the Ovation system
- Navigate and understand Ovation file systems, structure, sharing and security
- Backup the Ovation database and required files to various media
- Load an Ovation system
- Recover the Ovation database and required files from backup
- Understand upgrading and maintaining the Ovation hardware
- Use Developer Studio to implement given control requirements
- Map and share directories and files in the Windows environment

### Prerequisites

OV100 and OV200 highly recommended

### Ovation System Troubleshooting - Advanced - OV305

#### Overview

The OV400 course is offered to the end-user as a stand-alone or web-based exam or implemented with a pre-testing review at the Training Center. The student's proficiency is measured in areas related to database building, control implementation, control graphic linkage and troubleshooting on a system-wide basis. For both offerings, a multi-point examination is administered, and participants are required to achieve a grade score >80% to successful gain certification.

#### Topics

Upon completion of this course and achieving a successful level of competency in the online examination, the student will receive an Ovation™ certification award. This achievement affirms and recognizes that the student is fully cognizant and possesses the necessary skills to successfully engineer and maintain an Ovation control system for their organization. Student proficiency has been demonstrated in the following areas:

- Building saving and implementing the Oracle database
- Constructing control sheets using both Boolean and Analog logic
- Loading and configuring the Ovation™ Controller
- Designing graphics with control implementation
- Troubleshooting procedures as related to I/O and Controller modules

### Ovation Third Party ELC/Troubleshooting - OV296/OV300

#### Overview

The OV296/OV300 is a combined and condensed version of the two courses. Offered over a 5-day period the condensed course will enable the students to configure, network, troubleshoot the Ethernet Link Controllers, third-party I/O and the Ovation™ system as-a-whole. Students will configure an ELC in Developer Studio and learn best practices when troubleshooting the Ovation DCS.

#### Topics

Upon successful completion of this course, using the reference material provided, the student will be able to:

- Configure third-party points
- Explain the purpose of an ELC and its addressing
- Download firmware to ELC module
- Interpret DCS error messages
- Perform systematic approach to fault analysis; isolate & correct the fault

### Ovation Troubleshooting Using Applications - OV11

#### Overview

This 5 - day course, as the title suggests, is to understand how to troubleshoot using the alarm package, point information and control logic. Trending, point review and system viewer are also presented. These necessary software tools are available without the use of Ovation Studio. Explore a device's alarm through point information and/or control schemes. Understand a controller's fault diagnostics using system status and system viewer. This course is taught with the support of Ovation workstations and controllers

#### Topics

1. Review the major components of a typical Ovation Distributed Control System
2. Review usage of Ovation Applications
3. Utilize the Ovation Applications for live troubleshooting of processes and instruments

### Ovation Troubleshooting - OV300 Overview

The OV300 course is designed to provide the end-user with the skills and methods to troubleshoot and repair faults in the data acquisition and control functions of the Ovation™ system. Students will be required to isolate faults through-out the signal path- from field terminations to I/O modules, through the controller, across the network and onto the graphic display. Multiple problem scenarios will be presented.

#### Topics

Upon successful completion of this course, using the reference material provided, the student will be able to:

- Identify and resolve selected hardware, system administration and software problems
- Troubleshoot the system using documentation and available tools to analyze system faults or problem conditions
- Interpret system error messages
- Recognize and resolve problems with the system administration tool
- Using a systematic approach to fault analysis, isolate and correct selected network, port and printer faults

#### Prerequisites

Ovation - Data Acquisition – OV100, Ovation - Building and Maintaining Ovation Control – OV200 and Ovation - Building Ovation Graphics - OV210

### Ovation Troubleshooting – Virtual - OV300V

#### Overview

The OV300 course is designed to provide the end-user with the skills and methods to troubleshoot and repair faults in the data acquisition and control functions of the Ovation™ system. Students will be required to isolate faults through-out the signal path- from field terminations to I/O modules, through the controller, across the network and onto the graphic display. Multiple problem scenarios will be presented.

#### Topics

Upon successful completion of this course, using the reference material provided, the student will be able to:

- Identify and resolve selected hardware, system administration and software problems
- Troubleshoot the system using documentation and available tools to analyze system faults or problem conditions
- Interpret system error messages
- Recognize and resolve problems with the system administration tool
- Using a systematic approach to fault analysis, isolate and correct selected network, port and printer faults



### PLC Controller Maintenance Logic Developer – 7700

#### Overview

The Controller Maintenance - Logic Developer PLC course provides the student with the skills necessary to troubleshoot and repair faults in PLCs (90-30, 90-70, VersaMax, RX7i and RX3i).

The class is taught using Logic Developer PLC software, which is part of the Machine Edition family of products and features the PACSystems RX3i Controller. The focus is on interpreting existing ladder logic programs for troubleshooting purposes. Students are taught how to use the troubleshooting tools to determine where faults have occurred and how to correct them.

#### Topics

- Control System Fundamentals
- Application components and Logic Structure
- Basic Controller Variables, Data Types, and Numbering Systems
- Controller Scan
- Controller Hardware Overview
- System hardware components
- Finding Information
- Operating Proficy Machine Edition
- Orientation to programming environment and tools
- "Best-Kept Secrets"
- Projects and Targets
- Configuring Controller and IO
- Configure Controller, IO, and Option Modules
- Status indicators
- Assign Reference Addresses
- Hardware Reference View
- Import/Export
- Reports
- Working with Controllers
- Establish communications
- Project Validation
- Upload / Download / Verify
- Fault Tables
- Controller Status
- Working with Variables
- Variable concepts
- Variable Types
- Variable Access
- Variable attributes
- Introduction to LD Programming
- Basic operation
- LD Editor
- Basic LD logic elements (contacts, coils, counters, timers, and relational operators)
- Monitor LD logic execution
- Monitor Application Variables
- Data Watch, Data Monitor Utility, and Reference View Tables
- Modify application Variables
- Using Variable References
- Monitor Controller Without Original Project
- Modify Existing Program
- Working with Rungs

### PLC- 7700 – Continued...

Connecting LD Logic  
 Creating New Variables  
 Controller Equality Status  
 Equality Status indicators  
 Determine Controller component equality  
 How to gain Controller and Project Equality  
 Manage Controller Forces  
 Detect and locate Controller Forces  
 Clear and Unforce Variables  
 Application Troubleshooting  
 Using Search, Cross References, and References  
 Controller and IO Faults  
 Use Faults to diagnose system issues  
 Fatal and Nonfatal Faults  
 Clear and print Faults  
 Save Fault Tables to file

#### Audience

This course is intended for anyone who will be troubleshooting GE Intelligent Platforms PLC control systems using Proficy Logic Developer PLC Machine Edition software. The course is designed for electrical technicians, electricians, and/or engineers beginning to work with Logic Developer PLC, who will be tasked with modifying and maintaining PLC programs and hardware.

#### Prerequisites

Participants should be comfortable operating in a Microsoft Windows environment, and have a basic understanding of electrical/control fundamentals.

### PLC Controller Maintenance Logic Developer – 7700V



#### Overview

The Controller Maintenance - Logic Developer PLC course provides the student with the skills necessary to troubleshoot and repair faults in PLCs (90-30, 90-70, VersaMax, RX7i and RX3i).

The class is taught using Logic Developer PLC software, which is part of the Machine Edition family of products and features the PACSystems RX3i Controller. The focus is on interpreting existing ladder logic programs for troubleshooting purposes. Students are taught how to use the troubleshooting tools to determine where faults have occurred and how to correct them.

#### Topics

- Control System Fundamentals
- Application components and Logic Structure
- Basic Controller Variables, Data Types, and Numbering Systems
- Controller Scan
- Controller Hardware Overview
- System hardware components
- Finding Information
- Operating Proficy Machine Edition
- Orientation to programming environment and tools
- "Best-Kept Secrets"
- Projects and Targets
- Configuring Controller and IO

### PLC - 7700V – Continued...

- Configure Controller, IO, and Option Modules
- Status indicators
- Assign Reference Addresses
- Hardware Reference View
- Import/Export
- Reports
- Working with Controllers
- Establish communications
- Project Validation
- Upload / Download / Verify
- Fault Tables
- Controller Status
- Working with Variables
- Variable concepts
- Variable Types
- Variable Access
- Variable attributes
- Introduction to LD Programming
- Basic operation
- LD Editor
- Basic LD logic elements (contacts, coils, counters, timers, and relational operators)
- Monitor LD logic execution
- Monitor Application Variables
- Data Watch, Data Monitor Utility, and Reference View Tables
- Modify application Variables
- Using Variable References
- Monitor Controller Without Original Project
- Modify Existing Program
- Working with Rungs
- Entering LD Logic

Connecting LD Logic  
 Creating New Variables  
 Controller Equality Status  
 Equality Status indicators  
 Determine Controller component equality  
 How to gain Controller and Project Equality  
 Manage Controller Forces  
 Detect and locate Controller Forces  
 Clear and Unforce Variables  
 Application Troubleshooting  
 Using Search, Cross References, and References  
 Controller and IO Faults  
 Use Faults to diagnose system issues  
 Fatal and Nonfatal Faults  
 Clear and print Faults  
 Save Fault Tables to file

#### Audience

This course is intended for anyone who will be troubleshooting GE Intelligent Platforms PLC control systems using Proficy Logic Developer PLC Machine Edition software. The course is designed for electrical technicians, electricians, and/or engineers beginning to work with Logic Developer PLC, who will be tasked with modifying and maintaining PLC programs and hardware.

#### Prerequisites

Participants should be comfortable operating in a Microsoft Windows environment, and have a basic understanding of electrical/control fundamentals.



## PLC Controller Programming Logic Developer – 7701

### Overview

Learn programming for PACSystems, 90/70, 90/30, and VersaMax controllers in this Machine Edition class featuring the PACSystems RX3i Controller. This class covers programming techniques and the advanced features of the PACSystems Controller using Logic Developer PLC Machine Edition software. Starting with the controller software architecture, students are taught how to effectively develop control applications using building block concepts.

This course builds upon Object-Oriented concepts with PACSystems User-Defined Function Blocks (UDFBs), as well as the development of application components using Ladder Diagram (LD), Structured Text (ST), and Function Block Diagram (FBD) programming languages. An optional PROFINET module is available.

### Topics

- Control System Fundamentals
- Application components and Logic Structure
- Basic Controller Variables, Data Types, and Numbering Systems
- Controller Scan
- Operating Proficy Machine Edition
- Orientation to programming environment and tools
- "Best-Kept Secrets"
- Projects and Targets
- Machine Edition Options
- Working with Controllers
- Establish communications
- Project Validation
- Upload / Download / Verify
- Fault Tables
- Controller Status
- Controller Hardware Overview
- System hardware components
- Finding Information
- Configuring Controller and IO
- Configure Controller, IO, and Option Modules
- Status indicators
- Assign Reference Addresses
- Hardware Reference View
- Import/Export
- Reports
- Ladder Diagram Basics
- Ladder Diagram (LD) programming language basics
- Simple LD program with Contacts and Coils
- Assigning Variables
- Toolchest Drawer usage
- Proficy Machine Edition Toolchest
- Create and Share Toolchest Drawers

## PLC Controller Programming Logic Developer – 7701 Continued...

- Saving, using, and modifying Toolchest logic
- Universal Variables "\$"
- Online Monitoring Tools
- Logic Monitoring
- Data Watches
- Reference View Tables
- Data Monitor
- Online Application Modification
- Program changes while Controller is running
- Word-for-Word, Run Mode Store, and Test Edit
- Contacts and Coils
- Series and Parallel LD logic
- System Bits
- Find Variable references
- Monitor, modify, and force Boolean Variables
- Program Flow Operations
- Controller Block Architecture
- Operation of \_MAIN and Interrupt Blocks
- Create and call Program Blocks
- Including Toolchest Program Blocks
- Timers and Counters
- Timer and Counter Instance Data
- Conversion Operations
- Change data display formats in LD Editor
- Math Operations
- Typed Instructions
- Change Variable data values directly in LDEditor
- Relational Operations
- Understand the basic operation of LD Relational instructions.
- Data Operations
- Initialize application data using Data Move Functions
- Basic Shift Register operation
- Control Operations
- PID Function Block
- Service Request Function
- Display Controller ASCII String information
- Bit Operations
- Masked Compare Function
- Working with Variables
- Variable concepts
- Variable Types
- Variable Access
- Variable attributes
- FBD Programming
- Create FBD Blocks and Logic
- Logic solve order
- FBD Comments and Instructions
- Edit and wire FBD logic
- Negative Boolean flow
- Assign FBD logic variables
- Change online values
- Monitor FBD logic
- Call UDFBs
- Editor configuration options
- Print logic

## PLC Controller Programming Logic Developer – 7701 Continued...

- FBD programming considerations
- Programming Guidelines
- Program organization and naming conventions
- User Defined Function Blocks
- UDFB Input, Output, and Member Variables
- UDFB operation Create and monitor UDFB
- UDFB Toolchest considerations
- Update existing UDFB
- Introduction to PROFINET [OPTIONAL]
- PROFINET overview
- PROFINET resources

### Audience

This course is intended for those who are or will be involved in the development, modification, and troubleshooting of control systems using Proficy Logic Developer PLC and PACSystems Controllers.

### Prerequisites

Participants should be comfortable operating in a Microsoft Windows environment, and have a basic understanding of electrical/control fundamentals.

## PLC Operator Interface Programming QuickPanel & View – 7702

### Overview

The Operator Interface Programming - QuickPanel & View course familiarizes the student with operating in the Proficy View Machine Edition development environment, the QuickPanel+ machine level operator interface, creating operator interface graphical panels, writing scripts, configuring alarm & logging schemes, and running Projects on the operator interface device. Students are also introduced to the built-in Data Historian, Web Publishing, and Web Documents. An experienced instructor guides the student using demonstrations and hands on lab exercises.

### Topics

- Introduction to Operator Interfaces
- Basic HMI Types, Benefits of an Operator Interface.
- Introduction to QuickPanel+ and to Proficy View.
- Open HMI Project, Download and Run on QuickPanel+.
- Operating Proficy Machine Edition
- Use the Machine Edition environment and its tools: Navigator, Inspector, Companion, Editor Workspace, Feedback Zone, Data Watch, InfoViewer, & Toolchest.



**PLC – 7702 – Continued...**

- Use the Toolchest for HMI development.
- Create a new Project with Logic and HMI Components.
- Download and Run Project Using the Simulator.
- Going Online and use the Quick Test.
- Download and Run Project on QuickPanel+.
- Map the Machine Edition Controller's I/O.
- Create an HMI Project
- Working with View Targets in a Project.
- Configure PLC Access Drivers.
- Use Variables shared from a Controller Project.
- HMI Development Tools
- Build Operator Interface Panels using the Proficy View Graphic Editor and graphic drawing tools.
- Use Basic, Dynamic, Interactive, and Complex graphical objects.
- Animate objects and modify their appearance.
- Use Indexed Image and Message Grids.
- Create and Download an HMI Project Process Summary screen.
- Scripting
- Recognize how to apply scripts.
- Find help for scripting language commands, keywords, & functions.
- Create Panel, Application, & Touch Animation scripts.
- Validate, Run, & Debug an Active Script.
- Logging and Analyzing Data
- Create Logging Groups.
- Assign Project Variables to logging groups.
- Use TrendX chart to view logged data.
- Create a Chart object and view real-time data.
- Configure the View Historian Collector to archive device data.
- Alarms
- Differentiate variable alarm categories.
- Create and configure alarm groups.
- Assign alarms and alarm limits to Project Variables.
- Log Alarm Data and Track Alarm Events.
- Set up an alarm history file.
- Web Publishing and Access.
- Configure content for Web Access by publishing data.
- Create custom Web Documents.
- Interact with Project data through remote viewing.
- Conversion to QuickPanel+

- QuickPanel to QuickPanel+conversion considerations.
- Convert QuickPanel Project to QuickPanel+.

**Audience**

This course is designed for programmers, operators, and application designers who are beginning to work with the QuickPanel+ Operator Interface that is programmed using Proficy View, who will be tasked with developing, modifying, and maintaining Operator Interface applications.

**Prerequisites**

Participants should be comfortable operating in a Microsoft Windows environment, and have a basic understanding of control fundamentals.

### PLC Operator Interface Programming QuickPanel & View – 7702V

**Overview**

The Operator Interface Programming - QuickPanel & View course familiarizes the student with operating in the Proficy View Machine Edition development environment, the QuickPanel+ machine level operator interface, creating operator interface graphical panels, writing scripts, configuring alarm & logging schemes, and running Projects on the operator interface device. Students are also introduced to the built-in Data Historian, Web Publishing, and Web Documents. An experienced instructor guides the student using demonstrations and hands on lab exercises.

**Topics**

- Introduction to Operator Interfaces
- Basic HMI Types, Benefits of an Operator Interface.
- Introduction to QuickPanel+ and to Proficy View.
- Open HMI Project, Download and Run on QuickPanel+.
- Operating Proficy Machine Edition
- Use the Machine Edition environment and its tools: Navigator, Inspector, Companion, Editor Workspace, Feedback Zone, Data Watch, InfoViewer, & Toolchest.
- Use the Toolchest for HMI development.
- Create a new Project with Logic and HMI Components.
- Download and Run Project Using the Simulator.
- Going Online and use the Quick Test.
- Download and Run Project on QuickPanel+.
- Map the Machine Edition Controller's I/O.
- Create an HMI Project
- Working with View Targets in a Project.

- Configure PLC Access Drivers.
- Use Variables shared from a Controller Project.
- HMI Development Tools
- Build Operator Interface Panels using the Proficy View Graphic Editor and graphic drawing tools.
- Use Basic, Dynamic, Interactive, and Complex graphical objects.
- Animate objects and modify their appearance.
- Use Indexed Image and Message Grids.
- Create and Download an HMI Project Process Summary screen.
- Scripting
- Recognize how to apply scripts. Find help for scripting language commands, keywords, & functions.
- Create Panel, Application, & Touch Animation scripts.
- Validate, Run, & Debug an Active Script.
- Logging and Analyzing Data
- Create Logging Groups.
- Assign Project Variables to logging groups.
- Use TrendX chart to view logged data.
- Create a Chart object and view real-time data.
- Configure the View Historian Collector to archive device data.
- Alarms
- Differentiate variable alarm categories.
- Create and configure alarm groups.
- Assign alarms and alarm limits to Project Variables.
- Log Alarm Data and Track Alarm Events.
- Set up an alarm history file.
- Web Publishing and Access.
- Configure content for Web Access by publishing data.
- Create custom Web Documents.
- Interact with Project data through remote viewing.
- Conversion to QuickPanel+
- QuickPanel to QuickPanel+conversion considerations.
- Convert QuickPanel Project to QuickPanel+.

**Audience**

This course is designed for programmers, operators, and application designers who are beginning to work with the QuickPanel+ Operator Interface that is programmed using Proficy View, who will be tasked with developing, modifying, and maintaining Operator Interface applications.

**Prerequisites**

Participants should be comfortable operating in a Microsoft Windows environment, and have a basic understanding of control fundamentals.

## PLC PAC Productivity Suite - Introduction - 7703

### Overview

The Proficy Process Systems Fundamentals course is designed to provide a good working knowledge of Proficy Process Systems. This course explores the solution architecture, features and configuration tools from the controller, through Data Acquisition and Management to Visualization. Valuable hands-on lab exercises are provided to guide students through the building and modification of the system and its constituent components.

### Topics

- Introduction to Proficy Process Systems
- An overview of the Proficy Process Systems and its solutions.
- Eng. Workstation: Controllers & IO
- Use the EWS to prepare a PPS controller
- Creating a Project
- Configure fundamental project settings to prepare for development.
- Hardware Configuration
- Configure the controllers.
- Programming with Logic Developer
- Provide an orientation to the control programming environment.
- PPS Function Blocks
- Use PPS Function Blocks to build controller logic.
- Ethernet Global Data (EGD)
- See how the Global Namespace is constructed and driven by EGD.
- EWS- CIMPLICITY Project Essentials
- Prepare CIMPLICITY for PPS visualization.
- EWS- iFIX Project Essentials
- Prepare iFIX for PPS visualization.
- EWS- CIMPLICITY visualization
- Use CIMPLICITY to build displays using PPS faceplates and the Global Namespace.
- EWS iFIX visualization
- Use iFIX to build displays using PPS faceplates and the Global Namespace.
- Hardware and IO Networks
- Receive an overview of PPS Hardware and IO design principles.
- Controller-Based Alarming
- Set Alarming in the Controllers.
- Building Alarm Displays – CIMPLICITY
- Use EWS-CIMPLICITY to view alarms.

## PLC PAC Productivity Suite - Introduction – 7703 Continued...

- Building Alarm Displays – iFIX
- Use EWS- iFIX tools to build Alarm Displays.
- EWS utilities
- Explore useful EWS utilities for development, troubleshooting and maintenance.
- Build Reusable Code
- Discover the power of User Defined Function Blocks (UDFBs).
- Historian
- Archive important system data values.
- Change Management
- Control access and changes to system files. Provide version control of critical configuration files.
- Explore a Sample Project
- Work inside a fully functioning sample system.

### Audience

This course is designed for process, automation or instrumentation engineers and system integrators who will be developing, configuring and using applications on a fully integrated Proficy Process System.

### Prerequisites

Participants should have a working knowledge of Windows operating systems. Control Systems experience and knowledge is an asset.

### Regulators Gas Control Conference – 8000 CEUs – 3.2

#### Overview

This 4-1/2 day conference demonstrates the fundamentals of natural gas regulators in gas pressure control. This course emphasizes natural gas distribution and also covers natural gas transmission. Students who complete this conference will be able to:

- evaluate the difference between direct-operated and pilot-operated regulators
- evaluate the different methods of overpressure protection
- properly size regulators and relief valves for natural gas applications
- troubleshoot a wide variety of regulator types

#### Topics

- Self-Operated Regulator Fundamentals
- Pilot-Operated Regulator Fundamentals
- Two-Path vs. Unloading Style Pilots
- Regulator Sizing and Selection
- Overpressure Protection Methods
- Monitor Methods and Sizing
- Sizing and Selection of Relief Valves
- Pressure Factor Measurement
- Troubleshooting Regulators
- Failure Analysis
- Recommended Installation Practices
- Aerodynamic Noise Theory, Treatment Methods and Technologies
- Regulator Olympics - 3 Troubleshooting Challenges\*

A panel of Emerson marketing, engineering, and new product design engineers will discuss trends and needs in the Natural Gas market.

\*The Regulator Olympics divides the class members into teams to participate in troubleshooting regulators—diagnosing district station problems, changing monitor modes, and working on commercial service regulators.

#### Audience

This conference is for those responsible for the selection, application, and operation of regulators in the natural gas industry.

#### Prerequisites

At least one year's experience in the field of natural gas regulators is recommended.

### Regulators Gas Control Seminar - Virtual - 8005V CEUs – 1.8



#### Overview

This virtual seminar is for those responsible for the selection, application, and operation of regulators in the natural gas industry. The seminar will last for 5 half-days and be presented Monday through Friday, 8:00 a.m. - noon each day. The seminar emphasizes natural gas distribution and also covers natural gas transmission.

#### Topics

- Self-Operated Regulators
- Regulator Design & Technology
- Testing Regulators
- Disassembling regulators
- Sizing
- Pilot-Operated Regulators
- Overpressure Protection
- Safety Relief Valves
- Second Layers of Overpressure Protection
- Testing Relief Valves
- Wide-Open Monitors and Working Monitors
- Troubleshooting
- Safety Relief
- Severe Service

#### Audience

Natural Gas Industry Engineers and Engineering Management who work with Pressure Relief Valves and Regulators

#### Prerequisites

None

### Regulators & Relief Valves Gas Regulator – 1100 CEUs - 2.1

#### Overview

This 3-day course is designed primarily for technicians responsible for the installation and maintenance of natural gas regulators. Emphasizing hands-on training, this course teaches students to install, troubleshoot, and adjust gas regulators. Students who complete this conference will be able to:

- perform maintenance on regulators and relief valves
- troubleshoot field problems

#### Topics

- Self-Operated Regulator
- Pilot-Operated Regulators
- Overpressure Protection
- Series Regulation
- Monitors
- Slam Shut Options
- Regulator Failure Analysis
- Troubleshooting and Installation

#### Audience

This course is designed primarily for technicians responsible for the installation and maintenance of natural gas regulators.

#### Prerequisites

At least one year's field experience with natural gas regulators is recommended.

### Regulators & Relief Valves Gas Regulator – Virtual - 1100V CEUs - 2.1



#### Overview

This 3-day course is designed primarily for technicians responsible for the installation and maintenance of natural gas regulators. Emphasizing hands-on training, this course teaches students to install, troubleshoot, and adjust gas regulators. Students who complete this conference will be able to:

- perform maintenance on regulators and relief valves
- troubleshoot field problems

#### Topics

- Self-Operated Regulator
- Pilot-Operated Regulators
- Overpressure Protection
- Series Regulation
- Monitors
- Slam Shut Options
- Regulator Failure Analysis
- Troubleshooting and Installation

#### Audience

This course is designed primarily for technicians responsible for the installation and maintenance of natural gas regulators.

#### Prerequisites

At least one year's field experience with natural gas regulators is recommended.

### Regulators & Relief Valves Principles of Self-Operated Regulators - e7601 CEUs - 0.5



#### Overview

This online training includes audio presentations to provide an in-depth overview of available Mimic features and applications. Better understand how to easily build and maintain your Mimic simulation system. Note: Course access is 12 months.

#### Topics

- Accessing and starting Mimic applications
- Setup procedures for Simulated I/O Drivers
- Navigation in Mimic Explorer
- Modeling in the Simulation Studio interface
- Discrete and Analog modeling
- Building unit operation models
- Configuring Advanced Modeling Objects
- Database generation utilities
- Using Operator Training Manager
- Building training scenarios and instructor screens
- Freezing and restoring process snapshots

#### Audience

Operators, supervisors, and managers responsible for operating and maintaining the Mimic simulation system.

### Regulators & Relief Valves Industrial Regulator - 1102 CEUs - 2.1

#### Overview

Emphasizing hands-on training, this course teaches students to install, troubleshoot, and adjust regulators specific to the Industrial Market.

#### Topics

Students who complete this course will be able to do the following:

- perform maintenance on regulators
- troubleshoot field problems

#### Audience

This course is designed primarily for technicians responsible for the installation and maintenance of industrial regulators.

### Regulators & Relief Valves Pressure/Vacuum Relieving Equipment – 1114 CEUs – 2.1

#### Overview

As the world-wide leading provider of precision pressure relief devices with such brands as Anderson Greenwood, Crosby, and Varec, we are committed to provide the technical assistance needed to help designers and engineers meet pressure vessel code requirements and attain optimum pressure relief valve performance. Since 1970, these seminars have been conducted to assist in training for the design, installation, and operation of effective pressure relief systems. The seminar also serves as an excellent refresher course for experienced personnel and offers unique forums for the exchange of information, applications, and solutions.

#### Topics

- Principles of Operation
- ASME Pressure Vessel Code Requirements
- API Storage Tank Standards and Recommended Practices
- Advantages and Limitations of PRV Types
- Installation and Applications of Pressure Relief Devices
- Pressure Relief Device Hands-on Circuit
- Assembly and Testing Facility Tour
- Operational Demonstrations of Devices at our ASME Certified Training Laboratory
- Choice of Pressure Relief Valve Sizing and Selection Workshop or Pressure Relief Valve Hands-on Troubleshooting, Inspection, Maintenance, and Reliability Workshop.

#### Audience

Customers of Anderson Greenwood, Crosby, and Varec. This would include designers and engineers.

### Regulators & Relief Valves Gas Regulators Troubleshooting – 1106 CEUs - 2.1

#### Overview

This 3-day course provides intensive hands-on training using the same regulators that are commonly used in the field. Actual gas regulator problems are simulated in the workshops, challenging the student to efficiently diagnose problems and restore the regulator to proper operation. Students who complete this course will:

- efficiently and safely troubleshoot common regulator operational performance problems
- understand the influence of the service environment on regulator performance
- understand the importance of correct installation procedures
- understand the role of correct sizing as it impacts regulator performance
- perform maintenance on regulators and relief valves
- troubleshoot field problems

#### Topics

- Review:
  - Self-Operated Regulator Fundamentals
  - Pilot-Operated Regulator Fundamentals
  - Overpressure Protection
- Sizing Overview for Technicians
- Regulator Troubleshooting Principles, Procedures, and Best Practice
  - Failure Analysis
  - Stability Issues
  - Installation Practices
  - Pilot Interchangeability Practices
  - Advanced Monitor Operations and Maintenance

#### Audience

This course is designed primarily for technicians with responsibility for installing, maintaining, and troubleshooting gas regulators.

#### Prerequisites

1100 Gas Regulator Technician recommended but not required.

### Remote Automation Solutions Electronic Gas Measurement API 21.1 Standard & Emerson Flow Computer - RA1100 CEUs – 1.4

#### Overview

This 2-day course will provide a hands-on overview of API 21.1 standard for Electronic Gas Measurement and the Emerson FB1000/2000 Series Flow Computers. Participants are presented with the API standards while engaging in direct hands-on correlation to the flow computer's features for measurement, auditing and archiving, and more. Gain the necessary knowledge to effectively installation, configuration and maintenance. Each student will be provided with a PC with preinstalled software and all necessary hardware and courseware for the duration of the class. Participants are encouraged to bring their PC.

#### Topics

##### Introduction

- Hardware Options
- I/O Options
- Calibrating the AI and AO
- FBxConnect Software
- Elements of Basic Configuration

##### Configuring the Flow Computer

- Communication Basics
- Setting the Flow Computer clock
- Alarm and Events Logs
- History layout
- Backing Up and Restoring Configurations
- Logic Blocks / Math Blocks
- Final Exercise
- Summary of course

#### Audience

This Remote Automation Solutions course is for engineers, technicians, and others involved with the configuration and operation of the FBXX series products.

#### Prerequisites

Participants should have a working knowledge of their application/process and should also have advanced PC knowledge and be thoroughly familiar with Microsoft Windows operating systems.

### Remote Automation Solutions Electronic Gas Measurement API 21.1 Standard & Emerson Flow Computer - Virtual - RA1100V CEUs – 1.4



#### Overview

This 2-day course will provide a hands-on overview of API 21.1 standard for Electronic Gas Measurement and the Emerson FB1000/2000 Series Flow Computers. Participants are presented with the API standards while engaging in direct hands-on correlation to the flow computer's features for measurement, auditing and archiving, and more. Gain the necessary knowledge to effectively installation, configuration and maintenance. Each student will be provided with a PC with preinstalled software and all necessary hardware and courseware for the duration of the class. Participants are encouraged to bring their PC.

#### Topics

##### Introduction

- Hardware Options
- I/O Options
- Calibrating the AI and AO
- FBxConnect Software
- Elements of Basic Configuration

##### Configuring the Flow Computer

- Communication Basics
- Setting the Flow Computer clock
- Alarm and Events Logs
- History layout
- Backing Up and Restoring Configurations
- Logic Blocks / Math Blocks
- Final Exercise
- Summary of course

#### Audience

This Remote Automation Solutions course is for engineers, technicians, and others involved with the configuration and operation of the FBXX series products.

#### Prerequisites

Participants should have a working knowledge of their application/process and should also have advanced PC knowledge and be thoroughly familiar with Microsoft Windows operating systems.

### Remote Automation Solutions ControlWave Troubleshooting Configuration - RA331 CEUs - 1.8

#### Overview

This 2-1/2-day hands-on course covers the hardware, troubleshooting, configuration and maintenance of the ControlWave product family. This course will equip you with the necessary knowledge and practice needed to troubleshoot common problems and configure the ControlWave hardware. Learn to utilize software application programs to perform diagnostics and monitor live data and communication statistics.

#### Topics

- Overview of ControlWave Hardware
- Overview of OpenBSI Software Utilities
- Basic Troubleshooting
- Basic ControlWave Configuration

#### Audience

Field personnel whose responsibilities may include: installation, wiring, start-up, troubleshooting, configuration or maintenance of the ControlWave products. An individual who seeks a more thorough understanding of the ControlWave products.

#### Prerequisites

Participants must be thoroughly familiar with Windows 2000/ XP or later versions. Participants should have formal instrument technician training and a working knowledge of their application/process.



**Remote Automation Solutions  
ControlWave Troubleshooting  
Configuration - Virtual - RA331V  
CEUs - 1.8**



**Overview**

This 2-1/2-day hands-on course covers the hardware, troubleshooting, configuration and maintenance of the ControlWave product family. This course will equip you with the necessary knowledge and practice needed to troubleshoot common problems and configure the ControlWave hardware. Learn to utilize software application programs to perform diagnostics and monitor live data and communication statistics.

**Topics**

- Overview of ControlWave Hardware
- Overview of OpenBSI Software Utilities
- Basic Troubleshooting
- Basic ControlWave Configuration

**Audience**

Field personnel whose responsibilities may include: installation, wiring, start-up, troubleshooting, configuration or maintenance of the ControlWave products. An individual who seeks a more thorough understanding of the ControlWave products.

**Prerequisites**

Participants must be thoroughly familiar with Windows 2000/ XP or later versions. Participants should have formal instrument technician training and a working knowledge of their application/process.

**Remote Automation Solutions  
ControlWave Designer - Introduction -  
RA441  
CEUs - 3.2**

**Overview**

This 4-1/2-day hands-on course covers programming the ControlWave product family using the ControlWave Designer IEC61131-3 software and the Designer function block library. This course will provide the participant the necessary knowledge and skills required to define and control inputs and outputs of related real-world applications. Participants will generate and debug simple control strategy programs using Function Block, Ladder Logic, Structured Text, and Sequential Function Chart programming. They will also learn the basics of ControlWave communications, historical data storage, alarm-ing, hardware configurations and much more.

**Topics**

- Ladder Logic
- Structured Text
- Function Block Diagram
- Creating User Function Blocks

**Audience**

Personnel responsible for programming and debugging in ControlWave Designer programming software.

**Prerequisites**

Participants must have a strong working knowledge of personal computers and Windows XP or a later version. Participants should have a strong working knowledge of their application/process

**Remote Automation Solutions  
ControlWave Designer - Introduction -  
Custom - RA441C**

**Overview**

This ControlWave Designer 2 day course provides the knowledge and skill required to define and control inputs and outputs of related real world applications, including basic communications and troubleshooting in an Interactive Plant Environment (IPE), with live equipment. The class project will help students generate and debug simple control strategy programs using Function Block, Ladder Logic, and Structured Text programming languages.

**Topics**

**DAY 1**

- ControlWave Designer Overview
- ControlWave File Conventions
- Program Organization Units (POU)
- Functions, Function Blocks, Programs
- Variables/ Types
- Tasks/ Program Instances
- Configuring ControlWave Flash Memory Parameters

**DAY 2**

- I/O Configuration to Field Equipment
- Verify that Values on Software match Field Equipment and Troubleshoot as needed
- Programming Languages Ladder Logic, Function Block Diagram, Structured Text
- Class Exercise with PID, verify Control Valve Responds accordingly based on changes in Pressure in IPE.
- ALARM Function Blocks
- Programming for Alarms
- Programming for Audits/ Archives
- Debugging Techniques on Live Equipment
- Troubleshooting tips
- Establishing User Libraries
- Creating User Library of Function Blocks

**Audience**

A hands-on course that will give you as much exposure to ControlWave programming as possible in the shortest amount of time. Using the Interactive Plant Environment you will be connected to field devices and see live values from those devices as well as troubleshooting when necessary.

**Prerequisites**

Participants must have a strong working knowledge of personal computers and Windows XP or a later version. Participants should have a strong working knowledge of their application/process

**Remote Automation Solutions  
ControlWave Designer - Introduction -  
Virtual - RA441V  
CEUs - 3.2**



**Overview**

This 4-1/2-day virtual course covers programming the ControlWave product family using the ControlWave Designer IEC61131-3 software and the Designer function block library. This course will provide the participant the necessary knowledge and skills required to define and control inputs and outputs of related real world applications. Participants will generate and debug simple control strategy programs using Function Block, Ladder Logic, Structured Text, and Sequential Function Chart programming. They will also learn the basics of ControlWave communications, historical data storage, alarm-ing, hardware configurations and much more.

**Topics**

- Ladder Logic
- Structured Text
- Function Block Diagram
- Creating User Function Block

**Audience**

Personnel responsible for programming and debugging in ControlWave Designer programming software

**Prerequisites**

Participants must have a strong working knowledge of personal computers and Windows XP or a later version. Participants should have a strong working knowledge of their application/process

**Remote Automation Solutions  
ControlWave Designer Programming -  
RA440  
CEUs - 1.8**

**Overview**

A hands-on course that will give you as much exposure to ControlWave programming as possible in the shortest amount of time. The ControlWave Designer short 2 ½ day course provides the knowledge and skill required to define and control inputs and outputs of related real-world applications, including basic communications and troubleshooting. The class project will help students generate and debug simple control strategy programs using Function Block, Ladder Logic, and Structured Text programming languages, including programming for Modbus communications.

**Topics**

- Understand How IEC-61131-3, ControlWave Designer and On-Line Utilities Work
- Master Skills Necessary to Create a Program for ControlWave Controllers
- Learn the Bristol Library of Function Blocks for Measurement, Calculations, Process Control, Data Storage
- Understand OpenBSI Communications Software
- Master How to Establish Ethernet/IP Communications using ControlWave Designer
- Learn to Program Polling and Data Transfers in BSAP and an I/O Environment
- Understand How to Define a Hierarchical Network of ControlWave Controllers using NetView
- Understand the Configuration of Communication via other Protocols such as Modbus

**Prerequisites**

Participants must have a strong working knowledge of personal computers and Windows XP or a later version. Participants should have a strong working knowledge of their application/process. Participants should have programming experience (this course is not recommended for beginner programmers).

**Remote Automation Solutions  
ControlWave Designer Programming -  
Virtual - RA440V  
CEUs - 1.8**



**Overview**

A virtual course that will give you as much exposure to ControlWave programming as possible in the shortest amount of time. The ControlWave Designer short 2 ½ day course provides the knowledge and skill required to define and control inputs and outputs of related real-world applications, including basic communications and troubleshooting. The class project will help students generate and debug simple control strategy programs using Function Block, Ladder Logic, and Structured Text programming languages, including programming for Modbus communications

**Topics**

- Understand How IEC-61131-3, ControlWave Designer and On-Line Utilities Work
- Master Skills Necessary to Create a Program for ControlWave Controllers
- Learn the Bristol Library of Function Blocks for Measurement, Calculations, Process Control, Data Storage
- Understand OpenBSI Communications Software
- Master How to Establish Ethernet/IP Communications using ControlWave Designer
- Learn to Program Polling and Data Transfers in BSAP and an I/O Environment
- Understand How to Define a Hierarchical Network of ControlWave Controllers using NetView
- Understand the Configuration of Communication via other Protocols such as Modbus

**Prerequisites**

Participants must have a strong working knowledge of personal computers and Windows XP or a later version. Participants should have a strong working knowledge of their application/process. Participants should have programming experience (this course is not recommended for beginner programmers).

**Remote Automation Solutions  
CONTROLWAVE® Designer  
Programming Accelerated - RA443  
CEUs - 3.2**

**Overview**

Save time and money by attending this fast-paced, hands-on course for programming the ControlWave® product family using IEC-61131-3 standard software and Bristol®-supplied functions. This course provides you with the knowledge and skills required to define and control inputs and outputs of related real-world applications, including communications and troubleshooting. Students will generate and debug control strategy programs using several programming languages while learning the basics of ControlWave network communications, historical data storage, alarming, and hardware configurations, including MODBUS communications.

**Topics**

- Flash Memory Communication Configuration via Local View
- Ladder Logic
- Function Block Diagram
- Debugging Techniques
- Programming for Audits/Archives/Alarms
- Establishing User Libraries

**Audience**

Personnel responsible for the establishing of communication interfaces to ControlWave Automation products

**Prerequisites**

- Participants must have a strong working knowledge of personal computers and Windows 2000/ XP or a later version
- Participants must have a strong working knowledge of their application/ process
- Participants should have some programming experience.
- Participants should have completed "Creating a Simple Project".

**Remote Automation Solutions  
ControlWave® Gas Measurement  
Products - RA445  
CEUs - 1.8**

**Overview**

The ControlWave Gas Measurement 2-1/2-day course provides participants with a thorough understanding of configuring the ControlWave® GFC, EFM, and XFC Flow Computers for single or multiple-run gas measurement. As a hands-on course, students will use TechView to collect historical logs, calibrate internal and external pressure sensors, and gain troubleshooting techniques for real world applications.

**Topics**

- Hardware Configuration
- TechView Software Overview
- Log Collection
- Troubleshooting
- Configuring 4-Run Gas Application

**Audience**

Personnel responsible for the installation, wiring, start-up, configuration and maintenance of ControlWave gas flow computers

**Prerequisites**

The following are suggested, not mandatory:

- Participants should have a working knowledge of their application/process
- Participants should be familiar with Windows 2000/ XP or later versions and possess a general knowledge of gas measurement and production

**Remote Automation Solutions  
ControlWave Modbus Programming for  
ControlWave Devices - Virtual - RA444V  
CEUs - 0.4**



**Overview**

This 4-hour Virtual Course provides the knowledge and skill required to programming for Modbus communications in ControlWave Devices. Each student will be provided remote access to a PC (ControlWave Designer installed), and connection to ControlWave device for programming and downloading capability.

**Audience**

This course is for engineers, technicians, and others involved with programming the ControlWave for Modbus communications.

**Prerequisites**

Participants should have:

- Completed course RA441 or have sufficient programming experience in ControlWave Designer.
- A strong working knowledge of personal computers and Windows XP or a later version.
- A strong working knowledge of their application/process.

**Remote Automation Solutions  
ControlWave® Station Manager  
Configuration - RA447  
CEUs - 1.8**

**Overview**

The Gas Measurement Applications for technicians 2 ½ day course provides students with a thorough understanding of configuration of the Station Manager application for the ControlWave Micro. Participants will use TechView to configure the ControlWave Micro application to establish multiple gas measurement and control scenarios, historical log collections, calibrations, and much more.

**Topics**

- Hardware Overview
- Writing/Saving Configurations
- I/O Controls
- MVT Calibration
- Station Configuration

**Audience**

Personnel responsible for the installation, wiring, start-up, configuration and maintenance of ControlWave gas flow computers

**Prerequisites**

The following are suggested, not mandatory:

- Participants should have a working knowledge of their application/process.
- Participants should be familiar with Windows XP or later versions and poses a general knowledge of gas measurement and production.

### Remote Automation Solutions ControlWave® Station Manager Configuration - Virtual - RA447V CEUs - 1.8



#### Overview

The Gas Measurement Applications for technicians 2 ½ day course provides students with a thorough understanding of configuration of the Station Manager application for the ControlWave Micro. Participants will use TechView to configure the ControlWave Micro application to establish multiple gas measurement and control scenarios, historical log collections, calibrations, and much more.

#### Topics

- Hardware Overview
- Writing/Saving Configurations
- I/O Controls
- MVT Calibration
- Station Configuration

#### Audience

Personnel responsible for the installation, wiring, start-up, configuration and maintenance of ControlWave gas flow computers

#### Prerequisites

The following are suggested, not mandatory:

- Participants should have a working knowledge of their application/process.
- Participants should be familiar with Windows XP or later versions and possess a general knowledge of gas measurement and production.

### Remote Automation Solutions ControlWave Designer - Introduction - Custom - RA441C CEU's - 1.4

#### Overview

This ControlWave Designer 2.5 day course provides the knowledge and skill required to define and control inputs and outputs of related real world applications, including basic communications and troubleshooting in an Interactive Plant Environment (IPE), with live equipment. The class project will help students generate and debug simple control strategy programs using Function Block, Ladder Logic, and Structured Text programming languages

#### Topics

##### DAY 1

- ControlWave Designer Overview
- ControlWave File Conventions
- Program Organization Units (POU)
- Functions, Function Blocks, Programs
- Variables/ Types
- Tasks/ Program Instances
- Configuring ControlWave Flash Memory Parameters

### Remote Automation Solutions ControlWave Designer - Introduction - Custom - RA441C – Continued...

#### DAY 2

- I/O Configuration to Field Equipment
- Verify that Values on Software match Field Equipment and Troubleshoot as needed
- Programming Languages Ladder Logic, Function Block Diagram, Structured Text
- Class Exercise with PID, verify Control Valve Responds accordingly based on changes in Pressure in IPE.
- ALARM Function Blocks
- Programming for Alarms
- Programming for Audits/ Archives
- Debugging Techniques on Live Equipment
- Troubleshooting tips
- Establishing User Libraries
- Creating User Library of Function Blocks

#### Audience

A hands-on course that will give you as much exposure to ControlWave programming as possible in the shortest amount of time. Using the Interactive Plant Environment you will be connected to field devices and see live values from those devices as well as troubleshooting when necessary.

#### Prerequisites

Participants must have a strong working knowledge of personal computers and Windows XP or a later version. Participants should have a strong working knowledge of their application/process. Participants should have programming experience (this course is not recommended for beginning programmers)

### Remote Automation Solutions ControlWave® Designer Communication Programming – RA442 CEUs - 3.2

#### Overview

This 4-1/2-day course is a continuation of ControlWave® Designer Fundamentals course focusing on networking and communications. Participants will program the ControlWave to communicate to other devices in a network, as well as transfer and receive signal lists using serial and IP communications. Other application software will be utilized to configure, establish, and debug communications with these devices. Participants will learn the advanced methods of communicating to Bristol and ControlWave devices using Client/Server modules, and to Modbus protocol devices using custom function blocks

#### Topics

- Client/Server Function Blocks
- Modbus Programming
- System Communication Variables
- BSAP Network Communications

### Remote Automation Solutions ControlWave® Designer Communication Programming – RA442 – Continued...

#### Audience

Personnel responsible for the establishing of communication interfaces to ControlWave Automation products

#### Prerequisites

Successful completion of course RA441, ControlWave Designer Fundamentals. Participants must have a strong working knowledge of personal computers and Windows XP or later version. Participants should have a strong working knowledge of their application/process

### Remote Automation Solutions ControlWave® Designer Communication Programming - RA442V CEUs - 3.2



#### Overview

This 4-1/2-day virtual course is a continuation of ControlWave® Designer Fundamentals programming course focusing on networking and communications. Participants will program the ControlWave to communicate to other devices in a network, as well as transfer and receive signal lists using serial and IP communications. Other application software will be utilized to configure, establish, and debug communications with these devices. Participants will learn the advanced methods of communicating to Bristol and ControlWave devices using Client/Server modules, and to Modbus protocol devices using custom function blocks

#### Topics

- Client/Server Function Blocks
- Modbus Programming
- System Communication Variables
- BSAP Network Communications

#### Audience

Personnel responsible for the establishing of communication interfaces to ControlWave Automation products.

#### Prerequisites

Successful completion of course RA441, ControlWave Designer Fundamentals. Participants must have a strong working knowledge of personal computers and Windows XP or later version. Participants should have a strong working knowledge of their application/process

**Remote Automation Solutions  
ControlWave® Designer Programming  
Accelerated - RA443V  
CEUs - 4.5**



**Overview**

Save time and money by attending this fast-paced, virtual course for programming the ControlWave® product family using IEC-61131-3 standard software and Bristol-supplied functions. This course provides you with the knowledge and skills required to define and control inputs and outputs of related real world applications, including communications and troubleshooting. Students will generate and debug control strategy programs using several programming languages while learning basics of CONTROLWAVE® network communications, historical data storage, alarming and hardware configurations, including MODBUS communications.

**Topics**

- Flash Memory Communication Configuration via Local View
- Ladder Logic
- Function Block Diagram
- Debugging Techniques
- Programming for Audits/Archives/Alarms
- Establishing User Libraries

**Audience**

Personnel responsible for the establishing of communication interfaces to ControlWave products.

**Prerequisites**

Participants must have strong working knowledge of personal computers and Windows 2000/XP or a later version. Participants must have a strong working knowledge of their application/process. Participants should have some programming experience.

**Remote Automation Solutions Creating  
Your Own Function Block Using  
ControlWave Designer - RA446V  
CEUs - 0.4**



**Overview**

This 4-hour virtual course provides the knowledge and skill required to create your own Function Block from existing Function Blocks using ControlWave Designer software to test and trouble shoot the final project.

Each student will be provided remote access to a PC (ControlWave Designer installed).

**Audience**

This course is for engineers, technicians and others involved with programming ControlWave.

**Prerequisites**

Participants should have completed courses RA440 and RA441 or have sufficient programming experience in ControlWave Designer. Participants should have a strong working knowledge of personal computers and Windows 7 or a later version. Participants should have a strong working knowledge of their application/process.

**Remote Automation Solutions  
FloBoss™ Configuration & Operations -  
RA1220  
CEUs - 3.2**

**Overview**

This 4-1/2-day course will provide an overall working knowledge of the FloBoss™ 103, FloBoss 107. Participants are presented with a comprehensive view of the FloBoss 103/107 hardware and ROCLINK800 software to obtain the necessary knowledge needed to effectively install, configure and maintain the FloBoss 103/107 products. Each student will be provided with a PC (ROCLINK800 preinstalled), a FloBoss 107RTU, a communications cable and a workbook for the duration of the class. However, participants are encouraged to bring their laptop to class.

**Topics**

- Flow Measurement Review
- FloBoss™ 103/107 Hardware Overview
- FloBoss
  - Check and Set ROC Information
  - Check and Set ROC System Flags
  - Communication Basics
  - Elements of a Basic Configuration
  - Configuring I/O Points
  - Calibrating AI and AO Points
  - Overview of MVS Products
  - Setup of Multi-dropping of MVS
  - Configuring AGA Flow Calculations
  - Configuring FloBoss History
  - Modbus Tables
  - PID Configuration
  - Building FloBoss Displays
  - FST Workshop

**Audience**

This Remote Automation Solutions course is for engineers, technicians and others involved with the configuration and operation of the FloBoss™ 103 and 107 products.

**Prerequisites**

Participants should have a working knowledge of their application/process and should also have advanced PC knowledge and be thoroughly familiar with Microsoft Windows operating systems (XP or later versions).



### Remote Automation Solutions FloBoss Modbus Configuration for ROC800 & FloBoss - Virtual - RA1250V CEUs - 0.35



#### Overview

This 4-hour Virtual Course will provide an overall working knowledge of configuring the ROC800 and FloBoss™ Series for Modbus communications. Each student will be provided remote access to a PC (ROCLINK preinstalled), and a Remote Automation Solutions RTU device

#### Topics

- Configuration for Modbus Slave
- Configuration for Modbus Master
- Modbus Serial IP
- Basic Modbus Troubleshooting

#### Audience

This course is for engineers, technicians, and others interested in understanding the configuration and operation of the ROC800 using the SmartProcess Oil and Gas Applications

#### Prerequisites

Completed course RA1220 or RA1240 or have sufficient working knowledge of configuring the ROC800 or FloBoss. Basic PC knowledge and familiar with Microsoft Windows operating systems (XP or later version).

### Remote Automation Solutions FB3000 Demo – Introduction – Virtual – RA1160V



#### Overview

This no-cost 2 hour short course utilizes the Virtual Classroom to provide a basic configuration of the FB3000 RTU device.

#### Topics

- How Virtual Learning works
- Basic configuration selections using Field Tools software.

#### Prerequisites

None

### Remote Automation Solutions FB3000 Hardware Configuration - RA620 CEUs – 1.4

#### Overview

This 2-day hands-on course covers the hardware, configuration and maintenance of the FB3000 RTU.

This course will equip you with the necessary knowledge and practice needed to configure the FB3000 hardware for communications and I/O as well as Field Tools Software. Learn how to troubleshoot and utilize software application programs to monitor live data and communication statistics.

#### Topics

##### DAY 1

- Intro to the FB3000
- Hardware Options
- Personality Modules
- Downloading/ Uploading a Configuration
- Saving a Configuration
- Local Serial Communications
- Mini USB Communications
- I/P Communication Setup
- Flashing Firmware
- File Types Used
- Replacing Boards
- Interpreting Status LED's?
- Memory Types Used

##### DAY 2

- Using Field Tools Software
- Replacing Battery on CPU and Power Modules
- Setting up a AGA3 Configuration
- Setting up a AGA7 Configuration
- Configuring for History and Events
- Creating and Saving Configurations
- Cold Start/Warm Start Differences
- Configuring for Alarms
- Basic Troubleshooting Examples
- Using the Guided Setup Wizard
- Intro to Math Blocks
- Calibration

#### Audience

Field personnel whose responsibilities may include:

- Installation
- Wiring, start-up
- Troubleshooting
- Configuration or maintenance of the FB3000 products
- An individual who seeks a more thorough understanding of the FB3000 products

#### Prerequisites

Participants should have formal instrument technician training and a working knowledge of their application/process

- Participants must be thoroughly familiar with Windows10

### Remote Automation Solutions FB3000 Hardware Configuration - RA620V – Virtual - CEUs – 1.4



#### Overview

This 2-day hands-on course covers the hardware, configuration and maintenance of the FB3000 RTU.

This course will equip you with the necessary knowledge and practice needed to configure the FB3000 hardware for communications and I/O as well as Field Tools Software. Learn how to troubleshoot and utilize software application programs to monitor live data and communication statistics.

#### Topics

##### DAY 1

- Intro to the FB3000
- Hardware Options
- Personality Modules
- Downloading/ Uploading a Configuration
- Saving a Configuration
- Local Serial Communications
- Mini USB Communications
- I/P Communication Setup
- Flashing Firmware
- File Types Used
- Replacing Boards
- Interpreting Status LED's?
- Memory Types Used

##### DAY 2

- Using Field Tools Software
- Replacing Battery on CPU and Power Modules
- Setting up a AGA3 Configuration
- Setting up a AGA7 Configuration
- Configuring for History and Events
- Creating and Saving Configurations
- Cold Start/Warm Start Differences
- Configuring for Alarms
- Basic Troubleshooting Examples
- Using the Guided Setup Wizard
- Intro to Math Blocks
- Calibration

#### Audience

Field personnel whose responsibilities may include:

- Installation
- Wiring, start-up
- Troubleshooting
- Configuration or maintenance of the FB3000 products
- An individual who seeks a more thorough understanding of the FB3000 products

#### Prerequisites

Participants should have formal instrument technician training and a working knowledge of their application/process

- Participants must be thoroughly familiar with Windows10

### Remote Automation Solutions FloBoss S600+ Operator - Introduction - RA900 CEUs - 1.8

#### Overview

The 2-day FloBoss™ S600+ Fundamentals course will have participants become familiar with the FloBoss S600+ hardware, the startup menu, fundamental features of the S600+ applications. Be able to operate FloBoss S600+ front panel and web-server. Be able to download and upload configurations. Be able to edit S600+ configuration files using PC Setup, Report Editor, Modbus Editor and Display Editor. The FloBoss S600+ Fundamentals course provides an overview into the hardware and operational aspects of the FloBoss S600+ flow computer.

#### Topics

- Introduction to S600+
- Standard Application Overview
- S600+ Hardware Overview
- Navigating Displays
- Editing Display Items
- Editing Configurations with Config600
- Using Config600 Transfer

#### Prerequisites

Participants should be familiar with metering techniques and standards. Participants should bring their own laptop computers to the course and should preferably have administrator privileges. Participants must be PC literate

### Remote Automation Solutions FloBoss S600+/Config600 - Advanced - RA901 CEUs - 1.8

#### Overview

The 2-1/2-day advanced course provides an insight into the generation of application configurations for the FloBoss™ S600+.

#### Topics

- Loading Config600 Pro Software License
- Firmware Versions
- Using System Editor Object Types
- Logical cEditor
- Registering Tickets - Do's and Don'ts

#### Audience

This FloBoss S600+ Advanced Course is aimed at application engineers and system integrators who design and develop FloBoss S600+ applications for integration with metering systems and skids.

#### Prerequisites

Participants should be familiar with metering techniques and standards. Participants should bring their own personal computer to the course and should have administrative privileges. Participants must be PC literate. Participants must have attended the RA900

### Remote Automation Solutions FloBoss S600+/Config600 - Advanced - Virtual - RA901V CEUs - 1.8

#### Overview

The 2-1/2-day advanced virtual course provides an insight into the generation of application configurations for the FloBoss™ S600+.

#### Topics

- Loading Config600 Pro Software License
- Firmware Versions
- Using System Editor Object Types
- Logical cEditor
- Registering Tickets - Do's and Don'ts

### Remote Automation Solutions FloBoss Troubleshooting Configuration for Gas Measurement - RA1230 CEU'S: 1.8

#### Overview

This 2.5 day course will provide a basic overall working knowledge of the FloBoss 107 Controller. (Contact Educational Services for special discounting when enrolling in both course RA1230 Troubleshooting Configuration and course RA1231 Configurations - Advanced at 1-800-338-8158). Participants are presented with a basic view of the FloBoss 107 hardware and software to obtain the necessary knowledge needed to configure, calibrate, view live data and trouble shoot the FloBoss 107.

#### Topics

##### Day 1

- Introduction and Overview of FloBoss
- FloBoss 107 CPU and I/O Cards
- ROCLINK 800 Configuration Software Overview
- Creating a Connection to the FloBoss 107 Local Operator Interface Port Ethernet Port
- Elements of Basic Configuration
- Configuring from Factory Defaults Reset System in ROC Flags Configure System Information

##### Day 2

- Configuring Communications
- Configuring Field I/O
- Calibrating the AI, AO, and RTD
- Configuring Station and Runs for the AGA3 and AGA7 Flow Calculations
- Configuring Historical Database

##### Day 3

- Alarm and Events Logs
- Saving and Restoring Configurations
- Using the System Utilities
- Troubleshooting

#### Audience

This course is for engineers, technicians, and others involved with the configuration and operation of the FloBoss 107.

### 1230 – Continued...

#### Prerequisites

None

### Remote Automation Solutions FloBoss Troubleshooting Configuration for Gas Measurement – Virtual - RA1230V CEU'S: 1.8

#### Overview

This 2.5 day course will provide a basic overall working knowledge of the FloBoss 107 Controller. (Contact Educational Services for special discounting when enrolling in both course RA1230 Troubleshooting Configuration and course RA1231 Configurations - Advanced at 1-800-338-8158). Participants are presented with a basic view of the FloBoss 107 hardware and software to obtain the necessary knowledge needed to configure, calibrate, view live data and trouble shoot the FloBoss 107.

#### Topics

##### Day 1

- Introduction and Overview of FloBoss
- FloBoss 107 CPU and I/O Cards
- ROCLINK 800 Configuration Software Overview
- Creating a Connection to the FloBoss 107 Local Operator Interface Port Ethernet Port
- Elements of Basic Configuration
- Configuring from Factory Defaults Reset System in ROC Flags Configure System Information

##### Day 2

- Configuring Communications
- Configuring Field I/O
- Calibrating the AI, AO, and RTD
- Configuring Station and Runs for the AGA3 and AGA7 Flow Calculations
- Configuring Historical Database

##### Day 3

- Alarm and Events Logs
- Saving and Restoring Configurations
- Using the System Utilities
- Troubleshooting

### Remote Automation Solutions FloBoss S600+/Config600 - Introduction - Virtual - RA900V CEUs - 1.8



#### Overview

The 2-day FloBoss™ S600+ Fundamentals course will have participants become familiar with the FloBoss S600+ hardware, the startup menu, fundamental features of the S600+ applications. Be able to operate FloBoss S600+ front panel and web-server. Be able to download and upload configurations. Be able to edit S600+ configuration files using PC Setup, Report Editor, Modbus Editor and Display Editor. The FloBoss S600+ Fundamentals course provides an overview into the hardware and operational aspects of the FloBoss S600+ flow computer.

#### Topics

- Introduction to S600+
- Standard Application Overview
- S600+ Hardware Overview
- Navigating Displays
- Editing Display Items
- Editing Configurations with Config600
- Using Config600 Transfer

#### Prerequisites

Participants should be familiar with metering techniques and standards. Participants should bring their own laptop computers to the course and should preferably have administrator privileges. Participants must be PC literate.

### Remote Automation Solutions FloBoss S600+Combined Config600 - RA902 CEUs - 3.2

#### Overview

The 4-1/2-day course will provide participants hardware knowledge of the S600+. How to navigate the keypad display and be able to create and edit S600+ configurations using Config600 software. The FloBoss™ 600+ Combined Course is a combination of both the fundamentals course and the advanced course in one.

#### Topics

- Standard Application Overview S600+
- Hardware Overview Navigating Displays
- Editing Display Items
- Editing Configurations with Config600 Using
- Config600 Transfer
- Loading Config600 Pro Software License
- Firmware Versions
- Using System Editor Object Types
- Logical cEditor
- Registering Tickets - Do's and Don'ts

#### Prerequisites

Participants should be familiar with metering techniques and standards. Participants should bring their own laptop computers to the course and should have administrative privileges. Participants must be PC literate.

### Remote Automation Solutions FloBoss Configuration & Operations - Virtual - RA1220V CEUs - 3.0



#### Overview

This 2-1/2-day virtual course will provide an overall working knowledge of the FloBoss™ 103, FloBoss 107. Participants are presented with a comprehensive view of the FloBoss 103/107 hardware and ROCLINK800 software to obtain the necessary knowledge needed to effectively install, configure and maintain the FloBoss 103/107 products. Each student will be provided access to a PC (ROCLINK800 preinstalled), a FloBoss 107RTU, a communications cable and a workbook for the duration of the class.

#### Topics

- Flow Measurement Review
- FloBoss™ 103/107 Hardware Overview
- FloBoss
  - Check and Set ROC Information
  - Check and Set ROC System Flags
  - Communication Basics
  - Elements of a Basic Configuration
  - Configuring I/O Points
  - Calibrating AI and AO Points
  - Overview of MVS Products
  - Setup of Multi-dropping of MVS
  - Configuring AGA Flow Calculations
  - Configuring FloBoss™ History
  - Modbus Tables
  - PID Configuration
  - Building FloBoss Displays
  - FST Workshop

#### Audience

This Remote Automation Solutions course is for engineers, technicians and others involved with the configuration and operation of the FloBoss™ 103 and FloBoss 107 products.

#### Prerequisites

Participants should have a working knowledge of their application/process and should also have advanced PC knowledge and be thoroughly familiar with Microsoft Windows operating systems (XP or later versions).

### Remote Automation Solutions ControlWave Programming – Introduction - Virtual - RA1140V

CEU – 0.2



#### Overview

This FREE 2-hour short course utilizes the Virtual Classroom to provide basic programming steps in programming the ControlWave device using Ladder Logic and Function Block languages.

#### Topics

- How Virtual Learning works
- Programming in Ladder Logic
- Compiling and downloading application project
- Using Stimulation Mode
- Inserting a Function Block

#### Audience

All personnel interested in a brief overview of programming ControlWave devices.

#### Prerequisites

None

### Remote Automation Solutions FB3000 Programming & Configuration - Advanced - RA630

#### Overview

This 3-day hands-on course covers the Software and Advanced Configuration of the FB3000 RTU.

This course will equip you with the necessary knowledge and practice needed to configure the FB3000 using Field Tools and FBxDesigner . Learn how to troubleshoot and utilize software application programs to monitor live Values.

#### Topics

##### DAY 1

- Intro to the FB3000
- Hardware Options
- Personality Modules
- Downloading/ Uploading a Configuration
- Using Field Tools Software and Menus
- Modbus Communications between FB3000's
- Using the Point Pickers to Configure
- Setting up a Station with Two Runs
- Engineering Units Setup

##### DAY 2

- Setting up the Clock
- PID Configuration
- Using FBxDesigner
- Create a Small Project in FBxDesigner
- Programming Languages Available in FBxDesigner
- Creating a Simple Display
- Setting up a AGA7 Configuration
- Configuring for History and Events
- Creating and Saving Configurations

### RA630-Continued...

#### DAY 3

- Application Management
- Application Information
- Viewing Reports
- Effects Examples
- Math Block Examples
- Device Licenses

#### Audience

Field personnel whose responsibilities may include:

- Installation
- Wiring, start-up
- Troubleshooting
- Configuration or maintenance of the FB3000 products
- An individual who seeks a more thorough understanding of the Programming Capabilities of the FB3000 products

#### Prerequisites

Participants should have formal instrument technician training and a working knowledge of their application/process.

- Participants must be thoroughly familiar with Windows 10.

### Remote Automation Solutions FB3000 Programming & Configuration - Advanced – Virtual - RA630V

#### Overview

This 3-day hands-on course covers the Software and Advanced Configuration of the FB3000 RTU.

This course will equip you with the necessary knowledge and practice needed to configure the FB3000 using Field Tools and FBxDesigner . Learn how to troubleshoot and utilize software application programs to monitor live Values.

#### Topics

##### DAY 1

- Intro to the FB3000
- Hardware Options
- Personality Modules
- Downloading/ Uploading a Configuration
- Using Field Tools Software and Menus
- Modbus Communications between FB3000's
- Using the Point Pickers to Configure
- Setting up a Station with Two Runs
- Engineering Units Setup

##### DAY 2

- Setting up the Clock
- PID Configuration
- Using FBxDesigner
- Create a Small Project in FBxDesigner
- Programming Languages Available in FBxDesigner
- Creating a Simple Display
- Setting up a AGA7 Configuration
- Configuring for History and Events
- Creating and Saving Configurations

##### DAY 3

- Application Management
- Application Information
- Viewing Reports
- Effects Examples
- Math Block Examples
- Device Licenses

#### Audience

### RA630-Continued...

Field personnel whose responsibilities may include:

- Installation
- Wiring, start-up
- Troubleshooting
- Configuration or maintenance of the FB3000 products
- An individual who seeks a more thorough understanding of the Programming Capabilities of the FB3000 products

#### Prerequisites

Participants should have formal instrument technician training and a working knowledge of their application/process.

- Participants must be thoroughly familiar with Windows 10.

### Remote Automation Solutions Marine Terminal Management - Introduction - RA504V

CEU – 1.4



#### Overview

This 2-day virtual course helps participants understand the overall terminal process, the basic Terminal Manager software system, and how it works. Additional topics include understanding the elements a of terminal, Terminal Manager Architectures, system configuration, and more.

#### Topics

##### Day 1

- Discussion of Terminal Manger systems
- Elements of a Terminal
- Applications for Terminal Manager
- What is ISA-95 and how Terminal Manager works
- Terminal Manager Hardware
- Communication Protocols

##### Day 2

- Terminal Manager Architectures
- Software Overview
- Post Installation Setup
- System Setup
- System Configuration

#### Audience

The class is intended for users who have experience with programming and configuration of Remote Automation Solutions RTU's in terminal storage arena.

#### Prerequisites

- Participants must have a strong working knowledge of personal computers and Windows 7 or a later version
- Participants must have a strong working knowledge of their application/process
- Participants should have a strong working knowledge of Remote Automation Solutions RTU's



### Remote Automation Solutions OpenEnterprise SCADA Systems Accelerated V2.8x - RA703 CEU – 3.2

#### Overview

This 4 ½ day course provides an accelerated approach to learning about the OpenEnterprise 2.8x SCADA System. At the conclusion of the class, students will be able to install a very simple OpenEnterprise Server and Workstation, configure communications with Remote Automation Solutions' RTU's, build basic HMI displays, configure trends and alarm windows, collect historical data, perform basic SQL queries, and develop a basic user interface using these products.

#### Topics

- Basic Concepts
- Product Architecture
- Database Explorer
- Database Structure
- Display Building
- Aliasing
- History
- SQL Queries
- OE Desktop
- Alarm Priorities
- Security

#### Audience

The class is intended for users who will install, configure and design a basic OpenEnterprise SCADA system.

#### Prerequisites

- Participants must have a strong working knowledge of personal computers and Windows XP or a later version
- Participants must have a strong working knowledge of their application/process
- Participants should have a strong working knowledge of OpenBSI and ControlWave Designer and ROC Configuration

### Remote Automation Solutions FloBoss S600+ Combined Config600 – Virtual - RA902V CEUs - 3.2



#### Overview

The 4-1/2-day course will provide participants hardware knowledge of the S600+. How to navigate the keypad display and be able to create and edit S600+ configurations using Config600 software. The FloBoss™ 600+ Combined Course is a combination of both the fundamentals course and the advanced course in one.

#### Topics

- Standard Application Overview S600+
- Hardware Overview Navigating Displays
- Editing Display Items
- Editing Configurations with Config600 Using
- Config600 Transfer
- Loading Config600 Pro Software License
- Firmware Versions
- Using System Editor Object Types
- Logical cEditor
- Registering Tickets - Do's and Don'ts

#### Prerequisites

Participants should be familiar with metering techniques and standards. Participants should bring their own laptop computers to the course and should have administrative privileges. Participants must be PC literate.

### Remote Automation Solutions ROCLink Configuration - Introduction - Virtual - RA1141V CEU – 0.2



#### Overview

This FREE 2-hour demo provides a brief overview of the Virtual Classroom. In this demonstration, you will learn what the Virtual Classroom is and how it works. Learn some basics of configuring of the ROC800 or FloBoss.

#### Topics

- What is virtual training
- What is required
- Hands-on exercises
- Basic Configurations of the ROC800 or FloBoss

#### Audience

All personnel whose responsibilities may include: configuring, start-up, troubleshooting, of maintenance of the ROC800 or FloBoss products.

#### Prerequisites

None

### Remote Automation Solutions OpenEnterprise SCADA Systems V3.x - Intermediate - RA802 CEUs - 3.2

#### Overview

This 4 ½ day course will equip the participant to be able to; configure the communications, security, historical, alarming, asset modeling and other major subsystems of an OpenEnterprise and Workstation (version 3.x). Most of the tools within the OpenEnterprise Administrative Tools will be covered during this class.

#### Topics

- Configure Security
- Historical Collections
- Alarming
- Asset Modeling
- Work Flows
- Local Signals and Alarms
- Administrative Tools

#### Audience

The course is intended for users who have experience with programming and configuration of Remote Automation Solutions RTUs.

#### Prerequisites

Participants should have formal RTU configuration training and a working knowledge of their application/process. Participants must be thoroughly familiar with Windows 7. Participants should have advanced PC and networking skills. Participants must have completed course RA801 Basic OpenEnterprise Course version 3.x.



**Remote Automation Solutions  
OpenEnterprise Enhancements for  
SCADA Systems - Ver. 3.x - Virtual -  
RA850V  
CEUs - 1.8**



**Overview**

This 2 ½ day virtual course addresses these new subsystems and improvements which were added to the previous 2.8x OpenEnterprise Server system. These enhancements are on a Windows 7 platform and will enable you to install an OpenEnterprise Server/Workstation and configure and perform various Server/Workstation functions. These functions include the ease of adding devices to the system, configuring database calculations, work flows, asset modeling, communicating to Modbus devices and more.

**Topics**

- Calculations
- Work Flows
- Administrative Tools
- MODBUS Data Collection
- Database Asset Modeling

**Audience**

This class is intended for engineers who have OpenEnterprise systems, version 2.8x transitioning to version 3.x.

**Prerequisite**

Participants should have formal RTU configuration training and a working knowledge of their application/process. Participants must be thoroughly familiar with Windows 7. Participants should have advanced PC and networking skills. Participants must have completed course RA701 Basic and RA702 Intermediate Courses version 2.8x.

**Remote Automation Solutions -  
OpenEnterprise - SCADA Systems -  
Basics Ver. 2.8x - RA701  
CEUs - 3.2**

**Overview**

This 4-1/2-day course provides a very brief introduction to the OpenEnterprise Server, and more detailed coverage of the OpenEnterprise Workstation and OpenEnterprise Reporting packages (version 2.8X). At the conclusion of the class, students will be able to install a very simple OpenEnterprise Server and Workstation; configure communications with ControlWaves RTU's and then begin building HMI displays, trends, alarm windows, and develop a basic user interface using these products.

**Topics**

- Database Explorer and Structure
- Creating Display Objects
- Alarm Windows, Alarm & Event History
- Creating and Configuring Trends
- Data Export
- Creating Reports
- System Troubleshooting

**Audience**

The class is intended for users who have experience with programming and configuration of Remote Automation Solutions RTUs.

**Prerequisites**

Participants must have a strong working knowledge of personal computers and Windows XP or later version. Participants must have a strong working knowledge of their applications/process. Participants should have a strong working knowledge of OpenBSI and ControlWave Designer.

**Remote Automation Solutions -  
OpenEnterprise - SCADA Systems -  
Intermediate Ver. 2.8x - RA702  
CEUs - 3.2**

**Overview**

This 4-1/2-day course will equip you to be able to install an OpenEnterprise Server and Workstation; configure the communications, security, historical, alarming, messaging, and other major subsystems. Most of the tools within the OpenEnterprise toolbox will be covered during this class.

**Topics**

- Learn Advanced Configurations of the OpenEnterprise Systems
- Perform Alarming and Messaging Configurations
- Learn to Configure, Diagnose and Troubleshoot OpenEnterprise Systems
- Creating Calculations from RTU Data

**Audience**

This class is intended for engineers who will be designing and building complete OpenEnterprise systems

**Prerequisites**

Participants should have formal RTU configuration training and a working knowledge of their application/process. Participants must be thoroughly familiar with Windows XP or later versions. Participants should have advanced PC and networking skills. Participants must have completed the Basic OpenEnterprise Class course RA701.

**Remote Automation Solutions  
OpenEnterprise SCADA Systems V3.x -  
Introduction - RA801  
CEUs - 3.2**

**Overview**

This 4-1/2-day course provides a very brief introduction to the OpenEnterprise Server, and more detailed coverage of the OpenEnterprise Workstation and OpenEnterprise Reporting packages (version 3.x). At the conclusion of the class, students will be able to install a simple OE Server and Workstation, configure communications with Remote Automation Solution's RTU's and then begin building HMI displays, trends, alarm windows, and develop a basic user interface using these products.

**Topics**

- Database Structure
- Creating Display Objects
- Alarm Windows, Alarm & Event History
- Creating and Configuring Trends
- Data Export
- Creating Reports
- Calculation Server
- Communications Manager
- Data Collection
- Plant Area Grouping

**Audience**

The class is intended for users who have experience with programming and configuration of Remote Automation Solutions RTUs.

**Prerequisites**

Participants must have a strong working knowledge of personal computers and Windows 7. Participants must have a strong working knowledge of their application/process. Participants should have a strong working knowledge of Remote Automation Solutions RTUs.

**Remote Automation Solutions  
OpenEnterprise SCADA Systems V3.x -  
Virtual – Introduction - RA801V  
CEUs - 3.2**



**Overview**

This 4-1/2-day virtual course provides a very brief introduction to the OpenEnterprise Server, and more detailed coverage of the OpenEnterprise Workstation and OpenEnterprise Reporting packages (version 3.x). At the conclusion of the class, students will be able to install a simple OE Server and Workstation, configure communications with Remote Automation Solution's RTU's and then begin building HMI displays, trends, alarm windows, and develop a basic user interface using these products.

**Topics**

- Database Structure
- Creating Display Objects
- Alarm Windows, Alarm & Event History
- Creating and Configuring Trends
- Data Export
- Creating Reports
- Calculation Server
- Communications Manager
- Data Collection
- Plant Area Grouping

**Audience**

The class is intended for users who are responsible for installing and configuring the Open Enterprise system.

**Prerequisites**

Participants must have a strong working knowledge of personal computers and Windows 7. Participants must have a strong working knowledge of their application/process. Participants should have a strong working knowledge of Remote Automation Solutions RTUs.

**Remote Automation Solutions  
OpenEnterprise SCADA Systems V3.x -  
Virtual - Intermediate - RA802V  
CEUs - 3.2**



**Overview**

This -1/2-day virtual course will equip the participant to be able to; configure the communications, security, historical, alarming, asset modeling and other major subsystems of an OpenEnterprise and Workstation (version 3.x). Most of the tools within the OpenEnterprise Administrative Tools will be covered during this class.

**Topics**

- Configure Security
- Historical Collections
- Alarming
- Asset Modeling
- Work Flows
- Local Signals and Alarms
- Administrative Tools

**Audience**

The course is intended for users who are responsible for installing and configuring the Open Enterprise system.

**Prerequisites**

Participants should have formal RTU configuration training and a working knowledge of their application/process. Participants must be thoroughly familiar with Windows 7. Participants should have advanced PC and networking skills. Participants must have completed course RA801 Basic OpenEnterprise Course version. 3.x.

### Remote Automation Solutions ROC800L Configuration - RA1244 CEUs - 2.1

#### Overview

This 2-1/2-day course will provide an overall working knowledge of the ROC800L. Participants are presented with a comprehensive view of the ROC800L hardware and software to obtain the necessary knowledge and practice needed to install and configure a ROC800L. Participants will know the differences between the ROC809 and ROC800L. Each student will be provided with a PC (ROCLINK preinstalled), a Remote Automation Solutions RTU (ROC800L), a communications cable, and a workbook for the duration of the class. However, participants are encouraged to bring their laptop to class.

#### Topics

- Basic Concepts and Product features
- Install and configure a ROC800L RTU
- Convert ROC800 to RO800L
- Configuring an Application
- Updating Firmware and Software

#### Audience

This Remote Automation Solutions course is for engineers, technicians and others involved with the operation and maintenance of the ROC800L.

#### Prerequisites

Participants should have formal RTU training, preferably with ROC800 series products, ROCLINK800 software and a working knowledge of their application/process. Participants should have advanced PC knowledge and be thoroughly familiar with Microsoft Windows operating systems (XP or later versions).

### Remote Automation Solutions ROC800L Configuration - Virtual - RA1244V CEUs - 2.1



#### Overview

This 2-1/2-day virtual course will provide an overall working knowledge of the ROC800L. Participants are presented with a comprehensive view of the ROC800L hardware and software to obtain the necessary knowledge and practice needed to install and configure a ROC800L. Participants will know the differences between the ROC809 and ROC800L. Each student will be given access to a PC (ROCLINK preinstalled), a Remote Automation Solutions RTU (ROC800L), and a workbook for the duration of the class.

#### Topics

- Basic Concepts and Product features
- Install and configure a ROC800L RTU
- Convert ROC800 to RO800L
- Configuring an Application
- Updating Firmware and Software

#### Audience

This Remote Automation Solutions course is for engineers, technicians and others involved with the operation and maintenance of the ROC800L.

#### Prerequisites

Participants should have formal RTU training, preferably with ROC800 series products, ROCLINK800 software and a working knowledge of their application/process. Participants should have advanced PC knowledge and be thoroughly familiar with Microsoft Windows operating systems (XP or later versions).

### Remote Automation Solutions ROC800 Configuration & Operations - RA1240 CEUs - 3.2

#### Overview

This 4-1/2-day course will provide an overall working knowledge of the ROC800 series RTU. Participants are presented with a comprehensive view of the ROC800 series hardware and ROCLINK800 software to obtain the necessary knowledge needed to effectively install, configure and maintain the ROC800 series products. Each student will be provided with a PC (ROCLINK800 preinstalled), a Remote Automation Solutions RTU, a communications cable and a workbook for the duration of the course. However, participants are encouraged to bring their laptop to class.

#### Topics

- Flow Measurement Review
- ROC800 Series Hardware Overview
- Introduction to ROCLINK800 Software ROC800 Series Configuration
  - Check and Set ROC Information
  - Check and Set ROC System Flags
  - Communication Basics
  - Elements of a Basic Configuration
  - Configuring I/O Points
  - Calibrating AI and AO Points
  - Overview on MVS Product
  - Setup Multi-Dropping of MVS
  - Configuring AGA Flow Calculation
  - Configuring ROC History
  - Modbus Tables
  - PID Configuration
  - Building ROC Displays
  - FST Workshop

#### Audience

This Remote Automation Solutions course is for engineers, technicians, and others involved with the operation and maintenance of the ROC800 Series products.

#### Prerequisites

Participants should have a working knowledge of their application/process and should be thoroughly familiar with Microsoft Windows operations systems (XP or later versions).

### Remote Automation Solutions ROC800 Configuration & Operations - Virtual - RA1240V CEUs - 2.5



#### Overview

This 3-1/2-day virtual course will provide an overall working knowledge of the ROC800 series RTU. Participants are presented with a comprehensive view of the ROC800 series hardware and ROCLINK800 software to obtain the necessary knowledge needed to effectively install, configure and maintain the ROC800 series products. Each student will be provided with a PC (ROCLINK800 preinstalled), a Remote Automation Solutions RTU, a communications cable and a workbook for the duration of the course.

#### Topics

- Flow Measurement Review
- ROC800 Series Hardware Overview
- Introduction to ROCLINK800 Software
  - ROC800 Series Configuration
    - Check and Set ROC Information
  - Check and Set ROC System Flags
  - Communication Basics
  - Elements of a Basic Configuration
    - Configuring I/O Points
    - Calibrating AI and AO Points
    - Overview on MVS Product
    - Setup Multi-Dropping of MVS
    - Configuring AGA Flow Calculations
    - Configuring ROC History
    - Modbus Tables
    - PID Configuration
    - Building ROC Displays
    - FST Workshop

#### Audience

This Remote Automation Solutions course is for engineers, technicians, and others involved with the operation and maintenance of the ROC800 Series products.

#### Prerequisites

Participants should have a working knowledge of their application/process and should be thoroughly familiar with Microsoft Windows operations systems (XP or later versions).

### Remote Automation Solutions ROC800 Series DS800 Programming - RA1241 CEUs - 1.8

#### Overview

This 2-1/2-day course will provide an overall working knowledge of the five different programming languages for the ROC800 series. The course emphasizes hand-on exercises using DS800 Development Suite to program the ROC800 series products. Each participant will be provided a PC (ROCLINK800 & DS800 preinstalled), a Remote Automation Solutions RTU, a communications cable and a workbook for the duration of the course. However, participants are encouraged to bring their laptop to class.

#### Topics

- DS800 Software Overview
  - Sequential Function Chart
  - Ladder Logic of Ladder Diagram
  - Function Block Diagram
  - Structured Text
  - Instruction List
- ROCLINK 800 Software

#### Audience

This Remote Automation Solutions Course is for engineers, technicians, and others involved with configuring the ROC800 products.

#### Prerequisites

Participants should have experience with ROC800 series hardware and ROCLINK800 software. A working knowledge of their application/process and should be thoroughly familiar with Microsoft Windows operating Systems (XP or later versions). Familiarity with IEC-61131 programming languages is not required, since it is covered in this course.

### Remote Automation Solutions ROC800 Series DS800 Programming - Virtual - RA1241V CEUs - 1.8



#### Overview

This 2-1/2-day virtual course will provide an overall working knowledge of the five different programming languages for the ROC800 series. The course emphasizes hand-on exercises using DS800 Development Suite to program the ROC800 series products. Each participant will be provided a PC (ROCLINK800 & DS800 preinstalled), a Remote Automation Solutions RTU, a communications cable and a workbook for the duration of the course. However, participants are encouraged to bring their laptop to class.

#### Topics

- DS800 Software Overview
  - Sequential Function Chart
  - Ladder Logic of Ladder Diagram
  - Function Block Diagram
  - Structured Text
  - Instruction List
- ROCLINK 800 Software

#### Audience

This Remote Automation Solutions Course is for engineers, technicians, and others involved with configuring the ROC800 Series products.

#### Prerequisites

Participants should have experience with ROC800 series hardware and ROCLINK800 software. A working knowledge of their application/process and should be thoroughly familiar with Microsoft Windows operating Systems (XP or later versions). Familiarity with IEC-61131 programming languages is not required, since it is covered in this course.

### Remote Automation Solutions DL800 Preset System Configuration - RA1242 CEUs - 2.1

#### Overview

This 2-1/2-day course will provide an overall working knowledge of the DL8000 Preset System Controller. Participants will be enabled to configure, operate and diagnose the DL8000 Preset System Controller. Each student will be provided with a PC (ROCLINK preinstalled), a Remote Automation Solutions RTU (DL8000), a communications cable, and a workbook for the duration of the class.

#### Topics

- Basic Concepts and Product features of the DL8000
- Set Up Parameters
- Meter Proving
- Hardware diagnostics and Troubleshooting
- DL8000 Configuring Dynamic, Real-Time Display of Flow Parameters
- Configuring for Additive Injection
  - Temperature Compensation
  - Data Logging
  - Communications
- Blending Methods and Flow Sequencing

#### Audience

This Remote Automation Solutions course is for engineers, technicians, and others involved with the operation and maintenance of the DL8000 Preset System Controller product.

#### Prerequisites

Participants should have formal RTU configuration training preferably with ROC800 series hardware and a working knowledge of their application/process. Participants should have advanced PC knowledge and be thoroughly familiar with Microsoft Windows operating systems (2000/XP or later versions).

### Remote Automation Solutions SmartProcess Production Applications- Introduction – Virtual - RA3012V CEUs - 0.5



#### Overview

Production Manager (PM) Series: Overview and Surface Controls Manager for ROC and FloBoss™ Overview. This 1-day virtual training class will provide an overview of the Production Manager Series, the cornerstone of Emerson's SmartProcess Oil and Gas Applications. This class will focus two of applications, Surface Controls Manager and Local Display Manager, utilized in conjunction with the balance of the applications. Some of the configuration activities will include: control logic, maintenance bypassing, and use of accumulators, advanced calculations configuration, user lists, and display navigation.

#### Topics

- Surface Controls Applications
- Local Display Manager

#### Audience

This course is for engineers, technicians, and others interested in understanding the configuration and operation of the ROC800 using the SmartProcess Oil and Gas Applications.

#### Prerequisites

Participants should have a strong working knowledge of personal computers and Windows XP or a later version.

### Remote Automation Solutions SmartProcess Production Applications Foundation Produced Fluids Management – Virtual - RA3013V CEUs - 1.4



#### Overview

Production Manager (PM) Series: Tank Manager and Integrated Loading Interface for ROC and FloBoss™ Overview This 2-day virtual training course will provide a combination of lecture and hands-on configuration activities related to the management of produced liquids from the separator through fiscal custody transfer. Some of the configuration activities will include: allocation measurement tracking, inventory management, LACT and API 18.1 & 18.2 level-based fiscal transfer methods (via truck and pipeline) and production accounting data reporting. As time permits, an overview of Well Test Manager will be covered.

#### Topics

- Tank Manager
- Haul Log/Viewer
- Tanks
- Well Allocation
- Local Display Manager

#### Audience

This course is for engineers, technicians, and others interested in understanding the configuration and operation of the ROC800 using the SmartProcess Oil and Gas Applications.

#### Prerequisites

Participants should have a strong working knowledge of personal computers and Windows XP or a later version. Participants should have completed course Surface Controls Manager RA3012V.



**Remote Automation Solutions  
SmartProcess Production Applications  
Foundation Well Operations &  
Optimization - RA3014V  
CEUs - 1.4**



**Overview**

Production Manager (PM) Series: Well Optimization and Chemical Manager for ROC and FloBoss™ Overview This 2-day virtual training course will provide a combination of lecture and hands-on configuration activities related to production well operations, such as choke control, artificial lift techniques and chemical injection. Some configuration activities include: (1) modification & tuning of plunger and/or gas lift wells, and (2) application of advanced set point techniques and/or inhibit logic for optimized chemical injection. As time permits, an overview of Automated Choke controls will be covered.

**Topics**

- Well Optimization
- Configuration & Operations
- Gas Lifts
- PAGL
- Cycle Logs
- Chemical Manager
- Chemical Configuration
- Injection Point Configuration

**Audience**

Course is for engineers, technicians, and others interested in understanding the configuration and operation of the ROC800 using the SmartProcess Oil & Gas Applications.

**Prerequisites**

Participants should have a strong working knowledge of personal computers and Windows XP or a later version. Participants should have completed course Surface Controls Manager RA3012V.

**Remote Automation Solutions Terminal  
Manager Operations - Introduction –  
Virtual - RA501V  
CEUs: 1.4**

**Overview**

This 2-day virtual course helps participants understand the overall terminal process, the basic Terminal Manager software system, and how it works. Additional topics include understanding the elements a of terminal, Terminal Manager Architectures, system configuration, and more.

**Topics**

Day 1

- Discussion of Terminal Manger systems
- Elements of a Terminal
- Applications for Terminal Manager
- What is ISA-95 and how Terminal Manager works
- Terminal Manager Hardware
- Communication Protocols

Day 2

- Terminal Manager Architectures
- Software Overview
- Post Installation Setup
- System Setup
- System Configuration

**Audience**

The class is intended for users who have experience with programming and configuration of Remote Automation Solutions RTU's in terminal storage arena.

**Prerequisites**

- Participants must have a strong working knowledge of personal computers and Windows 7 or a later version
- Participants must have a strong working knowledge of their application/process
- Participants should have a strong working knowledge of Remote Automation Solutions RTU'S

**Remote Automation Solutions Terminal  
Manager Business Management –  
Intermediate – Virtual - RA502V  
CEUs: 0.7**

**Overview**

This 1-day virtual course helps participants understand the business components of the terminal process. This online customer order management process includes the execution of scheduling, delivery, and receipt of order. Other business entity topics include allocations of accounts, shippers, drivers and clients.

**Topics**

Business Entity Configuration

- Order Management
- Allocations
- Inventory Management

**Audience**

The class is intended for users requiring the understanding of the business components of the terminal process.

**Prerequisites**

- Participants must have completed course RA501 Terminal Manager Basics and Operations
- A strong working knowledge of personal computers and Windows 7 or later
- Participants must have a strong working knowledge of their application/process

**Remote Automation Solutions Terminal Manager Business Management – Advanced- Virtual - RA503V**  
CEUs: 0.7

**Overview**

This 1-day course helps participants understand the advanced business components of the terminal process which includes aspects of invoicing, net receipts and inventory requests.

**Topics**

Net Receipts

- Invoicing
- Terminal Tank Inventory
- Tariff Requests
- Inventory Management
- Product Rebranding

**Audience**

The class is intended for users requiring the understanding of the business components of the terminal process.

**Prerequisites**

- Participants must have completed course RA501 Terminal Manager Basics and Operations and RA502 Terminal Manager Business Management (Limited)
- A strong working knowledge of personal computers and Windows 7 or later
- Participants must have a strong working knowledge of their application/process

**Remote Automation Solutions ROC800 Operations & Configuration - Introduction - RA1260**  
CEUs: 1.4

**Overview**

This 2-day course will provide a basic overall working knowledge of the ROC800 Controller. **(Contact Educational Services for special discounting when enrolling in both course RA1260 Operation and Configurations Basic and course RA1261 Advanced Configurations at 1-800-338-8158).** Participants are presented with a comprehensive view of the ROC800 hardware and software to obtain the necessary knowledge needed to configure, calibrate and view live data. PC's will be provided along with necessary hardware and courseware for the duration of the class but each participant is encouraged to bring their own PC.

**Topics**

Day 1

- Introduction
- Overview of ROC
- Wiring CPU and I/O Cards
- ROCLINK 800 Configuration Software Overview
- Elements of Basic Configuration
- Configuring Field I/O
- Firmware updates
- Configuring from Factory Defaults

Day 2

- Alarm and Events Logs
- Saving and Restoring Configurations
- Configuring Station and Runs for (AGA3 and AGA7) Flow Calculations
- Configuring Communications
- Calibrating the AI and AO module
- Configuring Historical Database

**Audience**

This Remote Automation Solutions course is for engineers, technicians, and others involved with the configuration and operation of the ROC800.

**Prerequisites**

Participants should have a working knowledge of their application/process and should also have advanced PC knowledge and be thoroughly familiar with Microsoft Windows operating systems (XP or later versions).

**Remote Automation Solutions OpenEnterprise SCADA Troubleshooting - Introduction - Virtual - RA803V**  
CEUs: 1.4

**Overview**

This 2-day course provides a common approach to OpenEnterprise SCADA troubleshooting. At the conclusion of the class, students will be equipped with a practical guide to solving basic problems regarding OE Server and Workstation, RTU configurations, communications, alarms and more.

**Topics**

At the conclusion of the class, students will be equipped with a practical guide to solving basic problems regarding OE Server and Workstation, RTU configurations, communications, alarms and more.

Day 1

- Troubleshooting Common Database Problems
- Troubleshooting Common ControlWave Problems
- Communications
- Project / FCP Concerns
- Alarms
- History
- Database Updating
- Troubleshooting Common ROC/FloBoss Problems
- Communications
- TLP Concerns
- Alarms
- History
- Database Updating

Day 2

- Common Troubleshooting Graphworx Display Aids
- Troubleshooting Common License Concerns
- Troubleshooting Common Server/Workstation Problems
- Troubleshooting Basic History Reporting Problems for ROC and CW

**Audience**

The class is intended for users who have experience with OpenEnterprise 3.2.

**Prerequisites**

- Participants must have completed the RA801 OpenEnterprise for SCADA Systems Basics Course
- Participants must have a strong working knowledge of their application/process

**Remote Automation Solutionsra803  
OpenEnterprise SCADA  
Troubleshooting - Advanced - Virtual -  
RA804V  
CEUs: 1.1**



**Overview**

This 1 1/2-day course provides a common approach to OpenEnterprise SCADA advanced troubleshooting. At the conclusion of the class, students will be equipped with a practical guide to solving basic problems regarding OE Server and Workstation, RTU configurations, communications, alarms and more.

**Topics**

**Day 1**

- Troubleshooting Case 1 Archiving
- Troubleshooting Case 2 MODBUS
- Troubleshooting Case 3 Asset Modeling
- Troubleshooting Case 4 Backfilling a Trend
- Troubleshooting Case 5 Alarm Condition
- Database not starting problems

**Audience**

The class is intended for users who have experience with OpenEnterprise 3.2.

**Prerequisites**

- Participants must have completed the RA801 OpenEnterprise for SCADA Systems Basics Course and RA802 OpenEnterprise Intermediate.
- Participants must have a strong working knowledge of their application/process.

**Remote Automation Solutions ROC800  
Troubleshooting & Configurations -  
Advanced - RA1261  
CEUs: 1.8**

**Overview**

This 2 ½ day course will help participants build upon the basic knowledge of configuring the ROC800 device. (**Contact Educational Services for special discounting when enrolling in both course RA1260 Operation and Configurations Basic and course RA1261 Advanced Configurations at 1-800-338-8158**). Participants will learn how to diagnose symptoms and troubleshoot common field problems, create FST's, configure for Modbus communications to third part devices, and more. PC's will be provided along with necessary hardware and courseware for the duration of the course. Each participant is encouraged to bring their own PC.

**Topics**

**Day 1**

- Configuring Station and Runs for (AGA3 and AGA7) Flow Calculations
- Saving and Restoring Configurations
- Configuring Historical Database
- Sampler Odorizer Control
- PID Configuration
- Radio Controls
- Troubleshooting

**Day 2**

- Setting up Modbus Tables
- Wireless HART
- Network Radio Communications
- FST Workshop
- Displays
- Troubleshooting

**Day 3**

- Troubleshooting

**Audience**

This Remote Automation Solutions course is for engineers, technicians, and others involved with the configuration and operation of the ROC800.

**Prerequisites**

Participants should have completed the ROC800 Basic course or have a comparable working knowledge of the ROC800 product. A good understanding of their application/process is helpful along with advanced PC knowledge, thoroughly familiar with Microsoft Windows operating systems (XP or later versions).

**Remote Automation Solutions - ROC800  
Troubleshooting and Configurations -  
Advanced – Custom - RA1261C  
CEUs: 2.1**

**Overview**

This 1 ½ day course will help participants build upon the basic knowledge of configuring the ROC800 device. (Contact Educational Services at 1-800-338-8158 for special discounting when combined with RA1260 Operation and Configurations Basic the discounted price will be \$500). Participants will learn how to diagnose symptoms and troubleshoot common field problems, create FST's, configure for Modbus communications to third part devices, and more. PC's will be provided along with necessary hardware and courseware for the duration of the course. Each participant is encouraged to bring their own PC.

**Topics**

**Day 1**

- Configuring Field I/O (Review)
- Configuring Stations and Runs for (AGA3 and AGA7) Flow Calculations (Review)
- Saving and Restoring Configurations (Review)
- Configuring Historical Database (Review)
- Configuring Control Items
  - Sampler/Odorizer Control
  - Radio Controls
  - Configure PID in Interactive Plant Environment

**Day 2**

- Setting up Modbus Tables
- FST Workshop
- Displays
- Wireless HART to Rosemount Transmitters in IPE
- Network Radio Communications

**Audience**

This Remote Automation Solutions course is for engineers, technicians, and others involved with the configuration and operation of the ROC800.

**Prerequisites**

Participants should have completed the ROC800 Basic course or have a comparable working knowledge of the ROC800 product. A good understanding of their application/process is helpful along with advanced PC knowledge, thoroughly familiar with Microsoft Windows operating systems (XP or later versions).

## Measurement & Analytical



**AMS Device Manager:** 7021, e2300  
**Flame and Gas:** 2349, 2350, 2351, 2354, 2355

**Precision Flow:** 2340, 2340A, 2341, 2341A, C6000, C6001, C6002, C6003, C6004, 2339SM, 2339SV, 2383, 2394, 2384, 2387

**Gas Chromographs:** R4210, R4170, R4213, R4214, R431, R4315, R4316, E4070

**Interactive Plant Environment:** 2800, 2808, 2812, 2821, 2829, 2875, 2850, 2896, 2898, 5705, 5715

**Level:** 2332, 2333, 2334, 2336, 2337, e2330, e2396

**Liquid Analysis:** 2205, 2800, e2601, e2602

**Pressure:** 2305, 2307, 2308, 2309, 2310, 2326, 2329, 2343, 2345, e2309, e2977

**Process Gas Analyzers:** 2110, 2170, 2171, 2156, 2157

**Tank Gauging:** RTG101, RTG102

**Temperature:** 2321, 2326, 2328, 2329

**Wireless:** 2375, 2376, 2875, e2977

**Rosemount - Process Measurement Products (Pressure & Temperature) - I – 2326**

**CEUs - 2.18**

### Overview

This 4-day course explains how pressure and temperature transmitters function and how they are installed and calibrated. It emphasizes installation, proper set-up and calibration of Analog and HART® Pressure and Temperature Transmitters. The course uses lectures and labs to teach the students. Those who complete this class will be able to:

- correctly perform installation and setup procedures
- properly configure transmitters
- properly calibrate transmitters
- perform basic troubleshooting

**Rosemount - Process Measurement Products (Pressure & Temperature) - I – 2326-Continued...**

### Topics

- Basic 4-20 mA Loop Setup
- Pressure Sensors
- Temperature Sensors (TC, RTD)
- Analog Transmitters (1151)
- HART® Communication
- Field Communicator
- Pressure Transmitters
- Temperature Transmitters
- Using AMS Device Manager to Configure and Calibrate Transmitters
- Installation
- Configuration
- Calibration
- Troubleshooting

### Audience

This course is intended for technicians, engineers and other plant personnel who need to know installation, calibration, maintenance and troubleshooting of measurement instrumentation.

### Prerequisites

Some experience in instrument calibration, maintenance, installation and operation would be helpful.

**Rosemount Process Measurement DP Flow Products - 2327**  
**CEUs - 1.4**

### Overview

This 2-day course explains how DP flow instruments function and how they are installed and calibrated. It emphasizes installation, proper setup and calibration/verification of DP flow instruments. The course uses lectures and labs to teach the students. Those who complete this class will be able to:

- correctly install configure, calibrate multivariable DP Flow Transmitters
- perform DP Flow troubleshooting

### Topics

- Basic DP Flow Fundamentals
- DP Flow Sizing Calculations
- Multivariable Flow Transmitters
- AMS Device Manager with Engineering Assistant Snap-ON (3095)
- Engineering Assistant for 3051SMV
- Field Communicator
- Test Equipment Selection
- Installation
- Configuration
- Calibration /Verification
- Troubleshooting DP Flow Installations

**Rosemount Process Measurement DP Flow Products - 2327-Continued...**

### Audience

This course is intended for technicians, engineers and other plant personnel who need to know installation, calibration, verification, maintenance and troubleshooting of DP flow measurement instrumentation.

### Prerequisites

Some experience in instrument calibration/verification, maintenance, installation and operation would be helpful.

**Rosemount - Process Measurement Products (Level) - III – 2333**  
**CEUs - 2.1**

### Overview

This 3-day course explains how level instruments function and how they are installed calibrated/verified. It emphasizes installation, proper setup and calibration/verification of level instruments. The course uses lectures and labs to teach the students. Those who complete this class will be able to:

- correctly install, configure, calibrate/verify, perform maintenance and troubleshooting on the following:
  - DP Level Transmitters
  - Guided Wave Radar Transmitters
  - Non-contacting Radar Transmitters
- Use Radar software for configuration and troubleshooting

### Topics

- DP Level Fundamentals
- Electronic Remote Sensors
- Radar Applications
- Radar Instruments
- Radar PC Software
- Field Communicator
- Test Equipment Selection
- Installation
- Configuration
- Calibration /Verification
- Troubleshooting

### Audience

This course is intended for technicians, engineers and other plant personnel who need to know installation, calibration, maintenance and troubleshooting of level measurement instrumentation.

### Prerequisites

Experience in instrument calibration, maintenance, installation and operation would be helpful.

### Rosemount Fieldbus Measurement Instruments– 2370 CEUs - 2.1

#### Overview

This 3-day class covers the integration of FOUNDATION™ fieldbus compliant measurement devices using the Field Communicator, Emerson USB Fieldbus Modem, AMS Device Manager, and other hosts.

Upon completion of this course students will be able to: install, configure, calibrate, and troubleshoot Rosemount Fieldbus devices which include the 3051C and 3051S Pressure Transmitters, 644, 3144P and 848 Temperature transmitters 5600, 5400 and 5300 Radar Level Transmitters, and 752 Indicator.

#### Topics

- FOUNDATION™ fieldbus Overview
- Fieldbus: Wiring/Segment Design/Function Blocks
- Field Communicator Operation
- AMS Device Manager Operation
- Theory of Operation, Installation, Configuration, Maintenance, Calibration and Troubleshooting on the following:
  - 3051C Pressure Transmitter
  - 3051S Pressure Transmitter
  - 3144P, and 644 Temperature Transmitters
  - 848 Temperature Transmitter
  - 5600, 5400 and 5300 Radar Level Transmitters
  - 752 Fieldbus Indicator

Note: Course may be conducted using other Fieldbus Hosts, such as AMS Device Manager.

#### Audience

This course is for individuals responsible for installing, configuring, calibrating, and troubleshooting FOUNDATION™ fieldbus measurement devices.

#### Prerequisites

Experience in instrument calibration, maintenance, installation, and operation would be helpful.

### Rosemount Process Measurement Instrumentation - Introduction– 2320 CEUs - 2.1

#### Overview

This 3-day course explains the measurement technology for Pressure, Temperature, Flow and Level instruments. It will also emphasize proper installation of these instruments.

#### Topics

- 4-20 mA Electrical Loops
- Pressure Sensors
- Pressure Instruments
- Temperature Sensors
- Temperature Instruments
- Analog Transmitters
- Smart Transmitters
- HART® Communication Protocol
- Field Communicator
- DP Flow
- Flow Technology Overview
- DP Level
- Electronic Remote Sensors
- Guided Wave Radar Level Instruments
- Non-Contacting Radar Level Instruments
- Self-Organizing Wireless Networks

#### Audience

This course is intended for engineers and other persons responsible for the selection and installation of instruments for measurement types of Pressure, Temperature, Level, and Flow.

#### Prerequisites

Students should have experience with process instrumentation and measurements.

### Rosemount Measurement Instrument - Introduction– 2322 CEUs - 1.4

#### Overview

This 2-day course explains the measurement technology for Pressure, Temperature, Flow and Level instruments. It will also emphasize proper installation of these instruments.

#### Topics

- 4-20 mA Electrical loops
- Pressure Sensors
- Pressure Instruments
- Temperature Sensors
- Temperature Instruments
- Analog Transmitters
- HART® Transmitters
- HART Communication Protocol
- Field Communicator
- DP Flow
- Guided Wave Radar Level Instruments

### Rosemount Measurement Instrument - Introduction– 2322 – Continued...

- Non-Contacting Radar Level Instruments

#### Audience

This course is intended for engineers and other persons responsible for the selection and installation of instruments for measurement types of Pressure, Temperature, Level, and Flow.

#### Prerequisites

Students should have experience with process instrumentation and measurements.

### Rosemount Millennium II Gas Detector Transmitter – 2350 CEUs – 0.7

#### Overview

This 1-day course covers Gas Detection measurement principles and theory of operation. The class will discuss the installation, configuration, operation, calibration, maintenance and troubleshooting of the Rosemount Millennium II Gas Detectors.

Upon completion students will know how to properly install, wire, configure, test with appropriate gases, and basic troubleshooting.

### Rosemount Process Measurement Instrumentation – Introduction –Virtual 2320V



#### Overview

This 8-hour course introduces the common technologies, basic components, performance considerations and technology selection for pressure, temperature, level, flow and communication.

#### Topics

- Pressure
- Temperature
- Level
- Flow
- Communication

#### Audience

Instrument Technicians

#### Prerequisites

None



### Rosemount Pressure, Temperature & MultiVariable Flow Transmitters – 2329 CEUs - 1.4

#### Overview

This 2-day course uses lectures and labs to maximize the hands-on experiences and teach the student how to install, configure, calibrate, troubleshoot, and maintain the Rosemount 3051, 3144P, and 3051SMV Transmitters.

#### Topics

- Field Communicator Operation
- 3051 Pressure Transmitter Installation, Configuration, Calibration and Troubleshooting
- 3144P Temperature Transmitter Installation, Configuration, Calibration and Troubleshooting
- 3051SMV Multivariable DP Flow Transmitter Installation, Configuration, Calibration and Troubleshooting

#### Note:

Students must attend both days. Reference course, 2305, 2321 and 2308MV for further details.

#### Prerequisites

Students should have experience with process instrumentation and measurements.

### Rosemount Process for Measurement Technologies – Introduction – c2323

#### Overview

Learn about the basics of process fundamentals across measurement technologies. This curriculum will give an introduction into the following categories: Amperometric, Combustion, Communication Protocols, Conductivity, Flow, Level, pH, Pressure, Temperature.

#### Topic

Establish a basic understanding of available measurement technologies within the process automation industries.

#### Audience

Engineer, technicians, specialists and operators

**Prerequisite** - None

### Rosemount – 975 Flame Detector Transmitter – 2351 CEUs - 0.7

#### Overview

This 1-day course covers Flame Detection measurement principles and theory of operation. The class will discuss the installation, configuration, operation, calibration, maintenance and troubleshooting of the Rosemount 975 Flame Detectors.

#### Topics

- Optical sensors technology: UV, UV/IR, Multi IR
- Fuel types
- System design considerations
- Installation
- Proper wiring: terminals, 4-20mA current output
- Optical path components
- Configuration using: 475 Field Communicator, Winhost software
- Testing with flame simulator
- Optics maintenance

#### Prerequisite

None

### Rosemount 3051 Pressure Transmitter – 2305 CEUs - 0.7

#### Overview

This 1-day course uses lectures and labs to teach the student how to install, configure, calibrate and maintain the Rosemount 3051 Pressure Transmitter. The student will also learn the operation of the Field Communicator. Students will:

- explain the differences between Smart & Analog transmitters
- identify 3051 parts and functionality
- explain the principles of operation of the 3051
- configure, calibrate and test 3051 Smart Pressure Transmitters using the Field Communicator or AMS Device Manager
- properly install/troubleshoot the 3051 Smart transmitter

#### Topics

- Smart and Analog Transmitters
- 3051 Overview and Principles of Operation
- Test Equipment Selection
- Bench Testing the 3051 Smart Transmitter
- Field Communicator Operation
- Digital Trims/Calibration
- Installation and Start-up
- Troubleshooting and Maintenance

Note: This product is also included in the 2-day course 2329

### Rosemount - 3051 Pressure Transmitter – 2305 – Continued...

#### Audience

This course is designed for those individuals responsible for the installation and maintenance of the Rosemount 3051 Pressure Transmitter.

#### Prerequisites

Knowledge of basic pressure fundamentals and pressure instrumentation.

### Rosemount 3051 Fieldbus Pressure Transmitter – 2307 CEUs - 0.7

#### Overview

This 1-day course uses lectures and labs to maximize the hands on experiences and teach the student how to install, configure, calibrate and maintain the Rosemount 3051 Fieldbus Pressure Transmitter. The student will also learn the operation of the Field Communicator. Students who complete this course will be able to:

- identify 3051 parts and functionality
- explain the principles of operation of the 3051
- design and build a Fieldbus segment
- configure, test, and calibrate the 3051 Fieldbus Pressure Transmitters using the Field Communicator or AMS Device Manager
- properly install and troubleshoot the 3051 Fieldbus Transmitter

#### Topics

- 3051 Overview and Principles of Operation
- FOUNDATION™ Fieldbus Overview
- Fieldbus Wiring/Segment Design/Function Blocks
- Test Equipment Selection
- Bench Testing 3051 Fieldbus Transmitter
- Field Communicator Operation
- AMS Device Manager Operation
- Digital Trims/Calibration
- Installation and Start-Up
- Troubleshooting and Maintenance

Note: Product is also part of course 2370.

#### Audience

This course is designed for those individuals responsible for the installation, configuration, calibration and maintenance of the Rosemount 3051 Fieldbus Pressure Transmitter.

#### Prerequisites

Knowledge of basic pressure fundamentals and pressure instrumentation.

### Rosemount 3051S Pressure Transmitter – 2308 CEUs - 0.7

#### Overview

This 1-day course uses lectures and labs to maximize the hands on experiences and teach the student how to install, configure, calibrate, troubleshoot, and maintain the Rosemount 3051S Pressure Transmitter. The student will also learn the operation of the Field Communicator or AMS Device Manager. Students who complete this course will be able to:

- identify 3051S parts and functionality
- explain the principles of operation of the 3051S
- configure and test the 3051S HA
- RT® Pressure Transmitters using the Field Communicator or AMS Device Manager
- properly install, configure, calibrate, and troubleshoot the 3051S HART transmitter

#### Topics

- 3051S Overview/Principles of Operation
- 3051S Installation and Options
- Test Equipment Selection
- Configure and Bench Testing the 3051S HART® Transmitter
- Configure and Test the 3051S Advanced Features:
  - Alarm & Saturation Levels, Alarm Direction, Write Protection
  - Process Alerts, Scaled Variable
- Digital Trims/Calibration
- Troubleshooting and Maintenance

#### Audience

This course is designed for those individuals responsible for the installation, configuration, calibration, troubleshooting, and maintenance of the Rosemount 3051S Pressure Transmitter.

#### Prerequisites

Knowledge of basic pressure fundamentals and pressure instrumentation.

### Rosemount 3051S MultiVariable Mass Flow Transmitter – 2310 CEUs - 0.7

#### Overview

This 1-day course uses lecture and labs to maximize the hands-on experience and teach the student how to install, configure, calibrate and maintain the Rosemount Model 3051SMV HART® Mass Flow Transmitter. Students who complete this course will:

- identify transmitter parts and explain their functionality
- explain the principles of operation of the transmitter
- configure and test using the Field Communicator, AMS Device Manager, and the 3051SMV Engineering Assistant software
- configure the compensated flow parameters using the 3051SMV Engineering Assistant Software
- properly install & troubleshoot the 3051SMV transmitter

#### Topics

- DP Flow Fundamentals
- Overview and Principles of Operation
- Test Equipment Selection
- Temperature Sensor Wiring
- Bench Testing the Smart Transmitters
- 3051SMV Engineering Assistant Software
- Operation of the Field Communicator and AMS Device Manager
- Digital Trims/Calibration
- Installation and Start-Up
- Troubleshooting and Maintenance

Note: This product is also included in course 2327 and 2329.

#### Audience

This course is designed for those individuals responsible for the installation, configuration, calibration and maintenance of the Rosemount 3051S Multi Variable (MV) Transmitter.

#### Prerequisites

Knowledge of basic Pressure, and DP Flow fundamentals and instrumentation.

### Rosemount 3095MV MultiVariable Flow Transmitters – 2343 CEUs - 0.7

#### Overview

This 1-day course uses lecture and labs to teach the student how to install, configure, calibrate and maintain the Rosemount Model 3095MV Smart Transmitters. The student will also learn the operation of the Field Communicator. Students who complete this course will:

- identify transmitter parts and explain their functionality
- explain the principles of operation of the transmitter
- configure and test using the Field Communicator and the 3095MV Engineering Assistant (EA) Snap-On software
- configure the compensated flow parameters using AMS Device Manager with the 3095MV Engineering Assistant (EA) Snap-On Software
- properly install/troubleshoot transmitters

#### Topics

- DP Flow Fundamentals
- Overview and Principles of Operation
- Test Equipment Selection
- Temperature Sensor Wiring
- Bench Testing the Smart Transmitters
- AMS Device Manager with the 3095MV EA Snap-On Software
- Operation of the Field Communicator and AMS Device Manager
- Digital Trims/Calibration
- Installation and Start-Up
- Troubleshooting and Maintenance
- Configure/Wire/Setup the HART® Tri-Loop

Note: This product is also included in course 2327.

#### Audience

This course is designed for those individuals responsible for the installation and maintenance of the Rosemount 3095 Multi Variable (MV) Transmitter.

#### Prerequisites

Knowledge of basic pressure and temperature fundamentals/instrumentation

### Rosemount 4088 MultiVariable Flow Transmitters – 2345 CEUs - 0.7

#### Overview

This 1-day course uses lecture and labs to maximize the hands on experience and teach the student how to install, configure, calibrate, and maintain the Rosemount 4088A MV Modbus Transmitters. The student will learn the operation and interface capabilities of the Rosemount Transmitter Interface Software (RTIS) and the Field Communicator. Students who complete this course will be able to:

- Explain the principles of operation of the transmitter
- Configure and test using the RTIS software and the Field Communicator
- Properly install, calibrate and troubleshoot the Transmitters
- Properly configure the transmitters Modbus parameters

#### Topics

- Flow Fundamentals
  - Overview and Principles of Operation
  - Bench Testing the Modbus Transmitter
  - RTIS Software Operation
  - Sensor Trims
  - Installation and Startup
  - Troubleshooting and Maintenance
- Modbus Configuration

### Rosemount 3144P Temperature Transmitter – 2321 CEUs - 0.7

#### Overview

This 1-day course uses lecture and labs to teach the student how to install, configure, calibrate and maintain the Rosemount 3144P HART® Temperature Transmitters. The student will also learn the operation of the Field Communicator. Students who complete this course will:

- identify 3144P parts and explain their functionality
- explain the principles of operation of the 3144P
- configure, calibrate and test 3144P HART® Temperature Transmitters using the Field Communicator or AMS Device Manager
- properly install and troubleshoot the 3144P Temperature Transmitters

#### Topics

- 3144P Overview and Principles of Operation
- Test Equipment Selection
- Sensor Selection and Wiring
- Bench Testing the 3144P HART® Transmitters
- Smart Transmitters
- Field Communicator Operation
- AMS Device Manager Operation
- Digital Trims/Calibration
- 3144P Dual Sensor Setup
- Configuration
- Installation and Start-Up
- Troubleshooting and Maintenance

Note: This course can also be taught using the Rosemount 644. This product is also included in courses 2326 and 2329.

#### Audience

This course is designed for those individuals responsible for the installation, configuration, calibration and maintenance of the Rosemount 3144P HART® Temperature Transmitters.

#### Prerequisites

Knowledge of basic temperature fundamentals and temperature instrumentation.

### Rosemount 3144P Fieldbus Temperature Transmitters – 2324 CEUs - 0.7

#### Overview

This 1-day course uses lecture and labs to maximize the hands on experiences and teach the student how to install, configure, calibrate, troubleshoot, and maintain the Rosemount 3144P Fieldbus Temperature Transmitters. The student will also learn the operation of the Field Communicator. Students who complete this course will be able to:

- identify 3144P parts and explain their functionality
- explain principles of operation of the 3144P
- design and build a Fieldbus segment
- configure, calibrate, and test 3144P Fieldbus Temperature transmitters using the Field Communicator
- properly install and troubleshoot the 3144P Fieldbus Transmitters

#### Topics

- 3144P Overview and Principles of Operation
- FOUNDATION™ fieldbus Overview
- Fieldbus Wiring
- Fieldbus Segment Design
- Fieldbus Function Blocks
- Test Equipment Selection
- Sensor Selection and Wiring
- Bench Testing 3144P Fieldbus Transmitters
- Field Communicator Operation
- Digital Trims/Calibration
- Installation and Start-Up
- Troubleshooting and Maintenance

Note: This product is also part of 2370 course.

#### Audience

This course is designed for those individuals responsible for the installation and maintenance of the Rosemount Model 3144P Fieldbus Temperature Transmitters.

#### Prerequisites

Knowledge of basic temperature fundamentals and temperature instrumentation.

### Rosemount 848 Fieldbus Temperature Transmitters – 2328 CEUs - 0.7

#### Overview

This 1-day course uses lectures and labs to maximize the hands-on experiences and teach the student how to install, configure, troubleshoot, and maintain the Rosemount 848T Fieldbus Temperature Transmitters. The student will also learn the operation of the Field Communicator. Students who complete this course will be able to:

- explain the principles of operation of the 848T
- configure, calibrate, and test the 848T Fieldbus temperature transmitter using the Field Communicator
- design and build a Fieldbus segment
- properly install and troubleshoot the 848T Fieldbus Transmitter

#### Topics

- 848T Overview and Principles of Operation
- FOUNDATION™ fieldbus Overview
- Fieldbus Wiring
- Fieldbus Segment Design
- Fieldbus Function Blocks (including the MAI, and ISEL Blocks)
- Test Equipment Selection
- Sensor Selection and Wiring
- Bench Testing the 848T Fieldbus Transmitters
- Field Communicator Operation
- Digital Trims/Calibration
- Installation and Start-Up
- Troubleshooting and Maintenance

Note: This product is also included in the 3-day 2370 Fieldbus Course.

#### Audience

This course is designed for those individuals responsible for the installation and maintenance of the Rosemount Model 848 Fieldbus Temperature Transmitters

#### Prerequisites

Knowledge of basic temperature fundamentals and temperature instrumentation.

### Rosemount DP Level & Electronic Remote Sensor (ERS) System – 2309 CEUs - 0.7

#### Overview

This 1-day course uses lecture and labs to maximize the hands-on experience and teach the student how to install, configure, calibrate, maintain, and troubleshoot the Rosemount 3051S ERS System. Students who complete this course will:

- identify transmitter parts and explain their functionality
- identify 3051S ERS Hi & Lo sensors
- explain the principles of operation of the ERS System
- configure and test the ERS system using AMS Device Manager and the Field Communicator
- perform zero trims and calibrate the ERS Sensors
- properly install & troubleshoot the 3051S ERS System

#### Topics

- DP Level Technology
- ERS Technology
- ERS Overview and Principles of Operation
- ERS / DP Level Installation
- ERS Wiring
- ERS Configuration with AMS Device Manager and the Field Communicator
- ERS Module Assignments
- ERS Scaled Variable
- Bench Testing the ERS System
- ERS Zero Trims and Calibration
- Troubleshooting and Maintenance

Note: This product is also included in course 2333.

#### Audience

This course is designed for those individuals responsible for the installation, configuration, calibration, troubleshooting and maintenance of the Rosemount 3051S Electronic Remote Sensors (ERS) System.

#### Prerequisites

Knowledge of basic Pressure, and DP Level fundamentals and instrumentation.

### Rosemount DP Level & Remote Diaphragm Seal Systems – e2309

#### Overview

This technical education course covers basic theory of pressure-based level measurement (DP Level) and builds to provide in-depth, technical information on how to specify, install, and maintain remote diaphragm Systems. Target students are individuals responsible for the specification, installation, configuration, and/or maintenance of pressure-based level measurement instrumentation including remote diaphragm seals and Electronic Remote Sensors (ERS™) Technology.

#### Topics

- Learn how pressure-based level systems work including wet/dry legs, remote seals, level transmitters, and Rosemount 3051S Electronic Remote Sensors (ERS™) Technology
- Specify a Rosemount 1199 remote diaphragm seal, Level Transmitter, and 3051S ERS™ model number
- Discuss the application factors and product selections that effect system performance
- Install and configure both a remote seal and an entire pressure-based level system
- Perform common maintenance and troubleshooting techniques on installed remote diaphragm seal and ERS™ System

#### Prerequisites

None

### Rosemount 3300 Guided Wave Radar Level Transmitter - 2332 CEUs - 07

#### Overview

This 1-day course uses lecture and labs to maximize the hands on experience and teach the student how to install, configure, calibrate, troubleshoot and maintain the Rosemount 3300 GWR Level & Interface Transmitters. Students who complete this course will be able to:

- explain the principles of operation of the 3300 GWR
- identify 3300 parts and explain their functionality
- understand the available probe options and when each should be used
- properly install the 3300 GWR
- configure and test the 3300 GWR
- properly troubleshoot the 3300 GWR transmitter using RCT software

#### Topics

- 3300 Overview/Principles of Operation
- Installation of the 3300 GWR
- Configuration of the 3300 GWR
- Bench Testing the 3300 GWR
- Field Communicator Operation
- AMS Device Manager Operation
- Radar Configuration Tools (RCT) Software Operation
- Calibration, Verification and Adjustments
- Troubleshooting and Maintenance
- Troubleshooting and Reading Tank Graphs Using RCT Software

Note: 3300 GWR is also included in the 3-day Level course #2333

#### Audience

This course is for those individuals responsible for the installation, configuration, verification and maintenance of the Rosemount 3300 Series Guided Wave Radar (GWR) Level Interface Transmitters.

#### Prerequisites

Knowledge of basic level and interface fundamentals and instrumentation.

### Rosemount 5300 Guided Wave Radar Level Transmitter – 2337

#### Overview

This 1-day course uses lecture and labs to maximize the hands-on experience and teach the student how to install, configure, troubleshoot and maintain the Rosemount 5300 High Performance GWR Transmitters. Students who complete this course will be able to:

- explain the principles of operation of the 5300 GWR
- identify 5300 GWR parts and explain their functionality
- understand the available probe options and when each should be used
- Properly install and wire the 5300 GWR
- configure and test the 5300 GWR
- understand how to setup the 5300 GWR to work in different applications
- properly troubleshoot the 5300 GWR Transmitter and Installation using Radar Master software

#### Topics

- 5300 Overview and Principles of Operation
- Installation of the 5300 GWR
- Wiring the 5300 GWR
- Configuration of the 5300 GWR
- Bench Testing the 5300 GWR
- Field Communicator Operation
- AMS Device Manager Operation
- Radar Master Software Operation
- Troubleshooting and Maintenance
- Tank & Application Troubleshooting and Echo Handling Using Radar Master Software

Note: 5300 GWR HART® Level transmitter is also included in the 3-day Level course 2333.

#### Audience

This course is designed for those individuals responsible for the installation, configuration, calibration and maintenance of the Rosemount 5300 High Performance Guided Wave Radar (GWR) Series HART® Radar Level Transmitter.

#### Prerequisites

Knowledge of basic level fundamentals and instrumentation.

### Rosemount 5600 Non-Contacting Radar Level Transmitter – 2334 CEUs - 0.7

#### Overview

This 1-day course uses lecture and labs to maximize the hands on experience and teach the student how to install, configure, troubleshoot and maintain the Rosemount 5600 Series HART® Radar Level Transmitters. Students who complete this course will be able to:

- explain the principles of operation of the 5600 Radar
- identify 5600 Radar parts and explain their functionality
- properly install and wire the 5600 Radar
- configure and test the 5600 Radar
- understand how to setup the 5600 Radar to work in different applications
- properly troubleshoot the 5600 Radar Transmitter using Radar Master software

#### Topics

- 5600 Overview and Principles of Operation
- Installation of the 5600 Radar
- Wiring the 5600 Radar
- Configuration of the 5600 Radar
- Bench Testing the 5600 Radar
- 2210 LOI / Display Operation
- Field Communicator Operation
- AMS Device Manager Operation
- Radar Master Software Operation
- Troubleshooting and Maintenance
- Tank and Application Troubleshooting and Echo Handling using Radar Master Software

Note: This product is also included in the 3-day Level course 2333.

#### Audience

This course is designed for those individuals responsible for the installation, configuration, calibration and maintenance of the Rosemount 5600 Series HART® Radar Level Transmitter.

#### Prerequisites

Knowledge of basic level fundamentals and instrumentation.



**Rosemount 5400 Non-Contacting Radar Level Transmitter – 2336**  
CEUs - 0.7

**Overview**

This 1-day course uses lecture and labs to maximize the hands-on experience and teach the student how to install, configure, troubleshoot and maintain the Rosemount 5400 Radar Transmitters. Students who complete this course will be able to:

- explain the principles of operation of the 5400 Radar
- identify 5400 Radar parts and explain their functionality
- properly install and wire the 5400 Radar
- configure and test the 5400 Radar
- understand how to setup the 5400 Radar to work in different applications
- properly troubleshoot the 5400 Radar Transmitter and the installation using Radar Master software

**Topics**

- 5400 Overview and Principles of Operation
- Installation of the 5400 Radar
- Wiring the 5400 Radar
- Configuration of the 5400 Radar
- Bench Testing the 5400 Radar
- Field Communicator Operation
- Radar Master Software Operation
- Troubleshooting and Maintenance
- Tank and Application Troubleshooting and Echo Handling using Radar Master Software

Note: This product is also included in the 3-day Level course 2333.

**Audience**

This course is designed for those individuals responsible for the installation, configuration, calibration and maintenance of the Rosemount 5400 HART® Radar Level Transmitter.

**Prerequisites**

Knowledge of basic level fundamentals and instrumentation.

**Rosemount Wireless Pressure Gauge - e2977**  
CEUs - 0.3



**Overview**

The Wireless Pressure Gauge on-demand course offers a comprehensive set of "How to" lessons designed to bring an interactive learning environment over the internet directly to you at any time. By the end of the course, you will know how to specify, install, configure, maintain, and troubleshoot the gauge. In addition, the course provides learning to maximize the use of the Wireless Pressure Gauge's new capabilities.

**Rosemount 5408 Non-Contacting Radar Level – e2396**  
CEU – 0.2



**Overview**

This two-hour eLearning course will teach the student how to: install, configure, calibrate, maintain, and troubleshoot the Rosemount 5408 Non-Contacting Radar Level transmitter.

**Rosemount – Level Detector – 2140 – e2330**  
CEU – 0.2



**Overview**

This 2-hour eLearning course will teach students how to: install, configure, calibrate, maintain and troubleshoot the Rosemount 2140 Level Detector.

**Topics**

- How it works
- Configuration
- Maintenance procedure
- Troubleshooting the device

**Audience**

Maintenance, engineers, I&E techs, reliability engineering

**Rosemount 8700 Series Magnetic Flowmeter, Interactive Plant Environment – 5715**  
CEU – 0.7

**Overview**

This one-day course consists of a blend of lectures and hands-on exercises that cover the installation, configuration, calibration checks and troubleshooting of the Rosemount 8700 Series Magnetic Flowmeter Systems composed of the Model 8712 and 8732 Transmitters as well as the 8705 Flanged and 8711 Wafer Sensors. The students will learn the operation and capabilities of the Local Operator Interface, and how to use these tools to perform configuration. Common issues encountered and troubleshooting techniques will also be covered. This course includes hands-on exercises within the Inter Active Plant Environment training facility. Customer exclusive classes can be customized to address specific transmitter and configuration tools specific to that customer.

**Audience**

This one-day course is intended for anyone that is involved with properly installing, wiring, configuring and troubleshooting a Rosemount 8700 Series Smart Magnetic flowmeter. Typical job functions include; maintenance technicians, instrument technicians and instrumentation engineers.

**Prerequisites**

None required. However, a basic understanding of the fundamentals of flow measurement, electricity, analog & frequency signal processing are assumed

**Rosemount 8800 Series Smart Vortex Flowmeter, Interactive Plant Environment – 5716**  
CEU – 0.7

**Overview**

This one-day course consists of a blend of lectures and hands-on exercises that cover how to install, configure and maintain the Rosemount 8800 Series Smart Vortex flowmeter systems. Students will learn the operation and Local Operator Interface as well as how to use these tools to perform configuration. Common issues encountered and troubleshooting techniques will also be covered. This course includes hands-on exercises within the Inter Active Plant Environment training facility. Customer exclusive classes can be customized to address specific transmitter and configuration tools specific to that customer

**Audience**

This one-day course is intended for anyone that is involved with properly installing, wiring, configuring and troubleshooting a Rosemount 8800 Series Smart Vortex flowmeter. Typical job functions include: maintenance technicians, instrument technicians and instrumentation engineers.

**Prerequisites**

None required. However, a basic understanding of the fundamentals of flow measurement, electricity, analog & frequency signal processing are assumed.

### Rosemount Wireless Self Organizing Network with Host Integration – 2375 CEUs - 1.4

#### Overview

This 2-day course explains how Self Organizing Wireless Networks function and how they are installed, setup, configured and integrated. It emphasizes planning, proper installation and startup, configuration, maintenance, and integration. The course uses lectures and labs to maximize the hands on experience and teach the students. Students who complete this course will:

- correctly install and setup the 1420 & 1410 Wireless Gateway
- properly install and configure Wireless Transmitters
- properly integrate Host interfaces to the Wireless Gateway

#### Topics

- How Self Organizing Networks Function
- Self Organizing Networks Best Practices
- Network Components
- 1420 & 1410 Installation and Setup
- Network Parameters
- Wireless Transmitters Installation, Configuration, Maintenance and Calibration
- THUM Installation, Wiring and Configuration
- Integrating and Operating AMS Device Manager with the 1420 Wireless Gateway
- Operation of AMS Wireless SNAP-ON
- Modbus Serial Integration
- Modbus TCP Integration
- OPC Integration

#### Audience

This course is intended for technicians, engineers and other plant personnel who need to know how to design, install, setup, configure, maintain and troubleshoot Wireless Self Organizing Networks and their components.

#### Prerequisites

Some experience in Wireless Networks and Host integration would be helpful.

### Rosemount Wireless Self Organizing Network – 2376 CEUs - 0.7

#### Overview

This 1-day course explains how Self Organizing Wireless Networks function and how they are installed, setup, and configured. It emphasizes planning, proper installation and startup, configuration and maintenance. The course uses lectures and labs to maximize the hands on experience and teach the students.

Students who complete this course will:

- correctly install and setup the 1420 & 1410 Wireless Gateway
- properly install and configure Wireless Transmitters

#### Topics

- How Self Organizing Networks Function
- Self Organizing Networks Best Practices
- Network Components
- 1420 & 1410 Installation and Setup
- Network Parameters
- Wireless Transmitters Installation, Configuration, Maintenance and Calibration
- THUM Installation, Wiring, Configuration
- Integrating and Operating AMS Device Manager with the 1420 & 1410 Wireless Gateway and Wireless Devices

#### Audience

This course is intended for technicians, engineers and other plant personnel who need to know how to install, setup, configure, maintain and troubleshoot Wireless Self Organizing Networks and their components.

#### Prerequisites

Some experience in Wireless Networks and Host integration would be helpful. Completion of the Wireless classes on Plantweb University would be beneficial.

### AMS - AMS Device Manager – 7020 CEUs - 2.1

#### Overview

Completing 3-days of AMS Device Manager hands-on instructor assisted training modules and exercises, provides the quickest route to your productive use of this predictive maintenance application.

#### Topics

- Viewing and Modifying Devices
- Creating a Plant Database Hierarchy and Adding Devices
- Using the Field Communicator with AMS Device Manager
- Using the AMS Device Manager Browser Functions
- Audit Trail
- Calibrating Device - Calibration Assistant
- Configuring and Monitoring System Alerts
- Installing an AMS Device Manager Server Plus Standalone
- Starting AMS Device Manager for the First Time
- Network Communication Interface Setup
- AMS Device Manager Database Management
- Installing a Distributed System
- Installing Device Types from Media
- MV Engineering Assistant SNAP-ON Application
- QuickCheck™ SNAP-ON Application
- AMS Device Manager OPC Server and the Matrikon OPC Explorer
- AMS Device Manager Web Services
- AlertTrack™ SNAP-ON Application
- Wireless SNAP-ON Application

#### Audience

This course is intended for technicians and engineers who need to configure and use AMS Device Manager.

### AMS - AMS Device Manager w/Rosemount HART® Instruments – 7021

#### CEUs - 2.1

##### Overview

Learn the installation, calibration, maintenance, and troubleshooting of measurement instrumentation using AMS Device Manager. This 3-day course teaches maintenance and calibration of measurement devices using AMS Device Manager software to communicate and track information. The student will learn how pressure and temperature transmitters function, are installed, and calibrated using AMS Device Manager. The course uses hands-on training, labs, and lecture to teach the student how to:

- configure and use AMS Device Manager correctly perform transmitter installation and setup procedures
- properly configure HART® transmitters
- properly calibrate transmitters
- perform basic troubleshooting-transmitters

##### Topics

- Configuring and Using AMS Device Manager
- Viewing and Modifying Devices
- Creating a Plant Database Hierarchy and Adding Devices
- AMS Device Manager Browser Functions
- Audit Trail
- HART® Communication
- HART Transmitters (3051C, 3144P)
- Test Equipment Selection
- Transmitter Installation and Configuration
- Transmitter Calibration
- AMS Calibration Assistant
- Intelligent Calibrators
- Transmitter Troubleshooting

##### Audience

The hands-on focus is on skills required by engineers, technicians, or others that are new to the plant or instrument environment.

### Rosemount - AMS Trex Device Communicator - e2300

#### CEUs – 0.1

##### Overview



E2300 AMS Trex Device Communicator is an introductory course with lessons on theory of operation, model number and spare part selection, communicator configuration, connecting, communicating, and/or powering HART®, FOUNDATION™ Fieldbus, and wireless devices and positioners, unit maintenance, and troubleshooting the unit and device connectivity.

### Rosemount Pressure Transmitters, Interactive Plant Environment – 2808

#### CEUs - 1.4

##### Overview

This 2-day course combines lectures with bench-top labs and uses the interactive plant for scenario based training. Target students are individuals responsible for the installation, configuration, calibration and maintenance of the Rosemount Pressure transmitters. Students shall apply classroom knowledge directly to the interactive plant scenario labs. Be ready to learn in a "real world" plant environment.

##### Topics

- Identify Transmitter Parts and Functionality
- Explain the Principles of Operation of Pressure Transmitters
- Configure, Calibrate and Test Pressure Transmitters using the Field Communicator
- Properly Install and Troubleshoot Pressure Transmitters
- Students shall ensure proper PPE and safety measures while working on the plant.

### Rosemount Temperature Transmitters, Interactive Plant Environment – 2821

#### CEUs - 0.7

##### Overview

This 1-day course combines lectures with bench-top labs and uses the interactive plant for scenario based training. Students shall apply classroom knowledge directly to the interactive plant scenario labs. Be ready to learn in a "real world" plant environment.

##### Topics

- Identify Transmitter Parts and Functionality
- Explain the Principles of Operation of Temperature Transmitters
- Configure, Calibrate and Test Temperature Transmitters using the Field Communicator
- Properly Install and Troubleshoot Temperature Transmitters.
- Students shall ensure proper PPE and safety measures while working on the plant.

##### Audience

Target students are individuals responsible for the installation, configuration, calibration and maintenance of the Rosemount Temperature transmitters.

### Rosemount 3051 Pressure & 3144P Temperature Transmitters, Interactive Plant Environment – 2898

#### CEUs - 2.1

##### Overview

This 3-day course combines lectures with bench-top labs and uses the interactive plant for scenario based training. Target students are individuals responsible for the installation, configuration, calibration and maintenance of the Rosemount Pressure and Temperature transmitters. Students shall apply classroom knowledge directly to the interactive plant scenario labs. Be ready to learn in a "real world" plant environment.

##### Topics

- Explain the Difference between HART® & Analog Transmitters
- Identify Transmitter Parts and Functionality
- Explain the Principles of Operation of Pressure and Temperature Transmitters
- Configure, Calibrate and Test Pressure and Temperature Transmitters using the Field Communicator
- Properly Install and Troubleshoot Pressure and Temperature Transmitters.
- Students shall ensure proper PPE and safety measures while working on the plant.

### Rosemount – Interactive Plant Environment - Wireless Corrosion & Erosion Monitoring – 2876

#### CEUs – 1.4

##### Overview

This 2-day course explains how corrosion & erosion products work, how they are installed, and commissioned. The course will explain how to properly use the software applications specific to these products as well as integrating with Wireless Self Organizing network functions. The course will explain best practices and troubleshooting the following Rosemount ET310, ET410, ET210, and WT210 corrosion and erosion monitoring systems. The course uses lectures and hands-on IPE labs to maximize the experience and help mentor the students.

##### Topics

- Corrosion & Erosion technology
- Monitoring systems technology and overview
- Wireless technology
- Software operations
- Sensor installation
- Gateway installation
- Network components and parameters
- Troubleshooting
- Database backups
- System logs
- Sensor faults

**Rosemount Pressure, Temperature, MultiVariable Flow Transmitters, Interactive Plant Environment – 2829 CEUs - 2.8**

**Overview**

This 4-day course combines lectures with bench-top labs and uses the interactive plant for scenario-based training. Target students are individuals responsible for the installation, configuration, calibration and maintenance of the Rosemount Pressure, Temperature, and Multi-Variable Flow transmitters. Students shall apply classroom knowledge directly to the interactive plant scenario labs. Be ready to learn in a "real world" plant environment.

**Topics**

- identify transmitter parts and functionality
- explain the principles of operation of the transmitters
- configure, calibrate and test transmitters using the field
- communicator, AMS Device Manager, and Engineering Assistant software
- configure the compensated flow parameters
- properly install and troubleshoot pressure, temperatures and multi-variable flow transmitters

**Audience**

Target students are individuals responsible for the installation, configuration, calibration and maintenance of the Rosemount Pressure, Temperature, and Multi-Variable Flow transmitters.

**Rosemount Guided Wave & Non-Contacting Radar Level Transmitters, Interactive Plant Environment – 2896 CEUs - 1.4**

**Overview**

This 2-day course combines lectures with bench-top labs and uses the interactive plant for scenario-based training. Students shall apply classroom knowledge directly to the interactive plant scenario labs. Be ready to learn in a "real world" plant environment.

**Topics**

- Identify Transmitter Parts and Functionality
- Explain the Principles of Operation the Transmitters
- Configure, Calibrate/Verify and Test Radar Level Transmitters using the Field Communicator, Radar Master Software
- Understand How to Setup the Radars in Different Applications
- Properly Install and Troubleshoot the 5300 & 5400 Transmitters and their Applications

Students shall ensure proper PPE and safety measures while working on the plant.

**Audience**

Target students are individuals responsible for the installation, configuration, calibration and maintenance of the Rosemount 5300 & 5400 Radar Level transmitters.

**Rosemount MultiVariable Flow Transmitter, Interactive Plant Environment – 2812 CEUs - 1.1**

**Overview**

This 1-1/2-day course combines lectures with bench-top labs and uses the interactive plant for scenario-based training. Students shall apply classroom knowledge directly to the interactive plant scenario labs. Be ready to learn in a "real world" plant environment.

**Topics**

- Identify Transmitter Parts and Functionality
- Explain the Principles of Operation of the Transmitters
- Configure, Calibrate and Test Transmitters using the Field Communicator, AMS Device Manager, and Engineering Assistant Software
- Configure the Compensated Flow Parameters
- Properly Install and Troubleshoot Pressure, Temperatures and Multi-Variable Flow Transmitters
- Students shall ensure proper PPE and safety measures while working on the plant.

**Audience**

Target students are individuals responsible for the installation, configuration, calibration and maintenance of the Rosemount 3051SMV Multi-Variable Flow transmitters.

**Rosemount Wireless Self Organizing Networks, Interactive Plant Environment – 2875**

**CEUs: 2.5**

**Overview**

This 3.5-day course combines classroom theory with hands-on labs. Learn by doing with the Interactive Plant Environment. This unique training setting provides a safe and realistic environment to elevate skills and knowledge through direct interaction with live wireless networks and devices. This course is designed for engineers and technicians whose responsibilities include: startup, configuration, troubleshooting, and host integration of wireless networks and devices. Be ready to learn in a "real world" plant environment.

**Topics**

After completing this course, you will be able to:

- Perform a wireless network planning walkthrough
- Know and operate wireless network planning tools
- Install a wireless network following wireless best practices
- Installation and configuration of wireless devices
- Installation and configuration of THUMs
- Troubleshoot Wireless networks, performance and connectivity
- Connect and prove proper MOBUS communications
- Connect and prove proper OPC communications

**Audience**

Engineers and Instrument Technicians

**Prerequisites**

Some experience in Wireless Networks and Host integration would be helpful, but not required. Some basic instrument knowledge would be beneficial.

### Rosemount 8700 Smart Magnetic & 8800 Smart Vortex Flowmeters - Introduction – 2394

CEUs - 0.7

#### Overview

This 1-day course is an abbreviated version of the 2340 and 2341 courses for Rosemount 8700 Series Magnetic and 8800 Series Vortex meters. Typically, 2/3 of the course time is spent on Rosemount's 8800 Vortex flowmeter and 1/3 on Rosemount's 8700 Magnetic Flowmeter. Theory of operation, meter components and installation of each flowmeter are covered. The focus of the class is to provide a hands-on experience configuring and reviewing the most common troubleshooting issue and best practices for resolution.

#### Topics

- After attending the course the student will be able to do the following for both the Rosemount Magnetic and Vortex flowmeters:
- Briefly Explain the Fundamentals for How Each Flowmeter Works and the Function of the Key Components
- Have a Basic Understanding of the Installation Best Practices for Orienting, Mounting and Wiring the Sensor and Transmitter
- Perform a Basic Configuration of the Metering System for Various Applications
- Diagnose and Know How to Correct the Most Common Meter and Process Issues

#### Audience

This combined class is intended anyone that is involved with properly configuring and troubleshooting a Rosemount 8700 Smart Magnetic & 8800 Smart Vortex Flowmeters. Typical job functions include; maintenance technicians, instrument technicians and instrumentation engineers.

#### Prerequisites

This being a 1-Day class covering two flowmeters, some prior experience working with Rosemount's Magnetic and Vortex flowmeters is recommended. However, students with no past experience can also benefit if their learning objectives are to get a basic introduction to operation, installation, configuration and troubleshooting. For all attendees, it is assumed they have a basic understanding of the fundamentals of flow measurement, electricity, analog & frequency signal processing

### Rosemount 8700 Smart Magnetic & 8800 Smart Vortex Flowmeters - Introduction – Virtual – 2394V

CEUs - 0.7



#### Overview

This 1-day course is an abbreviated version of the 2340 and 2341 courses for Rosemount 8700 Series Magnetic and 8800 Series Vortex meters. Typically, 2/3 of the course time is spent on Rosemount's 8800 Vortex flowmeter and 1/3 on Rosemount's 8700 Magnetic Flowmeter. Theory of operation, meter components and installation of each flowmeter are covered. The focus of the class is to provide a hands-on experience configuring and reviewing the most common troubleshooting issue and best practices for resolution.

#### Topics

- After attending the course the student will be able to do the following for both the Rosemount Magnetic and Vortex flowmeters:
- Briefly Explain the Fundamentals for How Each Flowmeter Works and the Function of the Key Components
- Have a Basic Understanding of the Installation Best Practices for Orienting, Mounting and Wiring the Sensor and Transmitter
- Perform a Basic Configuration of the Metering System for Various Applications
- Diagnose and Know How to Correct the Most Common Meter and Process Issues

### Rosemount Troubleshooting: Pressure, Temperature, MultiVariable, & Process Level, Interactive Plant Environment – 2850

#### Overview

This 3-day course utilizes the Interactive Plant Environment's live process to provide students with troubleshooting scenarios focused on Rosemount products. Students will be tasked with real world issues which require critical thinking to properly identify the problem, and then repair, or propose a new solution. Labs will include, but are not limited to: installation, 4-20 mA loop complications, application issues, incorrect specifications, and process irregularities.

#### Topics

- Identify troubleshooting theory
- Analyze process issues with the following measurements points:
  - o Pressure
  - o Temperature
  - o MultiVariable™ Flow
  - o Differential Pressure Level
  - o Guided Wave Radar
  - o Radar Level

#### Audience

Instrument technicians, I&E's

#### Prerequisites

Students should have at least two years of working experience and knowledge of: installation, configuration, commissioning, calibration, maintenance, and some basic troubleshooting experience.

### Rosemount OCX8800 Oxygen & Combustibles Transmitter – 2154

CEUs – 0.7

#### Overview

This 1-day course covers combustion measurement principles and the theory of operation for oxygen analyzers in general and the installation, operation, calibration and maintenance of the Rosemount OCX8800 Analyzers.

#### Topics

- Combustion Requirements
- Methods of Oxygen Analysis
- Typical Uses of Oxygen Analysis
- Combustion Efficiency
- Zirconia (ZrO<sub>2</sub>) Oxygen Analysis
- Theory of Operation
- Oxygen Analyzer
- COe Analyzer
  - Installation
  - Hardware
  - Maintenance
  - Troubleshooting
- Hart Communicatons



### Rosemount 3095MV & 305SMV MultiVariable Flow Transmitters – 2393 CEUs - 0.7

#### Overview

This 1-day course uses lecture and labs to teach the student how to install and maintain the Rosemount 3095MV & 3051SMV Smart Transmitters. The student will also learn the operation and interface capabilities of the Field Communicator. Students who complete this course will:

- identify transmitter parts and explain their functionality
- explain the principles of operation of the transmitter
- configure and test using the Field Communicator
- configure the compensated flow parameters using Engineering Assistant software with the 3095MV & 3051SMV
- properly install/troubleshoot transmitters

#### Topics

- DP Flow Fundamentals
- Overview and Principles of Operation
- Test Equipment Selection
- Bench Testing the Smart Transmitters
- Operation of the Field Communicator and AMS Device Manager
- Digital Trims/Calibration
- Installation and Start-Up
- Troubleshooting and Maintenance
- Configure/Wire/Setup the HART® Tri-Loop
- Operation of Engineering Assistant software

#### Audience

This course is designed for those individuals responsible for the installation and maintenance of the Rosemount 3095MV or 3051SMV Transmitter.

#### Prerequisites

Knowledge of basic pressure, temperature, and DP Flow fundamentals /instrumentation.

### Rosemount 3300 & 5300 Guided Wave Radar Level Transmitters – 2395 CEUs - 0.7

#### Overview

This 1-day course uses lecture and labs to maximize the hands-on experience and teach the student how to install, configure, troubleshoot and maintain the Rosemount 3300 & 5300 Series HART® Radar Level Transmitters.

#### Topics

Students who complete this course will be able to:

- explain the principles of operation of the 3300/5300 GWR
- identify 3300/5300 GWR parts and explain their functionality
- understand available probe options and when each should be used
- properly install and wire the 3300/5300 GWR
- configure and test the 3300/5300 GWR
- understand how to setup the 3300/5300 GWR to work in different applications
- properly troubleshoot the 3300 & 5300 GWR and the Installation using Radar Master software

#### Prerequisites

Knowledge of basic level fundamentals and instrumentation

### Rosemount Guided Wave & Non- Contacting Radar Level Transmitters – 2396 CEUs - 0.7

#### Overview

This 1-day course uses lecture and labs to maximize the hands-on experience and teach the student how to install, configure, troubleshoot and maintain the Rosemount 5400 & 5300 Series HART® Radar Level Transmitters. Students who complete this course will be able to:

- explain the principles of operation of the 5300/5400 radar
- identify 5300/5400 parts and explain their functionality
- properly install and wire the 5300/5400 Radar
- configure and test the 5300/5400 Radar
- properly troubleshoot the 5300/5400 Radar transmitter and installation using Radar Master software

#### Topics

- 5300/5400 Overview and Principles of Operation
- Installation of the 5300/5400 Radar
- Configuration of the 5300/5400 Radar
- Bench Testing the 5300/5400 Radar
- Field Communicator Operation
- AMS Device Manager Operation
- Radar Master Software Operation
- Calibration, Verification and Adjustments

- Troubleshooting and Maintenance
- Tank & Application/Probe Troubleshooting and Echo Handling Using Radar Master Software

#### Audience

This course is designed for those individuals responsible for the installation, configuration, calibration and maintenance of the Rosemount 5400 & 5300 Series HART® Radar Level Transmitters.

#### Prerequisites

Knowledge of basic level and interface fundamentals and instrumentation.

### Rosemount 3051 Pressure & 3144P Temperature Transmitter – 2398 CEUs - 0.7

#### Overview

This 1-day course uses lectures and labs to teach the student how to install and maintain the Rosemount 3051C Pressure and 3144P Smart Temperature Transmitter. The student will also learn the operation and inter-face capabilities of the Field Communicator. Students will:

- explain the differences between Smart & Analog transmitters
- identify 3051C and 3144P parts and functionality
- explain the principles of operation of the 3051C and 3144P Transmitters
- configure and test the 3051C Pressure and 3144P Temperature Transmitters using the Field Communicator
- properly install/ troubleshoot the 3051 Pressure and 3144P Temperature transmitters

#### Topics

- Smart and Analog Transmitters
- 3051C & 3144P Overview and Principles of Operation
- Test Equipment Selection
- Sensor Selection and Wiring
- Bench Testing the 3051C & 3144P Smart Transmitter
- Field Communicator Operation
- Digital Trims/Calibration
- Installation and Start-up
- Troubleshooting and Maintenance

#### Audience

This course is designed for those individuals responsible for the installation and maintenance of the Rosemount 3051 Pressure, and 3144P Temperature Transmitters.

#### Prerequisites

Knowledge of basic pressure and temperature fundamentals and instrumentation.

### Rosemount 8700 Series Smart Magnetic Flowmeter – Intermediate - 2340 CEUs - 0.7

#### Overview

This 1-day course consists of a blend of lectures and hands-on exercises that cover how to install, configure, and maintain the Rosemount 8700 Series Magnetic Flowmeter Systems composed of the Model 8712 and 8732 transmitters and the 8705 Flanged and 8711 Wafer Sensors. The students will learn the operation and capabilities of Local Operator Interface (LOI), 475 Field Communicator, and/or AMS Device Manager and how to use these tools to perform configuration. Common issues encountered and troubleshooting techniques will also be covered.

#### Topics

- Explain the Difference and Capabilities of the Rosemount 8700 Series Magnetic Flowmeters
- Identify Transmitter and Sensor Parts and Explain Functionality
- Explain Faraday's Law and the Principles of Operation of Magnetic Flowmeter System
- Configure and Test Transmitters Using the LOI, Field Communicator, or AMS Device Manager
- Properly Install/Troubleshoot the Rosemount Magnetic Flowmeter System

#### Audience

This course is intended for anyone that is involved with properly installing, wiring, configuring and troubleshooting a Rosemount 8700 Series Magnetic flowmeter. Typical job functions include: maintenance technicians, instrument technicians and instrumentation engineers.

#### Prerequisites

Knowledge of basic flow fundamentals and instrumentation.

### Rosemount – Spectrex Safeye Quasar 900 Open Path Gas Detector – 2349 CEUs – 0.7

#### Overview

This one-day course is designed to help students increase their skills and knowledge through hands-on learning covering topics such as: how it works, specification, proper configure, maintenance, and how to troubleshoot the Spectrex SafEye Quasar 900 Open Path Gas Detector Technical Training.

#### Objectives

At the end of this course, you should be able to:

- Explain how the Spectrex SafEye Open Path Gas Detector Works.
- How to put together a model number or decipher an existing model number
- Discuss the best installation practices

### 2349 – Continued...

- Configure the for given applications
- Perform routine maintenance on the gas detector system
- Troubleshoot the gas detector system

### Rosemount Plantweb Insight Configuration & Troubleshooting - Advanced – 2378 CEUs-0.1

#### Overview

This 2-hour course provides an overview of the Plantweb™ Insight applications and explains how to do advanced configuration and troubleshooting for the applications.

#### Topics

- Application Overview
- Global Settings
- Adding Assets
- Main Views - Dashboard, Asset Summary, Asset Details
- Analytics
- Modbus TCP Capabilities
- Troubleshooting

#### Objectives

- Describe the features and benefits of the Plantweb Insight Steam Trap application
- Identify the global application settings for Steam Trap in Plantweb Insight
- Add an asset to the Steam Trap application
- Explain the details of the Dashboard, Asset Summary and Asset Details views in Plantweb Insight
- Discuss how pre-built analytics work in Plantweb Insight
- Recognize the different Plantweb Insight statuses
- Explain the Modbus TCP Capabilities
- Troubleshoot issues with the Steam Trap application

### Rosemount - 8800 Series Smart Vortex Flowmeter - Intermediate - 2341 CEUs - 0.7

#### Overview

This 1-day course consists of a blend of lectures and hands-on exercises that cover how to install, configure, and maintain the Rosemount 8800 Series Smart Vortex flowmeter systems. The students will learn the operation and capabilities of the Local Operator Interface and HC475 Field Communicator and how to use these tools to perform configuration. Common issues encountered and troubleshooting techniques will also be covered.

#### Topics

- Explain the Differences and Capabilities of the Rosemount 8800 Series Vortex Flowmeters

- Explain the von Karman Effect and the Principles of Operation of Vortex Flowmeters.
- Identify Vortex Parts and Explain Functionality
- Configure and Test Transmitters using Field Communicator or AMS Device Manager
- Properly Install and Troubleshoot the Rosemount 8800 Series Vortex Flowmeter System

#### Audience

This course is intended for anyone that is involved with properly installing, wiring, configuring and troubleshooting a Rosemount 8800 Series Vortex Flowmeter. Typical job functions include; maintenance technicians, instrument technicians, and instrument engineers.

#### Prerequisites

None required. However, basic understanding of the fundamentals of flow measurement, electricity, analog & frequency signal processing are assumed.

### Rosemount Vortex Flowmeters with AMS Device Manager - Intermediate - 2341A CEUs - 0.7

#### Overview

This 1-day course consists of a blend of lectures and hands-on exercises that cover how to install, configure, and maintain the Rosemount 8800 Series Vortex flowmeter systems. The students will learn how to use AMS Device Manager to perform configuration. Common issues encountered and troubleshooting techniques will also be covered.

#### Topics

- Explain the Differences and Capabilities of the Rosemount 8800 Series Vortex Flowmeters
- Explain the von Karman Effect and Principles of Operation of Vortex Flowmeters
- Identify Vortex Parts and Explain Functionality
- Configure and Test Transmitters using the AMS Device Manager
- Properly Install and Troubleshoot the Rosemount 8800 Series Vortex Flowmeter System

#### Audience

This course is intended for anyone that is involved with properly installing, wiring, configuring and troubleshooting a Rosemount 8800 Series Vortex Flowmeter. Typical job functions include; maintenance technicians, instrument technicians, and instrument engineers.

#### Prerequisites

None required. However, basic understanding of the fundamentals of flow measurement, electricity, analog & frequency signal processing are assumed.

### Rosemount Vortex Theory and Specification - Introduction - e1020 CEUs – 0.2



#### Overview

Vortex Flow Meter Theory of Operation. You will learn about: The von Karman Effect; How vortex flow meters work, Vortex Flow Meter Product Overview. You will learn about: The Rosemount 8800 vortex vs traditional vortex flow meters; The vortex K-factor and how it is determined; The Rosemount vortex flow meter offering; Safety Instrumented Systems SIS. Vortex Flow Meter Sizing . You will learn: Why sizing a vortex meter is critical; Size and select a vortex meter using the Sizing and Selection tool; The considerations when determining vortex meter body style and size.

Vortex Flow Meter Model Numbers. You will learn about the Rosemount vortex model string and identify available options.

#### Topics

- This online training consists of 4 sections:
- Vortex Flow Meter Theory of Operation
- Vortex Flow Meter Product Overview
- Vortex Flow Meter Sizing
- Vortex Flow Meter Model Numbers

#### Objectives

- Explain how vortex flow meters work.
- Define the von Karman Effect
- List advantages and limitations of vortex technology.
- Explain the vortex K-factor and how it is determined.
- Compare the Rosemount 8800 Vortex vs Traditional Vortex Meters.
- Identify the Rosemount Vortex Flow Meter Offering.
- Explain Safety Instrumented Systems (SIS).
- Explain why sizing a vortex meter is critical.
- Describe how to size and select a vortex meter using the sizing and selection tool.
- Describe the considerations when determining vortex meter body style and size.
- Recognize the vortex flow meter model string and identify available options.

### Rosemount Vortex Installation Best Practices - Intermediate - e1021 CEUs – 0.2



#### Overview

This online training includes: Vortex Flow Meter Mounting, Vortex Flow Meter Piping Requirements, Vortex Flow Meter Installation Wiring, Vortex Flow Meter Installation Remote Electronics.

#### Topics

- Vortex Flow Meter Mounting
- Vortex Flow Meter Piping Requirements
- Vortex Flow Meter Installation Wiring
- Vortex Flow Meter Installation Remote Electronics

#### Objectives

- Describe the different process connections available with the vortex flow meter.
- Describe meter orientation in specific applications.
- Explain temperature sensor installation on a multivariable flow meter.
- Describe the ideal and acceptable piping requirements for the vortex flow meter.
- Explain the necessary requirements when using a temperature or pressure sensor in conjunction with the vortex flow meter.
- Describe location considerations when using the meter near pumps and valves. Identify the need for piping supports.
- Explain proper conduit installation
- Explain how to wire the vortex flow meter
- Describe the installation procedures for remote mount electronics.
- Describe the installation procedures for the temperature sensor on a remote MTA vortex meter.

#### Audience

This course is designed for personnel responsible for the installation, configuration, verification and maintenance of Rosemount Vortex flow meters.

### Rosemount Vortex Basic Configuration - Intermediate - e1022 CEUs – 0.2



#### Overview

This online training includes: Vortex Flow Meter Basic Configuration, Vortex Flow Meter Basic Configuration AMS Demonstration, Vortex Flow Meter Basic Configuration 475 Demonstration, Vortex Flow Meter Basic Configuration ProLink Demonstration.

#### Topics

- Vortex Flow Meter Basic Configuration
- Vortex Flow Meter Basic Configuration AMS Demonstration
- Vortex Flow Meter Basic Configuration 475 Demonstration
- Vortex Flow Meter Basic Configuration ProLink Demonstration

#### Objectives

- Describe the key configuration parameters for a vortex flow meter.
- Explain how to configure a vortex meter using AMS, ProLink and the Field Communicator.
- Explain how to configure a vortex meter using AMS device Manager.
- Explain how to perform a basic configuration of a vortex transmitter using the 475 HART Hand Held Field Communicator.
- Identify the following 8 steps in the basic configuration setup of a vortex flow meter using ProLink III: Process Configuration, K-factor, Flange Type, Mating Pipe ID, Variable Mapping, Primary Variable Units, Variable Range Values (Upper Range Value (URV), Lower Range Value (LRV)), Optimize the Flow Range

#### Audience

This course is designed for personnel responsible for the installation, configuration, verification and maintenance of Rosemount Vortex flow meters.  
Prerequisites  
None

### Rosemount Vortex Configuration - Advanced - e1023

CEUs – 0.3

#### Overview



This online training

includes: Vortex Flow Meter Advanced Configuration, Vortex Flow Meter Advanced Configuration AMS Demonstration, Vortex Flow Meter Advanced Configuration 475 Demonstration, Vortex Flow Meter Advanced Configuration ProLink.

#### Objectives

- Describe advanced configuration for: Special units of measure, Base volume units - density ratio, Pulse output, Totalizer, Display variables, Saturated steam using the MTA option.
- Explain how to use AMS to perform six advanced configurations on a vortex meter.
- Describe how to perform six advanced configurations on a vortex meter using the HART Field Communicator. Explain how to use ProLink III to perform six advanced configuration setups on a vortex flow meter.

#### Topics

- Vortex Flow Meter Advanced Configuration
- Vortex Flow Meter Advanced Configuration AMS Demonstration
- Vortex Flow Meter Advanced Configuration 475 Demonstration
- Vortex Flow Meter Advanced Configuration ProLink

#### Audience

This course is designed for personnel responsible for the installation, configuration, verification and maintenance of Rosemount Vortex flow meters.

### Rosemount Vortex Troubleshooting - Advanced - e1024

CEU's – 0.3

#### Overview



This online training :

Vortex Flow Meter Vibration Mass Balancing and Filter Adjustment, Vortex Flow Meter Vibration Mass Balancing and Filter Adjustment AMS Demonstration, Vortex Flow Meter Vibration Mass Balancing and Filter Adjustment 475 Demonstration, Vortex Flow Meter Electronics Sensor Process Troubleshooting, Vortex Flow Meter Electronics Sensor Process Troubleshooting AMS Demonstration, Vortex Flow Meter Electronics Sensor Process Troubleshooting 475 Demonstration, Vortex Flow Meter Electronics Sensor Process Troubleshooting ProLink Demonstration, Vortex Flow Meter Troubleshooting Scenarios.

#### Topics

- Vortex Flow Meter Vibration Mass Balancing and Filter Adjustment
- Vortex Flow Meter Vibration Mass Balancing and Filter Adjustment AMS Demonstration
- Vortex Flow Meter Vibration Mass Balancing and Filter Adjustment 475 Demonstration
- Vortex Flow Meter Electronics Sensor Process Troubleshooting
- Vortex Flow Meter Electronics Sensor Process Troubleshooting AMS Demonstration
- Vortex Flow Meter Electronics Sensor Process Troubleshooting 475 Demonstration
- Vortex Flow Meter Electronics Sensor Process Troubleshooting ProLink Demonstration
- Vortex Flow Meter Troubleshooting Scenarios

#### Objectives

- Describe how to use AMS to filter out pipe vibration.
- Explain how to use a 475 Field Communicator to filter out pipe vibration.
- Explain how to use meter verification to verify the functionality of the electronics.
- Recognize sensor health and measure the impedance of the vortex piezoelectric sensor.
- Explain process variations that may cause unexpected changes in vortex meter performance.
- Describe some of the tools in AMS that can be used to troubleshoot a transmitter.
- Describe how to use a 475 Field Communicator to follow the ESP troubleshooting method.
- 
- 

### e1024 – Continued...

- Describe some of the tools in ProLink that can be used to troubleshoot a faulty meter.
- Identify some of the common troubleshooting issues and describe some of the main causes of these issues.

#### Audience

This course is designed for personnel responsible for the installation, configuration, verification and maintenance of Rosemount Vortex flow meters.

#### Prerequisites

None



## Rosemount Tank Gauging Systems- RTG101

### CEUs - 3.5

This course is suitable for service engineers and can also be good for project and sales engineers. It is a good introduction for both employees and customers. The course includes both practical and theoretical training.

#### Overview

This 5-day Tank Gauging Technical Product Training focuses on the 5900 System, our Wireless Tank Gauging System, a little bit about Pro & Rex and other field equipment relevant to the Rosemount Tank Gauging System. The training covers installation, configuration and troubleshooting of our products, as well as general TankMaster functions.

Students who complete this course will be able to:

- Perform Installation and Setup Procedures
- Configure Tank Gauging System
- Plan a Wireless Installation
- Perform Basic Troubleshooting

#### Topics

- System Overview
- Rosemount 2460 System Hub
- Rosemount 2410 Tank Hub
- Rosemount 5900 Gauges
- Rosemount 2230 Graphical Field Display
- Rosemount 2240S Multi-Input Temperature Transmitter
- Rosemount 5408
- Field Communication and TCP/IP
- Electrical and Mechanical Installation
- System Configuration
- LPG/LNG
- Emerson Wireless
- AMS Wireless Snap-On
- Gateway
- Emulation
- Overfill Prevention
- SIL
- Troubleshooting

#### Audience

This course is for service engineers and can also be good for project and sales engineers. The course includes both practical and theoretical training and is open for employees, LBPs and customers.

#### Prerequisites

Technical Background

## Rosemount Tank Gauging REX & PRO Series - Introduction- RTG130

### Overview

This 1-day Tank Gauging Technical Product Training focuses on the REX and PRO series systems. The training covers installation, configuration and troubleshooting as well as general TankMaster functions. Students who complete this course will:

- Correctly perform installation and setup procedures
- Properly configure Tank Gauging System using TankMaster
- Perform basic troubleshooting

## RTG130 – Continued...

### Topics

- System Overview
- REX 3900 Series
- PRO 40 Series
- Field Communication
- Electrical and Mechanical Installation
- System Configuration
- LPG/LNG
- Emulation
- Troubleshooting

### Audience

This course is designed for personnel responsible for the installation, configuration, verification and maintenance of the Rosemount PRO/5600 and REX/3900 Tank Gauging Systems.

### Prerequisites

This course is suitable for service, project, and sales engineers, and is a good start for new employees and customers.

## Rosemount TankMaster Software – Introduction - RTG102

### CEUs – 2.5

This course is suitable for anyone who works with TankMaster, including customers who is using WinOpi as the operator interface. The course includes both practical and theoretical training.

#### Overview

This 4-day TankMaster Training covers more detailed information about TankMaster functions. Students who complete this course will be able to:

- Perform System Configuration
- Configure Host Communication
- Properly use Redundancy
- Use Batch Handling
- Program Basic Custom Views
- Perform Basic Troubleshooting

#### Topics

- System Overview
- Volume Calculations
- WinOpi Tools Menu
- Host Communication, TCP/IP and OPC
- TankMaster Batch
- Custom Views and Translation
- Network Basics
- TankMaster to Enraf
- Redundancy
- Floating Roof Monitoring
- Administrator Program, Backup & Restore
- TankMaster Hybrid & HTG
- Troubleshooting

#### Audience

This course is for anyone who works with TankMaster, including customers who is using WinOpi as the operator interface. The course is open for Emerson employees, LBPs and customers.

#### Prerequisites

It is required that you previously attended the RTG101 Technical Product Training course or have very good knowledge of the Rosemount Tank Gauging System.

## Rosemount Tank Gauging System – RTG 110

### CEUs – 2.1

This course is designed for personnel responsible for the installation, configuration, verification and maintenance of the Rosemount PRO/5600, REX/3900 and Raptor/5900 Tank Gauging Systems including Smart Wireless solutions.

#### Overview

This 3-day Tank Gauging Technical Product Training focuses on the complete 5900, REX and PRO series tank gauging systems plus wireless application. Configuration via TankMaster(TM) WinSetup software. The training covers installation, configuration and troubleshooting of our products, as well as general TankMasterTM functions.

Students who complete this course will:

- Correctly perform installation and setup procedures
- Properly configure Tank Gauging System using TankMaster
- Perform basic troubleshooting

#### Topics

- Rosemount TankMaster
- Rosemount 2460 System Hub
- Rosemount 2160 Field Communication Unit
- Rosemount 2410 Tank Hub
- Rosemount 5900 Radar Level Gauge
- Rosemount 2240 Multi-Temp Transmitter
- Rosemount 644 Single Temp Transmitter
- Rosemount 2230 Graphical Field Display
- Rosemount 1420/1410 Wireless Gateways
- Rosemount 775 THUM Adapter
- Rosemount REX 3900 Series
- Rosemount PRO 5600 Series
- Electrical and mechanical installation
- Field communication including Modbus and FF
- Commissioning, verification and troubleshooting

#### Audience

This is a general, all-inclusive, start-from-scratch course that is suitable for both commissioning and maintenance personnel as well as project and engineering personnel involved in tank gauging

#### Prerequisites

No previous knowledge about the Rosemount tank gauging system is required to participate in this course. It is recommended that participants have some general knowledge about instrumentation and computers.



### Rosemount Tank Gauging 5900 Series - Introduction – RTG111

#### CEUs – 0.7

#### Overview

This 1-day course is designed for personnel responsible for the installation, configuration, verification and maintenance of the Rosemount Tank Gauging System. This Level 1 training covers main tank side product installations and basic configuration via TankMaster™ WinSetup software application.

#### Topics

- Rosemount TankMaster™
- Rosemount 5900 Radar Level Gauge
- Rosemount 2410 Tank Hub
- Rosemount 2230 Graphical Field Display
- Rosemount 2240 Multi-Temperature Transmitter
- Electrical and Mechanical Installation
- Field Communications – Tankbus (FF)
- Commissioning
- Verification and Calibration

#### Audience

This course is designed for personnel responsible for the installation, configuration, verification and maintenance of the Rosemount Raptor/5900 Tank Gauging Systems.

#### Prerequisites

This is start-from-scratch course that is suitable for both commissioning and maintenance personnel as well as project and engineering personnel involved with tank gauging systems. No previous knowledge about the Rosemount Tank Gauging Systems is required, but it is recommended to have some general knowledge about instrumentation and computers. This course also serves as a great refresher for personnel that have previously attended the RTG110 or RTG101 courses.

### Rosemount TankMaster Software - Introduction – RTG 120

#### CEUs – 0.7

#### Overview

This 1-day TankMaster Training covers the Inventory Management application (WinOpi). The course is suitable for anyone who works with TankMaster using WinOpi as the operator's interface. The training covers inventory configuration and management, reports, user accounts and program access control, operator handling of inventory, as well as alarm system and batch system.

### RTG 120 – Continued...

#### Topics

- Correctly perform installation of TankMaster
- Properly configure TankMaster Inventory Management System
- Operational use of TankMaster WinOpi application
- System Overview

#### Audience

This course is designed for personnel responsible for installation, configuration, verification and maintenance of the Rosemount Raptor/5900 Tank Gauging Systems.

#### Prerequisites

No previous knowledge about Rosemount Tank Gauging system is required to participate in this course. It is recommended that participants have some general knowledge about instrumentation and computers.

### Rosemount 5900 Series Tank Gauging - Introduction, Intermediate, Advanced - RTG210

#### CEU – 2.1

#### Overview

This 3-day combination course is designed for personnel responsible for the installation, configuration, verification and maintenance of the Rosemount Tank Gauging System. The training covers all aspects of the 5900 series gauging system with installation, configuration, and troubleshooting of our products via TankMaster™ WinSetup software application.

#### Topics

- Rosemount TankMaster™
- Rosemount 2460 System Hub
- Rosemount 5900 Radar Level Gauge
- Rosemount 2410 Tank Hub
- Rosemount 2230 Graphical Field Display
- Rosemount 2240 Multi-Temperature Transmitter
- Rosemount 644 Temperature Transmitter
- Rosemount 1410/1420 Wireless Gateways
- Rosemount THUM 775 Wireless Adapter
- Electrical and Mechanical Installation
- Device Management
- LPG/LNG Installations
- 2410 Multi-Tank Installations
- Field Communications – Tankbus (FF)
- Field Communications – Modbus
- Field Communications – Wireless Hart
- Commissioning
- Level Verification and Hand Gauging
- Troubleshooting

#### Audience

This course is designed for personnel responsible for the installation, configuration, verification and maintenance of the Rosemount Raptor/5900 Tank Gauging Systems.

### RTG210 – Continued...

#### Prerequisites

This is start-from-scratch course that is suitable for both commissioning and maintenance personnel as well as project and engineering personnel involved with tank gauging systems. No previous knowledge about the Rosemount Tank Gauging Systems is required, but it is recommended to have some general knowledge about instrumentation and computers.

### Rosemount 5900 Series Tank Gauging - Intermediate - RTG211

#### CEU – 0.8

#### Overview

This 1-day course is designed for personnel responsible for the installation, configuration, verification and maintenance of the Rosemount Tank Gauging System. This Level 2 training covers advanced installation and configuration as well as troubleshooting of our products via TankMaster™ WinSetup software application.

#### Topics

- Rosemount TankMaster™
- Rosemount 5900 Radar Level Gauge
- 2-in-1 Dual Radar Head
- Advanced Tankscan/Echo Curve
- Advanced Diagnostics
- Rosemount 2410 Tank Hub
- Density Calculations
- Analog Output
- Relay Output
- Advanced Diagnostics
- Rosemount 644 Temperature Transmitter
- Device Management
- Backups
- Replacements
- LPG/LNG Installations
- 2410 Multi-Tank Installations
- Overfill systems
- Troubleshooting

#### Audience

This course is designed for personnel responsible for the installation, configuration, verification and maintenance of the Rosemount 5900 Tank Gauging Systems.

#### Prerequisites

This course requires students to have completed the RTG111 5900 Series Level 1 course. RTG111 and RTG211 courses can be completed in same week as a combination course. Separate signup will be required for each of the two courses. Students that have previously attended the RTG110 or RTG101 courses also eligible to sign up for this course.

### Rosemount TankMaster Software – Intermediate - RTG220

CEUs – 0.7

#### Overview

This 1-day TankMaster training covers more detailed information about TankMaster advanced functions. This course is suitable for anyone who works with TankMaster from an IT and networking aspect with management of clients, redundancy, Tankmaster.Net web server, host interfacing to 3rd party applications and program access control.

#### Topics

- Correctly perform installation of TankMaster systems
- Properly configure TankMaster networking applications
- Perform basic troubleshooting of TankMaster applications
- System Overview

#### Audience

This course is designed for personnel responsible for the installation, configuration, operation and maintenance of the Rosemount TankMaster Systems focusing on server/client/web and networking functions.

#### Prerequisites

It is necessary that participants have attended the RTG120 course prior to taking this course.

### Rosemount 5900 Series Tank Gauging Training - Advanced - RTG311

CEU – 0.8

#### Overview

This 1-day course is designed for personnel responsible for the installation, configuration, verification and maintenance of the Rosemount Tank Gauging System. This Level 3 training covers installation, configuration, and troubleshooting of our products via TankMaster™ WinSetup software application.

#### Topics

- Rosemount TankMaster™
- Rosemount 2460 System Hub
- Rosemount 1410/1420 Wireless Gateways
- Rosemount THUM 775 Wireless Adapter
- Electrical and Mechanical Installation
- Field Communications – Modbus
- Field Communications – Wireless Hart
- 2460 Inventory Systems
- Commissioning
- Troubleshooting

#### Audience

This course is designed for personnel responsible for the installation, configuration, verification and maintenance of the Rosemount 5900 Tank Gauging Systems.

#### Prerequisites

This course requires students to have completed the RTG111 and RTG211 5900 Series Level 1 and 2 courses.

### Rosemount Oxygen Flue Gas & 6888A Analyzers – 2153

CEUs – 0.7

#### Overview

This 1-day course covers combustion measurement principles and the theory of operation of oxygen analyzers. The class will discuss the installation, operation, calibration and maintenance of the Rosemount 6888A Oxygen Analyzer.

#### Topics

- Combustion Requirements
- Methods of Oxygen Analysis
- Typical Uses of Oxygen Analysis
- Combustion Efficiency
- Zirconia (ZrO2) Oxygen Analysis
- Theory of Operation
- Oxygen Analyzer
  - Installation
  - Hardware
  - Maintenance
  - Troubleshooting
- Hart Communicatons

### Rosemount Plantweb Insight Installation & Setup – 2377

CEUs – 0.1

#### Overview

This 1/2 day course introduces Plantweb™ Insight and how to do the initial installation and setup of the software platform.

#### Topics

- Plantweb Insight Introduction
- Plantweb Insight Initial Installation
- Virtualization Overview
- Hypervisor Examples (VMware or Microsoft Hyper-V)
- Technical Requirements
- Reference Architectures
- Plantweb Insight Setup and System Settings
- Basic Navigation

#### Objectives

- Provide an overview of the Plantweb Insight platform
- Explain the benefits of Plantweb Insight and how it helps customers identify abnormal situations faster
- Identify the three main views of the Plantweb Insight web-based interface
- Demonstrate the initial installation and setup process for Plantweb Insight

### Rosemount - MLT Process Gas Analyzers – 2110

CEUs – 2.1

#### Overview

This 3-day course is a classroom training where students learn principles and practical operation of MLT analyzers. Through hands-on training, the student will learn on how to install, maintain, and troubleshoot the MLT analyzer. Using MLT Analyzer demo units, students will:

- Understand the Photometric measurement principles such as the

theory of Infrared and Ultraviolet Spectrometry, Paramagnetic and Thermal Conductivity

- Learn the signal processing of the electronic boards.
- Learn the test procedure for troubleshooting and diagnostics

#### Topics

- Introduction to the function of Physical parts
- Function of Electronic boards
- Test points and procedure
- Mechanical Assembly / Disassembly
- Programming of software parameters
- Calibration setup manual (Auto calibration when available)
- Analog outputs, and Digital Inputs / Outputs
- Save / Load configuration functionality
- Spare parts

#### Prerequisites

Basic Knowledge of PGA Analysers would be helpful

### Rosemount MLT Continuous Gas Analyzer for Continuous Emissions Monitoring Systems– 2156

CEUs – 2.1

#### Overview

This 3-day Course combines lectures hands-on labs to maximize the students understanding of the MLT Continuous Gas Analyzer.

- Environmental Requirements
- Process Applications
- Theory Operations
- Sample System Instrument
  - Installation and Troubleshooting
  - Hardware and Maintenance

#### Audience

Target Audience is intended, but not limited to, instrument technicians and engineers responsible for the maintenance of the MLT.

### Rosemount X-Stream Gas Analyzer for Continuous Emissions Monitoring Systems– 2157

#### Overview

This 3-day course covers basic fundamentals and the theory of operation, installation, calibration and maintenance of Continuous Emissions Monitoring Systems (CEMS).

- Environmental Requirement
- Process Applications
- Theory of Operation
- Sample System Instrument
  - Installation and Troubleshooting
  - Hardware and Maintenance

#### Audience

This course is for instrument technicians responsible for the maintenance of continuous emissions monitoring systems.

### Rosemount Liquid Analysis General pH, Conductivity, and ORP Theory - 2800 CEUs – 1.4

#### Overview

This 2-day course combines lectures with bench-top labs and uses the interactive plant for scenario-based training. Target students are individuals responsible for the installation, configuration, calibration and maintenance of Rosemount Analytical pH, Conductivity, and ORP sensors and analyzers. Students shall apply classroom knowledge directly to the interactive plant scenario labs. Be ready to learn in a "real world" plant environment.

#### Topics

- Identify Sensor Parts and Functionality
- Explain the Principles of Operation of pH, Conductivity, and ORP sensors
- Configure, Calibrate and Test Analyzers
- Properly Install and Troubleshoot pH, Conductivity, and ORP Sensors Along with Analyzers
- Students shall ensure proper PPE and safety measures while working on the plant.

### Rosemount X-Stream Process Gas Analyzers – 2170 CEUs – 2.1

#### Overview

This 3-day course is a classroom training where students learn principles and practical operation of XE analyzers. Through hands-on training, the student will learn on how to install, maintain, and troubleshoot the XE analyzer.

Using XE Analyzer demo units students will:

- Understand the Photometric measurement principles such as the theory of Infrared and Ultraviolet Spectrometry, Paramagnetic and Thermal Conductivity
- Learn the signal processing of the electronic boards.
- Learn the test procedure for troubleshooting and diagnostics

#### Topics

- Introduction to the function of Physical parts
- Function of Electronic boards
- Test points and procedure
- Mechanical Assembly / Disassembly
- Programming of software parameters
- Calibration setup manual (Auto calibration when available)
- Analog outputs, and Digital Inputs / Outputs and Modbus setup
- Save / Load configuration functionality
- Spare parts
- Troubleshooting Procedure

#### Prerequisites

Basic Knowledge of PGA Analysers would be helpful

### Rosemount - Gas Analysis: Safety Training for On-Line Process Gas Analyzers – 2171

#### Overview

This fully customized 5-day course provides students with a strong understanding of gas analyzer best practices as they relate to the safe operation and maintenance of the specific models of Rosemount Analytical Gas Analyzers found in their plants, including the NGA2000, MLT, Binos, CLD, X-STREAM, and X-STREAM XE. The instructor focuses on the specific analyzers that are applicable to the students' specific needs. This course emphasizes safe handling of Rosemount Analytical analyzers. All necessary equipment and important handouts will be provided.

#### Topics

- Analyzer Overview, Including Hardware and Construction
- Software Functionality
- Physical Principals of IR and UV Photometric Measurements and Oxygen Paramagnetic Measurements
- Overview of the Electronics
- Replacement of Physical Components
- Testing and Troubleshooting
- Spare Parts
- Mechanical Assembly/Disassembly
- Sample Handling System – Method, Theory, and Troubleshooting
- Site-specific Applications
- Theory of Operation
- Installation and Start Up
- Troubleshooting and Maintenance
- Audit and Reporting Requirements

### Rosemount 500 Gas Chromatographs - Introduction - R4100 CEUs - 2.1

#### Overview

This 3-day course gives students a basic understanding of how the Rosemount Analytical 500 and 700 gas chromatographs (formerly Danalyzer GCs) work, emphasizing chromatograph fundamentals and basic theory.

#### Topics

- Reviewing Basic Chromatography Principles
- Understanding Chemistry, Flow Configuration, and Gas Systems
- Understanding Basic Sample Systems
- Working with Chromatograph Hardware
- Setting Timed Events, Retention Times, and Response Factors
- Understanding Data Calculations
- Identifying Problems Using Chromatograms

### Rosemount 500 Process Gas Chromatograph – Intermediate - R4210 CEUs - 2.8

#### Overview

This 5-day course is appropriate for those who have either worked with a Gas Chromatograph for at least six months or completed the Introductory Gas Chromatograph course. It prepares participants to operate and repair a Model 500 Gas Chromatograph.

#### Topics

- Understanding Gas Chromatography and a Gas Chromatograph
- Using the Basic Chromatograph System in Process Gas Analysis
- Understanding Carrier and Calibration Gas Systems
- Installing and Operating MON Software
- Applying Chromatograph Integration Techniques and Post-Analysis Calculations
- Using the Chromatograph to Identify Problems
- Setting Timed Events, Retention Times, and Response Factors
- Starting Up a Gas Chromatograph
- Understanding Sample Handling Systems
- Verifying Proper Operation of a Gas Chromatograph
- Troubleshooting the 2350A Controller
- Configuring the 2350A Controller User Directory Outputs
- Conducting Preventative Maintenance
- Communicating to Other Devices
- Reviewing Spare Parts Recommendations

#### Prerequisites

Students that have at least 6 months experience with Emerson GC's, just purchased an Emerson GC or are seeking a refresher course after having worked on their Emerson GC benefit most from this course. Candidates from non-technical backgrounds should consider taking R4100 Introduction to GC's (for Model 500, 700 or 1000)

### Rosemount - Gas Chromatographs - Introduction, Model 700XA & 1500XA - R4105 CEUs - 2.1

#### Overview

This 3-day course gives students basic understanding of how Rosemount Analytical gas chromatographs 700XA & 1500XA (formerly Danalyzer GCs) work, emphasizing chromatograph fundamentals and basic theory.

#### Topics

- Reviewing Chromatography Principles
- Understanding Chemistry, Flow Configuration, and Gas Systems
- Reviewing Sample Systems
- Working with Chromatograph Hdwe
- Setting Timed Events, Retention Times, and Response Factors
- Understanding Data Calculations
- Reading Chromatograms
- Calibrating a Gas Chromatograph

Classes typically start at 8AM CST on Tuesday and end at 5PM CST on Thursday to accommodate travel.

### Rosemount 370XA Gas Chromatograph – Introduction – E4070



#### Overview

Online introduction to Rosemount's 370XA Gas Chromatograph.

#### Topics

- Reviewing 370XA features
- Installation
- Calibration
- Introducing the Maintainable Module™
- Reading Chromatograms

### Rosemount Tank Gauging System Overview - eRTG100 CEUs – 0.05



#### Overview

Learn the fundamentals of the Rosemount Tank Gauging System, including basic components and their features, different configurations and system integration. Point out the unique functionality, features and benefits of the Rosemount Tank Gauging System – Describe the different tank Gauging devices – Compose your own tank gauging.

### Rosemount 370XA Gas Chromatograph - Intermediate - R4170 CEUs – 2.1

#### Overview

This 3-day training is a level 1 course and includes theory, operations and maintenance practices for the Rosemount Analytical 370XA Gas Chromatograph (formerly Danalyzer GC). Module overview hardware and software overview as well as basic troubleshooting skills.

#### Topics

- Chromatographic Theory
- Detector Theory
- Understanding Chromatograms
- Startup Procedures
- Natural Gas Sample Handling
- Using 370XA Software Assistants
- Cal-Saver™
- Running Auto Valve Timing
- Module Initializations
- Calibrations, Validation & Routine Maintenance (Valve Rebuilding)
- Troubleshooting the module
- 370XA Hardware
- MON2020 Software

#### Prerequisite

E4070 Introduction to the Model 370XA.

### Rosemount - Operation & Maintenance - Model 700 - Gas Chromatograph - R4212 CEUs – 2.8

#### Overview

This 5-day course is appropriate for those who have either worked with a chromatograph for at least six months or completed the Introductory Gas Chromatograph course. It prepares participants to operate and repair a Rosemount Analytical 700 Gas Chromatograph. It prepares participants to operate and repair a Model 700 gas chromatograph.

#### Topics

- Understanding Gas Chromatography and Gas Chromatographs
- Using the Basic Chromatograph System in Process Gas Analysis
- Understanding Carrier and Calibration Gas Systems
- Installing and Operating MON Software
- Applying Chromatograph Integration Techniques and Post-Analysis Calculations
- Using the Chromatograph to Identify Problems
- Setting Timed Events, Retention Times, and Response Factors
- Starting Up a Gas Chromatograph
- Understanding Sample Handling Systems
- Verifying Proper Operation of the Gas Chromatograph
- Conducting Preventative Maintenance
- Communicating to Other Devices

#### Prerequisites

Students that have at least 6 months experience with Emerson GC's, just purchased an Emerson GC or are seeking a refresher course after having worked on their Emerson GC benefit most from this course. Candidates from non-technical backgrounds should consider taking R4100 Introduction to GC's (for Model 500, 700 or 1000)



### Rosemount 700XA & 1500XA Process Gas Chromatograph - Intermediate - R4213/R4214CEUs – 2.8

#### Overview

This 5-day course is appropriate for those who have either worked with a GC for at least six months or completed the introductory gas chromatograph course. It prepares participants to operate and repair a Rosemount Analytical 700XA & 1500XA Gas Chromatograph.

#### Topics

- Understanding Gas Chromatography and Gas Chromatographs
- Using the Basic Chromatograph System in Process Gas Analysis
- Understanding Carrier and Calibration Gas Systems
- Installing and Operating MON Software
- Applying Chromatograph Integration Techniques and Post-Analysis Calculations
- Using the Chromatograph to Identify Problems
- Setting Timed Events, Retention Times, and Response Factors
- Starting Up a Gas Chromatograph
- Understanding Sample Handling Systems
- Verifying Proper Operation of the Gas Chromatograph
- Conducting Preventative Maintenance
- Communicating to Other Devices
- Reviewing Spare Parts Recommendations

#### Audience

This course is best suited for students working in a technical environment.

#### Prerequisites

Students that have at least 6 months experience with Emerson GC's, just purchased an Emerson GC or are seeking a refresher course after having worked on their Emerson GC benefit most from this course. Candidates from non-technical backgrounds should consider taking R4105 Introduction to GC's (for 700XA/1500XA).

### Rosemount Gas Chromatograph Flame Photometric Detector Module - Operation & Maintenance - R4215 CEUs – 2.8

#### Overview

The 5-day course covers the theoretical and practical aspects of the flame Photometric Module [FPD] used with the model 500, 700 and 700XA. It does not cover any aspect of the theory of the model 500, 700 or 700XA neither does it cover the menus and use of MON2000/ MON2020. The course concentrates on practical work. The course is aimed at those who will be carrying out maintenance on the FPD module.

#### Topics

- Sulphur
- FPD Theory and Maintenance
- Applications
- Dismantling and Rebuilding a Flame Cell Replacing all the "O" Rings
- Removing/Installing the Flame Cell and Photomultiplier into the FPD Module
- Setting Up the Hydrogen/Air Ratio to Achieve Continuous Combustion
- Adjusting the Entry of the sample into the Flame Cell
- Setting Up the Flame Out Circuit
- Adjusting the Amplifier to Optimize Peak Amplitude
- FPD Chromatograms
- Routine Maintenance
- Fault Finding

#### Prerequisites

Students attending this course must have completed either of these Operations & Maintenance courses: R4210, R4212, or R4213/R4214.

### Rosemount 500 Process Gas Chromatographs - Advanced - R4311 CEUs – 2.8

#### Overview

This 5-day course is most valuable to those with three years of chromatography experience, or those who have completed the introductory 'Operation and Maintenance of Gas Chromatographs' course. Participants will develop an advanced understanding of gas chromatograph operation, troubleshooting, and maintenance. Training becomes customized when students present application information. Given that data, the experienced instructor will look closely at specific applications and offer participants insight.

#### Topics

- Understanding Chromatograph Flow Configurations
- Overhauling Valves
- Reviewing Thermal Conductivity, Flame Ionization, and Flame Photometric Detectors
- Understanding Sample/Carrier/Calibration Gas Systems
- Working with and troubleshooting the Rosemount Analytical 2350A Controller
- Installing and Using MON Software for Integration and Calibration
- Setting Timed Events, Retention Times, and Response Factor Calculations
- Understanding Startup Procedures
- Setting Valve Timing and Flows with Different Flow Configurations
- Checking for Proper Separation and Analyzing Gas Chromatographs
- Verifying Proper Operation of the Gas Chromatograph
- Troubleshooting the Chromatograph and 2350A Controller
- Configuring Reporting Details and Control Outputs
- Conducting Preventative Maintenance
- Communicating to Other Devices
- Reviewing Spare Parts Recommendations

#### Prerequisites

Students attending this course must have completed either of these Operations & Maintenance courses: R4210, R4212, or have 3 years of advanced chromatography experience



### Rosemount 700XA Process Gas Chromatographs - Advanced - R4315/R4316 CEUs – 2.8

#### Overview

This 5-day course equips students with a full understanding of many advanced techniques used in process gas chromatography. An experienced instructor and focused material enable students to troubleshoot a variety of field issues for the Rosemount Analytical 700XA & 1500XAGC.

#### Topics

- Setting Valve Timing
- Hardware Troubleshooting
- Mixture Adjustments for FID
- Mixture Adjustment for FPD
- Verifying proper operation of the Gas Chromatograph
- Overview of Model 1500XA
- Liquid Sample Injection
- Review of Sample System Techniques
- Calibration and Accuracy Checks
- Recovery of GC After Analysis Interruption
- GC Start-up After Overhaul
- Communicating to Other Devices
- Understanding flow settings for various flow configurations
- Understanding when to overhaul valves

#### Prerequisite

Students attending this course must have completed either of Operations & Maintenance course R4213/R4214 or have 3 years of advanced chromatography experience.

### Rosemount - Four-Wire Liquid Analyzers - 56, 1056, & 1057 – 2204 CEUs - 0.2

#### Overview

This 2-hour class covers features, benefits and operation of Rosemount Analytical Models 56, 1056 or 1057. Each analyzer family can measure pH, ORP, contacting conductivity, toroidal conductivity, chlorine, oxygen, and ozone. The Model 1056 can also measure Turbidity in drinking water, flow from a pulse sensor and display any 4 to 20mA signal input. Each instrument has its own available features, and menu tree which will be covered in detail.

#### Topics

- Installation and Application Problems
- Configuration of Outputs / Alarms (If Applicable)
- Programming of Automated Cleaning Systems (DO, pH)
- Use Diagnostic Features (If Applicable)
- Sensor Calibration
- Troubleshooting

### Rosemount Liquid Analysis pH, Conductivity & ORP Theory– 2200 CEUs - 0.7

#### Overview

This 1-day course provides a solid theoretical background in pH, Conductivity, and ORP measurements. Students who complete this course will be able to:

- Understand how each measurement is made
- Recognize installation/application problems
- Configure and calibrate instruments
- Implement a maintenance program
- Troubleshoot problems using diagnostics

#### Topics

- What is pH/Conductivity/ORP
- How pH/Conductivity/ORP Measurements are Made
- Physical Process Properties and How They Effect On-Line Measurements
- Proper Calibration Techniques
- Cleaning and Maintenance of a Sensor
- Choosing Correct Sensor for Any Process
- How to Decipher Diagnostics Readouts
- pH/Conductivity Sensor Overview
- pH/Conductivity/ORP Analyzer Overview

### Rosemount 1056 Dual Input Analyzer - e2601 CEUs - 0.10



#### Overview

Introduction to the 1056 Dual Input Analyzer, including overview of functions, mechanical and electronic installation, adding sensor boards and wiring sensors, and using the interface.

Basic installation, configuration and calibration training in the 1056 Analyzer.

### Rosemount - pH Theory - Level 1 - e2602 CEUs - 0.1



#### Overview

Entry level training in pH Theory, including explanation of pH measurement, industries utilizing measurement, types of pH measurement, science of determining pH, and examination of a pH detector and sensor.

Explain pH to learner to impart a solid, working knowledge of pH and how it is measured and why, in industry, and understanding of pH scale, and pH sensors.

### Rosemount Liquid Analysis Chlorine, Dissolved Oxygen & Ozone Amperometric Measurement Theory– 2201 CEUs - 0.7

#### Overview

This 1-day course provides insight into the complicated amperometric measurements of chlorine, dissolved oxygen and ozone. Students will learn the concepts of how amperometric sensors work and how to calibrate each type of measurement. Students who complete this course will be able to:

- Understand the theory behind how amperometric sensors work and how to calibrate each type of measurement
- Differentiate the various species of chlorine
- Implement a proper maintenance program
- Use diagnostics to troubleshoot problems

#### Topics

- Amperometric Measurement Theory:
- Chlorine/Dissolved Oxygen/Ozone
- Calibration Procedures for Each Measurement
- Maintenance & Troubleshooting Tips

### Rosemount Liquid Analysis Measurement Theory– 2205 CEUs - 0.7

#### Overview

This 7-hour class is fully customized to cover the specific measurements that the customer requests. A certified trainer will cover up to 4 subjects in one day. The 4 subjects may be measurement or product related. The list of measurements that can be bundled into a tailored made training course are pH, ORP, contacting conductivity, toroidal conductivity, turbidity, chlorine, dissolved oxygen, and ozone. Each measurement theory has its own duration which can be modified to fit the customers' time frame needs. Select an analyzer (course 2204) or transmitter (course 2202) to accompany the measurement theories for a well-rounded class.

#### Topics

- Installation and Application Problems
- Configuration of Outputs / Alarms (If applicable)
- Use Diagnostic Features (If Applicable)
- Sensor Calibration & Maintenance
- Troubleshooting

### Roxar - Acoustic Sand Monitor - RX007 CEUs - 1.2

#### Overview

The Roxar Sand Monitor is a non-intrusive acoustic sand monitoring system that identifies in real-time sand production in any water, oil, gas or multiphase flow lines for onshore and offshore locations. This 1-day training course focuses on teaching the participants what valid and non-valid data are; provides knowledge on how to create reports from data received by the instrument in order to provide input to integrity managers to enable better decision-making. The course is available in two versions: SAM Server and Fieldwatch, depending on the system soft-ware that your installation is using to operate the instrumentation.

#### Topics

- Introduction to Sand Metering
  - Causes of Sand Production
  - Why Do we Need Sand Detection System?
  - Roxar Sand and Pig Detection System
  - System Enclosure, History; Challenge, Integration with Other Products
- Measurement Technology
  - How Do We Measure – Sand Interface
  - Sand Rate Calculation - Sand Detector
  - Product Optimization
- Operations
  - Software and General Set-Up; - System Overview
  - Configure Sensor Parameters
  - Process Data Interface: Flow Rate Input, Velocity Input, Choke Input, Well Test Data Interface
  - Alarm Settings Interface, Data Logging
  - Basic Interpretation: Basic Noise Estimation, Sand Production Estimation
  - Adv. Interpretation: Velocity in Signal Interpretation
  - Flow Regime Consideration

### Roxar - Acoustic Sand Monitor - RX007 – Continued...

- Maintenance
  - Detector Installation: Locations on Pipe, Temperature Considerations; - Wiring
  - Communication Digital Output, Analogue Output, Volt Free Contact, Lamp Output
  - Calibration: Factory Calibration, Background Noise Calibration, Automatic Background Noise Curve (ABA), Sand Noise Calibration
  - Sand Transport Capability Indicator
  - Sand Mass Correction (L)
  - Choke Calibration
  - Filtering Settings: Alpha and Beta Filtering of Raw Data, K-Factor
  - Preventative Maintenance: Visual Inspection and Routine Testing
  - Calibration Adjustment: Background Noise Calibration (Zero Calibration)
  - Sand Calibration, Hardware Maintenance: Checking Sensor Connections, Reinstalling or Replacing the Detector

### Roxar CorrLog Intrusive Corrosion Monitoring System - ROX008 CEUs - 1.2

#### Overview

Our intrusive corrosion monitor 1-day training course will provide your personnel with the knowledge of the Roxar intrusive corrosion monitoring system, providing understanding of the different system infrastructures, components and measurement principles. The course focuses on teaching the participants what valid and non-valid data are; provides knowledge on how to create reports from data received by the instrument in order to provide input to integrity managers to enable better decision-making. The course is available in two versions: MultiTrend and Fieldwatch, depending on the system software that your installation is using for operations of the instrumentation.

#### Topics

- Introduction to Corrosion Monitoring
  - Overview of Corrosion Issues
  - Why Corrosion Monitoring?
- Corrosion Control and Process Optimization

### Roxar CorrLog Intrusive Corrosion Monitoring System- ROX008 – Continued...

- Integrity Management and Safety
  - Basic Principles for Selecting Locations for Corrosion Monitoring
  - Overview of the Roxar Intrusive Corrosion Monitoring System
- Weight Loss Coupons, Electrical Resistance Probes, Linear Polarization Probes, Galvanic Probes
- Mechanical Accessories
  - Instrumentation
  - System Software
  - Integrated Flow Assurance Monitoring Systems
- Measurement Principles
  - Weight Loss Coupons
  - Electrical Resistance Probes
  - Linear Polarization Probes
  - Galvanic Probes
- Software Operations
  - Verification of the Software
  - Configuration and Installation Architecture
  - Instrument Specific Parameters
  - Raw Data Verification
  - Engineer Values
- Data Handling and Presentation
- Data Interpretation
- Reporting
  - Exporting Data
- Maintenance
  - Battery Replacement (Offline Systems Only)
  - System Health Check
- Replacing Interface Cards

### Roxar Field Signature Method- ROX010 CEUs - 1.2

#### Overview

Corrosion is a major cost in the oil and gas as well as other industries, and frequently being the reason for accidents and unplanned interruptions in production plans. Corrosion monitoring is thus important for verification of the assets integrity. Roxar's FSM (Field Signature Method) system is a non-intrusive system for monitoring internal corrosion in pipes, pipelines or vessels directly in the pipe wall. Our Non-Intrusive Corrosion Monitor 2-day training course will provide your personnel with the knowledge of the Roxar non-intrusive corrosion monitoring system, understanding of the different system infrastructures, components and measurement principles. The course focuses on teaching the participants what valid and non-valid data are; provides knowledge on how to create reports from data received by the instrument in order to provide input to integrity managers to enable better decision making. The course is available in two versions: MultiTrend and Fieldwatch, depending on the system software that your installation is using for operations of the instrumentation.

#### Topics

- Introduction
  - Overview of Corrosion Issues
  - Why Corrosion Monitoring?
- Corrosion Control and Process Optimization
- Integrity Management and Safety
  - Basic Principles for Selecting Locations for Corrosion Monitoring
  - Overview of the Roxar FSM System
- Mechanical Components
- Buried System
  - Instrumentation
  - System Software
  - System Infrastructure
  - Integrated Flow Assurance Monitoring Systems
- Measurement Principles
  - Field Signature Method
- Software Operations
  - Verification of the Software
  - Configuration and Installation Architecture
  - Instrument Specific Parameters
  - Raw Data Verification
  - Signature
  - Engineering Values
- Data Handling and Presentation
- Data Interpretation
- Reporting
  - Exporting Data
- Maintenance

### Roxar Field Signature Method - ROX010 – Continued...

- Battery Replacement (EX Version)
- System Health Checks

### Roxar Hydraulic Retrieval & Access Fitting System - ROX011 CEUs - 1.8

#### Overview

The objective of this course is to give the participant an overview of the Hydraulic Retrieval & Access Fitting System. The focus of this 1-day course is to bring awareness of working safely and efficiently with the tool and safe work practices. It will explain the design and operations of the tool and the fitting, and is recommended for anyone who will work with retrieval operations using our hydraulic retrieval system. Physical demonstrations with retrievers, service valves, and retractors on non-pressurized stands may be arranged by special request.

#### Topics

- Introduction
  - The Hydraulic Access Fitting and its Components
  - The Hydraulic Tool Retrieval and its Components
  - Different Variations of the Tool (PED/Non-PED)
- Theoretical Operation
  - Videos
  - Theoretical Run through the Operation
  - Understanding How the Tool Works
  - Safe Operation of the Tool
  - Troubleshooting and Maintenance
- Practical Operation
  - Practical Troubleshooting
  - Focus on Getting Comfortable using the Tool
  - Repeated Operations
  - Maintenance After Use
  - Practical Exam

### Roxar SandLog Intrusive Sand Monitoring System - ROX009 CEUs - 1.2

#### Overview

Our intrusive sand monitor 1-day training course will provide your personnel with the knowledge of the Roxar Sand Monitoring System, providing understanding of the different system infrastructures components and measurement principles. The course focuses on teaching the participants what valid and non-valid data is; provides knowledge on how to create reports from data received by the instrument in order to provide input to integrity managers to enable better decision making. The course is available in two versions: MultiTrend & Fieldwatch, depending on the system software that your installation is using for operations of the instrumentation.

#### Topics

- Introduction to Intrusive Sand Metering
  - Overview of Sand/Erosion Issues
  - Basic Principles for Selection Locations for Sand/ Erosion Monitoring
  - Erosion Control Integrity & Safety
  - Optimizing Flow Rates & Production
  - Overview of the Roxar Intrusive Sand/Erosion Monitoring System
- Mechanical Accessories
- Sand Erosion Probes
- Combined Sand Erosion & Corrosion Probe
  - Electrical Resistance Probes
  - Instrumentation
  - System Software
  - Integrated Flow Assurance Monitoring Systems
- Measurement Principles
  - Electrical Resistance Probes
- Sand Erosion Measurements
- Correlations with Sand Production
- Combined Sand Erosion and Corrosion Probe
- Software Operations
  - Verification of the Software
  - Configuration & Installation Architecture
  - Instrument Specific Parameters
  - Raw Data Verification
  - Engineer Values
- Data Handling and Presentation
- Data Interpretation
- Reporting
  - Exporting Data
- Maintenance
  - Battery Replacement (Offline Systems Only)
  - System Health Check
  - Replacing Interface Cards

### Roxar Watercut Meter - ROX006 CEUs - 1.2

#### Overview

The Roxar Watercut meter measures water in oil (0% to 100%) and is used in process control on test separators, fiscal metering, on- and offloading, export metering, desalting in refineries, two phase flow metering. The Roxar Watercut meter uses a unique and patented microwave resonance technology to measure the permittivity of an oil/water mixture with an extremely high level of accuracy and sensitivity. The aim of this 1-day course is to enable participants to take full advantage of the meter in real applications. Upon completion of the course participants should be able to efficiently run the instrument on their own, including delivering on-site quality reliable data, do normal routine maintenance, fault finding and troubleshooting.

#### Topics

- Introduction to Water Cut Metering and Technology
  - Why Measure Water Cut?
  - Water Cut Metering Challenges
  - Water Cut Metering Requirements
  - Technology for Water Cut Measurement
- Measurement Technology
  - How Do We Measure Water Cut
  - Installation
  - Microwave Signal Path
  - Entrapment of Microwaves in a Pipe
  - Microwave Resonance
  - Permittivity of Oil and Water
  - Water Continuous and Oil Continuous Phase
  - The Tables of Water Cut Made from the First Meter
  - The Production of the Meters to Fit the Model of the First Meter
  - The Production Sequence in a Meter
  - Measurement Uncertainty and Initial Explanation
- Operations
  - Connecting to the Meter
  - Software Operations: Entering the Meter, Configuration
  - Measurement
  - Inline Calibration of the Meter
  - Measurement Uncertainty
  - Practical Exercises on Meter Electronics
- Maintenance
  - Overview of Recommended Maintenance
  - Turning Diagnostics and Logging of Hyper Terminal
  -

### Roxar Watercut Meter - ROX006 – Continued...

- Taking a 50dB Plot of Microwave Electronics
- Common Error Messages
- Sending Diagnostic Data to Roxar for Analysis and Filing
- Download New Code for a Meter
- Erasing Battery Backed RAM in a Meter
- Troubleshooting the Temperature Transmitter
- Practical Exercises

### Roxar Subsea Wetgas Meter- ROX005 CEUs - 1.2

#### Overview

The Roxar Subsea Wetgas meter is a unique instrument allowing accurate measurement of hydrocarbon flow rates and water production with a very compact mechanical solution. The aim of this 1-day training is to provide the participants with in-depth knowledge of instrument operations which enable participants to take full advantage of the meter in real applications. Course participants will be taught the intricacies of the meter and measurement technology, understanding of the data and the measurement principles will allow better decision making when it comes to reservoir management and optimizing the production process.

#### Topics

- Introduction to Wetgas
  - Introduction
  - Wet Gas
  - Why Measure Water?
  - Multiphase Flow
  - Flow Conditions
  - Ranges and Specifications
  - Installation Examples
- Mechanical Specifications
  - Material Overview
  - Design Standards
  - SWGM Components
  - Cathodic Protection and HISC
  - Insulation and Coating
  - Testing
- Measurement Technology
  - Overview of the Measurement System
  - The Principle of Operation
  - Direct Measurement and Required Inputs
  - Fraction Calculations
  - Formation Water Detection
  - Calculation Modes
  - Redundancy
- Operations and Maintenance
  - Pre-commissioning Phases
  - Commissioning and Start Up
  - Communication
  - Roxar SWGM Console
  - Meter Operation
  - Alarms and Warnings

### Roxar Subsea Wetgas Meter- ROX005 – Continued...

- Calibration (Describe All Alternatives)
- Maintenance

### Roxar - Fieldwatch - ROX012 CEU – 0.7

#### Overview

Roxar Fieldwatch enables the intelligent oilfield and helps the users to improve work processes, optimize production and in the end maximize reservoir recovery. Roxar Fieldwatch collects, monitors, visualizes and analyzes data from a range of sensors and instruments to provide operators with a complete picture of the reservoir and the production system. It also provides data input to reservoir and production engineers when they make reservoir management decisions relating to metering, production allocation or choke settings. The end result is a more intelligent reservoir and increased production. Give participants an overview of the software, ensuring users are familiar with navigation of the software and menus.

### Roxar 2600 Multiphase Flow Meter – Introduction – ROX013 CEUs – 0

#### Overview

This 1-day training course provides the participants with an understanding of the multiphase flow, components and measurement principles of the instrument.

Upon completion of the course participants should have a good understanding of the theoretics of the Roxar 2600 MPFM including multiphase flow, components and measurement principles of the instrument.

For hands on training please refer to courses ROX014 and ROX015.

#### Topics

- Introduction to Multiphase Flow
- Introduction to Multiphase Metering
- Typical Installations and applications
- Mechanical Design
- Installation requirements
- Measurement Technology
- Measurement Uncertainty
- Communication

#### Audience

Technicians, Operators, Maintenance personnel

#### Prerequisites

Some experience with instrumentation would be helpful. In order to gain the maximum benefit of the course we recommend that each participant gets acquainted with Handbook of Multiphase Metering available for download on [www.nfogm.no](http://www.nfogm.no) (under documents section) or completes an online course on the same website under NFOGM Metering School.



### Roxar 2600 Multiphase Flow Meter – Intermediate – ROX014 CEUs – 0

#### Overview

This 3-day training ensures your instrument technicians and engineers know how to correctly install, configure, startup and troubleshoot your Roxar 2600 MPFM.

We offer in-depth product training either at a local Emerson office, at business locations in your area or at your own site.

The Roxar 2600 MPFM training will enable you to:

- Properly install meters according to specifications
- Commission and start-up new meters
- Troubleshoot meter problems

#### Topics

- System Overview
- Installation of Service Console
- Main Screen
- File handling
- View
- Options
- Fluid
- Configuration of data logging
- Service Menu on the Service Console
- Alarm recognition and Troubleshooting
- PVTx
- Installation of meter into pipeline
- Pressure test & drainage
- Verification of Mechanical design
- Gamma source installation & calibration
- Wiring & Grounding
- Commissioning
- Fluid Sampling
- Validation of start-up data
- Communication through the SCADA network
- Voltage checks
- Configuration of data logging

#### Audience

Technicians, engineers

#### Prerequisites

Completion of Module 1 ROX013 is required to attend the training

### Roxar 2600 Multiphase Flow Meter – Advanced – ROX015 CEUs – 0

#### Overview

This 2-day training ensures your instrument technicians and engineers know how to improve reliability of the MPFM and get an overview of required maintenance activities. Our certified Instructors share their valuable experience from working in field and lead students through extensive hands-on exercises using the latest configuration tools. This maximizes the training effectiveness and enables attendees to quickly apply their new skills and knowledge in their job.

We offer in-depth product training either at a local Emerson office, at business locations in your area or at your own site.

The Roxar 2600 MPFM training will enable you to:

- Improve instrument lifecycle
- Reduce downtime and cost
- Increase reliability and availability

#### Topics

- Visual inspection
- Verification of valves opening
- Declogging of MVT pressure lines
- Maintenance on electronics enclosure
- Communication status
- Flow computer SW upgrade
- Configuration of data logging
- Radiation Level Check
- Gamma System Calibration
- Zero point calibration of DP & P Transmitters
- Well test verification
- Replacement of Flow Computer parts
- Replacement of parts
  - Field Electronics
  - gamma system
  - temperature sensor
  - Venturi
  - Replacement of wiring
- Meter cleaning
- Re-commissioning of meter upon relocation

#### Audience

Technicians, engineers

#### Prerequisites

Completion of Module 1 ROX013 and Module 2 ROX014 is required to attend the training

### Roxar 2600 Multiphase Flow Meter - ROX016 CEUs – 0

#### Overview

The objective of the Roxar MPFM2600 2-day course is to provide the participant with an understanding of the Roxar 2600 multiphase meter components and measurement principles. The course focuses on providing the participants with detailed understanding of the set up and configuration; calibration data, reference fluid parameter set up and operation of the meter. The course will cover interpretation and correlation of MPFM parameters versus influences of process conditions. Understanding the data is the key in order to make the right decisions for reservoir management. (This training course includes Hands on Training with an offline actual meter).

#### Topics

- Introduction to Multiphase Metering
- Single Phase Metering/Multiphase Metering
- Flow Regimes
- Roxar's Experience in Multiphase Metering
- Roxar MPFM2600
- Mechanical Design
- Mechanical Specifications
- Installation and Commissioning Instructions
- Measurement Technology
- Overview of the Measurement System
- The Principle of Operation (Phase Fraction Measurement, the Gamma Densitometer, Velocity Measurement, PVT Tables, Phase Slip, Static Properties)
- Software Operations
- Overview of Roxar MPFM Operation System
- Installation and Start Up of the Service Console
- Software Operations: Practical Information on How to Access and Save Parameter Files, Logging and Retrieving data, Well Test Options
- Maintenance
- Overview of the Mechanical System
- Maintenance
- Gamma System
- Electrical System
- Calibration
- Replacement of Parts
- PVT
- What is PVTx
- Fluid Analysis: Sampling, Compositional Data
- Tempest PVTx
- Import Tables
- Parameter Save and Download; Diagnostics; Troubleshooting

#### Audience

Technical personnel operationally involved with Roxar Multiphase Flow Meters.

#### Prerequisites

Some experience with instrumentation would be helpful. In order to gain the maximum benefit of the course we recommend that each participant gets acquainted with Handbook of Multiphase



### RS3 Configuration - Advanced – 3500 CEUs - 2.1

#### Overview

Advanced Control Block configuration training for those whose needs go beyond cascade or ratio control and straightforward Interlock logic.

#### Topics

- 3500-1 Introduction and Overview
- 3500-2 Configuring Control Blocks for High Level Orchestration
- 3500-3 Optimizing Complex Logic Functions
- 3500-4 Optimizing Block Data Transfer

#### Prerequisite

Curriculum 3100 Introduction to RS3

### RS3 Hardware & Maintenance – 3200 CEUs - 3.5

#### Overview

Students entering this curriculum should have a general electronics background, and should know how to use electronics test equipment such as a multimeter & current source.

#### Topics

- 3200-10 RS3 Hardware Overview
- 3200-20 Power Supplies/Power Distribution
- 3200-70 The PeerWay
- 3200-30 Console Electronics
- 3200-31 CRT Displays
- 3200-32 Multitube Command Consoles
- 3200-40 Control Files -Coordinator Processor IV
- 3200-53 Overview of the I/O Subsystem
- 3200-50 Analog I/O Hardware
- 3200-51 Discrete I/O Hardware
- 3200-52 Contact I/O Hardware
- 3200-54 Low-Level Input Multiplexer
- 3200-56 PLC Interface
- 3200-57 Multipoint Analog Input/Output

#### Audience

The 3200 curriculum is designed for technicians and engineers who are responsible for installing, starting up, or maintaining a RS3 installation.

#### Prerequisites

3100: modules 1, 2, 3 & 4

### RS3 - Introduction – 3100 CEUs - 3.5

#### Overview

This curriculum provides a starting point for all engineers, technicians and other personnel who will configure, install, or maintain any part of a RS3 Distributed Control System. It may meet all the needs of those configuring control systems for continuous processes requiring nothing more complex than cascade or ratio control, simple interlocks or motor controls. For others, 3100 modules serve as prerequisites for modules in the 3200, 3500 or 3600 curricula. This curriculum can provide a basic understanding of RS3 for managers and others whose success depends on the system but who will not work with it directly.

#### Topics

- 3100-1 Developing Basic Operating Skills Using the RS3 MTCC Console
- 3100-2 System Hardware and Architecture
- 3100-3 Configuring Basic Control Loops
- 3100-4 Configuring Trends, Reports, Alarms/ Console Configuration- RS3 MTCC Console
- 3100-5 Configuring Logic Functions/Displays
- 3100-6 Configuring Process Graphic Displays Using the RS3 MTCC Console
- 3100-7 Configuring Cascade/Ratio Loops

#### Audience

This curriculum provides a starting point for all engineers, technicians and other personnel who will configure, install, or maintain any part of a RS3 Distributed Control System.

#### Prerequisites

With the retirement of the RS3 product line in 2013, these courses can only be assured to customers with a Sustain Support Agreement. A Sustain Support Agreement can be customized to meet your needs for future support-taking into consideration your onsite resources and schedule for modernization. Please contact your local office to learn more about Sustain Support.

### RS3 Process Operation– 3400 CEUs - 1.8

#### Overview

Training can be tailored to either a continuous or a batch process. The 3400 modules help the student learn how to analyze process conditions and make process adjustments, with confidence and without hesitation. Training activities help the student develop keyboard dexterity

### RS3 - Process Operation – 3400 – Continued...

through repetition of routine procedures under increasingly challenging conditions. Qualification exercises require each student to demonstrate an adequate skill level before proceeding to the next training activity or module.

#### Topics

For MTCC Consoles:

- 3400-1 Basic Operating Displays and Adjustments Using the MTCC Console
- 3400-2 Operating Cascade and Ratio Loops Using the MTCC Console
- 3400-4 Operating Batch Processes Using ABC Batch Software through the MTCC Console (Batch Only!)

For ROS Consoles:

- 3400-11 Basic Operating Displays and Adjustments Using the RS3 Operator Station
- 3400-12 Operating Cascade and Ratio Loops Using the RS3 Operator Station
- 3400-14 Operating Batch Processes Using ABC Batch Software Through the RS3 Operator Station (Batch Only!)

#### Time Required

Standard Operator Training (non-batch) - 12 hours. Including batch - 20 hours.

#### Audience

The 3400 curriculum is designed for plant operators and supervisors who are responsible for day-to-day process operation.

### RS3 Process Operation Configuring RS3 Control for Batch Processes – 3600 CEUs - 3.5

#### Topics

- 3600-10 Introduction to ABC Batch Recipe
- 3600-11 Intro. to RBL Language/Scripts
- 3600-12 Configuring Batch Tasks
- 3600-2 Displays, Alarms, & Reports
- 3600-3 Exception Management in a Task Environment
- 3600-4 Batch Data Transfer
- 3600-5 Advanced Task Organization

Time Required - 1 Week

#### Audience

The 3600 modules are designed for engineers who must configure/support a batch process control system using RS3 ABC Batch software.

#### Prerequisite

Curriculum 3100, Introduction to RS3

**Shafer Rotary Vane Maintenance & Field Service – Introduction - VA109**  
**CEUs – 1.6**

**Overview**

This 2-day course presents a fundamental overview of the construction, assembly, hardware, and configuration of Shafer actuators. Students attending this program will demonstrate an ability to identify actuators, hardware, components, and assemblies. All students will demonstrate the ability to setup, check, and verify operation of various actuator configurations using appropriate methods shown in the class.

**Topics**

- Basic design and power transmission fundamentals
- Component tear down and rebuild
- Hydraulic schematics
- Installation and Commissioning
- Modification kits

**Prerequisite**

Students should have a minimum of one year field service experience and working knowledge of hydraulic actuators.

## Syncade Administration – 7087 CEUs – 1.4

### Overview

This 2-day Syncade Administration Course will provide an overview of Syncade administration functions, tools and practices to successfully maintain the MES platform. Students will engage in lectures reinforced by practical hands-on labs.

### Topics

- Syncade System Requirements
- User Accounts
- Syncade Installation
- Network Load Balancing
- Service Controller (Consumer and Scheduler)
- Integration Types
- Internet Information Services
- Errors Logging
- Administration Tool
- Hotfix Installation
- SQL discussion
- Reporting
- Troubleshooting Tips
- System Management Recommendations

### Audience

This course is designed for System Administration personnel responsible for administering and successfully managing Syncade MES platforms.

### Prerequisites

7080 - Syncade Overview

## Syncade Administration - Virtual - 7087V CEUs – 1.4



### Overview

This 2-day Virtual Syncade Administration Course will provide an overview of Syncade administration functions, tools and practices to successfully maintain the MES platform. Students will engage in lectures reinforced by practical hands-on labs.

### Topics

- Syncade System Requirements
- User Accounts
- Syncade Installation
- Network Load Balancing
- Service Controller (Consumer and Scheduler)
- Integration Types
- Internet Information Services
- Errors Logging
- Administration Tool
- Hotfix Installation
- SQL discussion
- Reporting
- Troubleshooting Tips
- System Management Recommendations

## Syncade Document Control & Archiving – 7081

### CEUs – 1.4

### Overview

This 2-day class provides the user with the necessary skills to set up, configure and maintain the DCA module in Syncade™. Students will be taught repository setup and administration settings, how to add documents to a user configured repository structure using manual or automated techniques, manually move documents through the promotion model as well as editing existing documents and making them available to the production cycle. Users will configure and use the Change Request feature within DCA to move documents through the promotion model. Change request types and workflows will be created and users assigned to the roles in the steps to automate the document promotion process. Document packages will also be taught in this class. Users will create package classes that will be used to create a print package for a production run.

### Topics

- DCA Overview
- DCA User Interface
- Repository Creation, Configuration and Use
- Document Types
- Configured Properties
- Creating Document Properties
- Adding Documents — Manual /Autoloader
- Document Life Cycle
- Document Change Control
- Change Request User Interface
- Change Request Life Cycle
- Change Request Types
- Change Request Workflows
- Creating Change Requests
- Review and Approval Processes
- Document Packages Overview
- Packages User Interface
- Package Classes

## Syncade Document Control & Archiving - Virtual - 7081V CEUs – 1.4



### Overview

This 2-day class provides the user with the necessary skills to set up, configure and maintain the DCA module in Syncade™. Students will be taught repository setup and administration settings, how to add documents to a user configured repository structure using manual or automated techniques, manually move documents through the promotion model as well as editing existing documents and making them available to the production cycle. Users will configure and use the Change Request feature within DCA to move documents through the promotion model. Change request types and workflows will be created and users assigned to the roles in the steps to automate the document promotion process. Document packages will also be taught in this class. Users will create package classes that will be used to create a print package for a production run.

### Topics

- DCA Overview
- DCA User Interface
- Repository Creation, Configuration and Use
- Document Types
- Configured Properties
- Creating Document Properties
- Adding Documents — Manual /Autoloader
- Document Life Cycle
- Document Change Control
- Change Request User Interface
- Change Request Life Cycle
- Change Request Types
- Change Request Workflows
- Creating Change Requests
- Review and Approval Processes
- Document Packages Overview
- Packages User Interface
- Package Classes

### Syncade Overview – 7080 CEUs - 1.4

#### Overview

This 2-day class provides an overview of the Syncade™ applications and their use within a Manufacturing Execution System (MES) environment. The Syncade applications handle tasks that fit between the process control system environment, such as DeltaV™, and corporate Enterprise Resource Planning (ERP) systems, such as SAP. Each module in Syncade will be covered briefly to provide the user with a basic understanding of the module, its functionality and how it fits into the overall MES functional layer. Integration methods and implementation techniques are not part of this class.

#### Topics

- Manufacturing Execution Systems (MES)
- Document Control and Authoring
- Security Basics
- Portal
- Training and Development
- Equipment Tracking
- Materials Management
- Inventory Management
- Recipe Authoring
- Order Management
- Weigh and Dispense

### Syncade Overview - Virtual - 7080V CEUs - 1.4



#### Overview

This 2-day class provides an overview of the Syncade™ applications and their use within a Manufacturing Execution System (MES) environment. The Syncade applications handle tasks that fit between the process control system environment, such as DeltaV™, and corporate Enterprise Resource Planning (ERP) systems, such as SAP. Each module in Syncade will be covered briefly to provide the user with a basic understanding of the module, its functionality and how it fits into the overall MES functional layer. Integration methods and implementation techniques are not part of this class.

#### Topics

- Manufacturing Execution Systems (MES)
- Document Control and Authoring
- Security Basics
- Portal
- Training and Development
- Equipment Tracking
- Materials Management
- Inventory Management
- Recipe Authoring
- Order Management
- Weigh and Dispense

### Syncade Equipment Tracking - Virtual - 7083V CEUs - 1.4



#### Overview

This 2-day class will provide the user with the necessary skills to create, configure and maintain equipment used in the production process. Users will configure equipment classes and equipment that will provide a solution for managing equipment use, maintenance and calibration information. Events will be set upon the equipment class that define actions that can be performed, or need to be performed, on equipment created from the equipment class. Rules and groups will be configured to assist in implementing controls on equipment and when certain events need to occur. Schedules will be created to set up periodic preventive maintenance and work orders will be created to cover the unscheduled activities that may be needed to fully utilize production equipment.

#### Topics

- ET Overview
- Create Equipment Classes
- Define Calibration Targets
- Add Custom Properties
- Create Events and Event State Matrix
- Create Rules and Groups
- Material and Labor with Events
- Event Scheduling
- Create Equipment
- Integrating Documents and Skills
- Performing Events
- Work Orders

### Syncade Materials, Inventory & Order Management – 7084 CEUs - 2.1

#### Overview

This 3-day class will provide the user with the necessary skills to create and manage all types of materials as they flow into, through and out of the production environment during order execution. Users will create material masters to define the material characteristics, create inventory, create and execute orders, allocate materials, create material samples, track lots and containers and perform weigh and dispense activities.

#### Topics

- Material/Inventory Management Overview
- OM Overview
- Material Masters
- Material Properties
- Quality Statuses
- Order Creation and Execution
- Material Allocations
- Weigh and Dispense
- Trusted Dispensing
- Sampling
- Purchasing and Receiving
- Lot and Container Actions
- Physical Inventory
- Genealogy
- Inventory Adjustments

### Syncade Materials, Inventory & Order Management - Virtual - 7084V CEUs - 2.1



#### Overview

This 3-day class will provide the user with the necessary skills to create and manage all types of materials as they flow into, through and out of the production environment during order execution. Users will create material masters to define the material characteristics, create inventory, create and execute orders, allocate materials, create material samples, track lots and containers and perform weigh and dispense activities.

#### Topics

- Material/Inventory Management Overview
- OM Overview
- Material Masters
- Material Properties
- Quality Statuses
- Order Creation and Execution
- Material Allocations
- Weigh and Dispense
- Trusted Dispensing
- Sampling
- Purchasing and Receiving
- Lot and Container Actions
- Physical Inventory
- Genealogy
- Inventory Adjustments

### Syncade Overview - 7080B CEUs - 1.8



#### Overview

This 2-day class provides an overview of the Syncade applications and their use within a Manufacturing Execution System (MES) environment. The Syncade applications handle tasks that fit between the process control system environment, such as DeltaV™, and corporate Enterprise Resource Planning (ERP) systems, such as SAP. Each module in Syncade will be covered briefly to provide the user with a basic understanding of the module, its functionality and how it fits into the overall MES functional layer. Integration methods and implementation techniques are not part of this class. This course is online, on-demand and includes:

Recorded lectures, workshop demonstrations, and instructions available for 6 months after course enrollment, Access to a dedicated student Syncade Workstation in the cloud to perform hands-on workshops available from 6 months or 15 hours of workstation run time (whichever occurs first). Requires a high-speed internet (DSL minimum and HTML 5 compliant browser (prefer Chrome) Student Workbook sent to students.

#### Topics

- Manufacturing Execution Systems (MES)
- Document Control and Authoring
- Security Basics
- Portal
- Training and Development
- Equipment Tracking
- Materials Management
- Inventory Management
- Recipe Authoring
- Order Management

### Syncade Recipe Authoring - 7095B CEUs - 2.1



#### Overview

This 3-day class will provide the user with the necessary skills to configure version 4.3 recipes. Users will learn to configure and execute manual, automation, and integrated recipes using Syncade™ and DeltaV. Recipes will be taken from the configuration stage, through execution, and into the order completed state. This process will teach users how a complete batch record is made.

This course is online, on-demand and includes: Recorded lectures, workshop demonstrations, and instructions available for 6 months after course enrollment, Access to a dedicated student Syncade Workstation in the cloud to perform hands-on workshops available from 6 months or 15 hours of workstation run time (whichever occurs first). Requires a high speed internet (DSL minimum and HTML 5 compliant browser (prefer Chrome) Student Workbook sent to students

#### Topics:

- Recipe Authoring (RA) Overview
- RA Application
- Manual and Automation Recipe Hierarchy
- Work Instructions and Parameter Types
- Operations, Unit Procedures and Procedure Creation
- RA Simulator
- Process Segments
- Master Recipes
- Order Execution
- Parameter Referral and Deferral
- Reference Groups
- Formula Creation/Selection
- Behaviors
- DeltaV Recipes
- Integrated Type 2 and 3 Recipes

### Syncade Recipe Authoring - Virtual - 7095V CEUs - 2.1



#### Overview

This 3-day class will provide the user with the necessary skills to configure version 4 recipes for Syncade™ execution. Users will learn to configure manual recipes, DeltaV recipes and recipes that integrate the Syncade and DeltaV into a complete cohesive batch record.

#### Topics

- Recipe Authoring (RA) Overview
- RA Application
- Manual and Automation Recipe Hierarchy
- Work Instructions and Parameter Types
- Operations, Unit Procedures and Procedure Creation
- RA Simulator
- Process Segments
- Master Recipes
- Order Execution
- Parameter Referral and Deferral
- Reference Groups
- Formula Creation/Selection
- Behaviors
- DeltaV Recipes
- Integrated Type 2 and 3 Recipes

Note: Detailed application classes available to customers that have purchased Syncade.



### Syncade Configure Training & Development Module – 7082

#### CEUs - 0.7

#### Overview

This 1-day class will provide the user with the necessary skills to configure the Training and Development module to successfully ensure the workforce is up to date with job related skill sets. Users will configure the tasks and skill sets necessary for an individual to complete a job function as well as maintain those skills over time. Users will configure an organizational structure that will be used to define departments and positions and assign skills to those positions that will set the requirements for a person holding that position. Courses will be created that will teach the tasks required to fill a position in the organization.

Users will also schedule classes and learn how to enroll themselves and others using the training and requirement planners in the TD module.

Users will also be taught how to set up the notification processes within the Syncade administration menus.

#### Topics

- TD Overview
- Defining the Organizational Structure
- Creating Tasks
- Creating Skills and Assigning Tasks
- Certification Methods
- Setting Up Training Classes
- Creating Job Requirements
- Integrating TD with Other Syncade Modules
- Maintaining Necessary Job-Related Skills Administration Notification Processes

### Syncade Configure Training & Development Module – Virtual - 7082V

#### CEUs - 0.7

#### Overview



This 1-day class will provide the user with the necessary skills to configure the Training and Development module to successfully ensure the workforce is up to date with job related skill sets. Users will configure the tasks and skill sets necessary for an individual to complete a job function as well as maintain those skills over time. Users will configure an organizational structure that will be used to define departments and positions and assign skills to those positions that will set the requirements for a person holding that position. Courses will be created that will teach the tasks required to fill a position in the organization.

Users will also schedule classes and learn how to enroll themselves and others using the training and requirement planners in the TD module.

Users will also be taught how to set up the notification processes within the Syncade administration menus.

### 7082V – Continued...

#### Topics

- TD Overview
- Defining the Organizational Structure
- Creating Tasks
- Creating Skills and Assigning Tasks
- Certification Methods
- Setting Up Training Classes
- Creating Job Requirements
- Integrating TD with Other Syncade Modules
- Maintaining Necessary Job-Related Skills Administration Notification Processes

### Syncade Administration - 7087

#### CEUs: 1.4

#### Overview

This 2-day Syncade™ Administration Course will provide an overview of Syncade administration functions, tools and practices to successfully maintain the MES platform. Students will engage in lectures reinforced by practical hands-on labs.

#### Topics

- Syncade System Requirements
- User Accounts
- Syncade Installation
- Network Load Balancing
- Service Controller (Consumer and Scheduler)
- Integration Types
- Internet Information Services
- Errors Logging
- Administration Tool
- Hotfix Installation
- SQL discussion
- Reporting
- Troubleshooting Tips
- System Management
- Recommendations

#### Audience

This course is designed for System Administration personnel responsible for administering and successfully managing Syncade MES platforms.

#### Prerequisites

- 7080 - Syncade Overview

### Syncade Administration – Virtual - 7087V

#### CEUs: 1.4



#### Overview

This 2-day Syncade™ Administration Course will provide an overview of Syncade administration functions, tools and practices to successfully maintain the MES platform. Students will engage in lectures reinforced by practical hands-on labs.

#### Topics

- Syncade System Requirements
- User Accounts
- Syncade Installation
- Network Load Balancing
- Service Controller (Consumer and Scheduler)
- Integration Types
- Internet Information Services

### 7087V – Continued...

- Errors Logging
- Administration Tool
- Hotfix Installation
- SQL discussion
- Reporting
- Troubleshooting Tips
- System Management
- Recommendations

### Syncade Operations Implementation – 7180

#### CEU'S: 3.2

#### Overview

This 4.5-day course aims to equip the students to understand where Syncade fits on a production environment. This includes the applications of different modules that Syncade has in a manufacturing environment. These modules are Security & Audit (SA), Document Control & Archiving (DCA), Training & Development (TD), Equipment Tracking (ET), Materials and Inventory Management (MM & IM), Order Management (OM), Weigh & Dispense (WD), and Quality Review Manager (QRM). This course also allows the students to build a basic recipe to be created via Recipe Authoring (RA) application and simulate it via Workflow (WF).

#### Topics

1. Manufacturing Operations Management
2. Security and Audit (SA)
3. Portal
4. Document Control & Archiving (DCA)
5. Training & Development (TD)
6. Process Simulation
7. Equipment Tracking (ET)
8. Materials Management (MM)
9. Inventory Management (IM)
10. Recipe Authoring (RA) Overview
11. Enumeration Sets
12. Work Instruction (WI)
13. RA Database Items
14. Operations (OP), Unit Procedures (UP), Procedures (PRC)
15. Process Segment (PS)
16. Master Recipe (MR)
17. Order Management (OM)
18. Weigh & Dispense (WD)
19. Workflow (WF)
20. Manufacturing and Quality Review (MR/QRM)

#### Audience

Engineers and IT professional who are new to Syncade and will be involved in usage and configuration of Syncade modules.

#### Prerequisites

None

### Syncade Operations Implementation – 7180

CEU'S: 3.2



#### Overview

This 4.5-day course aims to equip the students to understand where Syncade fits on a production environment. This includes the applications of different modules that Syncade has in a manufacturing environment. These modules are Security & Audit (SA), Document Control & Archiving (DCA), Training & Development (TD), Equipment Tracking (ET), Materials and Inventory Management (MM & IM), Order Management (OM), Weigh & Dispense (WD), and Quality Review Manager (QRM). This course also allows the students to build a basic recipe to be created via Recipe Authoring (RA) application and simulate it via Workflow (WF).

#### Topics

1. Manufacturing Operations Management
2. Security and Audit (SA)
3. Portal
4. Document Control & Archiving (DCA)
5. Training & Development (TD)
6. Process Simulation
7. Equipment Tracking (ET)
8. Materials Management (MM)
9. Inventory Management (IM)
10. Recipe Authoring (RA) Overview
11. Enumeration Sets
12. Work Instruction (WI)
13. RA Database Items
14. Operations (OP), Unit Procedures (UP), Procedures (PRC)
15. Process Segment (PS)
16. Master Recipe (MR)
17. Order Management (OM)
18. Weigh & Dispense (WD)
19. Workflow (WF)
20. Manufacturing and Quality Review (MR/QRM)

### Syncade Recipe Authoring Principles - 7181

CEU'S: 2.8

#### Overview

A 4-day intensive recipe authoring course, which focuses on how users can effectively write recipes in Syncade Recipe Authoring application using different strategies. These may include combination of principles in defining the work instruction and its parameters, configuring effective recipe steps pathways, automating tasks through behaviors, and understanding parameter data links implementation. Other recipe authoring functions are also discussed with respect to its formula and recipe hierarchy definitions. Supplementary recipe authoring tools, which includes RA Behavior Editor and Resource Editor, will also be discussed. An overview on DeltaV-Syncade integration options will also be explored.

### 7181 – Continued...

#### Topics

1. Batch Process Overview
2. Defining the Batch Process
3. Configuring Work Instructions
4. Recipe Steps Pathway
5. Behaviors
6. Parameter Data Link
7. Formula
8. Resource Editor
9. Configuring Recipes
10. RA Database Update
11. DeltaV Recipes
12. Integrated Recipes Overview

#### Audience

Engineers and IT professionals who will be involved in authoring and validating Syncade recipes.

#### Prerequisites

7180 Syncade Operations Implementation

### Syncade Recipe Authoring Principles – Virtual - 7181V

CEU'S: 2.8



#### Overview

A 4-day intensive recipe authoring course, which focuses on how users can effectively write recipes in Syncade Recipe Authoring application using different strategies. These may include combination of principles in defining the work instruction and its parameters, configuring effective recipe steps pathways, automating tasks through behaviors, and understanding parameter data links implementation. Other recipe authoring functions are also discussed with respect to its formula and recipe hierarchy definitions. Supplementary recipe authoring tools, which includes RA Behavior Editor and Resource Editor, will also be discussed. An overview on DeltaV-Syncade integration options will also be explored.

#### Topics

1. Batch Process Overview
2. Defining the Batch Process
3. Configuring Work Instructions
4. Recipe Steps Pathway
5. Behaviors
6. Parameter Data Link
7. Formula
8. Resource Editor
9. Configuring Recipes
10. RA Database Update
11. DeltaV Recipes
12. Integrated Recipes Overview

### Syncade Quality Review Manager - Virtual - 7182V

CEU'S: 2.1



#### Overview

This course aims to equip students how to effectively configure and operate manufacturing review via review-by-exception methodology using the Quality Review Manager (QRM) of Syncade Operations suite. This course discusses QRM settings and exception generation methodologies with hands on workshop to facilitate learning. Exception reviews, resolution, and manufacturing review through the QRM will also be explored. This course allows the students to see the entire review-by-exception approach of closing an order.

#### Topics

1. Quality Review Manager Overview
2. QRM Administration
3. General Settings
4. Severities
5. Resolutions
6. Exception Types
7. Perspectives
8. Email Templates
9. Subscriptions
10. Manufacturing Review
11. Syncade Exception Triggers
12. Automation Exception Triggers
13. Quality Review Manager Operations

#### Audience

MES Engineers, Process Engineers, Business Analyst, System Administration, Quality and Validation Engineers

#### Prerequisites

7181 (Recipe Authoring Principles)

### Syncade Equipment Management - Virtual - 7183V CEU'S: 2.1



#### Overview

This 3-day course will provide the user with the necessary skills to create, configure and maintain equipment used in the production process. Users will configure equipment classes and equipment that will provide a solution for managing equipment use, maintenance and calibration information. Events will be set upon the equipment class that define actions that can be performed, or need to be performed, on equipment created from the equipment class. Rules and groups will be configured to assist in implementing controls on equipment and when certain events need to occur. Schedules will be created to set up periodic preventive maintenance and work orders will be created to cover the unscheduled activities that may be needed to fully utilize production equipment. Recipes will be created to manage equipment hygienic, assembly, and usage states using default behaviors.

#### Topics

1. Equipment Management Overview
2. Equipment Class
3. Equipment Instance
4. Performing Events
5. Groups & Rules
6. Container Contents
7. Parameter, Materials, Labor, & References
8. Equipment Management Recipes
9. Equipment Workflow
10. Calibration
11. Work Order
12. Equipment Tracking Administration

#### Audience

MES Engineers, Recipe Authors, Process Engineers, and Quality Engineer

#### Prerequisites

7181 (Recipe Authoring Principles)

### Syncade Suite Operations - Virtual - 7184V CEU'S: 2.1



#### Overview

This course is for operators, supervisors, and managers responsible for fulfilling manufacturing activities using Syncade Operations.

This 2.5-day course uses lectures and hands-on workshops to provide an in-depth overview on operating the Syncade Operations modules. Activities that will be explored on a specific Syncade module in this course are as follows:

- Viewing effective documents (DCA)
- Training self-certification (TD)
- Perform equipment events and launch equipment workflows (ET)
- Understand basic batch terminology
- Understand order lifecycle and performing electronic workflows (OM, WD, and WF)

### 7184V – Continued...

•Respond to batch exceptions and generating batch reports (QRM)

#### Topics

1. Operations Management
2. Documents and Trainings
3. Simulated Process
4. Equipment Management
5. Materials and Inventory Management
6. Recipe Overview
7. Order Management and Execution
8. Weigh & Dispense
9. Workflows
10. Manufacturing Review
11. Quality Review Manager
12. Syncade Portal

#### Audience

Production personnel especially operators, supervisors, managers, or quality engineer.

#### Prerequisites

None

### Syncade Manufacturing Management - Virtual - 7185V CEU'S: 2.8



#### Overview

This class will provide the user with the necessary skills to create and manage all types of materials as they flow into, through and out of the production environment during order execution. Users will create material masters to define the material characteristics, create inventory, create and execute orders, allocate materials, create material samples, track lots and containers and perform weigh and dispense activities. Recipes will also be created to accomplish these activities using Emerson standard behaviors.

#### Topics

1. Manufacturing Management Overview
2. Materials Management
3. Inventory Management
4. Lots and Containers
5. Order Management
6. Creating Orders
7. Material Allocation
8. Material Dispensing
9. Trusted Dispensing
10. Consuming Inventory
11. WD Equipment Recipes
12. Material Handling Recipes
13. Manufacturing and Quality Review
14. Manufacturing Administration
15. Materials Transaction

#### Prerequisites

7181 - Syncade Recipe Authoring Principles

### Syncade - Recipe Authoring - Advanced - Virtual - 7186V CEU'S: 2.8



#### Overview

This course aims to equip advanced users who are already familiar with elementary principles of creating recipes using the Syncade Recipe Authoring (RA) application and its interaction with other Syncade modules by building even more complex recipes. These complex recipes are designed to work with other systems, such as DeltaV. The recipe to be developed in this course explores different integration approach with DeltaV recipes such as early binding and late binding recipes. To understand these approaches, other Syncade tools are also to be discussed in this course such as Service Controller (SC) Consumer, Event Monitor, and Business Integrator.

#### Topics

1. Recipe Fundamentals
2. Simulated Process
3. Parameters
4. SC Consumer
5. Event Monitor
6. Bill of Materials
7. Business Integrator
8. Workflow Types
9. Recipe Objects
10. OPC Communications
11. DeltaV Batch Modules and Recipes
12. Integration Options

#### Prerequisites

7009/7409, 7016 (DeltaV Batch Implementation), 7183 (Equipment Management), 7185 (Manufacturing Management)

#### Audience

MES Engineers, DCS Engineers, Recipe Authors

### IACET Authorized Provider

Educational Services is an Authorized Provider of International Association for Continuing Education and Training (IACET) Continuing Education Units (CEU). IACET Authorized Provider Status Means our Organization:

- Demonstrates compliance with proven, research-based standards created in cooperation with the U.S. Department of Education
- Is dedicated to high standards for quality in continuing education and training
- Awards the IACET CEU, the hallmark for quality in continuing education and training

Educational Services is proud to have received Authorized Provider status and appreciate the opportunity to share our training with you.

### Qualifications for Enrollment

Educational Services agrees to accept for training, individuals who are not competitors of Emerson Process Management in the field to which the training pertains. Educational Services will provide reasonable accommodations to students who have a physical or mental impairment that substantially limits one or more major life activities, as long as the accommodation does not put undue hardship on the Company.

### Course Scheduling, Locations & Pricing

Course schedule and locations including length, dates of each session and price are listed on the Educational Services price sheet that came with your catalog. All prices are in U.S. dollars. For the most up to date information call or visit our website at: [www.emerson.com/education](http://www.emerson.com/education)

### Tuition

Methods of payment include: purchase order, acceptable credit cards include: Visa, MasterCard and American Express. All tuition is subject to change without notice. Transportation, personal expenses and most meals are the responsibility of the student.

### Cancellations & Transfers

If your plans or budgets change, you may cancel/transfer your reservations up to **14 calendar days prior to the start** of the course without incurring a cancellation charge. Limited enrollment makes it necessary to charge **50%** of the full tuition for cancellations/transfers received during the 14 days prior to the start of the course, and full tuition for failure to attend without cancelling. Substitutions are accepted until the first day of class.

### Arrival & Departure Time

Students should plan to arrive the day prior to the course starting day, as class typically begins at 8 a.m. If traveling by air, please allow sufficient time to travel to the airport and check-in when scheduling return transportation.

### Course Materials

All materials presented are copyrighted. Audio and video recording is prohibited and no material or portion of any school may be reproduced in any manner without prior written approval. All necessary documentation, catalogs, and literature are included in the course tuition.

### Continuing Education Units

Continuing Education Units (CEUs) are awarded for the successful completion of most Emerson Process Management schools, based on 80% minimum attendance and satisfactory class and lab participation as determined by the course instructor.

### On-Site and Local Training

Educational Services instructors are available to provide expert training anywhere in the world. We can conduct training tailored to meet your needs at your facility or regional and local sites. To learn more about on-site and local training contact your local Emerson Process Management service provider or call 1-800-338-8158 or 641-754-3771.

### eLearning

Find all eLearning courses in MyCONNECT- Educational Services NEW Self Enrollment Tool  
[www.emerson.com/education](http://www.emerson.com/education) > [MyCONNECT](#)

**Global Training Center Contact Information**

Visit our web page, [www.emerson.com/education](http://www.emerson.com/education), for more details.

For pricing and schedules, please contact the respective site in your area of interest.

**Asia-Pacific, Education Contacts, AP.Education@Emerson.com****Australia**

Emerson Process Management  
471 Mountain Highway  
Bayswater, Victoria Australia 3153  
Phone: + 61 3 9721 0200  
Fax +61 3 9720 6614

**China**

Emerson Process Management Co., Ltd.  
No.1277 Xin Jin Qiao Road Pudong  
New District Shanghai 201206, China  
Phone: 86-21-2892 9640

Emerson Process Management  
Tianjin Service Center  
6B Building, Saida Jimei Industrial Park,  
Xiqing Economic Development Area  
Tianjin 300385 China  
Phone: 86-22-58680700

Emerson Process Management  
Shenzhen Service Center  
Floor 1,8th Building,  
Liangchuang Technology Park,  
No.21 Bulan Rd, Nanwan Street,  
Buji Town, Longgang District  
Shenzhen 518112 China

Emerson Process Management  
Flow Technologies Co., Ltd.  
No.111, Xing Min South Road,  
Jiangning District  
Nanjing 211100 China  
Phone: 86-25-51177888

**India**

Emerson Process Management (I)  
Pvt.Ltd.  
Plot No. EL 109, MIDC  
TTC Industrial Area, Mahape  
Navi Mumbai- 400710 India  
Phone: (91) 22 64543311 / 22

**Japan**

Chiba Solution Center  
2-5-1 Yawata Kitaku, Ichihara-shi  
Chiba-ken 290-0069  
Japan  
Phone: 81 436 44 8311

Mizushima Solution Center  
36-8 36-8,Tsurajima Tsurajima-chou  
Kurashiki-shi  
Okaya-ken 712-8011 Japan  
Phone: 81 86-445-7270

**Malaysia**

Emerson Process Management  
(Malaysia) Sdn Bhd  
No. 1, Block A, Jalan SS 13/5,  
47500 Subang Jaya,  
Selangor Darul Ehsan, Malaysia  
Phone: (603) 5638-1010

**Philippines**

Emerson Process Management  
19F Cyberscape Alpha Building,  
Sapphire & Garnet Rds  
Ortigas Center Pasig City  
Philippines 1605  
Phone: 63 2 7021107

Emerson Electric Asia Ltd.  
16/F SM Cyber West Avenue, EDSA  
Quezon City Philippines 1105  
Phone: 63 2 4793399

**Singapore**

Emerson Process Management  
Asia Pacific PTE LTD  
Educational Services, Singapore  
1 Pandan Crescent  
Singapore 128461  
Phone: (65) 6770 8587  
Fax: (65) 6774 6970

**South Korea**

Emerson Process Management  
Sicox Tower 12 Floor, 513-514  
SeongNam City  
South Korea 462-806  
Phone: 822-2017-1713

**Thailand**

88/4 Mabya Road,  
Map Ta Phut Sub-district Rayong  
Thailand 21150  
Phone: (66) 3869-1353



## Europe, Education Contacts

**Belgium, Diegem**

Emerson Process Management  
De Kleetlaan, 7b  
B-1831  
Diegem  
Belgium  
32-2-716-77-11  
[eu.education@emerson.com](mailto:eu.education@emerson.com)

**United Kingdom, Aberdeen**

Emerson Solutions Centre  
1 Harvest Avenue  
D2 Business Park, Dyce  
Aberdeen, AB21 0BQ  
Phone: +44 1224215700  
[eu.education@emerson.com](mailto:eu.education@emerson.com)

**United Kingdom, Leicester**

Emerson Process Management  
Meridian East  
Meridian Business Park  
Leicester LE19 1UX  
Phone: +440-116-282-2217  
[eu.education@emerson.com](mailto:eu.education@emerson.com)

**France, Bron**

Europarc du Chêne  
14, rue Edison B.P. 21  
F-69671 Bron Cedex France  
Phone: +33 4 721 598 50  
Fax: +33 4 721 534 37  
[eu.education@emerson.com](mailto:eu.education@emerson.com)

**France, Cernay**

Fisher™ Europe Training Center  
Eric Alonso  
Rue Paul Baudry BP10150  
68701 Cernay France  
Phone: +33 3 89 37 65 43  
Fax: +33-389-376-518  
[FisherEurope.education@emerson.com](mailto:FisherEurope.education@emerson.com)

**Russia, Moscow**

Emerson Process Management  
Letnikovskaya st., 10-2, 5 floor  
Moscow, 115114 Russia  
Phone: +7 (095) 981 981 1  
Fax: +7 (095) 981 981 0  
[eu.education@emerson.com](mailto:eu.education@emerson.com)  
[www.emersonprocess.com/russia](http://www.emersonprocess.com/russia)

**Sweden, Gothenburg**

Emerson Automation Solutions  
Rosemount Tank Radar AB  
Layoutvägen 1  
435 33 Mölnlycke  
Sweden  
Phone: +46 31 337 00 00  
[eu.education@emerson.com](mailto:eu.education@emerson.com)

**Denmark**

Emerson Process Management A/S  
Generatorvej 8A, 2.sal  
2860 Søborg, Denmark  
Phone: +4520208629  
Fax: +45 7025 3052  
Contact: Mattias Mollstedt  
[eu.education@emerson.com](mailto:eu.education@emerson.com)

**Finland, Tampere**

Emerson Process Management Oy  
Pakkalankuja 6 01510 VANTAA  
Finland  
Phone: +358 20 1111 200  
Fax: +358 20 1111 260  
[eu.education@emerson.com](mailto:eu.education@emerson.com)

**Germany, Langenfeld**

Emerson Process Management GmbH & Co.  
OHG Trainingszentrum  
Katzbergstr. 1  
D-40764 Langenfeld (Rhld.)  
Germany  
Phone: +49 2173 3348 0  
Fax: +49 2173 3348 100  
[eu.education@emerson.com](mailto:eu.education@emerson.com)

**Germany, Hasselroth**

Emerson Process Management GmbH & Co.  
Trainingszentrum  
Industriestrasse 1  
D-63594 Hasselroth Germany  
Phone: +49 6055 884 472  
Fax: +49 6055 884 469  
[eu.education@emerson.com](mailto:eu.education@emerson.com)

**Italy, Seregno**

Emerson Process Management S.r.l.  
Via Montello, 71/73  
20831 Seregno, MB  
Phone: +39-0362-2285-407  
Fax: +39-0362-243655  
[eu.education@emerson.com](mailto:eu.education@emerson.com)

**Spain, Madrid**

Emerson Process Management S.L  
c/ Francisco Gervas, 1  
28108 Alcobendas (Madrid)  
Spain  
Phone: +34 913586039  
Fax: +34 913589145  
[eu.education@emerson.com](mailto:eu.education@emerson.com)

**Netherlands, Rijswijk**

Patrijsweg 140  
2289 EZ Rijswijk / P.O. Box 212  
2280 AE Rijswijk  
Phone: +31 70 413 6794  
Fax: +31 70 413 6795  
[eu.education@emerson.com](mailto:eu.education@emerson.com)  
[www.emersonprocess.nl](http://www.emersonprocess.nl)

**Netherlands, Ede --**

**Flow BV Training Facility**  
Flow Europe Training Center  
Neonstraat 1  
6718 WX Ede  
The Netherlands  
Phone: +31 (0)318 495 446  
[FlowTraining@Emerson.com](mailto:FlowTraining@Emerson.com)

**Poland, Warsaw**

Emerson Process Management  
Power & Water Solutions Europe Training  
Center  
Szturmowa 2A 02-678  
Warszawa Poland  
Phone : +48-22-45-89-100/101  
Fax: +48-22-45-89-146  
[eu.education@emerson.com](mailto:eu.education@emerson.com)

**United Kingdom, Stirling - Daniel**

Daniel: +44 (0) 1786 433400  
[eu.education@emerson.com](mailto:eu.education@emerson.com)  
Emerson Process Management Limited  
Daniel Measurement & Control  
Logie Court  
Stirling University Innovation Park  
Stirling FK9 4NF

**United Kingdom, Tullibody - Rosemount**

Emerson Process Management  
Dumyat Business Park,  
Block 5, Unit 2, Bond Street  
Tullibody  
FK10 2PB  
Phone : +441259727230  
[eu.education@emerson.com](mailto:eu.education@emerson.com)

**Sweden, Karlstad**

Emerson Process Management AB  
Körkarlsvägen 8  
653 46 Karlstad  
Phone: +46 54 17 27 00  
Fax: +46 54 21 28 04  
[eu.education@emerson.com](mailto:eu.education@emerson.com)

**Latin/South America, Education Contacts****Emerson Process Management Argentina**

Avenida Maipu 660  
1602 Florida  
Provincia de Buenos Aires  
Argentina  
Contact: Cintia Hassan  
Phone: 54-11-4796-7448  
Fax: 54-11-4837-7066  
www.emersonprocess.com.ar

**Mexico, Mexico City**

Emerson Process Management, S.A. de C.V.  
Calle 10 #145  
Col. San Pedro de los Pinos  
Del. Alvaro Obregón, México, D.F. 01180  
Contact: Cinthia Solis  
Phone: +52 55 5809 5367  
Fax: +52 55 5397-4880  
capacitacion.mexico@emerson.com  
www.emersonprocess.com/mx

**Puerto Rico**

Emerson Process Management Puerto Rico  
Los Frailes Industrial Park 475 Street C  
STE 501 Guaynabo  
P.R. 00969  
Contact: Glorimar Vasquez  
Phone: +1 787 782 9955  
Fax: +1 787 782 9574  
e-mail: Training.PuertoRico@Emerson.com

**Brazil, São Paulo**

Emerson Process Management Brazil  
Av. Hollingsworth, 325 - Iporanga  
Sorocaba 18087-105 SP Brazil  
Contact: Camila Elias  
Phone: 55-15-3413-8746  
Fax: 55-15-3413-8000  
treinamento@emerson.com  
www.emersonprocess.com.br

**Middle East/Africa, Education Contacts****Al-Khobar**

Emerson Arabia Inc.  
7th Floor Mazen Al Saeed Business  
Tower Dammam Khobar Highway  
PO Box 3911, Al Khobar 31952  
Kingdom of Saudi Arabia  
Phone: +9663 8147560  
Fax: +96638147570  
mea.education@emerson.com

**Jubail**

Emerson Process Management Arabia, LTD  
PO Box 10305, Jubail 31961  
Kingdom of Saudi Arabia  
Phone: +9663 3408650 ext 400  
Fax: +9663 340 8791  
mea.education@emerson.com

**South Africa, Johannesburg**

Emerson Process Management/  
Alpret Control Specialists  
Cnr. Leader and Hoefyster St.  
Stormill, Roodepoort, 1724,  
Republic of South Africa  
Phone: 27-11-249-6700  
Fax: 27-11-474-8368  
alpret.conspec@alpret.co.za

**Dubai**

Emerson Process Management  
PO Box 17033  
Jebel Ali Freezone - South  
Dubai, U.A.E.  
Phone: +9714 8118100  
Fax: +9714 8865465  
mea.education@emerson.com

**Qatar**

C/O Doha Petroleum Construction Co.  
Alahed Building, Old Salata  
PO Box 1744, Doha Qatar  
Phone: +974 55897481 / +974 44576705  
Fax: +974 44315448  
mea.education@emerson.com

**United Arab Emirates - Abu Dhabi**

**Daniel**  
Phone: +971 2 697 2129 /  
+971 2 697 2018  
mea.education@emerson.com  
Emerson Process Management  
PO Box 105958

**North America, Canada Education Contacts****Edmonton, Calgary, Saskatoon, Fort McMurray, Burnaby**

780-468-5463  
Education-Services@SpartanControls.com  
8403 - 51 Avenue | Edmonton, AB T6E 5L9

Spartan Controls Ltd.  
Fax: 780-440-8361

**EnTech Control**

Division of Emerson Electric Canada Limited  
66 Leek Crescent  
Richmond Hill, Ontario, Canada, L4B 1H1  
Phone: +1 416-709-9716  
Email: Norman.Ito@emerson.com

**Brand/Company, Education Contacts****AMSTM Suite / DeltaVTM/ FOUNDATION™  
fieldbus / Process****Control /PROVOX/ RS3/ SyncadeSmart Operation  
Management / Wireless:**

800-338-8158 or 641-754-3771  
 e-mail: Education@Emerson.com  
 Emerson Process Management, Educational  
 Services  
 PO Box 190/205 South Center Street |  
 Marshalltown, IA 50158-2823  
 Fax: 641-754-3431

**Machinery Health™:**

800-675-4726  
 e-mail: MHM.Training@emerson.com  
 Emerson Process Management  
 835 Innovation Dr. | Knoxville, TN 37932  
 Fax: 865-218-1411

**Ovation™ & WDPF:**

800-445-9723  
 e-mail: Dawn.Smith@Emerson.com  
 Emerson Process Management  
 Power & Water Solutions  
 200 Beta Drive | Pittsburgh, PA 15238  
 Fax: 412-963-3918

**Operational Certainty Consulting:**

203-264-0500  
 e-mail: HP.Slater@emerson.com  
 Emerson Operational Certainty Consulting  
 27 Glen Road, 3rd Floor | Sandy Hook, CT 06482  
 Fax: 203-270-3712

**Rosemount: Gas Analyzers, Gas Chromatographs &  
Liquid Instruments**

800-654-7768  
 email: Training.IVSNarc@Emerson.com  
 Emerson Process Management, Educational  
 Services  
 10241 W. Little York, Suite 200 | Houston, TX 77040

**Actuation Technologies:**

281-477-4513  
 19200 Northwest Freeway  
 Houston, TX 77065  
 Houston, TX courses: 281-477-4513 or 281-477-  
 4590  
 Mansfield, OH courses: 419-529-4311  
 Missouri City, TX courses: 281-499-1561

**Control Valves:**

800-338-8158 or 641-754-3771  
 e-mail: Education@Emerson.com  
 Emerson Process Management, Educational  
 Services  
 PO Box 190/205 South Center Street |  
 Marshalltown, IA 50158-2823  
 Fax: 641-754-3431

**METCO:**

+44 (0)1224 215700  
 e-mail: METCOsales@Emerson.com  
 Jim Reekie, Training Manager  
 Emerson Solutions Centre  
 1 Harvest Avenue | D2 Business Park, Dyce  
 Aberdeen AB21 0BQ

**Plant Safety:**

512-832-3077  
 e-mail: Mark.Dimmitt@Emerson.com  
 Emerson Process Management, Educational  
 Services  
 12301 Research Blvd. - Building III | Austin, TX  
 78759

**Remote Automation Solutions, ROC/FloBoss &  
ControlWave:**

800-395-5497  
 e-mail: RAS\_Training@emerson.com  
 Emerson Process Management, Educational  
 Services  
 1100 Buckingham Street | Watertown, CT 06795  
 Fax: 860-945-2224

**Rosemount Tank Gauging:**

281-988-4000  
 email: Training.RTG.Hou@Emerson.com  
 Emerson Process Management, Educational  
 Services  
 Rosemount Tank Gauging North America, Inc.  
 6005 Rogerdale Road | Houston, Texas 77072 USA

**Daniel:**

713-827-6314  
 e-mail: Tech.Service@Emerson.com  
 Emerson Process Management  
 Daniel Measurement & Control, Inc.  
 11100 Brittmoore Park Drive | Houston, TX 77041  
 Fax: 713-827-6312

**Micro Motion/Rosemount:**

800-338-8158 or 641-754-3771  
 e-mail: Education@Emerson.com  
 Emerson Process Management, Educational  
 Services  
 PO Box 190/205 South Center Street |  
 Marshalltown, IA 50158-2823  
 Fax: 641-754-3431

**Regulators & Relief Valves:**

972-548-3534  
 e-mail: Tammy.Warren@Emerson.com  
 Emerson Process Management Regulator  
 Technologies, Inc.  
 3200 Emerson Way | McKinney, Texas 75070

**Refining Process Training:**

412-826-5440  
 e-mail: Seminars@PetroleumRefining.com  
 Refining Process Services, Inc.  
 1708 Pittsburgh Street, Suite One | Cheswick, PA  
 15024  
 Fax: 412-826-5441

**Roxar Flow Measurement:**

281-879-2600  
 e-mail: Meter.Training@emerson.com  
 Roxar Flow Measurement  
 6005 Rogerdale Road | Houston, Texas 77072 USA



## Educational Services Learning Paths

[Education@emerson.com](mailto:Education@emerson.com)  
Or more training options see us at:  
[www.emerson.com/education](http://www.emerson.com/education)



### DeltaV Operate Implementation I – Introduction – Virtual - 7009V CEUs – 3.2



#### Overview

During the 4-1/2-day course, the student will be able to define system capabilities, define nodes, configure continuous and sequential control strategies, create process alarms, operate the system, troubleshoot the system and modify operator displays.

This course includes access to a virtual DeltaV system to practice and review course workshops complete with brief recorded demonstrations available after course completion.

#### Topics

- System Overview
- DeltaV Explorer
- DeltaV Diagnostics
- Control Modules
- Control Studio
- Motor Control with Interlocking and Permissive Conditions
- Cascade Control
- Regulatory Control
- DeltaV Operate
- System Operation
- Alarms & Process History View
- Alarm Help
- Sequential Function Charts
- Configure Theme Dynamos
- Electronic Marshalling (CHARMS)

#### Audience

This course is designed for process & process control engineers responsible for obtaining key production data, maintaining, configuring and troubleshooting a DeltaV system.

#### Prerequisites

Microsoft Windows experience. Prospective attendees lacking process control experience should first attend Control Loop Foundation, Course 9025. Prospective attendees new to DeltaV should first attend PlantWeb/DeltaV Introduction, or DeltaV Hardware & Troubleshooting, Course 7018.

### DeltaV Systems Batch Implementation - 7016V CEUs – 3.2



#### Overview

This 4-1/2-day course covers the implementation of a complete batch application. A process simulator will provide a batch application. Students will use DeltaV Batch software to configure recipe entities including, Aliasing, Equipment Trains, Dynamic Unit Allocation, Phase Logic, Operations and Unit Procedures. Equipment entities will also be configured including, Units modules and Process cells. This course includes access to a virtual DeltaV system to practice and review course workshops complete with brief recorded demonstrations available after course completion.

#### Topics

- Batch Overview
- Unit Phase
- Alias Definition
- Unit Module
- Process Cell
- Class Based Control Modules
- Class Based Equipment Modules
- Operation
- Unit Procedure
- Procedure
- Equipment Trains
- Unit Aliasing
- Dynamic Unit Allocation

#### Audience

This course is designed for individuals responsible for configuring and commissioning DeltaV Batch software.

#### Prerequisites

Course 7009, DeltaV Implementation I

### DeltaV Implementation II – Intermediate - 7017V CEUs – 3.2



#### Overview

During the 4-1/2-day course, the student will be able to identify function block structures, interpret function block status values, design error masking, define nodes, and configure class-based control modules using the Command-Driven algorithm. This course includes access to a virtual DeltaV system to practice and review course workshops complete with brief recorded demonstrations available after course completion.

#### Topics

- Function Block Structures & Status Values
- Analog Control Palette Blocks PID Bias/Gain, Dead time, Ratio, Signal Characterizer, Splitter
- HART® Inputs and Outputs
- HART Device Alarms
- Unit Alarms
- DeltaV Tune with InSight
- Device Control Options
- Class Based Control Modules
- Configuration of Equipment Modules for Supervisory Control
- Custom Faceplates and Dynamos

#### Audience

This course is for process control engineers responsible for designing, implementing and testing configuration using the DeltaV system.

#### Prerequisites

Course 7009, DeltaV Implementation I



### DeltaV Operate Graphics Interface – Advanced – 7025V CEUs – 3.2



#### Overview

This 4-1/2-day course is for process control engineers responsible for configuring advanced functionality in the DeltaV user interface. This course expands on graphic topics covered in both the DeltaV Implementation course 7009 and DeltaV Implementation II course 7017.

#### Topics

- Visual Basic Primer
- Forms
- Modules
- Schedules
- User Preferences
- Picture Sizing
- Environment Customization
- Custom Faceplates
- Function Block Faceplates
- FRS Functions
- Pop Up Menus
- Color Threshold Tables
- Custom Dynamos
- Tag Groups
- Key Macro Editor
- Theme Dynamos

#### Audience

This course is for process control engineers responsible for configuring advanced functionality in the DeltaV user interface.

#### Prerequisites

Course 7009, DeltaV Implementation I

### DeltaV PMO Configuration Standard - Virtual - 7076V CEUs – 3.2



#### Overview

This 4-1/2 day course will introduce students to the PCSD structure and commonly used PCSD templates for analog, discrete and regulatory control. Students will also learn how to implement new DeltaV control modules using the PCSD library.

Upon completion of this course, the student will be able to:

- Modify existing control strategies while maintaining consistency with the PCSD library
- Add control strategies while maintaining consistency with the PCSD library

#### Topics:

Benefits of a structured approach to configuration

- PCSD Structure
- Operator graphics standards
- Configuration of the following using PCSD class-based modules:
  - Analog value reading and setting
  - Control of discrete devices
  - Loop control
  - Sequential control using Equipment Modules
- Modification of existing PCSD-based control configuration
- PCSD methods for:
  - Module arbitration
  - Mode locking
  - Mode, state and failure propagation
  - Inter-module interfacing
  - Interlocks, permissive and force set points

#### Audience:

This course is designed for engineers and technicians who maintain a DeltaV system configured using the PMO Configuration Standards for DeltaV (PCSD) library.

#### Prerequisites:

Course 7009, DeltaV Implementation I and familiarity with process control

### DeltaV Advanced Control Suite – Virtual – 7201V CEUs – 3.2



#### Overview

This 4-1/2-day course introduces students to the advanced control tools available within the DeltaV system and how they may be used to improve plant operations. The principal technology that is utilized in each product will be discussed. The areas of improvement that may be achieved will be detailed. Also, each student will gain hands on experience with these tools in class exercises based on realistic process simulations.

#### Topics

- The Control Foundation in DeltaV
- Traditional Tools e.g. Override, Cascade, Ratio
- Improvements Provided by Advanced Control
- DeltaV Inspect with InSight
- Detection of Abnormal Conditions
- Performance Indices
- Performance Reports
- DeltaV Tune with InSight
- Measurement of Process Dynamics
- Tuning Methods
- Tuning Response
- Process Learning
- Adaptive Tuning
- Adaptive Control
- DeltaV Fuzzy
- Principles of Fuzzy Logic Control
- FLC Function Block, Tuning
- DeltaV Predict
- MPC for Multi-Variable Control
- Model Identification, Data Screening
- Simulation of Response, Tuning
- DeltaV Neural
- Creation of Virtual Sensor
- Data Screening, Training
- DeltaV Simulate Suite
- Process Simulation
- Simulate Pro

#### Prerequisites

7009, DeltaV Implementation I or equivalent field experience.

### DeltaV Model Predictive Control – 7202V CEUs – 2.4



#### Overview

This 3-1/2-day course is designed for process and control engineers who are applying DeltaV Predict and Predict Pro. It provides practical examples of how to determine the benefits of MPC application and how this control may be used to meet specific application requirements.

Students will gain hands on experience through lab exercises based on realistic dynamic process simulations.

#### Topics

How to Justify an MPC Project

- Evaluating the Cost of Process Variation
- Estimating the Reduction in Variation that is possible using MPC
- Calculating the Benefit of Maximizing throughput when plant production is restricted by Input Limits or Measurable Constraint

Meeting Application Requirements

- Meeting Control Requirements when the Response Times are Very Different
- Understanding the Design and Testing of an Integrating Process

Tailoring Control Performance

- Placing more Emphasis on Selected Control or Constraint Parameters
- Improving Control Performance when the Process is Dead Time Dominant
- Compensating for Large Changes in Process Gain or Dynamics
- Minimizing the Impact of Process Noise on Control Performance

MPC Application

- Selecting and Applying MPC, MPC-Pro and MPC-Plus Blocks

Optimizing Control

- Optimizing the Control Using the MPC-Pro or MPC-Plus Blocks

#### Audience

This course is designed for process and control engineers who are applying DeltaV Predict and Predict Pro.

#### Prerequisites

7201 DeltaV Advanced Control

### DeltaV Batch Analytics Model Builder – Introduction - e7046 CEUs - .80



#### Overview

This 8-hour (average duration) on-line course provides an orientation of Batch Analytics Model Builder. The course includes audio presentations, demonstrations, hands-on practices, hands-on workshops, and quizzes. Course access is 12 months. Upon completion of this course, the student will be able to:

- Define basic principles of Batch Data Analytics and their use in fault detection and quality parameter prediction
- Use the Batch Data Analytics Model Builder application to build and deploy a project for fault detection and quality parameter prediction
- Users will be able to recognize and navigate the screens needed to build a model in Batch Analytics
- Users need to define batch logic, stage logic, and initial condition logic needed for model development
- Users will be able to interpret analytic data of the Model Builder application using a saline example
- Users will be able to build a Batch Data Analytics model

#### Topics

- Batch Analytics Overview
- Batch Analytics Model Builder Overview
- Batch Analytics Viewer Overview
- Batch Saline Simulation
- Benefits of Using Batch Analytics
- Batch Analytics Manager Administration
- Batch Logic, Stage Logic, and Initial Logic Required to Build a Model
- Batch Analytics Model Builder – Equipment
- Batch Analytics Model Builder – Product
- Batch Analytics Model Builder – Model

#### Audience

This course is designed for Chemometricians, Process Engineers, Quality Engineers, and Process Control Engineers.

### DeltaV SIS Implementation – Virtual - 7305V CEUs – 3.2



#### Overview

This 4-1/2-day course is a hands-on instructor led course. The course covers complete DeltaV SIS Implementation including hardware and software architecture. Students will be able to design a DeltaV SIS Network and Safety Instrumented Functions (SIFs). Additionally, students will be able to configure smart SIS instruments and their associated alerts, including partial stroke testing.

#### Topics

- DeltaV SIS Overview
- DeltaV SIS SLS 1508 Hardware Architecture
- DeltaV SIS with Electronic Marshalling Hardware Architecture
- DeltaV Safety Instrumented Functions
- Rosemount SIS Instruments
- AMS Device Manager relating to DeltaV SIS
- Fisher™ SIS Digital Valve Controllers
- SISNet Repeaters
- DeltaV SIS Security
- DeltaV Version Control
- Local Safety Network Bridges

#### Audience

This course is for personnel who design, implement, commission and service DeltaV SIS.

#### Prerequisites

Course 7009 is a requirement. Recommend IEC 61511 knowledge.



#### Emerson Automation Educational Services

[www.emerson.com/education](http://www.emerson.com/education)  
[www.emerson.com/myconnect](http://www.emerson.com/myconnect)

1-800-338-8158

1-641-754-3371

[education@emerson.com](mailto:education@emerson.com)

### DeltaV System Administration - 7027 CEUs – 3.2

#### Overview

This 4-1/2-day course is designed for control system administrators, process control engineers and IT specialist responsible for managing, installing, and commissioning a DeltaV system. This course includes access to a virtual DeltaV system to practice and review course workshops complete with brief recorded demonstrations available after course completion.

#### Topics

- Overview of system components and topologies
- DeltaV domain setup, including independent deltav domain controllers
- DeltaV installation procedures
- Licensing
- Import and export of configuration
- Firmware upgrades
- Controller health diagnostics
- User administration
- Configuration Database administration
- Creating additional workstations
- Auto Update services
- Continuous historian administration
- Advanced continuous historian administration
- Remote desktop services
- Event chronicle administration
- Network Time Protocol configuration/diagnostics
- Backup and restore procedures

#### Audience

This course is designed for control system administrators, process control engineers and IT specialist responsible for managing, installing, and commissioning a DeltaV system.

#### Emerson Automation Educational Services

[www.emerson.com/education](http://www.emerson.com/education)  
[www.emerson.com/myconnect](http://www.emerson.com/myconnect)

1-800-338-8158

1-641-754-3371

[education@emerson.com](mailto:education@emerson.com)

### DeltaV Virtualization – 7029 CEUs 3.2

#### Overview

This 4-1/2-day course focuses on the installation, configuration and system administration of a virtualized DeltaV distributed control system. Using a combination of lectures and workshops students will learn skill sets that enable them to properly plan, implement and maintain a robust DeltaV Virtual Studio (DVS) system intended for online (production) use. A key objective of this course is to prepare students for all aspects of owning a DVS system with special emphasis on providing highly available, reliable and secure access for end users of the DVS system.

#### Topics

- Virtualization Primer — Basics of How Virtualization Works
- Overview of DeltaV Virtualization Solutions
- Planning a DeltaV Virtual Studio System
- Installing and Configuring a VRTX Chassis and Blade Servers
- Creating DeltaV Virtual Machines including a ProfessionalPlus Node
- Configuring a WYSE or a Pepperl+Fuchs Thin Client and Redundant Thin Client Networks
- Create a Highly Available Failover Cluster
- Patching and Hardening of Cluster Nodes
- Cluster Health Monitoring and Troubleshooting
- Disaster Recovery and Replication
- Upgrading and Capacity Expansion

#### Audience

This course is designed for system administrators responsible for installing and maintaining DeltaV Workstations on a virtual platform.

#### Prerequisites

Course 7027, DeltaV Systems Administration for Windows 7 and Server 2008

### AMS Device Manager with DeltaV – 7039 CEUs – 2.8

#### Overview

This 4-day course is for instrumentation technicians responsible for all areas of managing and ensuring the reliability of instrumentation in the plant process including startup and commissioning, normal operations, maintenance, and troubleshooting.

#### Topics

- DeltaV and PlantWeb Overview
- AMS Device Manager Overview
- FOUNDATION™ fieldbus Overview
- ValveLink™ SNAP-ON Introduction
- ValveLink™ DVC Setup
- ValveLink™ SNAP-ON Tests and Diagnostics
- HART® Overview
- PROCONEX QuickCheck SNAP-ON
- PROFIBUS Overview
- PlantWeb Alerts
- AMS Device Manager User Interface
- Setup and use of Alert Monitor in AMS Device Manager
- Device Replacement for HART, Fieldbus, and PROFIBUS Devices
- AMS Device Manager Audit Trail
- AMS Device Manager Calibration Assistant
- Smart Commissioning

#### Audience

The target audience usually does following:

- Responds to work orders created to calibrate, troubleshoot, repair, service, and replace instruments and valves
- Monitors alerts to preemptively address problems prior to operators seeing a problem in the control room
- Provides loop testing & assistance with instrumentation in plant turnarounds, startups, and for project work
- Improves process availability & reduces operations and maintenance costs

#### Prerequisites

Microsoft windows experience. Minimal DeltaV and AMS experience is recommended but not required. Recommended to take 7018, but not required.

### DeltaV Power & Grounding for Electronic Systems– 5590 CEUs – 1.4

#### Overview

This course focuses on specific power and grounding requirements of a control system. You will learn:

- how to conduct site verifications
- how to audit using "hands-on" testing labs
- to detect power and grounding problems on existing sites

#### Topics

- Review of Power Basics
- Power System Measurements
- Low Voltage Power Systems
- Power System Grounding
- Earthing vs. Grounding
- Connection to Earth
- Equipment Grounding
- Code Requirements
- Building Power Distribution
- Feeders and Branch Circuits
- Separately Derived Systems
- Power & Grounding for the DeltaV System
- Single Point Grounding
- Isolated Ground Installations
- Dedicated Circuits
- DC Grounding
- Verifying New Installations
- Power Quality Problems
- Applying Power Conditioning
- SIS Power and Grounding Installation
- Intrinsic Safety Devices

#### Audience

This 2-day course is designed for personnel involved with the planning, installation and maintenance of DeltaV digital automation system and provides essential knowledge regarding the power and grounding system for DeltaV equipment.

#### Prerequisites

A working knowledge of electronics and AC power basics is required.

### DeltaV Hardware & Troubleshooting – 7018 CEUs – 2.8

#### Overview

This course provides an overview of the DeltaV Control Network, M- and S-series hardware, and software applications. Upon completion, you will be familiar with the hard-ware and be able to perform troubleshooting techniques. This 4-day course focuses on the hardware components that make up the DeltaV system: M-series controllers and I/O, S-series controllers and I/O (including CHARMs), and DeltaV Smart Switches. Using a combination of lectures and workshops, you will learn how to use operator and diagnostic tools to identify and locate hard-ware-related fault conditions. Workshops provide the opportunity to disassemble and reassemble the M- and S-series hardware and return the system to an operating state. If your systems include bus technologies such as Foundation Fieldbus, we recommend courses 7030, 7032, or 7037. The 7018 course satisfies the prerequisite requirement for these bus course (except 7032)

#### Topics

- DeltaV Overview
- Operator Alarms
- DeltaV Diagnostics
- DeltaV Smart Switches
- DeltaV I/O Cards and Carriers
- Controllers and Power Supplies
- Electronic Marshalling (CHARMs)
- HART® I/O
- DeltaV and AMS Suite Intelligent Device Manager
- Redundant I/O

#### Audience

This course is recommended for instrumentation and maintenance technicians, managers, and configuration engineers who need to know about DeltaV hardware.

#### Prerequisites

Windows Experience

### DeltaV Fieldbus Devices Maintenance – 7030 CEUs – 2.8

#### Overview

This 4-day lecture/lab course provides maximum hands-on experience working with FOUNDATION™ fieldbus instruments such as: the FIELDVUE™ Digital Valve Controller, Rosemount Pressure and Temperature Transmitters. The student will use the DeltaV control system to commission fieldbus devices, assign foundation fieldbus function blocks to field devices, troubleshoot using diagnostics and AMS Device Manager to manipulate device parameters.

#### Topics

- DeltaV Saleable System Overview
- Macro Cycle Execution
- Fieldbus Function Blocks
- FIELDVUE™ Theory of Operation
- Transmitter Theory of Operation
- AMS Device Manager Methods
- Fieldbus Wiring Practices
- System Troubleshooting
- Accessing Fieldbus Devices
- Alarms and Alerts at DeltaV Workstations
- Segment Checkout Procedures
- Replace Wizard

#### Audience

This course is for individuals responsible for maintaining, troubleshooting, calibrating, and modifying FOUNDATION™ fieldbus device parameters.

#### Prerequisites

Course 7009, DeltaV Implementation I. or 7018, DeltaV Hardware Installation and Troubleshooting

### DeltaV Fieldbus Devices Configuration & Control– 7032 CEUs – 2.8

#### Overview

This 4-day lecture/lab course provides maximum hands-on experience working with FOUNDATION™ fieldbus instruments such as: the FIELDVUE™ Digital Valve Controller, Rosemount Pressure and Temperature Transmitters. The student will use the DeltaV control system to commission fieldbus devices, assign foundation fieldbus function blocks to field devices, troubleshoot using diagnostics and AMS Device Manager to manipulate device parameters.

#### Topics

- FOUNDATION™ fieldbus Overview
- Macro Cycle Execution
- Fieldbus Function Blocks
- Control Anywhere
- Fieldbus Wiring and Installation
- Segment Checkout Procedures
- Commissioning and Configuring Devices
- Control Strategy Configuration
- Configuring an Operator Display

#### Audience

This course is for individuals responsible for designing and configuring FOUNDATION™ fieldbus segments; as well as analyzing the fieldbus macro cycle, troubleshooting fieldbus segments/devices and modifying FOUNDATION™ fieldbus parameters.

#### Prerequisites

7009 DeltaV Implementation I or 7018 DeltaV Hardware Installation and Troubleshooting.

### DeltaV & Communication Bus Interfaces – 7037 CEUs – 2.5

#### Overview

This 3-1/2-day course covers the integration of fieldbus compliant devices using DeltaV systems. Upon completion of the course the student will be able to install, configure and verify proper operations of AS-I, Profibus DP, DeviceNet Serial, EtherNet IP, and Wireless HART® devices, including proper wiring practices. The AMS Intelligent Device Manager will be used to interrogate PROFIBUS DP and Wireless HART devices. The target audience usually does the following:

Responds to work orders created to calibrate, troubleshoot, repair, service, and replace instruments and valves

- Monitors alerts to preemptively address problems prior to operators seeing a problem in the control room
- Provides loop testing and assistance with instrumentation on plant turnarounds, startups, and for project work
- Improves process availability and reduces operations and maintenance costs

#### Topics

- Communication Bus Introduction
- AS-I Overview
- AS-I: Wiring and Installation
- AS-I Network with DeltaV
- PROFIBUS DP Overview
- PROFIBUS Wiring and Installation
- Configuring a PROFIBUS Segment
- Device Net Overview
- Device Net Diagnostics and Configuration
- Troubleshooting
- Serial Interface
- HART® Overview
- Ethernet I/O Overview
- Wireless I/O Overview

#### Audience

The hands-on workshops with DeltaV along with AMS Device Manager will address areas relating to the instrument technician's daily tasks.

#### Prerequisites

7009 DeltaV Implementation I or 7018 DeltaV Hardware Installation and Troubleshooting.

### DeltaV Safety Instrumented System with SLS 1508 Maintenance – 7303 CEUs – 2.1

#### Overview

This 3-day course is a hands-on instructor-led course. The course covers the architecture of the DeltaV SIS including Rosemount SIS instruments and Fisher™ SIS Digital Valve Controllers. Students will gain a working knowledge of the hardware and software allowing them to troubleshoot and maintain the system.

#### Topics

- Safety Lifecycle
- DeltaV SIS Overview
- DeltaV SLS1508 Hardware
- Safety Instrumented Functions
- Rosemount SIS Instruments
- AMS Device Manager
- Fisher™ SIS Digital Valve Controller
- SISNet Repeaters

#### Audience

This course is for Electrical & Instrument technicians, maintenance technicians, E&I/reliability engineers and other personnel responsible for maintaining a DeltaV SIS SLS 1508.

#### Prerequisites

Course 7018, DeltaV Hardware and Troubleshooting, is a requirement.



### DeltaV SIS with Electronic Marshalling Maintenance– 7304 CEUs – 2.1

#### Overview

This 3-day hands-on instructor led course covers the architecture of the DeltaV SIS with Electronic Marshalling including Rosemount SIS instruments and Fisher™ SIS Digital Valve Controllers. Students will be able to identify the DeltaV SIS with Electronic Marshalling hardware and software components. Students will practice troubleshooting and maintenance techniques with DeltaV SIS simulators throughout the course.

#### Topics

- Safety Lifecycle
- DeltaV SIS Overview
- DeltaV SIS with Electronic Marshalling Hardware architecture including power requirements
- Commissioning and Downloading the DeltaV SIS with Electronic Marshalling components
- Safety Instrumented Functions
- Rosemount SIS Instruments
- AMS Device Manager
- Fisher™ SIS Digital Valve Controller
- DeltaV Diagnostics
- DeltaV SIS with AMS Intelligent Device
- Local Safety Network Bridges

#### Audience

This course is for Electrical & Instrument technicians, maintenance technicians, E&I/reliability engineers and other personnel responsible for maintaining DeltaV SIS with Electronic Marshalling.

#### Prerequisites

Course 7018 DeltaV Hardware and Troubleshooting is a requirement.

### DeltaV Batch Operation - Virtual - 7014V CEUs – 1.8



#### Overview

This 2-1/2-day course uses lectures and hands-on workshops to provide an in-depth overview on operating the DeltaV System. It includes all content in course 7012 plus students will:

- understand basic batch terminology
- manipulate Unit Module parameters
- access the Batch Operator Interface
- run procedures
- review batch history data

#### Topics

- System Overview
- Accessing DeltaV Operate Window, Menu Displays and Directories
- Discrete, Analog, Regulatory and Cascade Control Module Operation
- Motor Control Module Operation
- Accessing Alarm Displays/Alarm Handling
- Accessing Real-time/Historical Trend Data
- Accessing Process History View
- Sequential Function Chart Operation
- Phase and Recipe Controls
- Batch Operator Interface
- Batch Historian
- Campaign Manager

#### Audience

This course is for operators, supervisors, and managers responsible for the operation of batch processes using DeltaV system.

### DeltaV Continuous Operation (v11/v12) - e7044 CEUs - .6



#### Overview

This 6-hour (average duration) on-line course provides an orientation of Batch Analytics and how it is used in a production environment. The course includes audio presentations, demonstrations, hands-on practices, hands-on workshops, and quizzes. Upon completion of this course, the student will be able to:

- Define basic principles of Batch Analytics
- Identify how Batch Analytics is used in fault detection and quality parameter prediction
- Identify the Batch List, Quality Prediction, and Fault Detection screens
- Monitor a fault
- Interpret analytic data of a saline example
- Identify the root cause of a detected fault

#### Topics

- Batch Analytics Overview
- Batch Analytics Model Builder Overview
- Batch Analytics Viewer Overview
- Batch Saline Simulation
- Benefits of Using Batch Analytics
- Batch Analytics Viewer – Batch List Tab
- Batch Analytics Viewer – Fault Detection Tab
- Batch Analytics Viewer – Quality Prediction

#### Audience

This course is designed for operators, process engineers, and management.

#### Prerequisites

DeltaV Batch experience and Microsoft Windows experience is required.

### DeltaV Essential Operator Training Solution

#### Overview

DeltaV™ Essential Operator Training Solution is an engineered, hands-on, customized learning environment to up-skill your operations workforce. Operators will learn DeltaV operating concepts using curriculum based on their specific displays as well as hands-on practice workshops relevant to their process.

The DeltaV Essential Operator Training Solution includes instructional materials, customized student curriculum, and workshops all customized to your specific graphics and module types. Student workshops include low fidelity tieback simulation to demonstrate module functionality and perform workshops.

DeltaV Essential Operator Training Solution is available in three delivery formats.

- 1) Traditional classroom with live instructors and equipment
- 2) Virtual classroom environment with live online instruction and DeltaV distributed control systems (DCS)
- 3) A new blended learning environment that uses state-of-the-art technologies to host training in the cloud.

For more information, contact your local Emerson sales office or visit: [www.emerson.com/education](http://www.emerson.com/education)

### Rosemount Fieldbus Measurement Instruments – 2370 CEUs - 2.1

#### Overview

This 3-day class covers the integration of FOUNDATION™ fieldbus compliant measurement devices using the Field Communicator, Emerson USB Fieldbus Modem, AMS Device Manager, and other hosts.

Upon completion of this course students will be able to: install, configure, calibrate, and troubleshoot Rosemount Fieldbus devices which include the 3051C and 3051S Pressure Transmitters, 644, 3144P and 848 Temperature transmitters 5600, 5400 and 5300 Radar Level Transmitters, and 752 Indicator.

#### Topics

- FOUNDATION™ fieldbus Overview
- Fieldbus: Wiring/Segment Design/Function Blocks
- Field Communicator Operation
- AMS Device Manager Operation
- Theory of Operation, Installation, Configuration, Maintenance, Calibration and Troubleshooting on the following:
  - 3051C Pressure Transmitter
  - 3051S Pressure Transmitter
  - 3144P, and 644 Temperature Transmitters
  - 848 Temperature Transmitter
  - 5600, 5400 and 5300 Radar Level Transmitters
  - 752 Fieldbus Indicator

Note: Course may be conducted using other Fieldbus Hosts, such as AMS Device Manager.

#### Audience

This course is for individuals responsible for installing, configuring, calibrating, and troubleshooting FOUNDATION™ fieldbus measurement devices.

#### Prerequisites

Experience in instrument calibration, maintenance, installation, and operation would be helpful.

### DeltaV Fieldbus Devices Maintenance 7030 CEUs – 2.8

#### Overview

This 4-day lecture/lab course provides maximum hands-on experience working with FOUNDATION™ fieldbus instruments such as: the FIELDVUE™ Digital Valve Controller, Rosemount Pressure and Temperature Transmitters. The student will use the DeltaV control system to commission fieldbus devices, assign foundation fieldbus function blocks to field devices, troubleshoot using diagnostics and AMS Device Manager to manipulate device parameters.

#### Topics

- DeltaV Scalable System Overview
- Macro Cycle Execution
- Fieldbus Function Blocks
- FIELDVUE™ Theory of Operation
- Transmitter Theory of Operation
- AMS Device Manager Methods
- Fieldbus Wiring Practices
- System Troubleshooting
- Accessing Fieldbus Devices
- Alarms and Alerts at DeltaV Workstations
- Segment Checkout Procedures
- Replace Wizard

#### Audience

This course is for individuals responsible for maintaining, troubleshooting, calibrating, and modifying FOUNDATION™ fieldbus device parameters.

#### Prerequisites

7009 DeltaV Implementation I or 7018 DeltaV Hardware Installation and Troubleshooting.

### DeltaV Fieldbus Devices Configuration & Control – 7032 CEUs – 2.8

#### Overview

This 4-day lecture/lab course provides maximum hands-on experience working with FOUNDATION™ fieldbus instruments such as: the FIELDVUE™ Digital Valve Controller, Rosemount Pressure and Temperature Transmitters. The student will use the DeltaV control system to commission fieldbus devices, assign foundation fieldbus function blocks to field devices, troubleshoot using diagnostics and AMS Device Manager to manipulate device parameters.

#### Topics

- FOUNDATION™ fieldbus Overview
- Macro Cycle Execution
- Fieldbus Function Blocks
- Control Anywhere
- Fieldbus Wiring and Installation
- Segment Checkout Procedures
- Commissioning and Configuring Devices
- Control Strategy Configuration
- Configuring an Operator Display

#### Audience

This course is for individuals responsible for designing and configuring FOUNDATION™ fieldbus segments; as well as analyzing the fieldbus macro cycle, troubleshooting fieldbus segments/devices and modifying FOUNDATION™ fieldbus parameters.

#### Prerequisites

7009 DeltaV Implementation I or 7018 DeltaV Hardware Installation and Troubleshooting.

### Fisher FOUNDATION Fieldbus FIELDVUE Digital Valve Controller– 7036 CEUs – 2.1

#### Overview

This 3-day course reviews the role and function of control valve positioners followed by a series of hands-on exercises to disassemble, inspect, assemble, install, and commission a FOUNDATION™ fieldbus FIELDVUE™ digital valve controller. During commissioning, students will learn the basics of the FOUNDATION fieldbus protocol, the role of function blocks, addressing, modes and status. Students will configure, calibrate, and commission devices using the 475 Field Communicator and ValveLink™ software. Hands-on exercises also teach students how to perform detailed setup routines and how to run and collect data for various ValveLink software diagnostics.

#### Topics

- Positioner Basics
- FOUNDATION fieldbus overview
- FIELDVUE™ digital valve controller installation and mounting
- Modes and status
- Configuration and calibration with the 475 Field Communicator
- ValveLink™ software guided Setup /Detailed Setup
- Tuning
- Tag management
- Pressure control
- ValveLink software diagnostics
- FIELDVUE instrument troubleshooting

#### Audience

This course teaches technicians and engineers the basics of FOUNDATION™ fieldbus digital valve controller installation, configuration, calibration, and troubleshooting using the 475 Field Communicator, and ValveLink™ software.

#### Prerequisites

Completion of 1450 recommended but not required.



Course Number	Course Name	Plant Engineers	Maintenance Technicians	Plant Operators	Control System Administrators	Plant Management
5590	Power Quality & Grounding for Electronic Systems		A			
7009	DeltaV Implementation I	C	A		C	
7012	DeltaV Operator Interface for Continuous Control			C		A
7014	DeltaV Operator Interface for Batch Control			C		A
7016	DeltaV Systems Batch Implementation	C				
7017	DeltaV Implementation II	A				
7018	DeltaV Hardware & Troubleshooting	A	C		A	
7020	AMS Device Manager	A	C			
7025	DeltaV Advanced Graphics	A				
7026	DeltaV Cybersecurity	A			C	
7027	DeltaV Systems Administration for Windows 7 & Server 2008				C	
7028	DeltaV Virtualization Administration	A			C	
7029	DeltaV Virtualization				A	
7030	Fieldbus Devices		A			
7032	Fieldbus Systems & Devices	A	A			
7037	Communication Interfaces with the DeltaV System	A	A			
7039	AMS Device Manager with DeltaV	A	C			
e7044	Batch Analytics Operator			A		
e7046	Batch Analytics Model Builder	A				
7076	DeltaV PMO Configuration Standard	A				
7201	DeltaV Advanced Control	A				
7201CV	DeltaV Insight	A				
7202	DeltaV Model Predictive Control	A				
7203CV	DeltaV Advanced Control - Custom	A				
7303	DeltaV Safety Instrumented Systems with SLS Maintenance		A			
7304	DeltaV Safety Instrumented Systems with Electronic Marshalling Maintenance		A			
7305	DeltaV SIS Implementation	A				
7409	DeltaV Implementation using DeltaV Live	C	A		C	
7412	DeltaV Live Continuous Operations			C		A
7414	DeltaV Live Batch Operations			C		A
7425	DeltaV Live Graphics Interface – Advanced	A			A	
9025	Control Loop Foundation	P	P			P

Key	
P	Primer
C	Core
A	Advanced / Additional Competencies

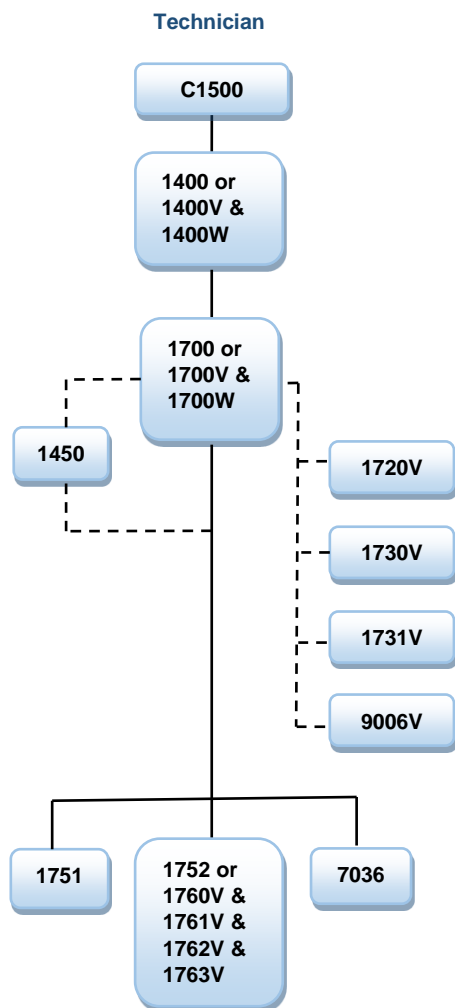
Fisher™  
Learning PathFisher Control Valve - Introduction-  
c1500  
CEUs - .4**Overview**

This curriculum contains e1500, e1501, e1502, and e1503 - the course group introduces the basic terminology of control devices: including control valve types, uses, roles, flow characteristics and to the various entities that define codes and standards for control devices. Sliding stem, rotary, and the basics of an actuator, lists the types of actuators for sliding stem and rotary control valves, states the general components of an actuator and lists general actuator selection guidelines.

Fisher Valve Trim & Body Maintenance-  
1400  
CEUs – 2.1**Overview**

This 3-day course and hands-on workshop explains how valves and actuators function and how they are installed and calibrated. It emphasizes installation, troubleshooting, parts replacement, and calibration of control valves, actuators, and FIELDVUE™ digital valve controllers. Those who complete this course will be able to:

- Correctly perform installation procedures
- Perform basic troubleshooting
- Properly apply and calibrate Fisher FIELDVUE™ digital valve controllers
- Change valve trim, gaskets and packing

**Topics**

- Control valve terminology
- Globe valves
- Packing
- Actuators, and digital valve controllers
- Bench set
- Seat leak testing
- Ball valves
- Butterfly valves
- Eccentric disc valves
- Valve characteristics

**Delivery Options**

This training is also available as a remote virtual classroom course 1400V.

**Audience**

This introductory course is for valve mechanics, maintenance personnel, instrument technicians, and others who are responsible for maintaining control valves, actuators and control valve instrumentation.

**Prerequisites**

Some experience in instrument calibration and in control valve maintenance, installation, and operation would be helpful.

Fisher Valve Trim & Body Maintenance –  
Virtual - 1400V  
CEUs – 1.0**Overview**

This 10-hour remote virtual classroom course consists of 5 virtual classroom parts, 2 hours for each part. It explains how valves and actuators function and how they are installed and calibrated. It emphasizes installation, troubleshooting, parts replacement, and calibration of control valves, actuators, and FIELDVUE™ digital valve controllers. Students also have the option to attend a corresponding hands-on workshop, 1401W, following the completion of the virtual classroom portion of this course. Students who complete this course will be able to:

- Correctly perform installation procedures
- Perform basic troubleshooting
- Properly apply and calibrate Fisher FIELDVUE™ digital valve controllers
- Change valve trim, gaskets and packing

**Topics**

- Control valve terminology
- Globe valves
- Packing
- Actuators, and digital valve controllers
- Bench set
- Seat leak testing
- Ball valves
- Butterfly valves
- Eccentric disc valves

**Delivery Options**

This training is also available as an Instructor Led course 1400.

**Audience**

This introductory course is for valve mechanics, maintenance personnel, instrument technicians, and others who are responsible for maintaining control valves, actuators and control valve instrumentation.

**Prerequisites**

Some experience in instrument calibration and in control valve maintenance, installation, and operation would be helpful.



### Fisher Valve Trim & Body Maintenance - Workshop– 1400W CEUs – .8

#### Overview

This is an 8-hour workshop is offered as an optional component following the 1400V remote virtual classroom event. Students will have the opportunity to perform hands on exercises on control valve bodies and actuators that reinforce the maintenance topics that were discussed during the online portion of the course. The workshop is hosted in Marshalltown, IA and a workshop facilitator will be present to assist the students with any questions they may have while performing the exercises.

#### Workshops

- Fisher easy-e™- valve trim maintenance and repair
- Fisher sliding stem valve packing replacement
- Fisher Sliding stem actuator maintenance and repair
- Fisher 657 and 667 actuator bench set
- Fisher butterfly valve maintenance and repair
- Fisher ball valve maintenance and repair
- Fisher eccentric plug valve maintenance and repair
- Fisher rotary shaft valve packing replacement
- Fisher rotary actuator maintenance and repair
- Fisher rotary valve and actuator mounting

#### Audience

This workshop is intended for any students that have completed the online component of the 1400V course and would like to gain some hands-on experience working with the control valve assemblies.

#### Prerequisites

Must have successfully completed the 1400V course.

### Fisher Control Valve Instrument Maintenance & Calibration– 1700 CEUs – 2.1

#### Overview

This 3-day course and hands-on workshop covers the principles of operation, calibration and installation procedures for electronic and pneumatic instruments. The class will discuss maintenance procedures for Fisher sliding stem and rotary actuator assemblies. Hands on workshop exercises and lectures to discuss the operation and calibration of many Fisher instruments such as I/P transducers, pneumatic positioners, electro-pneumatic positioners, and Fisher FIELDVUE™ digital valve controllers will be covered. Students will:

- Calibrate a variety of pneumatic and electronic instruments
- Correctly perform installation procedures
- Perform basic troubleshooting of control valve instruments

#### Topics

- Actuators and bench set
- Current to pneumatic (I/P) transducers
- Instrument terminology
- Pneumatic and electro-pneumatic positioners
- Fisher FIELDVUE digital valve controller

#### Delivery Options

This training is also available as a remote virtual classroom course 1700V.

#### Audience

This course is for instrument technicians and others, responsible for pneumatic and electronic instrument calibration, installation and troubleshooting.

#### Prerequisites

Some experience in electronic and pneumatic instrument maintenance and calibration would be helpful.

### Fisher Control Valve Instrument Maintenance & Calibration – Virtual – 1700V CEUs – .8



#### Overview

This 8-hour remote virtual classroom course event consists of 4 virtual classroom parts, 2 hours for each part. It will explain the technical operation and maintenance of both sliding stem and rotary actuators. Also discussed will be the design, operation, and calibration principles for both sliding stem and rotary pneumatic positioners. Finally, the course will cover the basic operation and calibration principles for Fisher FIELDVUE digital valve controllers. Fisher documentation will be referenced and used to perform calibration procedures during live interactive sessions. Students also have the option to attend a corresponding hands-on workshop, 1700W, following the completion of the virtual classroom portion of this course.

- Identify and discuss operation principles of Fisher actuators
- Identify and discuss operation principles of Fisher pneumatic positioners
- Identify and discuss operation principles of Fisher I/P transducers
- Identify and discuss operation principles of Fisher FIELDVUE digital valve controllers

#### Topics

- Maintaining Fisher actuators
- Mounting and calibrating Fisher i2P-100
- Mounting and calibrating Fisher 3582 positioners
- Mounting and calibrating Fisher 3610J and 3610JP positioners
- Mounting and calibrating Fisher FIELDVUE digital valve controllers

#### Delivery Options

This training is also available as an Instructor Led course 1700.

#### Audience

This course offers a technical perspective for the working of Fisher positioners for control valve operation. The course is especially useful to anyone with responsibilities to repair, maintain, and calibrate valve positioners.

#### Prerequisites

Some experience with industrial control equipment including control valves and actuators would be helpful.

### Fisher Control Valve Instrument Maintenance & Calibration - Workshop-1700W CEUs – .8

#### Overview

This is an 8-hour workshop that is offered as an optional component following the 1700V virtual classroom event. Students will have the opportunity to perform hands-on exercises on control valve actuators and instrumentation that reinforce the maintenance topics that were discussed during the online portion of the course. The workshop is hosted in Marshalltown, IA and a workshop facilitator will be present to assist the students with any questions they may have while performing the exercises.

#### Workshops

- Fisher sliding stem actuator maintenance and repair
- Fisher 657 and 667 actuator bench set
- Fisher rotary actuator maintenance and repair
- Fisher rotary valve and actuator mounting
- Fisher I/P transducer maintenance and calibration
- Fisher 3582 positioner maintenance and calibration
- Fisher 3610J and 3610JP positioner maintenance and calibration
- Fisher FIELDVUE DVC6200 digital valve controller maintenance and calibration

#### Audience

This workshop is intended for any students that have completed the online component of the 1700V course and would like to gain some hands-on experience working with the control valve assemblies.

#### Prerequisites

Must have successfully completed the 1700V course.

### Fisher Control Valve & Instrument Troubleshooting - Introduction– 1450 CEUs – 2.1

#### Overview

This 3-day course uses a very hands-on approach for troubleshooting and correcting many common control valve problems. The class will be introduced to the practice of basic valve sizing and selection. Valve problems such as cavitation, flashing, and aerodynamic noise are also discussed as well as common solutions to these problems using different control valve trims and materials. Instrumentation topics are expanded from course 1400/1400V and 1700/1700V to include troubleshooting and advanced calibration for split ranging, non-compatible signals, or using additional instruments such as a volume booster and trip valves. Loop performance issues due to stick-slip, high friction, and instrument operation are discussed.

#### Topics

- Control loop basics
- Influences on loop performance
- Control valve selection and sizing
- Valve troubleshooting
- Actuator troubleshooting
- Instrument selection
- Basic instrument troubleshooting
- Severe service considerations

#### Audience

This course is for experienced valve mechanics and maintenance personnel, instrument technicians, and others who will benefit from a broadened perspective of control valve performance and effect on total loop operation.

#### Prerequisites

Completion of courses 1400 or 1400V (with 1400W) and 1700 or 1700V (with 1700W).

### Fisher Pneumatic Pressure Controller Maintenance & Calibration - Virtual – 1720V CEUs – .4



#### Overview

This 4-hour remote virtual classroom course event consists of 2 virtual classroom parts, 2 hours for each part. It will explain the technical operation and maintenance of pneumatic pressure controllers and explain the basics of the proportional, integral, and derivative response. Maintenance of common components such as bourdon tubes and bellows elements will be discussed along with the proper procedures for calibrating various Fisher controllers.

- Fisher C1 pressure controller
- Fisher 4150/4160 pressure controller
- Fisher type 4195 pressure controller

#### Topics

- PID Actions
- Operational overview
- Zero and Span Calibration
- Changing control action
- Bourdon tube replacement C1/4150/4160
- Linkage adjustment 4195
- Flapper Leveling 4195

#### Audience

This course offers a technical perspective of the working of Fisher pneumatic pressure controllers. The course is especially useful to anyone with responsibilities to repair, maintain, calibrate, and tune pressure controllers.

#### Prerequisites

None, however some experience and familiarity to process control and general valve operation is recommended.

**Fisher Pneumatic Level Controller Maintenance & Calibration – 1730V CEUs - .4****Overview**

This 4-hour remote virtual classroom course event consists of 2 virtual classroom parts, 2 hours for each part. It will explain the technical operation and maintenance of pneumatic level controllers and transmitters. A detailed overview of displacer based level methods for applications including single fluid level, interface, and density will be covered. Basics of proportional, integral, and derivative actions are discussed as well as the proper procedures for mounting, calibrating and configuring the devices.

- Fisher 249 Displacer Sensors
- Fisher 2500 level controller
- Fisher 2502 level controller

**Topics**

- Common level measurement methods
- Displacer basics
- Torque tube construction
- Displacer mounting
- Fisher 249 displacer sensor maintenance
- Mounting and calibrating Fisher 2500
- Mounting and calibrating Fisher 2502

**Audience**

This course offers a technical perspective of Fisher pneumatic level controller and transmitter operation. The course is especially useful to anyone with responsibilities to repair, maintain, calibrate, and tune level controllers and transmitters.

**Prerequisites**

None, however some experience and familiarity to process control and general valve operation is recommended.

**Fisher FIELDVUE DLC3010 Digital Level Controller Maintenance and Calibration - Virtual – 1731V CEUs - .4****Overview**

This 4-hour remote virtual classroom course event consists of 2 virtual classroom parts, 2 hours for each part. This course will explain the technical operation and maintenance of FIELDVUE digital level controllers. An overview of displacer based level methods for applications including single fluid level, interface, and density will be covered. The class will also discuss connecting to the device and using AMS™ Device Manager software or a field communicator to perform configuration and calibrations procedures

- Fisher 249 Displacer Sensors
- Fisher FIELDVUE DLC3010

**Topics**

- Displacer basics
- Torque tube construction
- Displacer mounting
- Fisher 249 displacer sensor maintenance
- Mounting Fisher FIELDVUE DLC3010
- Configure FIELDVUE DLC3010 using guided setup for level
- Configure the FIELDVUE DLC3010 for interface applications

**Audience**

This course offers a technical perspective of the Fisher™ FIELDVUE digital level controller DLC3010. The course is especially useful to anyone with responsibilities to repair, maintain, and calibrate FIELDVUE digital level controllers.

**Prerequisites**

None, however some experience and familiarity to process control and general valve operation is recommended. Completion of 1730V is strongly encouraged.

**Fisher Simulated Controller Tuning – Virtual – 9006V CEUs - .8****Overview**

This 8-hour virtual classroom course event consists of 4 parts, 2 hours for each part. Students will be introduced to the fundamentals of PID control. The control and response characteristic of each PID component will be explained and students will have the opportunity to see their effect using simulated loop software accessed through a virtual machine. Using the software, the class will also work through and discuss different strategies for tuning various process loops. These strategies include non-calculation based methods like trial and error, as well as, calculation based methods such as lambda tuning.

**Topics**

- Elements of PID control
- Load upsets; process noise
- Self-regulating process
- Integrating process
- Valve dead band and stick/slip
- Limit cycling
- Trial and error tuning
- Lambda tuning

**Delivery Options**

This training is also available as an Instructor Led course 9006.

**Audience**

This course is designed for those who have the job responsibility of tuning or monitoring industrial process control loops. Students will learn to tune controllers to meet the needs of each loop.

**Prerequisites**

Some basic understanding of process measurement and control is recommended.

### Fisher HART based FIELDVUE Digital Valve Controllers using Emerson Field Communicators & ValveLink Mobile - Introduction- 1751 CEUs – 2.1

#### Overview

This 3-day course provides hands-on experience working with FIELDVUE digital valve controllers using an Emerson 475 or AMS Trex™ Communicator. The class will discuss basic operation and installation of the FIELDVUE digital valve controllers. Students will practice installing and mounting FIELDVUE digital valve controllers onto sliding stem and rotary control valve assemblies, as well as perform basic configuration and calibration of FIELDVUE Instruments. Troubleshooting the digital valve controller using ValveLink™ Mobile software will be performed and basic data interpretation will be introduced.

#### Topics

- FIELDVUE digital valve controller theory of operation
- FIELDVUE instrument installation
- Diagnostic troubleshooting and data interpretation using ValveLink Mobile with AD and PD tier devices

#### Audience

This course is for technicians, engineers and others responsible for installing, calibrating and basic troubleshooting Fisher FIELDVUE instruments using the Emerson Field Communicators with ValveLink Mobile.

#### Prerequisites

Some experience in instrument calibration and in control valve maintenance, installation, and operation would be helpful.

### Fisher ValveLink Solo Software for Configuration & Calibration of FIELDVUE Digital Valve Controllers- 1752 CEUs – 2.1

#### Overview

This 3-day course provides hands-on experience working with FIELDVUE digital valve controllers and ValveLink software. Students will be able to execute ValveLink software calibration and diagnostic routines and create an instrument database.

#### Topics

- Introduction to ValveLink Solo software
- Configuration with ValveLink software
- Calibration with ValveLink software
- ValveLink software advanced and performance Tier Diagnostics
- Troubleshooting
- Introduction to diagnostic data interpretation

#### Delivery Options

This training is also available as a remote virtual classroom course training by attending courses 1760V, 1761V, 1762V, and 1763V

#### Audience

This course is for technicians, engineers and others responsible for installation, calibration and diagnostics for FIELDVUE digital valve controllers and ValveLink software. The primary focus of this course is to provide a comprehensive experience in managing digital valve controllers using the ValveLink software.

#### Prerequisites

Some experience in instrument calibration and in control valve maintenance, installation, and operation would be helpful.

### Fisher FIELDVUE Digital Valve Controllers – Virtual – 1760V CEUs - .4



#### Overview

This 4-hour remote virtual classroom course event consists of 2 virtual classroom parts, 2 hours for each part. It covers detailed operation of Fisher FIELDVUE digital valve controllers. Class discussions are centered on what individual components within a digital valve controller are, and how they can affect overall control valve performance. Common maintenance practices are detailed, and include proper care and handling of internal components, such as the I/P and Relay. Calibration procedures of the FIELDVUE DVC6200 digital valve controller will be conveyed using ValveLink™ software connected to a live device. Course focus includes:

- Identify and understand components of a digital valve controller
- Describe and demonstrate proper instrument mounting
- Connect to a live device using ValveLink Software
- Discuss and perform a guided setup routine
- Discuss and perform an auto travel calibration routine

#### Topics

- Pneumatic instrument principle overview
- Operation of a FIELDVUE digital valve controller for travel control
- Operation of a FIELDVUE digital valve controller for pressure control
- Replacing FIELDVUE digital valve controller components
- Mounting a FIELDVUE digital valve controller
- Calibrating a FIELDVUE digital valve controller

#### Audience

This course is designed for those who have the job responsibility to repair, mount, configure, and calibrate Fisher FIELDVUE digital valve controllers.

#### Prerequisites

Experience and familiarity of process control and general valve operation is recommended. Completion of course 1700 or 1700V is strongly encouraged.

**Fisher FIELDVUE Digital Valve Controller HART Communicating Tier - Virtual- 1761V**  
CEUs - .4



**Overview**

This 4-hour remote virtual classroom course event consists of 2 virtual classroom parts, 2 hours for each part. It covers the detailed setup of the FIELDVUE digital valve controllers. The class will discuss navigating through the detailed setup menus to change device operation and configuration parameters, as well as set alerts and alarms and correctly complete the device specification sheet. Students will have access to a live FIELDVUE DVC6200 using ValveLink™ software. In conjunction with HC tiering capabilities, a basic understanding of functions and troubleshooting within ValveLink software is discussed at length. Course focus includes:

- Detailed Setup - basic page group
- Detailed Setup - alert page group
- Detailed Setup - specification sheet
- Status Monitor
- Stroke Valve Test

**Topics**

- Saving device configuration as found
- Viewing device datasets
- Comparing current datasets to historical datasets
- Restoring historical datasets
- Using status monitor
- Interpreting data from status monitor
- Performing a stroke valve test

**Audience**

This course is designed for those who have the job responsibility to perform detailed configurations and basic diagnostic troubleshooting of FIELDVUE digital valve controllers with HC tier.

**Prerequisites**

Successful completion of 1760V is required.

**Fisher FIELDVUE Digital Valve Controller Advanced Diagnostics Tier – Virtual – 1762V**  
CEUs - .4



**Overview**

This 4-hour remote virtual classroom course event consists of 2 virtual classroom part, 2 hours for each part. It introduces data collection methods for offline diagnostic testing and troubleshooting of the FIELDVUE digital valve controllers with Advanced Diagnostic (AD) Tier. Students will have access to a live FIELDVUE DVC6200 using ValveLink™ software, and will discuss the proper setup and execution of diagnostic functionality within the AD tier. Dynamic scan and step response tests will be conducted, and the class will interpret analyzed data and review the details of diagnostic graphs for each. Areas of focus for AD diagnostic functionality include:

- Step Response Test - stroking speed
- Step Response Test - 9 -point step test
- Step Response Test - performance test
- Step Response Test – 3-point ramp
- Step Response Test - supply pressure
- Step Response Test - drive signal
- Valve Signature - graph and analyzed data
- Dynamic Error Band
- Drive Signal

**Topics**

- Verifying specification sheet information
- Viewing/initializing AD related diagnostic information
- Identifying common features of diagnostic graphs
- Interpreting AD tier diagnostics

**Audience**

This course is designed for those with job responsibilities to configure and perform diagnostic tests as well as interpret diagnostic data of the FIELDVUE digital valve controller with AD tiering.

**Prerequisites**

Successful completion of 1760V and 1761V is required.

**Fisher FIELDVUE Digital Valve Controller Performance Diagnostics Tier - Virtual- 1763V**  
CEUs - .4



**Overview**

This 4-hour remote virtual classroom course event consists of 2 virtual classroom parts, 2 hours each part. It introduces data collection methods for online diagnostic testing and troubleshooting of the FIELDVUE digital valve controllers with Performance Diagnostic (PD) Tier. Students will have access to a live FIELDVUE DVC6200 device using ValveLink™ software, and will discuss the proper setup and execution of diagnostic functionality within the PD tier. Permanent tiering step-up options are discussed, including the free one-time step up to PD tier, as well as specific procedures to follow when changing a digital valve controller's diagnostic tier. Diagnostic functions of interest include:

- PD One Button
- Profiles
- Triggered Profiles
- Friction
- Friction Trends

**Topics**

- Verifying specification sheet information
- Running a PD One Button Test
- Viewing/analyzing PD related diagnostic information
- Configuring scheduler to run diagnostics
- Configuring/Activating trending and network alert scan functions
- Understanding digital valve controller diagnostic tiering levels

**Audience**

This course is designed for those with job responsibilities to perform and interpret online diagnostic tests associated with the FIELDVUE digital valve controller with PD tiering.

**Prerequisites**

Successful completion of 176V, 1761V, and 1762V is required.



**Fisher FOUNDATION Fieldbus  
FIELDVUE Digital Valve Controller –  
7036  
CEUs – 2.1**

**Overview**

This 3-day course reviews the role and function of control valve positioners followed by a series of hands-on exercises to disassemble, inspect, assemble, install, and commission a FOUNDATION fieldbus FIELDVUE digital valve controller. During commissioning, students will learn the basics of the FOUNDATION fieldbus protocol, the role of function blocks, addressing, modes and status. Students will configure, calibrate, and commission devices using Emerson Communicator and ValveLink™ Solo software. Hands-on exercises also teach students how to perform detailed setup routines and how to run and collect data for various ValveLink software diagnostics.

**Topics**

- Positioner Basics
- FOUNDATION fieldbus overview
- FIELDVUE digital valve controller installation and mounting
- Modes and status
- Configuration and calibration with the 475 or AMS Trex™ Communicator and ValveLink Mobile
- ValveLink™ software guided Setup /Detailed Setup
- Tuning
- Tag management
- Pressure control
- ValveLink software diagnostics
- FIELDVUE instrument troubleshooting

**Audience**

This course teaches technicians and engineers the basics of FOUNDATION fieldbus digital valve controller installation, configuration, calibration, and troubleshooting.

**Prerequisites**

Some experience in instrument calibration and in control valve maintenance, installation, and operation would be helpful.

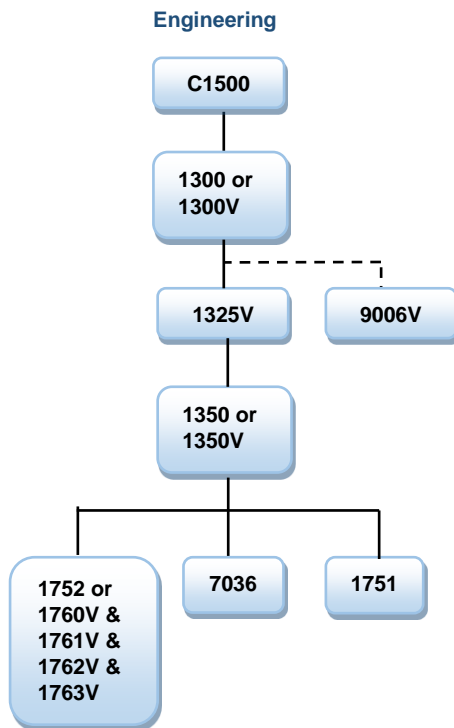
Fisher™ Valve  
Learning PathFisher Control Valve - Introduction-  
c1500  
CEUs - .4**Overview**

This curriculum contains e1500, e1501, e1502, and e1503 - the course group introduces the basic terminology of control devices: including control valve types, uses, roles, flow characteristics and to the various entities that define codes and standards for control devices. Sliding stem, rotary, and the basics of an actuator, lists the types of actuators for sliding stem and rotary control valves, states the general components of an actuator and lists general actuator selection guidelines.

Fisher Control Valve Engineering -  
Introduction – 1300  
CEUs – 2.1**Overview**

This 3-day course reviews design and operating principles of control valves, actuators, positioners and related accessories. It describes the sizing and selection methods for a broad variety of control valves assemblies. Students will solve several demonstration sizing and selection problems using Fisher Specification Manager software and published materials, plus participate in equipment demonstrations and hands-on workshops. Students who complete this course will:

- Select the proper valve characteristic for a given process
- Choose suitable styles of control valves for an application
- Size control valves and actuators
- Properly apply positioners and instruments

**Topics**

- Control valve selection: rotary/sliding stem
- Actuator selection and sizing
- Liquid valve sizing
- Gas valve sizing
- Positioners and transducers
- Valve guidelines
- Valve characteristics
- Valve packing considerations

**Delivery Options**

This training is also available as a remote virtual classroom course 1300V.

**Audience**

This course is for engineers, technicians and others responsible for the selection, sizing, and application of control valves, actuators and control valve instrumentation.

**Prerequisites**

Some experience with industrial control equipment including control valves and actuators would be helpful.

Fisher Control Valve Engineering –  
Introduction – Virtual - 1300V  
CEUs – 1.6**Overview**

This 16-hour remote virtual classroom course event consists of 8 virtual classroom parts, 2 hours for each part. It reviews design and operating principles of control valves, actuators, positioners and related accessories. It describes the sizing and selection methods for a broad variety of control valves assemblies. Students will solve several demonstration sizing and selection problems using Fisher Specification Manager software and published materials. Students who complete this course will:

- Select the proper valve characteristic for a given process
- Choose suitable styles of control valves for an application
- Size control valves and actuators
- Properly apply positioners and instruments

**Topics**

- Control valve selection: rotary/sliding stem
- Actuator selection and sizing
- Liquid valve sizing
- Gas valve sizing
- Positioners and transducers
- Valve guidelines
- Valve characteristics
- Valve packing considerations

**Delivery Options:**

This training is also available as an Instructor Led course 1300.

**Audience**

This course is specifically tailored to technicians, engineers and others responsible for the proper selection, sizing, and application of control valve assemblies.

**Prerequisites**

Some experience with industrial control equipment including control valves and actuators would be helpful.

### Fisher Simulated Controller Tuning - Virtual – 9006V CEUs - .8



#### Overview

This 8-hour virtual classroom course event consists of 4 parts, 2 hours for each part. Students will be introduced to the fundamentals of PID control. The control and response characteristic of each PID component will be explained and students will have the opportunity to see their effect using simulated loop software accessed through a virtual machine. Using the software, the class will also work through and discuss different strategies for tuning various process loops. These strategies include non-calculation based methods like trial and error, as well as, calculation based methods such as lambda tuning.

#### Topics

- Elements of PID control
- Load upsets; process noise
- Self-regulating process
- Integrating process
- Valve dead band and stick/slip
- Limit cycling
- Trial and error tuning
- Lambda tuning

#### Delivery Options

This training is also available as an Instructor Led course 9006.

#### Audience

This course is designed for those who have the job responsibility of tuning or monitoring industrial process control loops. Students will learn to tune controllers to meet the needs of each loop.

#### Prerequisites

Some basic understanding of process measurement and control is recommended.

### Fisher Control Valve Engineering – Intermediate - 1325V CEUs - .8



#### Overview

This 8-hour remote virtual classroom course event consists of 4 virtual classroom part, 2 hours for each part. It reviews design and operating principles of control valves in various applications. It describes the sizing and selection methods utilized in selecting appropriate control valve assemblies, as they relate to severe service applications such as noise and cavitation. Students will solve several advanced sizing and selection problems using Fisher Specification Manager software and published materials. Students will also have the opportunity to ask Emerson certified instructors for Fisher

### Fisher Control Valve Engineering – Intermediate - 1325V – Continued...

engineering courses to clarify questions and assist in better understanding of these advanced fluid mechanic ideas. Students who successfully complete this course will:

- Size control valves and trim for a cavitating application
- Size control valves and trim for a noisy application
- Choose suitable styles of control valves for an application
- Size control valves for an erosive and/or corrosive application
- Properly apply knowledge learned from 1300 or 1300V

#### Topics

- Cavitation and flashing
- Noise
- Corrosion
- Erosion
- Valve application guidelines

#### Audience

This course is designed for engineers, technicians and others responsible for the selection, sizing, and application of control valve assemblies.

#### Prerequisites

Successful completion of 1300V or 1300 is required. Familiarity with sizing, selection, and advanced applications of control valves is strongly encouraged.

### Fisher Control Valve Engineering – Advanced – 1350 CEUs – 2.1

#### Overview

This 3-day course reviews advanced application-specific design and operating principles of control valve assemblies, instruments, and accessories installed in a variety of non-general service applications. Students will gain insight in sizing and selection methods utilized in selecting appropriate control valve assemblies, as they relate to advanced control topics. Fisher Specification Manager software, combined with published reference materials, will be used to solve several advanced sizing and selection problems. Students will also have the opportunity to ask Emerson certified Fisher engineering instructors clarifying questions to firmly understand the advanced fluid mechanics covered in this course. Students who successfully complete the course will:

- Properly apply knowledge learned from 1300/1300V and 1325V
- Review basic sizing of control valves and build on the complexity of applications

### Fisher Control Valve Engineering – Advanced – 1350 – Continued...

- Review basics of thermodynamics and how those concepts relate to the sizing model
- Discuss key ideas involving cryogenic control valve assembly applications
- Size and select control valves for two-phase flow of hydrocarbon mixtures and dissolved gas
- Size and select actuators and pneumatic accessories for stroking speed requirements
- Gain insight into instrument diagnostics and optimum loop performance
- Learn the basics of steam conditioning processes and associated equipment

#### Topics

- Cavitation and flashing
- Noise
- Basic thermodynamics
- Cryogenic valves
- Two-phase flow
- Stroking speed
- Steam conditioning
- Control valve optimum loop performance
- Control Valve Diagnostic Basics

#### Delivery Options

This training is also available as a remote virtual classroom course 1350V.

#### Audience

This course is specifically tailored to technicians, engineers and others responsible for the proper selection, sizing, and application of control valve assemblies.

#### Prerequisites

Successful completion of 1300 or 1300V and 1325V is required. Familiarity with sizing, selection, and advanced application of control valves is strongly encouraged.

### Fisher Control Valve Engineering – Advanced – Virtual - 1350V CEUs – 1.6



#### Overview

This 16-hour remote virtual classroom course event consists of 8 virtual classroom, 2 hour for each part. It reviews advanced application-specific design and operating principles of control valve assemblies, instruments, and accessories installed in a variety of non-general service applications.

Students will gain insight in sizing and selection methods utilized in selecting appropriate control valve assemblies, as they relate to advanced control topics. Fisher Specification Manager software, combined with published reference materials, will be used to solve several advanced sizing and selection problems. Students will also have the opportunity to ask Emerson certified Fisher engineering instructors clarifying questions to firmly understand the advanced fluid mechanics covered in this course. Students who successfully complete the course will:

- Properly apply knowledge learned from 1300 or 1300V and 1325
- Review basic sizing of control valves and build on the complexity of applications
- Review basics of thermodynamics and how those concepts relate to the sizing model
- Discuss key ideas involving cryogenic control valve assembly applications
- Size and select control valves for two-phase flow of hydrocarbon mixtures and dissolved gas
- Size and select actuators and pneumatic accessories for stroking speed requirements
- Gain insight into instrument diagnostics and optimum loop performance
- Learn the basics of steam conditioning processes and associated equipment

#### Topics

- Cavitation and flashing
- Noise
- Basic thermodynamics
- Cryogenic valves
- Two-phase flow
- Stroking speed
- Steam conditioning
- Control valve optimum loop performance
- Control Valve Diagnostic Basics

#### Delivery Options

This training is also available as an Instructor Led course 1350.

### Fisher Control Valve Engineering – Advanced – Virtual - 1350V – Continued...

#### Audience

It is specifically tailored to technicians, engineers and others responsible for the proper selection, sizing, and application of control valve assemblies.

#### Prerequisites

Successful completion of 1300 or 1300V and 1325V is required. Familiarity with sizing, selection, and advanced application of control valves is strongly encouraged.

### Fisher ValveLink Solo Software for Configuration & Calibration of FIELDVUE Digital Valve Controllers – 1752 CEUs – 2.1

#### Overview

This 3-day course provides hands-on experience working with FIELDVUE digital valve controllers and ValveLink software. Students will be able to execute ValveLink software calibration and diagnostic routines, and create an instrument database.

#### Topics

- Introduction to ValveLink Solo software
- Configuration with ValveLink software
- Calibration with ValveLink software
- ValveLink software advanced and performance Tier Diagnostics
- Troubleshooting
- Introduction to diagnostic data interpretation

#### Delivery Options

This training is also available as a remote virtual classroom course training by attending courses 1760V, 1761V, 1762V, and 1763V

#### Audience

This course is for technicians, engineers and others responsible for installation, calibration and diagnostics for FIELDVUE digital valve controllers and ValveLink software. The primary focus of this course is to provide a comprehensive experience in managing digital valve controllers using the ValveLink software.

#### Prerequisites

Some experience in instrument calibration and in control valve maintenance, installation, and operation would be helpful.

### Fisher FIELDVUE Digital Valve Controllers - Virtual – 1760V CEUs - .4



#### Overview

This 4-hour remote virtual classroom course event consists of 2 virtual classroom parts, 2 hours for each part. It covers detailed operation of Fisher FIELDVUE digital valve controllers. Class discussions are centered on what individual components within a digital valve controller are, and how they can affect overall control valve performance. Common maintenance practices are detailed, and include proper care and handling of internal components, such as the I/P and Relay. Calibration procedures of the FIELDVUE DVC6200 digital valve controller will be conveyed using ValveLink™ software connected to a live device. Course focus includes:

- Identify and understand components of a digital valve controller
- Describe and demonstrate proper instrument mounting
- Connect to a live device using ValveLink Software
- Discuss and perform a guided setup routine
- Discuss and perform an auto travel calibration routine

#### Topics

- Pneumatic instrument principle overview
- Operation of a FIELDVUE digital valve controller for travel control
- Operation of a FIELDVUE digital valve controller for pressure control
- Replacing FIELDVUE digital valve controller components
- Mounting a FIELDVUE digital valve controller
- Calibrating a FIELDVUE digital valve controller

#### Audience

This course is designed for those who have the job responsibility to repair, mount, configure, and calibrate Fisher FIELDVUE digital valve controllers.

#### Prerequisites

Experience and familiarity of process control and general valve operation is recommended. Completion of course 1700 or 1700V is strongly encouraged.

**Fisher FIELDVUE Digital Valve Controller HART Communicating Tier - Virtual – 1761V**  
CEUs - .4



**Overview**

This 4-hour remote virtual classroom course event consists of 2 virtual classroom parts, 2 hours for each part. It covers the detailed setup of the FIELDVUE digital valve controllers. The class will discuss navigating through the detailed setup menus to change device operation and configuration parameters, as well as set alerts and alarms and correctly complete the device specification sheet. Students will have access to a live FIELDVUE DVC6200 using ValveLink™ software. In conjunction with HC tiering capabilities, a basic understanding of functions and troubleshooting within ValveLink software is discussed at length. Course focus includes:

- Detailed Setup - basic page group
- Detailed Setup - alert page group
- Detailed Setup - specification sheet
- Status Monitor
- Stroke Valve Test

**Topics**

- Saving device configuration as found
- Viewing device datasets
- Comparing current datasets to historical datasets
- Restoring historical datasets
- Using status monitor
- Interpreting data from status monitor
- Performing a stroke valve test

**Audience**

This course is designed for those who have the job responsibility to perform detailed configurations and basic diagnostic troubleshooting of FIELDVUE digital valve controllers with HC tier.

**Prerequisites**

Successful completion of 1760V is required.

**Fisher FIELDVUE Digital Valve Controller Advanced Diagnostics Tier - Virtual – 1762V**  
CEUs - .4



**Overview**

This 4-hour remote virtual classroom course event consists of 2 virtual classroom parts, 2 hours for each part. It introduces data collection methods for offline diagnostic testing and troubleshooting of the FIELDVUE digital valve controllers with Advanced Diagnostic (AD) Tier. Students will have access to a live FIELDVUE DVC6200 using ValveLink™ software, and will discuss the proper setup and execution of diagnostic functionality within the AD tier. Dynamic scan and step response tests will be conducted, and the class will interpret analyzed data and review the details of diagnostic graphs for each. Areas of focus for AD diagnostic functionality include:

- Step Response Test - stroking speed
- Step Response Test - 9 -point step test
- Step Response Test - performance test
- Step Response Test – 3-point ramp
- Step Response Test - supply pressure
- Step Response Test - drive signal
- Valve Signature - graph and analyzed data
- Dynamic Error Band
- Drive Signal

**Topics**

- Verifying specification sheet information
- Viewing/initializing AD related diagnostic information
- Identifying common features of diagnostic graphs
- Interpreting AD tier diagnostics

**Audience**

This course is designed for those with job responsibilities to configure and perform diagnostic tests as well as interpret diagnostic data of the FIELDVUE digital valve controller with AD tiering.

**Prerequisites**

Successful completion of 1760V and 1761V is required.

**Fisher FIELDVUE Digital Valve Controller Performance Diagnostics Tier - Virtual– 1763V**  
CEUs - .4



**Overview**

This 4-hour remote virtual classroom course event consists of 2 virtual classroom parts, 2 hours each part. It introduces data collection methods for online diagnostic testing and troubleshooting of the FIELDVUE digital valve controllers with Performance Diagnostic (PD) Tier. Students will have access to a live FIELDVUE DVC6200 device using ValveLink™ software, and will discuss the proper setup and execution of diagnostic functionality within the PD tier. Permanent tiering step-up options are discussed, including the free one-time step up to PD tier, as well as specific procedures to follow when changing a digital valve controller's diagnostic tier. Diagnostic functions of interest include:

- PD One Button
- Profiles
- Triggered Profiles
- Friction
- Friction Trends

**Topics**

- Verifying specification sheet information
- Running a PD One Button Test
- Viewing/analyzing PD related diagnostic information
- Configuring scheduler to run diagnostics
- Configuring/Activating trending and network alert scan functions
- Understanding digital valve controller diagnostic tiering levels

**Audience**

This course is designed for those with job responsibilities to perform and interpret online diagnostic tests associated with the FIELDVUE digital valve controller with PD tiering.

**Prerequisites**

Successful completion of 176V, 1761V, and 1762V is required.



**Fisher FOUNDATION Fieldbus  
FIELDVUE Digital Valve Controller –  
7036  
CEUs – 2.1**

**Overview**

This 3-day course reviews the role and function of control valve positioners followed by a series of hands-on exercises to disassemble, inspect, assemble, install, and commission a FOUNDATION fieldbus FIELDVUE digital valve controller. During commissioning, students will learn the basics of the FOUNDATION fieldbus protocol, the role of function blocks, addressing, modes and status. Students will configure, calibrate, and commission devices using Emerson Communicator and ValveLink™ Solo software. Hands-on exercises also teach students how to perform detailed setup routines and how to run and collect data for various ValveLink software diagnostics.

**Topics**

- Positioner Basics
- FOUNDATION fieldbus overview
- FIELDVUE digital valve controller installation and mounting
- Modes and status
- Configuration and calibration with the 475 or AMS Trex™ Communicator and ValveLink Mobile
- ValveLink™ software guided Setup /Detailed Setup
- Tuning
- Tag management
- Pressure control
- ValveLink software diagnostics
- FIELDVUE instrument troubleshooting

**Audience**

This course teaches technicians and engineers the basics of FOUNDATION fieldbus digital valve controller installation, configuration, calibration, and troubleshooting.

**Prerequisites**

Some experience in instrument calibration and in control valve maintenance, installation, and operation would be helpful.

**Fisher HART based FIELDVUE Digital  
Valve Controllers using Emerson Field  
Communicators & ValveLink Mobile -  
Introduction– 1751  
CEUs – 2.1**

**Overview**

This 3-day course provides hands-on experience working with FIELDVUE digital valve controllers using an Emerson 475 or AMS Trex™ Communicator. The class will discuss basic operation and installation of the FIELDVUE digital valve controllers. Students will practice installing and mounting FIELDVUE digital valve controllers onto sliding stem and rotary control valve assemblies, as well as perform basic configuration and calibration of FIELDVUE Instruments. Troubleshooting the digital valve controller using ValveLink™ Mobile software will be performed and basic data interpretation will be introduced.

**Topics**

- FIELDVUE digital valve controller theory of operation
- FIELDVUE instrument installation
- Diagnostic troubleshooting and data interpretation using ValveLink Mobile with AD and PD tier devices

**Audience**

This course is for technicians, engineers and others responsible for installing, calibrating and basic troubleshooting Fisher FIELDVUE instruments using the Emerson Field Communicators with ValveLink Mobile.

**Prerequisites**

Some experience in instrument calibration and in control valve maintenance, installation, and operation would be helpful.

Fisher™ Valve  
Learning Path

## Valve Diagnostics

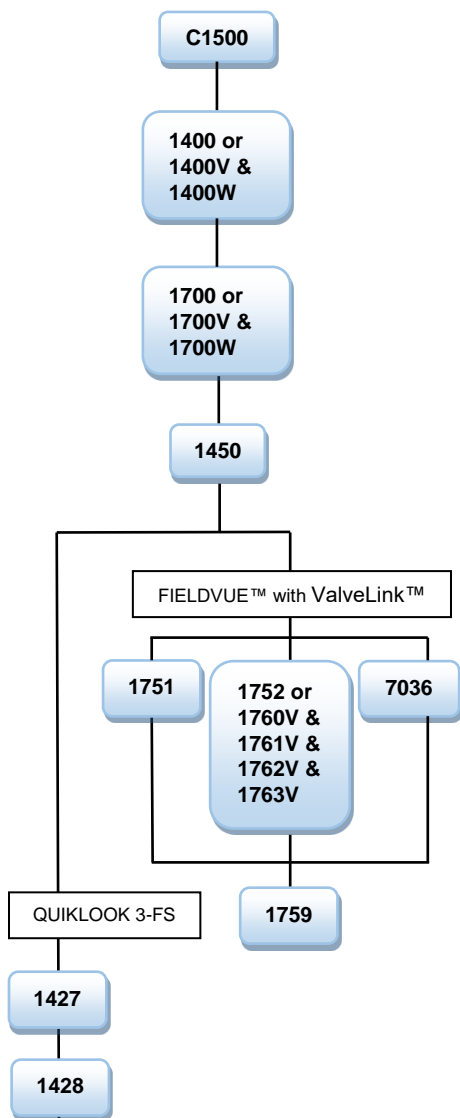
Fisher Control Valve - Introduction-  
c1500  
CEUs - .4

## Overview

This curriculum contains e1500, e1501, e1502, and e1503 - the course group introduces the basic terminology of control devices: including control valve types, uses, roles, flow characteristics and to the various entities that define codes and standards for control devices. Sliding stem, rotary, and the basics of an actuator, lists the types of actuators for sliding stem and rotary control valves, states the general components of an actuator and lists general actuator selection guidelines.

Fisher Valve Trim & Body Maintenance-  
1400  
CEUs – 2.1

## Overview

This 3-day course and hands-on workshop explains how valves and actuators function and how they are installed and calibrated. It emphasizes installation, troubleshooting, parts replacement, and calibration of control valves, actuators, and FIELDVUE™ digital valve controllers. Those who complete this course will be able to:

- Correctly perform installation procedures
- Perform basic troubleshooting
- Properly apply and calibrate Fisher FIELDVUE™ DVC6200 digital valve controllers
- Change valve trim, gaskets and packing

## Topics

- Control valve terminology
- Globe valves
- Packing
- Actuators, and digital valve controllers
- Bench set
- Seat leak testing
- Ball valves
- Butterfly valves
- Eccentric disc valves
- Valve characteristics

## Delivery Options

This training is also available as a remote virtual classroom course 1400V.

## Audience

This introductory course is for valve mechanics, maintenance personnel, instrument technicians, and others who are responsible for maintaining control valves, actuators and control valve instrumentation.

## Prerequisites

Some experience in instrument calibration and in control valve maintenance, installation, and operation would be helpful.

Fisher Valve Trim & Body Maintenance –  
Virtual – 1400V  
CEUs – 1.0

## Overview

This 10-hour remote virtual classroom course event consists of 5 virtual classroom parts, 2 hours for each part. It explains how valves and actuators function and how they are installed and calibrated. It emphasizes installation, troubleshooting, parts replacement, and calibration of control valves, actuators, and FIELDVUE™ digital valve controllers. Students also have the option to attend a corresponding hands-on workshop, 1401W, following the completion of the virtual classroom portion of this course. Students who complete this course will be able to:

- Correctly perform installation procedures
- Perform basic troubleshooting
- Properly apply and calibrate Fisher FIELDVUE™ DVC6200 digital valve controllers
- Change valve trim, gaskets and packing

## Topics

- Control valve terminology
- Globe valves
- Packing
- Actuators, and digital valve controllers
- Bench set
- Seat leak testing
- Ball valves
- Butterfly valves
- Eccentric disc valves

## Delivery Options

This training is also available as an Instructor Led course 1400.

## Audience

This introductory course is for valve mechanics, maintenance personnel, instrument technicians, and others who are responsible for maintaining control valves, actuators and control valve instrumentation.

## Prerequisites

Some experience in instrument calibration and in control valve maintenance, installation, and operation would be helpful.

**Fisher Valve Body & Trim Maintenance – Workshop – 1400W**  
CEUs – .8**Overview**

This is an 8-hour workshop is offered as an optional component following the 1400V remote virtual classroom event. Students will have the opportunity to perform hands on exercises on control valve bodies and actuators that reinforce the maintenance topics that were discussed during the online portion of the course. The workshop is hosted in Marshalltown, IA and a workshop facilitator will be present to assist the students with any questions they may have while performing the exercises.

**Workshops**

- Fisher easy-e™- valve trim maintenance and repair
- Fisher sliding stem valve packing replacement
- Fisher Sliding stem actuator maintenance and repair
- Fisher 657 and 667 actuator bench set
- Fisher butterfly valve maintenance and repair
- Fisher ball valve maintenance and repair
- Fisher eccentric plug valve maintenance and repair
- Fisher rotary shaft valve packing replacement
- Fisher rotary actuator maintenance and repair
- Fisher rotary valve and actuator mounting

**Audience**

This workshop is intended for any students that have completed the online component of the 1400V course and would like to gain some hands-on experience working with the control valve assemblies.

**Prerequisites**

Must have successfully completed the 1400V course.

**Fisher Control Valve Instrument Maintenance & Calibration– 1700**  
CEUs – 2.1**Overview**

This 3-day course and hands-on workshop covers the principles of operation, calibration and installation procedures for electronic and pneumatic instruments. The class will discuss maintenance procedures for Fisher sliding stem and rotary actuator assemblies. Hands on workshop exercises and lectures to discuss the operation and calibration of many Fisher instruments such as I/P transducers, pneumatic positioners, electro-pneumatic positioners, and Fisher FIELDVUE™ digital valve controllers will be covered. Students will:

- Calibrate a variety of pneumatic and electronic instruments
- Correctly perform installation procedures
- Perform basic troubleshooting of control valve instruments

**Topics**

- Actuators and bench set
- Current to pneumatic (I/P) transducers
- Instrument terminology
- Pneumatic and electro-pneumatic positioners
- Fisher FIELDVUE digital valve controller

**Delivery Options**

This training is also available as a remote virtual classroom course 1700V.

**Audience**

This course is for instrument technicians and others, responsible for pneumatic and electronic instrument calibration, installation and troubleshooting.

**Prerequisites**

Some experience in electronic and pneumatic instrument maintenance and calibration would be helpful.

**Fisher Control Valve Instrument Maintenance & Calibration – Virtual – 1700V**  
CEUs – .8**Overview**

This 8-hour remote virtual classroom course event consists of 4 virtual classroom parts, 2 hours for each part. It will explain the technical operation and maintenance of both sliding stem and rotary actuators. Also discussed will be the design, operation, and calibration principles for both sliding stem and rotary pneumatic positioners. Finally, the course will cover the basic operation and calibration principles for Fisher FIELDVUE digital valve controllers. Fisher documentation will be referenced and used to perform calibration procedures during live interactive sessions. Students also have the option to attend a corresponding hands-on workshop, 1700W, following the completion of the virtual classroom portion of this course.

- Identify and discuss operation principles of Fisher actuators
- Identify and discuss operation principles of Fisher pneumatic positioners
- Identify and discuss operation principles of Fisher I/P transducers
- Identify and discuss operation principles of Fisher FIELDVUE digital valve controllers

**Topics**

- Maintaining Fisher actuators
- Mounting and calibrating Fisher i2P-100
- Mounting and calibrating Fisher 3582 positioners
- Mounting and calibrating Fisher 3610J and 3610JP positioners
- Mounting and calibrating Fisher FIELDVUE digital valve controllers

**Delivery Options**

This training is also available as an Instructor Led course 1700.

**Audience**

This course offers a technical perspective for the working of Fisher positioners for control valve operation. The course is especially useful to anyone with responsibilities to repair, maintain, and calibrate valve positioners.

**Prerequisites**

Some experience with industrial control equipment including control valves and actuators would be helpful.

### Fisher Control Valve Instrument Maintenance & Calibration - Workshop-1700W CEUs – .8

#### Overview

This is an 8-hour workshop that is offered as an optional component following the 1700V virtual classroom event. Students will have the opportunity to perform hands-on exercises on control valve actuators and instrumentation that reinforce the maintenance topics that were discussed during the online portion of the course. The workshop is hosted in Marshalltown, IA and a workshop facilitator will be present to assist the students with any questions they may have while performing the exercises.

#### Workshops

- Fisher sliding stem actuator maintenance and repair
- Fisher 657 and 667 actuator bench set
- Fisher rotary actuator maintenance and repair
- Fisher rotary valve and actuator mounting
- Fisher I/P transducer maintenance and calibration
- Fisher 3582 positioner maintenance and calibration
- Fisher 3610J and 3610JP positioner maintenance and calibration
- Fisher FIELDVUE DVC6200 digital valve controller maintenance and calibration

#### Audience

This workshop is intended for any students that have completed the online component of the 1700V course and would like to gain some hands-on experience working with the control valve assemblies.

#### Prerequisites

Must have successfully completed the 1700V course.

### Fisher Control Valve & Instrument Troubleshooting - Introduction – 1450 CEUs – 2.1

#### Overview

This 3-day course uses a very hands-on approach for troubleshooting and correcting many common control valve problems. The class will be introduced to the practice of basic valve sizing and selection. Valve problems such as cavitation, flashing, and aerodynamic noise are also discussed as well as common solutions to these problems using different control valve trims and materials. Instrumentation topics are expanded from course 1400/1400V and 1700/1700V to include troubleshooting and advanced calibration for split ranging, non-compatible signals, or using additional instruments such as a volume booster and trip valves. Loop performance issues due to stick-slip, high friction, and instrument operation are discussed.

#### Topics

- Control loop basics
- Influences on loop performance
- Control valve selection and sizing
- Valve troubleshooting
- Actuator troubleshooting
- Instrument selection
- Basic instrument troubleshooting
- Severe service considerations

#### Audience

This course is for experienced valve mechanics and maintenance personnel, instrument technicians, and others who will benefit from a broadened perspective of control valve performance and effect on total loop operation.

#### Prerequisites

Completion of courses 1400 or 1400V (with 1400W) and 1700 or 1700V (with 1700W).

### Fisher HART based FIELDVUE Digital Valve Controllers using Emerson Field Communicators & ValveLink Mobile - Introduction – 1751 CEUs – 2.1

#### Overview

This 3-day course provides hands-on experience working with FIELDVUE digital valve controllers using an Emerson 475 or AMS Trex™ Communicator. The class will discuss basic operation and installation of the FIELDVUE digital valve controllers. Students will practice installing and mounting FIELDVUE digital valve controllers onto sliding stem and rotary control valve assemblies, as well as perform basic configuration and calibration of FIELDVUE Instruments. Troubleshooting the digital valve controller using ValveLink™ Mobile software will be performed and basic data interpretation will be introduced.

#### Topics

- FIELDVUE digital valve controller theory of operation
- FIELDVUE instrument installation
- Diagnostic troubleshooting and data interpretation using ValveLink Mobile with AD and PD tier devices

#### Audience

This course is for technicians, engineers and others responsible for installing, calibrating and basic troubleshooting Fisher FIELDVUE instruments using the Emerson Field Communicators with ValveLink Mobile.

#### Prerequisites

Some experience in instrument calibration and in control valve maintenance, installation, and operation would be helpful.

### Fisher ValveLink Solo Software for Configuration & Calibration of FIELDVUE Digital Valve Controllers– 1752 CEUs – 2.1

#### Overview

This 3-day course provides hands-on experience working with FIELDVUE digital valve controllers and ValveLink software. Students will be able to execute ValveLink software calibration and diagnostic routines, and create an instrument database.

#### Topics

- Introduction to ValveLink Solo software
- Configuration with ValveLink software
- Calibration with ValveLink software
- ValveLink software advanced and performance Tier Diagnostics
- Troubleshooting
- Introduction to diagnostic data interpretation

#### Delivery Options

This training is also available as a remote virtual classroom course training by attending courses 1760V, 1761V, 1762V, and 1763V

#### Audience

This course is for technicians, engineers and others responsible for installation, calibration and diagnostics for FIELDVUE digital valve controllers and ValveLink software. The primary focus of this course is to provide a comprehensive experience in managing digital valve controllers using the ValveLink software.

#### Prerequisites

Some experience in instrument calibration and in control valve maintenance, installation, and operation would be helpful.

### Fisher FIELDVUE Digital Valve Controllers - Virtual– 1760V CEUs - .4



#### Overview

This 4-hour remote virtual classroom course event consists of 2 virtual classroom parts, 2 hours for each part. It covers detailed operation of Fisher FIELDVUE digital valve controllers. Class discussions are centered on what individual components within a digital valve controller are, and how they can affect overall control valve performance. Common maintenance practices are detailed, and include proper care and handling of internal components, such as the I/P and Relay. Calibration procedures of the FIELDVUE DVC6200 digital valve controller will be conveyed using ValveLink™ software connected to a live device. Course focus includes:

- Identify and understand components of a digital valve controller
- Describe and demonstrate proper instrument mounting
- Connect to a live device using ValveLink Software
- Discuss and perform a guided setup routine
- Discuss and perform an auto travel calibration routine

#### Topics

- Pneumatic instrument principle overview
- Operation of a FIELDVUE digital valve controller for travel control
- Operation of a FIELDVUE digital valve controller for pressure control
- Replacing FIELDVUE digital valve controller components
- Mounting a FIELDVUE digital valve controller
- Calibrating a FIELDVUE digital valve controller

#### Audience

This course is designed for those who have the job responsibility to repair, mount, configure, and calibrate Fisher FIELDVUE digital valve controllers.

#### Prerequisites

Experience and familiarity of process control and general valve operation is recommended. Completion of course 1700 or 1700V is strongly encouraged.

### Fisher FIELDVUE Digital Valve Controller HART Communicating Tier - Virtual – 1761V CEUs - .4



#### Overview

This 4-hour remote virtual classroom course event consists of 2 virtual classroom parts, 2 hours for each part. It covers the detailed setup of the FIELDVUE digital valve controllers. The class will discuss navigating through the detailed setup menus to change device operation and configuration parameters, as well as set alerts and alarms and correctly complete the device specification sheet. Students will have access to a live FIELDVUE DVC6200 using ValveLink™ software. In conjunction with HC tiering capabilities, a basic understanding of functions and troubleshooting within ValveLink software is discussed at length. Course focus includes:

- Detailed Setup - basic page group
- Detailed Setup - alert page group
- Detailed Setup - specification sheet
- Status Monitor
- Stroke Valve Test

#### Topics

- Saving device configuration as found
- Viewing device datasets
- Comparing current datasets to historical datasets
- Restoring historical datasets
- Using status monitor
- Interpreting data from status monitor
- Performing a stroke valve test

#### Audience

This course is designed for those who have the job responsibility to perform detailed configurations and basic diagnostic troubleshooting of FIELDVUE digital valve controllers with HC tier.

#### Prerequisites

Successful completion of 1760V is required.



**Fisher FIELDVUE Digital Valve Controller Advanced Diagnostics Tier - Virtual – 1762V**  
CEUs - .4



**Overview**

This 4-hour remote virtual classroom course event consists of 2 virtual classroom part, 2 hours for each part. It introduces data collection methods for offline diagnostic testing and troubleshooting of the FIELDVUE digital valve controllers with Advanced Diagnostic (AD) Tier. Students will have access to a live FIELDVUE DVC6200 using ValveLink™ software, and will discuss the proper setup and execution of diagnostic functionality within the AD tier. Dynamic scan and step response tests will be conducted, and the class will interpret analyzed data and review the details of diagnostic graphs for each. Areas of focus for AD diagnostic functionality include:

- Step Response Test - stroking speed
- Step Response Test - 9 -point step test
- Step Response Test - performance test
- Step Response Test – 3-point ramp
- Step Response Test - supply pressure
- Step Response Test - drive signal
- Valve Signature - graph and analyzed data
- Dynamic Error Band
- Drive Signal

**Topics**

- Verifying specification sheet information
- Viewing/initializing AD related diagnostic information
- Identifying common features of diagnostic graphs
- Interpreting AD tier diagnostics

**Audience**

This course is designed for those with job responsibilities to configure and perform diagnostic tests as well as interpret diagnostic data of the FIELDVUE digital valve controller with AD tiering.

**Prerequisites**

Successful completion of 1760V and 1761V is required.

**Fisher FIELDVUE Digital Valve Controller Performance Diagnostics Tier - Virtual – 1763V**  
CEUs - .4



**Overview**

This 4-hour remote virtual classroom course event consists of 2 virtual classroom parts, 2 hours each part. It introduces data collection methods for online diagnostic testing and troubleshooting of the FIELDVUE digital valve controllers with Performance Diagnostic (PD) Tier. Students will have access to a live FIELDVUE DVC6200 device using ValveLink™ software, and will discuss the proper setup and execution of diagnostic functionality within the PD tier. Permanent tiering step-up options are discussed, including the free one-time step up to PD tier, as well as specific procedures to follow when changing a digital valve controller's diagnostic tier. Diagnostic functions of interest include:

- PD One Button
- Profiles
- Triggered Profiles
- Friction
- Friction Trends

**Topics**

- Verifying specification sheet information
- Running a PD One Button Test
- Viewing/analyzing PD related diagnostic information
- Configuring scheduler to run diagnostics
- Configuring/Activating trending and network alert scan functions
- Understanding digital valve controller diagnostic tiering levels

**Audience**

This course is designed for those with job responsibilities to perform and interpret online diagnostic tests associated with the FIELDVUE digital valve controller with PD tiering.

**Prerequisites**

Successful completion of 176V, 1761V, and 1762V is required.

**Fisher FOUNDATION Fieldbus FIELDVUE Digital Valve Controller – 7036**  
CEUs – 2.1

**Overview**

This 3-day course reviews the role and function of control valve positioners followed by a series of hands-on exercises to disassemble, inspect, assemble, install, and commission a FOUNDATION fieldbus FIELDVUE digital valve controller. During commissioning, students will learn the basics of the FOUNDATION fieldbus protocol, the role of function blocks, addressing, modes and status. Students will configure, calibrate, and commission devices using Emerson Communicator and ValveLink™ Solo software. Hands-on exercises also teach students how to perform detailed setup routines and how to run and collect data for various ValveLink software diagnostics.

**Topics**

- Positioner Basics
- FOUNDATION fieldbus overview
- FIELDVUE digital valve controller installation and mounting
- Modes and status
- Configuration and calibration with the 475 or AMS Trex™ Communicator and ValveLink Mobile
- ValveLink™ software guided Setup /Detailed Setup
- Tuning
- Tag management
- Pressure control
- ValveLink software diagnostics
- FIELDVUE instrument troubleshooting

**Audience**

This course teaches technicians and engineers the basics of FOUNDATION fieldbus digital valve controller installation, configuration, calibration, and troubleshooting.

**Prerequisites**

Some experience in instrument calibration and in control valve maintenance, installation, and operation would be helpful.

### Fisher Diagnostic Data Interpretation Using ValveLink Software for FIELDVUE– 1759 CEUs – 2.1

#### Overview

This 3-day course uses practical exercises and discussions to teach the student to interpret and analyze diagnostic data obtained using FIELDVUE digital valve controllers and ValveLink software. Students will perform diagnostic tests on a variety of valve/actuator combinations and use the data to determine bench set, dynamic error band, seat load, spring rate and other pertinent parameters. Students will also perform comparison tests on valve/actuator assemblies containing configuration or operating flaws and use the data for troubleshooting purposes.

#### Topics

- Review of ValveLink software diagnostic tests
- Data interpretation
- Troubleshooting techniques
- Comparison testing techniques
- Performance diagnostics

#### Audience

This course is for technicians, engineers and others responsible to collect and interpret valve diagnostic tests performed using ValveLink™ software.

#### Prerequisites

Students must have completed one of the following: 1751, 1752, 7036, or 1760V Series (1760V, 1761V, 1762V, 1763V).

### Fisher Nuclear Data Acquisition & Interpretation - Introduction– 1427 CEUs – 2.8

#### Overview

This 4 1/2-day course uses lecture and hands-on labs to teach students to properly acquire and analyze diagnostic data using the QUIKLOOK 3-FS valve diagnostic system. This course teaches proper setup of hardware and software, accurate entry of data, and other procedures that are required to ensure accuracy when acquiring data. Also covered are good techniques in interpreting and analyzing the collected data. Actual case histories form a basis for teaching interpretation skills. Students will test and diagnose a sampling of valves in which specific problems have been introduced. Students who complete this will:

- Navigate features of QUIKLOOK 3-FS software
- Correctly mount sensors and related valve diagnostic system hardware on standard air-operated valves (AOV's)

### Fisher Nuclear Data Acquisition & Interpretation – Introduction – 1427 – Continued...

- Enter valve, instrument, and actuator data
- Correctly enter test parameters
- Perform various step and stroking tests to collect diagnostic data
- Analyze typical and atypical, valve diagnostic data
- Create/view standard valve diagnostic system reports

#### Topics

- QUIKLOOK 3-FS valve diagnostic system hardware/software overview
- In-depth software navigation
- Setup and testing techniques
- Data entry & test criteria best practices
- Data management
- Report generation/expected results
- Background software routines and equations for the analysis numbers
- Case study analysis- including discussions of valve/instrument/installation problems
- Laboratory activities/support

#### Audience

This course is designed for personnel who will perform and interpret control valve diagnostic testing using a QUIKLOOK 3-FS valve diagnostic system.

#### Prerequisites

Knowledge and experience of valves, actuators, control valve instrumentation operation and basic maintenance. Completion of 1400 or 1400V, 1700 or 1700V, and 1450 courses is recommended but not required.

### Fisher Nuclear Data Acquisition & Interpretation - Advanced – 1428 CEUs – 2.1

#### Overview

This 3-day course starts with a brief review of QUIKLOOK 3-FS valve diagnostic system software confirms student familiarity with test setups, pressure and travel channels, and the objectives of all available test procedures. The course is based on a structured combination of lectures and hands-on labs to teach students how to identify problems in control valve assemblies. Emphasis is placed on determining and confirming overall control assembly: I/P, positioner, actuator, and valve body. Report generation and some field tips are also presented. To capitalize on learning from shared experiences, students are encouraged to bring in test data from an interesting scenario or a

### Fisher Nuclear Data Acquisition & Interpretation - Advanced – 1428 – Continued...

current problem. Those who complete this course will:

- Select the appropriate QUIKLOOK 3-FS valve diagnostic system test for a given scenario.
- Understand the impact of scan rates on the appearance and interpretation of acquired data.
- Analyze valve diagnostic test data to determine overall control valve health by evaluating the condition of the various components of the assembly.
- Identify multiple anomalies in a single assembly.
- Use QUIKLOOK 3-FS valve diagnostic system functions to generate quick reports.
- Learn how to perform a step test on a discrete valve without interrupting power to the valve.

#### Topics

- Review of various valve diagnostic tests and specific objectives of each
- Impact of test configuration errors
- Data interpretation from tests of “bugged” valve assemblies
- Multiple anomalies found in control valves
- Exporting data
- Generating quick reports
- Interpretation of difficult to detect control valve problems

#### Audience

This course is designed for personnel who are responsible for interpreting plots and other diagnostic data that is acquired with the QUIKLOOK 3-FS valve diagnostic system. This course focuses on data interpretation. Data acquisition is taught in course 1427.

#### Prerequisites

A pre-test and a control valve awareness test are used to confirm applicant readiness. Course 1427 and a minimum of six months of diagnostic testing with the QUIKLOOK 3-FS valve diagnostic system.

## Typical Technicians Learning Path

**Rosemount - Process Measurement Pressure & Temperature Products – 2326**  
 CEUs - 2.18
**Overview**

This 4-day course explains how pressure and temperature transmitters function and how they are installed and calibrated. It emphasizes installation, proper set-up and calibration of Analog and HART® Pressure and Temperature Transmitters. The course uses lectures and labs to teach the students. Those who complete this class will be able to:

- correctly perform installation and setup procedures
- properly configure transmitters
- properly calibrate transmitters
- perform basic troubleshooting

**Topics**

- Basic 4-20 mA Loop Setup
- Pressure Sensors
- Temperature Sensors (TC, RTD)
- Analog Transmitters (1151)
- HART® Communication
- Field Communicator
- Pressure Transmitters
- Temperature Transmitters
- Using AMS Device Manager to Configure and Calibrate Transmitters
- Installation
- Configuration
- Calibration
- Troubleshooting

**Audience**

This course is intended for technicians, engineers and other plant personnel who need to know installation, calibration, maintenance and troubleshooting of measurement instrumentation.

**Prerequisites**

Some experience in instrument calibration, maintenance, installation and operation would be helpful.

**Rosemount - Process Measurement DP Flow Products – 2327**  
 CEUs - 1.4
**Overview**

This 2-day course explains how DP flow instruments function and how they are installed and calibrated. It emphasizes installation, proper setup and calibration/verification of DP flow instruments. The course uses lectures and labs to teach the students. Those who complete this class will be able to:

- correctly install, configure, calibrate multivariable DP Flow Transmitters
- perform DP Flow troubleshooting

**Topics**

- Basic DP Flow Fundamentals
- DP Flow Sizing Calculations
- Multivariable Flow Transmitters
- AMS Device Manager with Engineering Assistant Snap-ON (3095)
- Engineering Assistant for 3051SMV
- Field Communicator
- Test Equipment Selection
- Installation
- Configuration
- Calibration /Verification
- Troubleshooting DP Flow Installations

**Audience**

This course is intended for technicians, engineers and other plant personnel who need to know installation, calibration, verification, maintenance and troubleshooting of DP flow measurement instrumentation.

**Prerequisites**

Some experience in instrument calibration/verification, maintenance, installation and operation would be helpful.

### Rosemount Process Measurement Level Products – 2333 CEUs - 2.1

#### Overview

This 3-day course explains how level instruments function and how they are installed calibrated/verified. It emphasizes installation, proper setup and calibration/verification of level instruments. The course uses lectures and labs to teach the students. Those who complete this class will be able to:

- correctly install, configure, calibrate/verify, perform maintenance and troubleshooting on the following:
  - DP Level Transmitters
  - Guided Wave Radar Transmitters
  - Non-contacting Radar Transmitters
- Use Radar software for configuration and troubleshooting

#### Topics

- DP Level Fundamentals
- Electronic Remote Sensors
- Radar Applications
- Radar Instruments
- Radar PC Software
- Field Communicator
- Test Equipment Selection
- Installation
- Configuration
- Calibration /Verification
- Troubleshooting

#### Audience

This course is intended for technicians, engineers and other plant personnel who need to know installation, calibration, maintenance and troubleshooting of level measurement instrumentation.

#### Prerequisites

Experience in instrument calibration, maintenance, installation and operation would be helpful.

### AMS Device Manager with Rosemount HART Instruments – 7021 CEUs - 2.1

#### Overview

Learn the installation, calibration, maintenance, and troubleshooting of measurement instrumentation using AMS Device Manager. This 3-day course teaches maintenance and calibration of measurement devices using AMS Device Manager software to communicate and track information. The student will learn how pressure and temperature transmitters function, are installed, and calibrated using AMS Device Manager. The course uses hands-on training, labs, and lecture to teach the student how to:

- configure and use AMS Device Manager correctly perform transmitter installation and setup procedures
- properly configure HART® transmitters
- properly calibrate transmitters
- perform basic troubleshooting-transmitters

#### Topics

- Configuring and Using AMS Device Manager
- Viewing and Modifying Devices
- Creating a Plant Database Hierarchy and Adding Devices
- AMS Device Manager Browser Functions
- Audit Trail
- HART® Communication
- HART Transmitters (3051C, 3144P)
- Test Equipment Selection
- Transmitter Installation and Configuration
- Transmitter Calibration
- AMS Calibration Assistant
- Intelligent Calibrators
- Transmitter Troubleshooting

#### Audience

The hands-on focus is on skills required by engineers, technicians, or others that are new to the plant or instrument environment.

## Typical Engineering Training Path

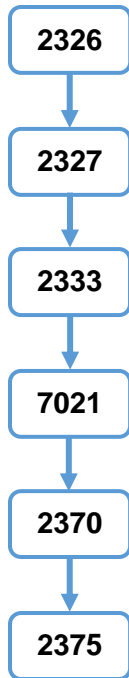
**Rosemount Process Measurement Pressure & Temperature Products – 2326**  
 CEUs - 2.18
**Overview**

This 4-day course explains how pressure and temperature transmitters function and how they are installed and calibrated. It emphasizes installation, proper set-up and calibration of Analog and HART® Pressure and Temperature Transmitters. The course uses lectures and labs to teach the students. Those who complete this class will be able to:

- correctly perform installation and setup procedures
- properly configure transmitters
- properly calibrate transmitters
- perform basic troubleshooting

**Topics**

- Basic 4-20 mA Loop Setup
- Pressure Sensors
- Temperature Sensors (TC, RTD)
- Analog Transmitters (1151)
- HART® Communication
- Field Communicator
- Pressure Transmitters
- Temperature Transmitters
- Using AMS Device Manager to Configure and Calibrate Transmitters
- Installation
- Configuration
- Calibration
- Troubleshooting

**Audience**

This course is intended for technicians, engineers and other plant personnel who need to know installation, calibration, maintenance and troubleshooting of measurement instrumentation.

**Prerequisites**

Some experience in instrument calibration, maintenance, installation and operation would be helpful.

**Rosemount - Process Measurement Products (DP Flow) - II – 2327**  
 CEUs - 1.4
**Overview**

This 2-day course explains how DP flow instruments function and how they are installed and calibrated. It emphasizes installation, proper setup and calibration/verification of DP flow instruments. The course uses lectures and labs to teach the students. Those who complete this class will be able to:

- correctly install configure, calibrate multivariable DP Flow Transmitters
- perform DP Flow troubleshooting

**Topics**

- Basic DP Flow Fundamentals
- DP Flow Sizing Calculations
- Multivariable Flow Transmitters
- AMS Device Manager with Engineering Assistant Snap-ON (3095)
- Engineering Assistant for 3051SMV
- Field Communicator
- Test Equipment Selection
- Installation
- Configuration
- Calibration /Verification
- Troubleshooting DP Flow Installations

**Audience**

This course is intended for technicians, engineers and other plant personnel who need to know installation, calibration, verification, maintenance and troubleshooting of DP flow measurement instrumentation.

**Prerequisites**

Some experience in instrument calibration/ verification, maintenance, installation and operation would be helpful.



### Rosemount Process Measurement Level Products – 2333 CEUs - 2.1

#### Overview

This 3-day course explains how level instruments function and how they are installed calibrated/verified. It emphasizes installation, proper setup and calibration/verification of level instruments. The course uses lectures and labs to teach the students. Those who complete this class will be able to:

- correctly install, configure, calibrate/verify, perform maintenance and troubleshooting on the following:
  - DP Level Transmitters
  - Guided Wave Radar Transmitters
  - Non-contacting Radar Transmitters
- Use Radar software for configuration and troubleshooting

#### Topics

- DP Level Fundamentals
- Electronic Remote Sensors
- Radar Applications
- Radar Instruments
- Radar PC Software
- Field Communicator
- Test Equipment Selection
- Installation
- Configuration
- Calibration /Verification
- Troubleshooting

#### Audience

This course is intended for technicians, engineers and other plant personnel who need to know installation, calibration, maintenance and troubleshooting of level measurement instrumentation.

#### Prerequisites

Experience in instrument calibration, maintenance, installation and operation would be helpful.

### AMS Device Manager with Rosemount HART Instruments– 7021 CEUs - 2.1

#### Overview

Learn the installation, calibration, maintenance, and troubleshooting of measurement instrumentation using AMS Device Manager. This 3-day course teaches maintenance and calibration of measurement devices using AMS Device Manager software to communicate and track information. The student will learn how pressure and temperature transmitters function, are installed, and calibrated using AMS Device Manager. The course uses hands-on training, labs, and lecture to teach the student how to:

- configure and use AMS Device Manager correctly perform transmitter installation and setup procedures
- properly configure HART@ transmitters
- properly calibrate transmitters
- perform basic troubleshooting-transmitters

#### Topics

- Configuring and Using AMS Device Manager
- Viewing and Modifying Devices
- Creating a Plant Database Hierarchy and Adding Devices
- AMS Device Manager Browser Functions
- Audit Trail
- HART@ Communication
- HART Transmitters (3051C, 3144P)
- Test Equipment Selection
- Transmitter Installation and Configuration
- Transmitter Calibration
- AMS Calibration Assistant
- Intelligent Calibrators
- Transmitter Troubleshooting

#### Audience

The hands-on focus is on skills required by engineers, technicians, or others that are new to the plant or instrument environment.

### Rosemount Fieldbus Measurement Instruments – 2370 CEUs - 2.1

#### Overview

This 3-day class covers the integration of FOUNDATION™ fieldbus compliant measurement devices using the Field Communicator, Emerson USB Fieldbus Modem, AMS Device Manager, and other hosts.

Upon completion of this course students will be able to: install, configure, calibrate, and troubleshoot Rosemount Fieldbus devices which include the 3051C and 3051S Pressure Transmitters, 644, 3144P and 848 Temperature transmitters 5600, 5400 and 5300 Radar Level Transmitters, and 752 Indicator.

#### Topics

- FOUNDATION™ fieldbus Overview
- Fieldbus: Wiring/Segment Design/Function Blocks
- Field Communicator Operation
- AMS Device Manager Operation
- Theory of Operation, Installation, Configuration, Maintenance, Calibration and Troubleshooting on the following:
  - 3051C Pressure Transmitter
  - 3051S Pressure Transmitter
  - 3144P, and 644 Temperature Transmitters
  - 848 Temperature Transmitter
  - 5600, 5400 and 5300 Radar Level Transmitters
  - 752 Fieldbus Indicator

Note: Course may be conducted using other Fieldbus Hosts, such as AMS Device Manager.

#### Audience

This course is for individuals responsible for installing, configuring, calibrating, and troubleshooting FOUNDATION™ fieldbus measurement devices.

#### Prerequisites

Experience in instrument calibration, maintenance, installation, and operation would be helpful.

**Rosemount Wireless Self Organizing  
Network with Host Integration – 2375  
CEUs - 1.4**

**Overview**

This 2-day course explains how Self Organizing Wireless Networks function and how they are installed, setup, configured and integrated. It emphasizes planning, proper installation and startup, configuration, maintenance, and integration. The course uses lectures and labs to maximize the hands on experience and teach the students. Students who complete this course will:

- correctly install and setup the 1420 & 1410 Wireless Gateway
- properly install and configure Wireless Transmitters
- properly integrate Host interfaces to the Wireless Gateway

**Topics**

- How Self Organizing Networks Function
- Self Organizing Networks Best Practices
- Network Components
- 1420 & 1410 Installation and Setup
- Network Parameters
- Wireless Transmitters Installation, Configuration, Maintenance and Calibration
- THUM Installation, Wiring and Configuration
- Integrating and Operating AMS Device Manager with the 1420 Wireless Gateway
- Operation of AMS Wireless SNAP-ON
- Modbus Serial Integration
- Modbus TCP Integration
- OPC Integration

**Audience**

This course is intended for technicians, engineers and other plant personnel who need to know how to design, install, setup, configure, maintain and troubleshoot Wireless Self Organizing Networks and their components.

**Prerequisites**

Some experience in Wireless Networks and Host integration would be helpful.

# Educational Services

Maximize Your Investment!



## Rosemount

### Measurement Instrumentation

188



#### Rosemount Measurement

Wireless: 2375 2376 e2977

AMS Device Manager: 7020 7021 E2300

Interactive Plant Environment: 2808 2821 2898 2829 2812 2896 2875

Flow: 2340 2340A 2341 2341A C6000 C6001 C6002 C6003 C6004 2339SM 2339SV 2383 2394 2384 2387



#### Rosemount Tank Gauging

RTG101 RTG102



#### Rosemount Analytical

Rosemount Gas Analyzer: 2110 2157 2153 2170 2171

#### Rosemount Gas Chromatographs

R4100 R4210 R4105 R4170 R4212 R4213 R4214 R4215 R4311 R4315 R4316 e4070



#### Rosemount Liquid

2200 2204 2201 2205 E2601 E2602

### Rosemount Pressure Transmitters, Interactive Plant Environment – 2808 CEUs - 1.4

#### Overview

This 2-day course combines lectures with bench-top labs and uses the interactive plant for scenario based training. Target students are individuals responsible for the installation, configuration, calibration and maintenance of the Rosemount Pressure transmitters. Students shall apply classroom knowledge directly to the interactive plant scenario labs. Be ready to learn in a "real world" plant environment.

#### Topics

- Identify Transmitter Parts and Functionality
- Explain the Principles of Operation of Pressure Transmitters
- Configure, Calibrate and Test Pressure Transmitters using the Field Communicator
- Properly Install and Troubleshoot Pressure Transmitters
- Students shall ensure proper PPE and safety measures while working on the plant.

### Rosemount Temperature Transmitters, Interactive Plant Environment – 2821 CEUs - 0.7

#### Overview

This 1-day course combines lectures with bench-top labs and uses the interactive plant for scenario based training. Students shall apply classroom knowledge directly to the interactive plant scenario labs. Be ready to learn in a "real world" plant environment.

#### Topics

- Identify Transmitter Parts and Functionality
- Explain the Principles of Operation of Temperature Transmitters
- Configure, Calibrate and Test Temperature Transmitters using the Field Communicator
- Properly Install and Troubleshoot Temperature Transmitters.
- Students shall ensure proper PPE and safety measures while working on the plant.

#### Audience

Target students are individuals responsible for the installation, configuration, calibration and maintenance of the Rosemount Temperature transmitters.

### Rosemount 3051 Pressure & 3144P Temperature Transmitters, Interactive Plant Environment – 2898 CEUs - 2.1

#### Overview

This 3-day course combines lectures with bench-top labs and uses the interactive plant for scenario based training. Target students are individuals responsible for the installation, configuration, calibration and maintenance of the Rosemount Pressure and Temperature transmitters. Students shall apply classroom knowledge directly to the interactive plant scenario labs. Be ready to learn in a "real world" plant environment.

#### Topics

- Explain the Difference between HART® & Analog Transmitters
- Identify Transmitter Parts and Functionality
- Explain the Principles of Operation of Pressure and Temperature Transmitters
- Configure, Calibrate and Test Pressure and Temperature Transmitters using the Field Communicator
- Properly Install and Troubleshoot Pressure and Temperature Transmitters.
- Students shall ensure proper PPE and safety measures while working on the plant.

### Rosemount Pressure, Temperature, MultiVariable Flow Transmitters, Interactive Plant Environment– 2829 CEUs - 2.8

#### Overview

This 4-day course combines lectures with bench-top labs and uses the interactive plant for scenario-based training. Target students are individuals responsible for the installation, configuration, calibration and maintenance of the Rosemount Pressure, Temperature, and Multi-Variable Flow transmitters. Students shall apply classroom knowledge directly to the interactive plant scenario labs. Be ready to learn in a "real world" plant environment.

#### Topics

- identify transmitter parts and functionality
- explain the principles of operation of the transmitters
- configure, calibrate and test transmitters using the field communicator, AMS Device Manager, and Engineering Assistant software
- configure the compensated flow parameters
- properly install and troubleshoot pressure, temperatures and multi-variable flow transmitters

#### Audience

Target students are individuals responsible for the installation, configuration, calibration and maintenance of the Rosemount Pressure, Temperature, and Multi-Variable Flow transmitters.

**Rosemount MultiVariable Flow Transmitter, Interactive Plant Environment – 2812**  
CEUs - 1.1

**Overview**

This 1-1/2-day course combines lectures with bench-top labs and uses the interactive plant for scenario based training. Students shall apply classroom knowledge directly to the interactive plant scenario labs. Be ready to learn in a "real world" plant environment.

**Topics**

- Identify Transmitter Parts and Functionality
- Explain the Principles of Operation of the Transmitters
- Configure, Calibrate and Test Transmitters using the Field Communicator, AMS Device Manager, and Engineering Assistant Software
- Configure the Compensated Flow Parameters
- Properly Install and Troubleshoot Pressure, Temperatures and Multi-Variable Flow Transmitters
- Students shall ensure proper PPE and safety measures while working on the plant.

**Audience**

Target students are individuals responsible for the installation, configuration, calibration and maintenance of the Rosemount 3051SMV Multi-Variable Flow transmitters.

**Rosemount Guided Wave & Non-Contacting Radar Level Transmitters, Interactive Plant Environment – 2896**  
CEUs - 1.4

**Overview**

This 2-day course combines lectures with bench-top labs and uses the interactive plant for scenario based training. Students shall apply classroom knowledge directly to the interactive plant scenario labs. Be ready to learn in a "real world" plant environment.

**Topics**

- Identify Transmitter Parts and Functionality
- Explain the Principles of Operation the Transmitters
- Configure, Calibrate/Verify and Test Radar Level Transmitters using the Field Communicator, Radar Master Software
- Understand How to Setup the Radars in Different Applications
- Properly Install and Troubleshoot the 5300 & 5400 Transmitters and their Applications

Students shall ensure proper PPE and safety measures while working on the plant.

**Audience**

Target students are individuals responsible for the installation, configuration, calibration and maintenance of the Rosemount 5300 & 5400 Radar Level transmitters.

**Rosemount Wireless Self Organizing Networks, Interactive Plant Environment – 2875**

CEUs: 2.5

**Overview**

This 3.5-day course combines classroom theory with hands-on labs. Learn by doing with the Interactive Plant Environment. This unique training setting provides a safe and realistic environment to elevate skills and knowledge through direct interaction with live wireless networks and devices. This course is designed for engineers and technicians whose responsibilities include: startup, configuration, troubleshooting, and host integration of wireless networks and devices. Be ready to learn in a "real world" plant environment.

**Topics**

After completing this course, you will be able to:

- Perform a wireless network planning walkthrough
- Know and operate wireless network planning tools
- Install a wireless network following wireless best practices
- Installation and configuration of wireless devices
- Installation and configuration of THUMS
- Troubleshoot Wireless networks, performance and connectivity
- Connect and prove proper MODBUS communications
- Connect and prove proper OPC communications

**Audience**

Engineers and Instrument Technicians

**Prerequisites**

Some experience in Wireless Networks and Host Integration would be helpful, but not required. Some basic instrument knowledge would be beneficial.



### Rosemount Wireless Self Organizing Network with Host Integration – 2375 CEUs - 1.4

#### Overview

This 2-day course explains how Self Organizing Wireless Networks function and how they are installed, setup, configured and integrated. It emphasizes planning, proper installation and startup, configuration, maintenance, and integration. The course uses lectures and labs to maximize the hands on experience and teach the students. Students who complete this course will:

- correctly install and setup the 1420 & 1410 Wireless Gateway
- properly install and configure Wireless Transmitters
- properly integrate Host interfaces to the Wireless Gateway

#### Topics

- How Self Organizing Networks Function
- Self Organizing Networks Best Practices
- Network Components
- 1420 & 1410 Installation and Setup
- Network Parameters
- Wireless Transmitters Installation, Configuration, Maintenance and Calibration
- THUM Installation, Wiring and Configuration
- Integrating and Operating AMS Device Manager with the 1420 Wireless Gateway
- Operation of AMS Wireless SNAP-ON
- Modbus Serial Integration
- Modbus TCP Integration
- OPC Integration

#### Audience

This course is intended for technicians, engineers and other plant personnel who need to know how to design, install, setup, configure, maintain and troubleshoot Wireless Self Organizing Networks and their components.

#### Prerequisites

Some experience in Wireless Networks and Host integration would be helpful.

### Rosemount Wireless Self Organizing Network – 2376 CEUs - 0.7

#### Overview

This 1-day course explains how Self Organizing Wireless Networks function and how they are installed, setup, and configured. It emphasizes planning, proper installation and startup, configuration and maintenance. The course uses lectures and labs to maximize the hands on experience and teach the students.

Students who complete this course will:

- correctly install and setup the 1420 & 1410 Wireless Gateway
- properly install and configure Wireless Transmitters

#### Topics

- How Self Organizing Networks Function
- Self Organizing Networks Best Practices
- Network Components
- 1420 & 1410 Installation and Setup
- Network Parameters
- Wireless Transmitters Installation, Configuration, Maintenance and Calibration
- THUM Installation, Wiring, Configuration
- Integrating and Operating AMS Device Manager with the 1420 & 1410 Wireless Gateway and Wireless Devices

#### Audience

This course is intended for technicians, engineers and other plant personnel who need to know how to install, setup, configure, maintain and troubleshoot Wireless Self Organizing Networks and their components.

#### Prerequisites

Some experience in Wireless Networks and Host integration would be helpful. Completion of the Wireless classes on Plantweb University would be beneficial.

### Rosemount Wireless Pressure Gauge - e2977 CEUs - 0.3



#### Overview

The Wireless Pressure Gauge on-demand course offers a comprehensive set of "How to" lessons designed to bring an interactive learning environment over the internet directly to you at any time. By the end of the course, you will know how to specify, install, configure, maintain, and troubleshoot the gauge. In addition, the course provides learning to maximize the use of the Wireless Pressure Gauge's new capabilities.

**AMS Device Manager – 7020**  
CEUs - 2.1**Overview**

Completing 3-days of AMS Device Manager hands-on instructor assisted training modules and exercises, provides the quickest route to your productive use of this predictive maintenance application.

**Topics**

- Viewing and Modifying Devices
- Creating a Plant Database Hierarchy and Adding Devices
- Using the Field Communicator with AMS Device Manager
- Using the AMS Device Manager Browser Functions
- Audit Trail
- Calibrating Device - Calibration Assistant
- Configuring and Monitoring System Alerts
- Installing an AMS Device Manager Server Plus Standalone
- Starting AMS Device Manager for the First Time
- Network Communication Interface Setup
- AMS Device Manager Database Management
- Installing a Distributed System
- Installing Device Types from Media
- MV Engineering Assistant SNAP-ON Application
- QuickCheck™ SNAP-ON Application
- AMS Device Manager OPC Server and the Matrikon OPC Explorer
- AMS Device Manager Web Services
- AlertTrack™ SNAP-ON Application
- Wireless SNAP-ON Application

**Audience**

This course is intended for technicians and engineers who need to configure and use AMS Device Manager.

**AMS Device Manager with Rosemount HART Instruments– 7021**  
CEUs - 2.1**Overview**

Learn the installation, calibration, maintenance, and troubleshooting of measurement instrumentation using AMS Device Manager. This 3-day course teaches maintenance and calibration of measurement devices using AMS Device Manager software to communicate and track information. The student will learn how pressure and temperature transmitters function, are installed, and calibrated using AMS Device Manager. The course uses hands-on training, labs, and lecture to teach the student how to:

- configure and use AMS Device Manager correctly perform transmitter installation and setup procedures
- properly configure HART® transmitters
- properly calibrate transmitters
- perform basic troubleshooting-transmitters

**Topics**

- Configuring and Using AMS Device Manager
- Viewing and Modifying Devices
- Creating a Plant Database Hierarchy and Adding Devices
- AMS Device Manager Browser Functions
- Audit Trail
- HART® Communication
- HART Transmitters (3051C, 3144P)
- Test Equipment Selection
- Transmitter Installation and Configuration
- Transmitter Calibration
- AMS Calibration Assistant
- Intelligent Calibrators
- Transmitter Troubleshooting

**Audience**

The hands-on focus is on skills required by engineers, technicians, or others that are new to the plant or instrument environment.

**AMS Trex Device Communicator - e2300**  
CEUs – 0.1**Overview**

E2300 AMS Trex Device Communicator is an introductory course with lessons on theory of operation, model number and spare part selection, communicator configuration, connecting, communicating, and/or powering HART®, FOUNDATION™ Fieldbus, and wireless devices and positioners, unit maintenance, and troubleshooting the unit and device connectivity.

### Rosemount 8700 Series Smart Magnetic Flowmeter – Intermediate - 2340 CEUs - 0.7

#### Overview

This 1-day course consists of a blend of lectures and hands-on exercises that cover how to install, configure, and maintain the Rosemount 8700 Series Magnetic Flowmeter Systems composed of the Model 8712 and 8732 transmitters and the 8705 Flanged and 8711 Wafer Sensors. The students will learn the operation and capabilities of Local Operator Interface (LOI), 475 Field Communicator, and/or AMS Device Manager and how to use these tools to perform configuration. Common issues encountered and troubleshooting techniques will also be covered.

#### Topics

- Explain the Difference and Capabilities of the Rosemount 8700 Series Magnetic Flowmeters
- Identify Transmitter and Sensor Parts and Explain Functionality
- Explain Faraday's Law and the Principles of Operation of Magnetic Flowmeter System
- Configure and Test Transmitters Using the LOI, Field Communicator, or AMS Device Manager
- Properly Install/Troubleshoot the Rosemount Magnetic Flowmeter System

#### Audience

This course is intended for anyone that is involved with properly installing, wiring, configuring and troubleshooting a Rosemount 8700 Series Magnetic flowmeter. Typical job functions include: maintenance technicians, instrument technicians and instrumentation engineers.

#### Prerequisites

Knowledge of basic flow fundamentals and instrumentation.

### Rosemount Smart Magnetic Flowmeter with AMS Device Manager - Intermediate - 2340A CEUs - 0.7

#### Overview

This 1-day course consists of a blend of lectures and hands-on exercises that cover how to install, configure, and maintain the Rosemount 8700 Series Magnetic Flowmeter Systems composed of the Model 8712 and 8732 transmitters and the 8705 Flanged and 8711 Wafer Sensors. The students will learn the operation and capabilities of AMS Device Manager and how to use this tool to perform configuration. Common issues encountered and troubleshooting techniques will also be covered.

#### Topics

- Explain the Difference and Capabilities of the Rosemount 8700 Series Magnetic Flowmeters
- Identify Transmitter and Sensor Parts and Explain Functionality
- Explain Faraday's Law and the Principles of Operation of Magnetic Flowmeter system
- Configure and Test Transmitters Using AMS Device Manager
- Properly Install/Troubleshoot the Rosemount Magnetic Flowmeter System

#### Audience

This course is intended for anyone that is involved with properly installing, wiring, configuring and troubleshooting a Rosemount 8700 Series Magnetic flowmeter. Typical job functions include: maintenance technicians, instrument technicians, and instrumentation engineers.

#### Prerequisites

None required. However, basic understanding of the fundamentals of flow measurement, electricity, analog and frequency signal processing are assumed.

### Rosemount 8800 Series Smart Vortex Flowmeter- Intermediate - 2341 CEUs - 0.7

#### Overview

This 1-day course consists of a blend of lectures and hands-on exercises that cover how to install, configure, and maintain the Rosemount 8800 Series Smart Vortex flowmeter systems. The students will learn the operation and capabilities of the Local Operator Interface and HC475 Field Communicator and how to use these tools to perform configuration. Common issues encountered and troubleshooting techniques will also be covered.

#### Topics

- Explain the Differences and Capabilities of the Rosemount 8800 Series Vortex Flowmeters
- Explain the von Karman Effect and the Principles of Operation of Vortex Flowmeters.
- Identify Vortex Parts and Explain Functionality
- Configure and Test Transmitters using Field Communicator or AMS Device Manager
- Properly Install and Troubleshoot the Rosemount 8800 Series Vortex Flowmeter System

#### Audience

This course is intended for anyone that is involved with properly installing, wiring, configuring and troubleshooting a Rosemount 8800 Series Vortex Flowmeter. Typical job functions include: maintenance technicians, instrument technicians, and instrument engineers.

#### Prerequisites

None required. However, basic understanding of the fundamentals of flow measurement, electricity, analog & frequency signal processing are assumed.

### Rosemount 8800 Series Smart Vortex Flowmeters with AMS Device Manager - Intermediate - 2341A CEUs - 0.7

#### Overview

This 1-day course consists of a blend of lectures and hands-on exercises that cover how to install, configure, and maintain the Rosemount 8800 Series Vortex flowmeter systems. The students will learn how to use AMS Device Manager to perform configuration. Common issues encountered and troubleshooting techniques will also be covered.

#### Topics

- Explain the Differences and Capabilities of the Rosemount 8800 Series Vortex Flowmeters
- Explain the von Karman Effect and Principles of Operation of Vortex Flowmeters
- Identify Vortex Parts and Explain Functionality
- Configure and Test Transmitters using the AMS Device Manager
- Properly Install and Troubleshoot the Rosemount 8800 Series Vortex Flowmeter System

#### Audience

This course is intended for anyone that is involved with properly installing, wiring, configuring and troubleshooting a Rosemount 8800 Series Vortex Flowmeter. Typical job functions include; maintenance technicians, instrument technicians, and instrument engineers.

#### Prerequisites

None required. However, basic understanding of the fundamentals of flow measurement, electricity, analog & frequency signal processing are assumed.

### Rosemount Vortex Online Instrument & Electrical - c6000

#### Overview

This curriculum group contains c6001, c6002, c6003 and c6004. This entire curriculum may be purchased at a discounted price, or each section of the curriculum may be purchased individually. Unlimited access for 3 months. Duration: 3 Hours.

#### Topics

- theory
- product offering and model selection
- vortex sizing
- installation best practices for piping, mounting, remote electronics and wiring
- device configuration for the 475 HART® Field Communicator and the AMS Device Manager
- using the configuration tools
- electronics, sensor and process troubleshooting
- vibration, mass balancing, and filter troubleshooting.

### Rosemount Vortex Theory & Specification - c6001

#### Overview

This curriculum is part of the Vortex Online Instrument and Electrical (I81E) Technician Training. It may be purchased individually or with the c6000 curriculum. \$95 per student - unlimited access for 3 months. Duration: .5 hour

#### Topics

- theory of operation
- overview of the vortex meter product offering
- model selection
- discuss vortex sizing

### Rosemount Vortex Installation Best Practices- c6002

#### Overview

This curriculum is part of the Vortex Online Instrument and Electrical (I81E) Technician Training. It may be purchased individually or with the c6000 curriculum. Unlimited access for 3 months. Duration: .5HR

#### Topics

- piping requirements
- mounting
- remote electronics
- wiring

### Rosemount Vortex Device Configuration & Using Configuration Tools- c6003

#### Overview

This curriculum is part of the Vortex Online Instrument and Electrical (I81E) Technician Training. It may be purchased individually or with the c6000 curriculum. Unlimited access for 3 months. Duration: 1 HR

#### Topics

- key parameters for a basic vortex configuration
- how to use AMS and the Field Communicator to configure an 8800D Vortex meter
- advanced configuration for special units of measure, base volume units - density ratio, pulse output, totalizer, display variables and saturated steam using the MTA option

### Rosemount Vortex Troubleshooting- c6004

#### Overview

This curriculum is part of the Vortex Online Instrument and Electrical (I81E) Technician Training. It may be purchased individually or with the c6000 curriculum. Unlimited access for 3 months. Duration: 1HR

#### Topics

- troubleshooting scenarios
- electronics, sensor and process troubleshooting
- vibration, mass balancing and filtering troubleshooting

### Rosemount 8700 Series Smart Magnetic Flowmeter – Introduction - 2339SM CEUs - 0.4

#### Overview

This 1/2-day field class is a condensed version of the 2340 course briefly reviewing the theory of operation, meter components and installation. The focus of the class is to provide a hands-on experience configuring and troubleshooting of the 8700 Magnetic metering system composed of the Model 8712 and 8732 Transmitters and the 8705 Flanged and 8711 Wafer Sensors. The students will learn the operation and capabilities of the Local Operator interface & HC475 and how to use these tools to perform configuration. Common issues encountered and troubleshooting techniques will also be covered.

#### Topics

- Magnetic Flowmeter System
- Smart vs. Analog Transmitters
- Flow Tube Selection
- Configuring Using LOI and AMS Device Manager
- Local Operator Interface Functions
- Positive Zero Return
- Auxiliary Functions and Special Units
- Signal Conditioning
- System Troubleshooting and Maintenance
- Bench Testing/Digital Trims
- Process Noise and Grounding Diagnostics
- Meter Verification Diagnostics

#### Audience

This course is intended as a refresher course for anyone that is involved with properly configuring and troubleshooting a Rosemount 8700 Series Smart Magnetic Flowmeter. Typical job functions include; maintenance technicians, instrument technicians and instrumentation engineers. This class is also intended to be taught as two, 1/2-day repeat sessions to accommodate customers who need to train their entire department but must also maintain the operation of their plant by scheduling their employees between an AM/PM sessions.

#### Prerequisites

Some prior experience working with Rosemount Magnetic Flowmeters meters is recommended. However, students with no past experience can also benefit. For all attendees, it is assumed they have a basic understanding of the fundamentals of flow measurement, electricity, analog & frequency signal processing.

### Rosemount 8800 Series Smart Vortex Flowmeter - Introduction - 2339SV CEUs – 0.4

#### Overview

This 1/2-day field class is a condensed version of the 2341 course briefly reviewing the theory of operation, meter components and installation. The focus of the class is to provide a hands-on experience configuring and troubleshooting of the 8800 Vortex metering system. The students will learn the operation and capabilities of the Local Operator interface & HC475 and how to use these tools to perform configuration. Common issues encountered and troubleshooting techniques will also be covered.

#### Topics

- Explain the Differences and Capabilities of the Rosemount 8800 Series Vortex Flowmeters
- Explain the von Karman Effect and Principles of Operation of Vortex Flowmeters
- Identify Vortex Parts and Explain Functionality
- Configure and Test Transmitters using the AMS Device Manager
- Properly Install and Troubleshoot the Rosemount 8800 Series Vortex Flowmeter System

#### Audience

This class is intended as a refresher course for anyone that is involved with properly configuring and troubleshooting a Rosemount 8800 Series Smart Vortex Flowmeter. Typical job functions include; maintenance technicians, instrument technicians and instrumentation engineers. This class is also intended to be taught as two, 1/2 day repeat sessions to accommodate customers who need to train their entire department but must also maintain the operation of their plant by scheduling their employees between an AM/PM sessions.

#### Prerequisites

Some prior experience working with Micro Rosemount Vortex Flowmeters meters is recommended. However, students with no past experience can also benefit if their learning objectives are to get a basic introduction to operation, installation, configuration and troubleshooting. For all attendees, it is assumed they have a basic understanding of the fundamentals of flow measurement, electricity, analog & frequency signal processing.

### Micro Motion Coriolis, Rosemount 8700 Magnetic & 8800 Vortex Wireless – 2383 CEUs - 0.70

#### Overview

This 1-day course consists of a blend of lectures and hands-on exercises that cover a basic overview of wireless capabilities with a Micro Motion Coriolis, Rosemount 8700 Series Magnetic and 8800 Series Vortex meters. Based on customer need, the class can be taught for each of the individual products. The course provides a step by step process for the following: how to install and wire a 775 Smart Wireless THUM to each transmitter, how to configure the THUM, how to configure the 1420 Wireless Gateway to the THUM using AMS Device Manager and how to add and view the Micro Motion and Rosemount transmitters to the gateway.

#### Topics

- Explain the Fundamentals for how a Micro Motion Coriolis, Rosemount 8700 Series Magnetic & 8800 Series Vortex Flowmeters Work with a 1420 Wireless Gateway and 775 Smart THUM Adapter
- Install and Wire a 775 Smart THUM to Micro Motion and Rosemount Transmitters
- Connect to and Configure the Micro Motion and Rosemount Transmitters to work with a 1420 Wireless Gateway
- Configure a 775 Smart THUM and the Transmitters to Communicate on the Gateway using AMS Device Manager

#### Audience

This course is intended for anyone that is involved with installing, wiring, configuring and troubleshooting a Micro Motion Coriolis, Rosemount 8700 Magnetic & 8800 Vortex flowmeters with a 775 Wireless THUM. Typical job functions include; maintenance technicians, instrument technicians and instrumentation engineers.

#### Prerequisites

General understanding of the HART® protocol and operation and configuration of a Micro Motion Coriolis, Rosemount 8700 Magnetic and 8800 Vortex meters is assumed.



**Rosemount 8700 Series Smart Magnetic & 8800 Smart Vortex Flowmeters - Introduction – 2394**  
CEUs - 0.7

**Overview**

This 1-day course is an abbreviated version of the 2340 and 2341 courses for Rosemount 8700 Series Magnetic and 8800 Series Vortex meters. Typically, 2/3 of the course time is spent on Rosemount's 8800 Vortex flowmeter and 1/3 on Rosemount's 8700 Magnetic Flowmeter. Theory of operation, meter components and installation of each flowmeter are covered. The focus of the class is to provide a hands-on experience configuring and reviewing the most common troubleshooting issue and best practices for resolution.

**Topics**

- After attending the course the student will be able to do the following for both the Rosemount Magnetic and Vortex flowmeters:
- Briefly Explain the Fundamentals for How Each Flowmeter Works and the Function of the Key Components
- Have a Basic Understanding of the Installation Best Practices for Orienting, Mounting and Wiring the Sensor and Transmitter
- Perform a Basic Configuration of the Metering System for Various Applications
- Diagnose and Know How to Correct the Most Common Meter and Process Issues

**Audience**

This combined class is intended anyone that is involved with properly configuring and troubleshooting a Rosemount 8700 Smart Magnetic & 8800 Smart Vortex Flowmeters. Typical job functions include; maintenance technicians, instrument technicians and instrumentation engineers.

**Prerequisites**

This being a 1-Day class covering two flowmeters, some prior experience working with Rosemount's Magnetic and Vortex flowmeters is recommended. However students with no past experience can also benefit if their learning objectives are to get a basic introduction to operation, installation, configuration and troubleshooting. For all attendees, it is assumed they have a basic understanding of the fundamentals of flow measurement, electricity, analog & frequency signal processing.

**Micro Motion Coriolis & Rosemount 8700 Series Smart Magnetic Flowmeters – Introduction - 2384**  
CEUs - 0.7

**Overview**

This 1-day field class provides hands-on training on both the Coriolis and Magnetic Flowmeters. Typically, 2/3 of the course time is spent on Micro Motion's Coriolis meter and 1/3 on Rosemount's 8700 Magnetic Flowmeter. Theory of operation, meter components and installation of each flowmeter are covered. The focus of the class is to provide a hands-on experience configuring and troubleshooting best practices. Students will learn the Micro Motion Series 1000/2000 transmitters using one of these configuration tools; Prolink III, HC475, AMS Device Manager or Series 3000 display interface devices. Public field classes typically use Prolink III for configuring the Micro Motion transmitters and the HC475 will be used for the Rosemount 8700 Magnetic flowmeter. Customers can choose which configuration device is used for classes held at their site.

**Topics**

- After attending the course, the student will be able to do the following for both Micro Motion's Coriolis and Rosemount 8700 Magnetic flowmeters:
- Briefly Explain the Fundamentals for How Each Flowmeter Works and the Function of the Key Components
  - Basic Understanding of the Installation Best Practices for Orienting, Mounting and Wiring the Sensor and Transmitter
  - Perform a Basic Configuration of the Metering System for Various Applications
  - Diagnose and Know How to Correct the Most Common Meter and Process Issues

**Audience**

This combined class is intended anyone that is involved with properly configuring and troubleshooting a Micro Motion flow and density meter and Rosemount 8700 Smart Magnetic Flowmeters. Typical job functions include; maintenance technicians, instrument technicians and instrumentation engineers.

**Prerequisites**

Some prior experience working with Micro Motion Coriolis & Rosemount 8700 Magnetic flowmeters is recommended. However, students with no past experience can also benefit. A basic understanding of the fundamentals of flow measurement.

**Micro Motion Coriolis & Rosemount 8800 Series Smart Vortex Flowmeters – Introduction - 2387**  
CEUs - 0.7

**Overview**

This 1-day field class provides hands-on training on both Coriolis and Vortex Flowmeters. Typically, 2/3 of the course time is spent on Micro Motion's Coriolis meter and 1/3 on Rosemount's 8800 Vortex Flowmeter. Theory of operation, meter components and installation of each flowmeter are covered. The focus of the class is to provide a hands-on experience configuring and troubleshooting best practices. Students will learn the Micro Motion Series 1000/2000 transmitters using one of these configuration tools; Prolink III, HC475, AMS Device Manager or Series 3000 display interface devices. Public field classes typically use Prolink III for configuring the Micro Motion transmitters and the HC475 will be used for the Rosemount 8800 Vortex flowmeter. Customers can choose which configuration device is used for classes held at their site.

**Topics**

- Students will be able to do the following for both Micro Motion's Coriolis and Rosemount 8800 Vortex flowmeters:
- Briefly Explain the Fundamentals for How Each Flowmeter Works and the Function of the Key Components
  - Have a Basic Understanding of the Installation Best Practices for Orienting, Mounting and Wiring the Sensor and Transmitter
  - Perform a Basic Configuration of the Metering System for Various Applications
  - Diagnose and Know how to Correct the Most Common Meter and Process Issues
  - Configure the Metering System to Measure Available Process Variables from the Device for Their Application
  - Learn a Step by Step Process to Perform Basic Troubleshooting of the Most Common Meter and Process Issues

**Audience**

This combined class is intended anyone that is involved with properly configuring and troubleshooting a Micro Motion flow and density meter and Rosemount 8800 Micro Motion - Coriolis & Rosemount 8800 Vortex Flowmeters – 2387

**Prerequisites**

Some prior experience with Micro Motion Coriolis & Rosemount 8800 Vortex flowmeters. A basic understanding of the fundamentals of flow measurement, electricity, analog and frequency signal processing.

**Rosemount Tank Gauging Systems-  
RTG101  
CEUs - 3.5****Overview**

This 5-day Tank Gauging Technical Product Training focuses on the 5900S system, our Wireless Tank Gauging System, a little about Rex and Pro, as well as other field equipment relevant for the Rosemount Tank Gauging system. The training covers installation, configuration and troubleshooting of our products, as well as general TankMaster functions. Students who complete this course will:

- correctly perform installation and setup procedures
- properly configure Tank Gauging System
- plan a Wireless installation
- perform basic troubleshooting

**Topics**

- System Overview
- Perform basic troubleshooting
- 2410 TankHub
- 5900 Gauges
- Rosemount 2240S
- Rosemount 2230 Display
- 5300/5400 Gauges
- Field Communication
- Electrical and Mechanical Installation
- System Configuration
- LPG/LNG
- Wireless
- AMS Wireless Snap-On
- Gateway
- Emulation
- SIL
- Troubleshooting

**Audience**

This course is customized for service, project, and sales engineers. The course includes both practical and theoretical training

**Prerequisites**

This course is suitable for service, project, and sales engineers, and is a good start for new employees and customers.

**Rosemount TankMaster Software –  
Introduction - RTG102  
CEUs – 2.5****Overview**

This 4-day TankMaster Training covers more detailed information about TankMaster functions.

Students who complete this course will be able to:

- Perform System Configuration
- Configure Host Communication
- Properly use Redundancy
- Use Batch Handling
- Program Basic Custom Views
- Perform Basic Troubleshooting

**Topics**

- System Overview
- Volume Calculations
- WinOpi Tools Menu
- Host Communication and OPC
- TankMaster Batch
- Custom Views and Translation
- Network Basics
- TankMaster to Enraf
- Redundancy
- Administrator Program Backup & Restore
- TankMaster Hybrid & HTG
- Troubleshooting

**Audience**

This course is suitable for anyone who works with TankMaster, including customers who is using WinOpi as the operator interface. The course includes both practical and theoretical training.

**Prerequisites**

It is required that you previously attended the RTG101 Technical Product Training course or have very good knowledge of the Rosemount Tank Gauging System.

**Rosemount MLT Process Gas Analyzers– 2110****Overview**

This 3-day course is a classroom training where students learn principles and practical operation of MLT analyzers. Through hands-on training, the student will learn on how to install, maintain, and troubleshoot the MLT analyzer.

Using MLT Analyzer demo units students will:

- Understand the Photometric measurement principles such as the theory of Infrared and Ultraviolet Spectrometry, Paramagnetic and Thermal Conductivity
- Learn the signal processing of the electronic boards.
- Learn the test procedure for troubleshooting and diagnostics

**Topics**

- Introduction to the function of Physical parts
- Function of Electronic boards
- Test points and procedure
- Mechanical Assembly / Disassembly
- Programming of software parameters
- Calibration setup manual (Auto calibration when available)
- Analog outputs, and Digital Inputs / Outputs
- Save / Load configuration functionality
- Spare parts

**Prerequisites**

Basic Knowledge of PGA Analysers would be helpful

**Rosemount X-Stream Gas Analyzer for Continuous Emissions Monitoring Systems – 2157****Overview**

This 3-day course covers basic fundamentals and the theory of operation, installation, calibration and maintenance of Continuous Emissions Monitoring Systems (CEMS).

**Topics**

- Environmental Requirement
- Process Applications
- Theory of Operation
- Sample System Instrument
  - Installation and Troubleshooting
  - Hardware and Maintenance

**Audience**

This course is for instrument technicians responsible for the maintenance of continuous emissions monitoring systems.

**Rosemount Oxygen Flue Gas & 6888A Analyzers– 2153 CEUs – 0.7****Overview**

This 1-day course covers combustion measurement principles and the theory of operation of oxygen analyzers. The class will discuss the installation, operation, calibration and maintenance of the Rosemount 6888A Oxygen Analyzer.

**Topics**

- Combustion Requirements
- Methods of Oxygen Analysis
- Typical Uses of Oxygen Analysis
- Combustion Efficiency
- Zirconia (ZrO<sub>2</sub>) Oxygen Analysis
- Theory of Operation
- Oxygen Analyzer
  - Installation
  - Hardware
  - Maintenance
  - Troubleshooting
- Hart Communicatons

**Rosemount X-Stream Process Gas Analyzers – 2170****Overview**

This 3-day course is a classroom training where students learn principles and practical operation of X2 analyzers. Through hands-on training, the student will learn on how to install, maintain, and troubleshoot the X2 analyzer.

Using X2 Analyzer demo units students will:

- Understand the Photometric measurement principles such as the theory of Infrared and Ultraviolet Spectrometry, Paramagnetic and Thermal Conductivity
- Learn the signal processing of the electronic boards.
- Learn the test procedure for troubleshooting and diagnostics

**Topics**

- Introduction to the function of Physical parts
- Function of Electronic boards
- Test points and procedure
- Mechanical Assembly / Disassembly
- Programming of software parameters
- Calibration setup manual (Auto calibration when available)
- Analog outputs, and Digital Inputs / Outputs and Modbus setup
- Save / Load configuration functionality
- Spare parts
- Troubleshooting Procedure

**Prerequisites**

Basic Knowledge of PGA Analysers would be helpful

**500 Gas Chromatograph - Introduction - R4100  
CEUs - 2.1****Overview**

This 3-day course gives students a basic understanding of how the Rosemount Analytical 500 and 700 gas chromatographs (formerly Danalyzer GCs) work, emphasizing chromatograph fundamentals and basic theory.

**Topics**

- Reviewing Basic Chromatography Principles
- Understanding Chemistry, Flow Configuration, and Gas Systems
- Understanding Basic Sample Systems
- Working with Chromatograph Hardware
- Setting Timed Events, Retention Times, and Response Factors
- Understanding Data Calculations
- Identifying Problems Using Chromatograms

**Rosemount 700XA & 1500XA Gas Chromatographs - Introduction - R4105  
CEUs - 2.1****Overview**

This 3-day course gives students basic understanding of how Rosemount Analytical gas chromatographs 700XA & 1500XA (formerly Danalyzer GCs) work, emphasizing chromatograph fundamentals and basic theory.

**Topics**

- Reviewing Chromatography Principles
- Understanding Chemistry, Flow Configuration, and Gas Systems
- Reviewing Sample Systems
- Working with Chromatograph Hdw
- Setting Timed Events, Retention Times, and Response Factors
- Understanding Data Calculations
- Reading Chromatograms
- Calibrating a Gas Chromatograph

**Rosemount 500 Process Gas Chromatograph - Intermediate- R4210  
CEUs - 2.8****Overview**

This 5-day course is appropriate for those who have either worked with a Gas Chromatograph for at least six months or completed the Introductory Gas Chromatograph course. It prepares participants to operate and repair a Model 500 Gas Chromatograph.

**Topics**

- Understanding Gas Chromatography and a Gas Chromatograph
- Using the Basic Chromatograph System in Process Gas Analysis
- Understanding Carrier and Calibration Gas Systems
- Installing and Operating MON Software
- Applying Chromatograph Integration Techniques and Post-Analysis Calculations
- Using the Chromatograph to Identify Problems
- Setting Timed Events, Retention Times, and Response Factors
- Starting Up a Gas Chromatograph
- Understanding Sample Handling Systems
- Verifying Proper Operation of a Gas Chromatograph
- Troubleshooting the 2350A Controller
- Configuring the 2350A Controller User Directory Outputs
- Conducting Preventative Maintenance
- Communicating to Other Devices
- Reviewing Spare Parts Recommendations

**Prerequisites**

Students that have at least 6 months experience with Emerson GC's, just purchased an Emerson GC or are seeking a refresher course after having worked on their Emerson GC benefit most from this course. Candidates from non-technical backgrounds should consider taking R4100 Introduction to GC's (for Model 500, 700 or 1000)

Classes typically start at 1pm CST on Monday and end at 12pm CST on Friday to accommodate travel

**Rosemount 370XA Gas Chromatograph – Introduction – E4070****Overview**

Online introduction to Rosemount's 370XA Gas Chromatograph.

**Topics**

- Reviewing 370XA features
- Installation
- Calibration
- Introducing the Maintainable Module™
- Reading Chromatograms

**Rosemount 370XA Gas Chromatograph - Intermediate - R4170  
CEUs – 2.1****Overview**

This 3-day training is a level 1 course and includes theory, operations and maintenance practices for the Rosemount Analytical 370XA Gas Chromatograph (formerly Danalyzer GC). Module overview hardware and software overview as well as basic troubleshooting skills.

**Topics**

- Chromatographic Theory
- Detector Theory
- Understanding Chromatograms
- Startup Procedures
- Natural Gas Sample Handling
- Using 370XA Software Assistants
- Cal-Saver™
- Running Auto Valve Timing
- Module Initializations
- Calibrations, Validation & Routine Maintenance (Valve Rebuilding)
- Troubleshooting the module
- 370XA Hardware
- MON2020 Software

**Prerequisite**

E4070 Introduction to the Model 370XA.

**Rosemount 700XA & 1500XA Process Gas Chromatograph - Intermediate - R4213/R4214  
CEUs – 2.8****Overview**

This 5-day course is appropriate for those who have either worked with a GC for at least six months or completed the introductory gas chromatograph course. It prepares participants to operate and repair a Rosemount Analytical 700XA & 1500XA Gas Chromatograph.

**Topics**

- Understanding Gas Chromatography and Gas Chromatographs
- Using the Basic Chromatograph System in Process Gas Analysis
- Understanding Carrier and Calibration Gas Systems
- Installing and Operating MON Software
- Applying Chromatograph Integration Techniques and Post-Analysis Calculations
- Using the Chromatograph to Identify Problems
- Setting Timed Events, Retention Times, and Response Factors
- Starting Up a Gas Chromatograph
- Understanding Sample Handling Systems
- Verifying Proper Operation of the Gas Chromatograph
- Conducting Preventative Maintenance
- Communicating to Other Devices
- Reviewing Spare Parts Recommendations

**Audience**

This course is best suited for students working in a technical environment.

**Prerequisites**

Students that have at least 6 months experience with Emerson GC's, just purchased an Emerson GC or are seeking a refresher course after having worked on their Emerson GC benefit most from this course. Candidates from non-technical backgrounds should consider taking R4105 Introduction to GC's (for 700XA/1500XA).



### Rosemount Gas Chromatograph Flame Photometric Detector Module - Operation & Maintenance - R4215 CEUs – 2.8

#### Overview

The 5-day course covers the theoretical and practical aspects of the flame Photometric Module [FPD] used with the model 500, 700 and 700XA. It does not cover any aspect of the theory of the model 500, 700 or 700XA neither does it cover the menus and use of MON2000/ MON2020. The course concentrates on practical work. The course is aimed at those who will be carrying out maintenance on the FPD module.

#### Topics

- Sulphur
- FPD Theory and Maintenance
- Applications
- Dismantling and Rebuilding a Flame Cell Replacing all the "O" Rings
- Removing/Installing the Flame Cell and Photomultiplier into the FPD Module
- Setting Up the Hydrogen/Air Ratio to Achieve Continuous Combustion
- Adjusting the Entry of the sample into the Flame Cell
- Setting Up the Flame Out Circuit
- Adjusting the Amplifier to Optimize Peak Amplitude
- FPD Chromatograms
- Routine Maintenance
- Fault Finding

#### Prerequisites

Students attending this course must have completed either of these Operations & Maintenance courses: R4210, R4212, or R4213/R4214.

### Rosemount 500 Process Gas Chromatograph – Advanced - R4311 CEUs – 2.8

#### Overview

This 5-day course is most valuable to those with three years of chromatography experience, or those who have completed the introductory 'Operation and Maintenance of Gas Chromatographs' course. Participants will develop an advanced understanding of gas chromatograph operation, troubleshooting, and maintenance. Training becomes customized when students present application information. Given that data, the experienced instructor will look closely at specific applications and offer participants insight.

#### Topics

- Understanding Chromatograph Flow Configurations
- Overhauling Valves
- Reviewing Thermal Conductivity, Flame Ionization, and Flame Photometric Detectors
- Understanding Sample/Carrier/Calibration Gas Systems
- Working with and troubleshooting the Rosemount Analytical 2350A Controller
- Installing and Using MON Software for Integration and Calibration
- Setting Timed Events, Retention Times, and Response Factor Calculations
- Understanding Startup Procedures
- Setting Valve Timing and Flows with Different Flow Configurations
- Checking for Proper Separation and Analyzing Gas Chromatographs
- Verifying Proper Operation of the Gas Chromatograph
- Troubleshooting the Chromatograph and 2350A Controller
- Configuring Reporting Details and Control Outputs
- Conducting Preventative Maintenance
- Communicating to Other Devices
- Reviewing Spare Parts Recommendations

#### Prerequisites

Students attending this course must have completed either of these Operations & Maintenance courses: R4210, R4212, or have 3 years of advanced chromatography experience.

### Rosemount 700XA & 1500XA Gas Chromatographs (GC) - Advanced - R4315/R4316 CEUs - 3.5

#### Overview

This 5-day course equips students with a full understanding of many advanced techniques used in process gas chromatography. An experienced instructor and focused material enable students to troubleshoot a variety of field issues for the Rosemount Analytical 700XA & 1500XAGC.

#### Topics

- Setting Valve Timing
- Hardware Troubleshooting
- Mixture Adjustments for FID
- Mixture Adjustment for FPD
- Verifying proper operation of the Gas Chromatograph
- Overview of Model 1500XA
- Liquid Sample Injection
- Review of Sample System Techniques
- Calibration and Accuracy Checks
- Recovery of GC After Analysis Interruption
- GC Start-up After Overhaul
- Communicating to Other Devices
- Understanding flow settings for various flow configurations
- Understanding when to overhaul valves

#### Prerequisite

Students attending this course must have completed either of Operations & Maintenance course R4213/R4214 or have 3 years of advanced chromatography experience.

### Rosemount Liquid Analysis pH, Conductivity & ORP Theory – 2200 CEUs - 0.7

#### Overview

This 1-day course provides a solid theoretical background in pH, Conductivity, and ORP measurements. Students who complete this course will be able to:

- Understand how each measurement is made
- Recognize installation/application problems
- Configure and calibrate instruments
- Implement a maintenance program
- Troubleshoot problems using diagnostics

#### Topics

- What is pH/Conductivity/ORP
- How pH/Conductivity/ORP Measurements are Made
- Physical Process Properties and How They Effect On-Line Measurements
- Proper Calibration Techniques
- Cleaning and Maintenance of a Sensor
- Choosing Correct Sensor for Any Process
- How to Decipher Diagnostics Readouts
- pH/Conductivity Sensor Overview
- pH/Conductivity/ORP Analyzer Overview

### Rosemount Liquid Analysis Chlorine, Dissolved Oxygen & Ozone Amperometric Measurement Theory– 2201 CEUs - 0.7

#### Overview

This 1-day course provides insight into the complicated amperometric measurements of chlorine, dissolved oxygen and ozone. Students will learn the concepts of how amperometric sensors work and how to calibrate each type of measurement. Students who complete this course will be able to:

- Understand the theory behind how amperometric sensors work and how to calibrate each type of measurement
- Differentiate the various species of chlorine
- Implement a proper maintenance program
- Use diagnostics to troubleshoot problems

#### Topics

- Amperometric Measurement Theory:
- Chlorine/Dissolved Oxygen/Ozone
- Calibration Procedures for Each Measurement
- Maintenance & Troubleshooting Tips

### Rosemount Liquid Analysis Measurement Theory – 2205 CEUs - 0.7

#### Overview

This 7-hour class is fully customized to cover the specific measurements that the customer requests. A certified trainer will cover up to 4 subjects in one day. The 4 subjects may be measurement or product related. The list of measurements that can be bundled into a tailored made training course are pH, ORP, contacting conductivity, toroidal conductivity, turbidity, chlorine, dissolved oxygen, and ozone. Each measurement theory has its own duration which can be modified to fit the customers' time frame needs. Select an analyzer (course 2204) or transmitter (course 2202) to accompany the measurement theories for a well-rounded class.

#### Topics

- Installation and Application Problems
- Configuration of Outputs / Alarms (If applicable)
- Use Diagnostic Features (If Applicable)
- Sensor Calibration & Maintenance
- Troubleshooting

### Rosemount 1056 Dual Input Analyzer-e2601 CEUs - 0.10



#### Overview

Introduction to the 1056 Dual Input Analyzer, including overview of functions, mechanical and electronic installation, adding sensor boards and wiring sensors, and using the interface.

Basic installation, configuration and calibration training in the 1056 Analyzer.

### Rosemount Liquid Analysis pH Theory – Introduction - e2602 CEUs - 0.1



#### Overview

Entry level training in pH Theory, including explanation of pH measurement, industries utilizing measurement, types of pH measurement, science of determining pH, and examination of a pH detector and sensor.

Explain pH to learner to impart a solid, working knowledge of pH and how it is measured and why, in industry, and understanding of pH scale, and pH sensors.

# Educational Services

Maximize Your Investment with Well-Trained Personnel



203

## Maximize Your Investment!

### I&E Measurement Instrument Technician Curriculum Path

#### Self-Guided Primers

- E2300

#### Core Competencies

- 2326 Measurement Products I
- 2327 Measurement Products II
- 2333 Measurement Products III

#### Additional Competencies

- 7021 AMS Device Manager with Rosemount HART

#### I&E Technician Job Competencies

- Install, Configure, and Test Measurement Instruments
- Maintain & Troubleshoot Measurement Instruments
- Connect to HART Devices
- Calibrate & Commission devices and instrumentation

Your maintenance technicians instrument knowledge and skills can affect your plants performance, up-time and maintenance costs and ultimately your bottom line.

Emerson Educational services can boost your personnel skills, performance and reinforce job competencies.

Emerson I&E Technician Curriculum Path provides focused, in-depth skills-based training for proper installation, configuration, testing, calibrating, maintaining and troubleshooting your Measurement Instruments.

[Education@Emerson.com](mailto:Education@Emerson.com)

Or more training options see us at:

[www.emerson.com/education](http://www.emerson.com/education)

I&E Measurement Instrumentation Engineer Curriculum Path

# Educational Services

Maximize Your Investment with Well-Trained Personnel



204

## Maximize Your Investment!

### Self-Guided Primers

- E2300

### Core Competencies

- 2326 Measurement Products I
- 2327 Measurement Products II
- 2333 Measurement Products III
- 2370 Fieldbus Instruments
- 2375 Wireless Plant Network
- 7021 AMS Device Manager with Rosemount HART

### I&E Engineer Job Competencies

- Install, Configure, and Test Measurement Instruments
- Maintain & Troubleshoot Measurement Instruments
- Connect to HART, Wireless and Fieldbus Devices
- Calibrate & Commission devices and instrumentation
- Calibration Management
- Instrument Reliability
- Instrument Selection

Your maintenance engineer instrument knowledge and skills can affect your plants performance, up-time and maintenance costs and ultimately your bottom line.

Emerson Educational services can boost your personnel skills, performance and reinforce job competencies.

Emerson I&E Engineer Curriculum Path provides focused, in-depth skills based training for proper installation, configuration, testing, calibrating, maintaining and troubleshooting your Measurement Instruments.

[Education@Emerson.com](mailto:Education@Emerson.com)

Or more training options see us at:

[www.emerson.com/education](http://www.emerson.com/education)

# Educational Services

Maximize Your Investment with Well-Trained Personnel



205

## Maximize Your Investment!

### Control System Engineer Curriculum Path

#### Self-Guided Primers

- e9025, Control Loop Foundation

#### Core Competencies

- 7009, DeltaV Implementation I
- 7016, DeltaV Batch Implementation

#### Additional Competencies

- 7076, DeltaV PMO Configuration Standard
- 7201, DeltaV Advanced
- 7202, DeltaV Model Predictive Control
- 7017, DeltaV Implementations II
- 7025, DeltaV Advanced Graphics
- 7018, DeltaV Hardware & Troubleshooting
- 7037, Communication Interfaces with the DeltaV System
- 7027, DeltaV Systems Administration Window 7/Server 2008
- 7305, DeltaV SIS Implementation
- 7020, AMS Device manager or 7039, AMS Device Manager with DeltaV
- 7032, FieldBus System and Devices

#### Job Competencies

- Support DeltaV Automation Control System performance
- Maintain, troubleshoot, and enhance configuration, application and operation of Basic Process Control System and Safety Instrumented System (SIS)
- Identify, plan, and implement process control Improvement projects
- Productivity of Operations Personnel
- Alarm Rationalization and Management
- Construct and support external communication links
- Overall Risk Management of DeltaV Automation Control System

Your control system engineers' process and technical knowledge and skills can directly impact your facility's bottom line. Emerson Educational Services can dramatically boost your personnel skills and performance and reinforce job competencies.

Emerson Process Control System Engineers' Curriculum Path provides focused, in-depth, objective-based training on product-specific procedures for proper configuration and maintenance of your DeltaV distributed control system. Your control systems engineers' get practical application skills through dedicated classroom facilities and hardware.

[Education@emerson.com](mailto:Education@emerson.com)

Or more training options see us at:

[www.emerson.com/education](http://www.emerson.com/education)



# Educational Services

Maximize Your Investment with Well-Trained Personnel



206

## Maximize Your Investment!

### Continuous Control Operators Curriculum Path

#### Self-Guided Primers

- e9025, Control Loop Foundation

#### Core Competencies

- 7012, DeltaV Operator Interface for Continuous Control
- DeltaV Essential Operator Training Solution

#### Additional Competencies

- 7009, DeltaV Implementation I

#### Job Competencies

- Ensure Safe and Effective Operation
- Communicate production status
- Work turnaround projects
- Management of Change process of standard operating procedures
- Recognize and effectively respond to unusual process issues
- Troubleshoot difficult production issues
- Suggest Production improvements
- Alarm Management
- Tune loops

Your operators' process knowledge and skill levels affect how your process is run, which can directly impact your facility's bottom line.

Emerson Education Services can dramatically boost your personnel skills and performance and reinforce job competencies.

Emerson Operator Curriculum Path provides focused, in-depth, objective-based training on product-specific procedures for proper operation and maintenance of your DeltaV distributed control system. Your operators get practical application skills through dedicated classroom facilities and hardware. Train your operator for peak performance and process profitability.

[Education@emerson.com](mailto:Education@emerson.com)

Or more training options see us at

[www.emerson.com](http://www.emerson.com)

# Educational Services

Maximize Your Investment!



207

## Maximize Your Investment!

### I&E Maintenance Technical Curriculum Path

#### Self-Guided Primers

- e9025, Control Loop Foundation

#### Core Competencies

- 7018, DeltaV Hardware & Troubleshooting
- 7020, AMS Device Manager or 7039, AMS Device Manager with DeltaV

#### Additional Competencies

- 7009, DeltaV Implementation I
- 7016 DeltaV Batch Implementation
- 7030 Fieldbus Devices
- 5590, Power Quality and Grounding
- 7303/4, DeltaV SIS Maintenance
- 7037, Communication Bus Interfaces with DeltaV Systems

#### Job Competencies

- Maintain, trouble shoot, and make configuration changes to Basic Process Control System and Safety Instrumented Systems (SIS)
- Connect to HART® & Fieldbus devices
- Calibrate and commission devices, instruments and valves
- Proactively monitor devices for alerts, troubleshoot device problems & faulty assets

Effectiveness of Maintenance Reliability Program

Your maintenance technicians' process knowledge and skills can affect your facility's performance, up-time, and maintenance cost-and ultimately your bottom line.

Emerson Educational Services can dramatically boost your personnel skills and performance and reinforce job competencies.

Emerson I&E maintenance Technician Curriculum Path provides focused, in depth, objective-based training on product-specific procedures for proper maintenance of your DeltaV distributed control system. Your maintenance technicians get practical applications skills through dedicated classroom facilities and hardware.

[Education@emerson.com](mailto:Education@emerson.com)

Or more training options see us at:

[www.emerson.com/education](http://www.emerson.com/education)

# Educational Services

Maximize Your Investment with Well-Trained Personnel



208

## Maximize Your Investment!

### Batch Operators Curriculum Path

#### Self-Guided Primers

- e9025, Control Loop Foundation

#### Core Competencies

- 7014, DeltaV Operator Interface for Batch
- DeltaV Essential Operator Training Solution

#### Additional Competencies

- 7009, DeltaV Implementation I
- 7016 DeltaV Batch Implementation

#### Job Competencies

- Safely operate batches from start to finish
- Monitor batch for actionable information to keep batch within specification
- Perform manual batch tasks
- Update, review and report operator log book
- Manage sample collection with LIMS
- Provide production status during shift, anomalies, equipment, etc.

Your batch operators' process knowledge and skills levels affect how your process is run, which can directly impact your facility's bottom line.

Emerson Educational Services can dramatically boost your personnel skills and performance and reinforce job competencies.

Emerson Batch Operator Curriculum Path provides focused, in depth, objective-based training on product-specific procedures for proper operation and maintenance of your DeltaV distributed control system. Your batch operators get practical application skills through dedicated classroom facilities and hardware.

[Education@emerson.com](mailto:Education@emerson.com)

Or more training options see us at:

[www.emerson.com/education](http://www.emerson.com/education)



**Final Control**

**Plant Management & Engineering Learning Paths**

	Plant Management					Plant Control & Engineering				
	Plant Manager	Production Manager	Engineering Manager	Reliability Manager	Operator	Control System Engineer	Control System Administrator	E&I Engineer	Engineer	Process Engineer
Control Valve Engineering I	A	A	A	A		A			C	C
Control Valve Engineering II									C	A
Valve Technician I	A	A	A	A	A		A			A
FlowScanner Data Acquisition & Interpretation									A	
Advanced FlowScanner Diagnostic Interpretation									A	
Valve Technician II									A	
Instrument Technician						A	A			
FIELDVUE™ Digital Valve Controller Setup & Diagnostics using 475 Field Communicator & ValveLink™			A	A	A				A	A
ValveLink Software for Diagnostics of FIELDVUE – Digital Valve Controller									A	A
FOUNDATION™ fieldbus FIELDVUE Digital Valve Controller			A	C	A				A	A
Introduction to Fisher™ Control Valves	P	P	P	P	P	P	P	P	P	P

P – Primer | C – Core Competency | A – Additional Competency

[Education@emerson.com](mailto:Education@emerson.com)  
 Or more training options see us at:  
[www.emerson.com/education](http://www.emerson.com/education)





**Final Control**

**Plant Maintenance & IT Learning Paths**

	Instrument Technician	Vibration Analyst	Rotating Equipment Mechanic	Reliability Data Collector	Electrician	Lubrication Specialist	IT Administrator	Instrumentation Engineer	Unit Maintenance Electrician	Mechanic
Control Valve Engineering I								C		
Control Valve Engineering II										
Valve Technician I	C				A			A	C	C
FlowScanner Data Acquisition & Interpretation	C			C					A	A
Advanced FlowScanner Diagnostic Interpretation	A			C						A
Valve Technician II	C								A	C
Instrument Technician	C			C				C	A	
FIELDVUE™ Digital Valve Controller Setup & Diagnostics using 475 Field Communicator & ValveLink™	A			C				A		A
ValveLink Software for Diagnostics of FIELDVUE – Digital Valve Controller	A			C				A		
FOUNDATION™ fieldbus FIELDVUE Digital Valve Controller	A			A	A			A	A	A
Introduction to Fisher™ Control Valves	P	P	P	P	P	P	P	P	P	P

P – Primer | C – Core Competency | A – Additional Competency

[Education@emerson.com](mailto:Education@emerson.com)  
 Or more training options see us at:  
[www.emerson.com/education](http://www.emerson.com/education)





# Educational Services

Maximize Your Investment with Well-Trained Personnel



## 211

## Flow Metering Plant Maintenance Learning Paths

	Maintenance Manager	Maintenance Supervisor	Maintenance Technician	Instrument Technician
Basic Instrumentation (4-5)	X	X	X	
Flow Measurement (4-5)	X	X	X	X
Flow Measurement: Sizing and Selection (3)				
MMI Coriolis Technician (2)		X	X	X
MMI Coriolis Advanced (2)			O	X
MMI Coriolis Bi-annual Refresher (1)			O	X
Qualified Technician MMI Coriolis (4-5)				
Bi-annual Requalification MMI Coriolis (2)				
RF Vortex Technician (1)		X	X	X
RF Vortex Advanced (1)			O	X
RF Vortex Bi-annual Refresher (0.5)			O	X
Qualified Technician RF Vortex (3)				
Bi-annual Requalification RF Vortex (0.5)				
RF Magmeter Technician (1)		X	X	X
RF Magmeter Advanced (1)			O	X
Bi-annual Requalification RF Vortex (0.5)			O	X
Qualified Technician RF Magmeter (2)				
Bi-annual Requalification RF Magmeter (0.5)				
Density Measurement (2)		X	X	X
Viscosity Measurement (2)		O	O	X
D4230 Gas Ultrasonic Flowmeter (2)		X	X	X
D4280 Liquid Ultrasonic Flowmeter (2)		X	X	X
D4270 Compact Prover (2)		X	X	X
D4260 FloBoss™ S600 Flow Computer (2)		X	O	X
D4530 Metering Systems Introduction (2)		O	X	X
D4540 DanPac Metering Supervisory (2)		X	X	X
D4109 Qualitative Measurement and Properties of Natural Gases (2)		X	X	X
D4520 Hydrocarbon Gas Flow Measurement Systems (2)		O	X	X
D4510 Hydrocarbon Liquid Flow Measurement Systems (2)		O	X	X
MID Introduction (1)	O	O		

0 – Course Duration in days | X – Core Competency | O – Optional Additional Competency

Fundamentals of Instrumentation and Flow Measurement  
Flow Measurement Systems Related Courses

Product Courses for End Users and EPC's  
Application Courses

Product Courses for Service and Maintenance Providers

[Education@emerson.com](mailto:Education@emerson.com)  
Or more training options see us at:  
[www.emerson.com/education](http://www.emerson.com/education)



# Educational Services

Maximize Your Investment with Well-Trained Personnel



## 212

## Flow Metering Plant Engineering Learning Paths

	Plant Engineering Manager	Electrical & Instrument Engineer	Process Engineer	Control System Engineer	Metrologist
Basic Instrumentation (4-5)	X		X	X	X
Flow Measurement (4-5)	X		X	X	X
Flow Measurement: Sizing and Selection (3)		O	X		
MMI Coriolis Technician (2)		X	O		X
MMI Coriolis Advanced (2)		X		O	X
MMI Coriolis Bi-annual Refresher (1)		X			
Qualified Technician MMI Coriolis (4-5)					
Bi-annual Requalification MMI Coriolis (2)					
RF Vortex Technician (1)		X	O	O	
RF Vortex Advanced (1)		X			
RF Vortex Bi-annual Refresher (0.5)		X			
Qualified Technician RF Vortex (3)					
Bi-annual Requalification RF Vortex (0.5)					
RF Magmeter Technician (1)		X	O	O	
RF Magmeter Advanced (1)		X			
RF Vortex Bi-annual Refresher (0.5)		X			
Qualified Technician RF Magmeter (2)					
Bi-annual Requalification RF Magmeter (0.5)					
Density Measurement (2)		X		O	X
Viscosity Measurement (2)		X		O	
D4230 Gas Ultrasonic Flowmeter (2)		X	X		X
D4280 Liquid Ultrasonic Flowmeter (2)		X	X		X
D4270 Compact Prover (2)		X	O		X
D4260 FloBoss™ S600 Flow Computer (2)		X	X		X
D4530 Metering Systems Introduction (2)	O	O	O		
D4540 DanPac Metering Supervisory (2)		X	O	X	
D4109 Qualitative Measurement and Properties of Natural Gases (2)		X	X		O
D4520 Hydrocarbon Gas Flow Measurement Systems (2)		X	X	O	O
D4510 Hydrocarbon Liquid Flow Measurement Systems (2)		X	X	O	O
MID Introduction (1)	O	X	O		X

0 – Course Duration in days | X – Core Competency | O – Optional Additional Competency

Fundamentals of Instrumentation and Flow Measurement  
Flow Measurement Systems Related Courses

Product Courses for End Users and EPC's  
Application Courses

Product Courses for Service and Maintenance Providers

[Education@emerson.com](mailto:Education@emerson.com)  
Or more training options see us at:  
[www.emerson.com/education](http://www.emerson.com/education)



# Educational Services

Maximize Your Investment!



213

## Flow Metering

Project Management Team Paths

	Project Manager	Project Engineer	Instrument Engineer	Instrument Technician	Commission Lead
Basic Instrumentation (4-5)	X	X			X
Flow Measurement (4-5)	X	X	X	X	X
Flow Measurement: Sizing and Selection (3)	O	X	O		
MMI Coriolis Technician (2)		O	X	X	X
MMI Coriolis Advanced (2)			X	O	O
MMI Coriolis Bi-annual Refresher (1)					
Qualified Technician MMI Coriolis (4-5)					
Bi-annual Requalification MMI Coriolis (2)					
RF Vortex Technician (1)			X	X	X
RF Vortex Advanced (1)			X	O	O
RF Vortex Bi-annual Refresher (0.5)			X	O	O
Qualified Technician RF Vortex (3)					
Bi-annual Requalification RF Vortex (0.5)					
RF Magmeter Technician (1)			X	X	X
RF Magmeter Advanced (1)			X	O	O
Bi-annual Requalification RF Vortex (0.5)			X	O	O
Qualified Technician RF Magmeter (2)					
Bi-annual Requalification RF Magmeter (0.5)					
Density Measurement (2)			X	X	X
Viscosity Measurement (2)			X	X	O
D4230 Gas Ultrasonic Flowmeter (2)		O	X	X	X
D4280 Liquid Ultrasonic Flowmeter (2)		O	X	X	X
D4270 Compact Prover (2)		O	X	X	
D4260 FloBoss™ S600 Flow Computer (2)		O	X	X	O
D4530 Metering Systems Introduction (2)	X	X	X	X	X
D4540 DanPac Metering Supervisory (2)	O	O	X	X	X
D4109 Qualitative Measurement and Properties of Natural	O	O	X	X	X
D4520 Hydrocarbon Gas Flow Measurement Systems (2)	O	O	X	X	X
D4510 Hydrocarbon Liquid Flow Measurement Systems (2)	O	O	X	X	X
MID Introduction (1)	O	O	O		

0 – Course Duration in days | X – Core Competency | O – Optional Additional Competency

Fundamentals of Instrumentation and Flow Measurement  
 Courses for Service and Maintenance Providers  
 Flow Measurement Systems Related Courses

Product Courses for End Users and EPC's  
 Application Courses

Product

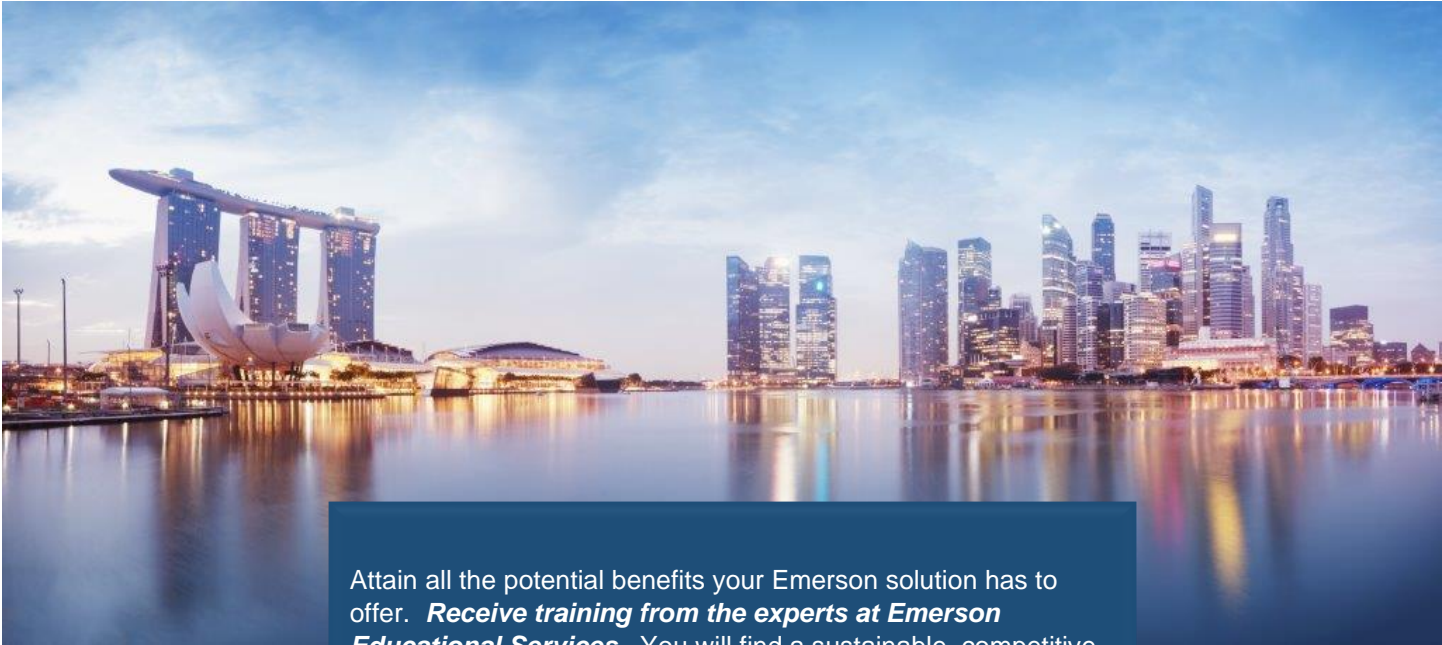

Attain all the potential benefits your Emerson solution has to offer. ***Receive training from the experts at Emerson Educational Services.*** You will find a sustainable, competitive edge through classes that help maximize your investment.

Contact us at **800-338-8158** or see us on our website at **[www.emerson.com/education](http://www.emerson.com/education)**

Emerson Automation Solutions  
205 South Center Street/PO Box 190  
Marshalltown, IA 50158-2823  
[www.emerson.com/education](http://www.emerson.com/education)

©Emerson Automation Solutions 2021. All rights reserved.

Emerson is a trademark of Emerson Electric Co. The MRG logo is a mark of one of Emerson Process Management family of companies. All other marks are property of their respective owners.

The contents of this publication are presented for informational purposes only, and while every effort has been made to ensure their accuracy, they are not to be construed as warranties or guarantees, express or implied, regarding the products or services described herein or their use or applicability. All sales are governed by our terms and conditions, which are available on request. We reserve the right to modify or improve the design or specification of such products at any time without notice.