



## TUNNELPASS LED™

TUNNEL AND UNDERPASS LUMINAIRE

  
**HOLOPHANE**®  
LEADER IN LIGHTING SOLUTIONS

**Acuity Brands.**

# LED LIGHTING IN TUNNELS

## WHY LED IN TUNNELS?



LED technology's growing popularity stems from its ability to significantly reduce energy consumption while offering more uniform illumination and a higher color rendering index than high pressure sodium lamps, which is the source traditionally used in tunnels – important benefits for tunnel environments.

LED luminaires also offer maintenance benefits, providing 20+ years or longer of operation to reduce costs and minimize lane closures. The latter permits the traffic flow volume to be maintained without interruption increasing commerce. Tunnel shutdown time is drastically reduced as there is no need to perform routine maintenance to replace failed high intensity discharge lamps and ballasts.

The luminaires are versatile enough to be ceiling or wall mounted, depending on the tunnel's geometry and height.



## A Tough Environment

Tunnels are challenging environments due to pollution from round-the-clock traffic and the corrosiveness associated with high levels of humidity, exhaust fumes and fluctuating temperatures. Luminaires in tunnels are also subjected to wind and reverberation of heavy vehicles passing by which cause vibration.

Lighting systems intended for this environment must include a robust mechanical design and materials capable of withstanding the challenges of a harsh environment over time.



## Safely Transitioning Drivers

The goal of any tunnel lighting system is to provide sufficient quality illumination to keep drivers who often travel at high rates of speed safe. Tunnels, however, present many unique challenges because lighting is required for both daytime and nighttime conditions.

To safely drive through a tunnel at posted highway speed during the day, a driver must be able to see into the tunnel. This is not possible if the tunnel is not properly lighted. Without daytime lighting, a tunnel entrance will appear as a black hole. Properly lighting a tunnel allows the driver's eye the time to adapt to the lower light levels inside the tunnel.

During daytime hours ambient light levels may exceed 10,000 foot-candles. The driver's vision will be adapted to this high level of light. Traveling at 65 miles per hour a vehicle is moving at 95 feet per second. In the time needed for visual adaption to occur a significant distance will be traversed, thus the need for

a high level of light at the tunnel entrance. This permits time for visual adaption while maintaining visibility into the tunnel. Once inside the tunnel, the lighting level may be gradually decreased and visibility will be maintained.

At night, the situation is reversed. Inside the tunnel the driver's vision is adapted to a level higher than outside the tunnel. Upon exiting the tunnel the driver's vision must have time to adapt to a lower level of light. The road beyond the exit portal should be lighted to at least one third the tunnel's lighting level.

# TUNNEL LIGHTING REQUIREMENTS & CRITERIA

## Daytime Tunnel Lighting Criteria Include Three Lighting Zones to Help Driver's Vision Adapt.

**Threshold zone** – This is the area beginning at the tunnel portal with a length equal to one Safe Sight Stopping Distance (SSSD) less the Adaptation Distance. Vehicles traveling at higher rates of speed will require longer threshold zones. A tunnel in which posted traffic speed is 70 miles per hour, for example, will require a longer threshold zone than a tunnel where the posted speed is 50 miles per hour.

**Transition zone** – This is the next area that allows a driver's vision to adapt to lower levels of light in incremental steps. The transition zone length and number of steps will depend upon the threshold luminance, daytime interior luminance and posted speed.

**Interior zone** – This is the area within the tunnel after the end of the transition zone where the driver's eye adaption is complete.

Nighttime tunnel lighting is recommended to be 2.5 cd/sq. m if the tunnel is divided. If the tunnel is undivided, the lighting level should be the same as the daytime interior level. Nighttime lighting is provided for the entire length of the tunnel. The road before and after the tunnel portal should be illuminated to at least 1/3 the nighttime level for a distance of 1 SSSD.

## Tunnel's Three Lighting Systems

Lighting systems for tunnels need to satisfy criteria for daytime, nighttime, and emergency situations. The current recommended practice for daytime and nighttime tunnel lighting is RP22-11 published by the Illuminating Engineering Society (IES). Tunnel lighting requirements are described in terms of luminance for road and wall surfaces. Requirements are determined based upon several factors:

- Approach scene, road grade of approach, and materials around approach
- Average annual daily traffic volume
- Posted speed limit
- Compass orientation of the tunnel's approach
- Direction of travel – one direction only (divided tunnel) or in two direction (undivided tunnel)

## Common Requirements for Daytime and Nighttime Lighting Systems

Both the daytime and nighttime lighting systems have common criteria regarding wall luminance and uniformity of light. The lower 6.6-ft portion of the walls above the roadway shoulder should have a maximum ratio of 2.5 between the average roadway luminance and the average wall luminance. Wall luminance is diffuse luminance as opposed to the roadway luminance which is calculated in accordance with the roadway luminance calculation procedure described in IES RP-8. Uniformity for tunnel lighting for the calculation areas within each zone should not exceed 2.0 average to minimum and 3.5 maximum to minimum ratios.

Emergency lighting is prescribed in the National Fire Protection Association (NFPA) publication 502. Emergency lighting is an aid to the egress of people and vehicles from the tunnel in the case of a power interruption. Requirements for emergency lighting are given in units of illuminance rather than luminance. Average levels are to be 1.0-fc with a minimum of 0.1 fc on walkway and roadway surfaces. The maximum to minimum ratio should be less than or equal to 40 to 1.

## HOLOPHANE: THE TUNNEL LIGHTING EXPERT

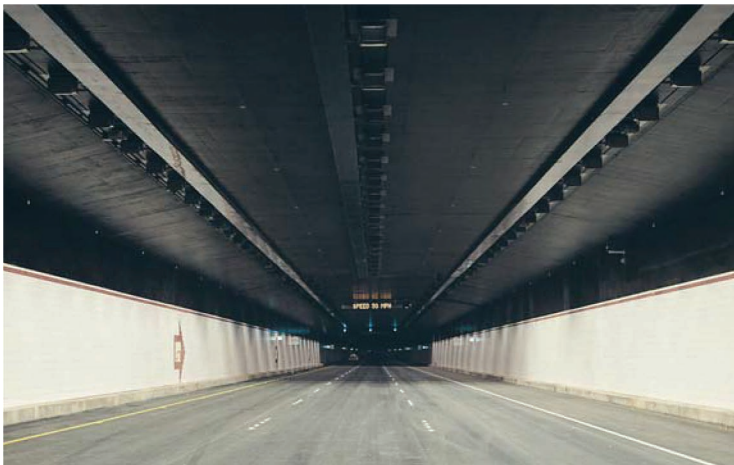

Holophane has been the leader in lighting solutions for more than a century and has supplied reliable, durable luminaires for tunnel applications for more than 25 years.

Three Holophane professionals helped form the Illuminating Engineering Society in 1906, and company engineers helped shape industry standards for tunnel lighting as members of the IES Tunnel Lighting Committee years later.

# APPLICATION EXPERTISE

## TUNNEL AND UNDERPASS LIGHTING APPLICATIONS

Today, Holophane experts offer application assistance in tunnel lighting design and provide full application support to see your project through from the beginning to completion. We are committed to help you meet your tunnel lighting goals, providing innovative products designed for performance and versatility – with minimal operating costs and long life.



# THE TUNNELPASS LED

## FEATURES AND BENEFITS

- ❑ Borosilicate prismatic glass lens for durability, permanence, and glare control
- ❑ Optimized thermal management system for maximum performance, long life, and reliability
- ❑ Robust design with IP66 rating, low copper 360 alloy castings, 3G vibration rating, anodized pre-treat and paint finish designed to meet a 9,000 hour salt fog rating
- ❑ Universal design that can be applied to either wall or ceiling mount with lumen packages to replace 100 watt through 400 watt HPS
- ❑ Dimming capability (0-10v) permits lumen output to be changed as required by control system
- ❑ Multiple lighting distributions to include ceiling counterbeam, long and narrow, and wall mount crossbeam
- ❑ Product ships complete with mounting brackets attached to aid in the installation of the product by one installer



## Lighting Distribution Options

Holophane TunnelPass LED luminaires offer three lighting distribution options to meet the lighting requirements developed using IES RP22-11 and NFPA 502.

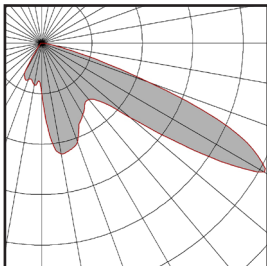

**CCB, ceiling mount counterbeam –** Recommended for divided tunnels with the majority of lumens directed against oncoming drivers to maximize roadway luminance while controlling disability glare. The distribution is similar to IES type III asymmetric distribution but is oriented toward the oncoming driver rather than perpendicular to the direction of travel.

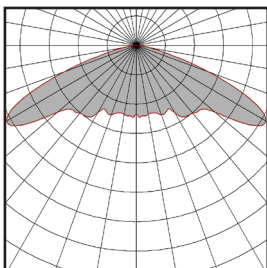

**CLN, ceiling mount long and narrow –** Used in undivided tunnels, equal lumens are directed with and against the traffic flow. Similar to IES type II asymmetric long and narrow distribution. Distribution is oriented with or against traffic flow so the length of the distribution is aligned with the tunnel roadway.

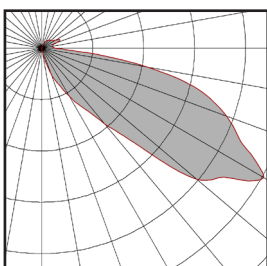

**WCR, wall mount crossbeam –** Employed in undivided tunnels, equal lumens are directed with and against traffic flow. Distribution is oriented perpendicular to the traffic flow.

## Corrosion Resistance

TunnelPass LED luminaires from Holophane incorporate several corrosive-resistant features to ensure performance and longevity:

- Borosilicate prismatic glass lens for permanence
- Low copper cast aluminum housings
- Stainless steel external hardware
- Stainless steel mounting plates
- Super durable paint over anodized pre-coat finish

Other performance attributes include a thermal management system, surge protection and control integration. TunnelPass LED luminaires offer a 9,000-hour salt fog rating, a UL Marine 40°C rating to withstand high pressure hose downs and a 3G vibration rating.

They comply with the requirements of NFPA and have undergone impact resistance testing to confirm they will withstand the impact of stones and other objects flung from the tires of passing vehicles.

Borosilicate Prismatic Glass Refractor



Heavy Duty Stainless Steel Latch or Bolted Door Assembly

Stainless Steel Mounting Plate Ships Attached

## MECHANICAL DESIGN



External Heat Sink provides excellent thermal transfer resulting in L70 values greater than 100,000 hours



Borosilicate Prismatic Glass refractor for durability, permanence, and glare control



Two Side Entry 3/4" NPT brass thru-wiring access plugs and one top entry 3/4" NPT brass access plug



Removable Door with heavy duty latch system

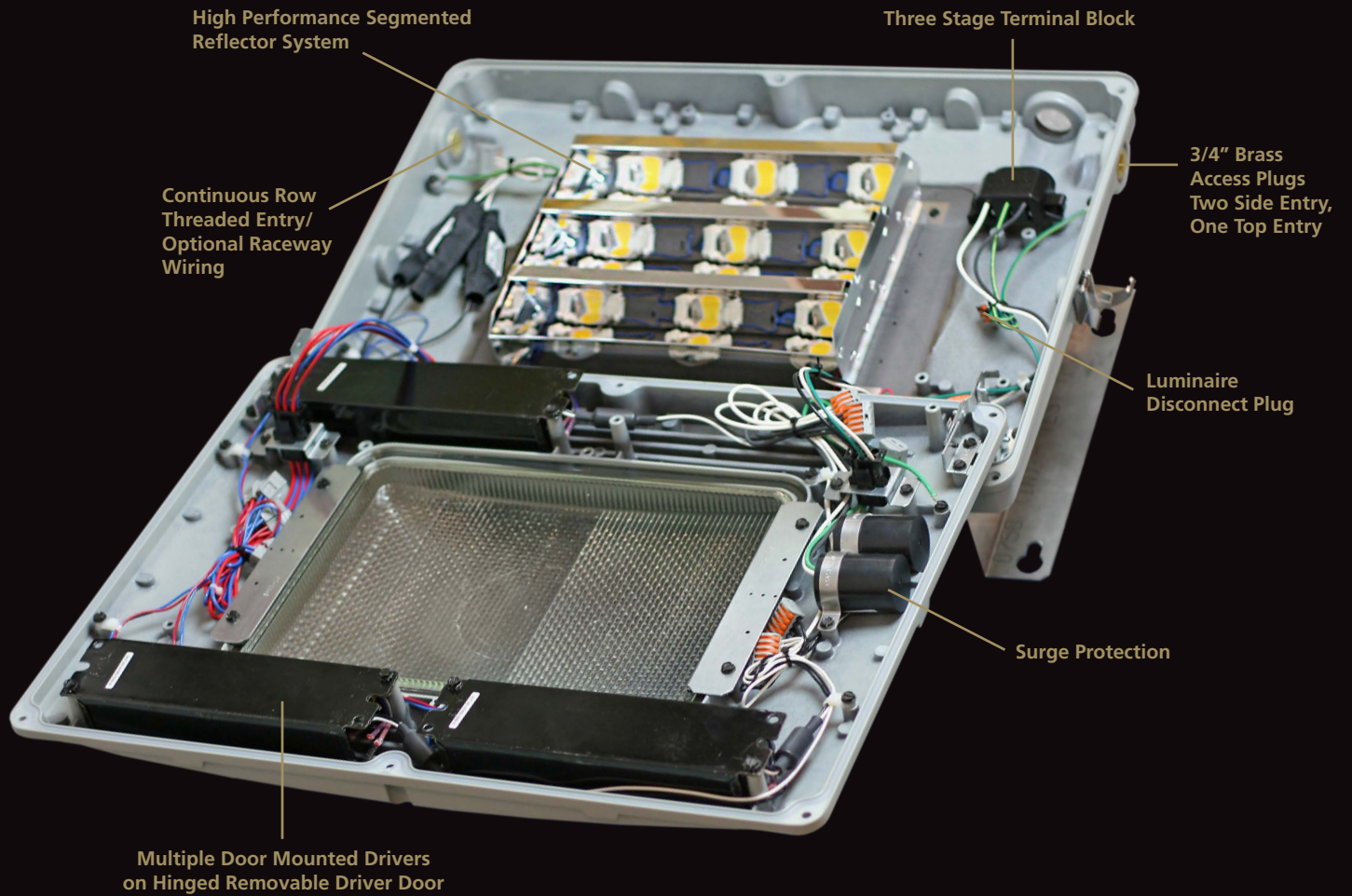

## LED OPTICAL DESIGN



Hinged Removable Driver Door mates to optical housing for easy access to terminal block, luminaire disconnect plug, and surge protection.

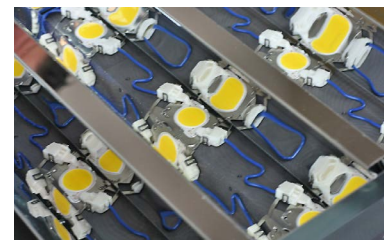

High Performance segmented reflector system with counterbeam, long and narrow, and crossbeam distributions.

# APPLICATION EFFICACY

Applications of new LED technology in the TunnelPass LED Luminaire make it suitable for retrofit replacement of 400 watt HPS fixtures while satisfying requirements of IES RP22-11. These requirements will be met for longer periods of time with less maintenance and energy consumption than the HPS system it replaces. To illustrate the benefits over time TunnelPass LED will be compared with a HPS lighting system which meets RP22-11 recommendations. The road luminance and energy use of the HPS system will then be compared with the TunnelPass LED fixtures.

The example tunnel is a 250-ft long urban tunnel with posted speed of 60 mph. There are three 12-ft wide asphalt traffic lanes between 8-ft shoulders. No cyclists are permitted. The exit is visible from one safe sight stopping distance before the entrance portal. Daylight penetration is poor. Reflectance of walls is 40%. The minimum recommended average roadway luminance is 160 candelas per sq meter. Uniformity ratios are recommended to not exceed 2.0 average to minimum and 3.5 maximum to minimum. The diffuse wall luminance is recommended to be at least 40% of the road luminance.

TUNNELPASS LED		
Luminaire	400 HPS Counterbeam	TNLED61ASCCB
Quantity	165	135
Maintained Luminance	160 Cd/Sq M	160 Cd/Sq M
Avg/Min	1.42	1.38
Max/Min	1.68	1.60
Wall Luminance	60%	48%
Avg/Min	1.06	1.05
Max/Min	1.12	1.10
Wattage	460	239
\$/kwhr	\$0.15	\$0.15
Hours	4380	4380
Annual Energy	\$49,866	\$21,198
<b>Energy Savings</b>		<b>\$28,668</b>
<b>% Energy Savings</b>		<b>57%</b>

## COMPARISON OF AVERAGE LUMINANCE OVER TIME

Over time, the light level decreases from the initial condition due to lumen depreciation, lamp burn outs, and dirt accumulating on the optics of the fixture. Accumulation of dirt on the fixture will be the same for either the HPS or the TunnelPass LED. In this example it is given that the installation will be cleaned annually when the lumen output due to dirt is 70% of its original value (LLD).

The mortality factor due to lamp burnouts differs between HPS and LED sources (LBO). This information is published by lamp manufacturers. LED lamp mortality is highly dependent upon the heat transfer characteristics of the luminaire. The TunnelPass LED has a L70 rating greater than 100,000 hours.

Lumen depreciation is also very different between the two sources. Similar to mortality factors, lamp manufacturers publish lumen depreciation curves for HPS lamps at 10% intervals of rated lamp life. In this case the life rating of the HPS lamp is 30,000 hours. The lumen depreciation for LED is estimated according to TM-21 data. The rate of lumen depreciation of the TunnelPass LED luminaire is much slower than the HPS. For example, when the HPS is at the end of its rated life the lumen depreciation (LLD) is 72% of the initial value. At this point in time the LED's lumen depreciation is 95% of its initial value.

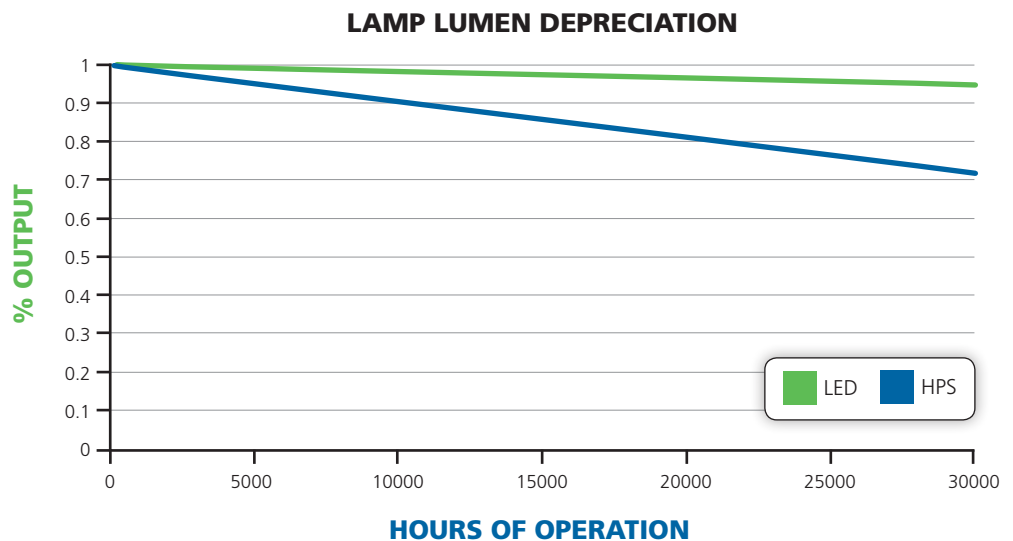

CONTINUED ON NEXT PAGE



CONTINUED FROM PREVIOUS PAGE

## COMPARISON OF AVERAGE LUMINANCE OVER TIME

The LLD, LBO and LDD are the major factors in determining the road luminance at any point in time. Multiplying the factors together results in a product that is referred to as the Light Loss Factor (LLF). The product of the initial road luminance and the LLF is the predicted road average luminance at that point in time. The IES recommended average luminance is 160 cd per sq m. The HPS source reaches this value at 16,800 hours of operation, or at 3.83 years. At this time the installation needs relamped. Maintenance will require the cost of lane closures, labor and cost to replace failed lamps and ballasts to restore the system back to designed levels.

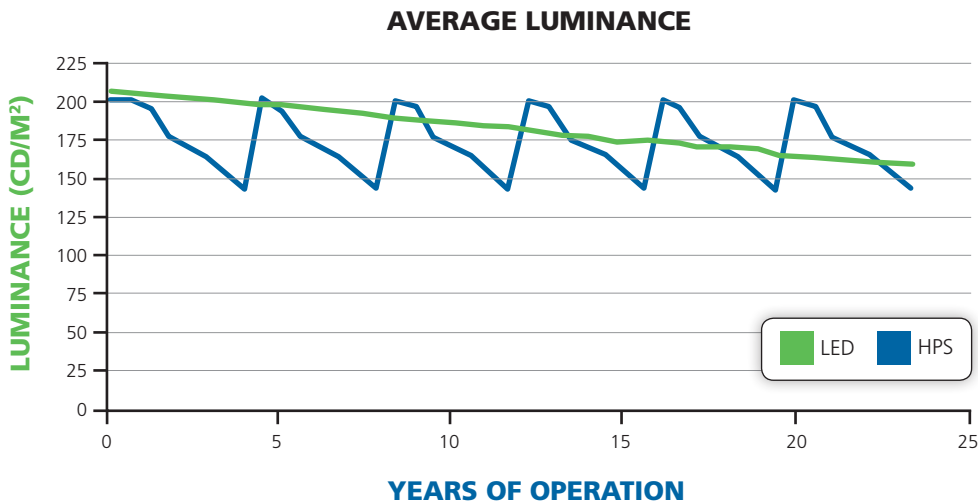
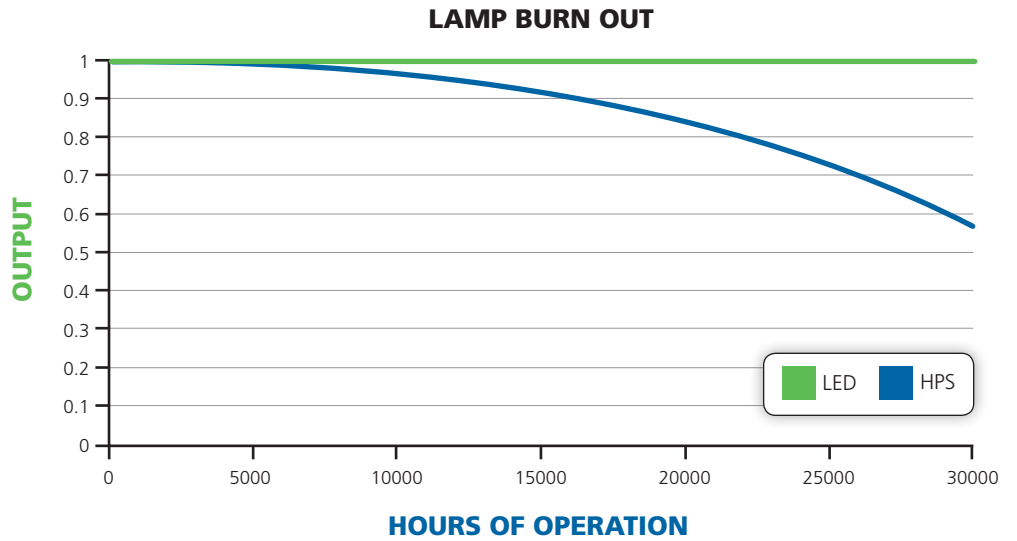

After more than 23 years of operation, the TunnelPass LED has a maintained average luminance greater than the required 160cd/Sq m, which equates to 23 years of maintenance free operation. At this time, the HPS system will have been relamped five times and would be nearing a sixth lamp change.

## ADDITIONAL SAVINGS AND ADVANTAGES

Public safety is improved with the TunnelPass LED luminaire while reducing operational costs. A more reliable lighting system will provide the required luminance to allow driver's vision to adapt to light levels inside the tunnel. This will keep the traffic moving in a safe manner. Longer intervals between maintenance procedures will also produce operational cost savings resulting from the lighting system needing less maintenance to keep IES recommended average road luminance levels.

The largest savings will come as a result of the reduction in lane closures. Vehicular traffic through a high volume tunnel can exceed 150,000 vehicles per day. The process to implement the lane closure is costly, requires political intervention to execute, and the result is a negative impact on both the state and local commerce.

**Minimize Lane Closures**  
**20+ Year Service Life**  
**50% Energy Savings**

**PERFORMANCE SPECIFICATIONS**

**General Construction**

Low copper content diecast aluminum A360 alloy electrical and optical housing. Diecast aluminum housing has integral heat sink fins to optimize thermal management through conductive and convective cooling. Stainless steel bolted or latched door closure options disengages top electrical cover for easy access to LED drivers, surge devices, luminaire disconnect plug and terminal block. Vibration rated to 3G applications per ANSI C136.31-2001. IP 66 rated luminaire per IEC 60529. Superdurable TGIC thermoset powder coat finish over anodized aluminum pre-finish. Finish shall pass 9,000 hour salt fog test per ASTM B117 and D1654. Suitable for Continuous Row Mounting and optionally as a Raceway. 3/4-14 NPT top entry and two 3/4-14 NPT side entries. 316 grade stainless steel mounting brackets for ceiling, wall, or optional box mount.

**Electrical**

Quick disconnect connectors for ease of installation and maintenance. Class 1 drivers rated for 100,000 hours life. Surge protection meets 10KV/5KA per ANSI/IEEE C62.41. Driver power factor is 90% minimum. Driver meets maximum total harmonic distortion (THD) of 20%.

**Optical**

Multi die LED chip on board (COB) technology, with color temperature options of 4000K and 5000K and a CRI of 70 minimum. Segmented internal reflectors are designed for superior optical control in Counterbeam, Crossbeam, and Long and Narrow distributions. Optical enclosure shall be of borosilicate prismatic glass.

**Testing Compliance**

Luminaire conforms to following standards:  
 IEC 61000 - Electromagnetic Compatibility Test (EMC)  
 FCC Title 47 CFR Part 18 - Federal Communications Commission  
 ANSI/IEEE C62.41.2-2002 Surge Protection  
 IEEE 519 - Harmonic control in Electrical Power systems. ANSI C82.77:2002 - Harmonic distortion.  
 ANSI C136.31:2001 - Luminaire vibration.  
 ASTM B 117:2003 - Salt spray test.  
 IEC 60529 - Degrees of protection provided by enclosure (IP).

**Regulatory**

The luminaire is safety listed to UL/CUL 1598, 40°C, wet location. 30°C when used as a Raceway. Key components including surge protection device, LED drivers, and COB arrays are ROHS compliant.

**CONTINUOUS ROW (STANDARD)**

The TunnelPass LED comes standard for continuous row mounting. By definition, this occurs when individual luminaires connected together by a recognized wiring method, shall be permitted to contain the conductors of a 2 wire branch circuit or one multi-wire branch, there by supplying the connected luminaires. One additional 2-wire branch circuit separately supplying one or more of the connected luminaires shall also be permitted. The luminaire would have a 40°C ambient listing.

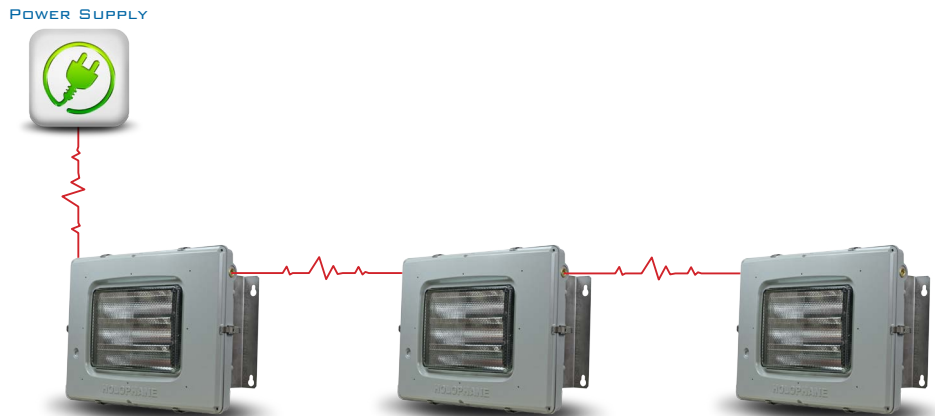

**THROUGH WIRING RACEWAY (TW-OPTION)**

The TW is for the use of luminaires as raceways. By definition, luminaires intended to serve as a raceway for conductors of a circuit other than the conductors of the branch circuit supplying the luminaire. The TW is a fixture option and allows max 10-#10 conductors, suitable for 90°C permitted in box. The luminaire would have a 30°C ambient listing with the TW option.

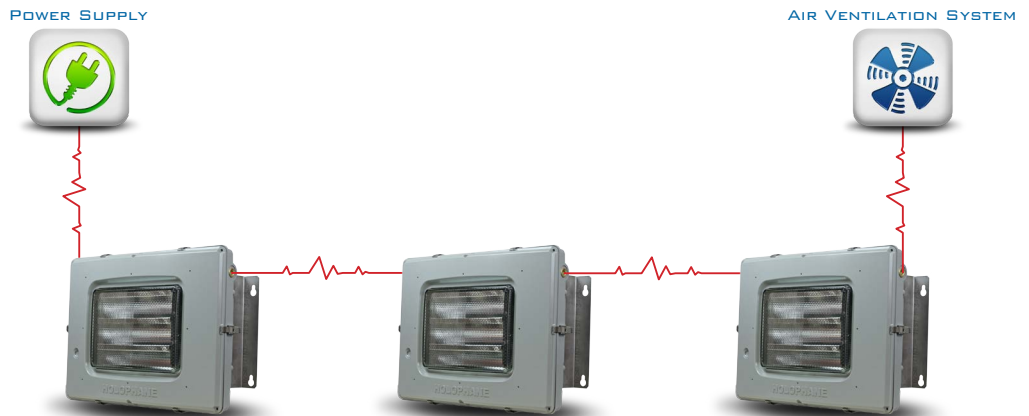

# ORDERING INFORMATION

PREFERRED SELECTIONS:

Most Frequently Ordered Catalog Numbers

TNLED	9	5K	1	AH	CCB	DGRA	S
1	2	3	4	5	6	7	8
LUMINAIRE	LED MODULES	COLOR TEMP	DRIVE CURRENT	VOLTAGE	OPTICS	COLOR	DOOR CLOSURE
TNLED	3 6 9	3K 4K 5K	1 7	AS AH	CCB CLN WCR	A DBKA DBZA DGRA DWHA	L S

CATALOG NUMBERS FOR ENTIRE PRODUCT OFFERING

(Pricing and lead times may be affected)



<b>STEP 1: LUMINAIRE</b> <b>TNLED</b> TunnelPass LED™	<b>STEP 4: DRIVE CURRENT</b> <b>1</b> 1050mA driver <b>7<sup>1</sup></b> 700mA driver	<b>STEP 6: OPTICS</b> <b>CCB</b> Ceiling mount counterbeam <b>CLN</b> Ceiling mount long & narrow <b>WCR</b> Wall mount crossbeam	<b>STEP 8: DOOR CLOSURE</b> <b>L</b> Latched <b>S</b> Screws
<b>STEP 2: LED MODULES</b> <b>3</b> 3 Modules <b>6</b> 6 Modules <b>9</b> 9 Modules	<b>STEP 5: VOLTAGE</b> <b>AS</b> Auto-sensing voltage (120-277V) <b>AH</b> Auto-sensing voltage (347-480V)	<b>STEP 7: COLOR</b> <b>A<sup>2</sup></b> As specified <b>DBKA</b> Black <b>DBZA</b> Bronze <b>DGRA</b> Gray <b>DWHA</b> White	<b>STEP 9: OPTIONS</b> <b>BM</b> Box mount <b>DM</b> 0-10V dimming control <b>F1</b> Single fusible <b>F2</b> Double fusible <b>TW</b> Through wiring raceway
<b>STEP 3: COLOR TEMP</b> <b>3K</b> 3,000 CCT+/-250K <b>4K</b> 4,000 CCT+/-250K <b>5K</b> 5,000 CCT+/-250K		<p>*Colors are just a representation. Custom colors are available upon request</p>	<p>1 Not available with 9 modules                  2 Handled as custom</p>

DIMENSIONAL DETAILS

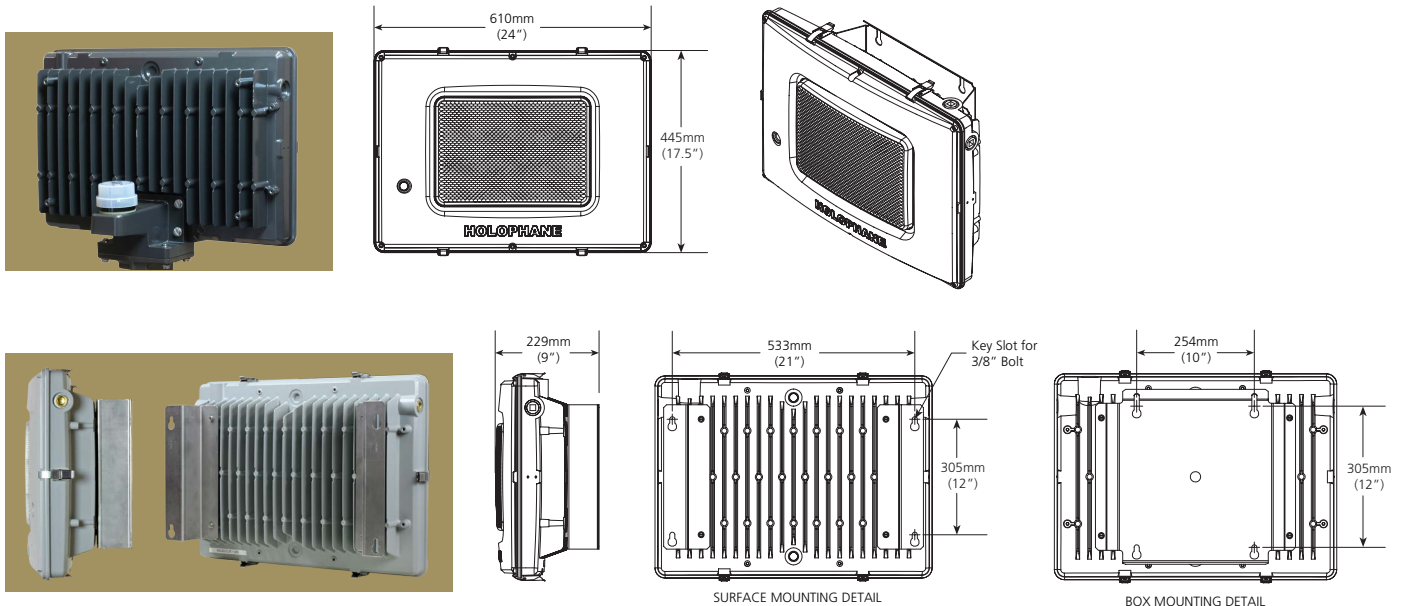

**TunnelPass LED**  
 Maximum weight: 55lbs (24.9kg)  
 Maximum E.P.A.: 3.5 sq. ft.



Warranty Five-year limited warranty. Full warranty terms located at [www.acuitybrands.com/CustomerResources/Terms\\_and\\_conditions.aspx](http://www.acuitybrands.com/CustomerResources/Terms_and_conditions.aspx)  
Product specifications may change without notice. Please contact your sales representative for the latest product information.

Contact your local Holophane factory sales representative for application assistance, and computer-aided design and cost studies.  
For information on other Holophane products and systems, call the Inside Sales Service Department at 866-759-1577.  
In Canada call 905-886-8967 or fax 905-886-7973.