



# COMBI OVEN-STEAMER Options & Accessories

Project \_\_\_\_\_  
 Item \_\_\_\_\_  
 Quantity \_\_\_\_\_  
 FCSI Section \_\_\_\_\_  
 Approval \_\_\_\_\_  
 Date \_\_\_\_\_

COMBI OVEN-STEAMER

## Stacking Stand for one Convotherm 6.20 Combi and one Convection Oven

### Convotherm Standard Features:

- Stand frame constructed of 1 1/2" thick wall, square tubing
- Solid top for directing heat away from Combi
- Crossbar supported on three sides
- Corner gussets for additional rigidity
- 16 gauge stainless steel table top
- Four, one (1) inch high locator pins for mounting 6.20 combi on stand
- Stand restraining device (CBST62042CA only)
- Four level adjustable flanged feet (CBST62042 only)
- Four heavy duty 3" diameter swivel casters, two with brakes (CBST62042CA only)
- Service friendly and easy to clean
- UL Sanitation approved, according to NSF2 standards

### Notes:

- The stands are designed to accommodate full or half size gas or electric Convection Ovens
- The stands are built to support all Convotherm 6.20 Combi models
- The Convection Oven must always be installed on the bottom

- MODEL:**  CBST62042 (PN 112433) (with legs)  
 CBST62042CA (PN 112421) (with casters)



### Short Form Specifications

Shall be Convotherm Model: CBST62042\_\_\_ Stacking Stand for one Convotherm 6.20 Combi and one full or half size Convection Oven. Stand frame constructed of 1 1/2" thick wall, square tubing. Crossbar supported on three sides. 16 gauge stainless steel table top. Four, one (1) inch high locator pins for mounting 6.20 combi on stand. Stand restraining device (for CBST62042CA only). Four level adjustable flanged feet (CBST62042) or four heavy duty 3" diameter swivel casters, two with brakes (CBST62042CA).



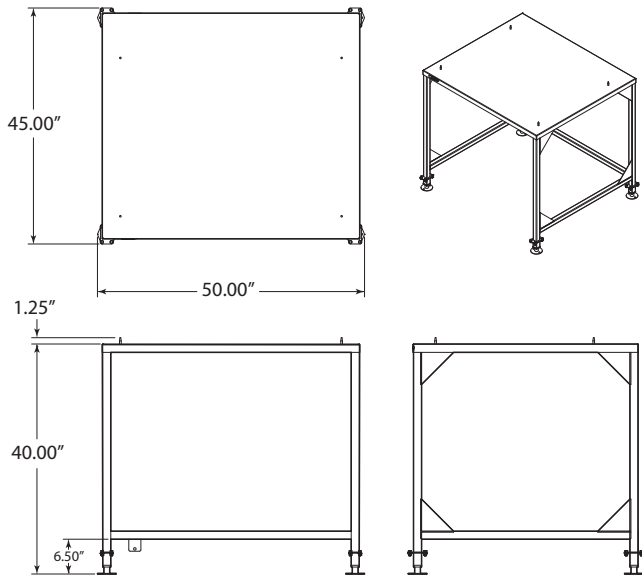

**CST62042 (with feet)**

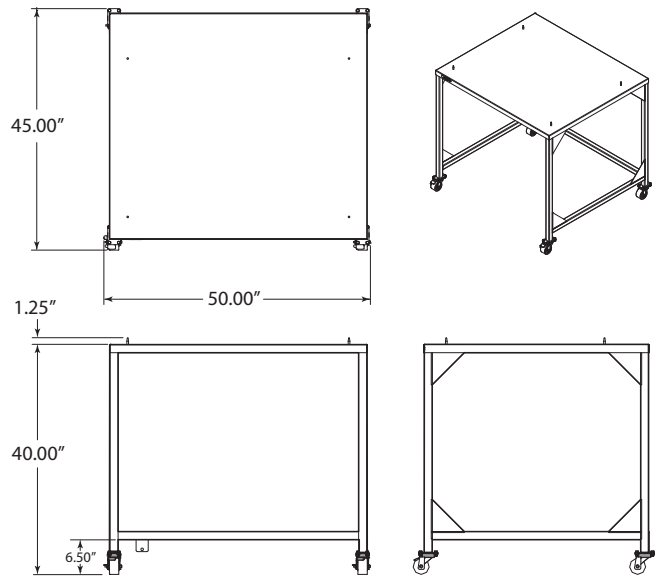

**CST62042CA (with casters)**

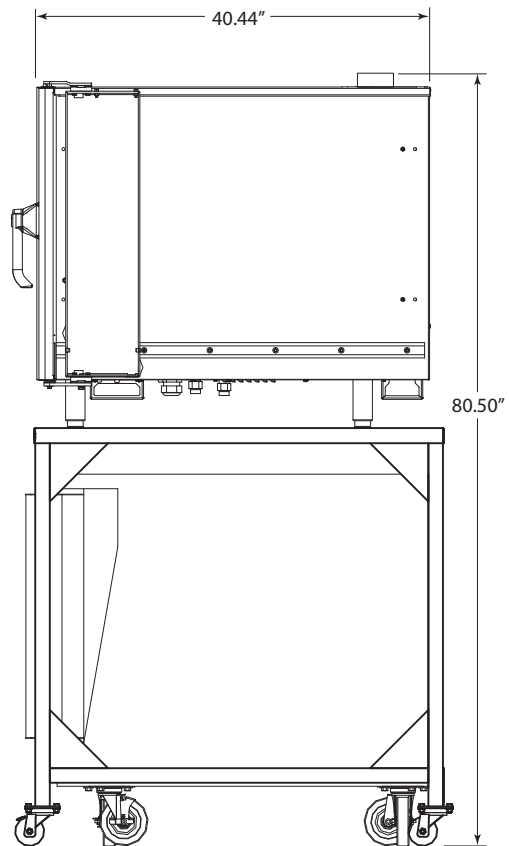
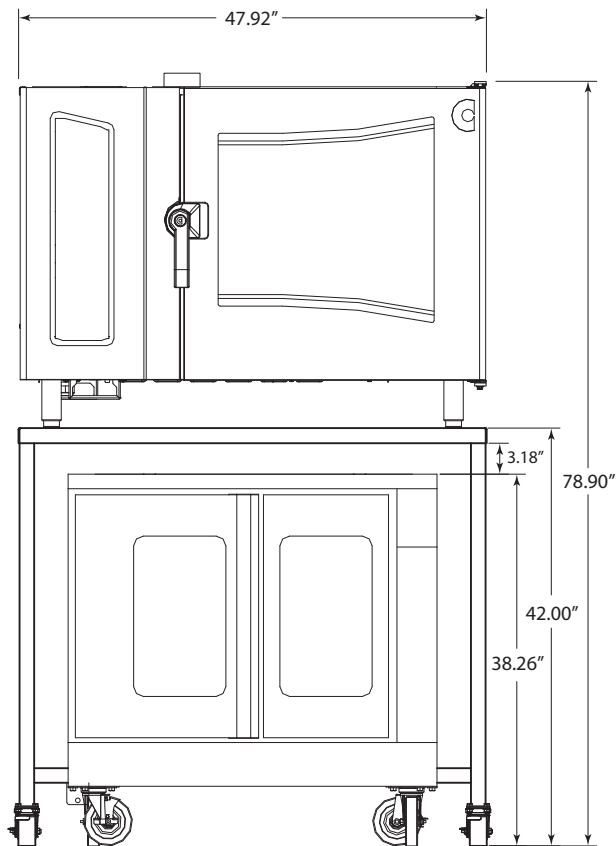

**The Convection Oven manufacturer and installers are responsible for proper venting and if needed installing a flue diverter for the Convection Oven (not supplied by Convotherm).**

**NOTES:**

Convotherm reserves right of design improvement or modification, as warranted.  
 Many regional, state and local codes exist and it is the responsibility of the owner and installer to comply with the codes.  
 Convotherm equipment is built to comply with applicable standards for manufacturers.