

PSS12000

PARTS LIST & WIRING DIAGRAM

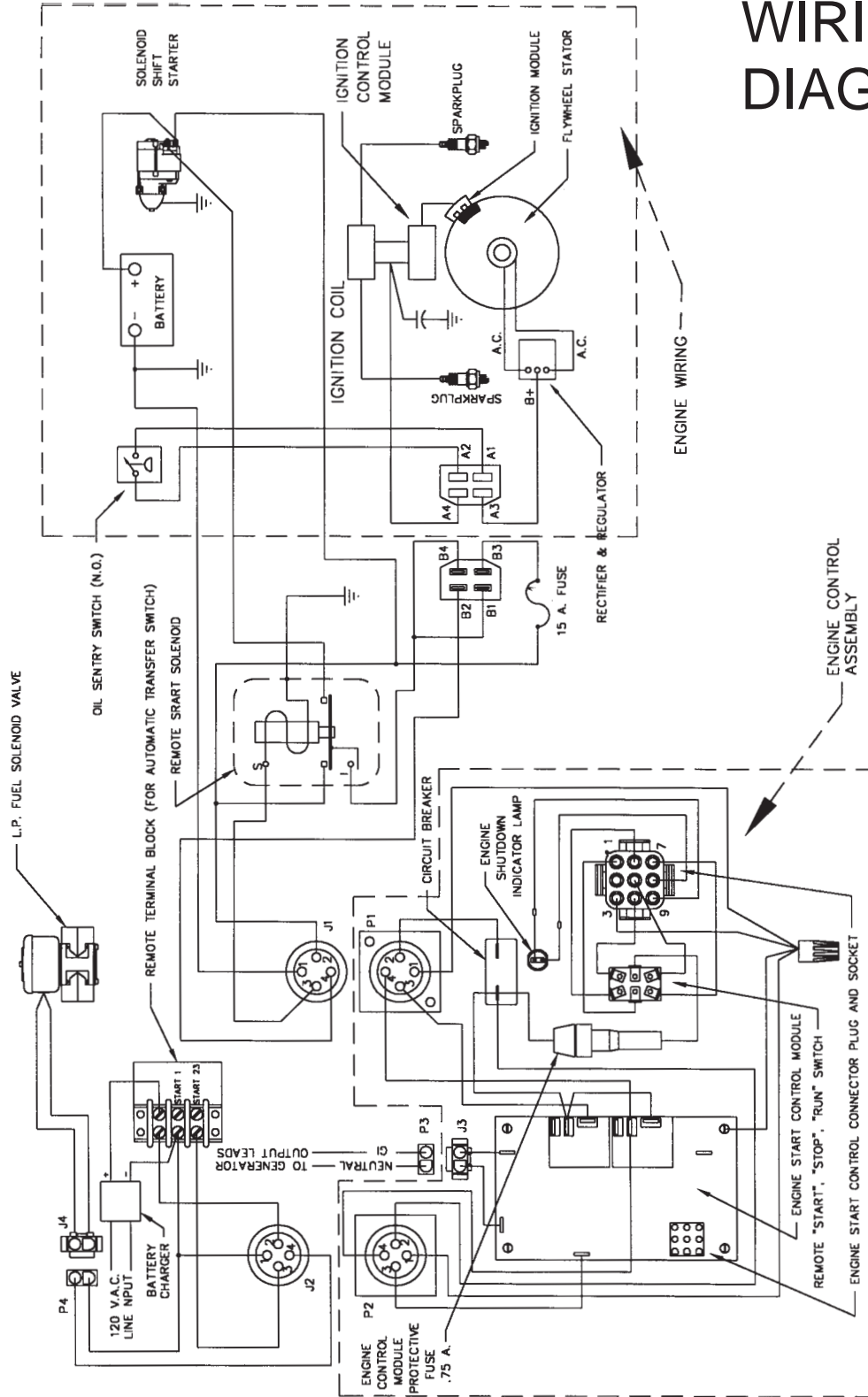

HOUSING AND INSULATION

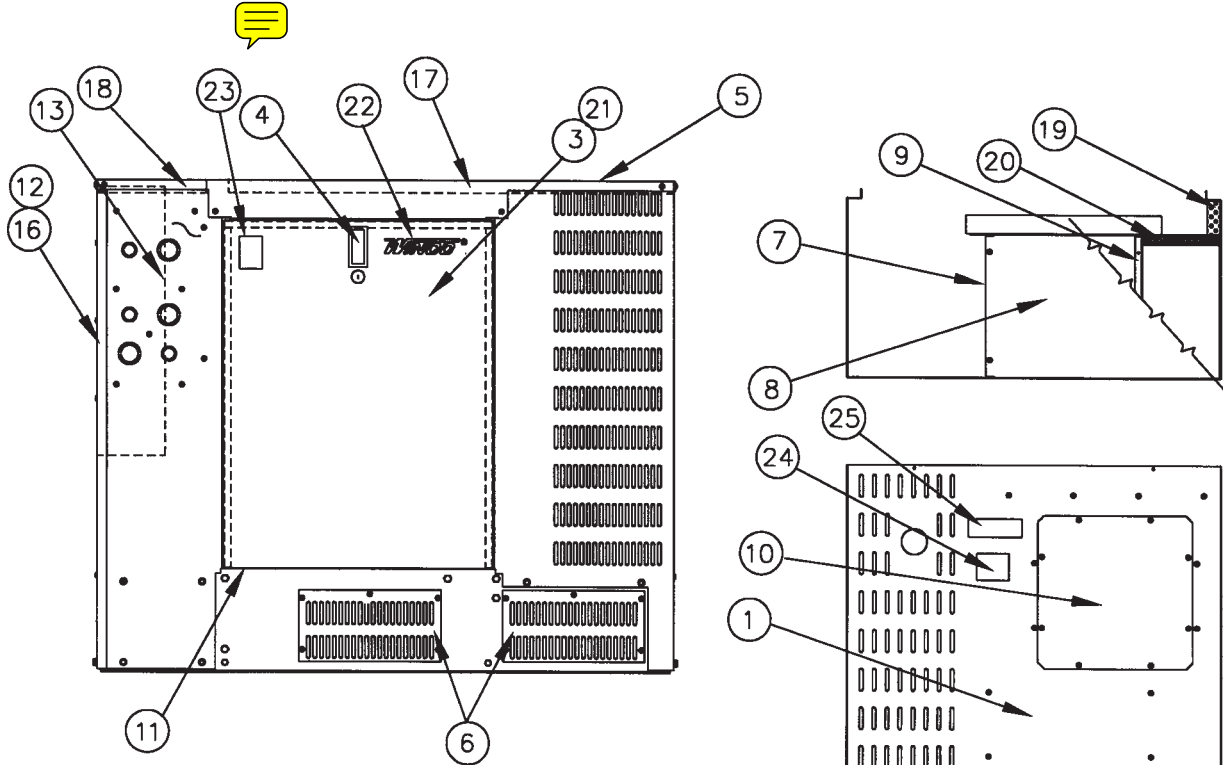

REF	DESCRIPTION	QTY	PART NBR
1	Housing, Front & Side	1	64736-000
2	Engine Air Duct Adapter	1	64739-000
3	Door	2	64745-001
4	Door Latch	2	95229-004
5	Roof	1	64726-000
6	Base Access Cover Plate	2	64738-000
7	Air Duct, Right & Bottom	1	64740-000
8	Air Duct, Top	1	64741-000
9	Air Duct Baffle	1	64742-000
10	Cover Plate	1	64737-000
11	Foam Strip 1/8 X 1/2	16'	62912-000
12	Rear Cover Panel	1	64725-000
13	Baffle	1	64738-001
14	Adhesive Backed Foam	1	92421-000
15	Grommet	1	23917-000
16	Acoustical Foam, Cover Panel	1	64730-407
17	Acoustical Foam, Roof	1	64730-409
18	Acoustical Foam, Roof	1	64730-408
19	Acoustical Foam, Housing	1	64730-406
20	Acoustical Foam, Housing	1	64730-410
21	Acoustical Foam, Door	1	64730-405
22	Decal, WINCO	2	53113-001
23	Decal, Auto Start	2	97813-001
24	Decal, Danger	1	15209-000
25	Decal, Hot Surface	2	63941-001

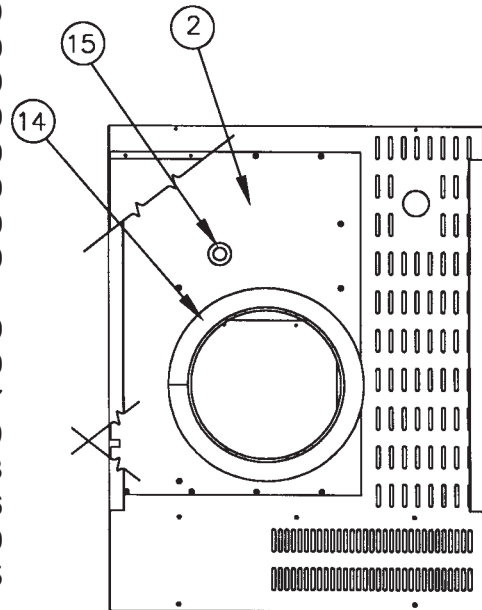

FUEL SYSTEM

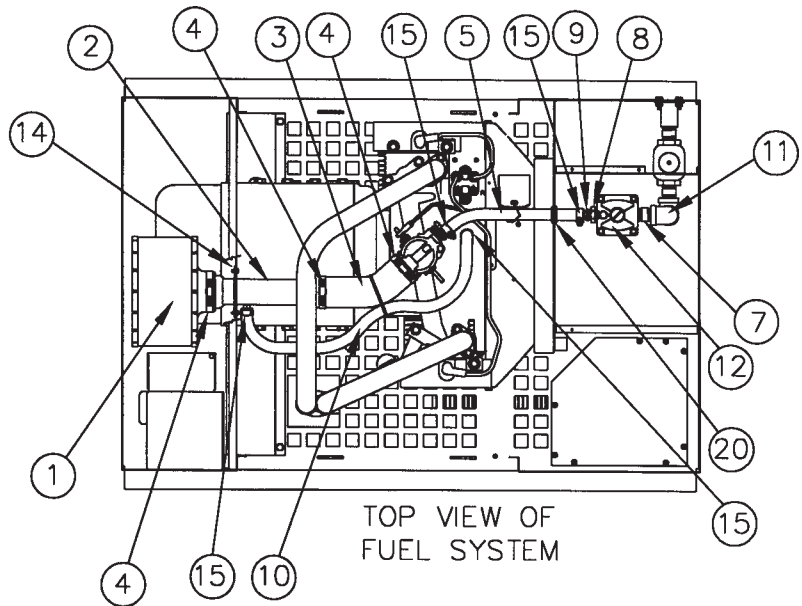

REF	DESCRIPTION	QTY	PART NBR
1	Air Cleaner	1	64731-000
2	Air Cleaner Mtg Tube Assy	1	64735-000
3	Carburetor Air Hose	1	64758-000
4	Hose Clamp	3	81018-002
5	½" I.D. Hose	13"	23048-000
6	Fuel Inlet Brkt Assy	1	55931-000
7	Pipe Nipple ¾ X 2"	3	54074-003
8	Reducing Bushing 3/8" to 3/4"	1	63788-000
9	Hose Fitting ½"	1	92388-002
10	½" I.D. Hose	28"	23048-000
11	¾" Pipe Elbow	2	50244-000
12	Fuel Regulator	1	50248-000
13	¾" X 15" Black Iron Pipe	1	54074-004
14	#10 X 3/8 Self Tapping Screw	8	21698-000
15	Hose Clamp	4	81018-005
16	Fuel Solenoid	1	42942-000
17	¼" -20 X ¾" Hex Head Bolt	2	466-000
18	¼" Lockwasher	2	479-000
19	¼"-20 Hex Nut	2	638-000
20	Grommet	1	62486-000
21	Carburetor	1	64732-000
22	Ball Joint	2	63650-001
23	#10 Split Lockwasher	2	484-000
24	#10-32 Hex Nut	2	6372-000
25	Governor Linkage	1	63334-001

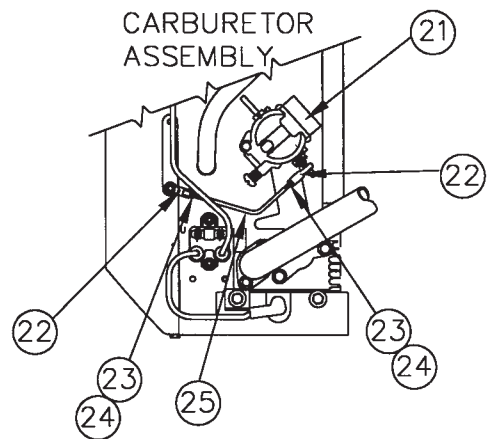
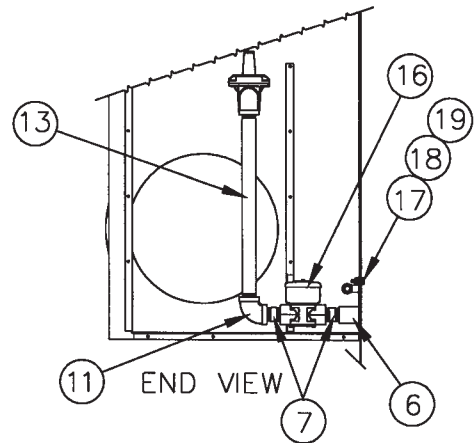

ENGINE GENERATOR BASE ASSEMBLY

REF	DESCRIPTION	QTY	PART NBR
1	Mounting Base	1	64712-000
2	Support Bracket	1	64710-000
3	Generator Support Bracket	1	64707-000
4	Support Bracket	1	64711-000
5	Shock Mount	4	98807-000
6	5/16-18 X 3/4" HH Bolt	28	467-000
7	5/16 Split Lockwasher	28	480-000
8	5/16-18 Hex Nut	28	458-000
9	Battery Tray	1	16026-000
10	#10-24 X 5/8" Threaded Stud	4	95568-000
11	Bottom Pan, Base	1	64713-000
12	1/4-20 Retainer Nut	8	92495-000
13	1/4 Split Lockwasher	8	479-000
14	1/4-20 X 3/4" HH Bolt	4	466-000
15	#10 Lockwasher	4	484-000
16	#10-24 Hex Nut	4	456-000
17	Exhaust Pipe Support Brkt	1	15810-001
18	3/8-16 X 1.5" HH Bolt	2	91658-003
19	Solenoid Mounting Brkt	1	64744-001
20	Generator Mounting Brkt	1	98355-001
21	Onan P224 Engine	REF	64765-000
22	Generator Assembly	REF	64754-000
23	3/8-16 X 2.5" HH Bolt	2	91658-007
24	3/8-16 X 3.5" HH Bolt	2	3288-000
25	Flat Washer, .078 Thick	4	8472-000
26	#10 GA Safety Washer	4	98806-000
27	3/8-16 Hex Nut	6	92914-000
28	3/8" Split Lockwasher	6	481-000
29	1/2-13 X 1.5 HH Bolt	1	57580-000
30	1/2" Split Lockwasher	1	636-000

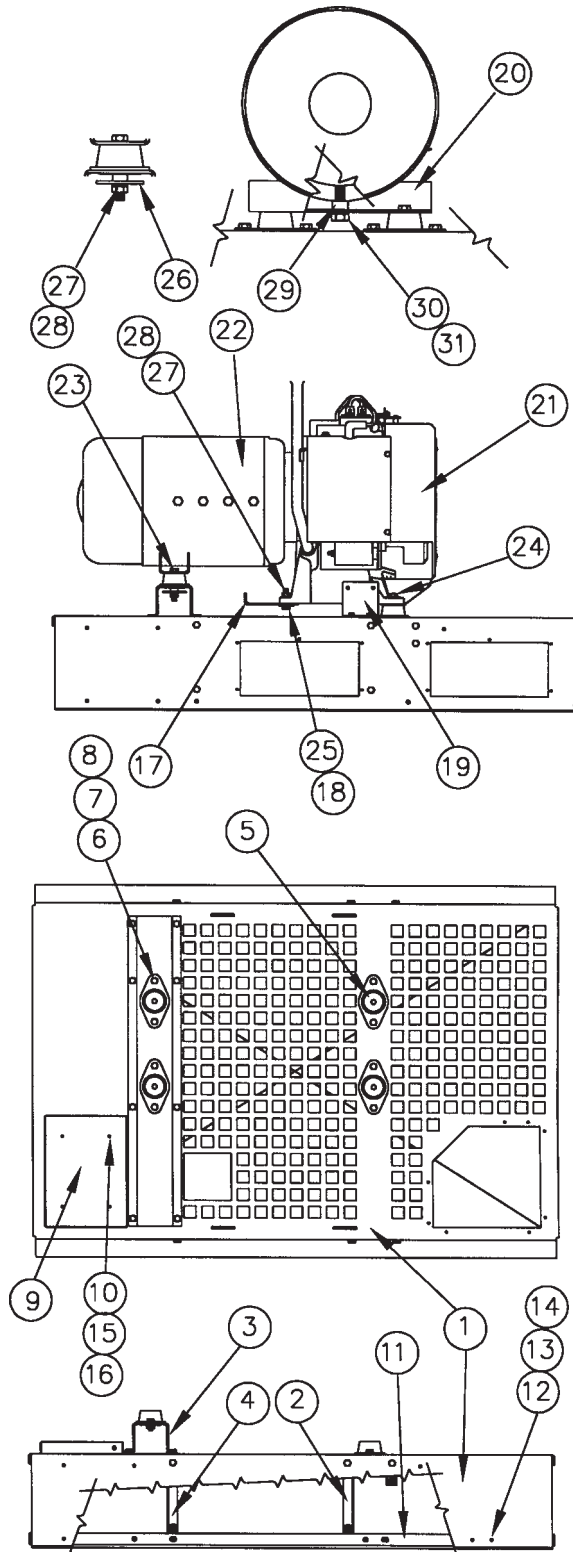

EXHAUST SYSTEM

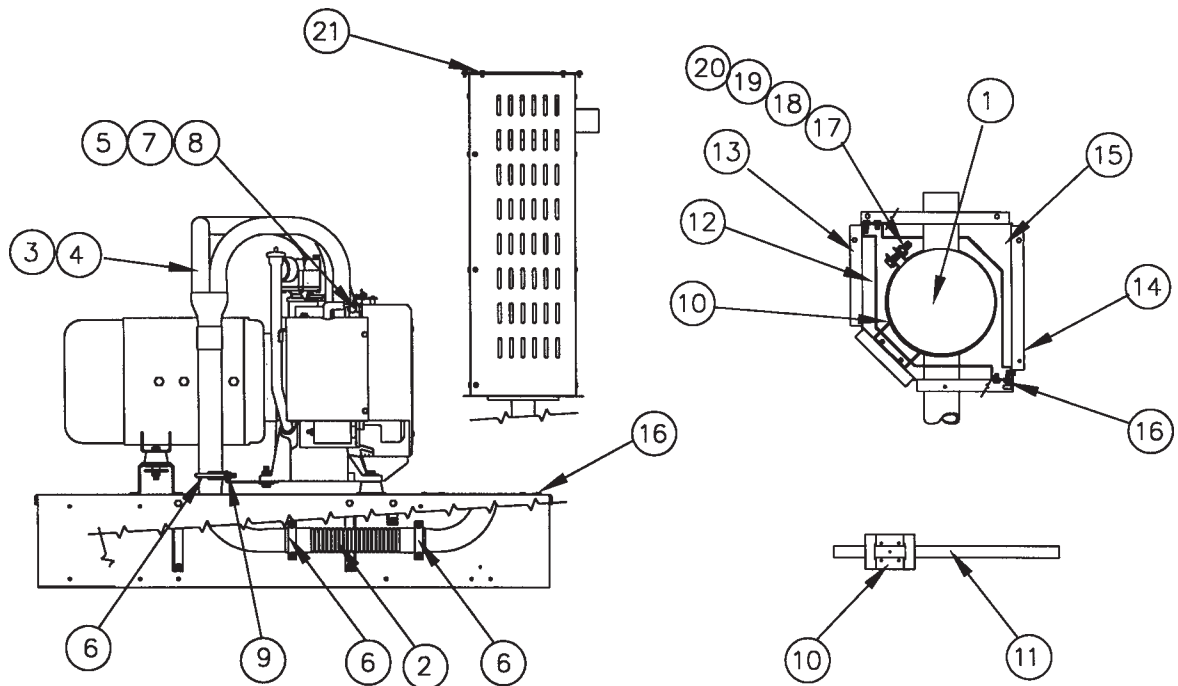

REF	DESCRIPTION	QTY	PART NBR
1	Muffler	1	64748-000
2	Flexible Exhaust	1	64743-001
3	Exhaust Header (Wrapped)	1	64747-001
4	High Temperature Silica Tape	40'	99518-000
5	Exhaust Gasket	2	64765-001
6	Exhaust Clamp 2"	3	93489-003
7	5/16 Serrated Belleville Washer	4	99544-000
8	5/16-18 X 3/4" Torx Socket Head Bolt	4	96024-003
9	5/16 Flat Washer	2	526-000
10	Muffler Mounting Bracket	2	64718-000
11	Muffler Mounting Strap	2	64719-000
12	Outer Rear Muffler Shield	1	64714-000
13	Rear Inner Muffler Shield	1	64715-000
14	Front Outer Muffler Shield	1	64716-000
15	Front Inner Muffler Shield	1	64717-000
16	#10 X 3/8" Sheet Metal Screw	45	21698-000
17	5/16-18 X 1.5 Hex Head Bolt	2	468-000
18	5/16" Flat Washer	4	526-000
19	5/16" Split Lockwasher	2	480-000
20	5/16-18 Hex Nut	2	458-000
21	Muffler Shield Cover	1	64720-000

ELECTRIC PANEL AND CONTROLS

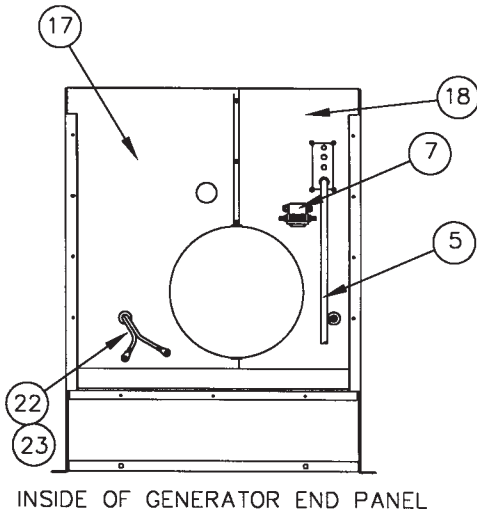
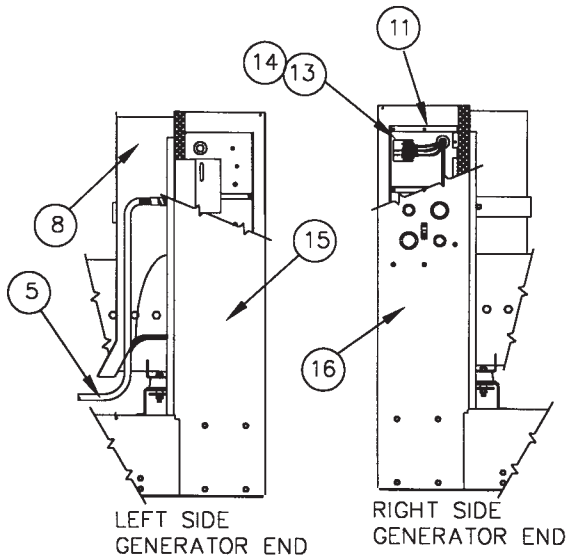
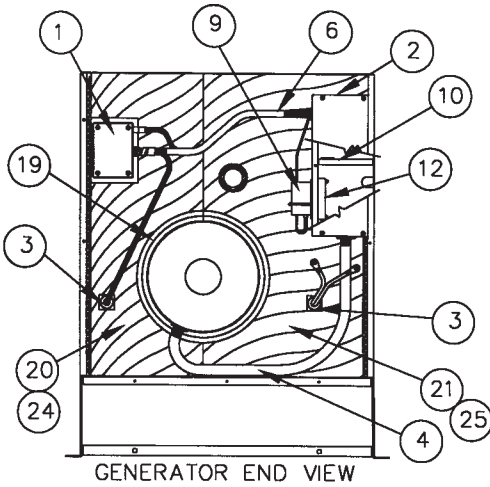

REF	DESCRIPTION	QTY	PART NBR
1	Engine Control Assembly	1	15764-403
2	Electrical Box Cover	1	64729-000
3	Grommet	2	23917-000
4	Power Wiring Harness	1	64757-002
5	Engine Wiring Harness	1	64575-001
6	Control Wiring Harness	1	64757-000
7	Remote Start Solenoid	1	80980-000
8	Heat Deflector	1	64772-000
9	Battery Tender	1	16287-000
10	Divider, Electrical Box	1	64728-000
11	Electrical Box	1	64727-001
12	Voltage Regulator	1	98884-002
13	Marker, Terminal Block	1	64599-001
14	Terminal Block	1	64598-000
15	Left Rear Housing Panel	1	64723-000
16	Right Rear Housing Panel	1	64724-000
17	Right Side Housing Divider	1	64722-000
18	Left Side Housing Divider	1	64721-000
19	Air Seal 40"	1	15287-008
20	Left Side Acoustical Panel	1	64730-402
21	Right Side Acoustical Panel	1	64730-403
22	Positive Battery Cable	1	22097-000
23	Negative Battery Cable	1	22097-005
24	Acoustical Foam	1	64730-401
25	Acoustical Foam	1	64730-404



GENERATOR ASSEMBLY

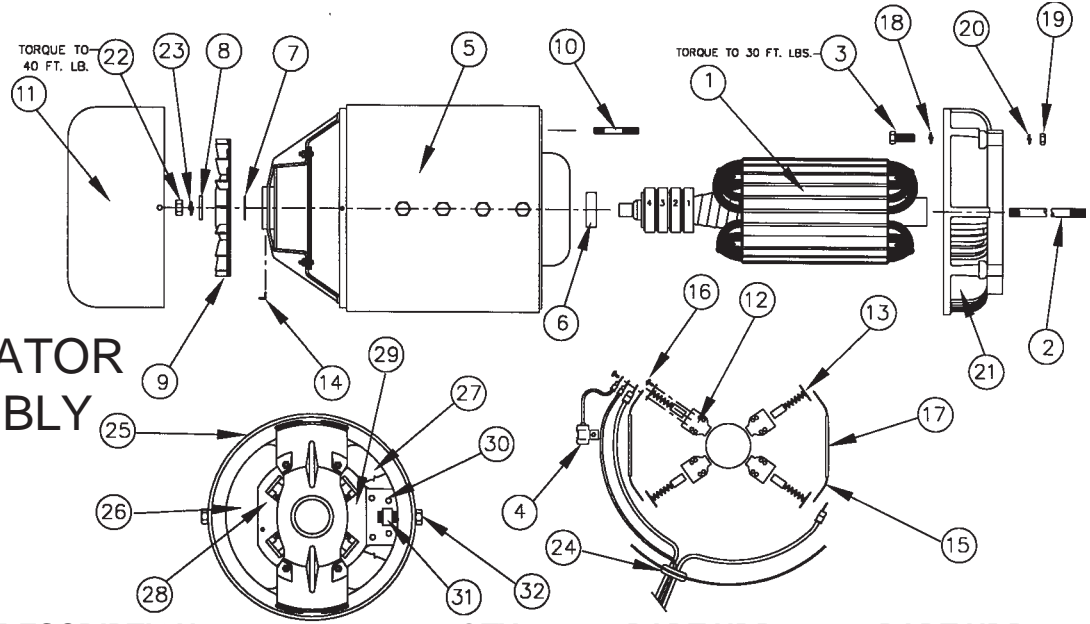

REF	DESCRIPTION	QTY	PART NBR	PART NBR
			PSS12000 & -17	PSS12000-4
1	Armature	1	98472-000	98472-002
2	Armature Bolt	1	98124-001	98124-001
3	3/8-16 X 2.0" Hex Head Bolt	4	91658-005	91658-005
4	Capacitor	3	41221-000	41221-000
5	Field Shell and Coil Assembly	1	64759-000	64579-000
6	Bearing	1	59062-000	59062-000
7	Flat Washer (.048" Thick)	1	97627-001	97627-001
8	Flat Washer (.078" Thick)	1	21867-000	21867-000
9	Fan Assembly	1	23404-000	23404-000
10	5/16-18 X 2.38" Stud	4	23451-000	23451-000
11	End Cover	1	97472-002	97472-002
12	Brush Holder	16	23500-002	23500-002
13	AC Brush Assembly	16	24981-000	24981-000
14	Anti-Rotation Pin	1	59063-000	59063-000
15	Copper Strap	8	41387-008	41387-008
16	#8-32 X 5/16 Machine Screw	32	40746-000	40746-000
17	Insulation Tube	7	46024-003	46024-003
18	3/8" Split Lockwasher	4	481-000	481-000
19	5/16-18 Hex Nut	4	458-000	458-000
20	5/16" Split Lockwasher	4	480-000	480-000
21	End Bracket, Engine	1	98470-000	98470-000
22	7/16-14 Hex Nut	1	81034-000	81034-000
23	7/16" Split Lockwasher	1	90570-000	90570-000
24	Grommet	1	62486-000	62486-000
25	Field Shell & Bracket	1	97288-000	97288-000
26	Field Coil, Left Side	1	63938-000	63938-000
27	Field Coil, Right Side	1	63938-001	63938-001
28	Brush Rack Assembly, Left	1	64760-000	64760-000
29	Brush Rack Assembly, Right	1	64760-001	64760-001
30	Pole Shoe Assembly	2	43473-000	43473-000
31	Pole Shoe Retainer	2	63937-000	63937-000
32	7/16-20 X 1.75" Hex Head Bolt	8	43781-000	43781-000

ALL BRUSH HOLDER DETAILS ARE DRAWN LOOKING TOWARD MOUNTING PLATE, ON WHICH THEY ARE FASTENED.

LEAD WIRES SHOWN EXITING FROM END COVER ARE PART OF HARNESS ASSEMBLY, SEE DRAWING B-64756-002

LEADS G3 FROM SLIP RING #2 HAS THE WILD LEG VOLTAGE.

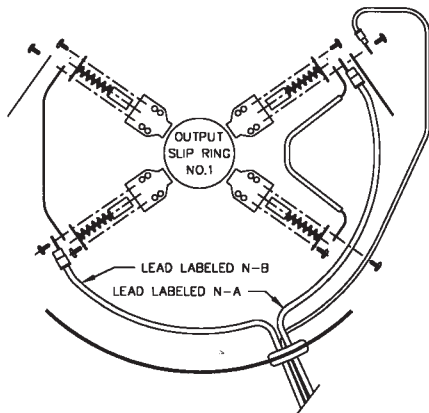
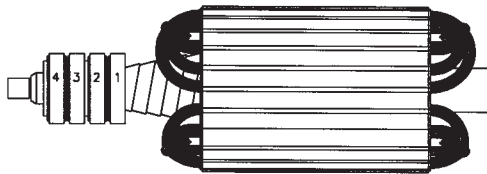

LEAD LABELED N UNDER GROUND SCREW IN ELECTRICAL OUTPUT BOX

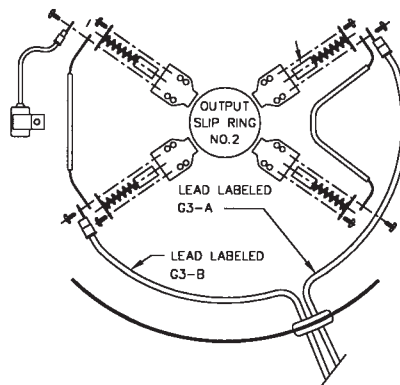

LEAD LABELED G-3 (WILD LEG) FROM OUTPUT ELECTRICAL BOX USED FOR THREE PHASE ONLY

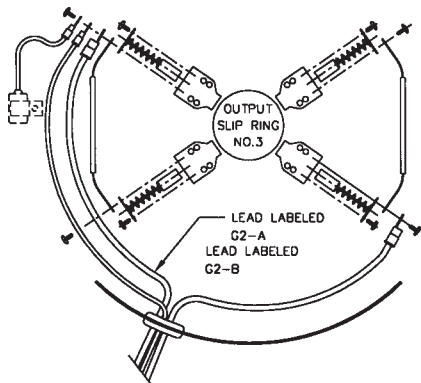

LEAD LABELED AC-2 FROM OUTPUT ELECTRICAL BOX

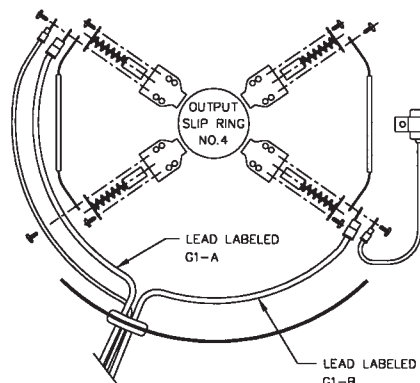

LEAD LABELED AC-1 FROM OUTPUT ELECTRICAL BOX

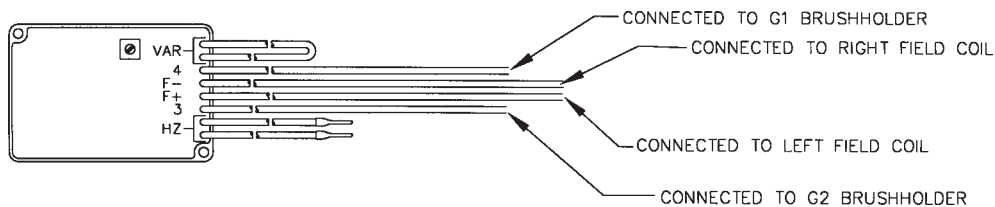

WINGO INC
A Division of **DTI** Dyna Technology Inc

225 S. Cordova Ave
Le Center MN 56057
507-357-6831